

4

AD-A208 260

TECHNICAL REPORT BRL-TR-3001

**BRL**

A LIBRARY OF DIGITIZED FLIGHTPATHS

JOSEPH K. WALD

JUNE 1989

DTIC  
ELECTE  
MAY 22 1989  
S E D

APPROVED FOR PUBLIC RELEASE; DISTRIBUTION UNLIMITED.

U.S. ARMY LABORATORY COMMAND

BALLISTIC RESEARCH LABORATORY  
ABERDEEN PROVING GROUND, MARYLAND

80 047

UNCLASSIFIED

SECURITY CLASSIFICATION OF THIS PAGE

REPORT DOCUMENTATION PAGE				Form Approved OMB No. 0704-0188	
1a. REPORT SECURITY CLASSIFICATION UNCLASSIFIED			1b. RESTRICTIVE MARKINGS		
2a. SECURITY CLASSIFICATION AUTHORITY			3. DISTRIBUTION / AVAILABILITY OF REPORT Approved for public release; distribution is unlimited.		
2b. DECLASSIFICATION / DOWNGRADING SCHEDULE					
4. PERFORMING ORGANIZATION REPORT NUMBER(S) BRL-TR-3001			5. MONITORING ORGANIZATION REPORT NUMBER(S)		
6a. NAME OF PERFORMING ORGANIZATION US Army Ballistic Research Laboratory		6b. OFFICE SYMBOL (If applicable) SLCBR-DD-T	7a. NAME OF MONITORING ORGANIZATION		
6c. ADDRESS (City, State, and ZIP Code)  Aberdeen Proving Ground, MD 21005-5066			7b. ADDRESS (City, State, and ZIP Code)		
8a. NAME OF FUNDING / SPONSORING ORGANIZATION		8b. OFFICE SYMBOL (If applicable)	9. PROCUREMENT INSTRUMENT IDENTIFICATION NUMBER		
8c. ADDRESS (City, State, and ZIP Code)			10. SOURCE OF FUNDING NUMBERS		
			PROGRAM ELEMENT NO.	PROJECT NO.	TASK NO.
					WORK UNIT ACCESSION NO.
11. TITLE (Include Security Classification)  A Library of Digitized Flightpaths					
12. PERSONAL AUTHOR(S) Wald, Joseph K.					
13a. TYPE OF REPORT Final		13b. TIME COVERED FROM 1Jan89 TO 31Jan89		14. DATE OF REPORT (Year, Month, Day) February 1989	15. PAGE COUNT 108
16. SUPPLEMENTARY NOTATION					
17. COSATI CODES			18. SUBJECT TERMS (Continue on reverse if necessary and identify by block number)		
FIELD	GROUP	SUB-GROUP	Digitized flightpaths, simulation models, air defense, simulation validation, effectiveness analyses, rotary wing aircraft, fixed wing aircraft, optimal smoothing. (S) (S)		
01	03	01			
01	03	03			
19. ABSTRACT (Continue on reverse if necessary and identify by block number)  This report contains pictures of a variety of flightpaths developed from data collected over the last few years from several Army field tests of air defense weapon systems. The raw test data was subject to a smoothing process to produce flightpaths suitable for use in simulation validation efforts and effectiveness analyses.)					
20. DISTRIBUTION / AVAILABILITY OF ABSTRACT <input type="checkbox"/> UNCLASSIFIED/UNLIMITED <input checked="" type="checkbox"/> SAME AS RPT. <input type="checkbox"/> DTIC USERS			21. ABSTRACT SECURITY CLASSIFICATION UNCLASSIFIED		
22a. NAME OF RESPONSIBLE INDIVIDUAL Dr. Joseph K. Wald			22b. TELEPHONE (Include Area Code) 301-278-6669	22c. OFFICE SYMBOL SLCBR-SE-B	

DD Form 1473, JUN 86

Previous editions are obsolete.

SECURITY CLASSIFICATION OF THIS PAGE  
UNCLASSIFIED

## TABLE OF CONTENTS

	Page
LIST OF FIGURES.....	5
I. INTRODUCTION.....	9
II. METHODOLOGY DESCRIPTION.....	9
III. THE FLIGHTPATHS.....	10
DISTRIBUTION LIST .....	107

Accession For	
NTIS CRA&I	<input checked="" type="checkbox"/>
DTIC TAB	<input checked="" type="checkbox"/>
Unannounced	<input type="checkbox"/>
Justification	
By _____	
Distribution/	
Availability Codes	
Dist	Avail and/or Special
A-1	



The following page is blank.

## LIST OF FIGURES

	Page
1. Flightpath 1: Low Angle View.....	11
2. Flightpath 1: High Angle View.....	12
3. Flightpath 1: Position.....	13
4. Flightpath 1: Velocity.....	14
5. Flightpath 1: Acceleration.....	15
6. Flightpath 1: Attitude Angles .....	16
7. Flightpath 2: Low Angle View.....	17
8. Flightpath 2: High Angle View.....	18
9. Flightpath 2: Position.....	19
10. Flightpath 2: Velocity.....	20
11. Flightpath 2: Acceleration.....	21
12. Flightpath 2: Attitude Angles .....	22
13. Flightpath 3: Low Angle View.....	23
14. Flightpath 3: High Angle View.....	24
15. Flightpath 3: Position.....	25
16. Flightpath 3: Velocity.....	26
17. Flightpath 3: Acceleration.....	27
18. Flightpath 3: Attitude Angles .....	28
19. Flightpath 4: Low Angle View.....	29
20. Flightpath 4: High Angle View.....	30
21. Flightpath 4: Position.....	31
22. Flightpath 4: Velocity.....	32
23. Flightpath 4: Acceleration.....	33
24. Flightpath 4: Attitude Angles .....	34
25. Flightpath 5: Low Angle View.....	35
26. Flightpath 5: High Angle View.....	36
27. Flightpath 5: Position.....	37
28. Flightpath 5: Velocity.....	38
29. Flightpath 5: Acceleration.....	39
30. Flightpath 5: Attitude Angles .....	40
31. Flightpath 6: Low Angle View.....	41

## LIST OF FIGURES (Cont'd)

	Page
32. Flightpath 6: High Angle View.....	42
33. Flightpath 6: Position.....	43
34. Flightpath 6: Velocity.....	44
35. Flightpath 6: Acceleration.....	45
36. Flightpath 6: Attitude Angles .....	46
37. Flightpath 7: Low Angle View.....	47
38. Flightpath 7: High Angle View.....	48
39. Flightpath 7: Position.....	49
40. Flightpath 7: Velocity.....	50
41. Flightpath 7: Acceleration.....	51
42. Flightpath 7: Attitude Angles .....	52
43. Flightpath 8: Low Angle View.....	53
44. Flightpath 8: High Angle View.....	54
45. Flightpath 8: Position.....	55
46. Flightpath 8: Velocity.....	56
47. Flightpath 8: Acceleration.....	57
48. Flightpath 8: Attitude Angles .....	58
49. Flightpath 9: Low Angle View.....	59
50. Flightpath 9: High Angle View.....	60
51. Flightpath 9: Position.....	61
52. Flightpath 9: Velocity.....	62
53. Flightpath 9: Acceleration.....	63
54. Flightpath 9: Attitude Angles .....	64
55. Flightpath 10: Low Angle View.....	65
56. Flightpath 10: High Angle View.....	66
57. Flightpath 10: Position.....	67
58. Flightpath 10: Velocity.....	68
59. Flightpath 10: Acceleration.....	69
60. Flightpath 10: Attitude Angles .....	70
61. Flightpath 11: Low Angle View.....	71
62. Flightpath 11: High Angle View.....	72

## LIST OF FIGURES (Cont'd)

	Page
63. Flightpath 11: Position.....	73
64. Flightpath 11: Velocity.....	74
65. Flightpath 11: Acceleration.....	75
66. Flightpath 11: Attitude Angles .....	76
67. Flightpath 12: Low Angle View.....	77
68. Flightpath 12: High Angle View.....	78
69. Flightpath 12: Position.....	79
70. Flightpath 12: Velocity.....	80
71. Flightpath 12: Acceleration.....	81
72. Flightpath 12: Attitude Angles .....	82
73. Flightpath 13: Low Angle View.....	83
74. Flightpath 13: High Angle View.....	84
75. Flightpath 13: Position.....	85
76. Flightpath 13: Velocity.....	86
77. Flightpath 13: Acceleration.....	87
78. Flightpath 13: Attitude Angles .....	88
79. Flightpath 14: Low Angle View.....	89
80. Flightpath 14: High Angle View.....	90
81. Flightpath 14: Position.....	91
82. Flightpath 14: Velocity.....	92
83. Flightpath 14: Acceleration.....	93
84. Flightpath 14: Attitude Angles .....	94
85. Flightpath 15: Low Angle View.....	95
86. Flightpath 15: High Angle View.....	96
87. Flightpath 15: Position.....	97
88. Flightpath 15: Velocity.....	98
89. Flightpath 15: Acceleration.....	99
90. Flightpath 15: Attitude Angles .....	100
91. Flightpath 16: Low Angle View.....	101
92. Flightpath 16: High Angle View.....	102
93. Flightpath 16: Position.....	103

LIST OF FIGURES (Cont'd)

	Page
94. Flightpath 16: Velocity.....	104
95. Flightpath 16: Acceleration.....	105
96. Flightpath 16: Attitude Angles .....	106

# A Library Of Digitized Flightpaths

Dr. Joseph K. Wald

## I. INTRODUCTION

Digitized flightpaths are required input to detailed simulation models for a number of air defense weapon systems, both guns and missiles. Generally speaking, the more detailed and extensive the modeling of the fire control in such models, the more detailed and realistic the flightpaths should be. Sometimes mathematically generated flightpaths are used, but unless these are constructed in a rather sophisticated way, they lack the proper frequency content and plant noise reflected in flightpaths flown by real pilots in real aircraft.

In this report we present pictures of a variety of flightpaths we have collected over the last few years from a number of Army field tests of air defense weapon systems. After undergoing a smoothing process, these flightpaths have been used in simulation validation efforts and effectiveness analyses.

## II. METHODOLOGY DESCRIPTION

The raw data for the flightpaths contained in this collection were recorded in tests conducted at Ft. Bliss, Texas and Ft. Hunter Liggett, California. The rotary wing aircraft were typically UH1s and the fixed wing aircraft were typically A7s with an occasional F100 or A10. The equipment used to collect the raw target position data was usually radar or cinetheodolites. To remove the "measurement noise" from the raw data, we used a double sweep optimal smoothing technique<sup>1</sup> that simultaneously produces position, velocity, and acceleration estimates in the x, y, and z coordinates. For each flightpath, the time interval between successive data points is 0.05 seconds.

There were typically no attitude sensors on board the aircraft during these tests, so we had to calculate the aircraft attitude angles (roll, pitch, and yaw) analytically. For the fixed wing aircraft, we added the target attitude angles under the assumption that the longitudinal axis of the aircraft coincided with its velocity vector - i.e., there was no angle of attack. For the aircraft and flight profiles under consideration, this was generally a good assumption. We made the same assumption in those cases in which the helicopter had a significant forward velocity. For the hovering helicopters, we made the assumption that the helicopter had no pitch or roll, and that the aircraft would orient itself to present a "nose-on" view to its target, which was presumed to be at the origin of the coordinate system.

<sup>1</sup>Scheder, Robert A., A Computer Program For Double Sweep Optimal Smoothing (U), U.S. Army Materiel Systems Analysis Activity Technical Report No. 246, January, 1979. UNCLASSIFIED.

### III. THE FLIGHTPATHS

There are sixteen flightpaths in this collection, nine flown by fixed wing aircraft and seven by helicopters. A number of different ground attack maneuvers are represented in this collection. These are summarized in Table 1.

TABLE 1. Flightpath Summary.		
Flightpath	Aircraft	Maneuver
1	fixed wing	"pop-up, turn, and dive"
2	fixed wing	"pop-up, turn, and dive"
3	fixed wing	"straight and level"
4	fixed wing	"constant g turn"
5	fixed wing	"jink"
6	fixed wing	"pop-up, turn, and dive"
7	fixed wing	"straight and level"
8	fixed wing	"constant g turn"
9	helicopter	"hover"
10	helicopter	"hover"
11	helicopter	"hover"
12	helicopter	"hover"
13	helicopter	"straight and level"
14	helicopter	"constant g turn"
15	helicopter	"pop-up and shallow dive"
16	fixed wing	"turn and dive"

The flightpaths are depicted in figures 1 through 96. For each flightpath, there are two three dimensional views and time histories for each of the nine state variables and the attitude angles. In the three dimensional pictures, the x, y, and z axes are denoted by "east", "north", and "up" respectively, and the origin of the coordinate system lies at the center of the small rectangular box depicted in the ground plane. The small arrows indicate the direction of aircraft motion. Due to scaling problems in the case of the hovering helicopters, we have presented a close-up high angle view in which the solid circles represent the location of the "center" of the helicopter at one second intervals. This was done to give the reader a feel for the extent of both vertical and lateral motion of the helicopters when hovering.

The resolution of the data is one centimeter for the state variables and one tenth of a milliradian for the attitude angles. This causes some time histories to appear as "step functions" (see e.g., figure 53). Also, the restriction that the values of the FORTRAN ATAN2 function lie in the interval  $(-\pi, \pi)$  gives rise to the apparent instantaneous 360 degree "jump" that appears in some of the time histories of the attitude angles (see e.g., figure 6).

As data from future field tests becomes available, this library of flightpaths will be updated and expanded to include new aircraft and new maneuvers.

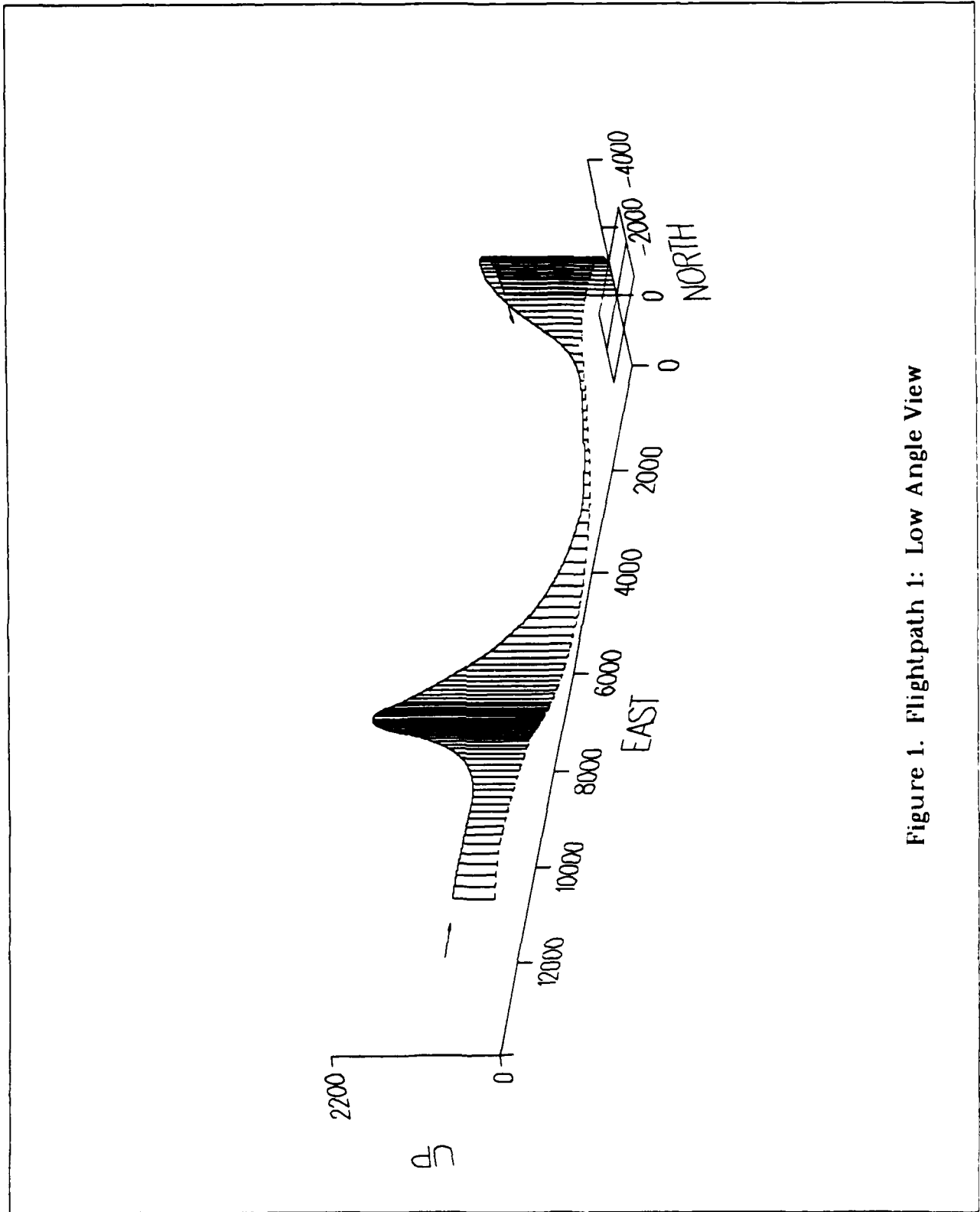

Figure 1. Flightpath 1: Low Angle View

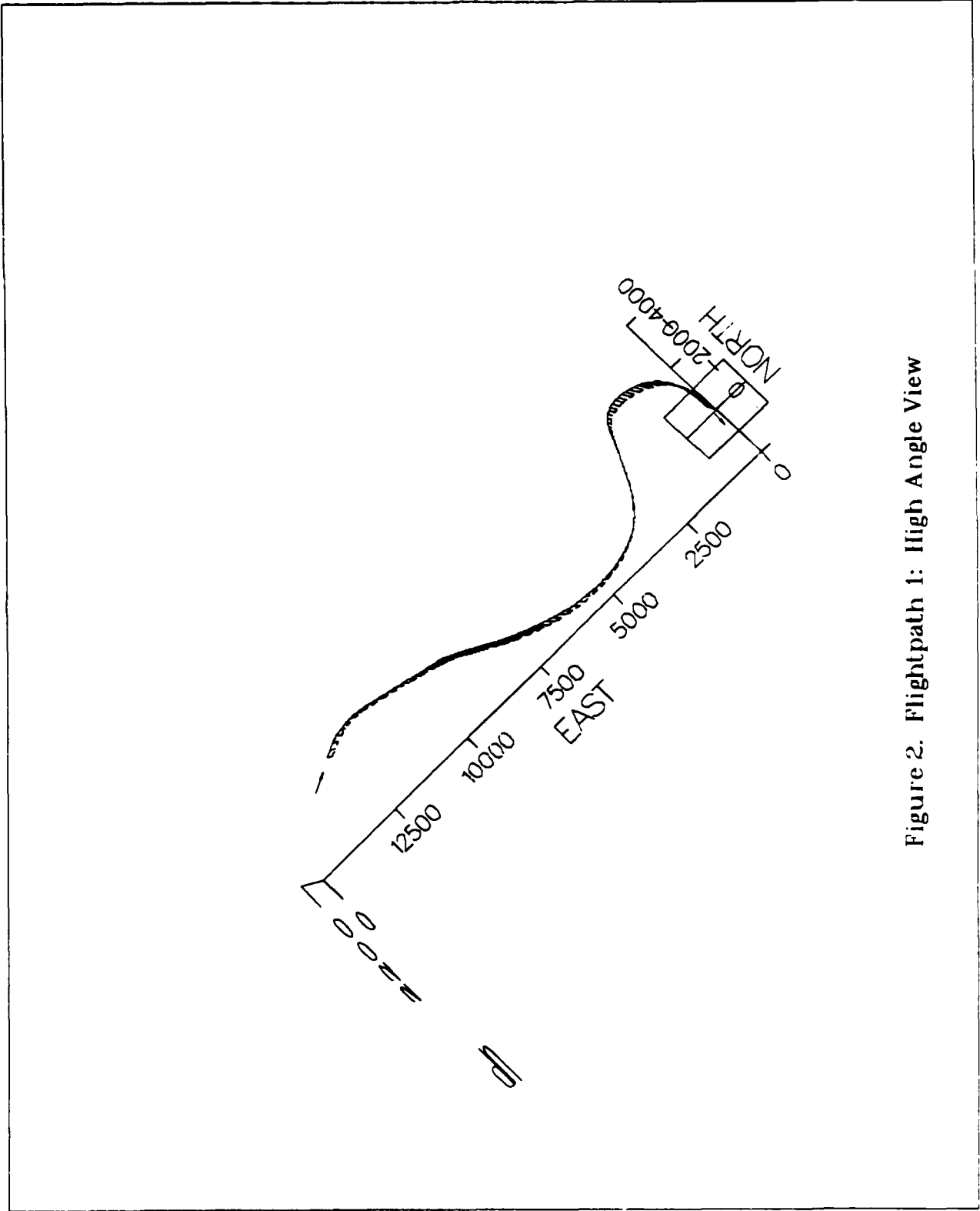

Figure 2. Flightpath 1: High Angle View

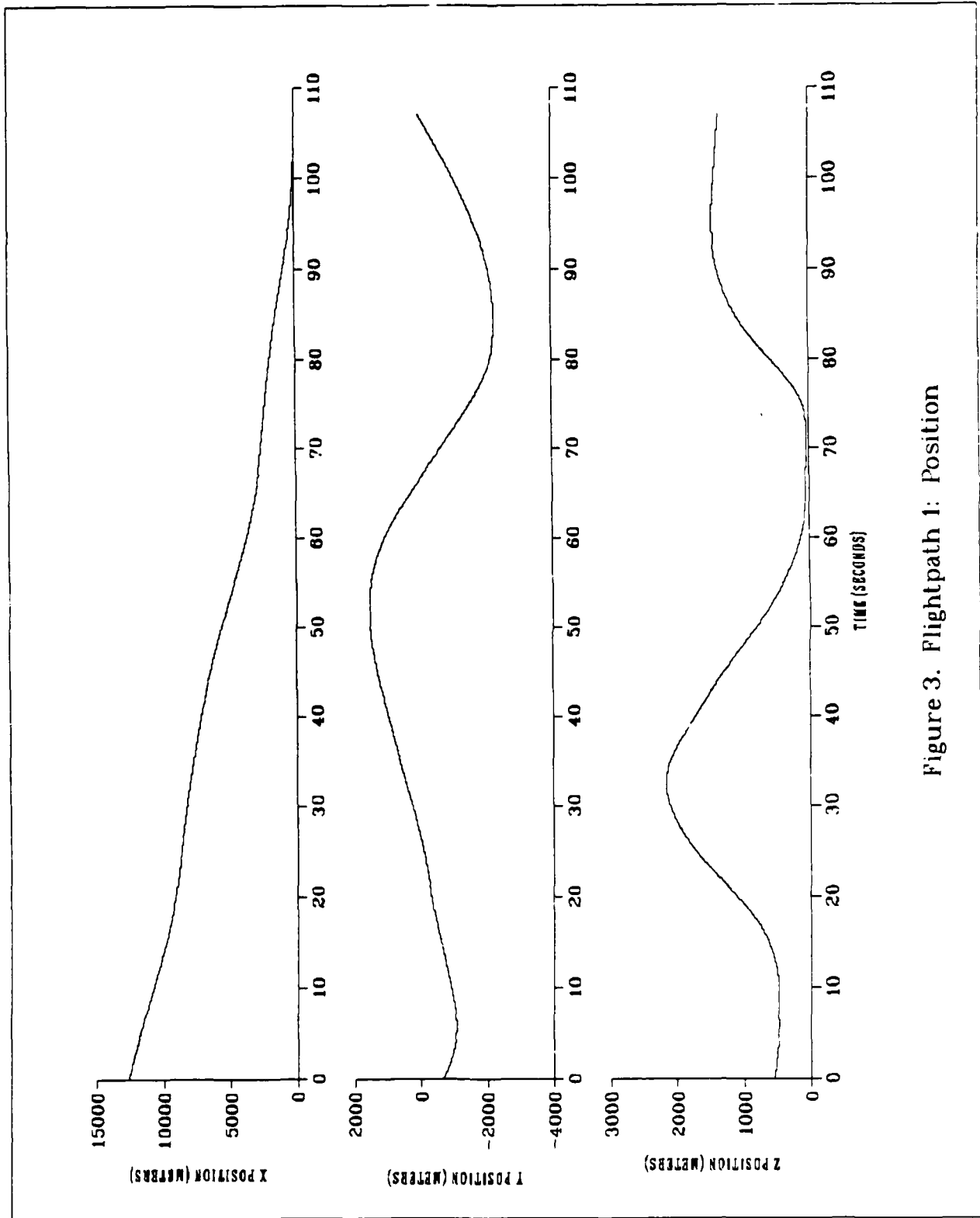

Figure 3. Flightpath 1: Position

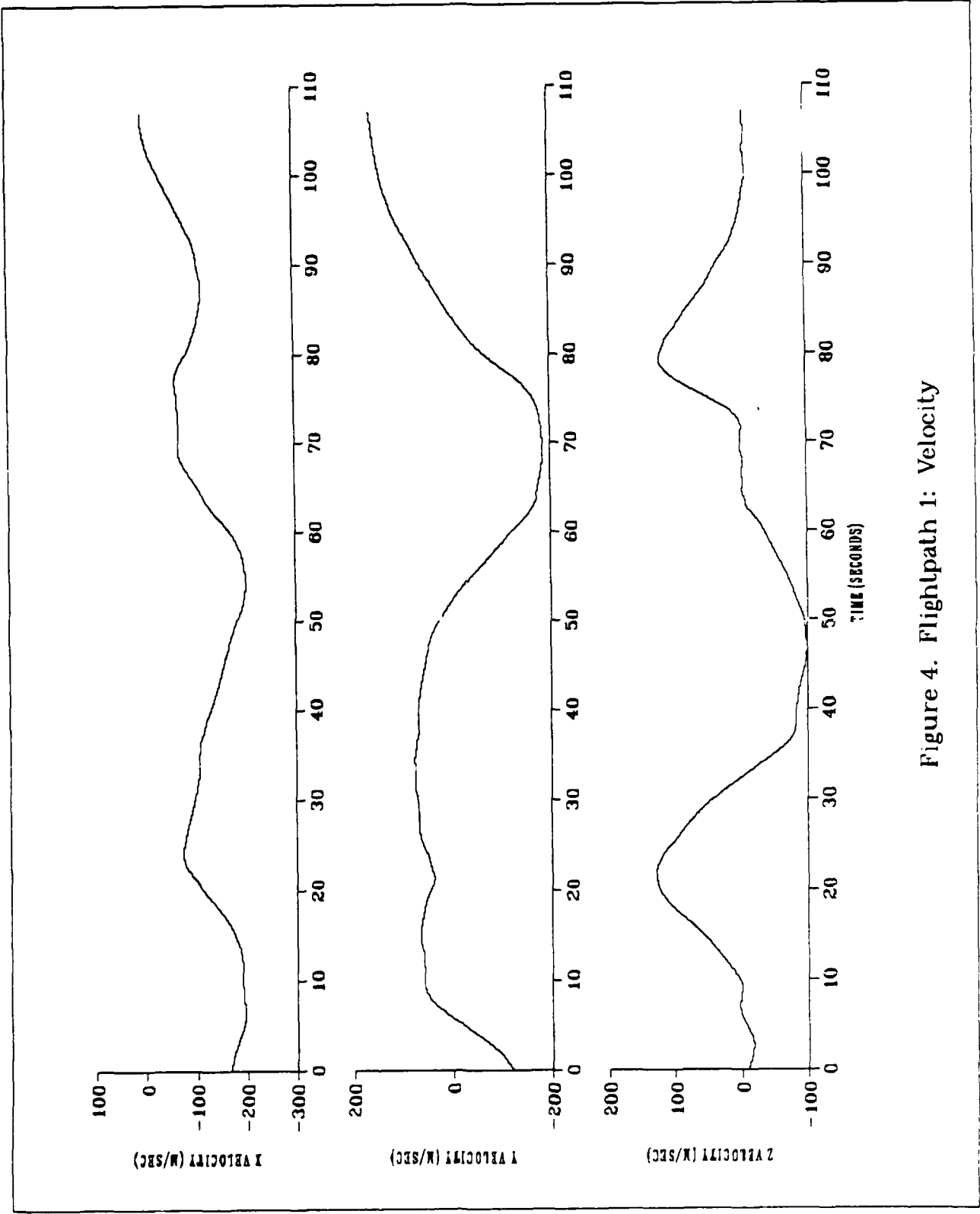

Figure 4. Flightpath 1: Velocity

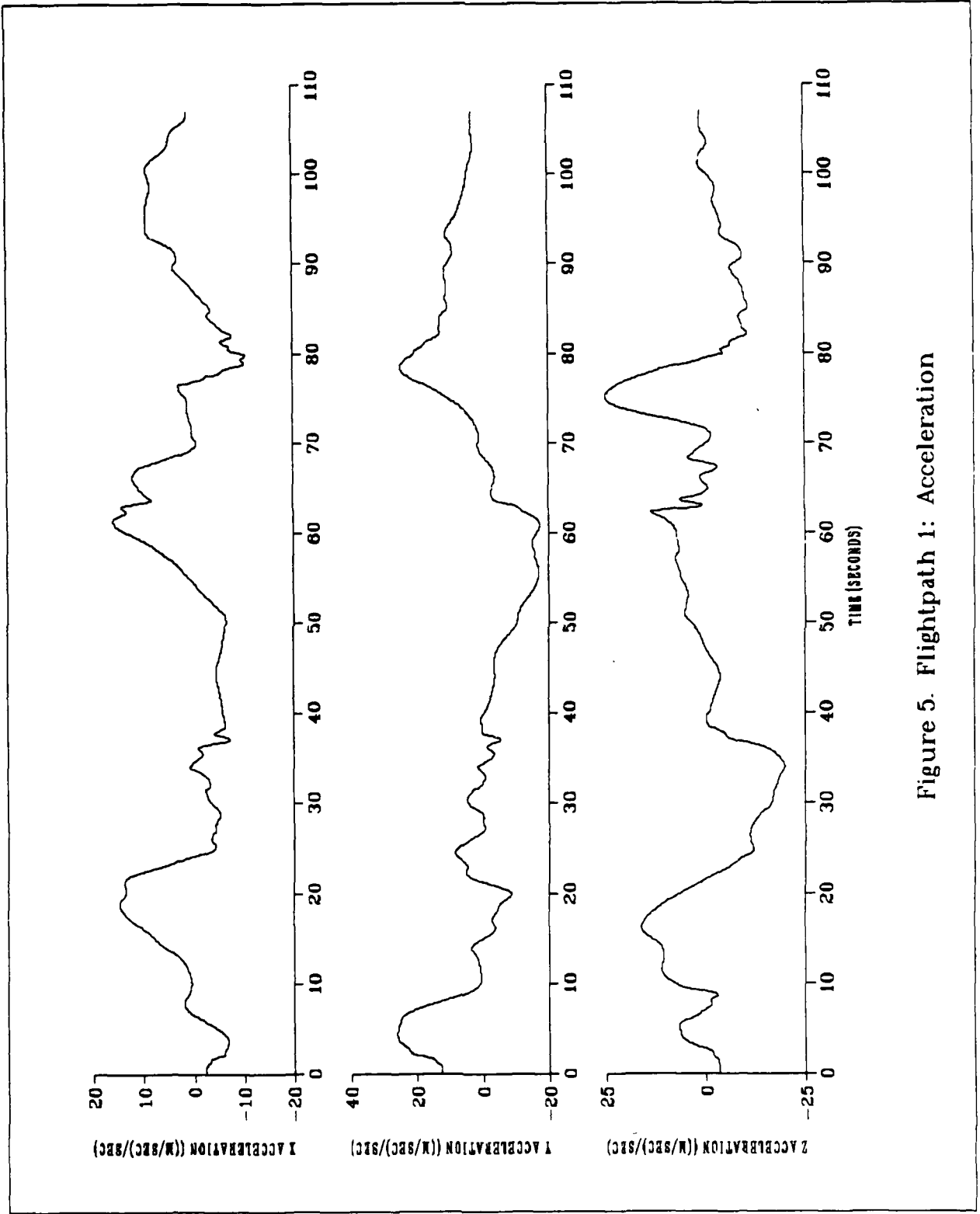

Figure 5. Flightpath 1: Acceleration

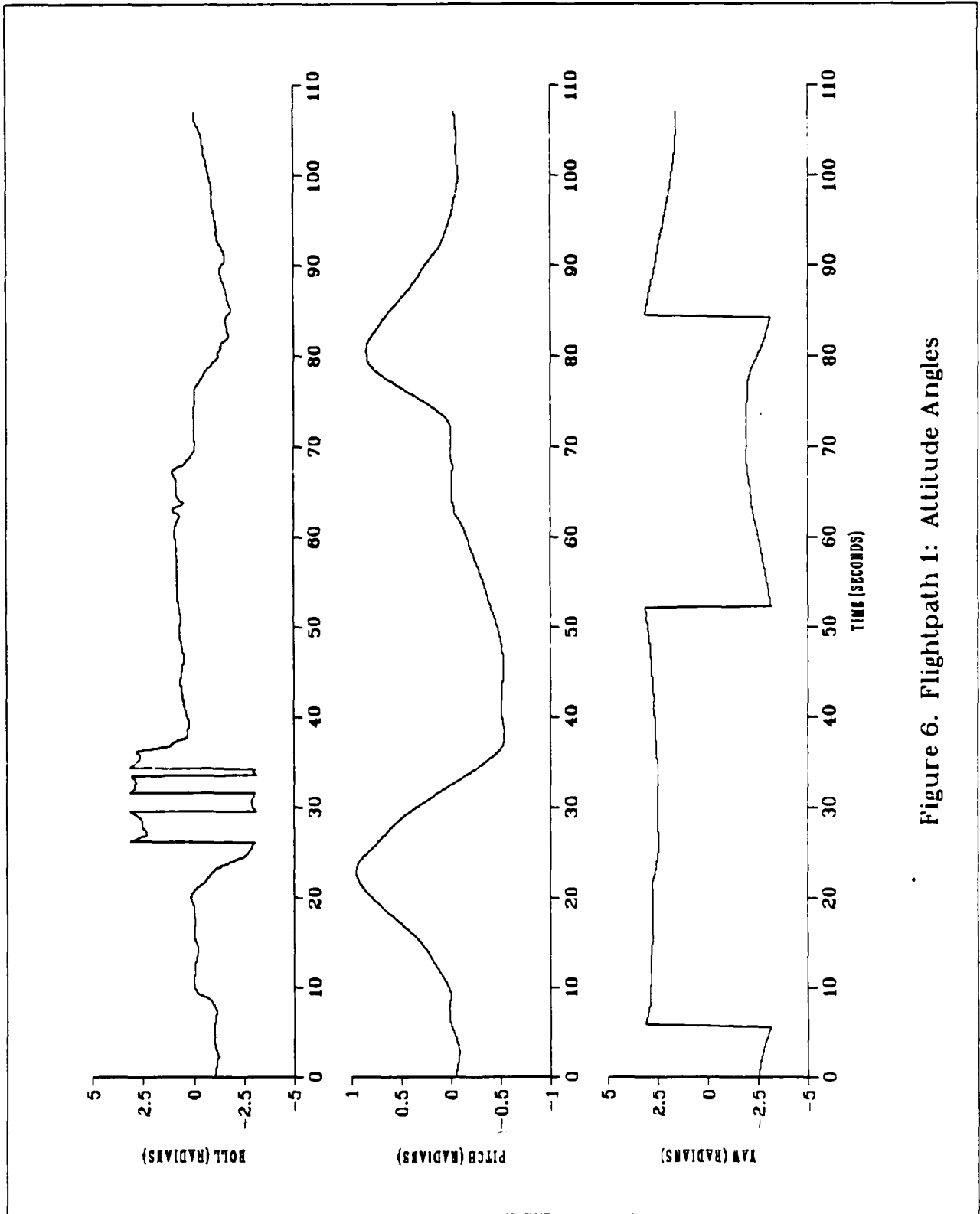

Figure 6. Flightpath 1: Altitude Angles

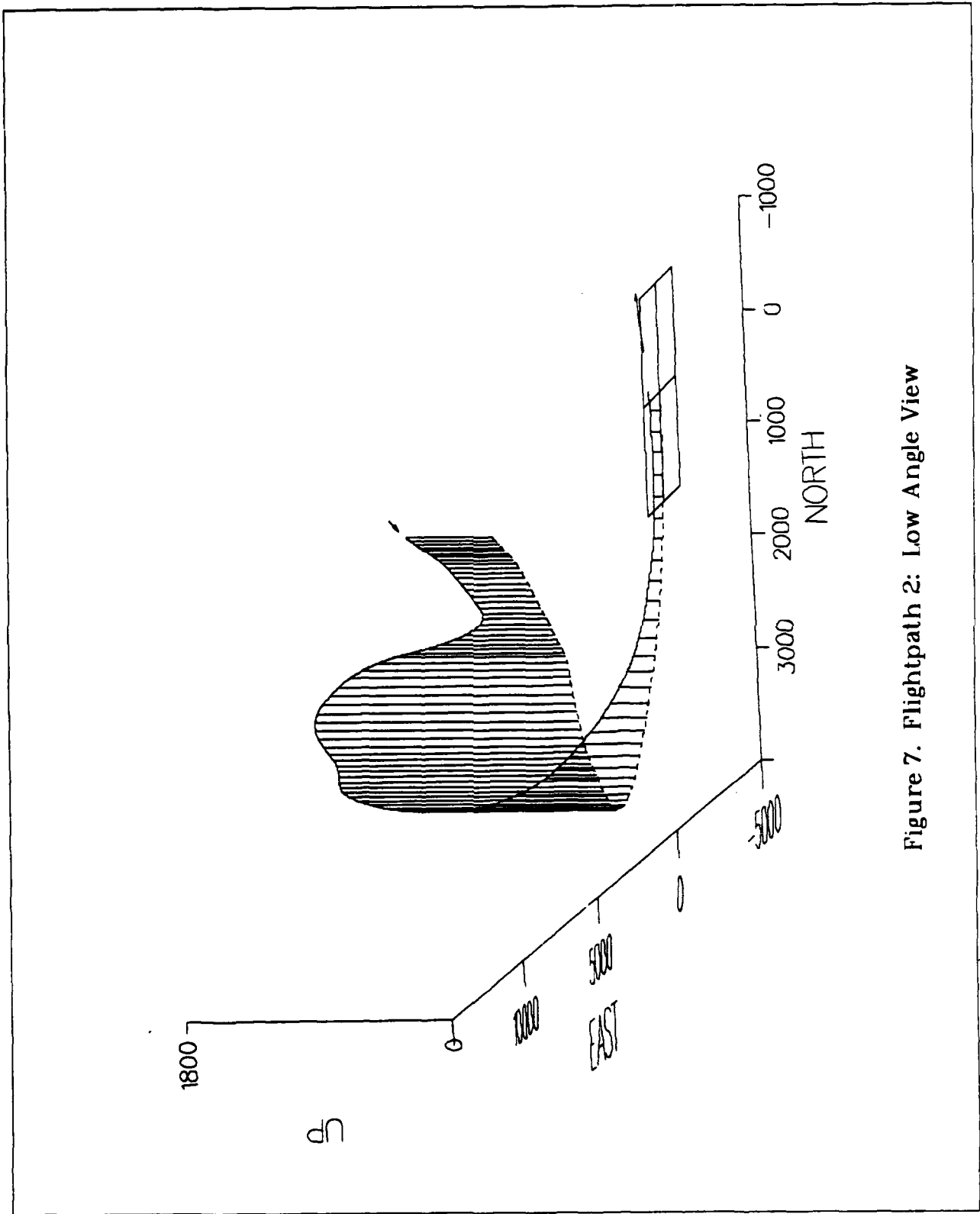

Figure 7. Flightpath 2: Low Angle View

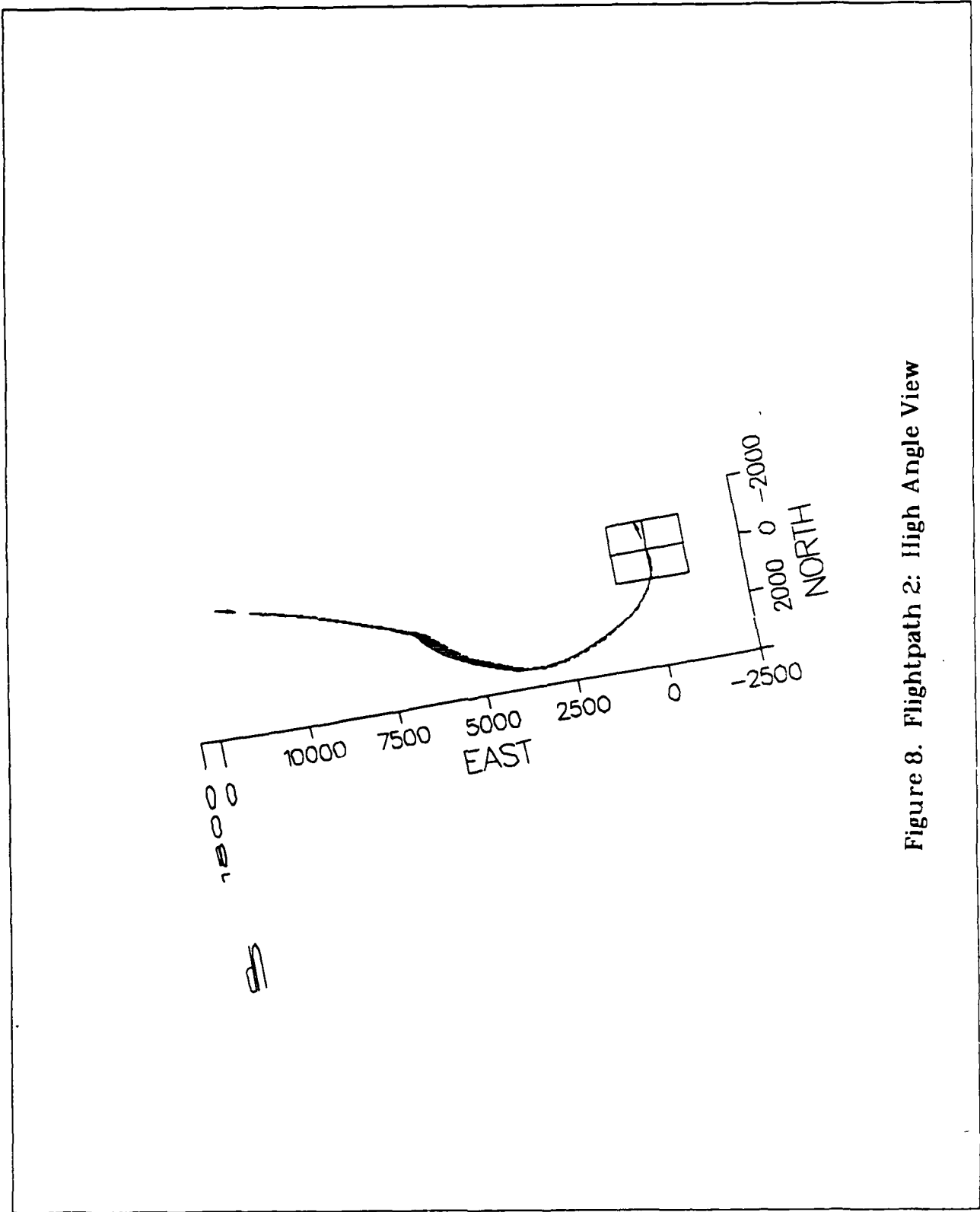

Figure 8. Flightpath 2: High Angle View

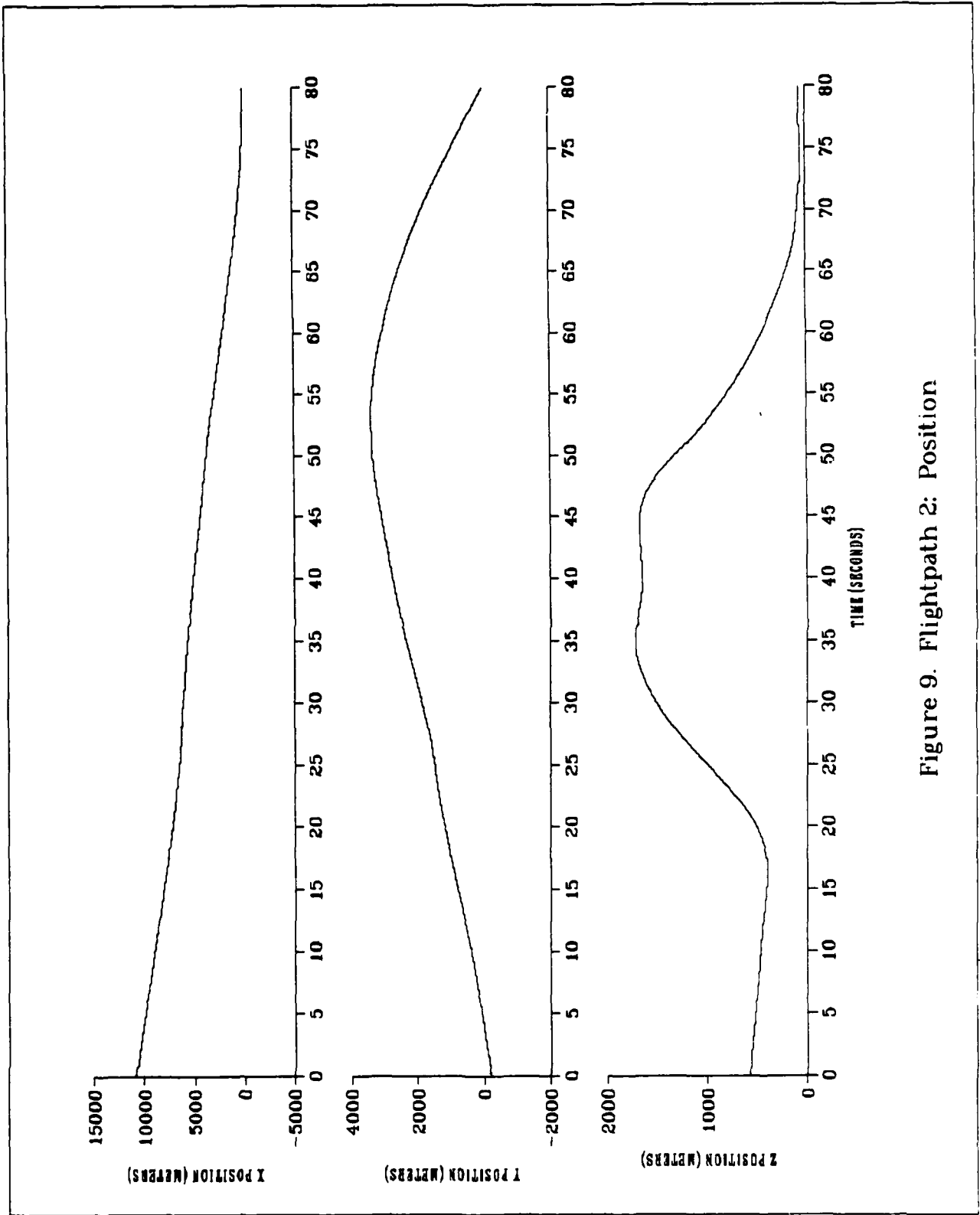

Figure 9. Flightpath 2: Position

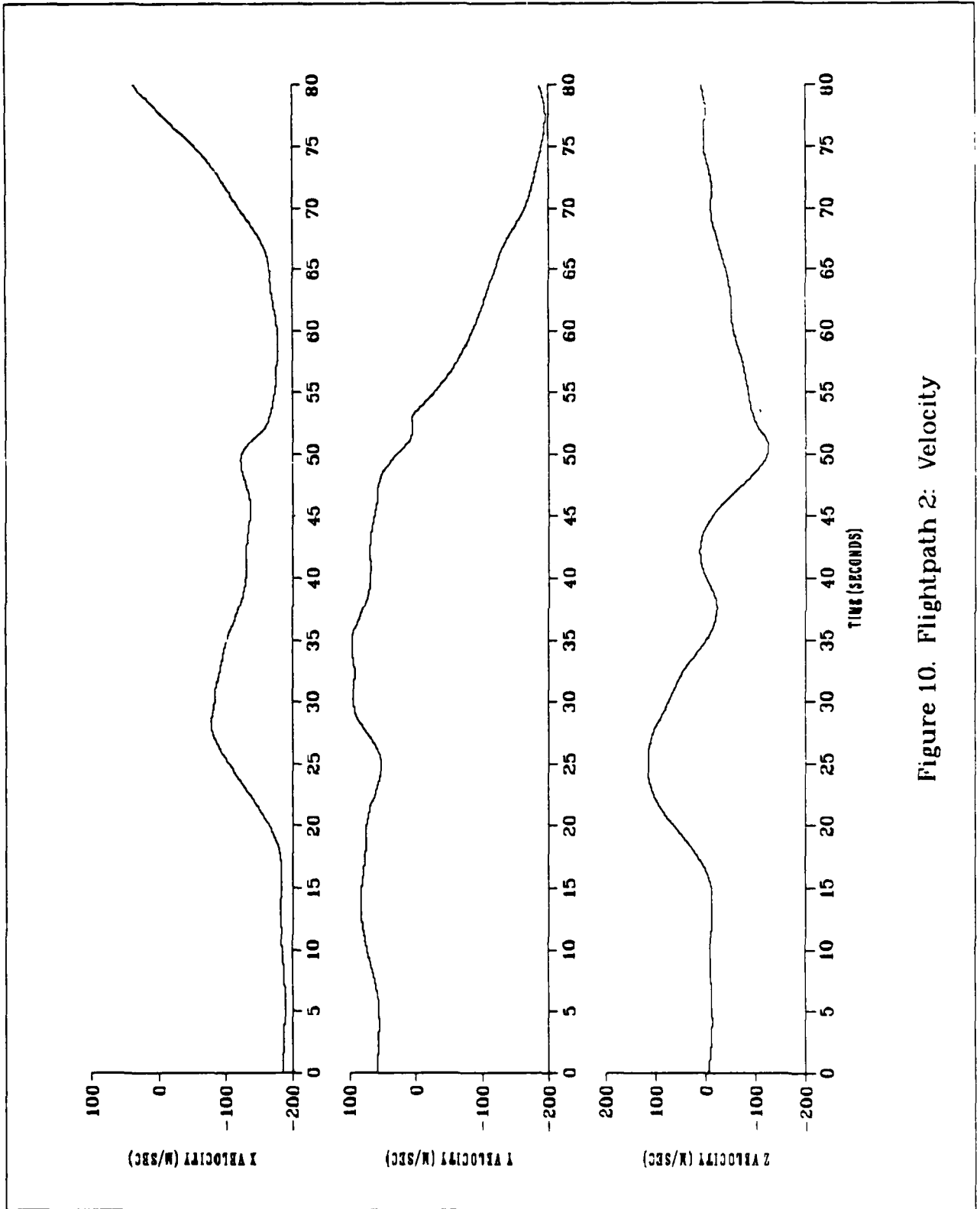

Figure 10. Flightpath 2: Velocity

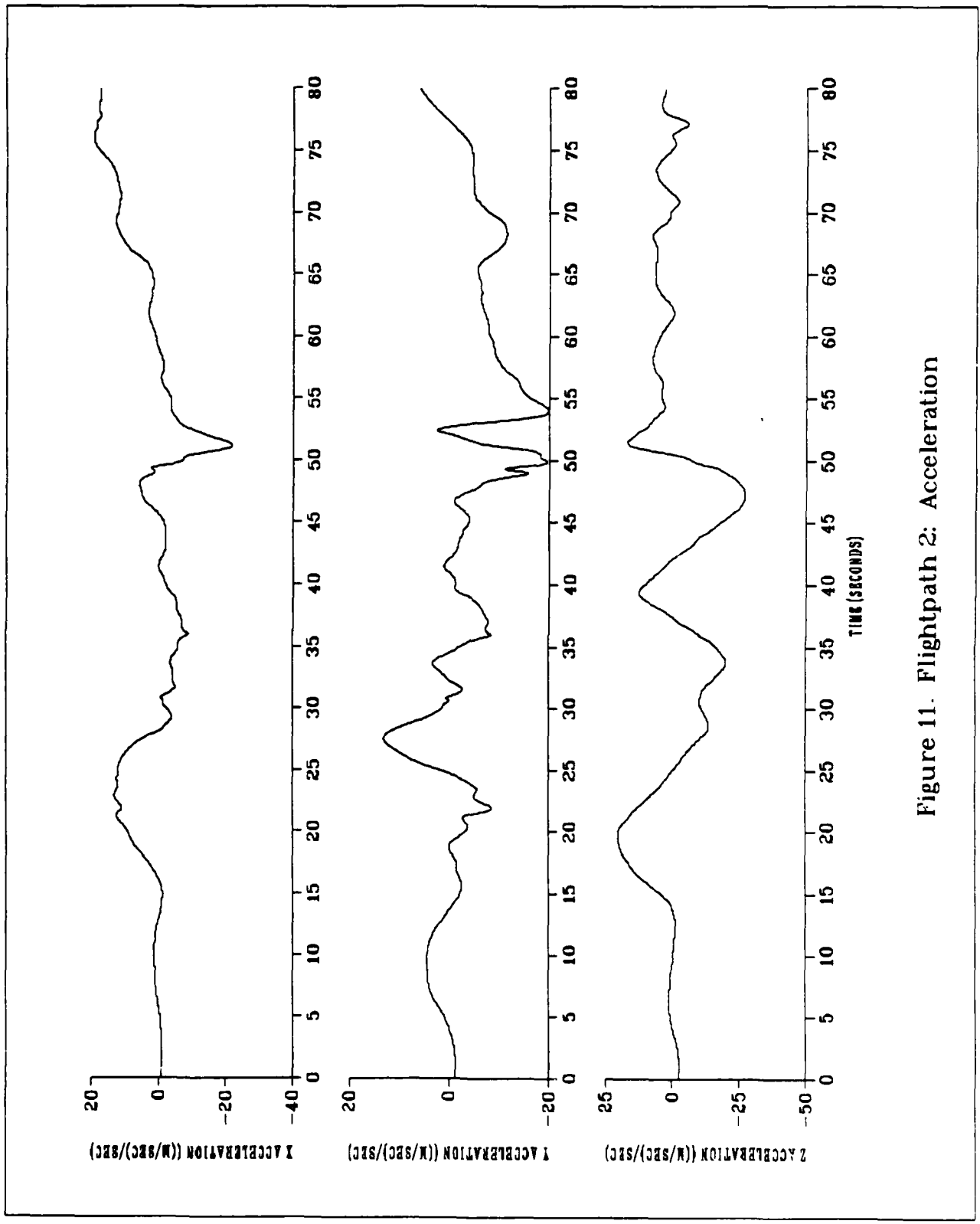

Figure 11. Flightpath 2: Acceleration

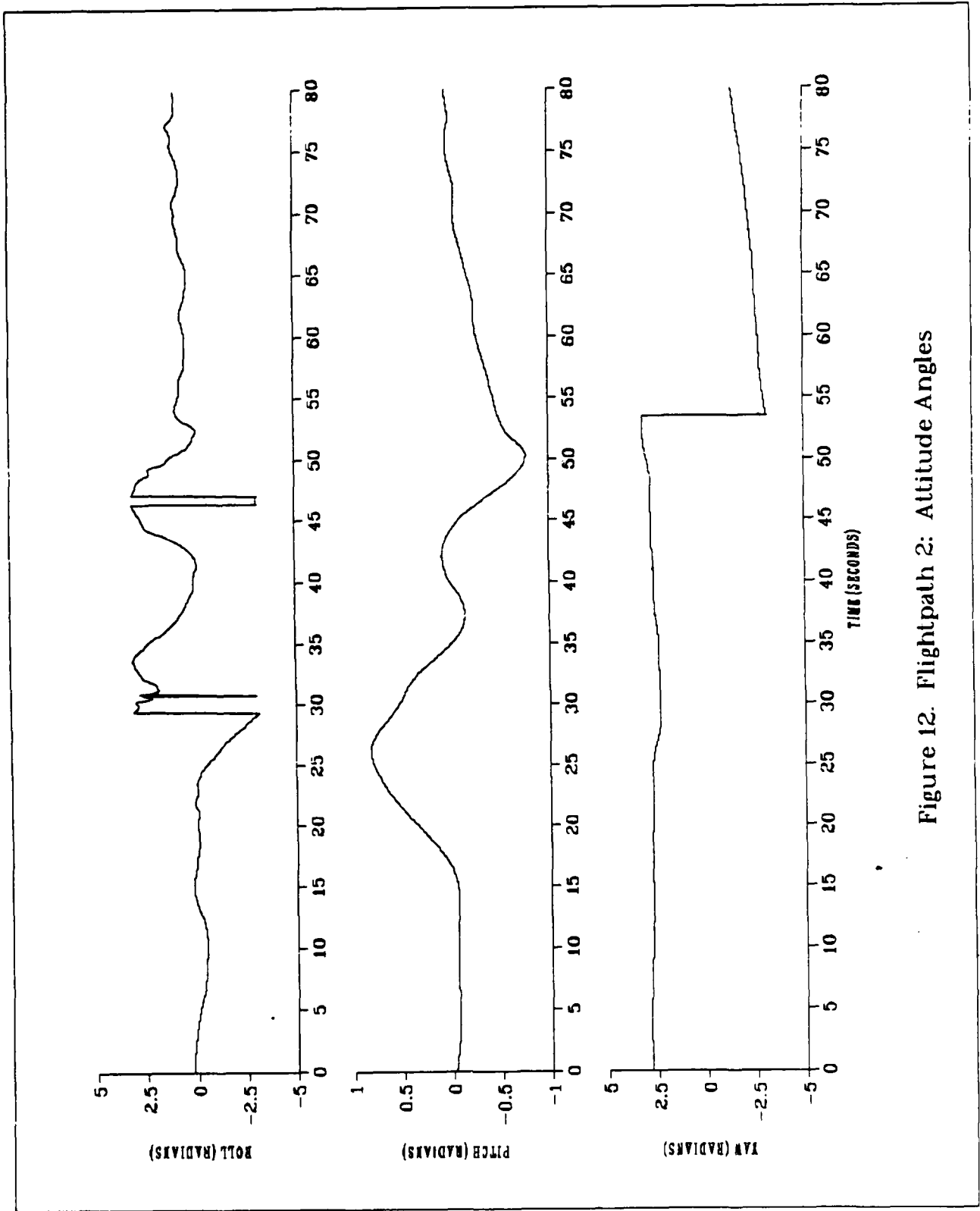

Figure 12. Flightpath 2: Attitude Angles

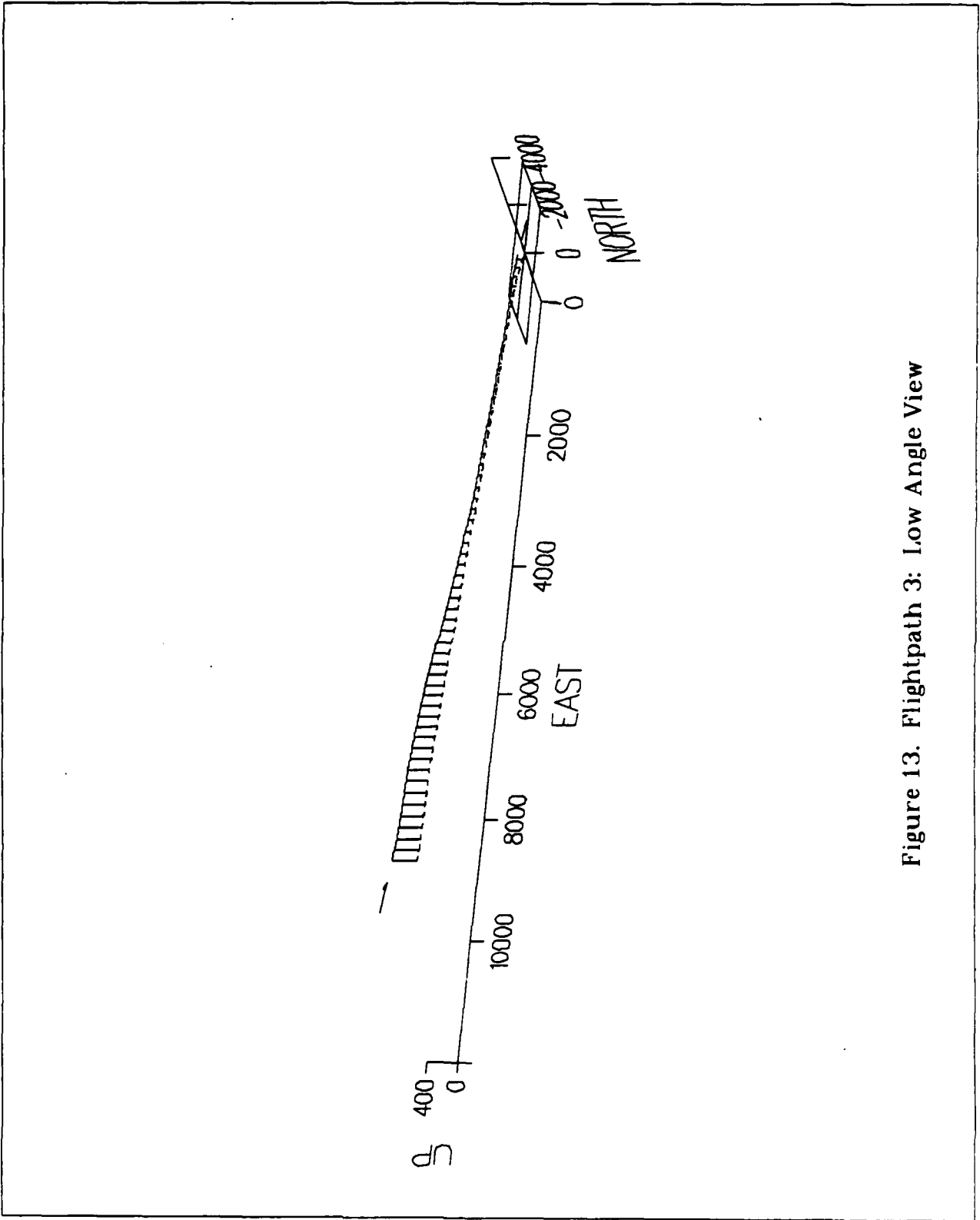

Figure 13. Flightpath 3: Low Angle View

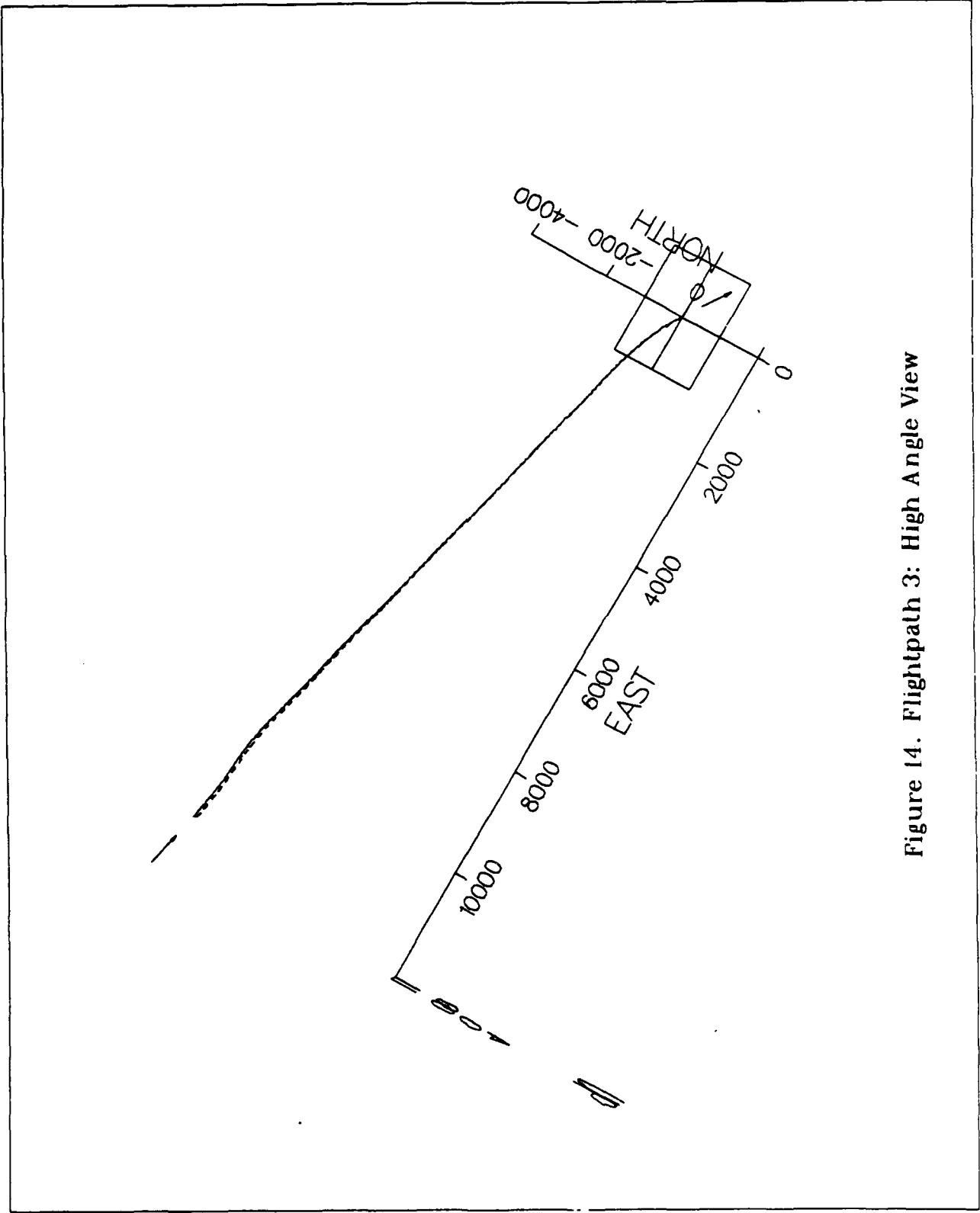

Figure 14. Flightpath 3: High Angle View

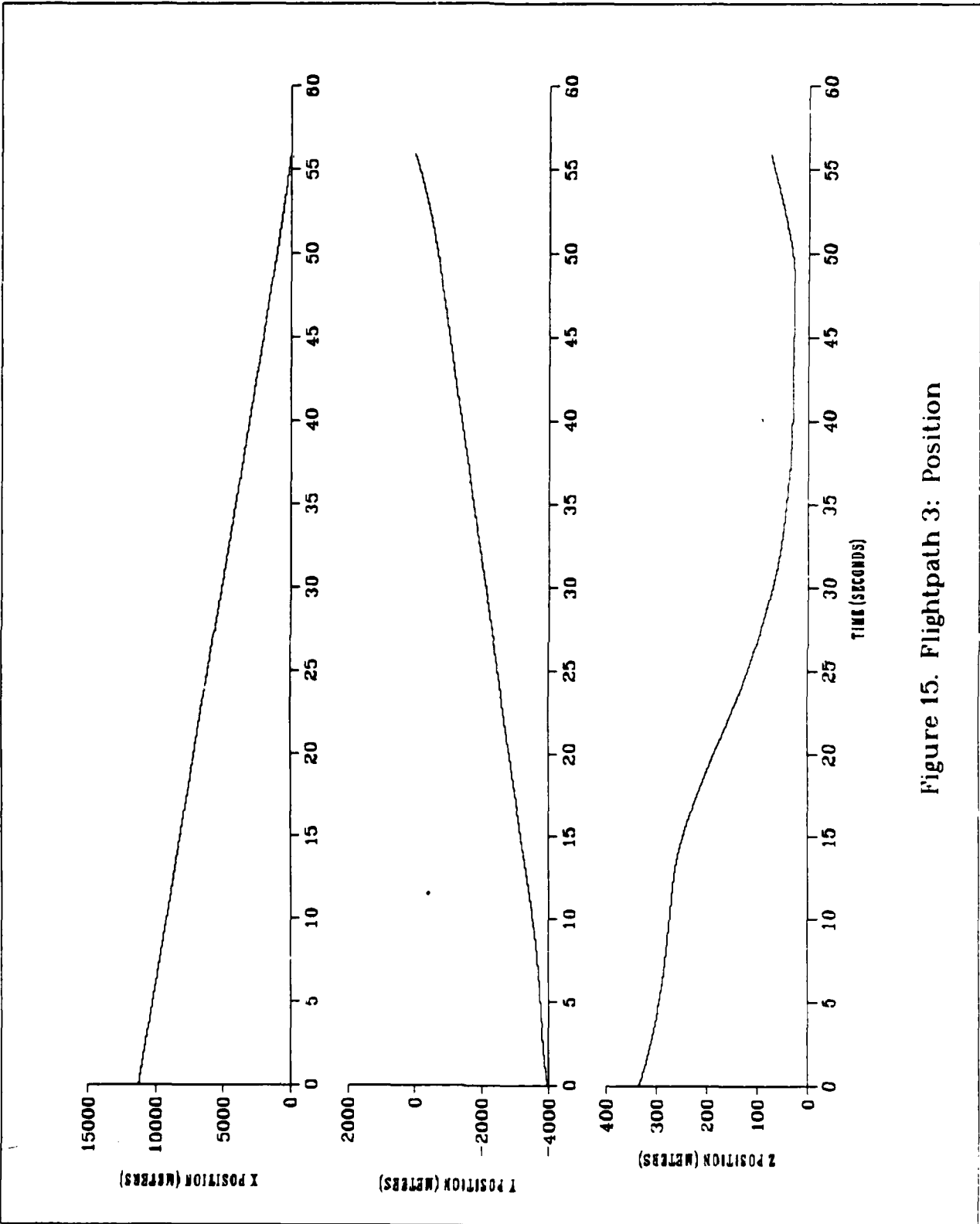

Figure 15. Flightpath 3: Position

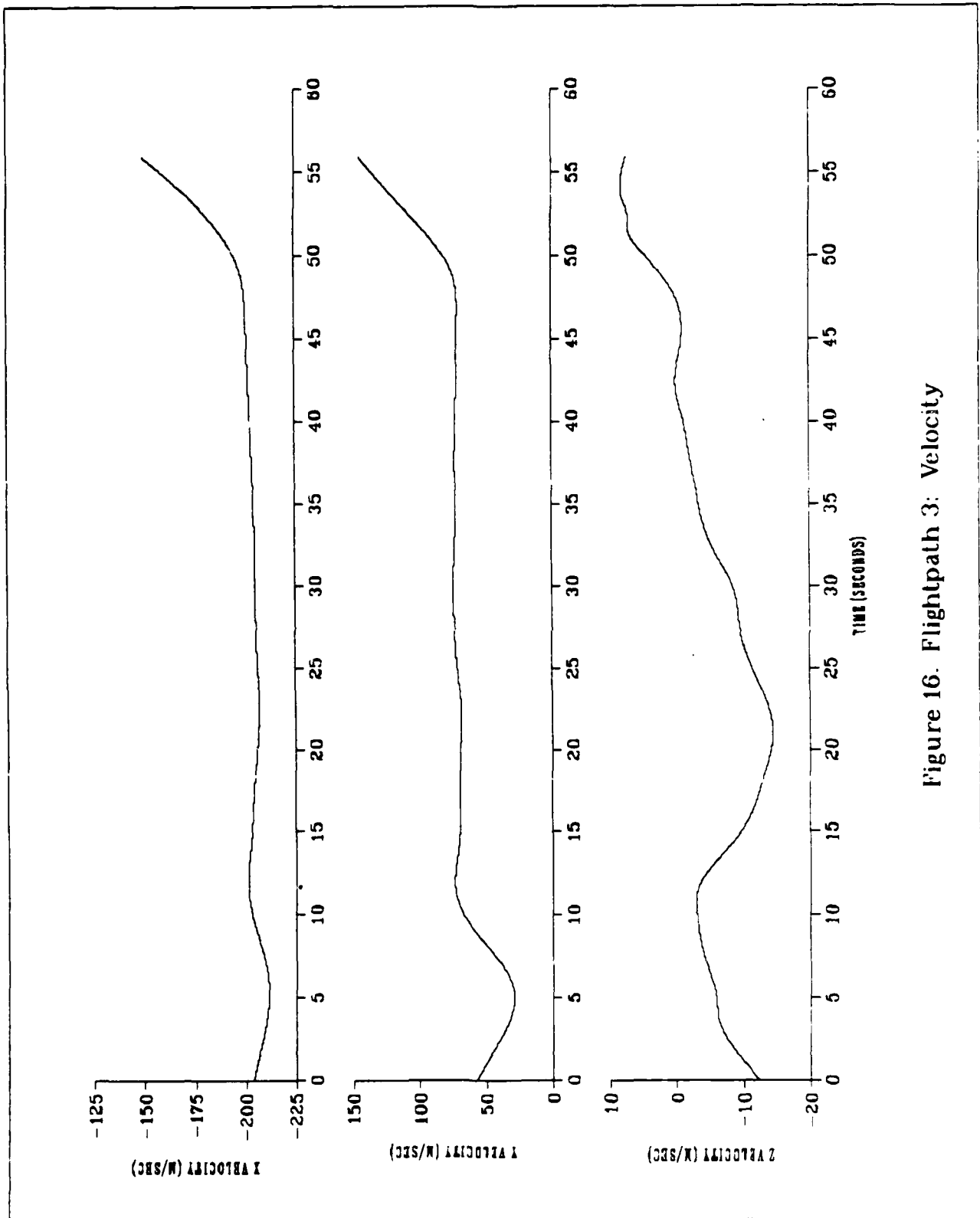

Figure 16. Flightpath 3: Velocity

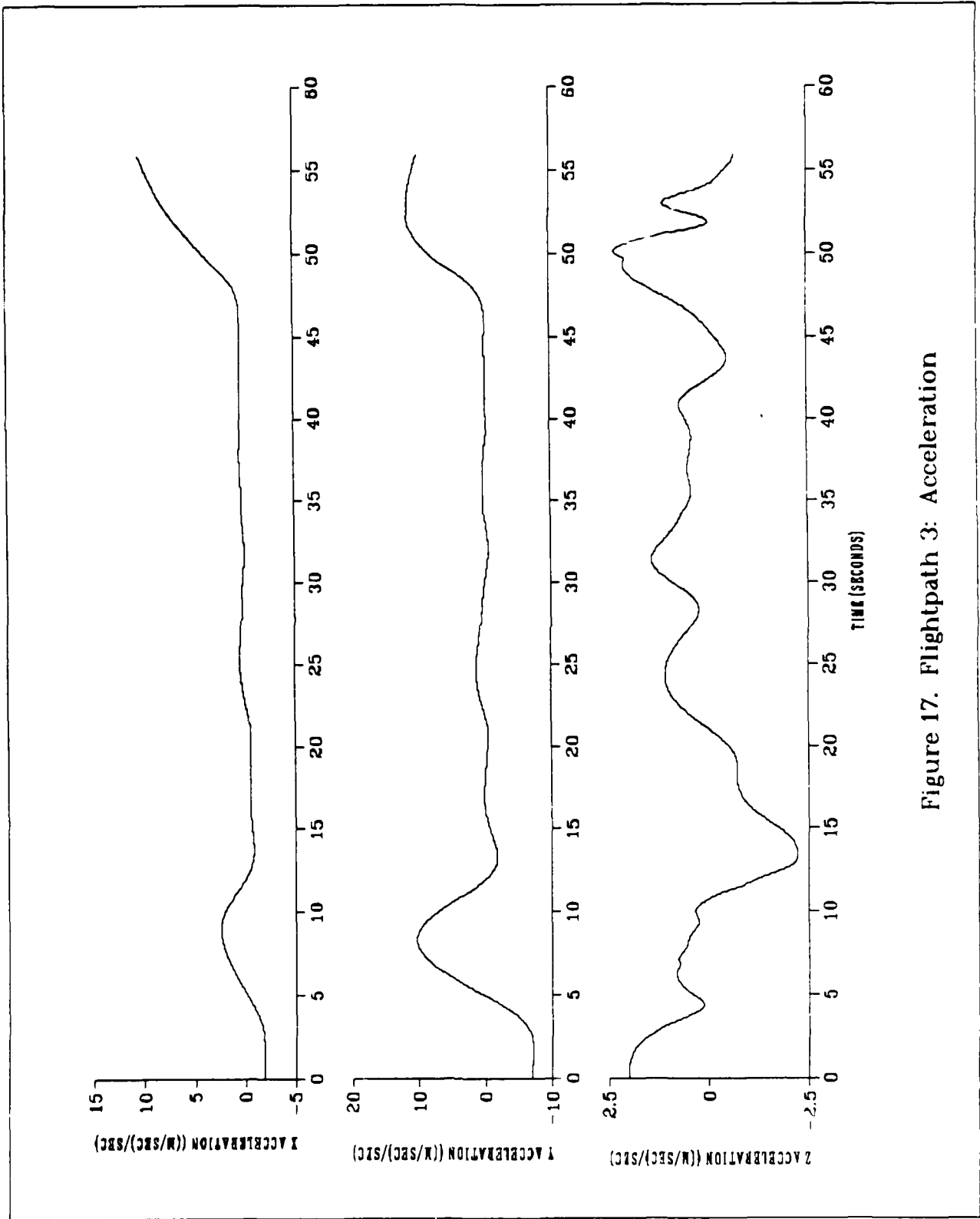

Figure 17. Flightpath 3: Acceleration

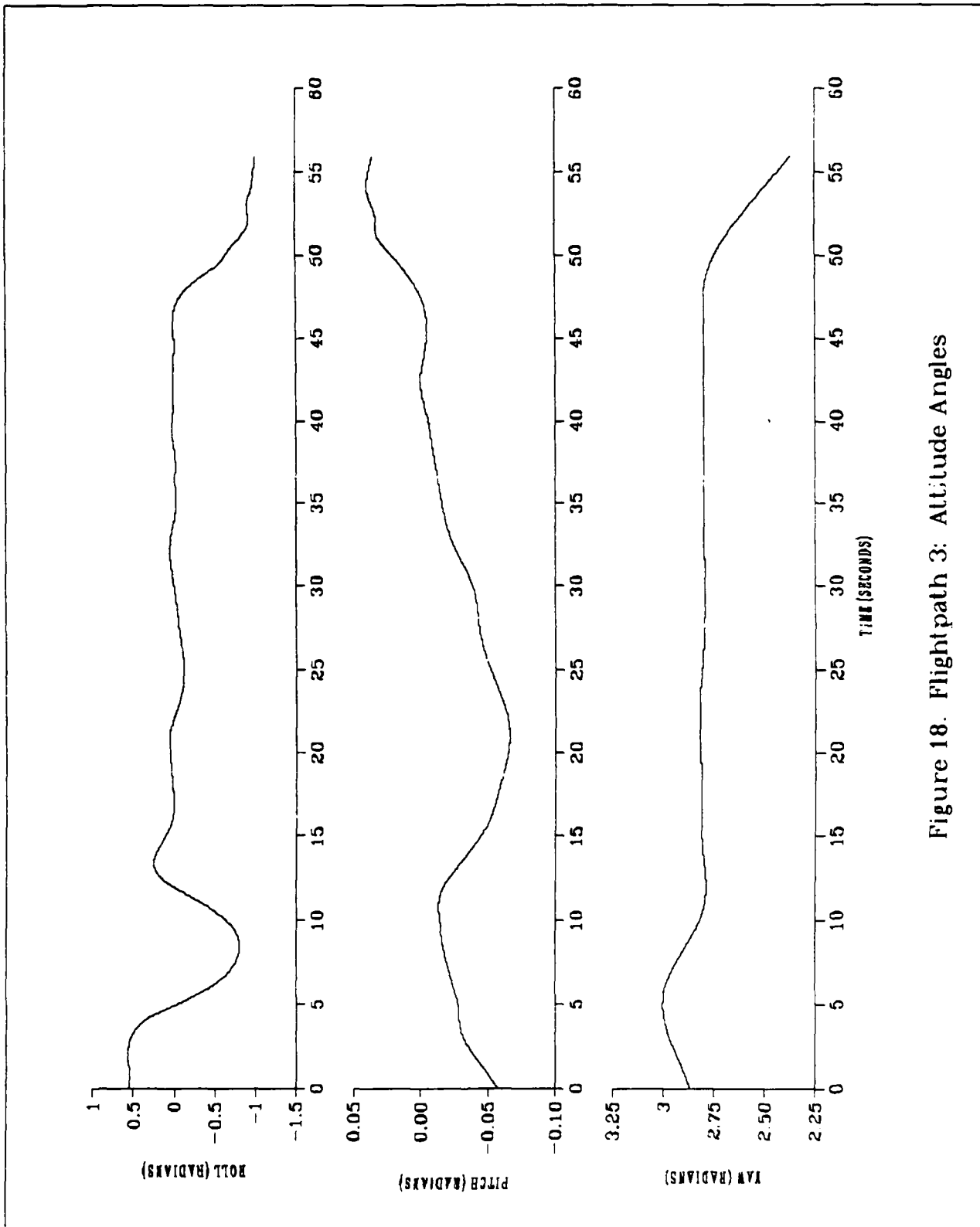

Figure 18. Flightpath 3: Altitude Angles

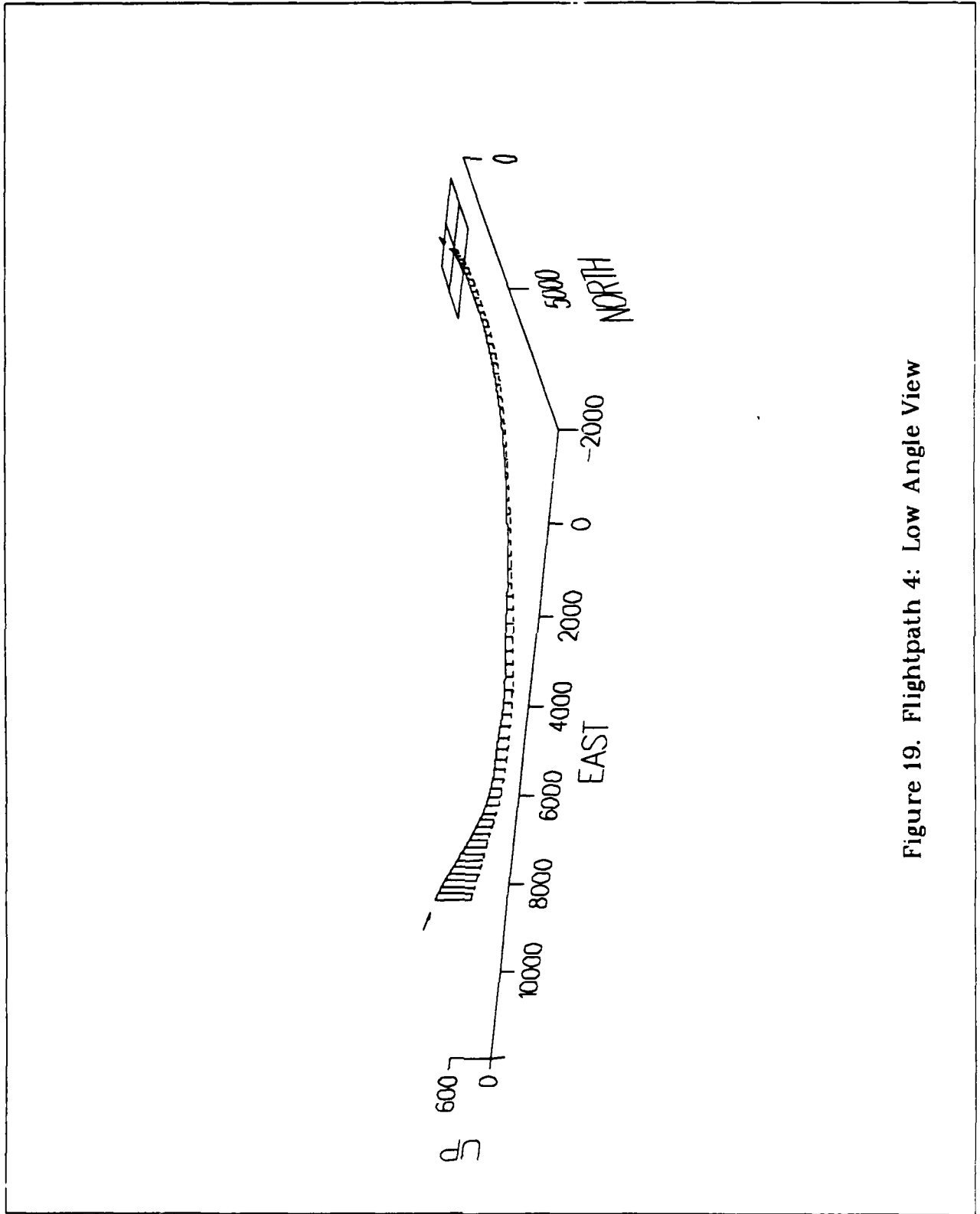

Figure 19. Flightpath 4: Low Angle View

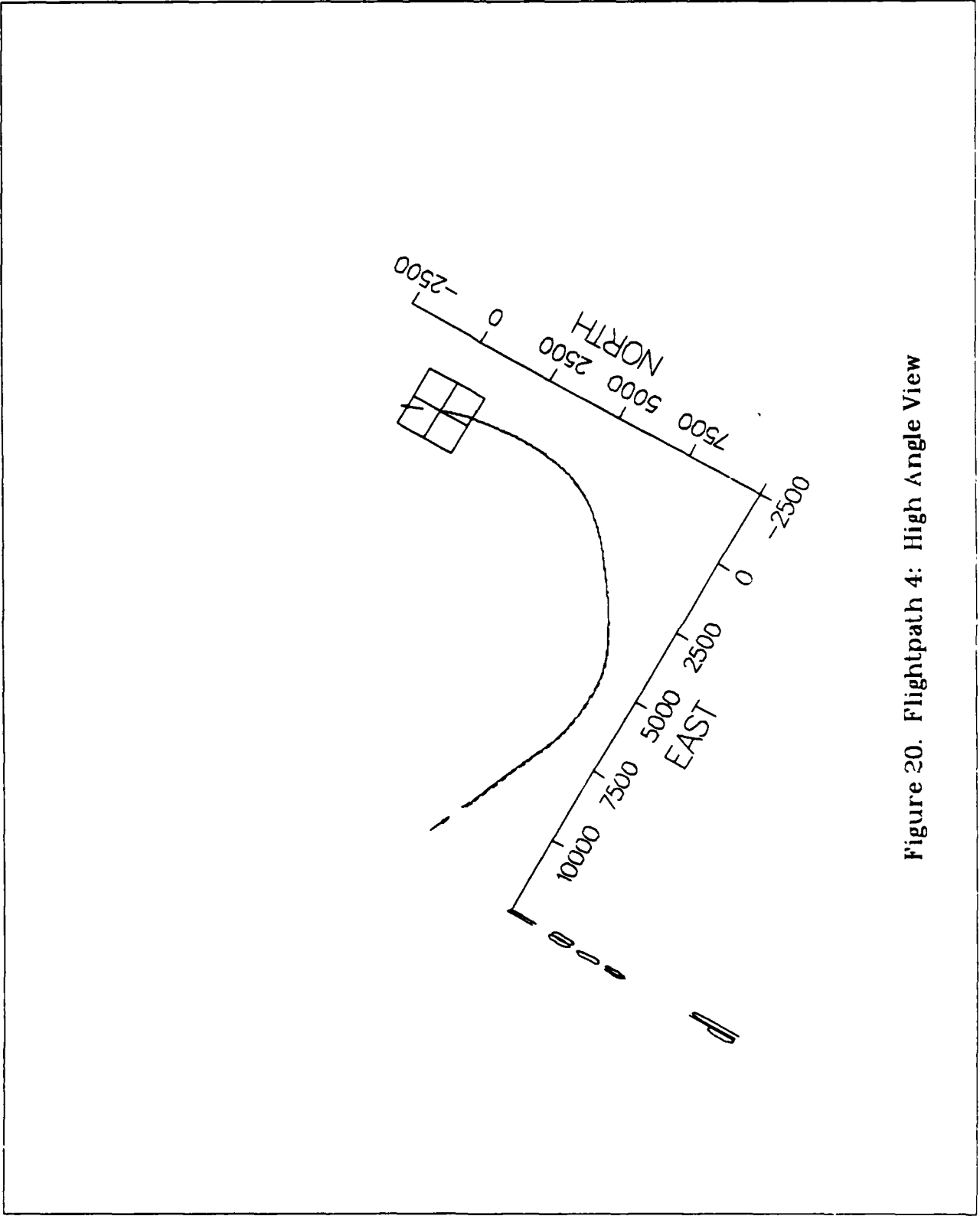

Figure 20. Flightpath 4: High Angle View

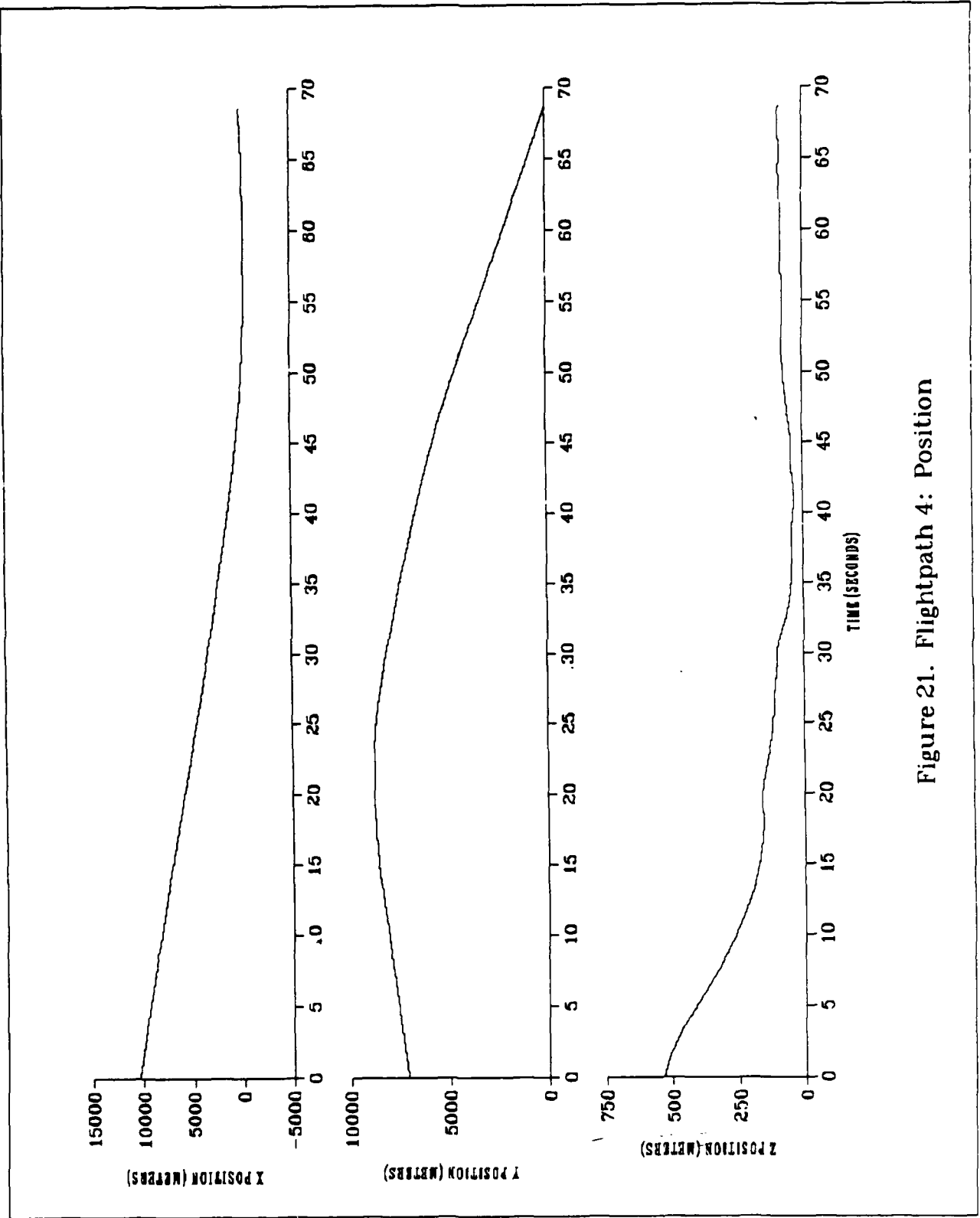

Figure 21. Flightpath 4: Position

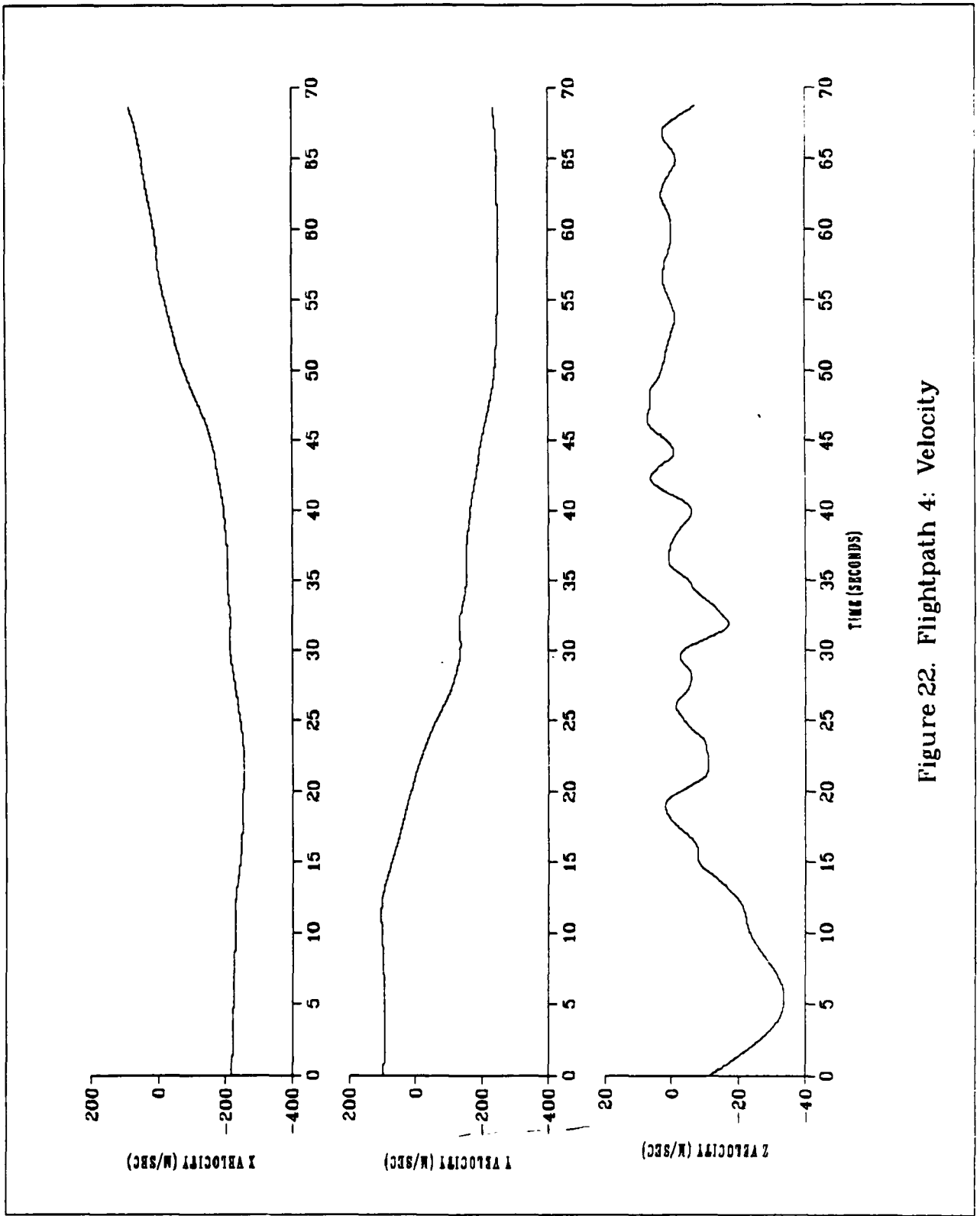

Figure 22. Flightpath 4: Velocity

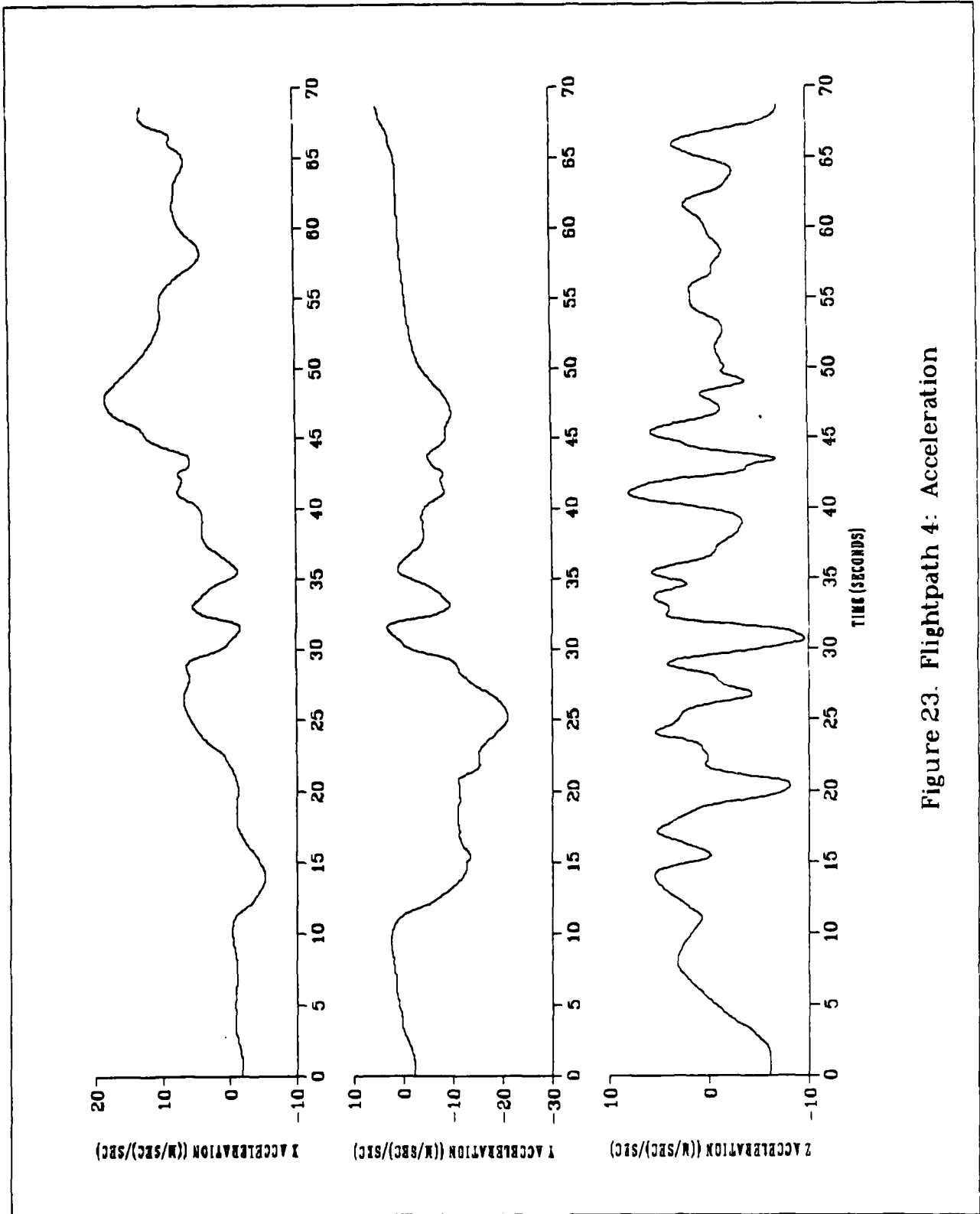

Figure 23. Flightpath 4: Acceleration

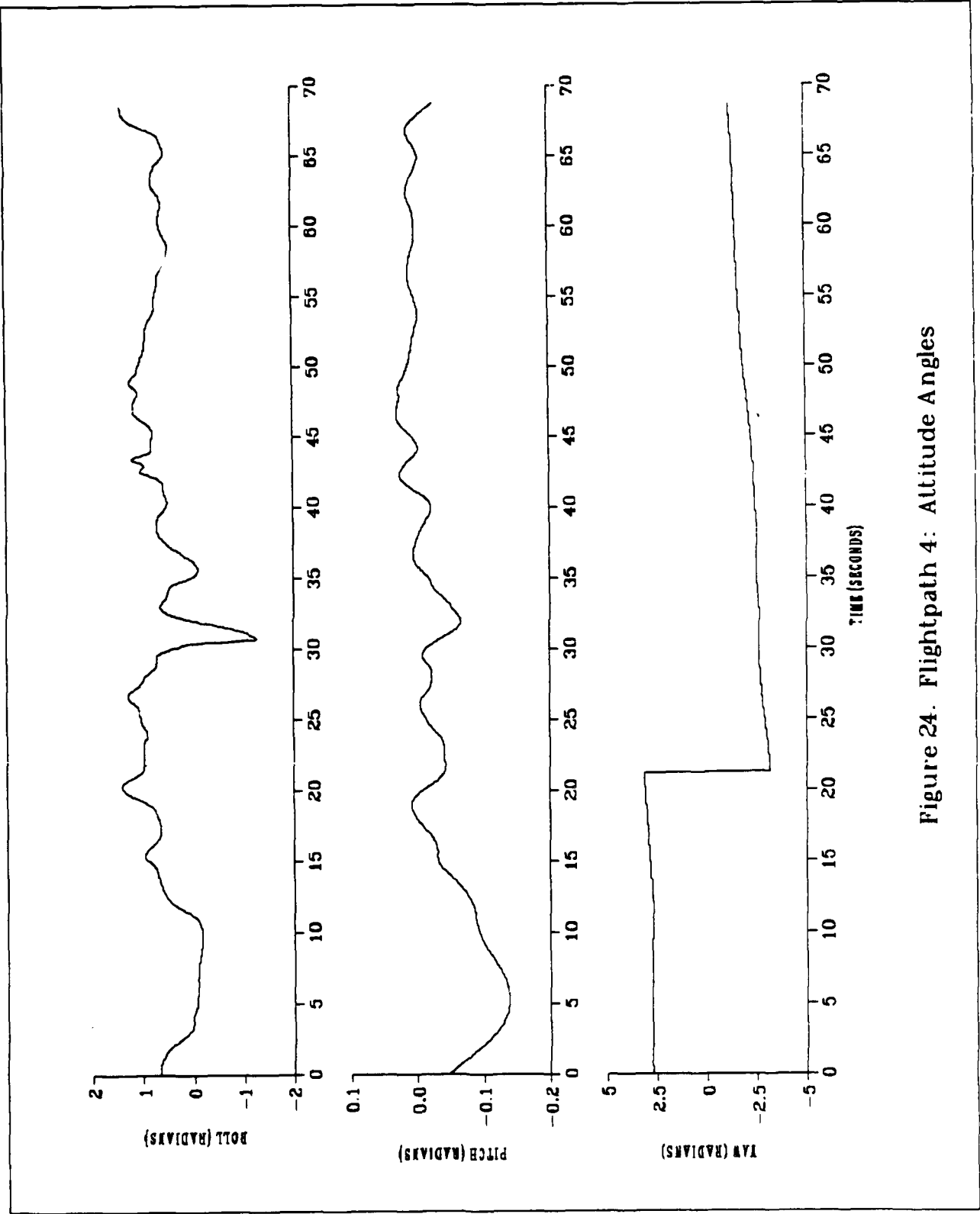

Figure 24. Flightpath 4: Attitude Angles

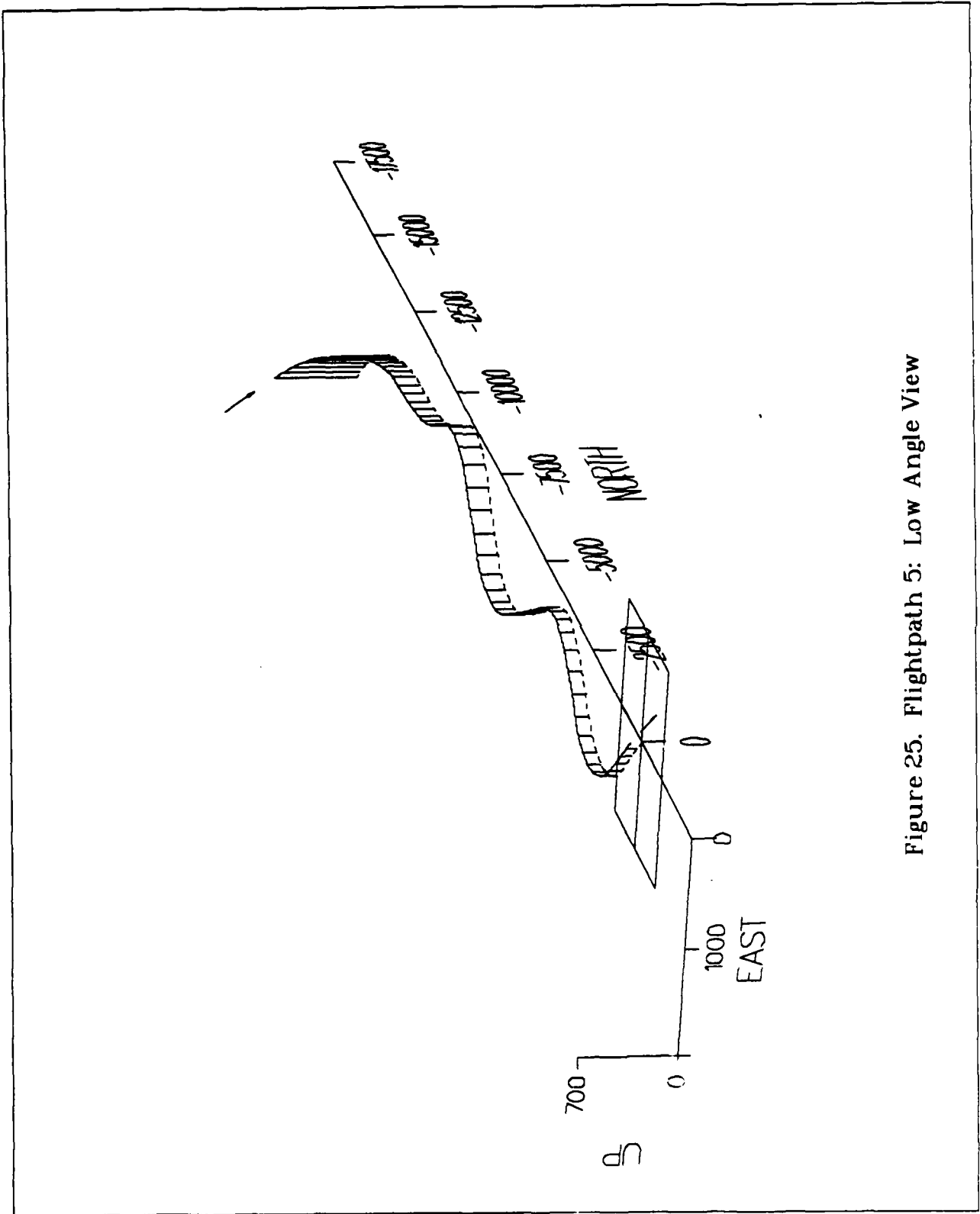

Figure 25. Flightpath 5: Low Angle View

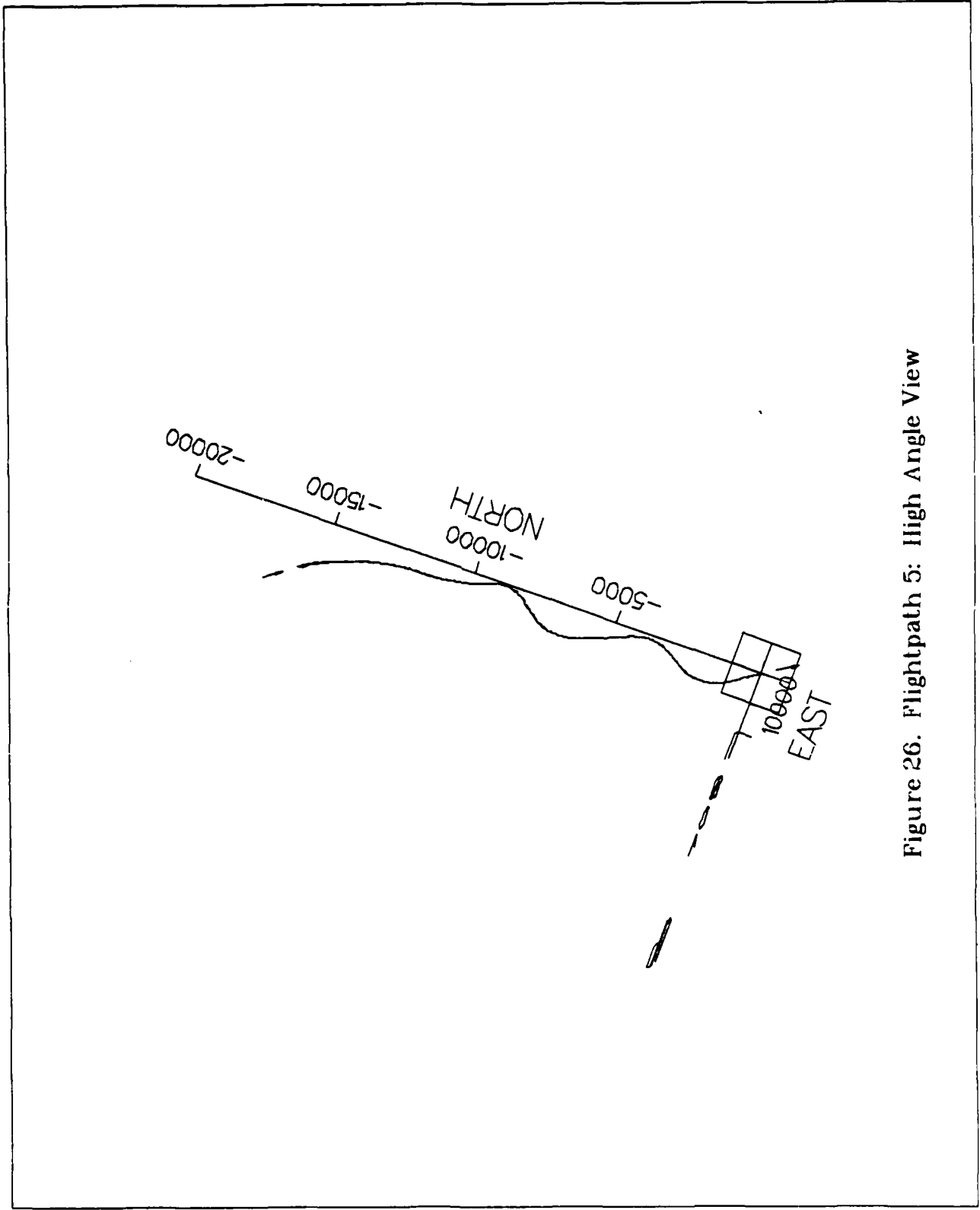

Figure 26. Flightpath 5: High Angle View

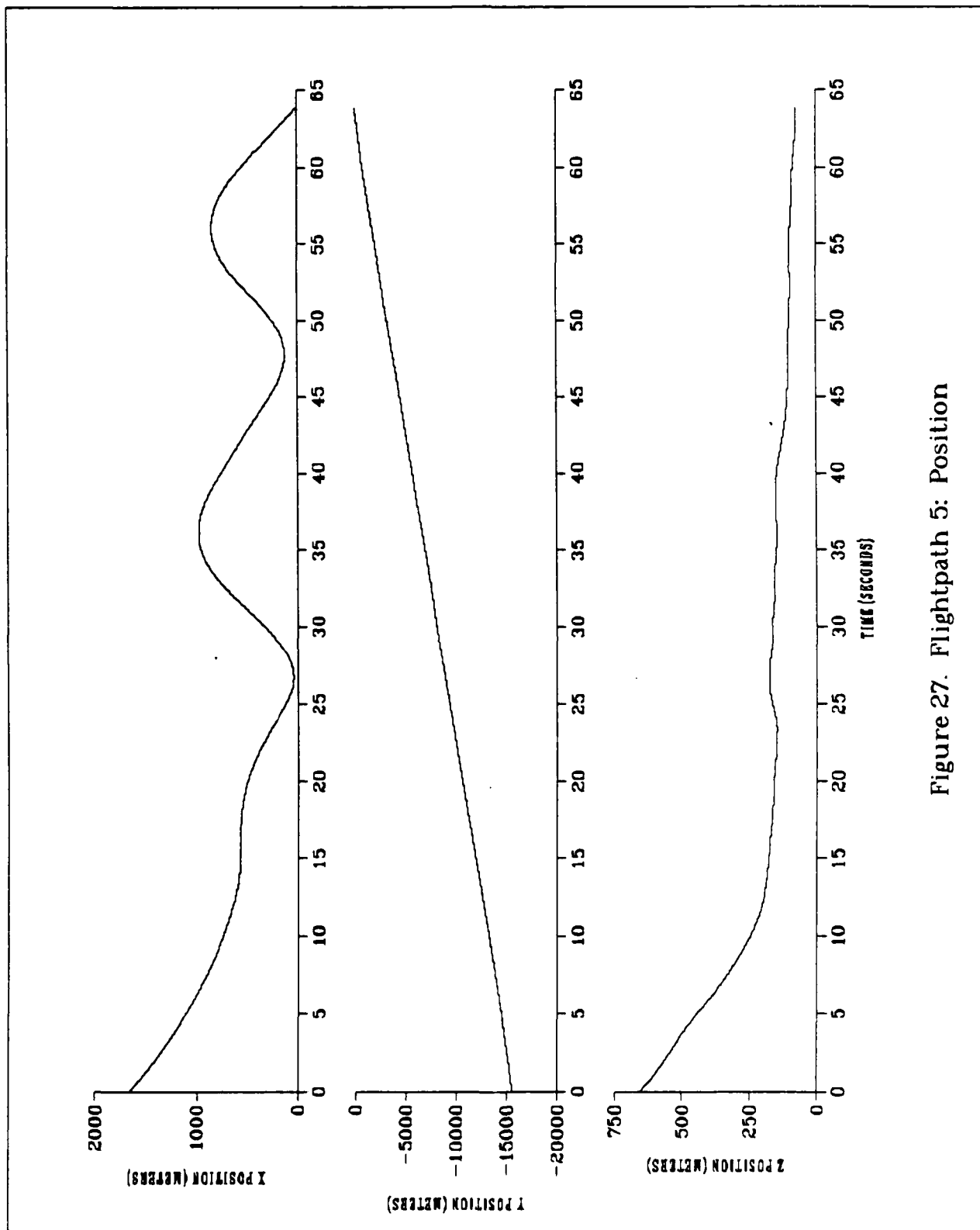

Figure 27. Flightpath 5: Position

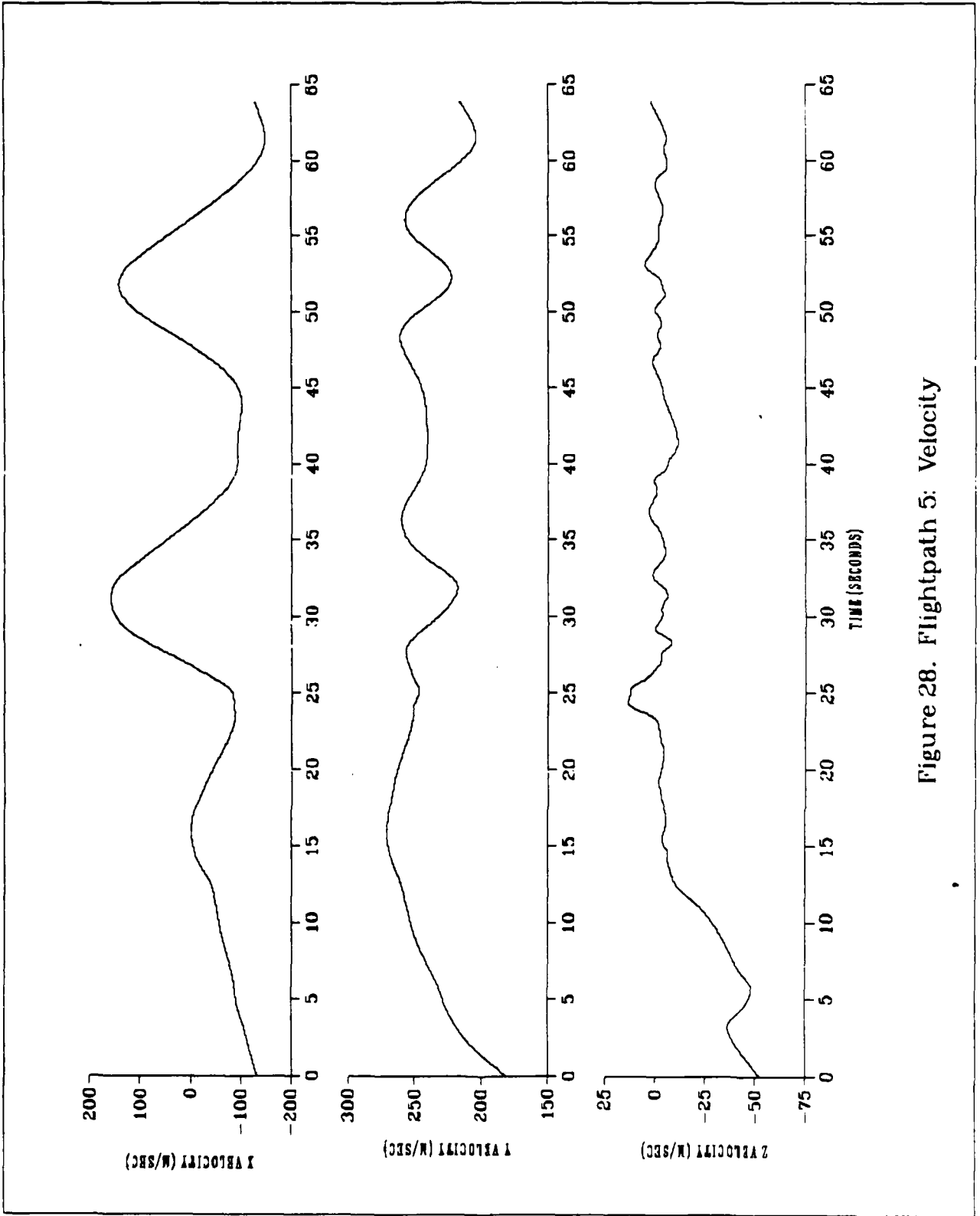

Figure 28. Flightpath 5: Velocity

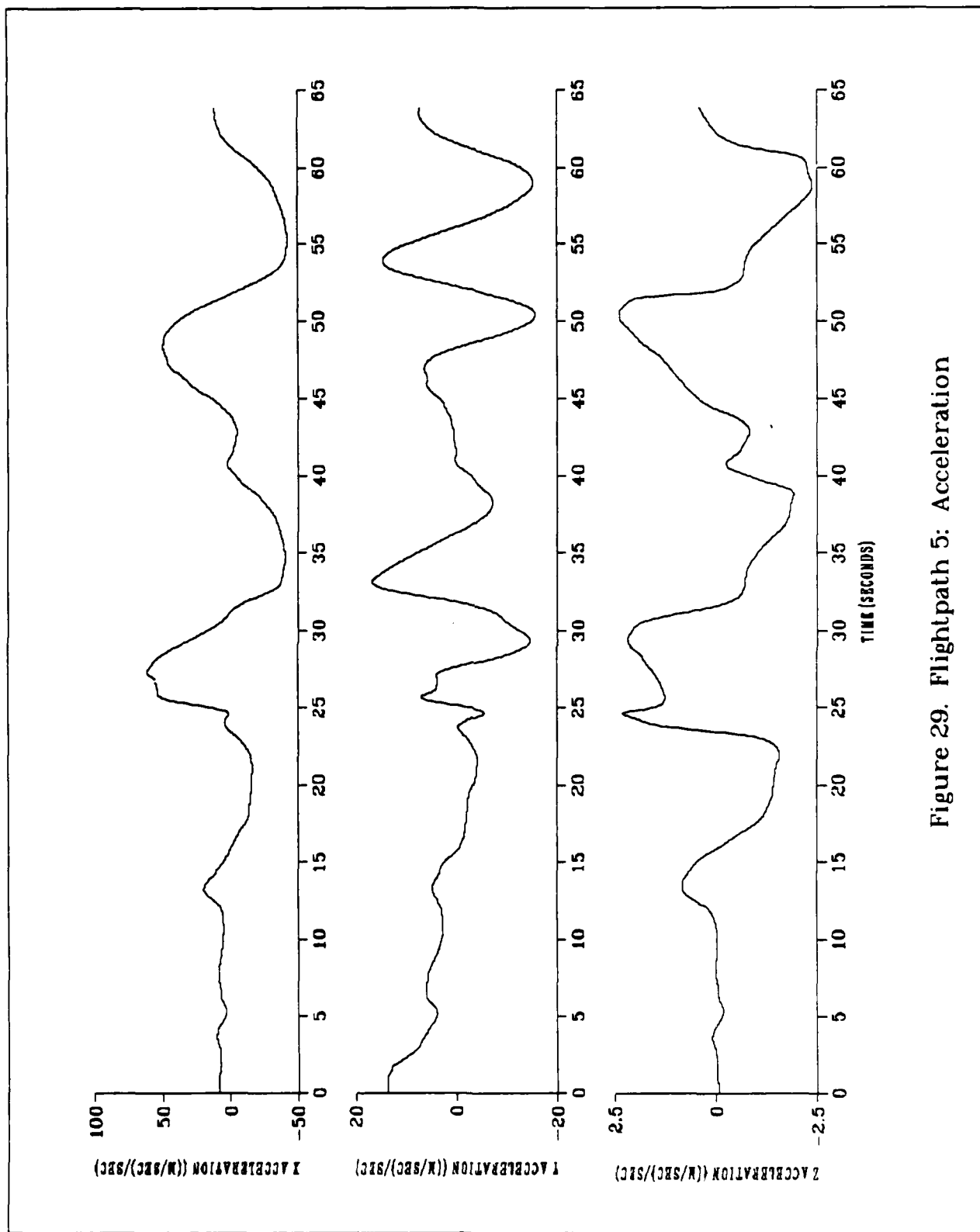

Figure 29. Flightpath 5: Acceleration

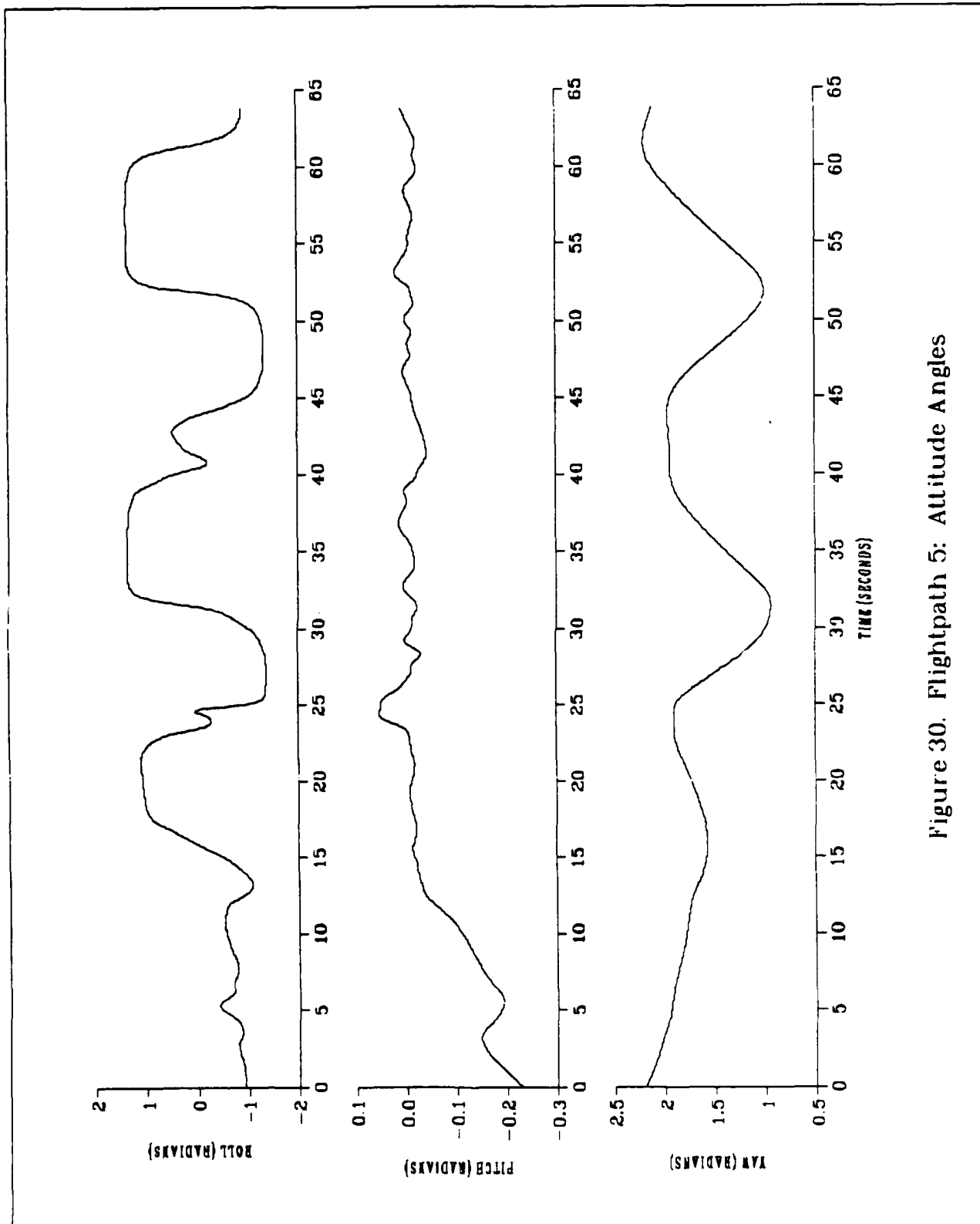

Figure 30. Flightpath 5: Attitude Angles

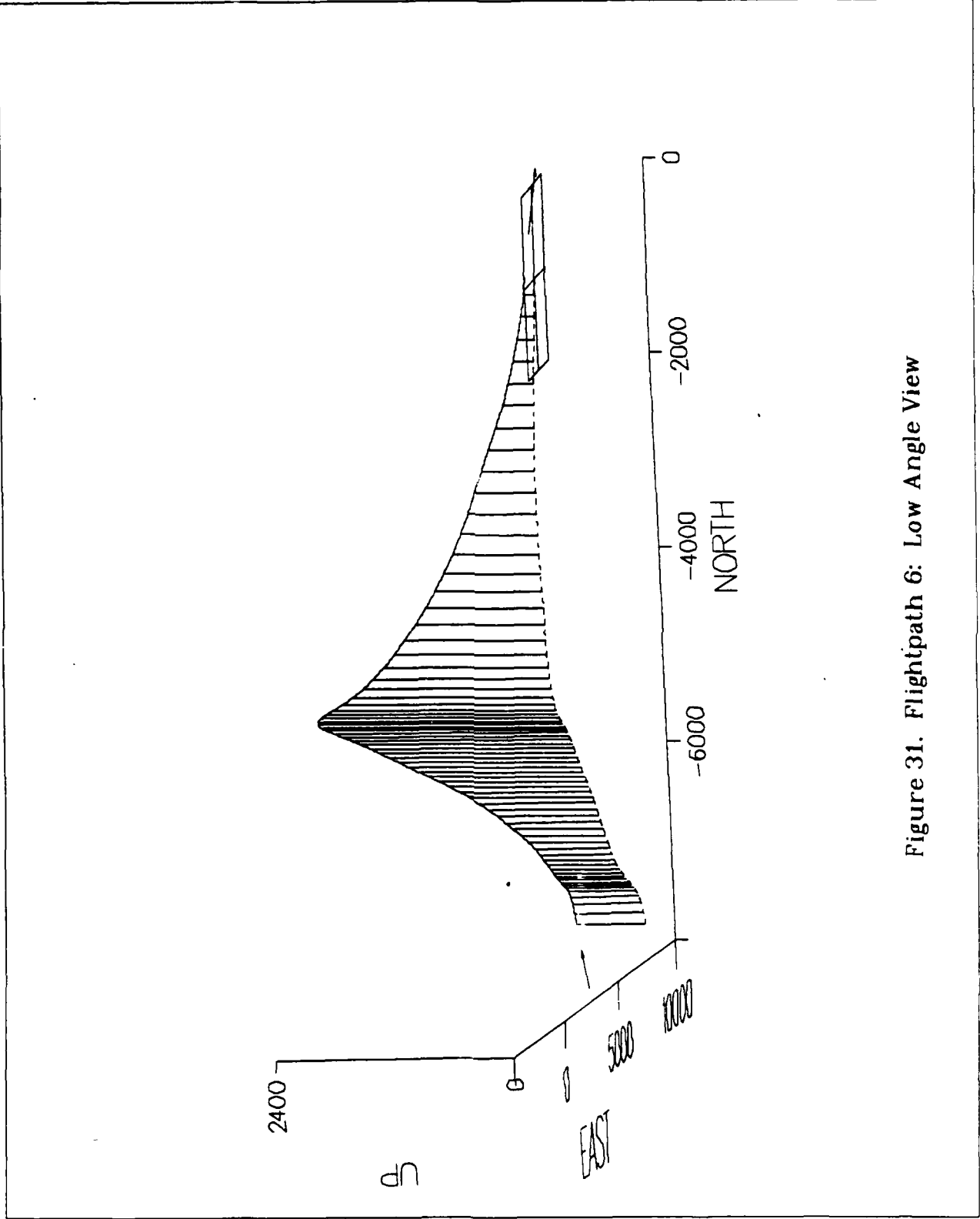

Figure 31. Flightpath 6: Low Angle View

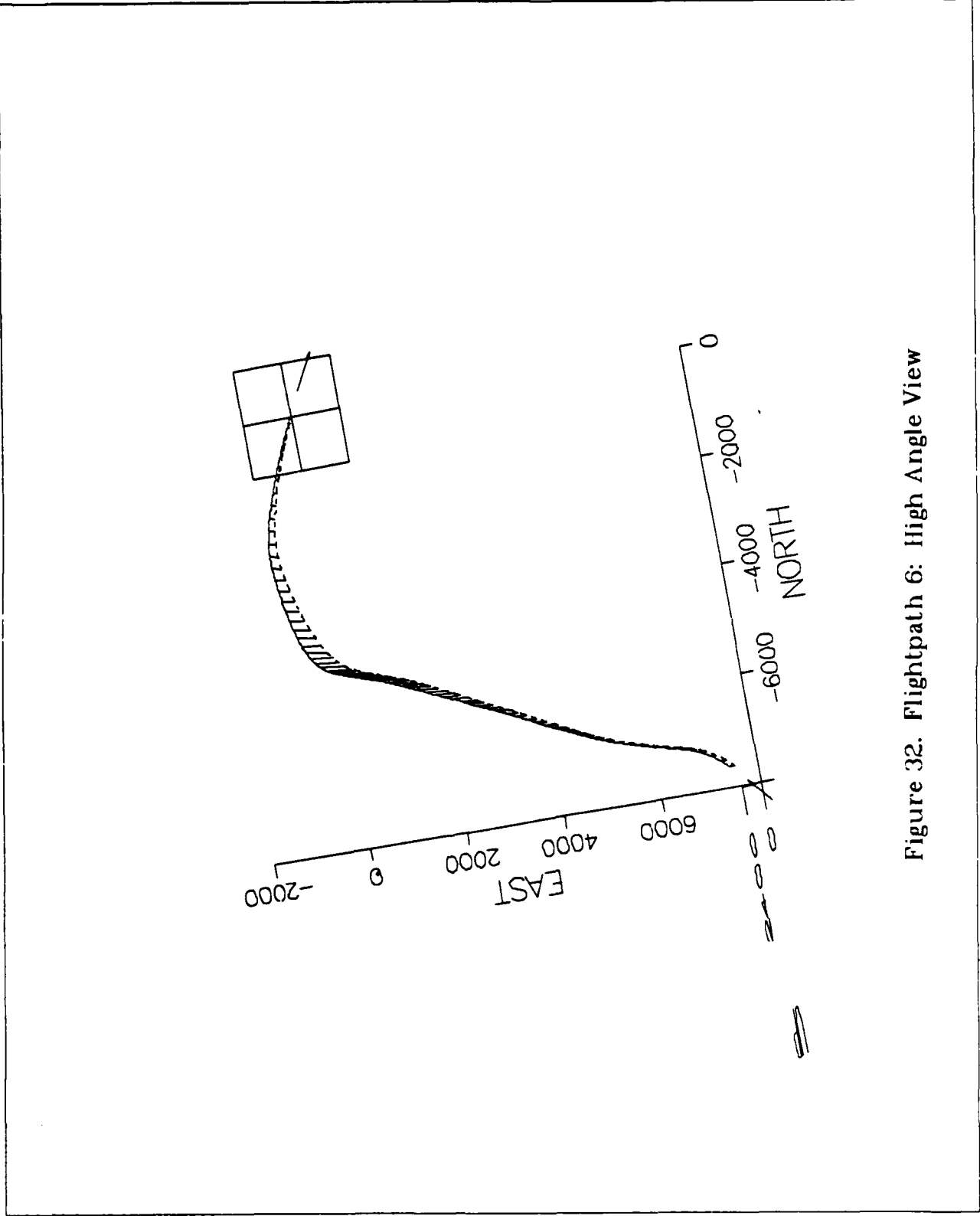

Figure 32. Flightpath 6: High Angle View

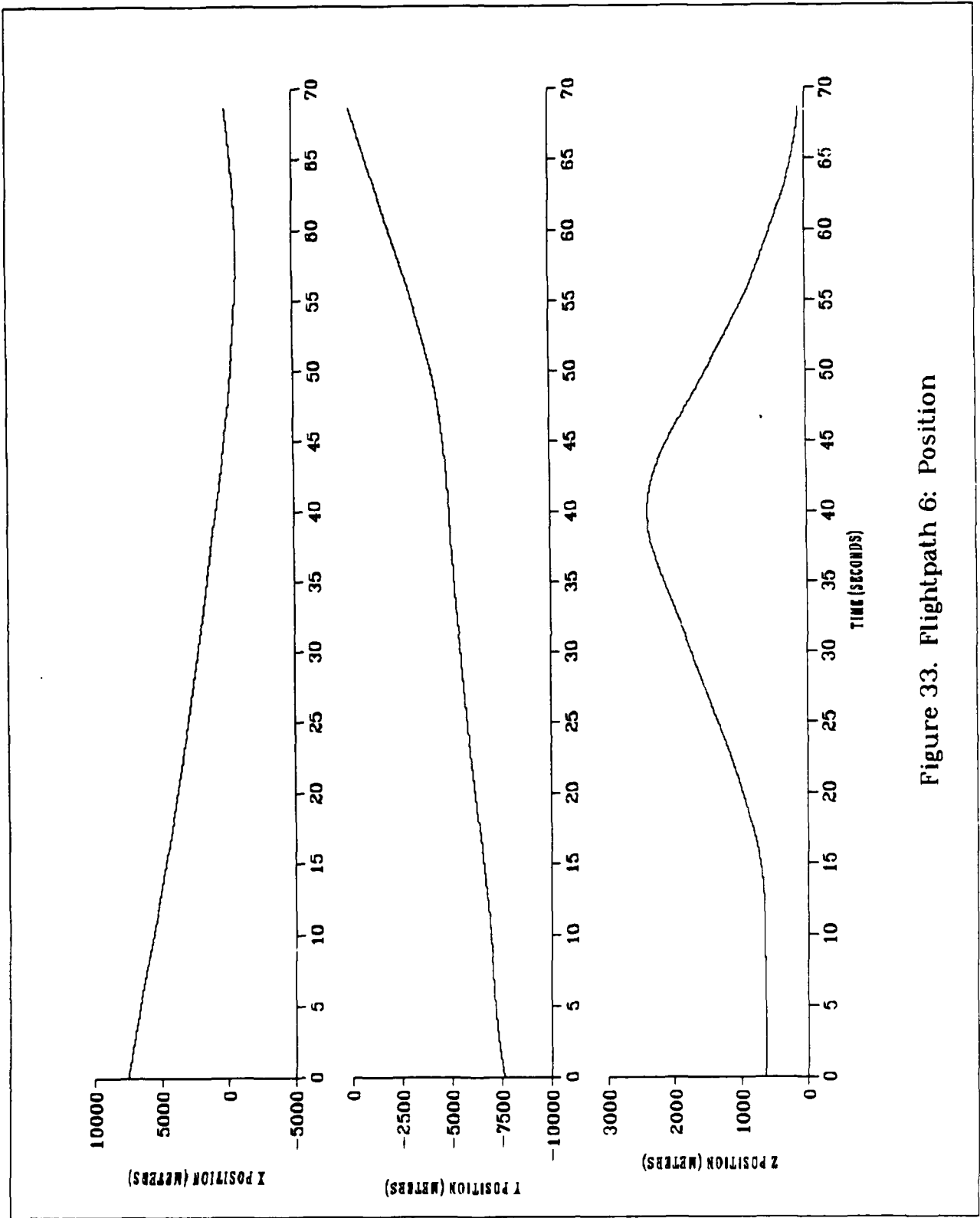

Figure 33. Flightpath 6: Position

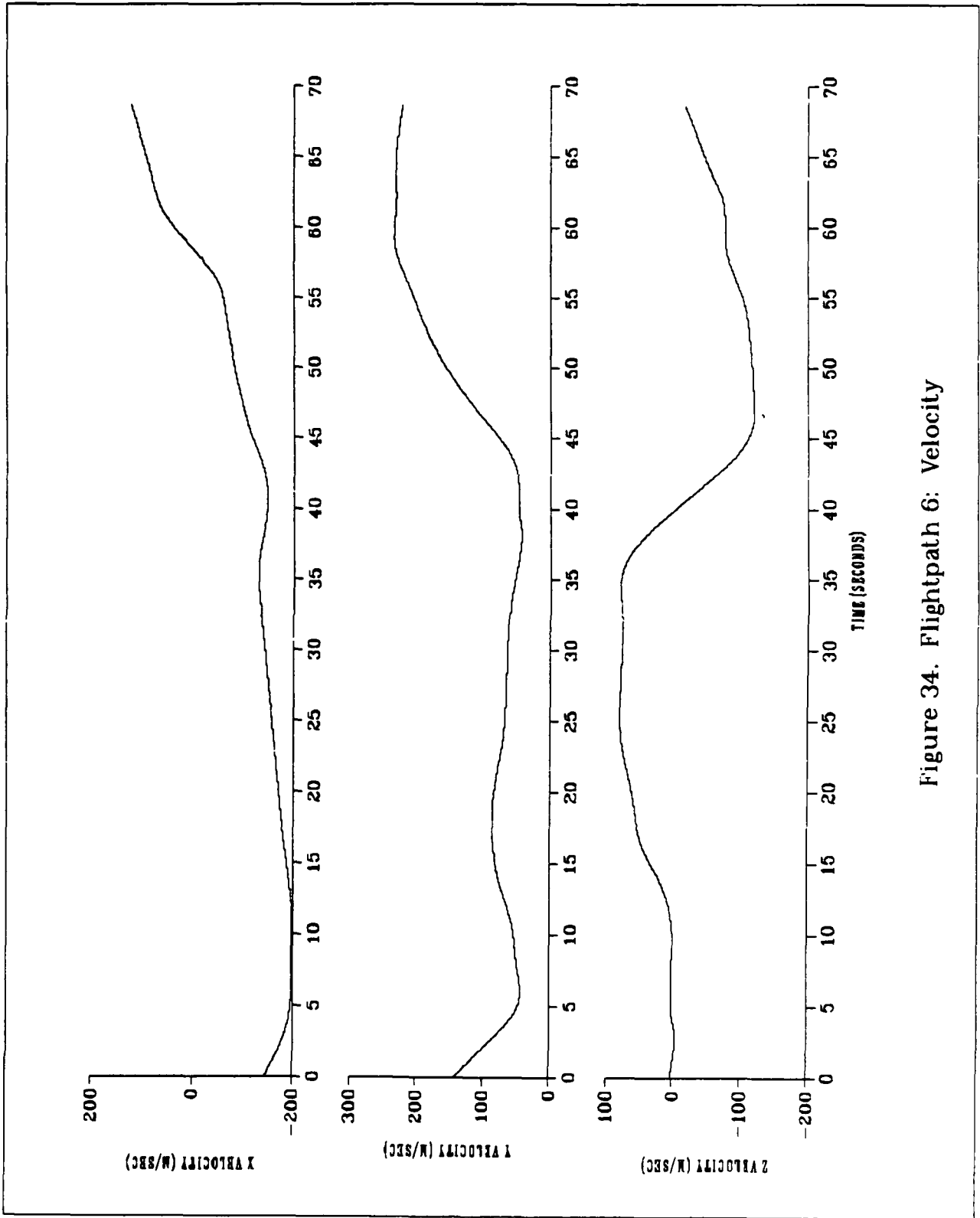

Figure 34. Flightpath 6: Velocity

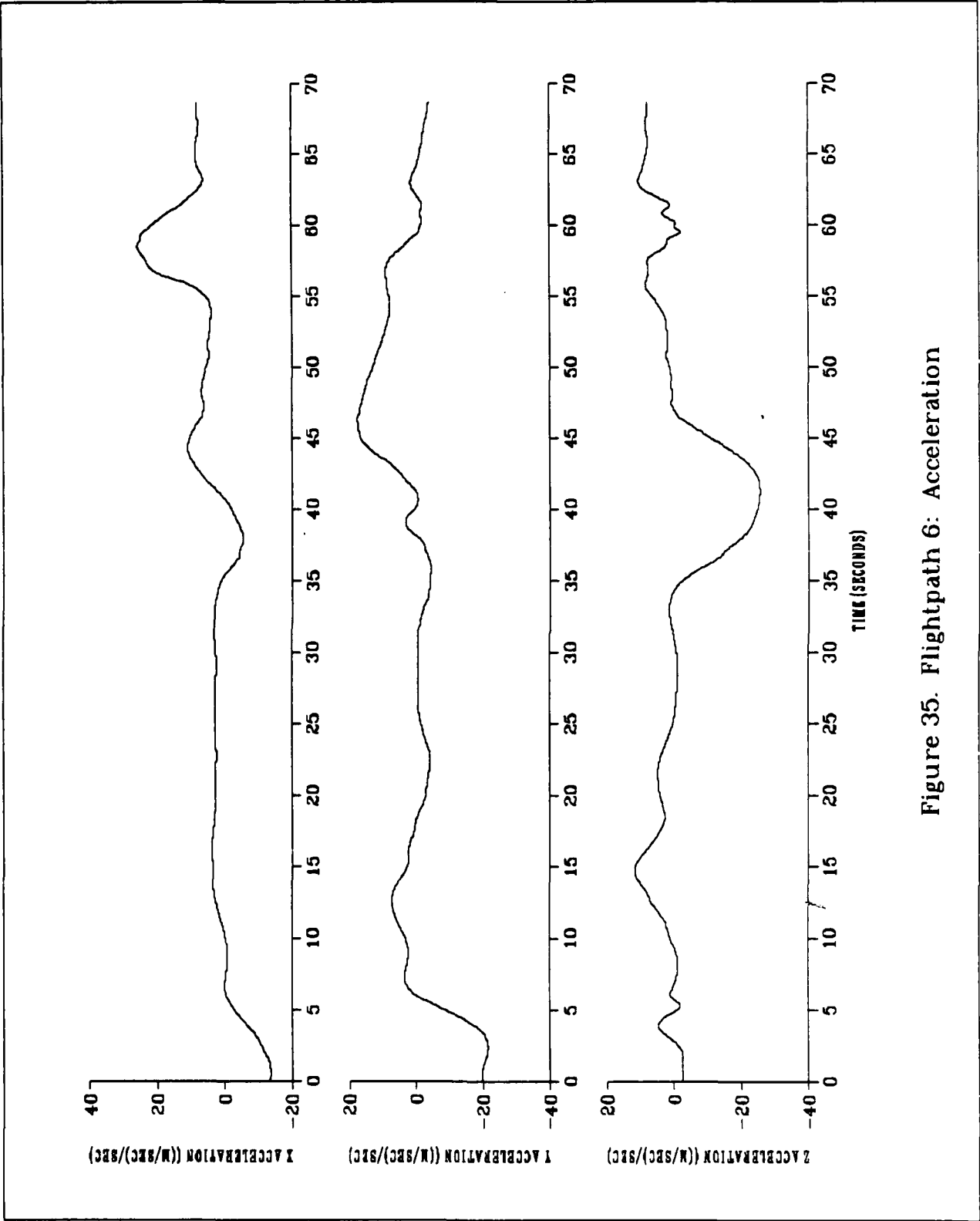

Figure 35. Flightpath 6: Acceleration

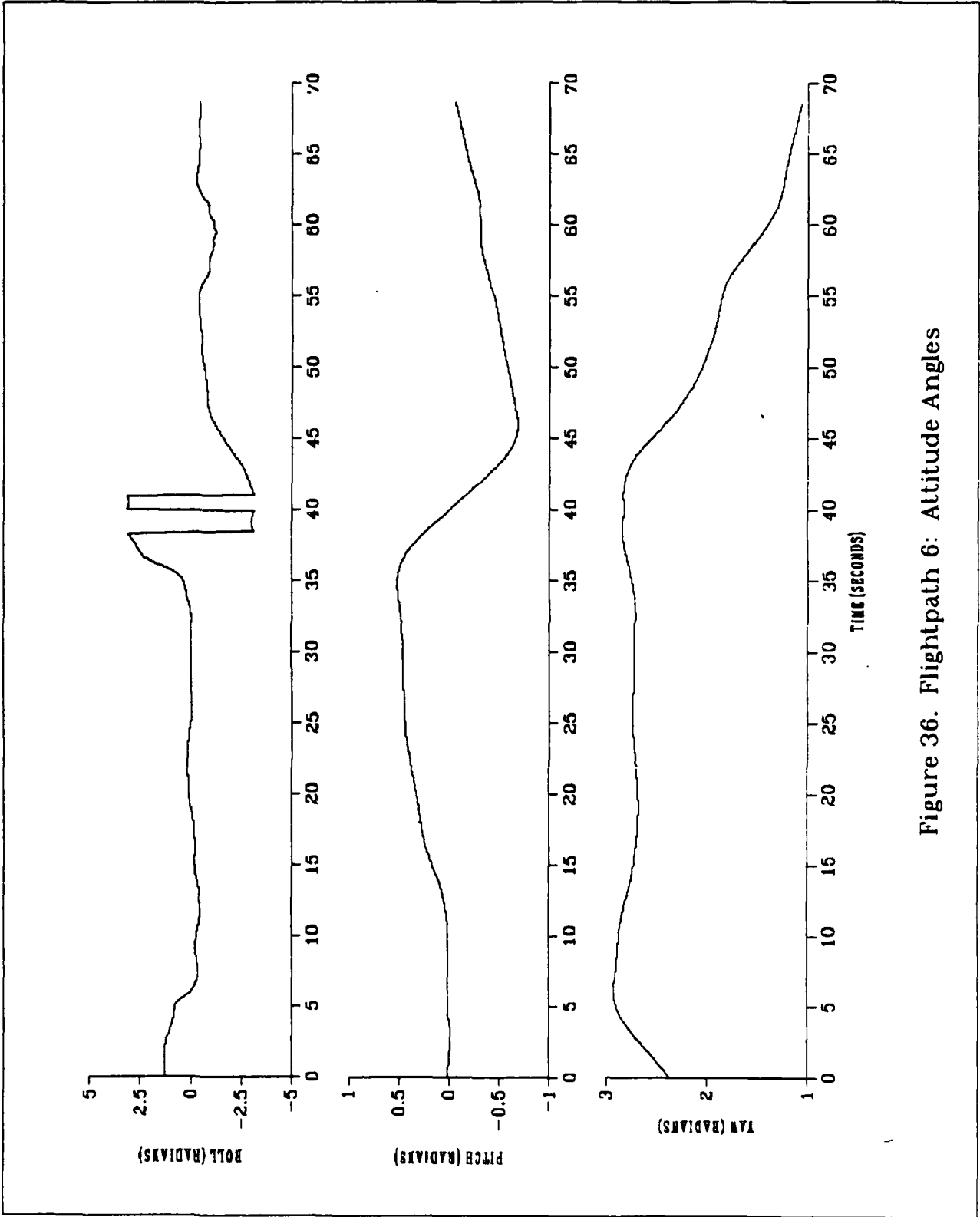

Figure 36. Flightpath 6: Altitude Angles

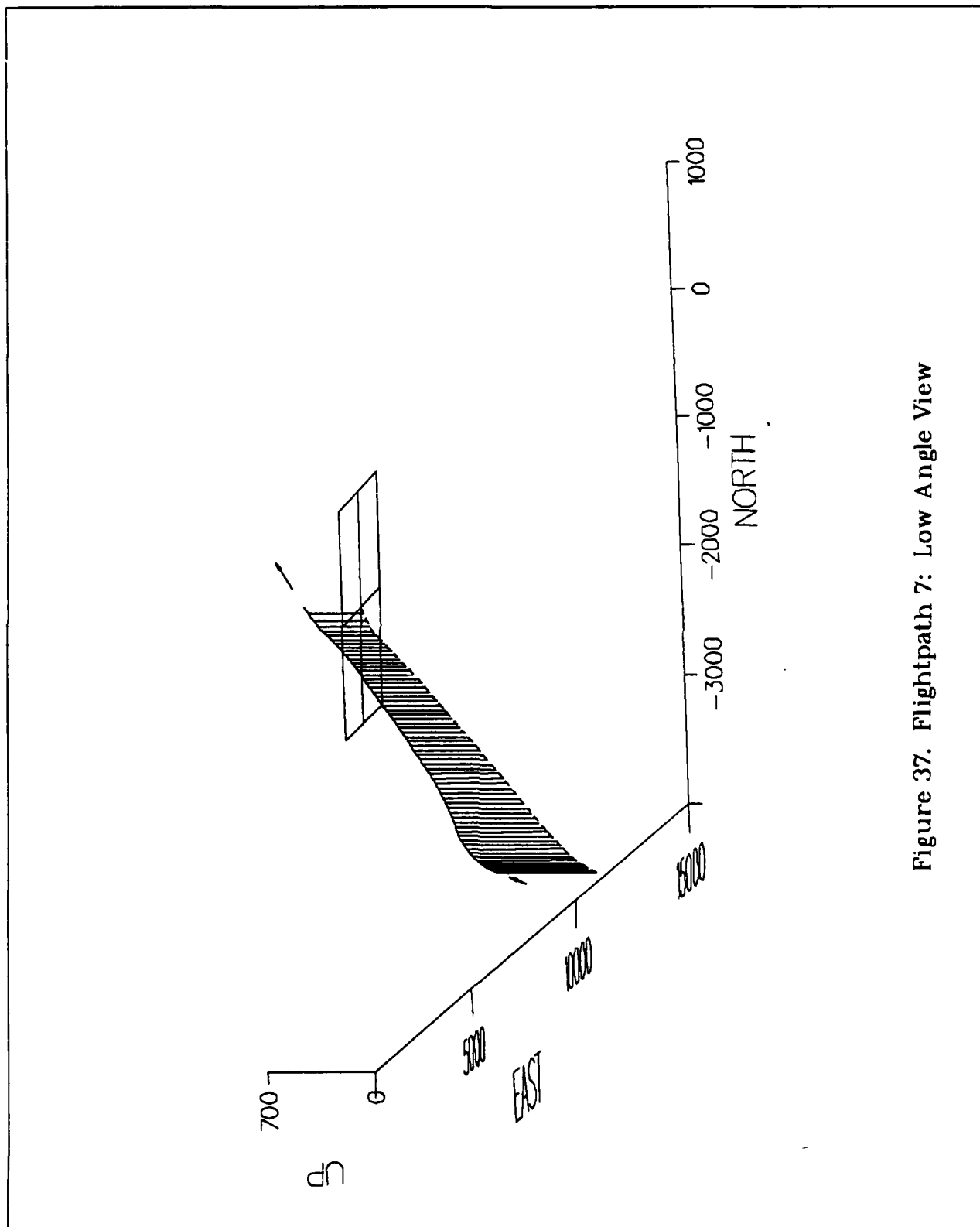

Figure 37. Flightpath 7: Low Angle View

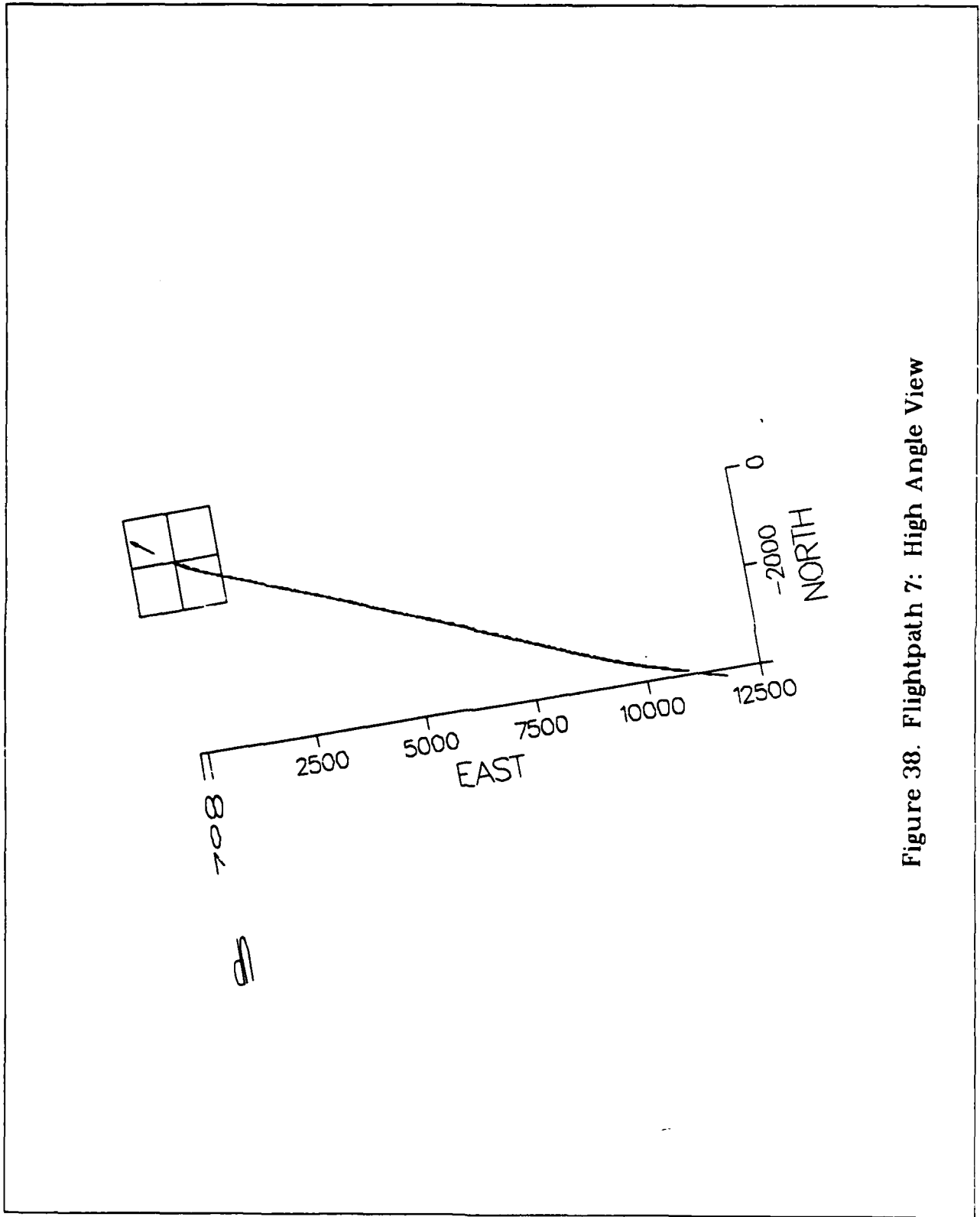

Figure 38. Flightpath 7: High Angle View

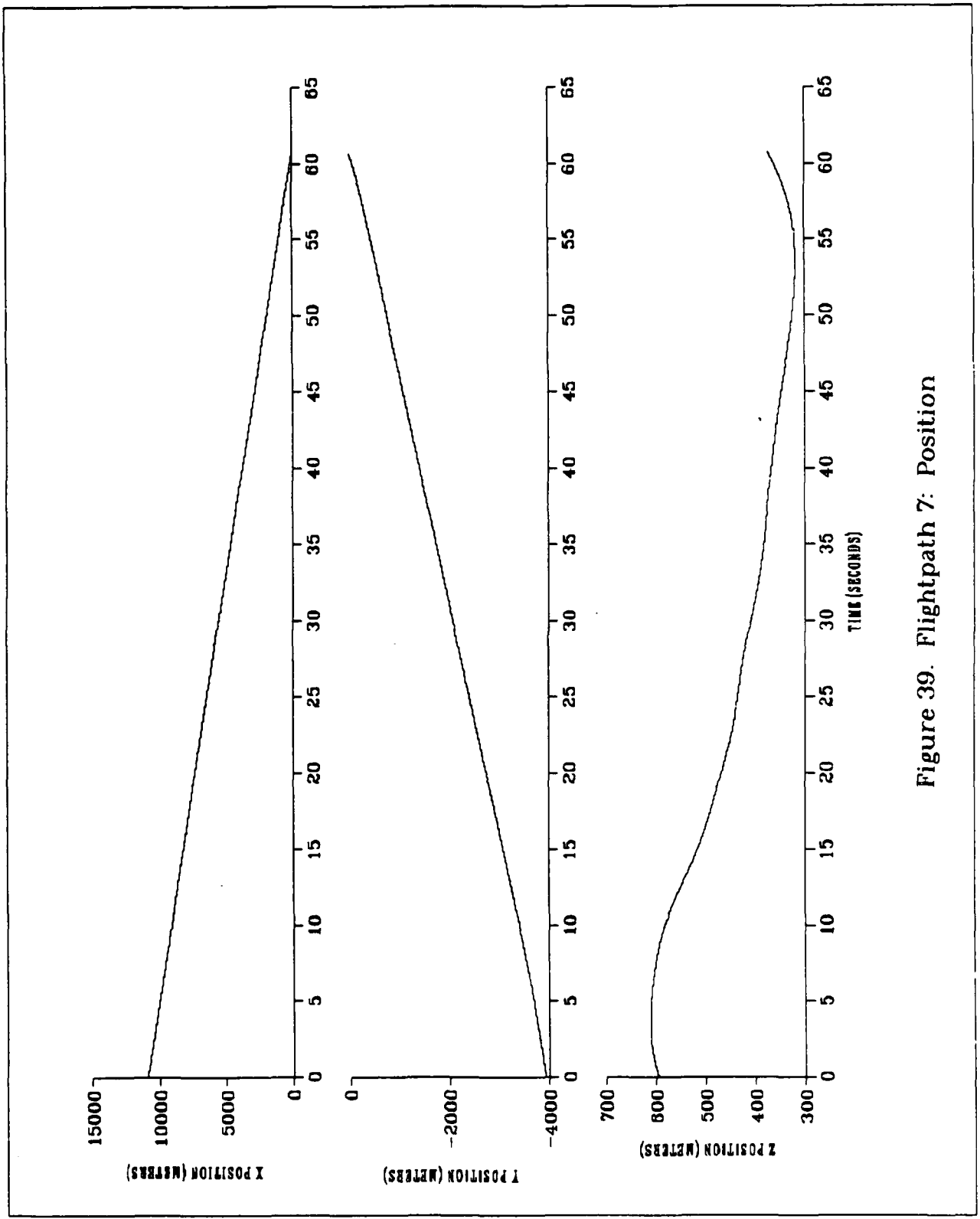

Figure 39. Flightpath 7: Position

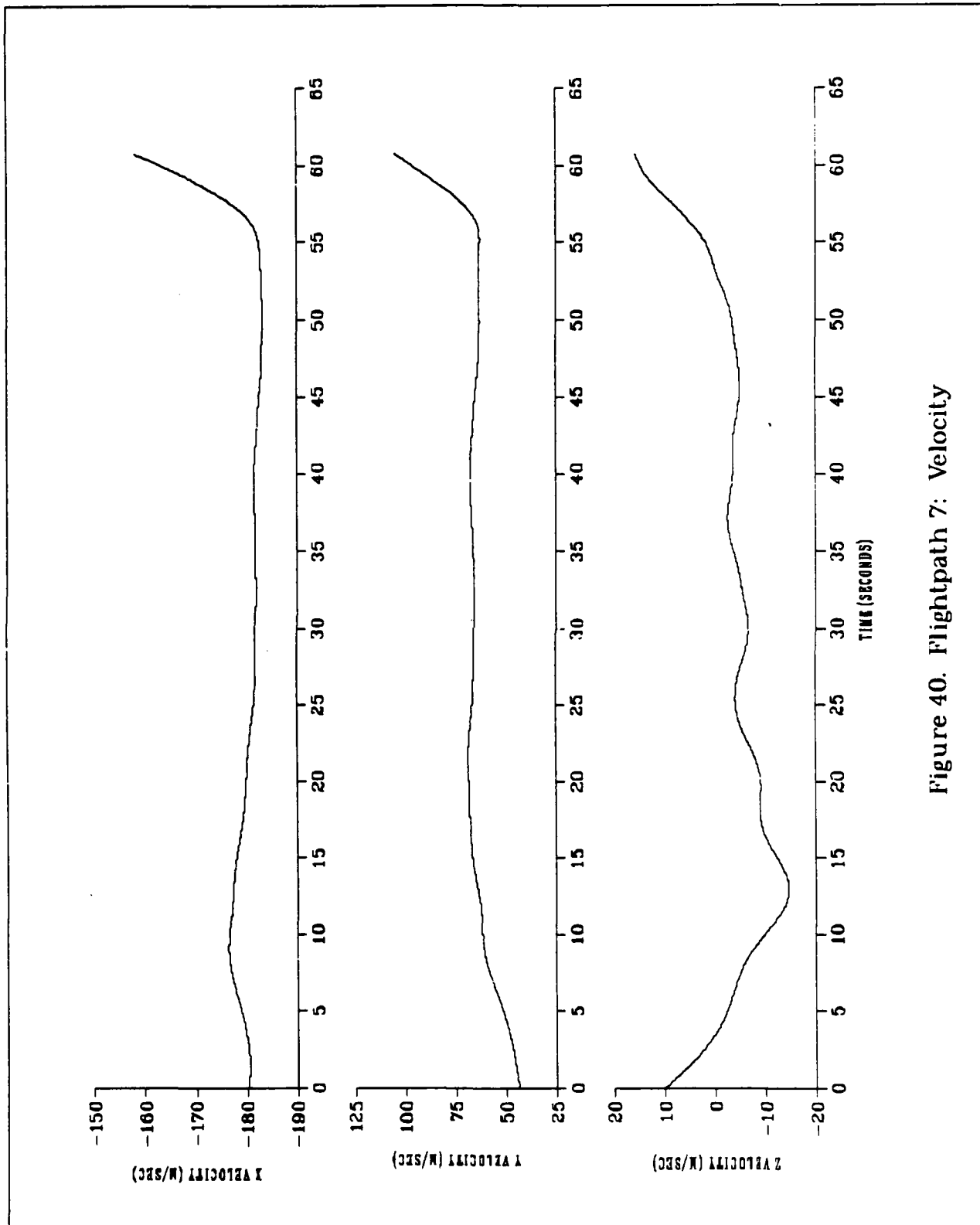

Figure 40. Flightpath 7: Velocity

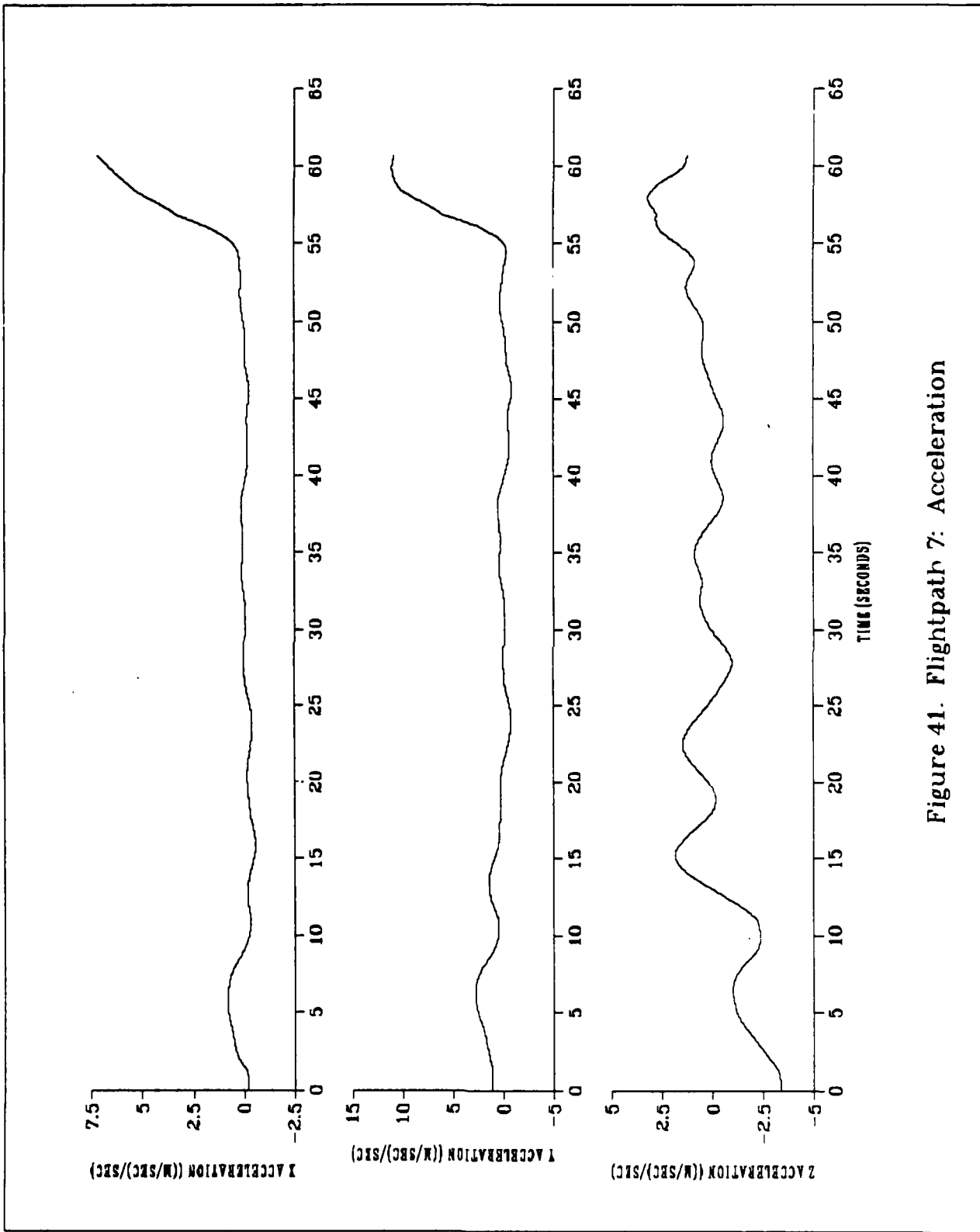

Figure 41. Flightpath 7: Acceleration

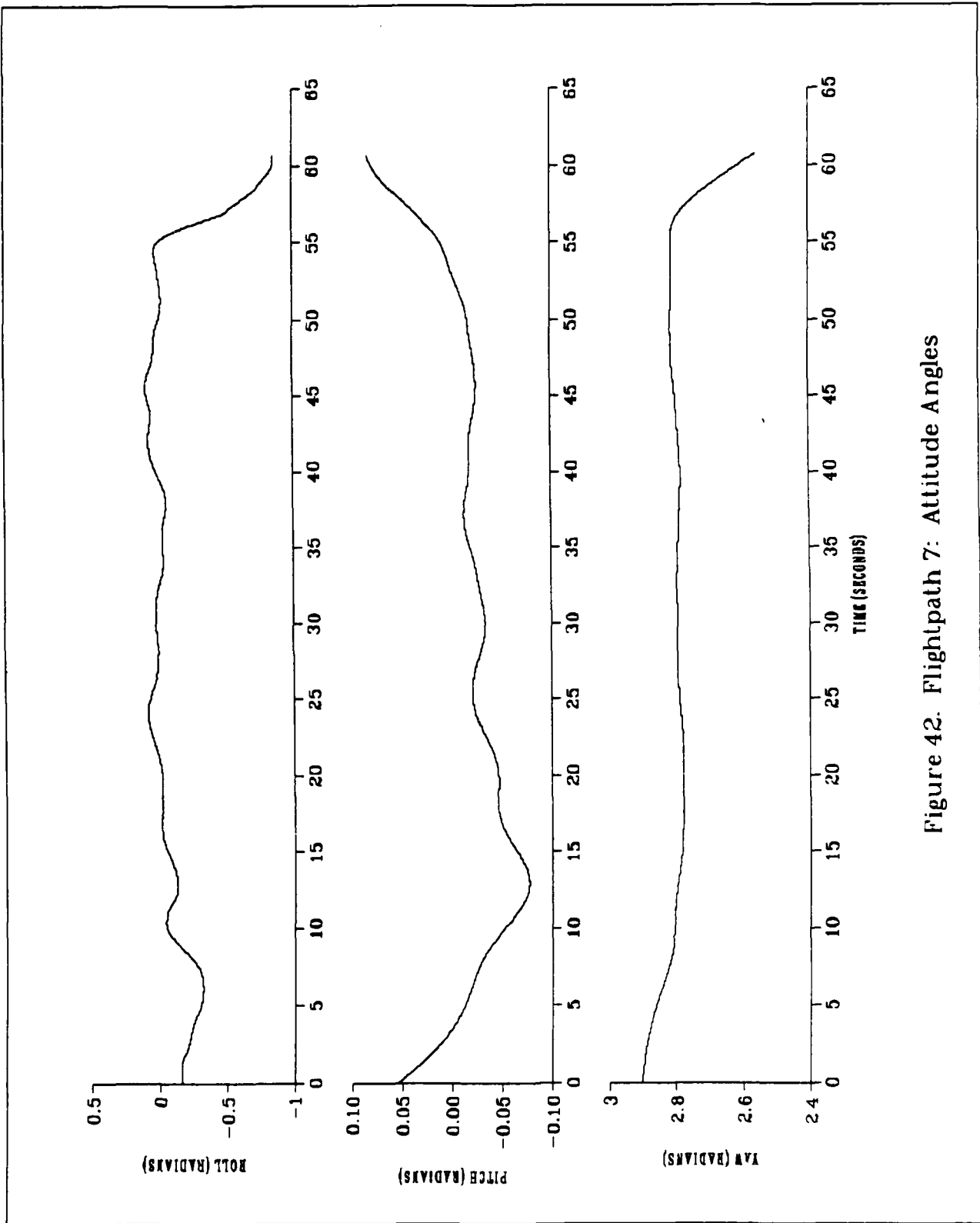

Figure 42. Flightpath 7: Attitude Angles

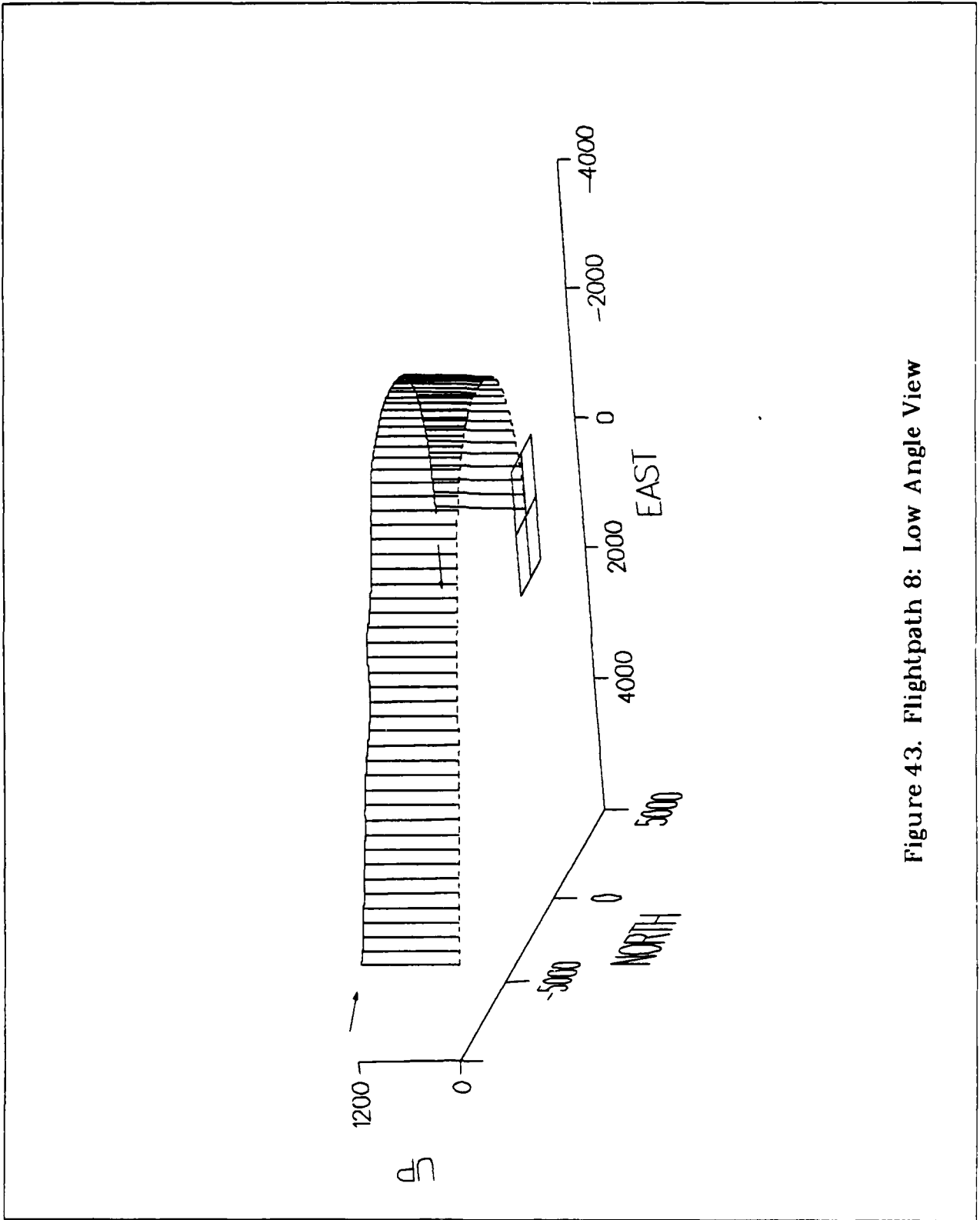

Figure 43. Flightpath 8: Low Angle View

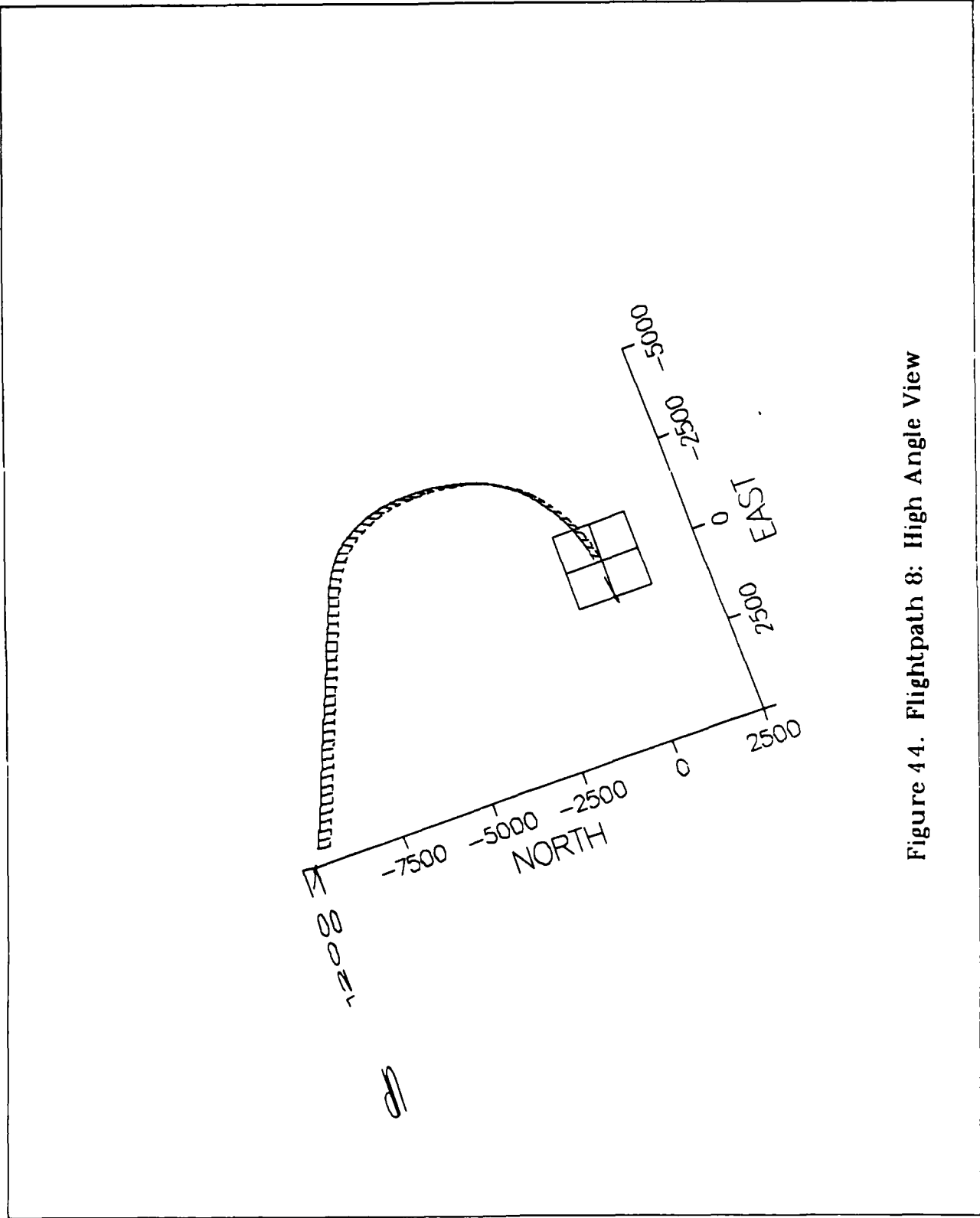

Figure 44. Flightpath 8: High Angle View

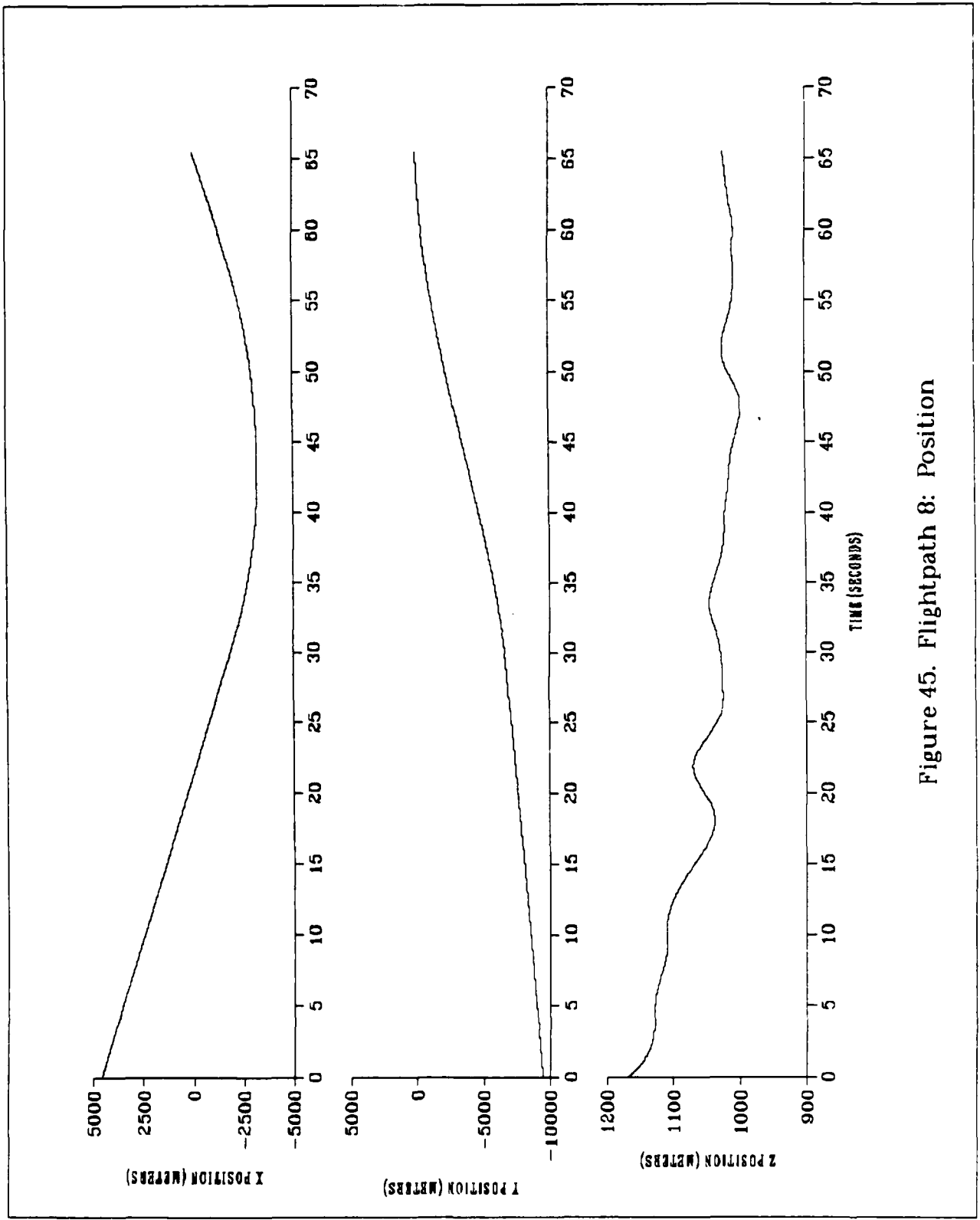

Figure 45. Flightpath 8: Position

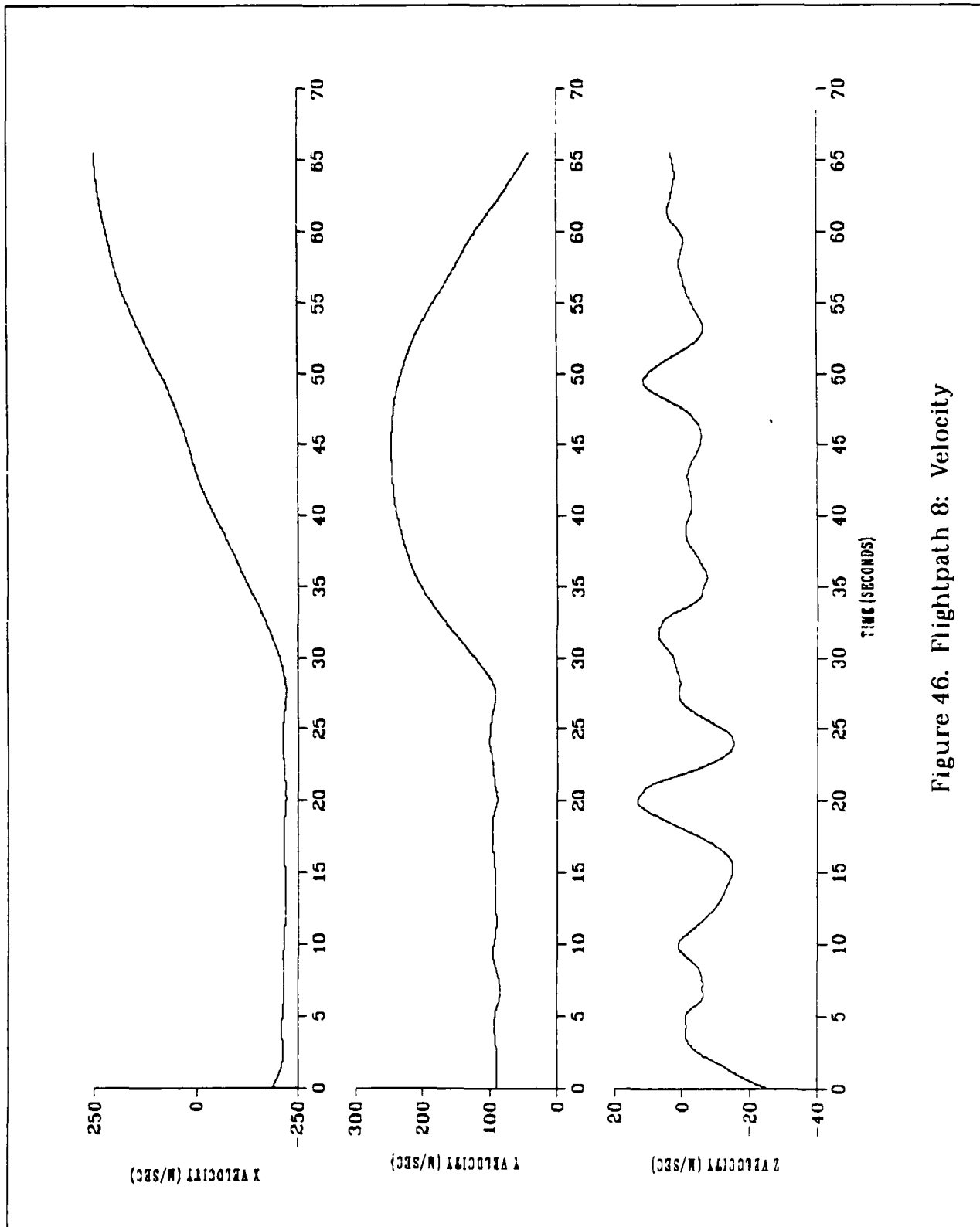

Figure 46. Flightpath 8: Velocity

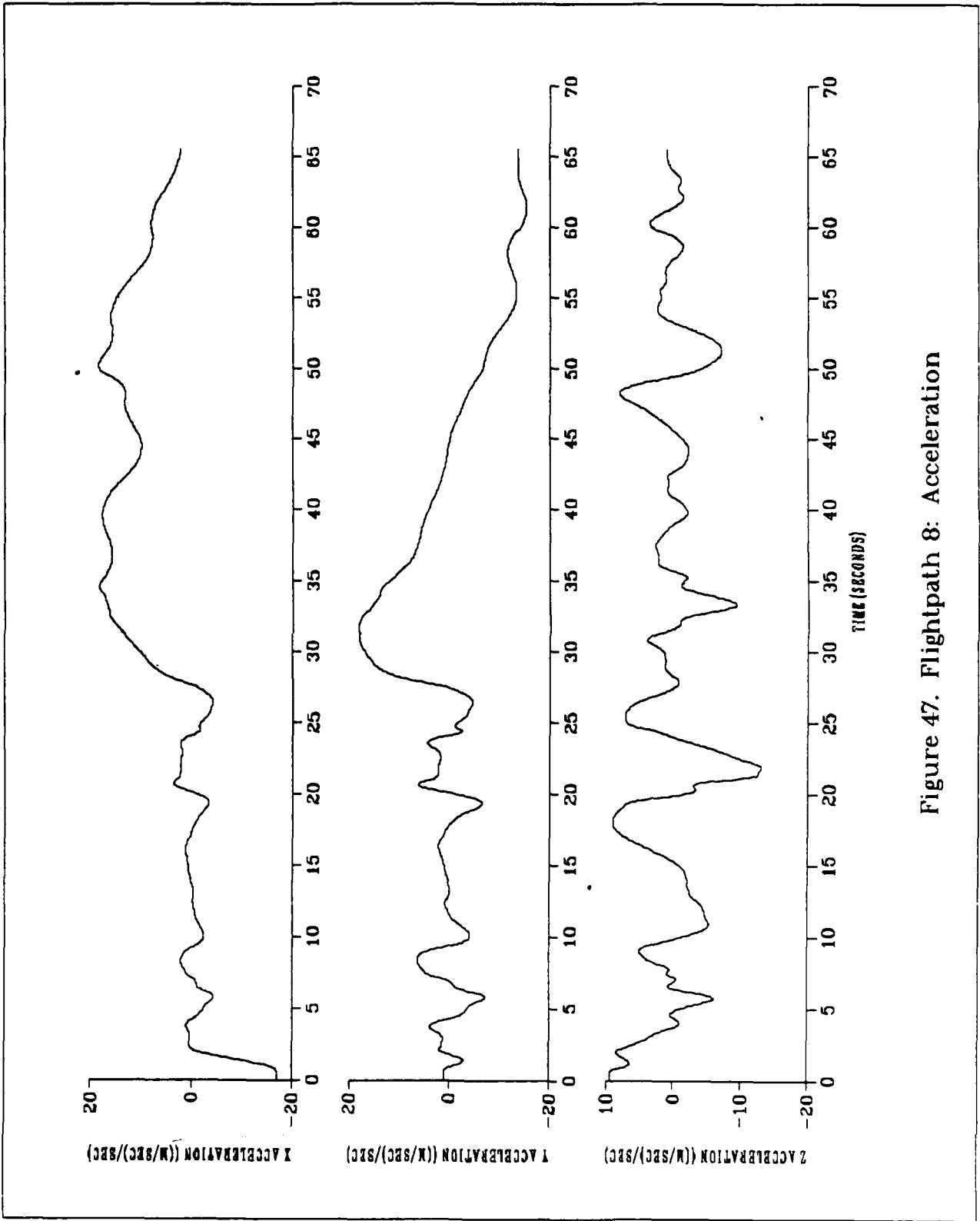

Figure 47. Flightpath 8: Acceleration

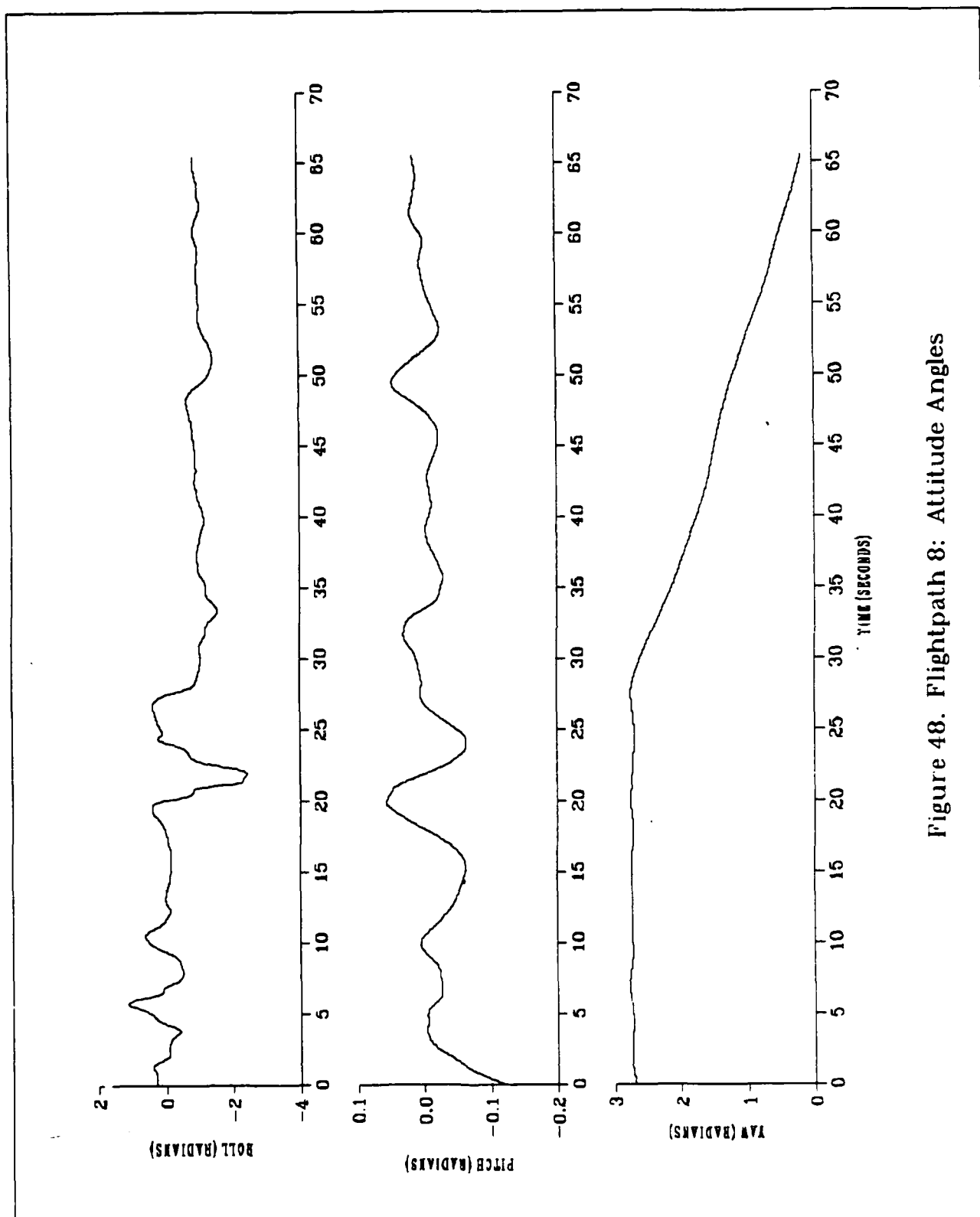

Figure 48. Flightpath 8: Attitude Angles

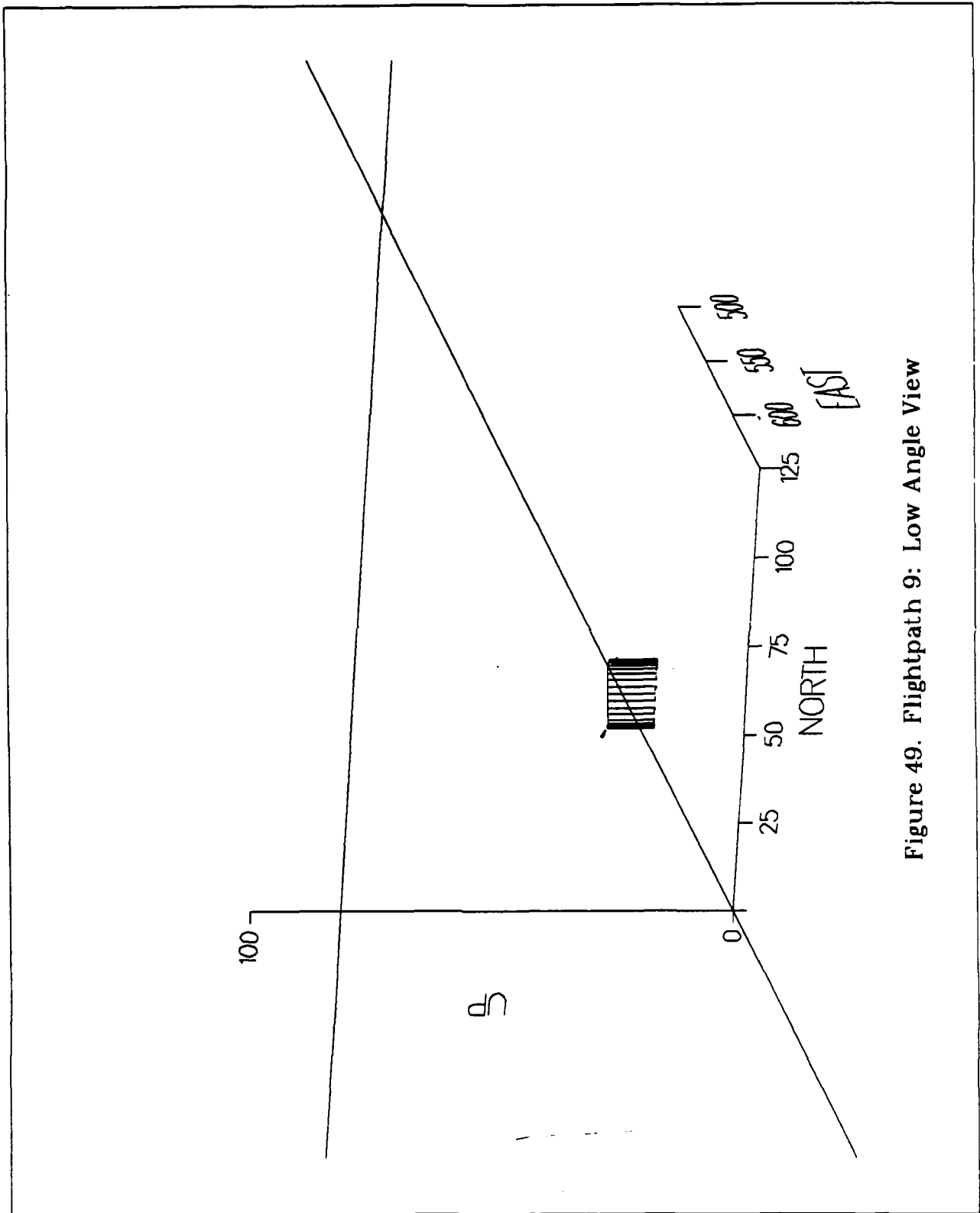

Figure 49. Flightpath 9: Low Angle View

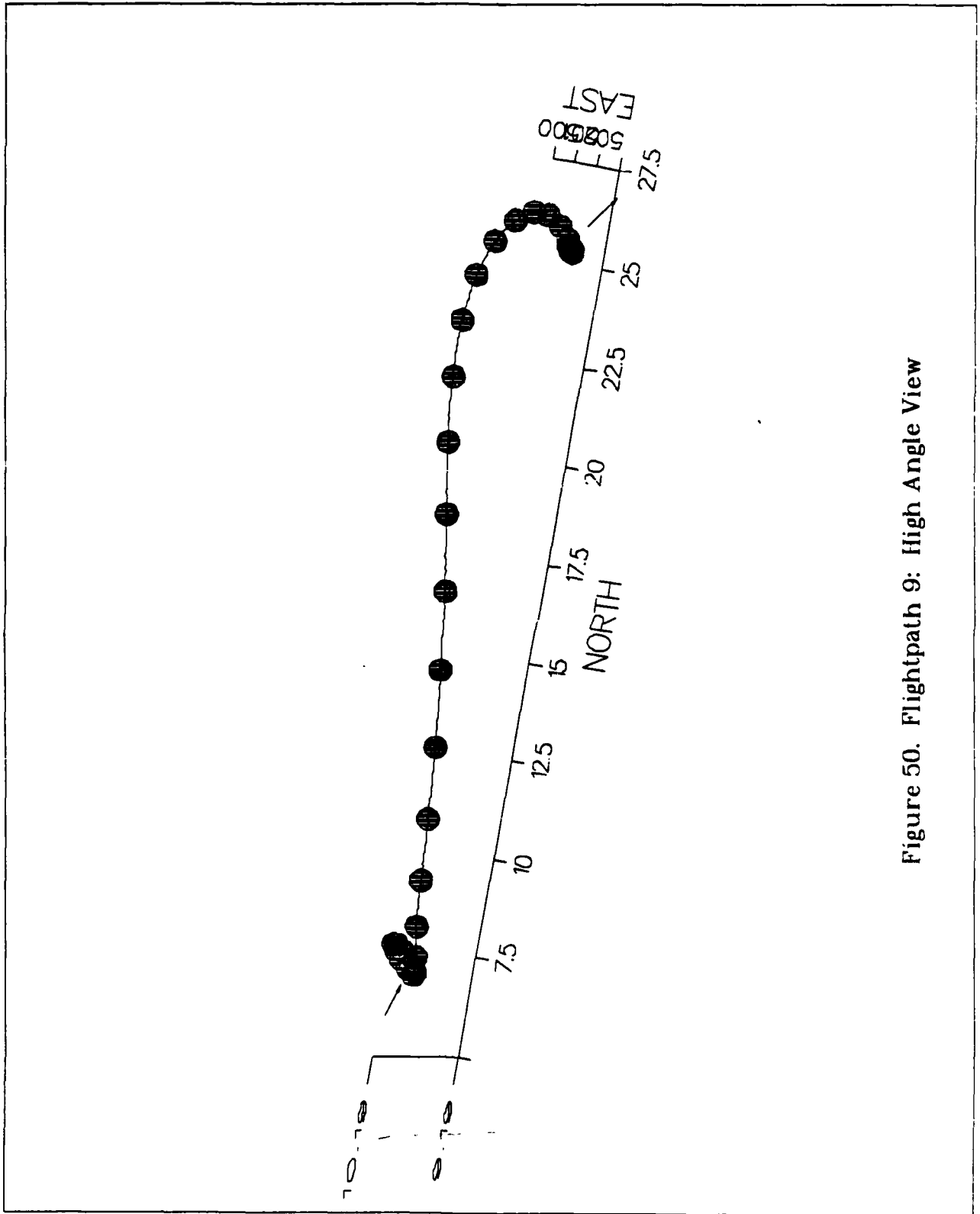

Figure 50. Flightpath 9: High Angle View

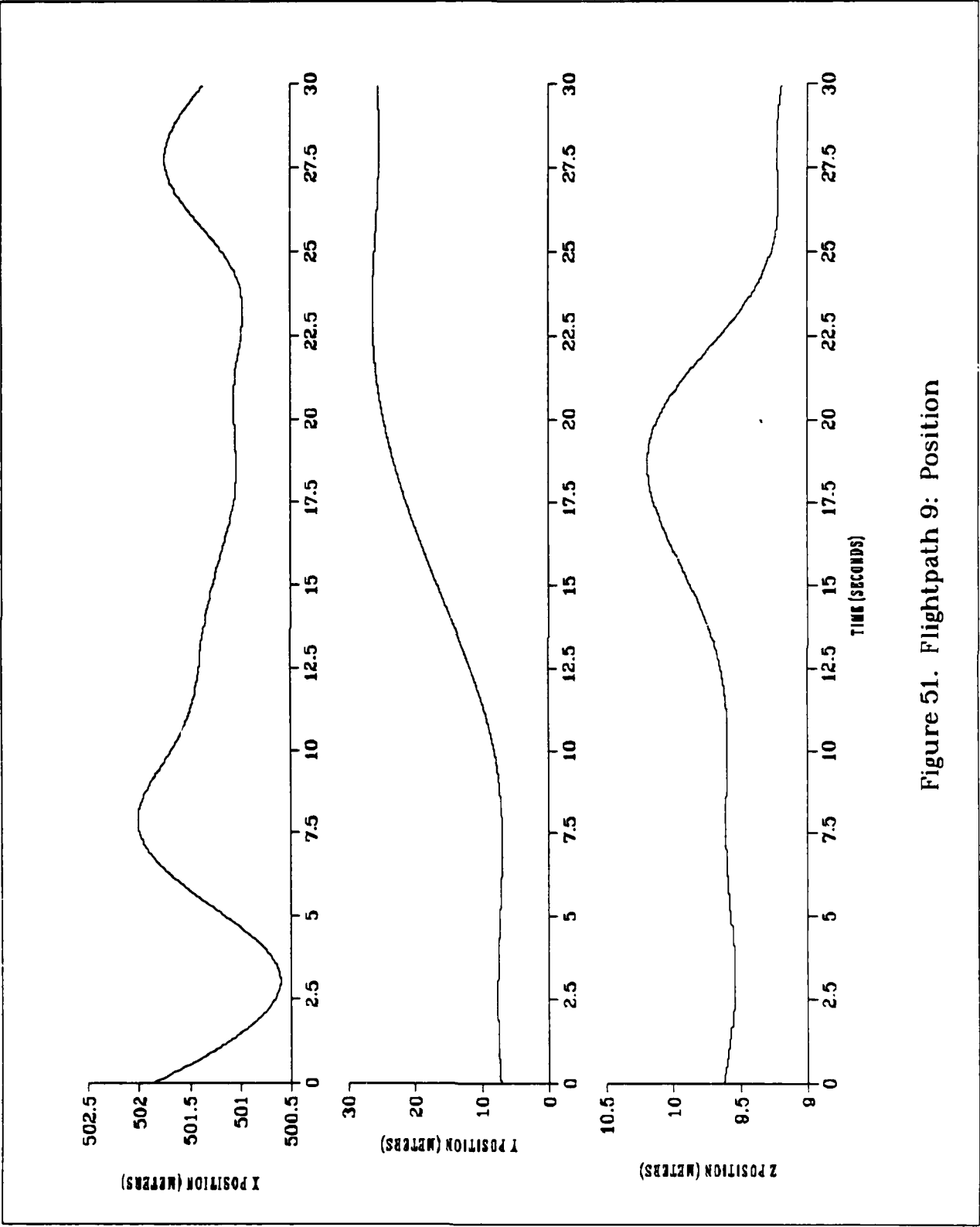

Figure 51. Flightpath 9: Position

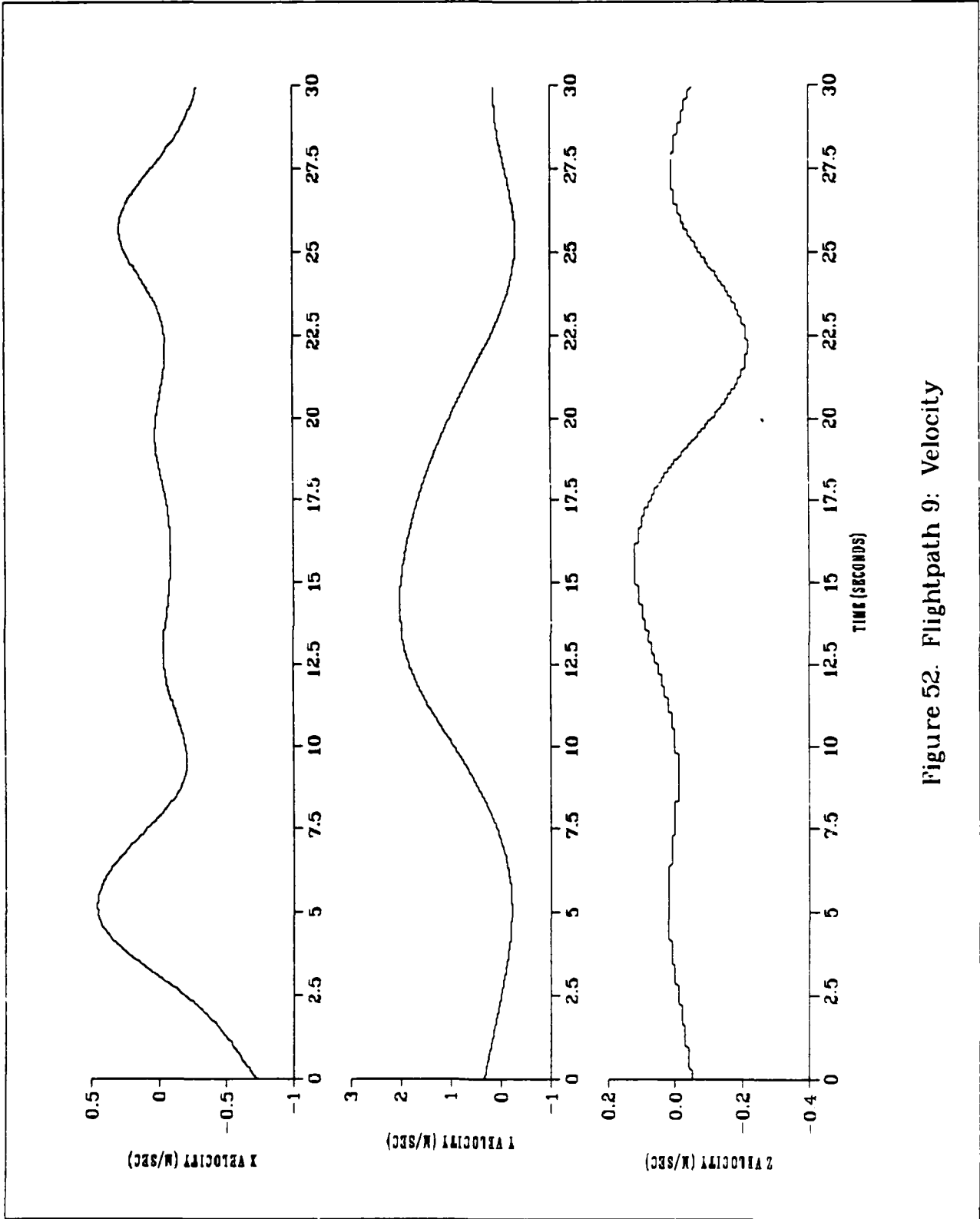

Figure 52. Flightpath 9: Velocity

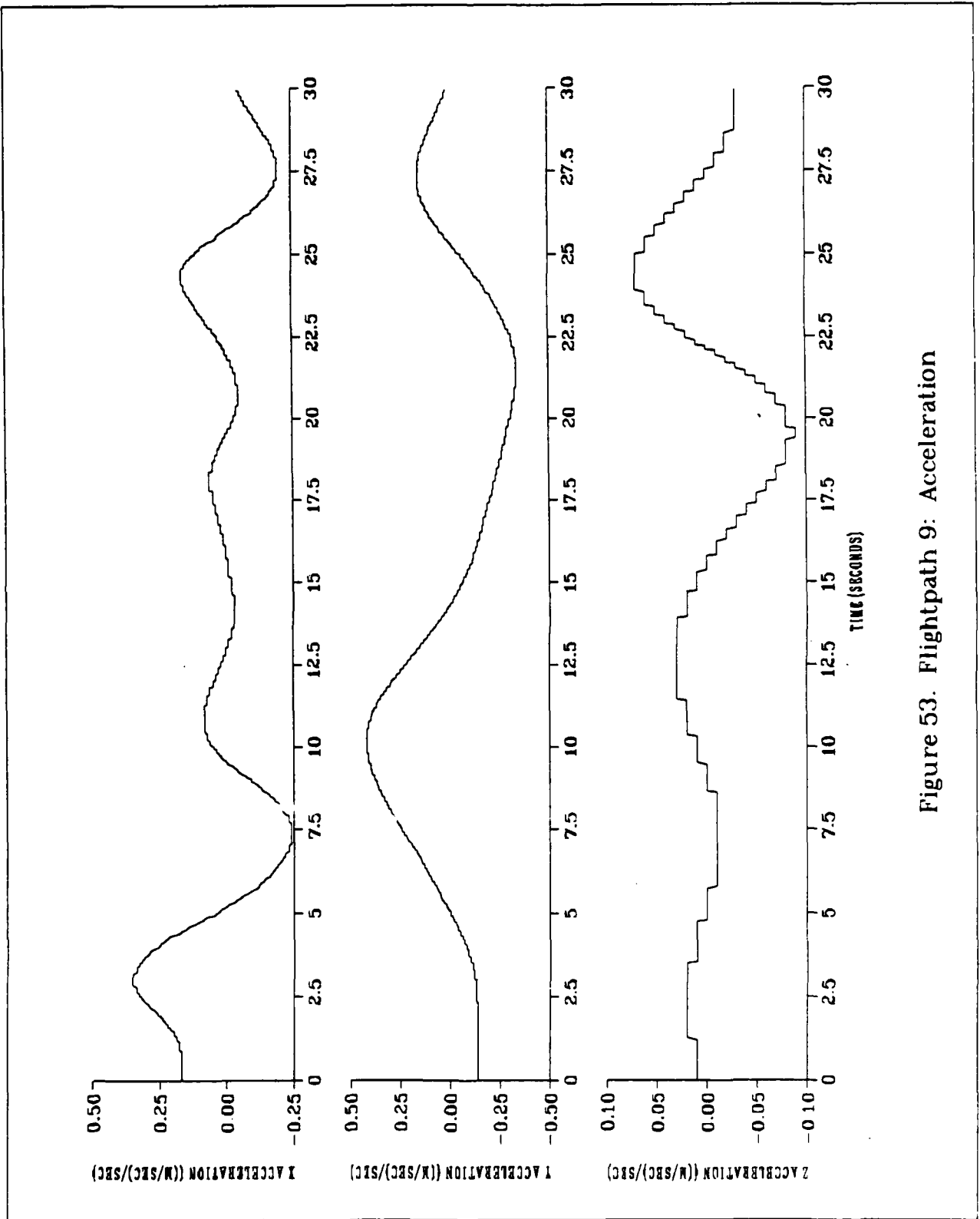

Figure 53. Flightpath 9: Acceleration

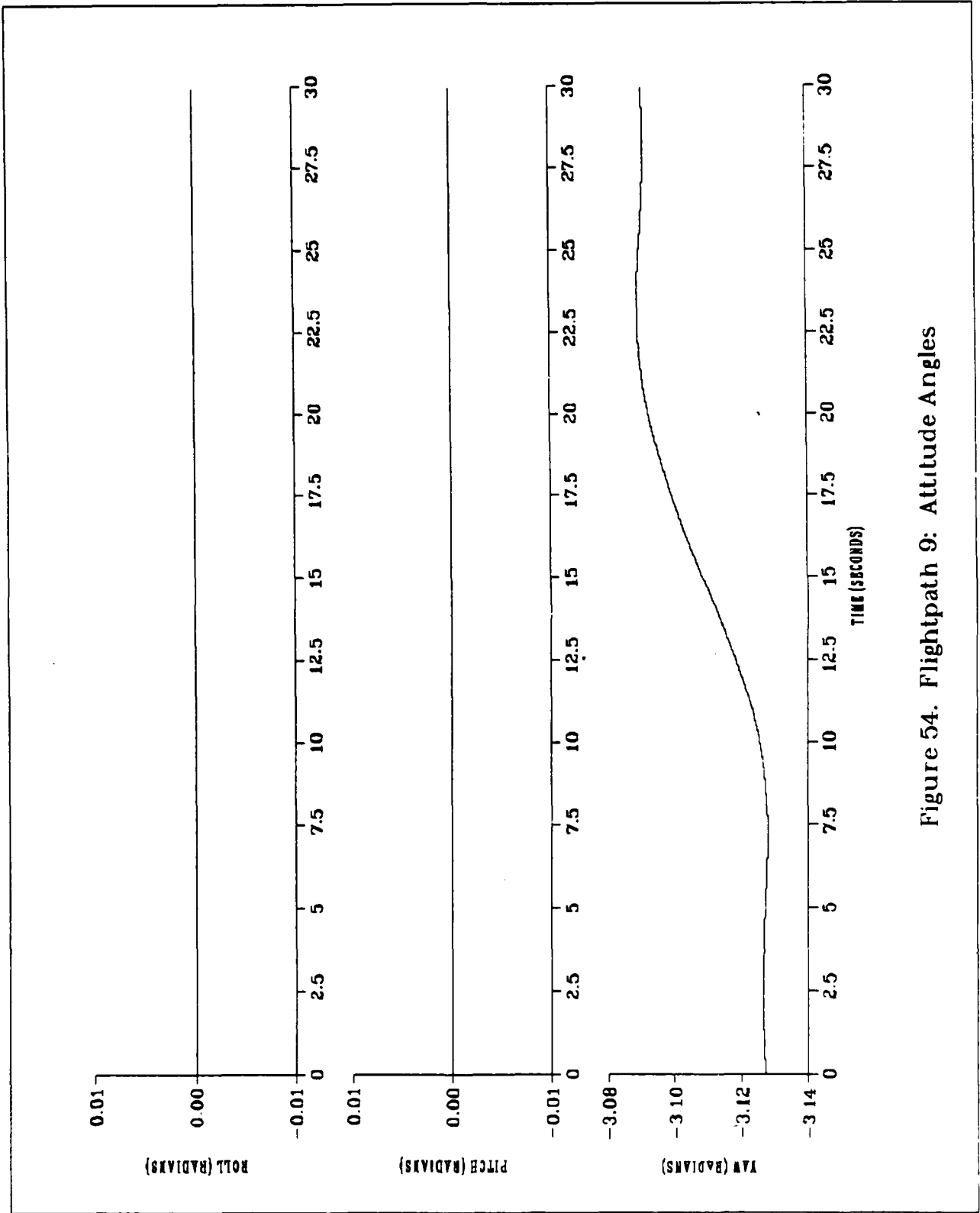

Figure 54. Flightpath 9: Attitude Angles

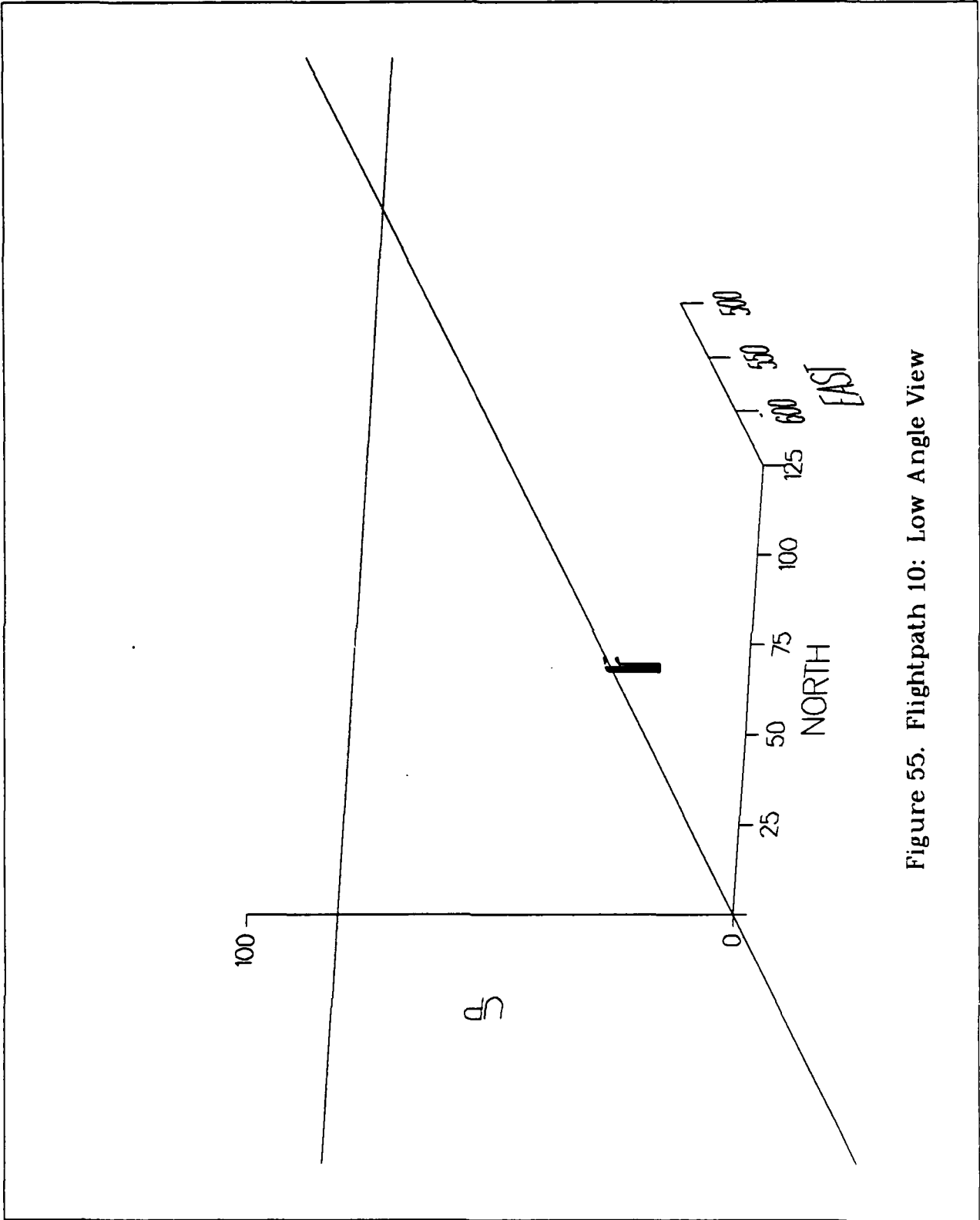

Figure 55. Flightpath 10: Low Angle View



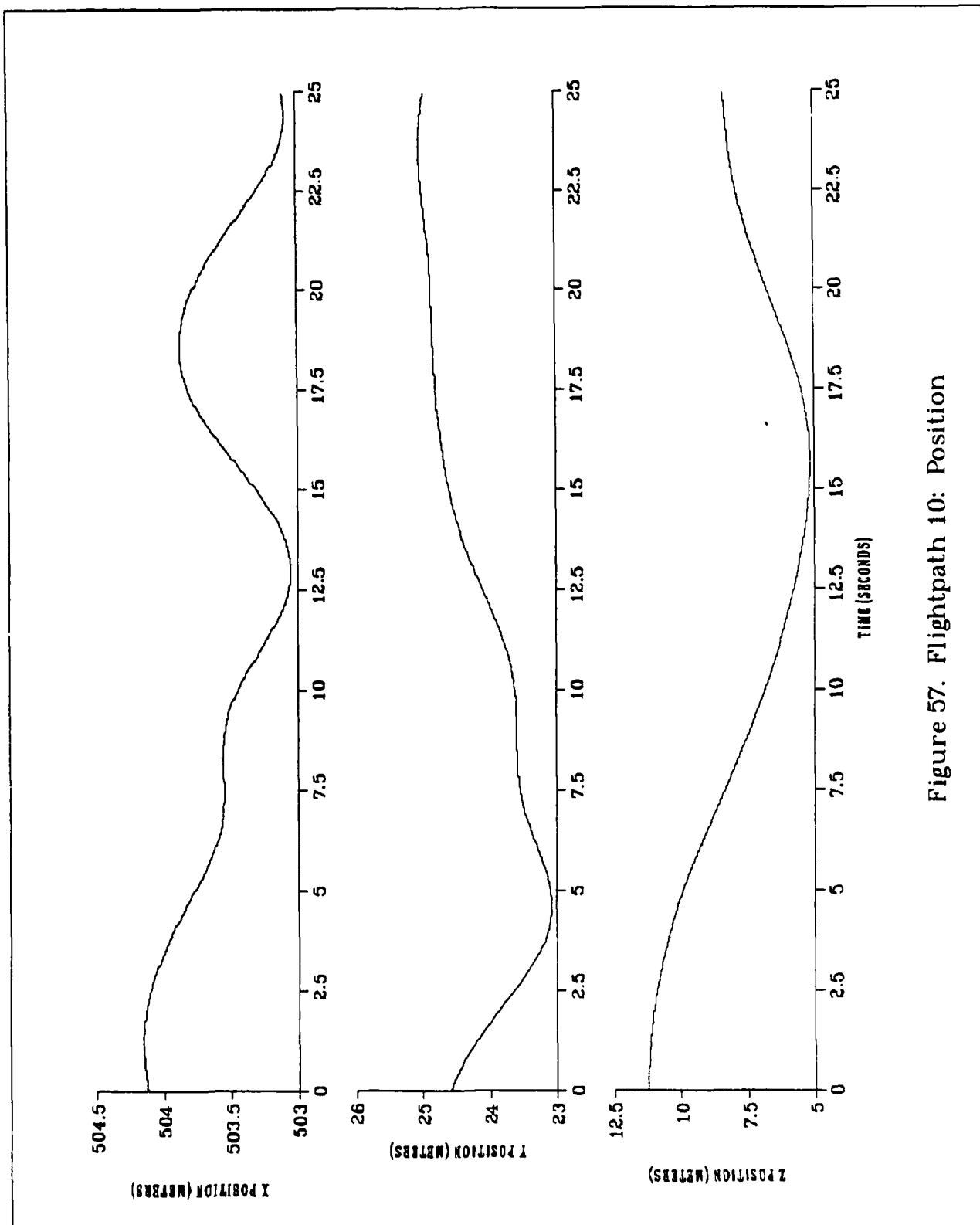

Figure 57. Flightpath 10: Position

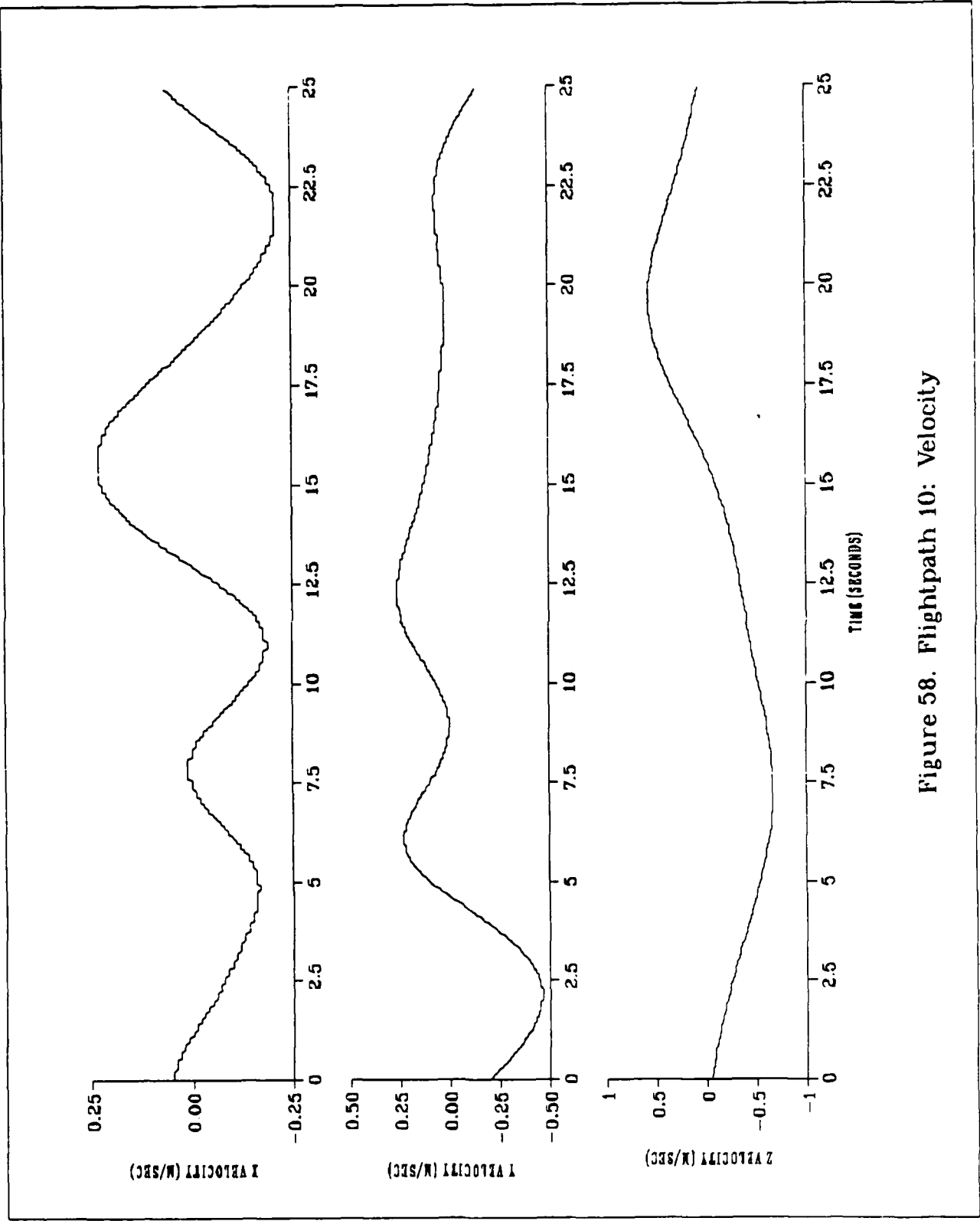

Figure 58. Flightpath 10: Velocity

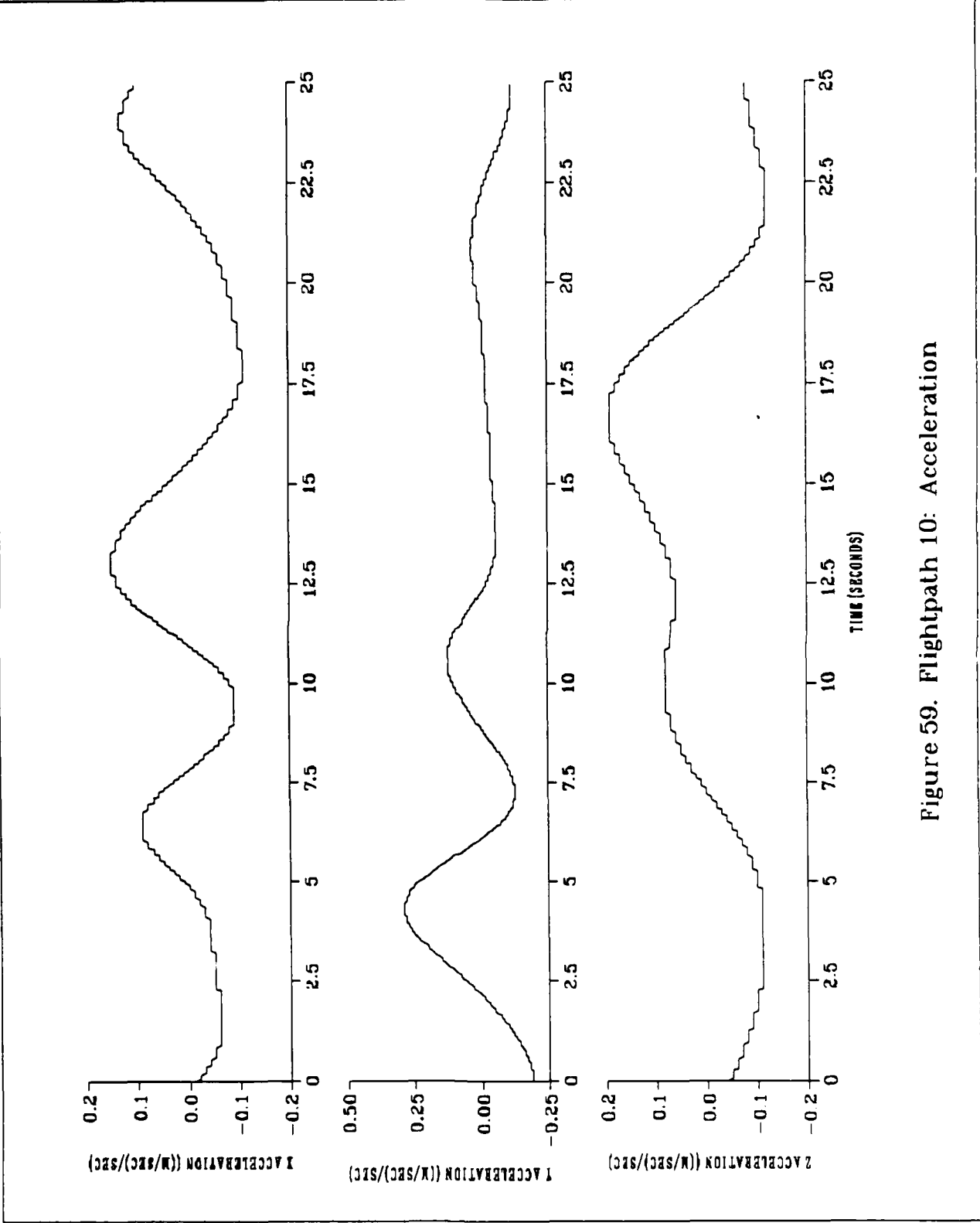

Figure 59. Flightpath 10: Acceleration

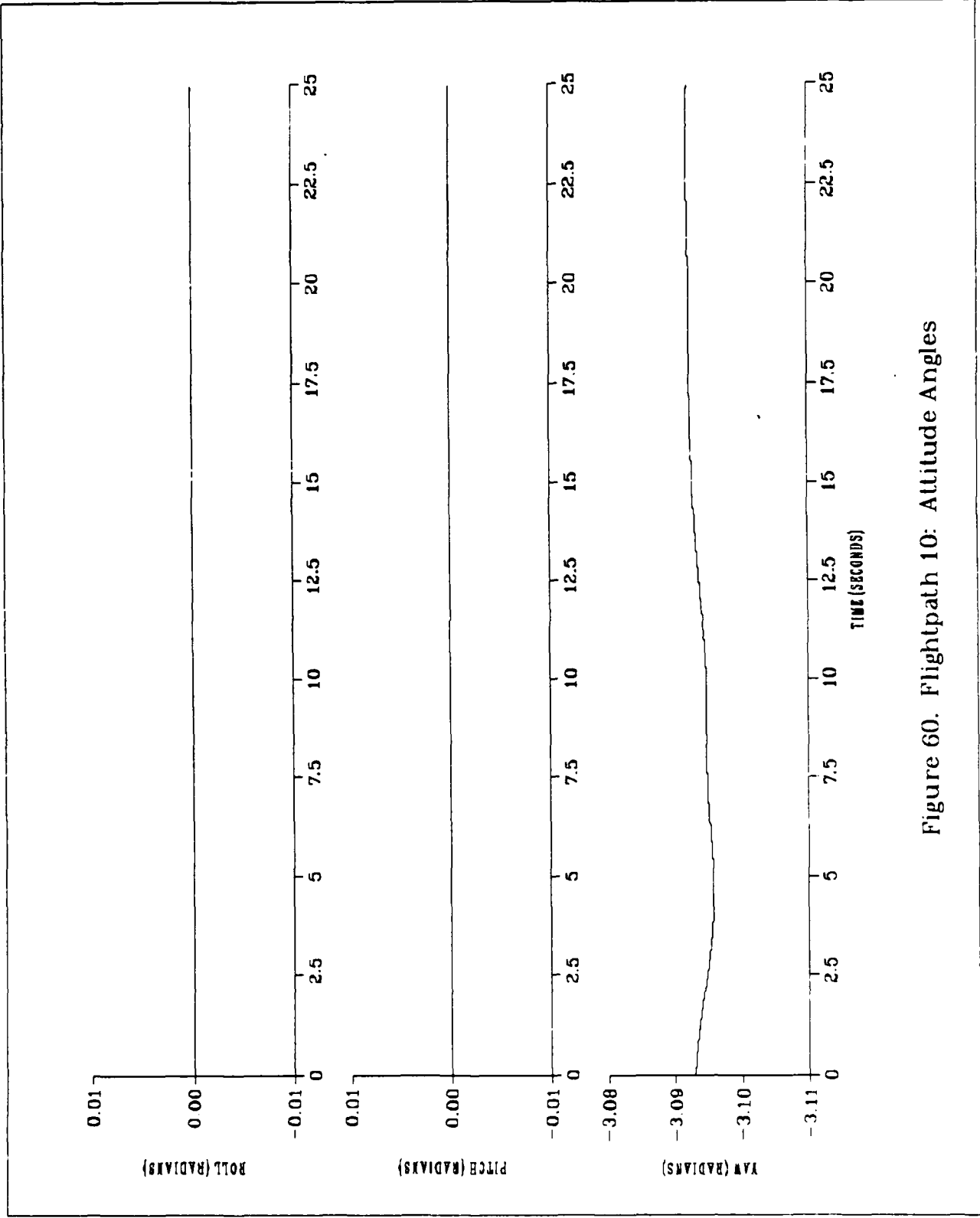

Figure 60. Flightpath 10: Attitude Angles

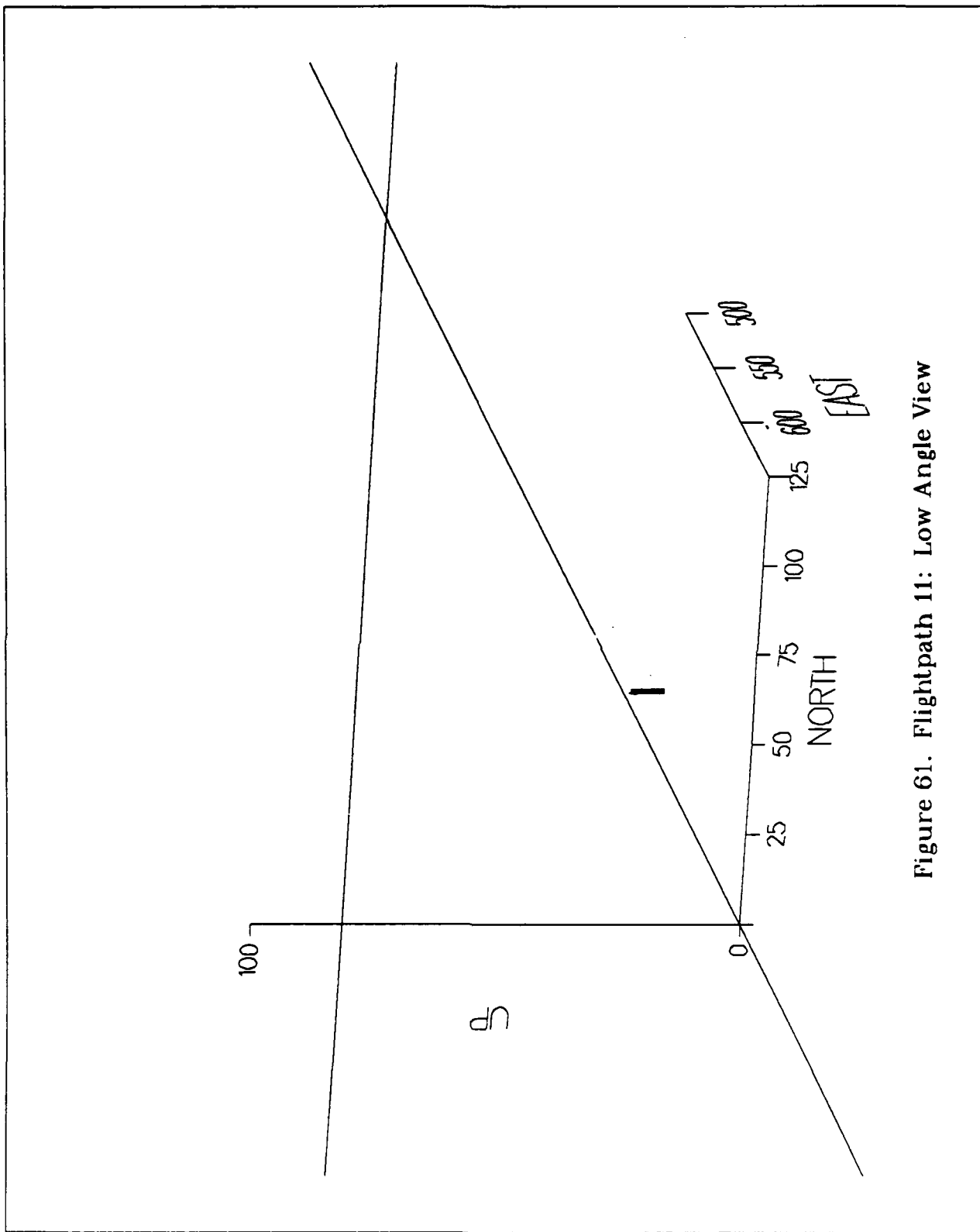

Figure 61. Flightpath 11: Low Angle View

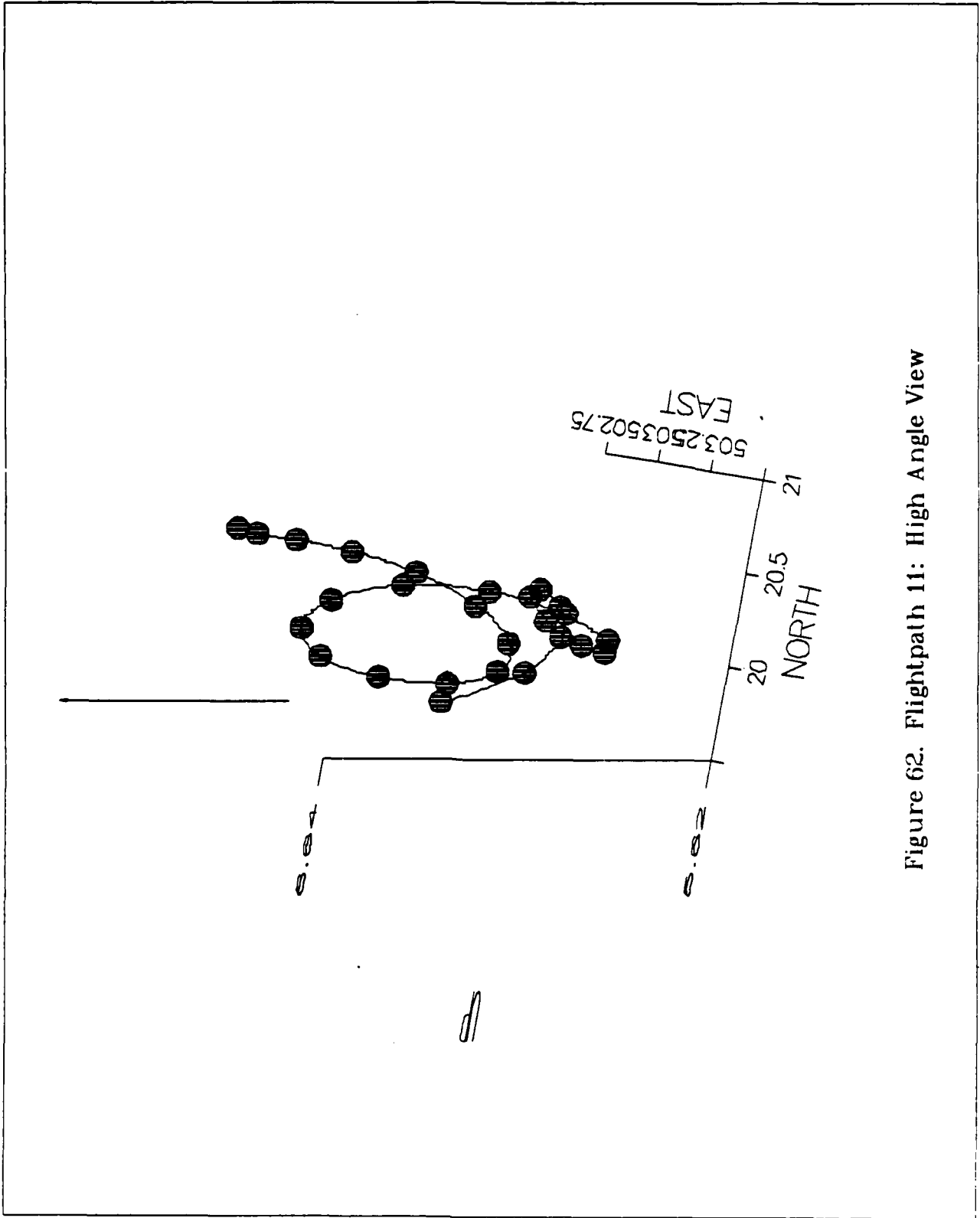

Figure 62. Flightpath 11: High Angle View

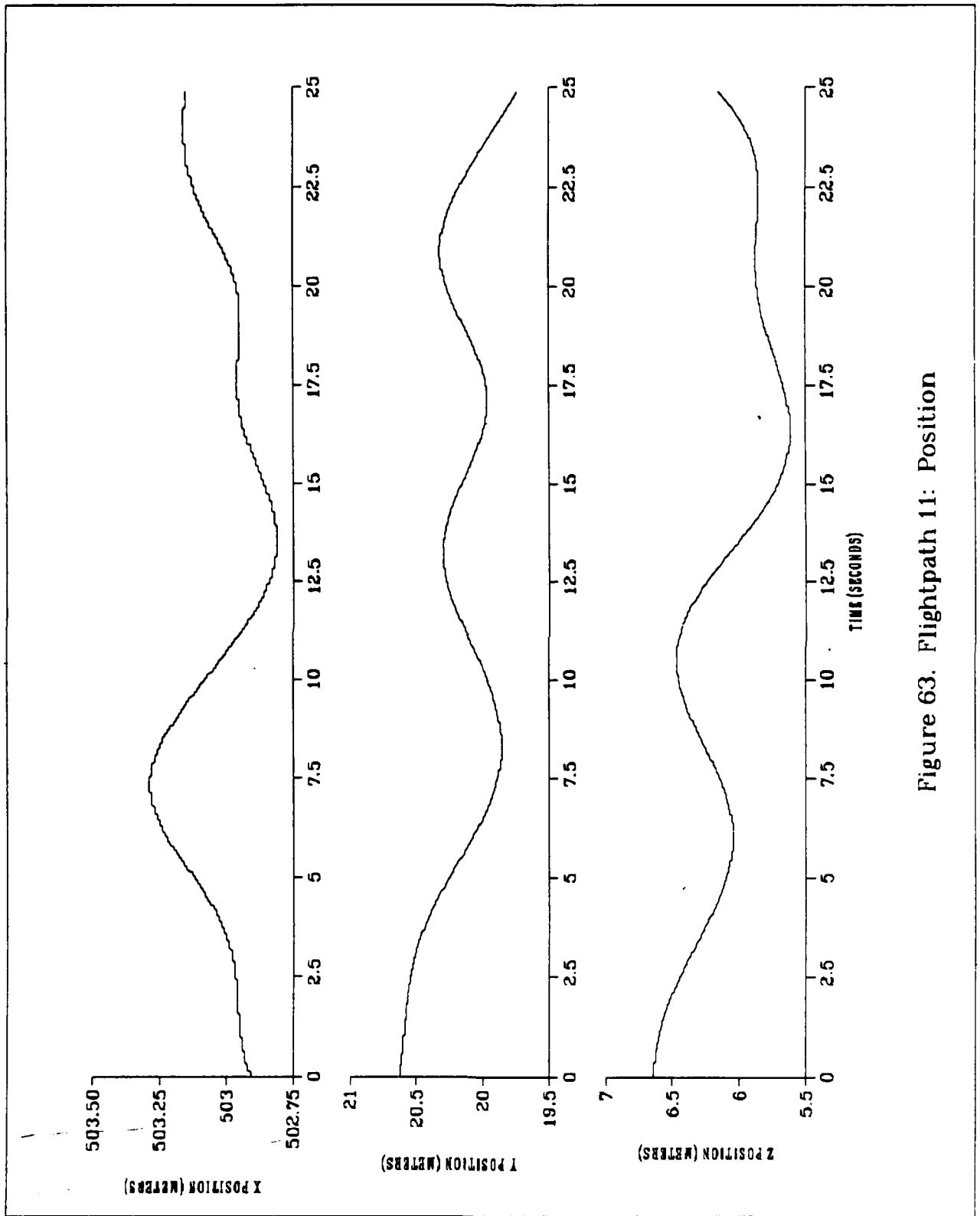

Figure 63. Flightpath 11: Position

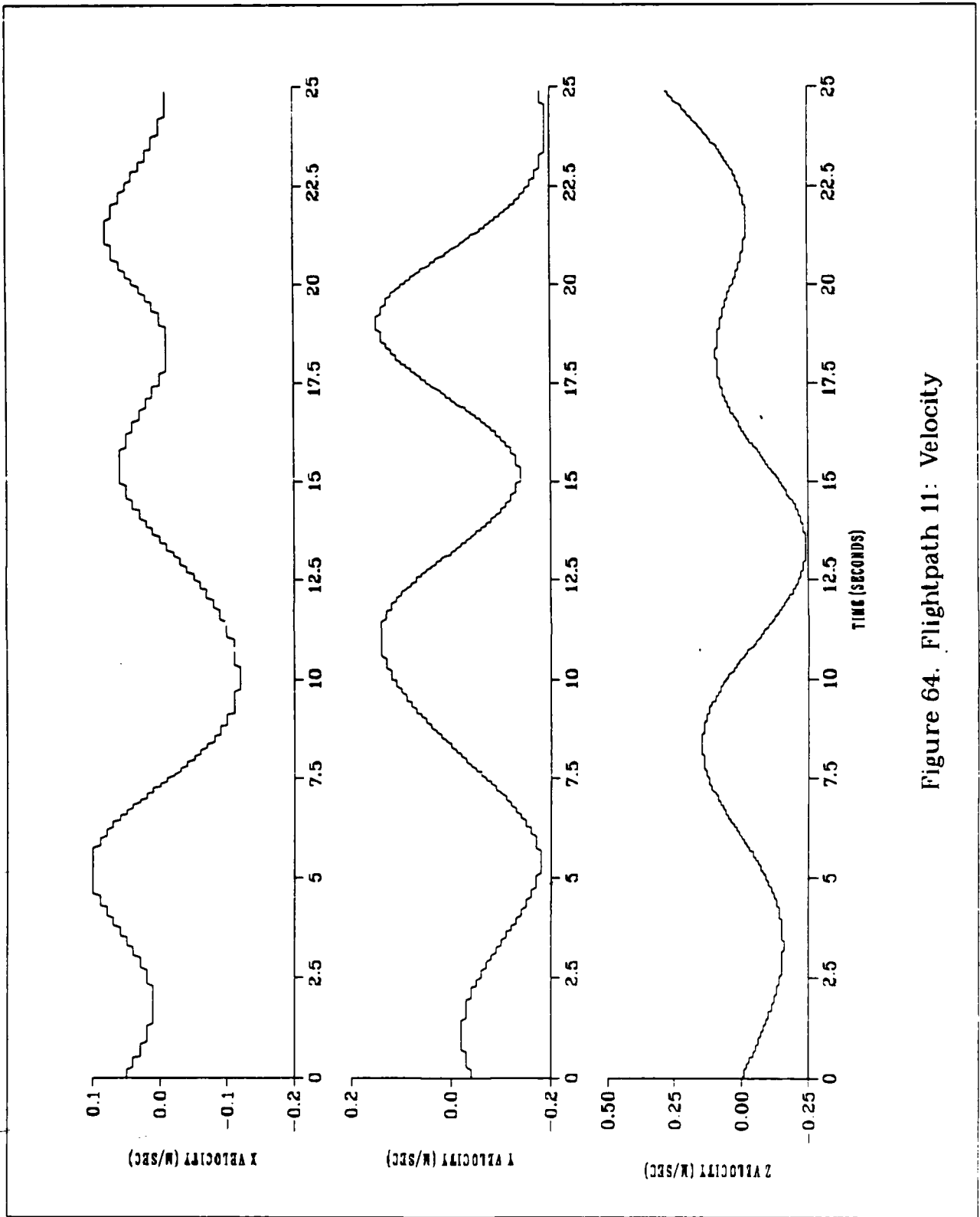

Figure 64. Flightpath 11: Velocity

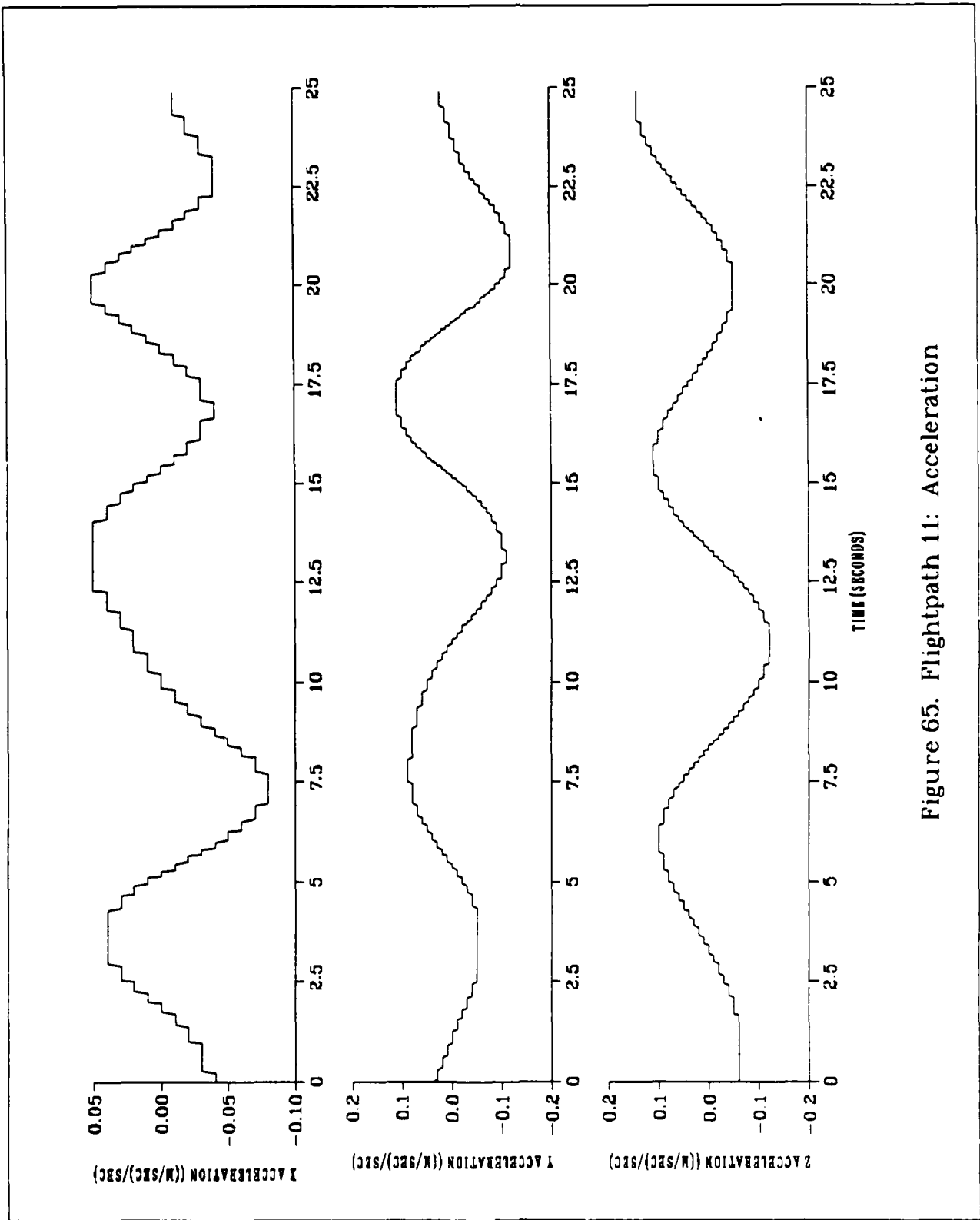

Figure 65. Flightpath 11: Acceleration

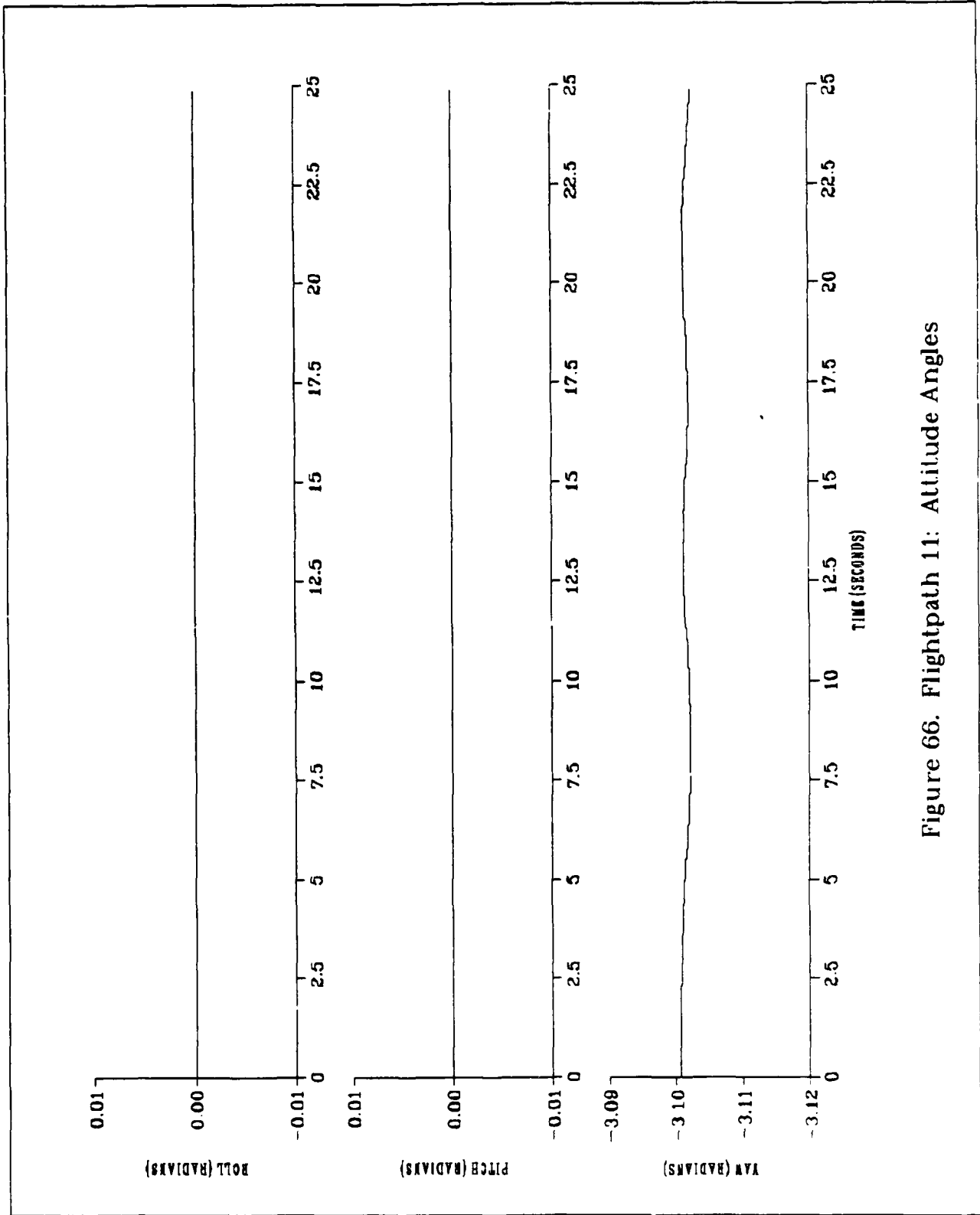

Figure 66. Flightpath 11: Attitude Angles

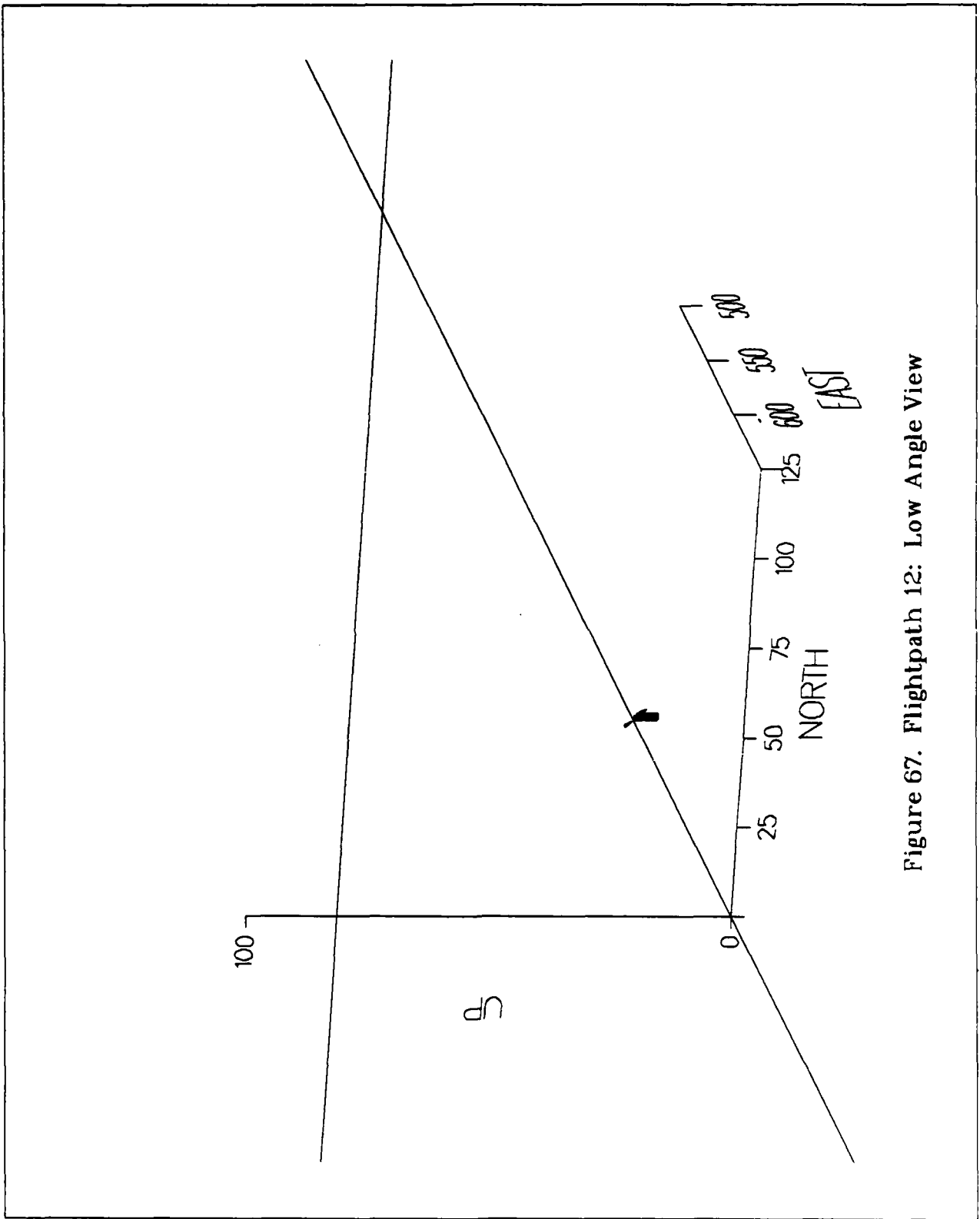

Figure 67. Flightpath 12: Low Angle View

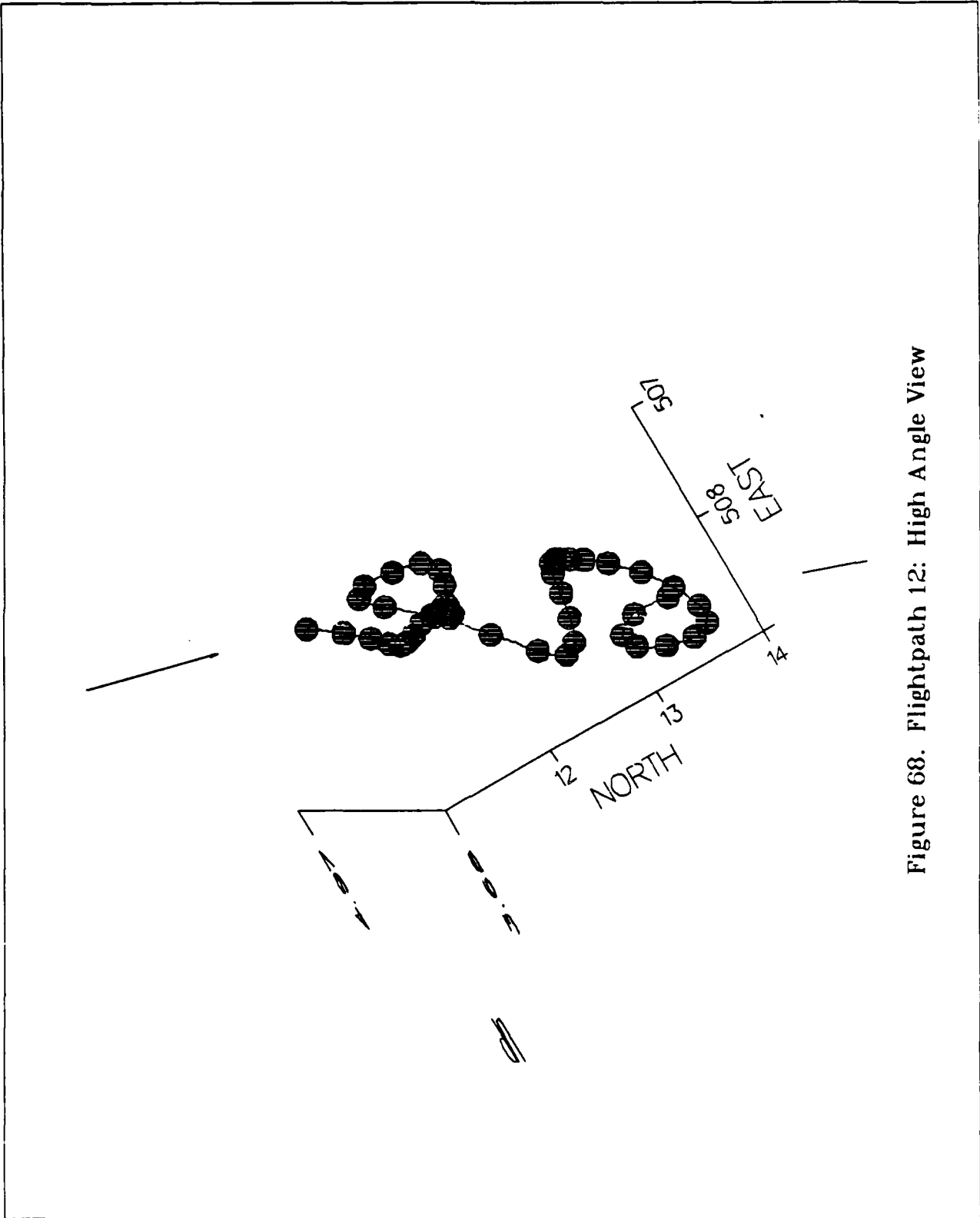

Figure 68. Flightpath 12: High Angle View

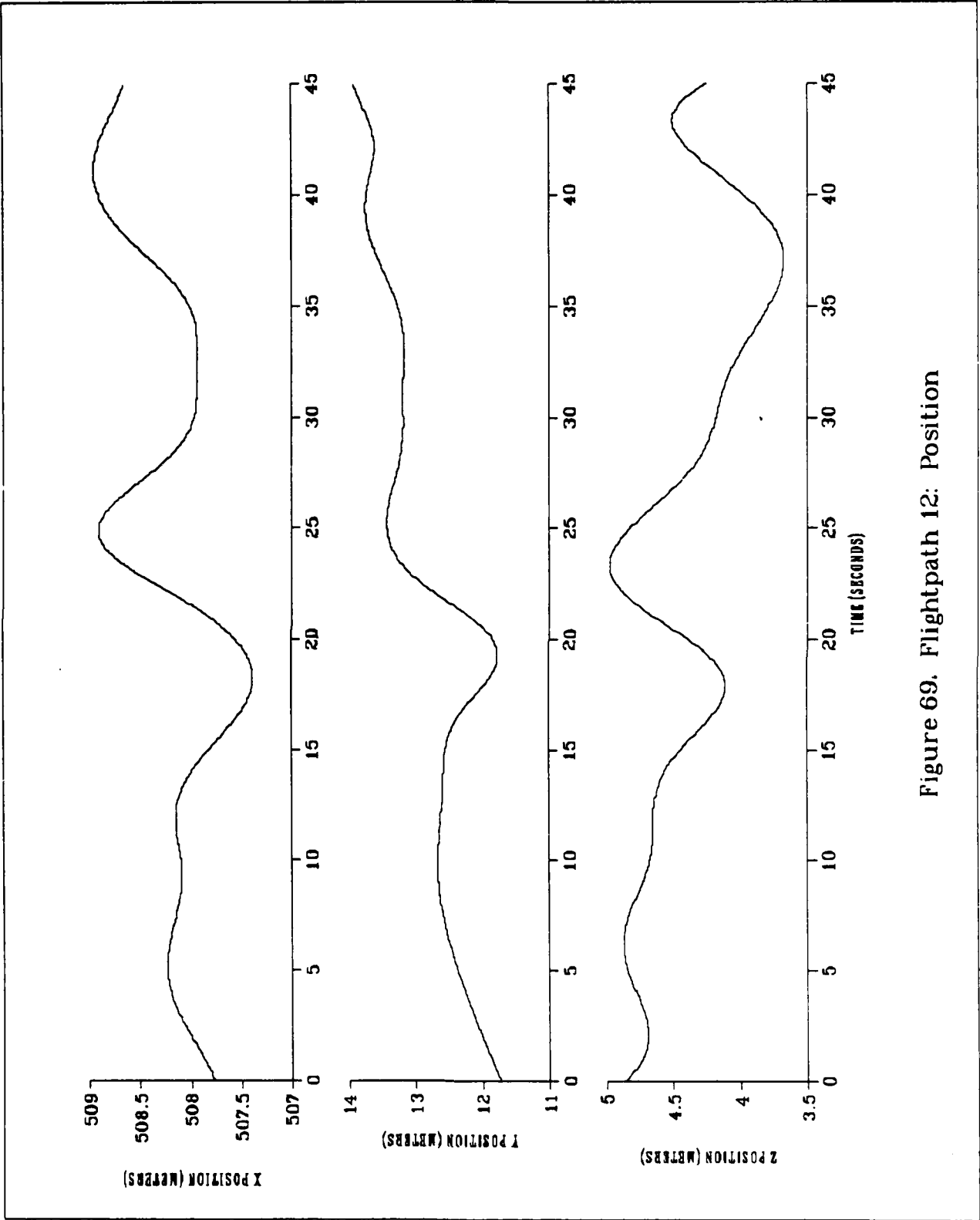

Figure 69. Flightpath 12: Position

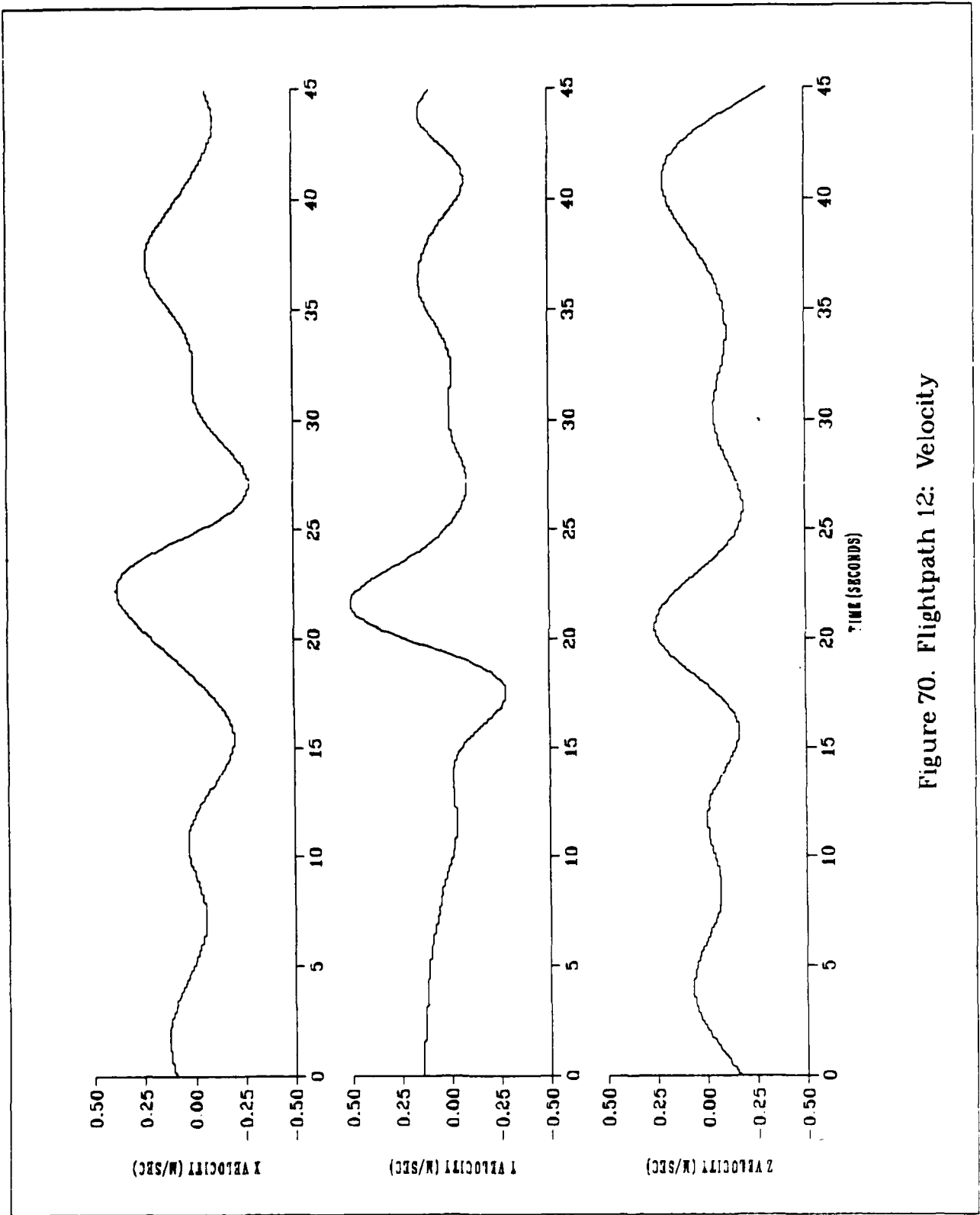

Figure 70. Flightpath 12: Velocity

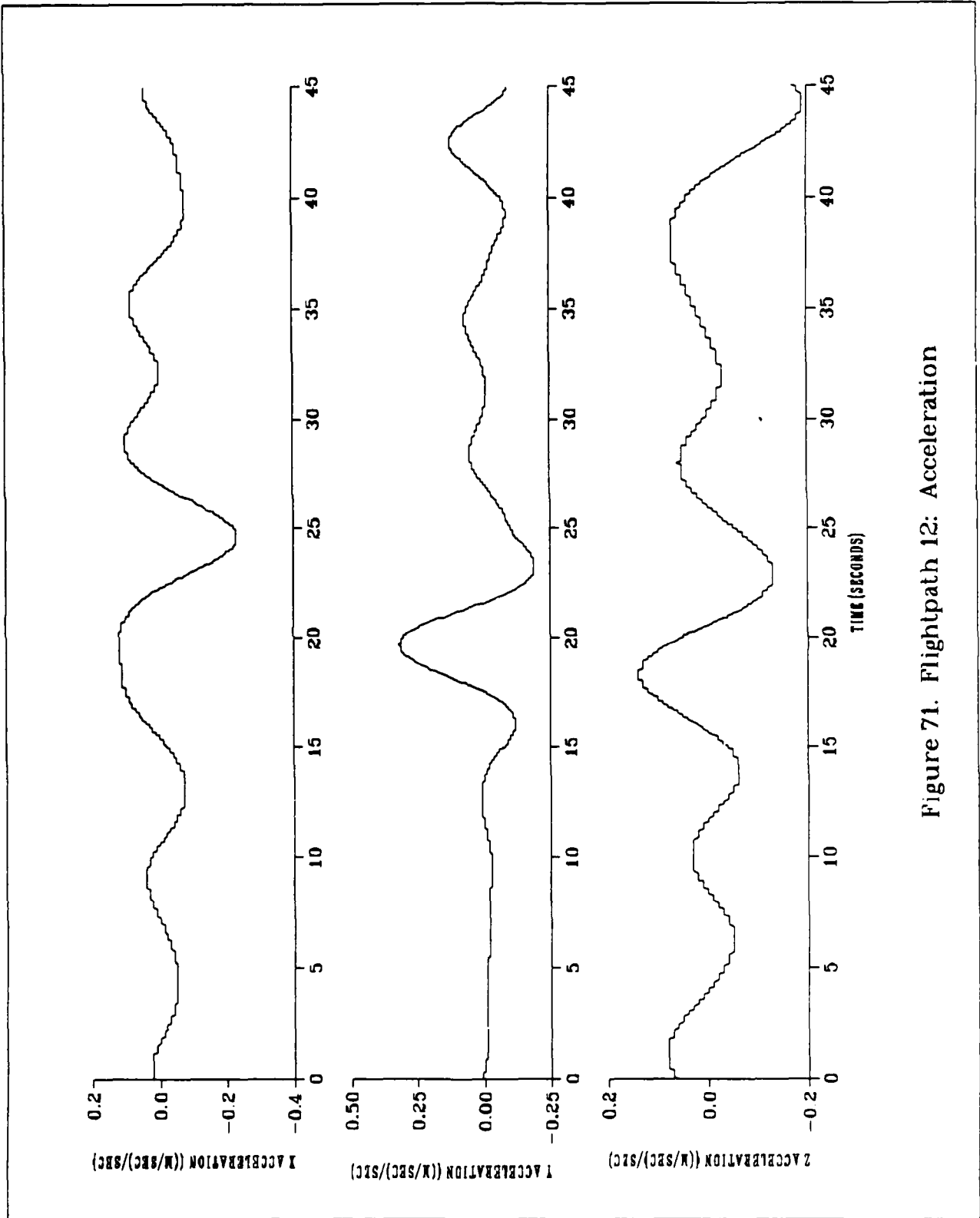

Figure 71. Flightpath 12: Acceleration

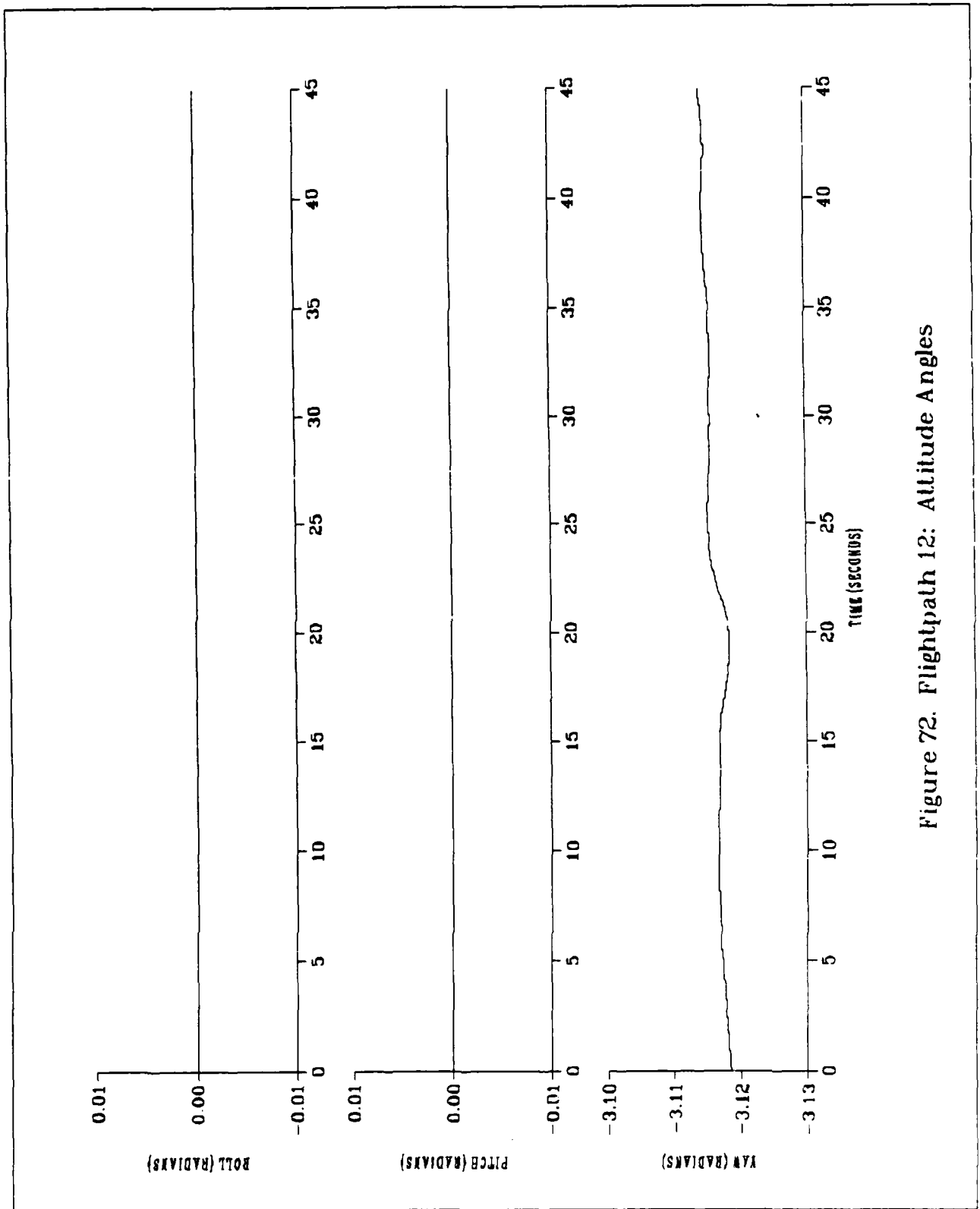

Figure 72. Flightpath 12: Attitude Angles

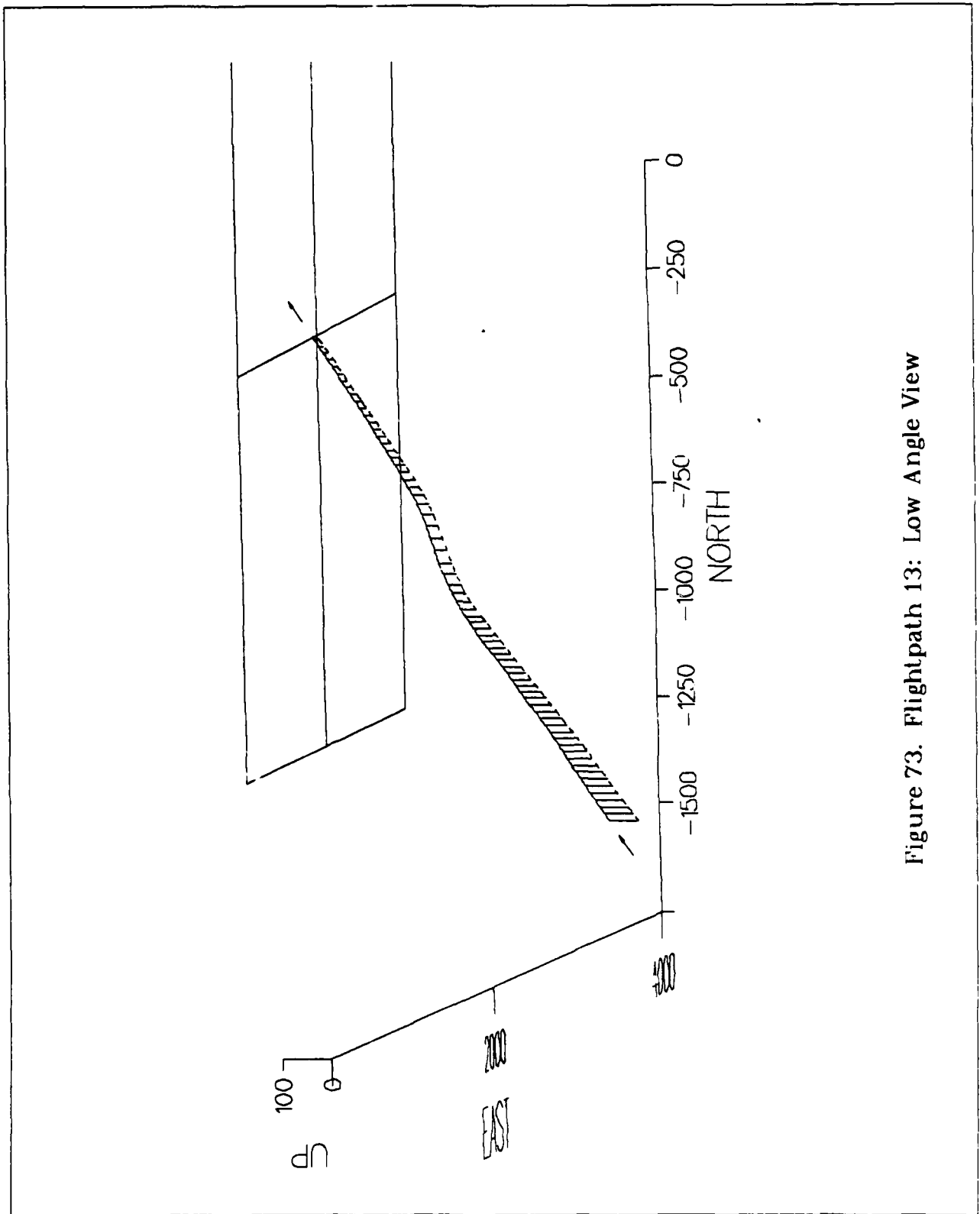

Figure 73. Flightpath 13: Low Angle View

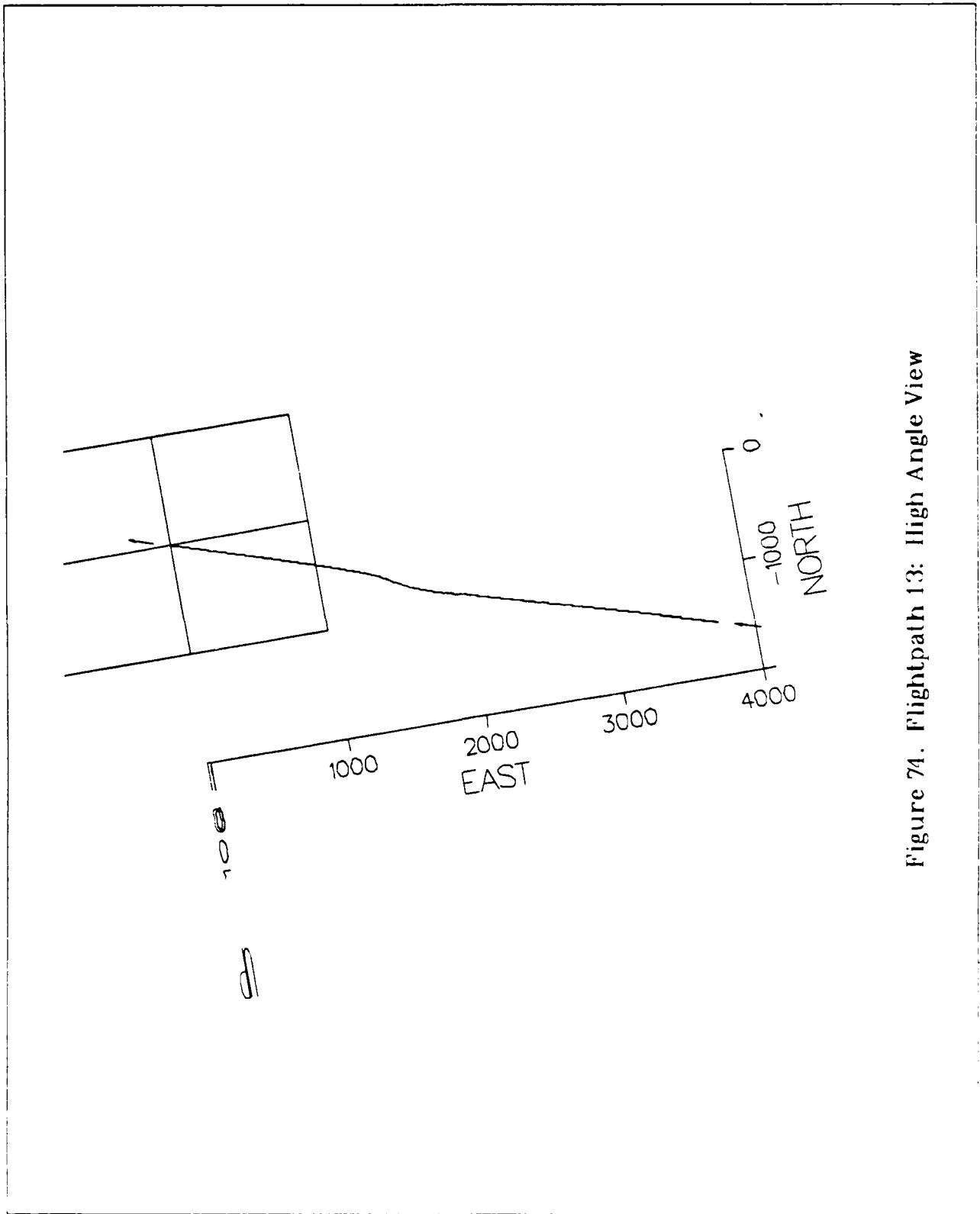

Figure 74. Flightpath 13: High Angle View

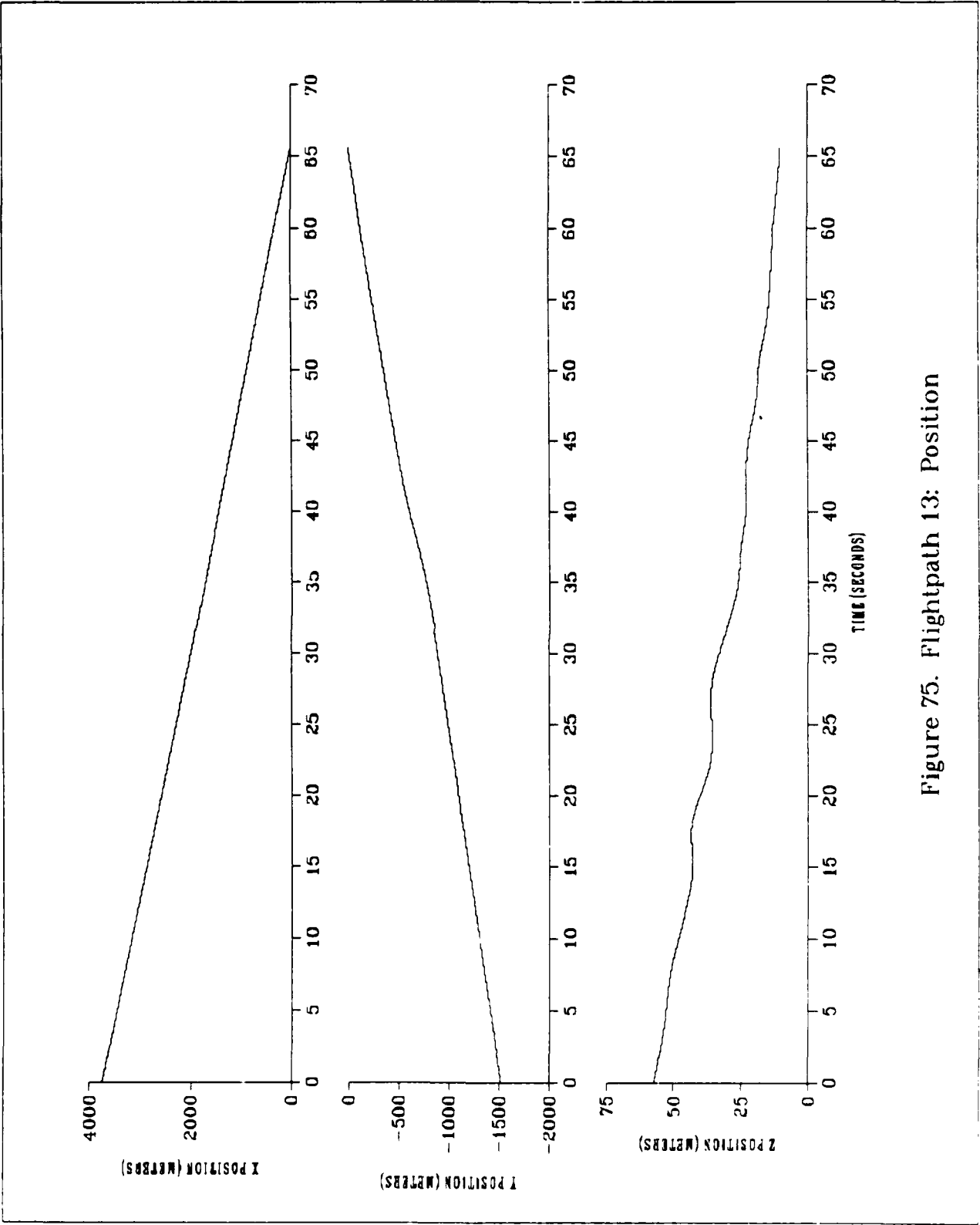

Figure 75. Flightpath 13: Position

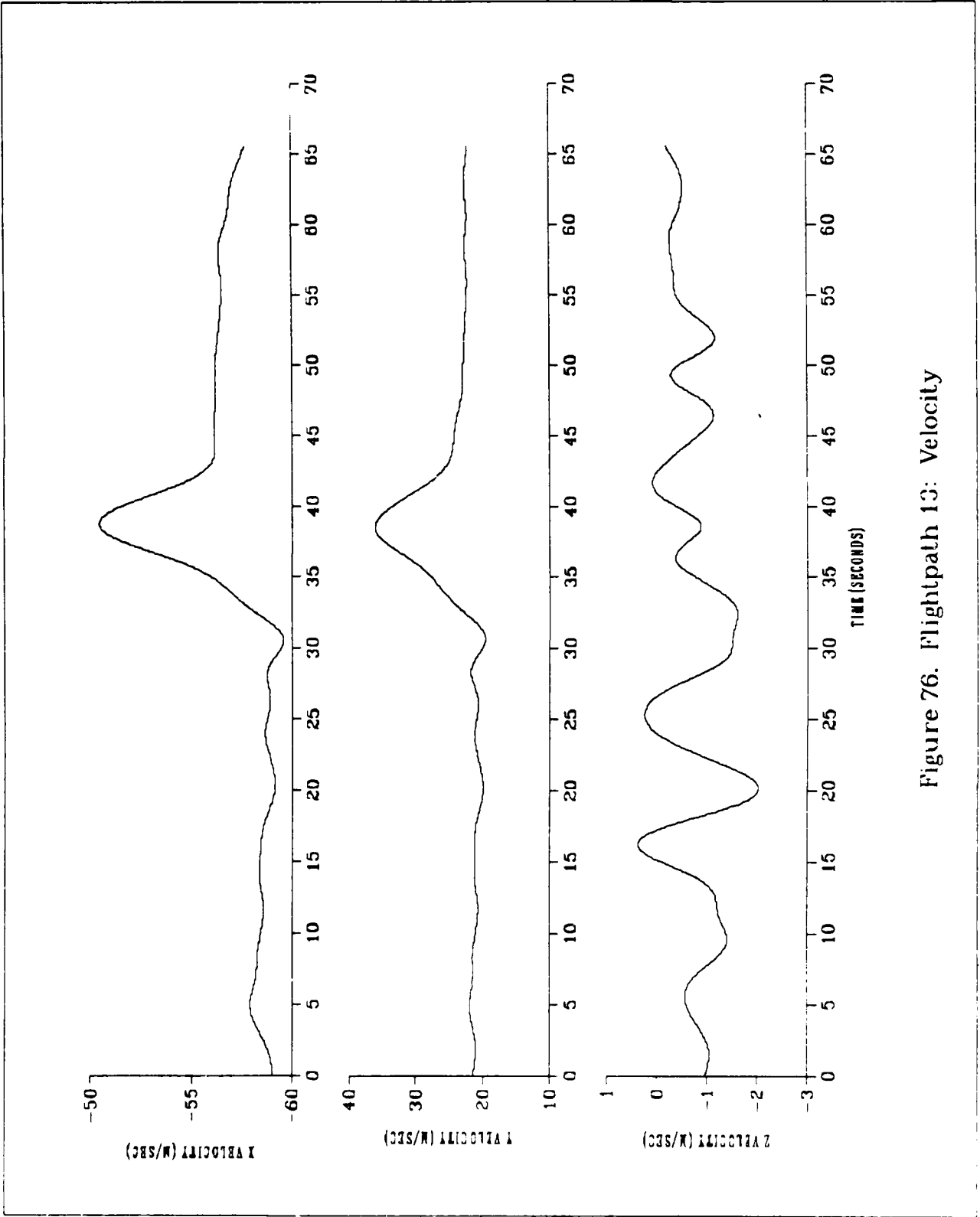

Figure 76. Flightpath 13: Velocity

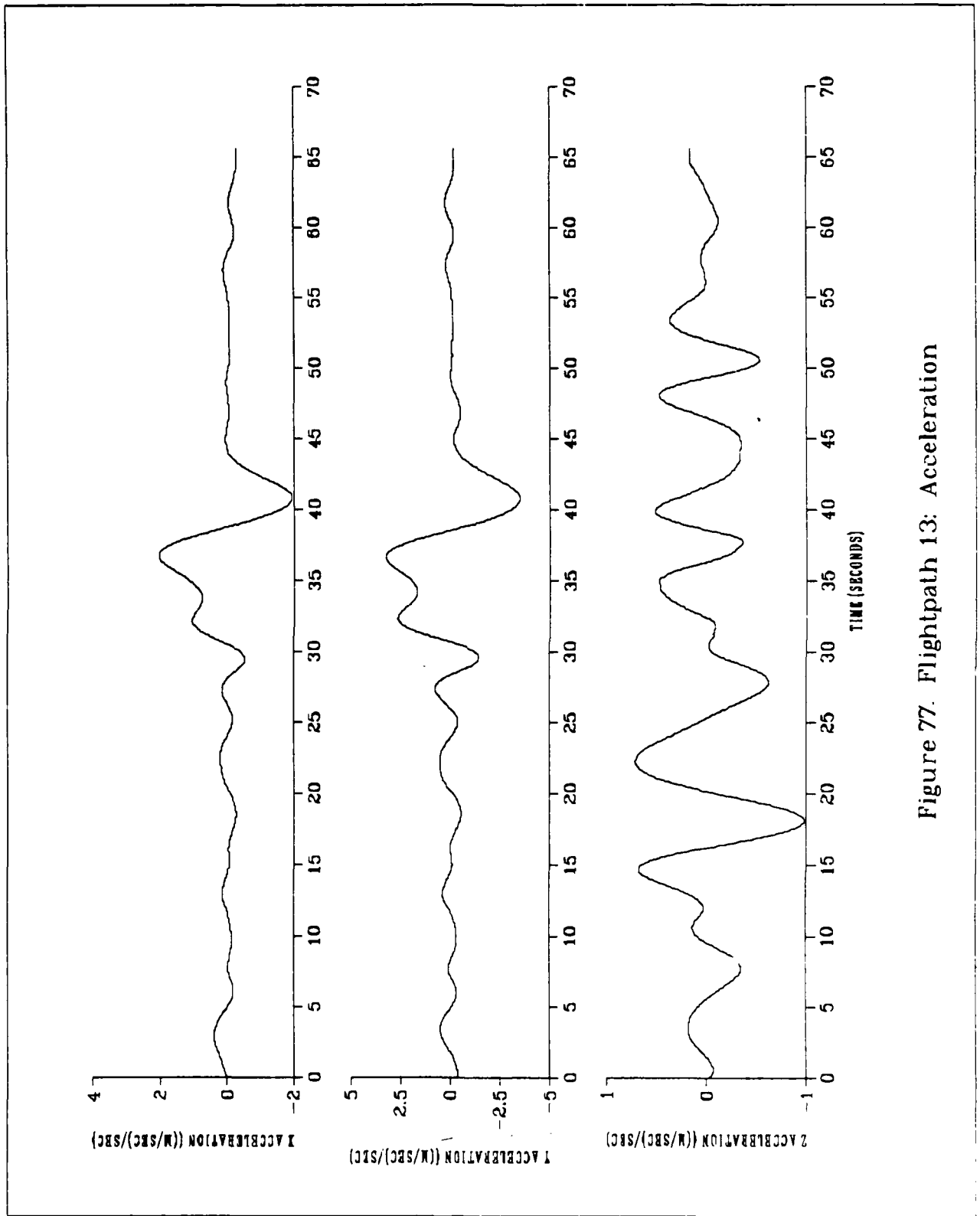

Figure 77. Flightpath 13: Acceleration

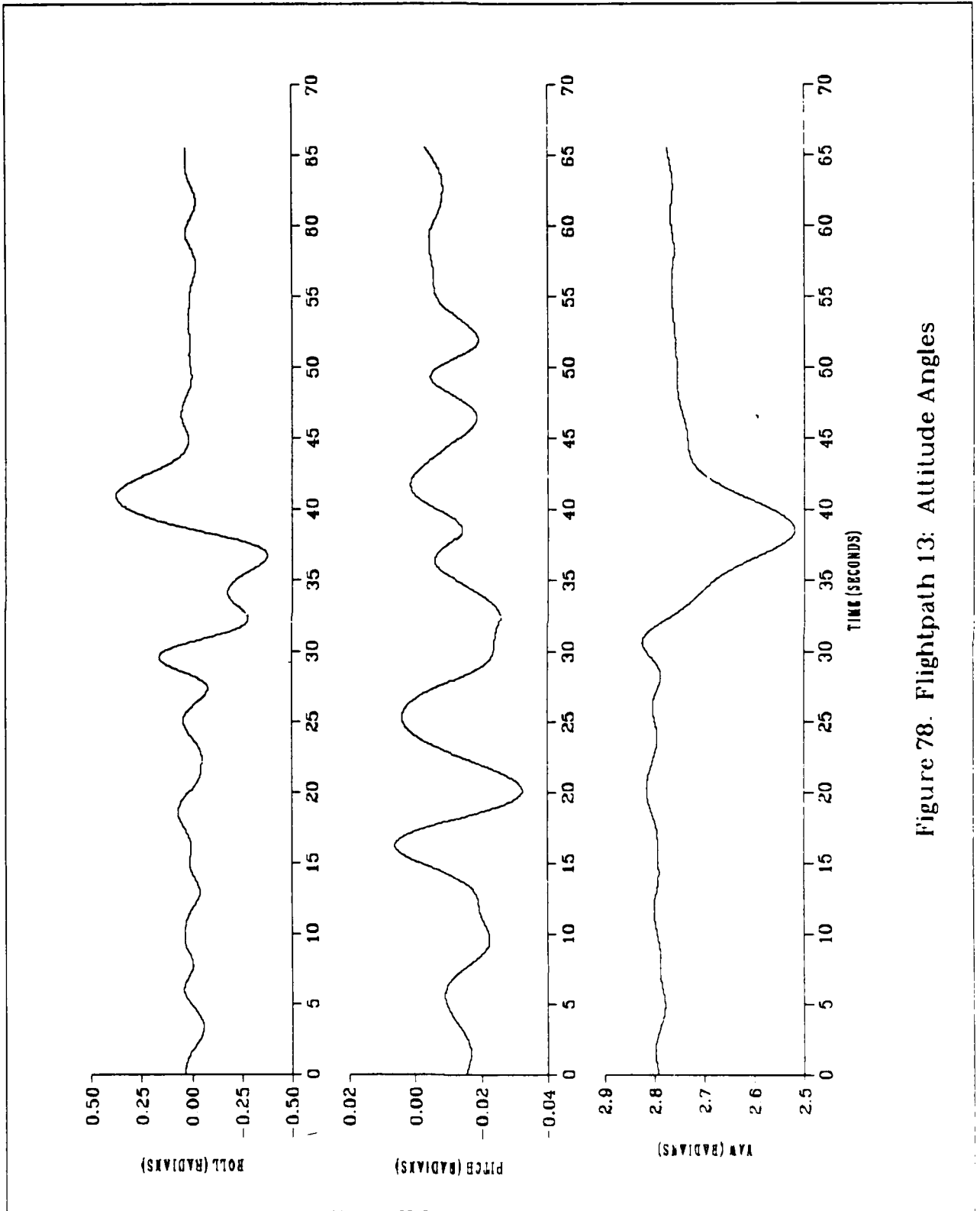

Figure 78. Flightpath 13: Attitude Angles

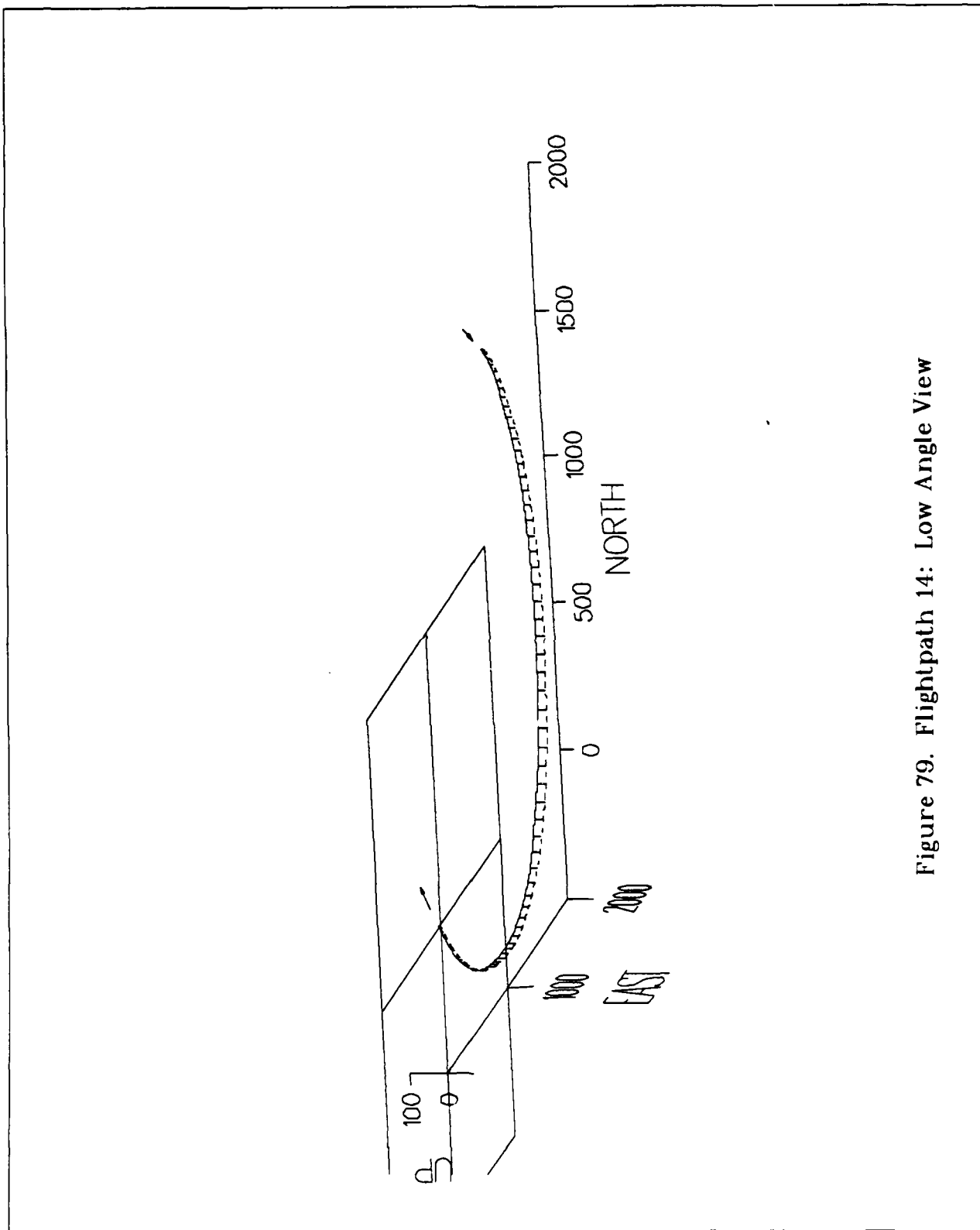

Figure 79. Flightpath 14: Low Angle View

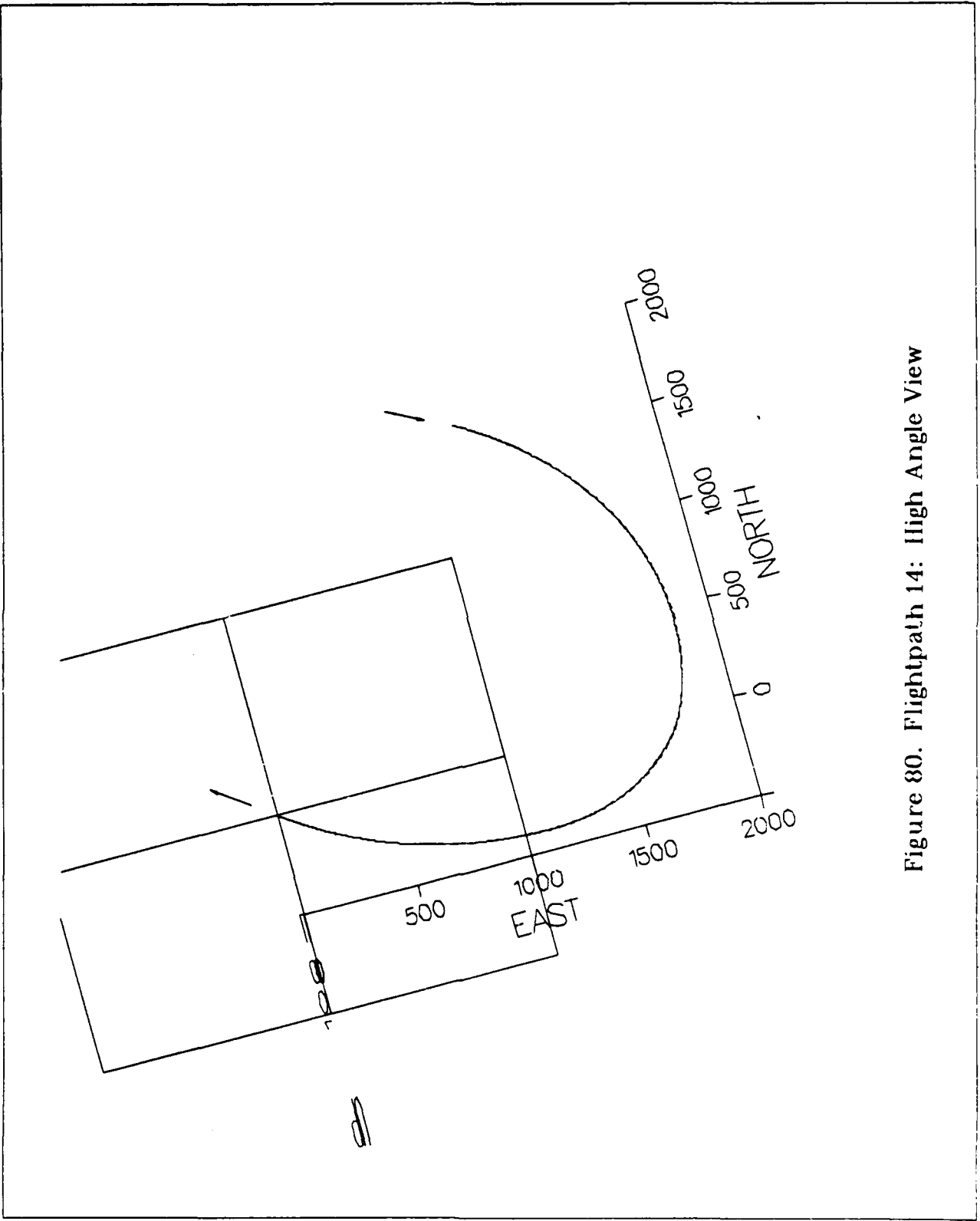

Figure 80. Flightpath 14: High Angle View

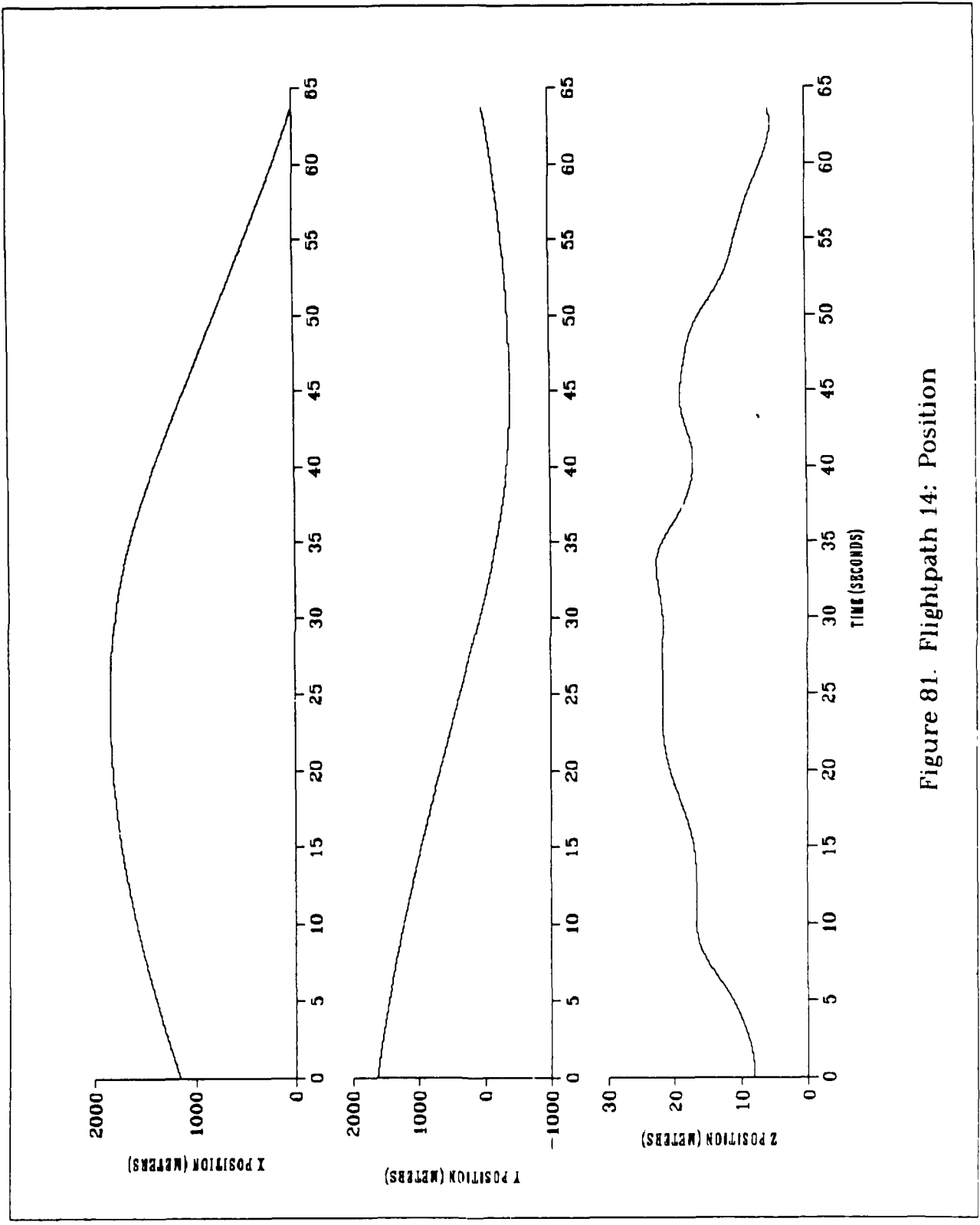

Figure 81. Flightpath 14: Position

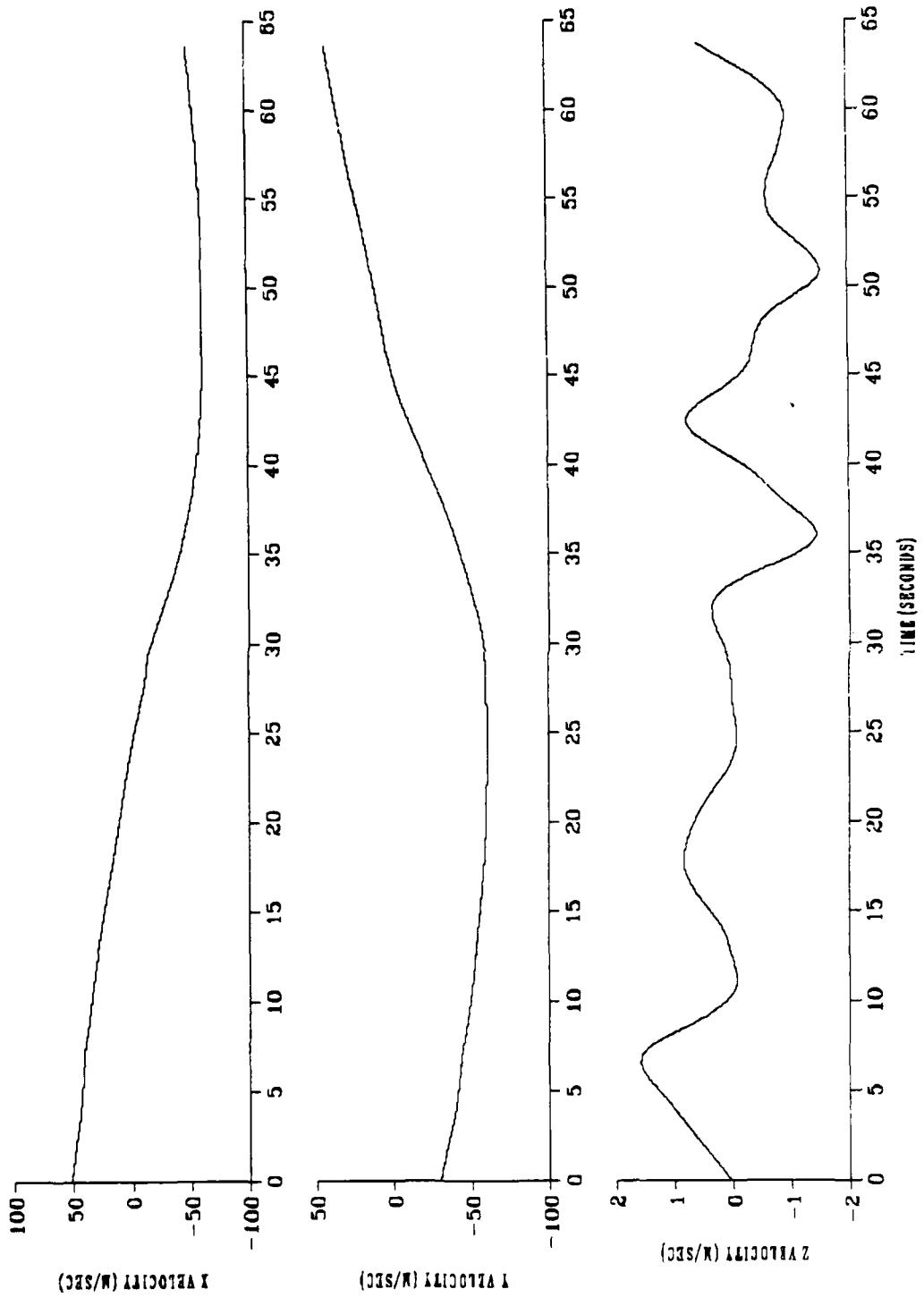

Figure 82. Flightpath 14: Velocity

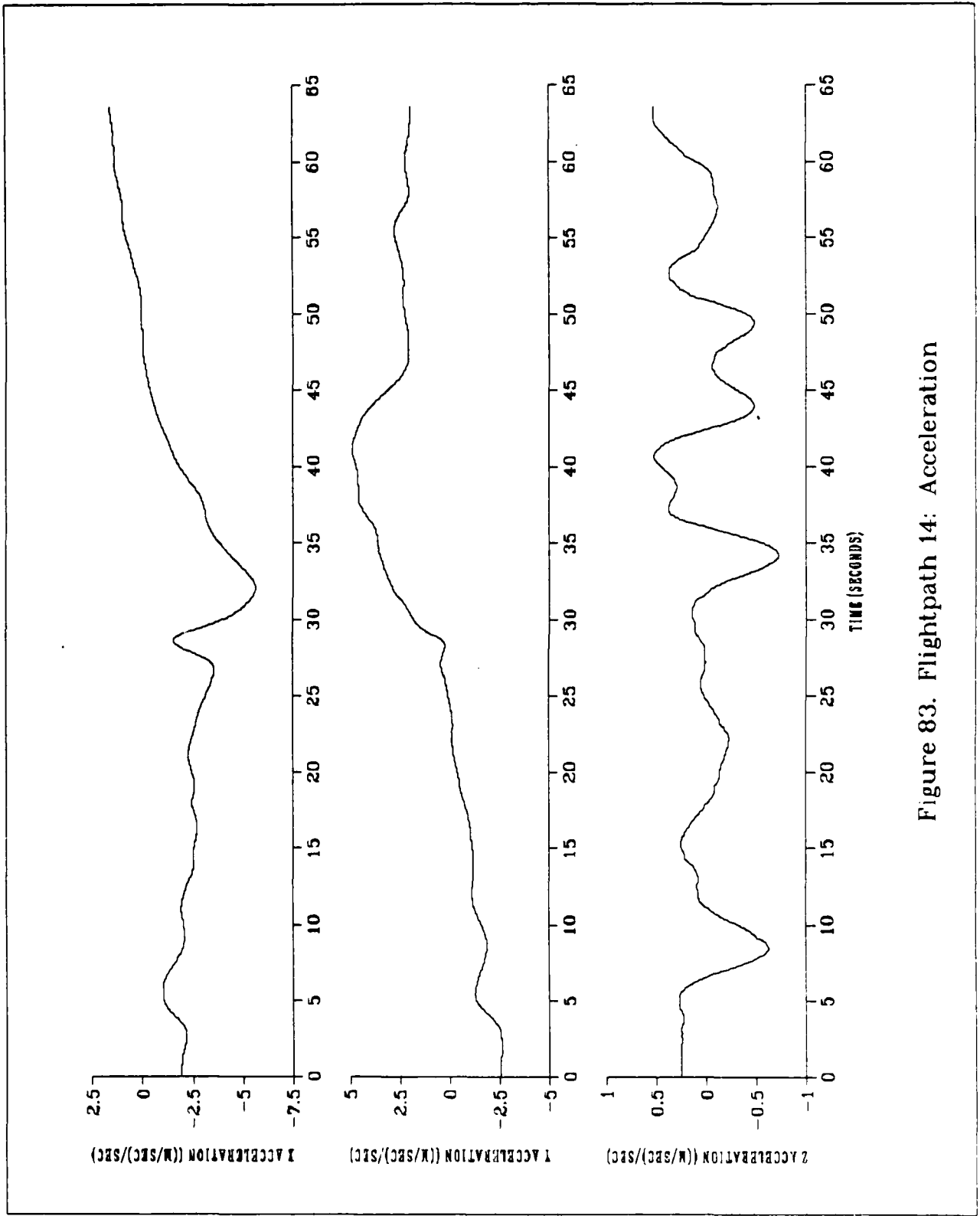

Figure 83. Flightpath 14: Acceleration

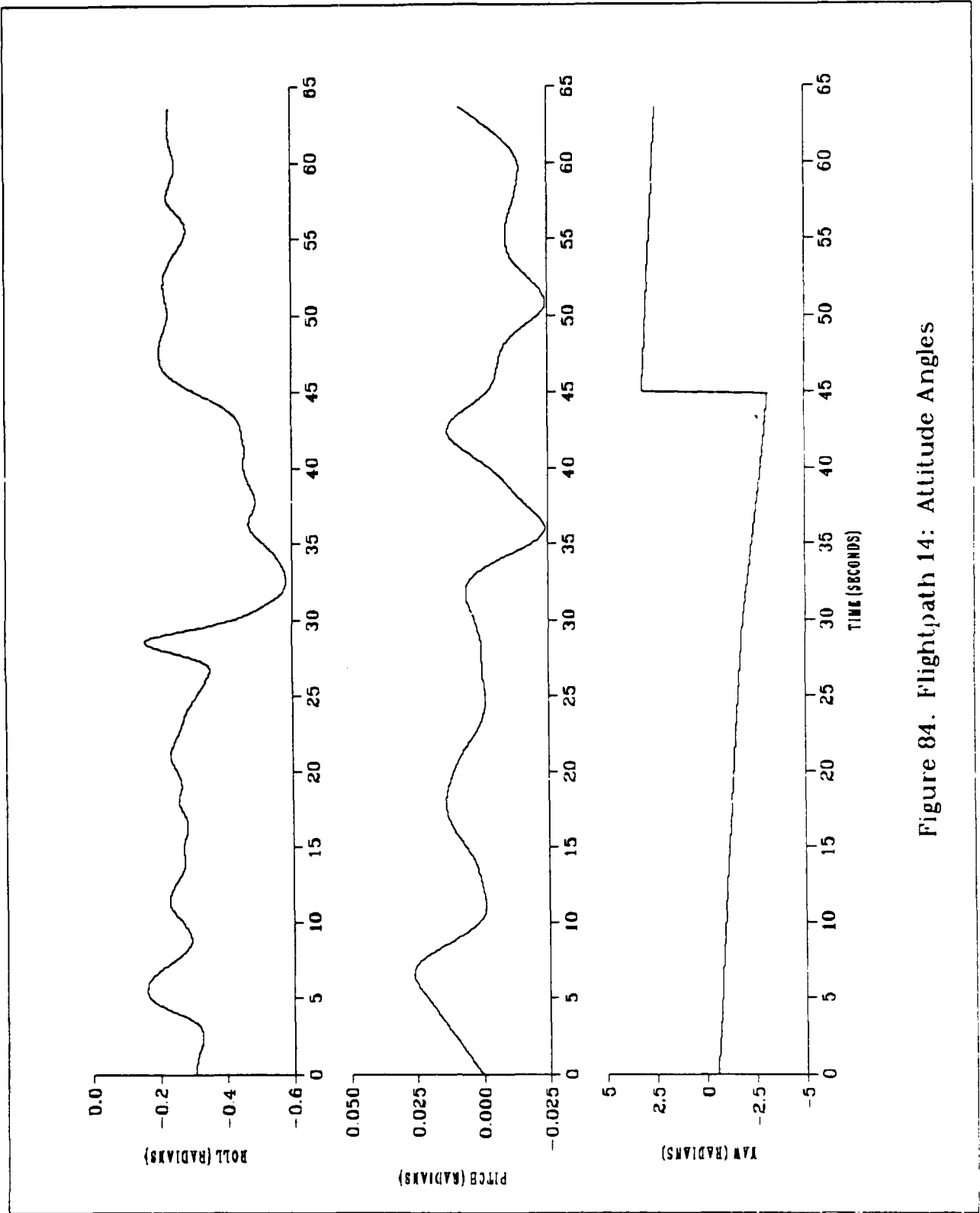

Figure 84. Flightpath 14: Attitude Angles

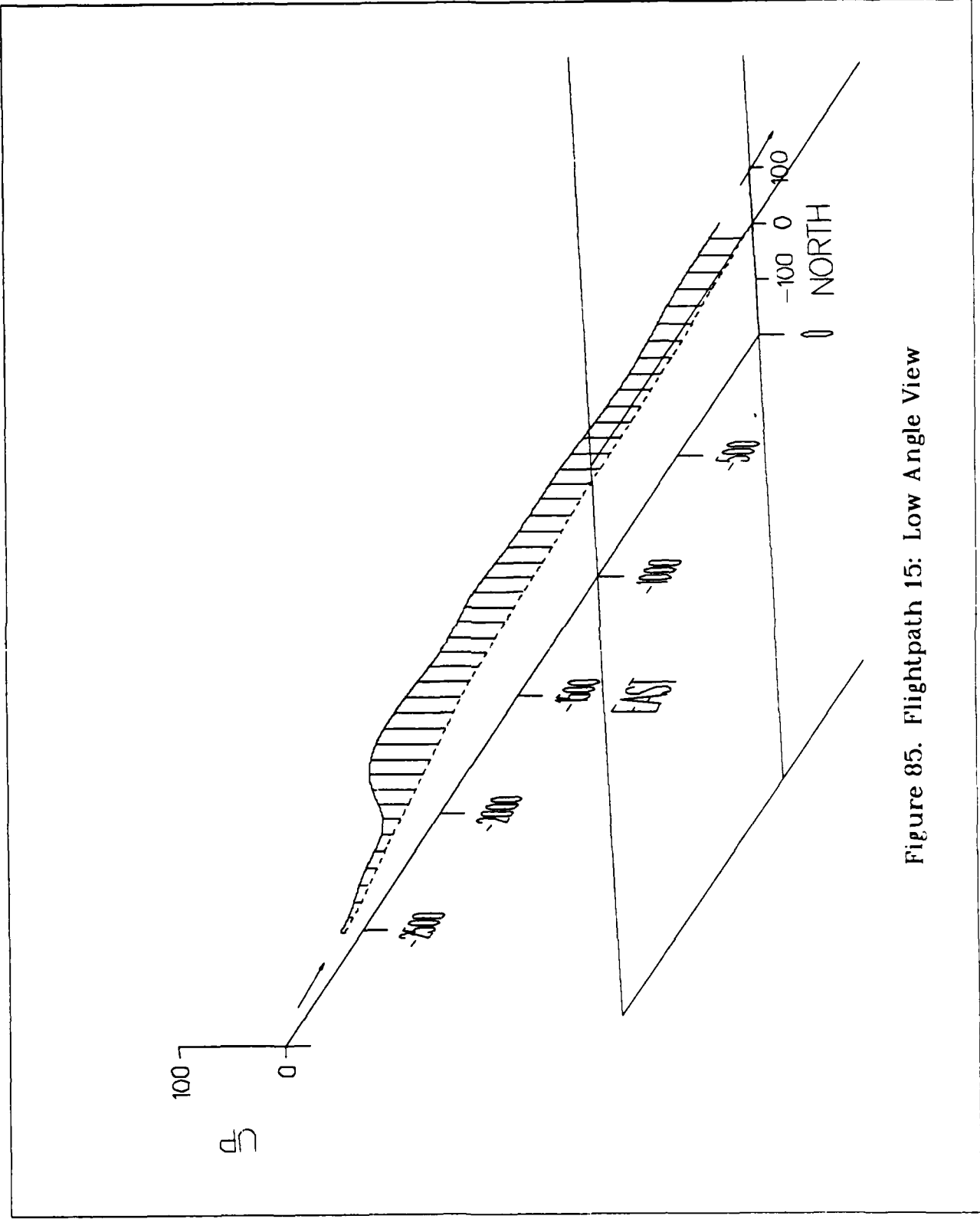

Figure 85. Flightpath 15: Low Angle View

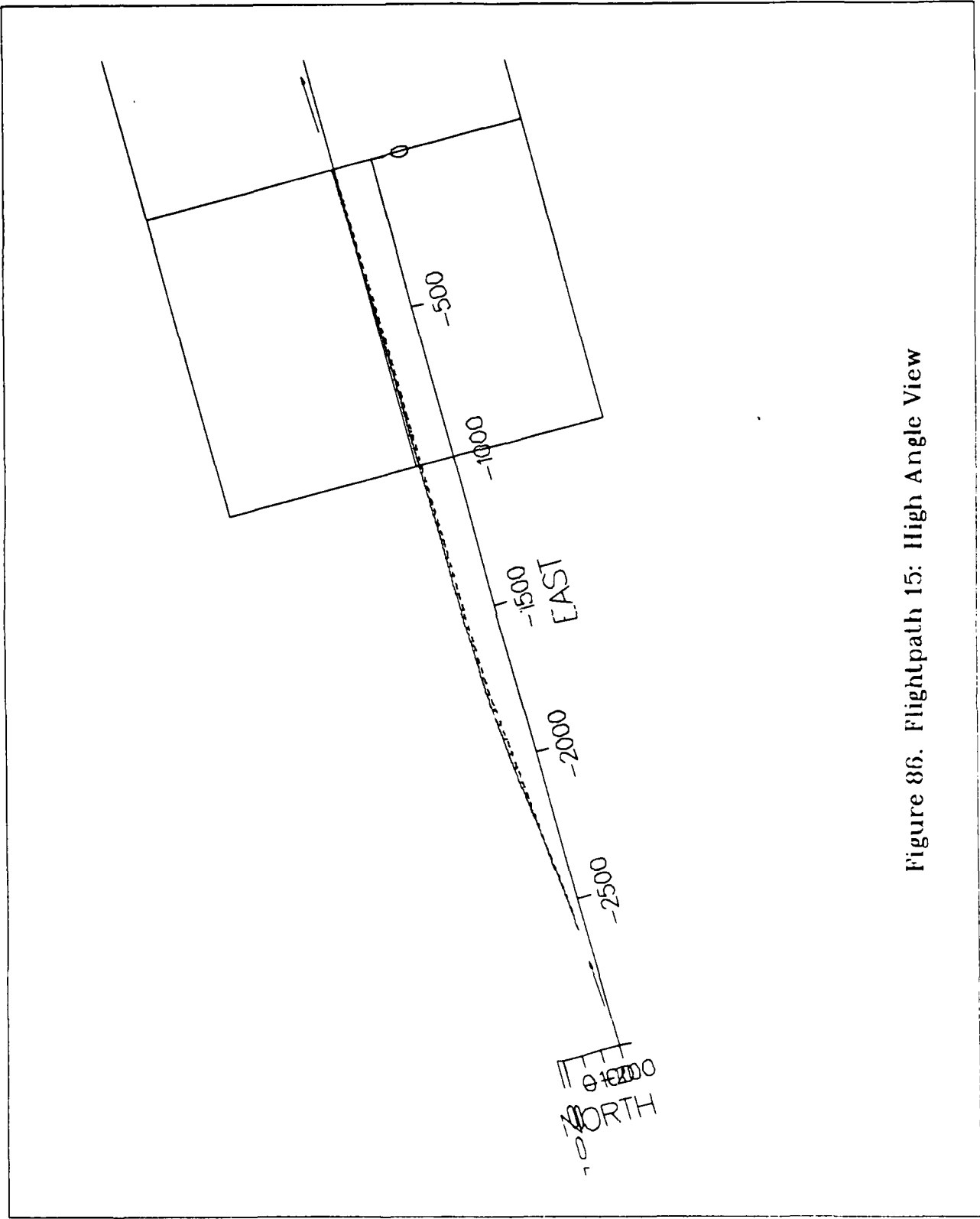

Figure 86. Flightpath 15: High Angle View

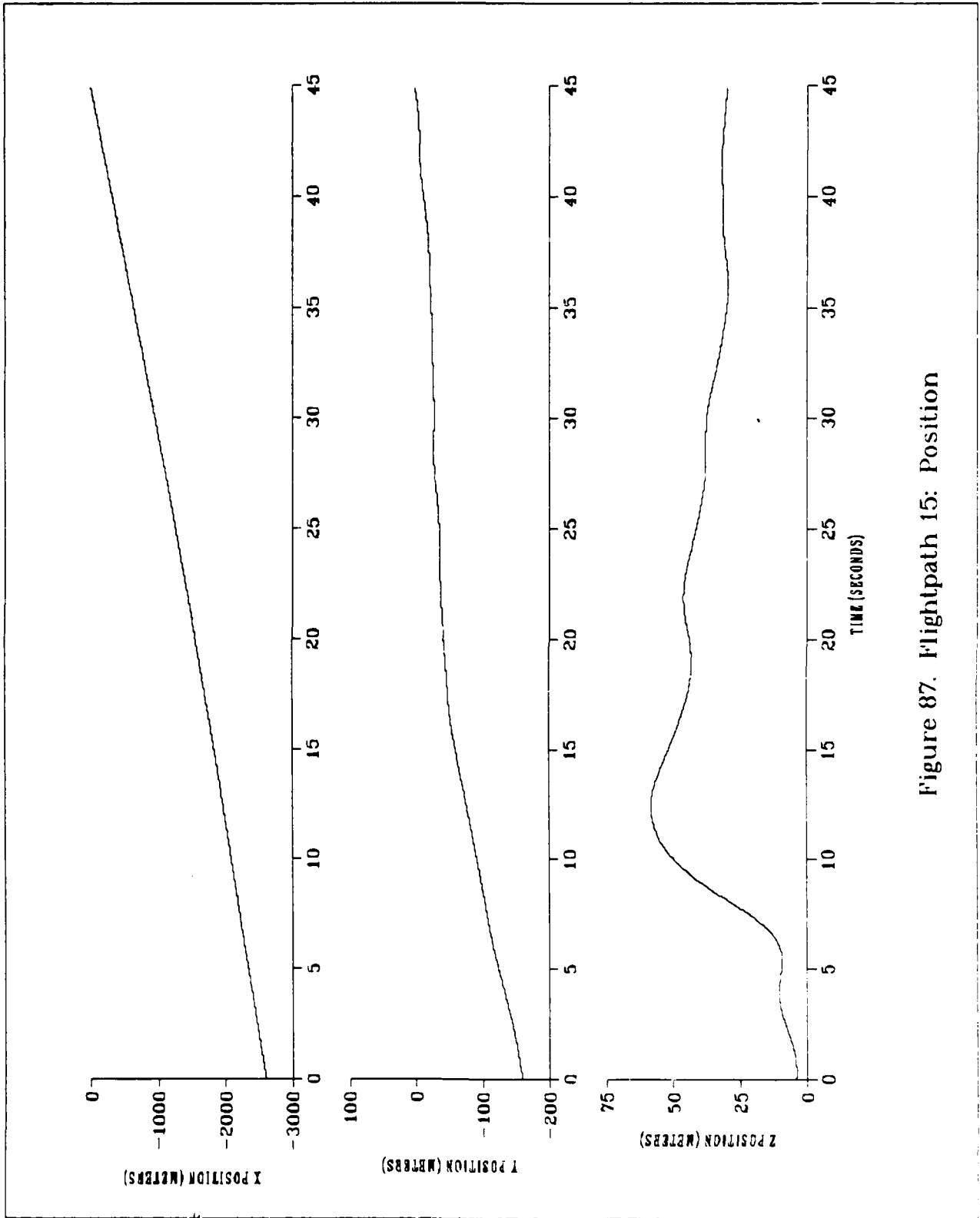

Figure 87. Flightpath 15: Position

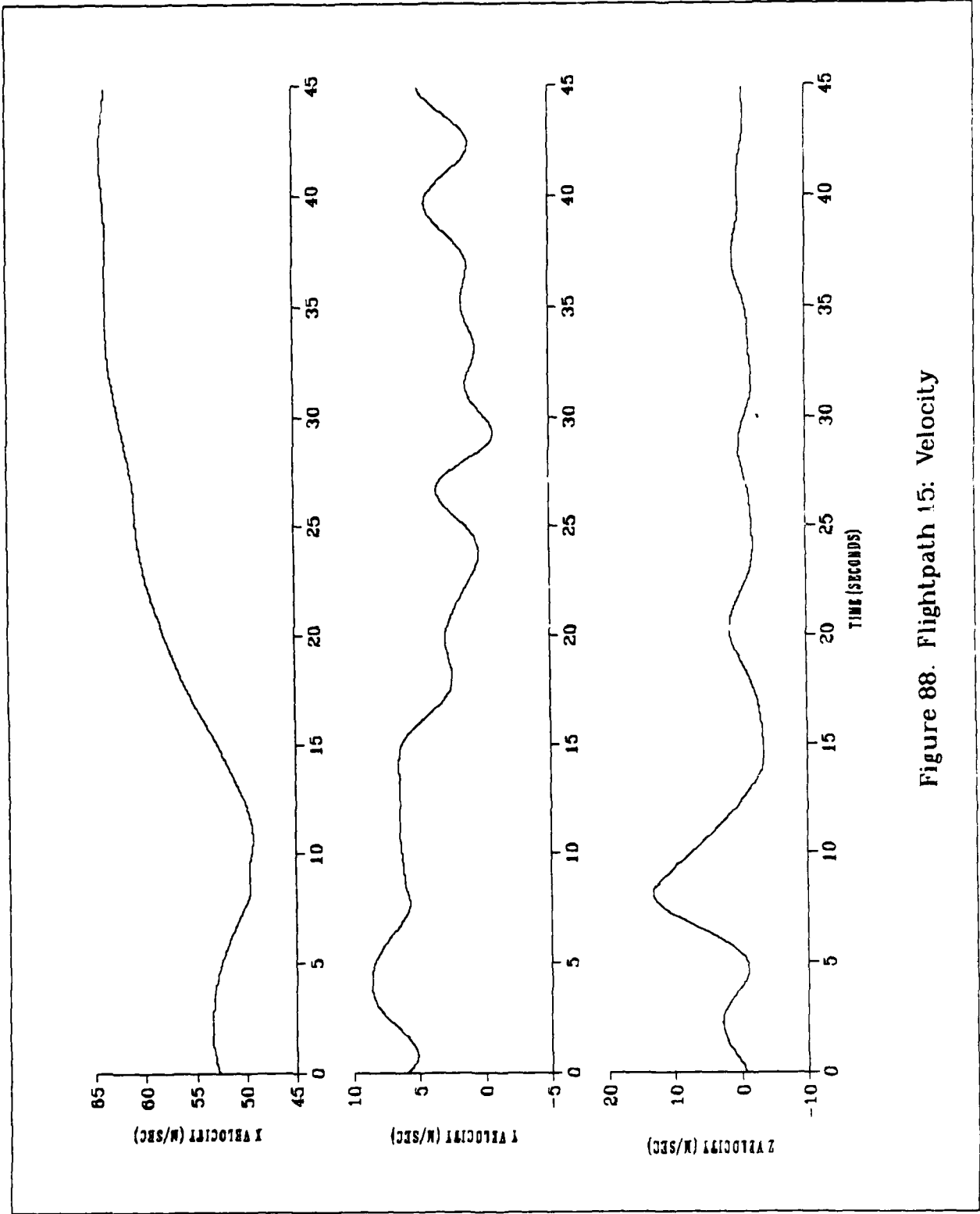

Figure 88. Flightpath 15: Velocity

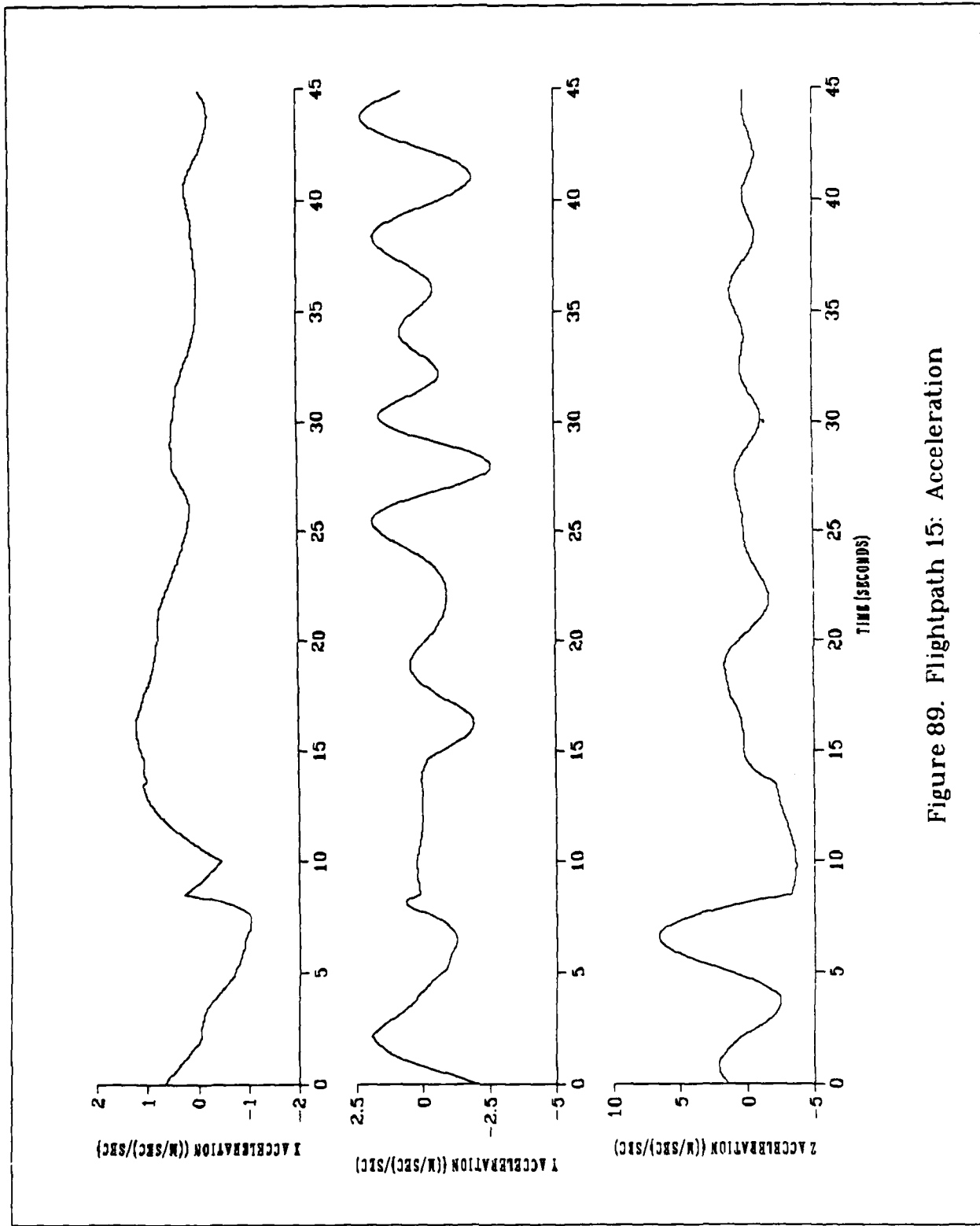

Figure 89. Flightpath 15: Acceleration

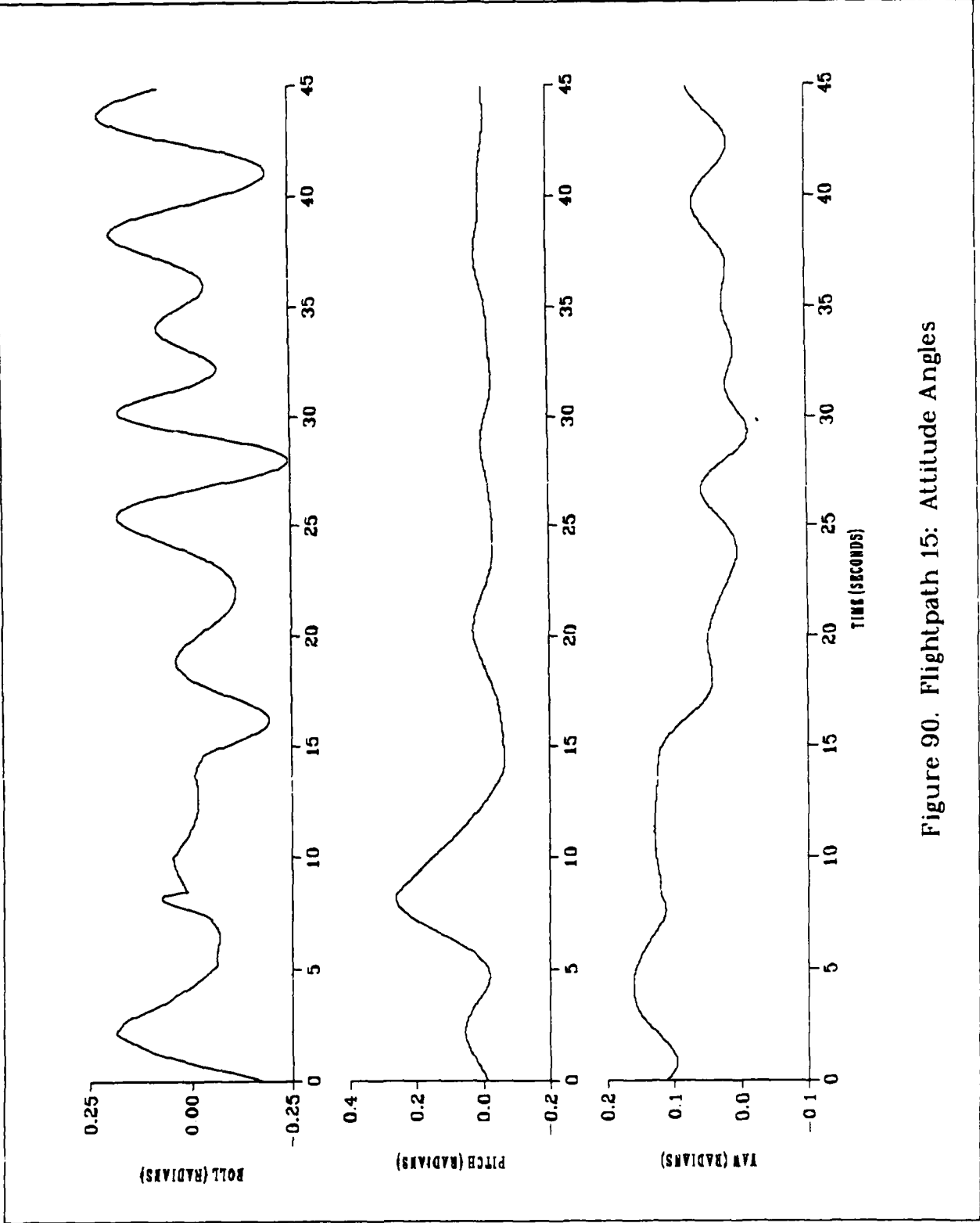

Figure 90. Flightpath 15: Attitude Angles

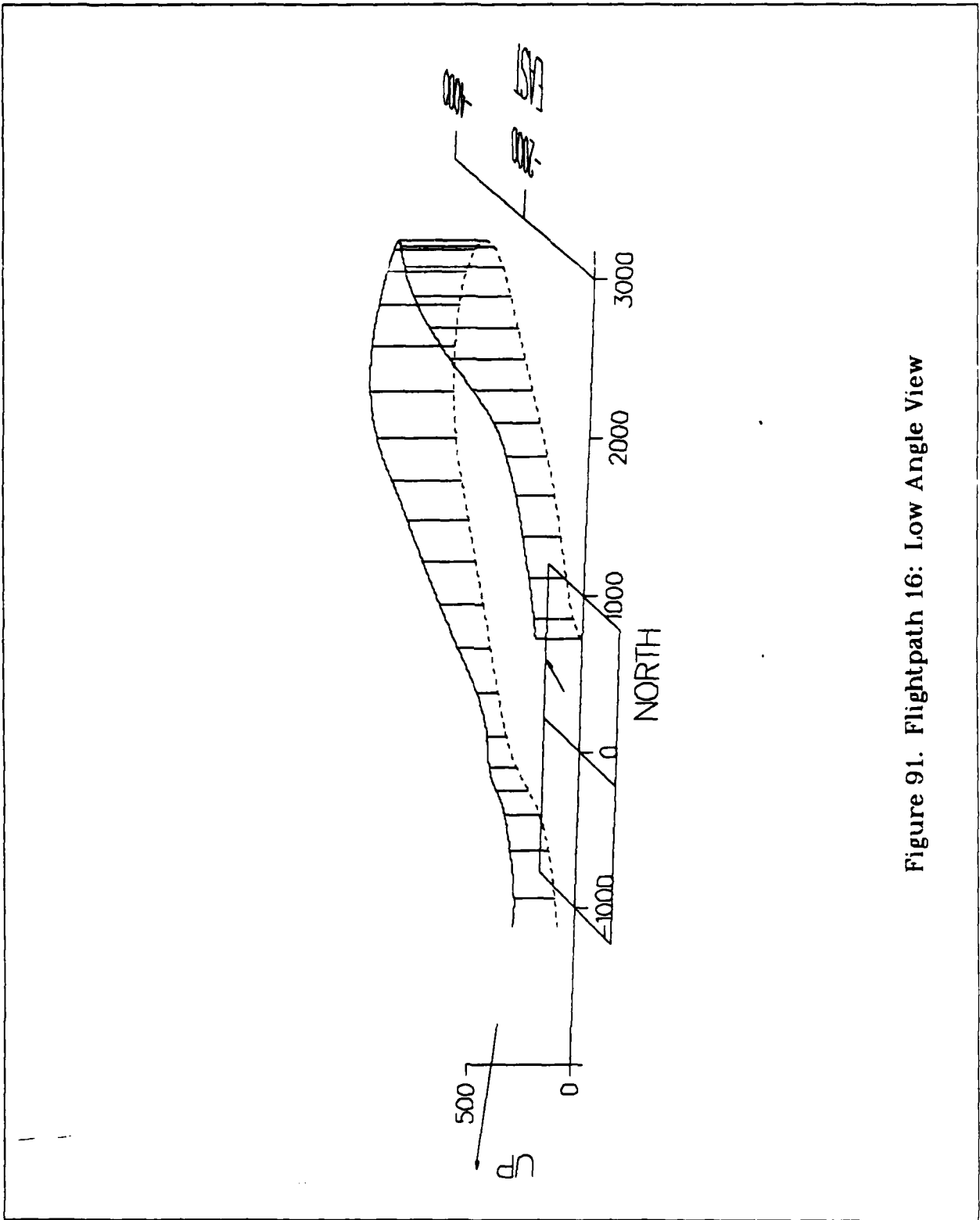

Figure 91. Flightpath 16: Low Angle View

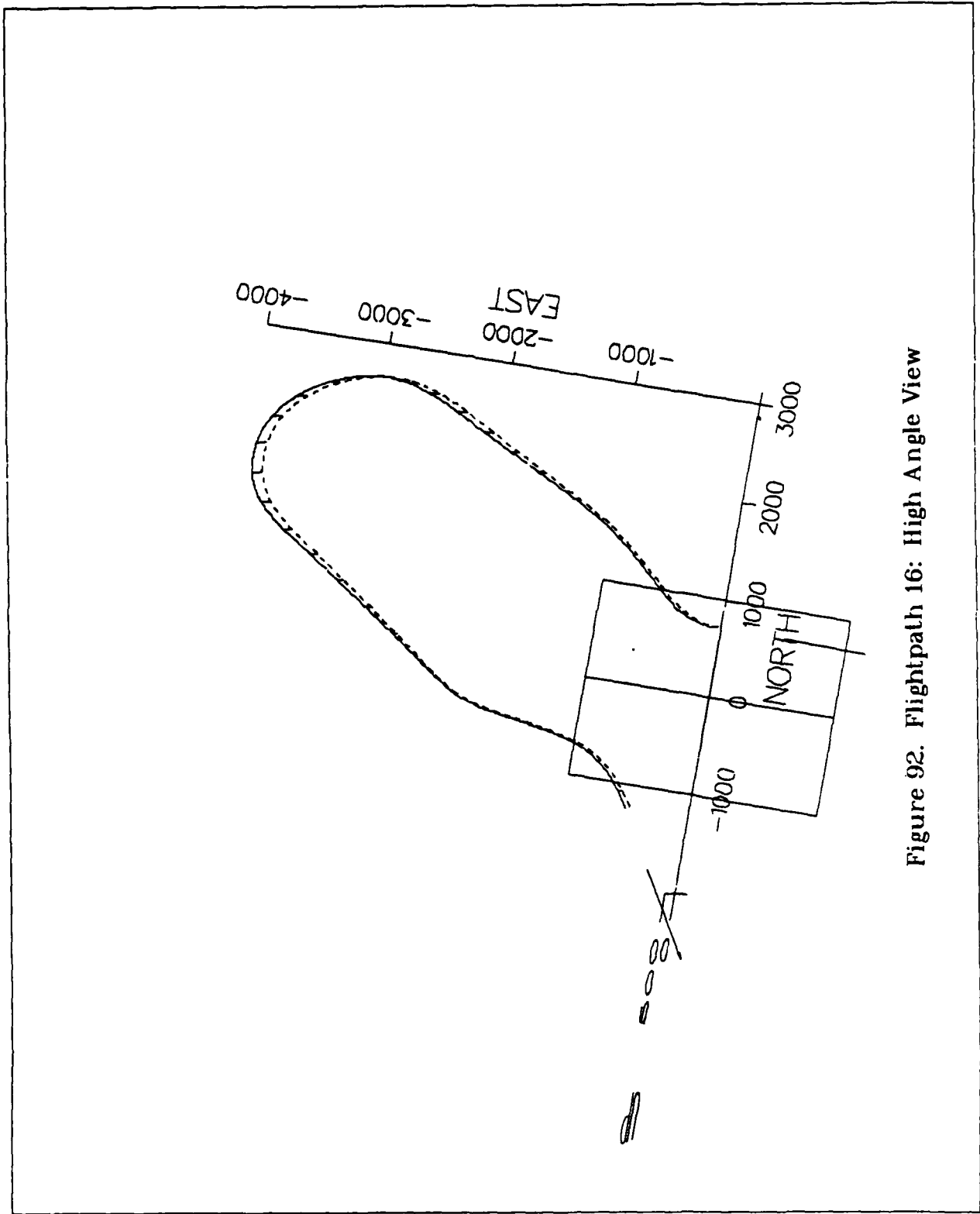

Figure 92. Flightpath 16: High Angle View

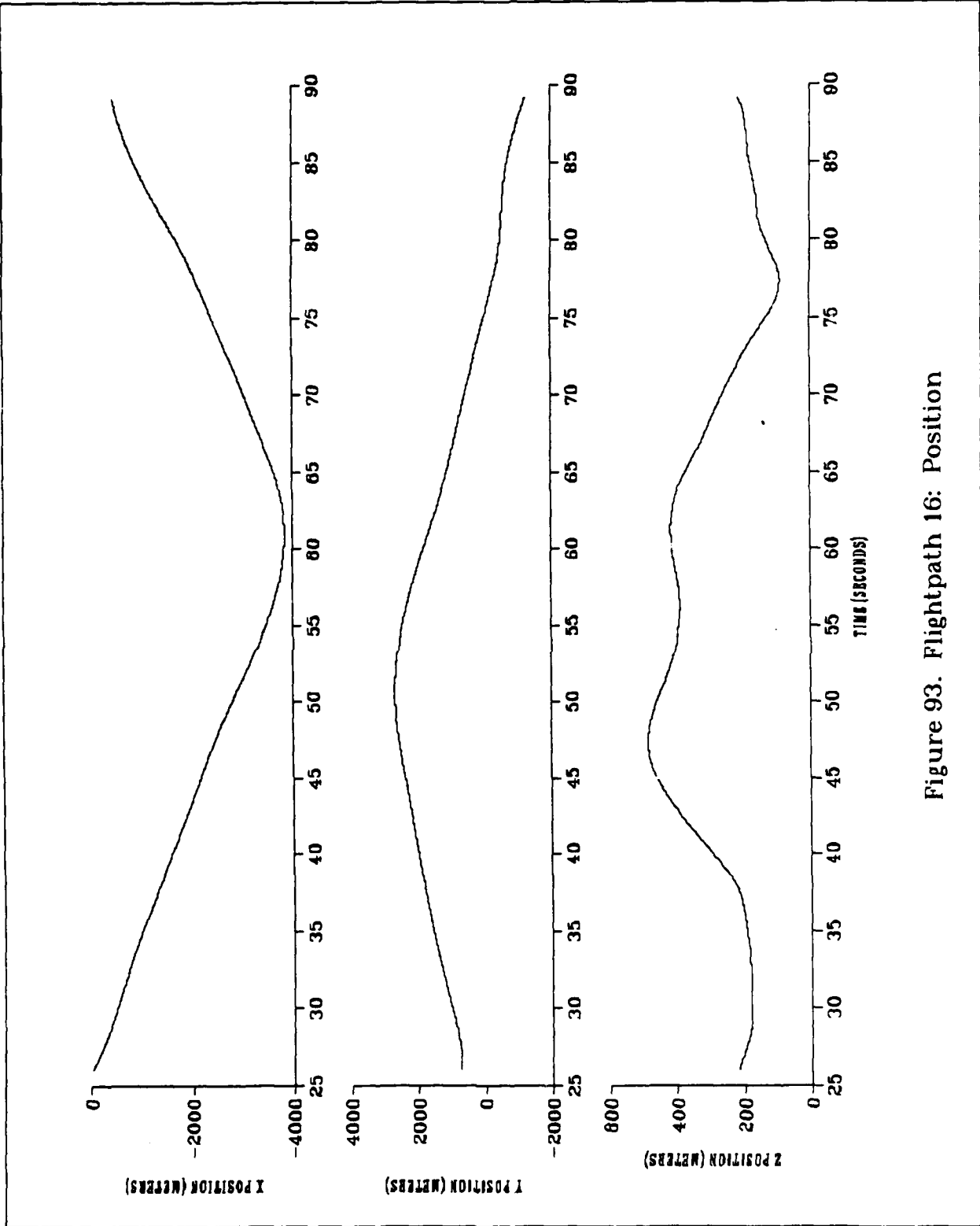

Figure 93. Flightpath 16: Position

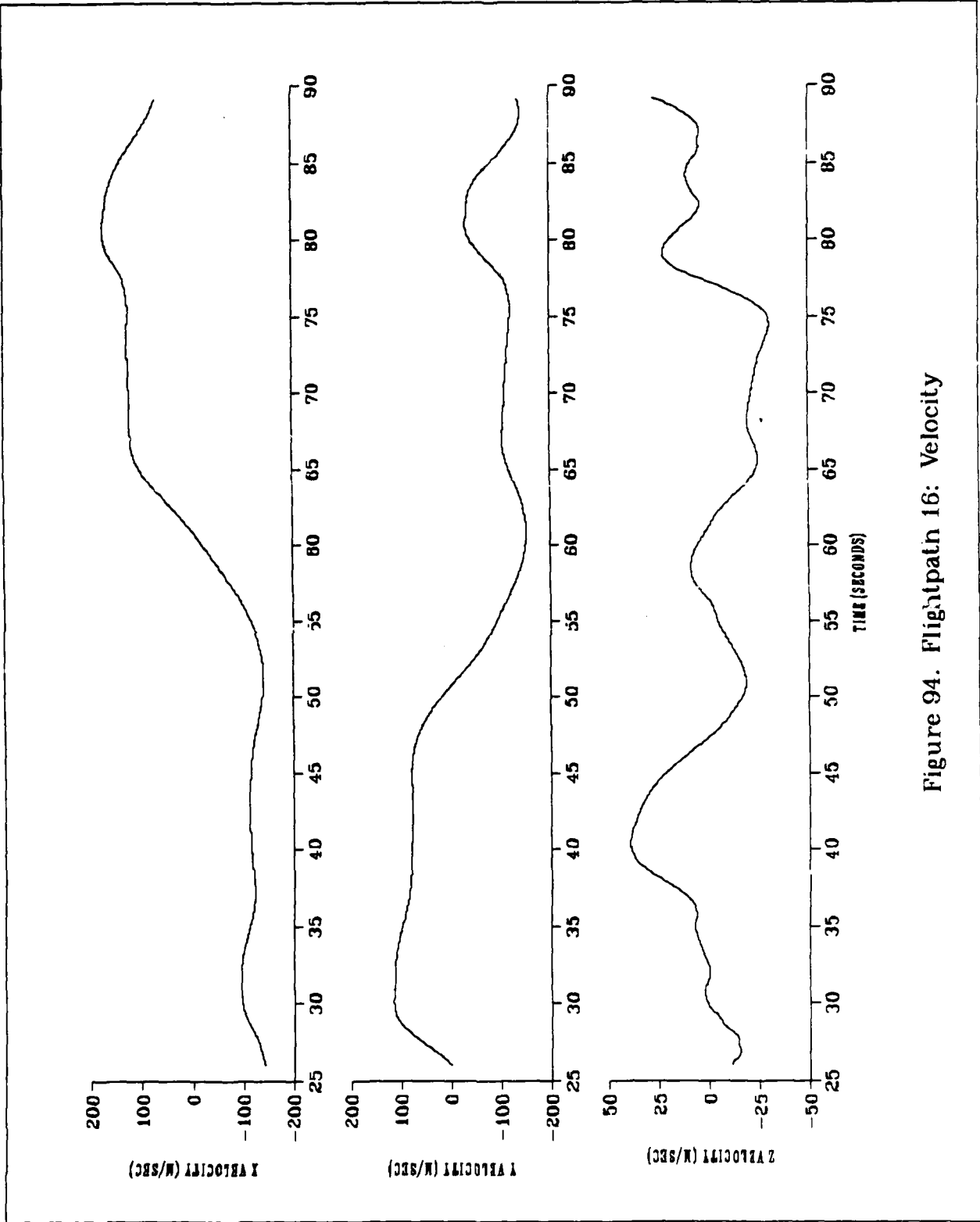

Figure 94. Flightpath 16: Velocity

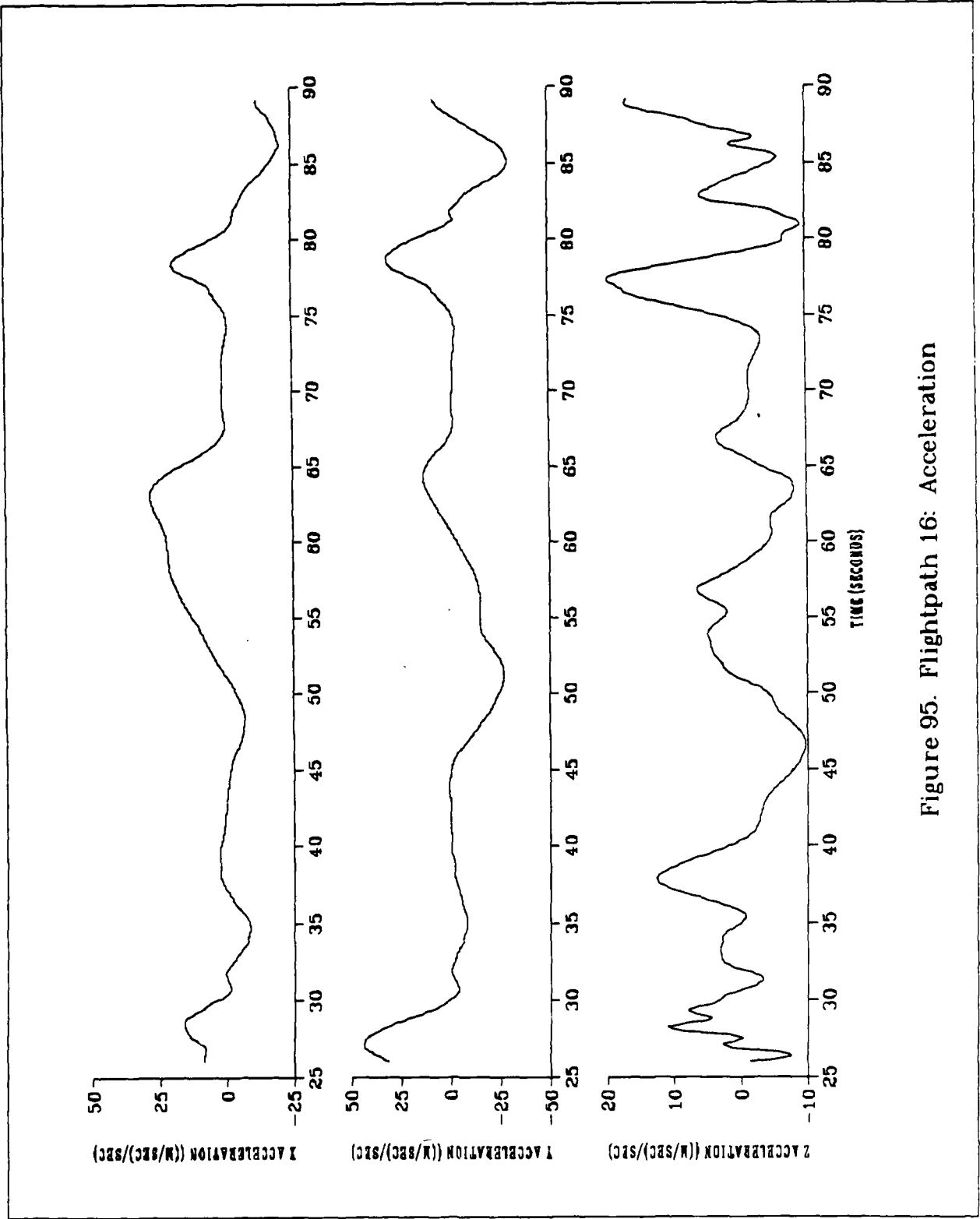

Figure 95. Flightpath 16: Acceleration

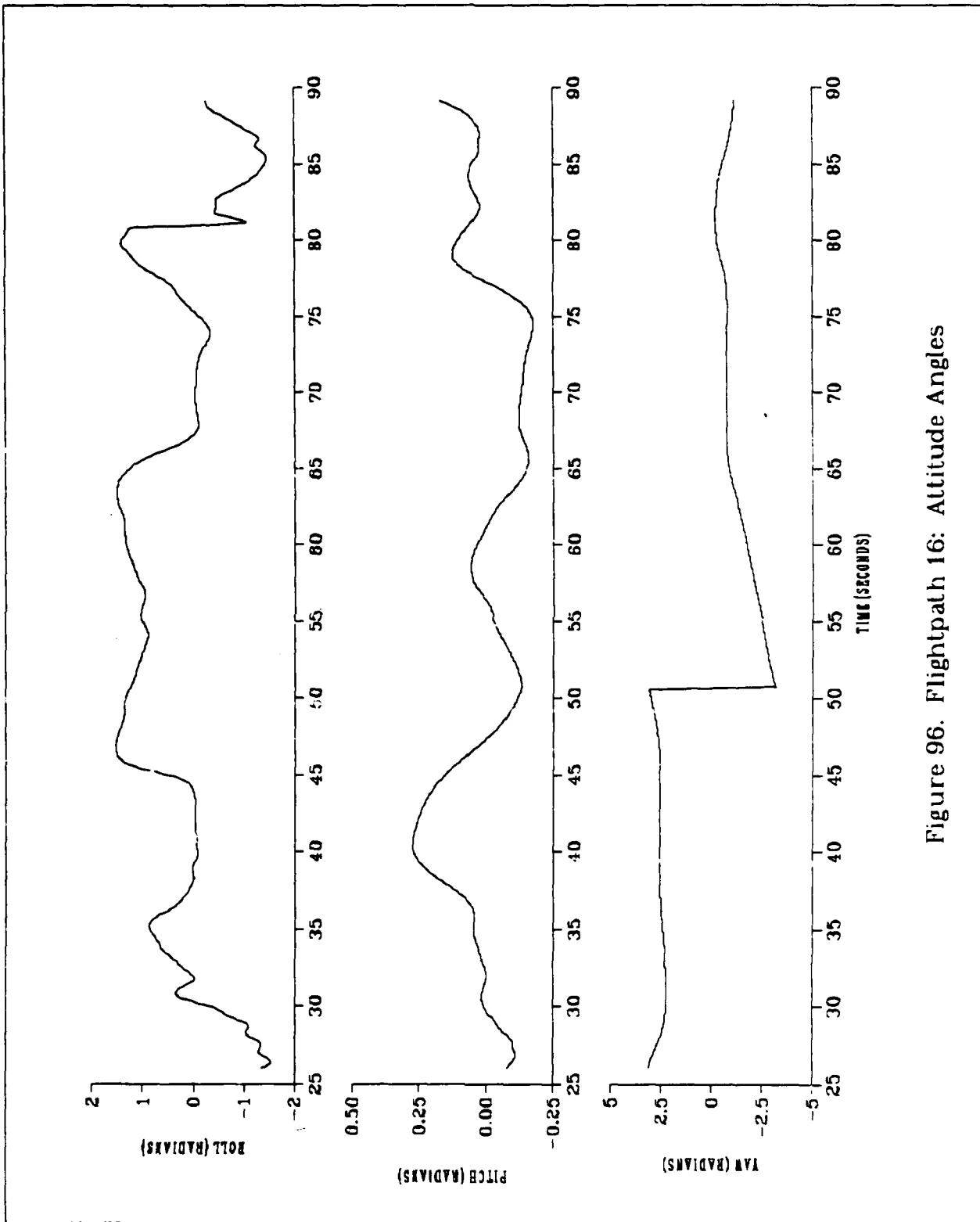

Figure 96. Flightpath 16: Attitude Angles

DISTRIBUTION LIST

<u>No. of Copies</u>	<u>Organization</u>	<u>No. of Copies</u>	<u>Organization</u>
12	Administrator Defense Technical Info Center ATTN: DTIC-DDA Cameron Station Alexandria, VA 22305-6145	1	Commander US Army Aviation Systems Command ATTN: AMSAV-DACL 4300 Goodfellow Blvd. St. Louis, MO 63120-1798
1	HQDA (SARD-TR) Washington, DC 20310-0001	1	Director US Army Aviation Research and Technology Activity Ames Research Center Moffett Field, CA 94035-1099
1	Commander US Army Materiel Command ATTN: AMCDRA-ST 5001 Eisenhower Avenue Alexandria, VA 22333-0001		
1	Commander US Army Laboratory Command ATTN: AMSLC-DL Adelphi, MD 20783-1145	2	Commander US Army Missile Command ATTN: AMSMI-AS Redstone Arsenal, AL 35898-5010
1	Commander Armament R&D Center US Army AMCCOM ATTN: SMCAR-MSI Picatinny Arsenal, NJ 07806-5000	1	Commander US Army Tank Automotive Command ATTN: AMSTA-TSL Warren, MI 48090-5000
1	Commander Armament R&D Center US Army AMCCOM ATTN: SMCAR-TDC Picatinny Arsenal, NJ 07806-5000	1	Director US Army TRADOC Analysis Command ATTN: ATAA-SL White Sands Missile Range, NM 88002
1	Director Benet Weapons Laboratory Armament R&D Center US Army AMCCOM ATTN: SMCAR-LCB-TL Watervliet, NY 12189-4050	1	Commandant US Army Infantry School ATTN: ATSH-CD-CSO-OR Fort Benning, GA 31905
1	Commander US Army Armament, Munitions and Chemical Command ATTN: SMCAR-ESP-L Rock Island, IL 61299-5000	1	AFWL/SUL Kirtland AFB, NM 87177
		1	Air Force Armament Laboratory ATTN: AFATL/DLODL Eglin AFB, FL 32542-5000

DISTRIBUTION LIST (Cont'd)

Aberdeen Proving Ground

Dir, USAMSAA

ATTN: AMXSY-D  
AMXSY-MP, H. Cohen  
AMXSY-AD (J. Meredith/C. Patterson  
D. Drake, C. Riley)

Cdr, USATECOM

ATTN: AMSTE-TO-F  
Cdr, CRDC, AMCCOM  
ATTN: SMCCR-RSP-A  
SMCCR-MU  
SMCCR-SPS-IL

USER EVALUATION SHEET/CHANGE OF ADDRESS

This laboratory undertakes a continuing effort to improve the quality of the reports it publishes. Your comments/answers below will aid us in our efforts.

1. Does this report satisfy a need? (Comment on purpose, related project, or other area of interest for which the report will be used.) \_\_\_\_\_  
\_\_\_\_\_
2. How, specifically, is the report being used? (Information source, design data, procedure, source of ideas, etc.) \_\_\_\_\_  
\_\_\_\_\_
3. Has the information in this report led to any quantitative savings as far as man-hours or dollars saved, operating costs avoided, or efficiencies achieved, etc? If so, please elaborate. \_\_\_\_\_  
\_\_\_\_\_
4. General Comments. What do you think should be changed to improve future reports? (Indicate changes to organization, technical content, format, etc.) \_\_\_\_\_  
\_\_\_\_\_

BRL Report Number \_\_\_\_\_ Division Symbol \_\_\_\_\_

Check here if desire to be removed from distribution list. \_\_\_\_\_

Check here for address change. \_\_\_\_\_

Current address: Organization \_\_\_\_\_  
Address \_\_\_\_\_  
\_\_\_\_\_

-----FOLD AND TAPE CLOSED-----

Director  
U.S. Army Ballistic Research Laboratory  
ATTN: SLCBR-DD-T (NEI)  
Aberdeen Proving Ground, MD 21005-5066



NO POSTAGE  
NECESSARY  
IF MAILED  
IN THE  
UNITED STATES

OFFICIAL BUSINESS  
PENALTY FOR PRIVATE USE \$300

**BUSINESS REPLY LABEL**  
FIRST CLASS PERMIT NO. 12062 WASHINGTON D. C.

POSTAGE WILL BE PAID BY DEPARTMENT OF THE ARMY

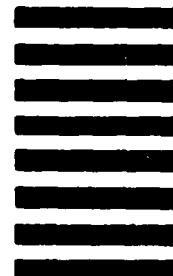

Director  
U.S. Army Ballistic Research Laboratory  
ATTN: SLCBR-DD-T (NEI)  
Aberdeen Proving Ground, MD 21005-9989