

AD-A210 369

4
COPY

| | | | |
|--|--|--|--|
| 2. GOVT ACCESSION NO. | | 3. RECIPIENT'S CATALOG NUMBER DTIC FILE | |
| 4. TITLE (and Subtitle) Establishment and Initial Operation of a Resource Facility for RSR Processed Alloys in Pilot Quantities | | 5. TYPE OF REPORT & PERIOD COVERED Final 9/30 /1980 to 9/30/1983 | |
| 7. AUTHOR(s) B.C. Giessen | | 6. PERFORMING ORG. REPORT NUMBER | |
| 9. PERFORMING ORGANIZATION NAME AND ADDRESS Northeastern University 360 Huntington Ave., 341 MU Boston, MA 02115 | | 8. CONTRACT OR GRANT NUMBER(s) N00014-80-C - 0986 | |
| 11. CONTROLLING OFFICE NAME AND ADDRESS Director, Metallurgy Program, Materials Sci. Div. Office of Naval Research, Code 431 800 N. Quincy St., Arlington, VA 22217 | | 10. PROGRAM ELEMENT, PROJECT, TASK AREA & WORK UNIT NUMBERS NR 039-212 (Code 431) | |
| 14. MONITORING AGENCY NAME & ADDRESS (if different from Controlling Office) | | 12. REPORT DATE 6/22/1989 | |
| | | 13. NUMBER OF PAGES | |
| | | 15. SECURITY CLASS. (of this report) Unclassified | |
| | | 15a. DECLASSIFICATION/DOWNGRADING SCHEDULE | |
| 16. DISTRIBUTION STATEMENT (of this Report) Reproduction in whole or in part is permitted for any purpose of the United States Government. Distribution of this document is unlimited. | | | |
| 17. DISTRIBUTION STATEMENT (of the abstract entered in Block 20, if different from Report) | | | |
| 18. SUPPLEMENTARY NOTES | | | |
| 19. KEY WORDS (Continue on reverse side, if necessary, and identify by block number) Rapid Solidification Rate (RSR), Rapid Solidification Processing (RSP), Alloy Processing, Melt Spinning, Powder Metallurgy, Metal Powder Preparation, Metallic Glasses. | | | |
| 20. ABSTRACT (Continue on reverse side if necessary and identify by block number) The program objective was to construct and operate a rapid solidification rate (RSR) processing resource facility based on melt spinning of pilot scale quantities. It consists of a controlled-atmosphere melt spinner with a capacity of 1 lb of ferrous alloy, a 100 g capacity melt spinner (to establish experimental parameters and reduce cross-contamination), and a high-speed ribbon cutter for flake preparation. RSR processed materials were delivered to Government, industrial and academic users. | | | |

DTIC
ELECTE
JUL 14 1989
S E D

DD FORM 1 JAN 73 1473

Unclassified

SECURITY CLASSIFICATION OF THIS PAGE (When Data Entered)

88

173

Report Number: N 00014-80-0986-2

Final Report



| | |
|--------------------|-------------------------------------|
| Accession For | |
| NTIS GRA&I | <input checked="" type="checkbox"/> |
| DTIC TAB | <input type="checkbox"/> |
| Unannounced | <input type="checkbox"/> |
| Justification | |
| By _____ | |
| Distribution/ | |
| Availability Codes | |
| Dist | Avail and/or Special |
| A1 | |

to
Defense Advanced Research Project Administration
and
Office of Naval Research

Contract N 00014-80-C-0986

Establishment and Initial Operation of a Resource Facility
for
RSR Processed Alloys in Pilot Quantities

B.C. Giessen
Materials Science Division
Barnett Institute of Chemical Analysis and Materials Science
Northeastern University
Boston, Massachusetts 02115

June 1989

Reproduction in whole or in part is permitted for any purpose of the United States Government. Distribution of this document is unlimited.

I. TECHNICAL BACKGROUND

The technique of rapid solidification rate (RSR) processing has been applied in the past 15 years to many alloys spanning the spectrum of materials of interest in modern alloy development work, including alloys based on iron, nickel, copper, aluminium, and others.¹⁻⁶ Appropriate equipment is required to obtain RSR processed materials in reliable and reproducible form. At the time of initiation of this program, such equipment was not available commercially and many laboratories interested in research on these materials did not have the required facilities.

The present program was proposed and undertaken to provide the metallurgical research community in industry, government and academia with a non-commercial source of RSR processed material, especially in particulate form or other form usable as a precursor to bulk material preparation, and in pilot research quantities (1-10 lbs), as required for further processing and testing.

Two principal approaches were then in use and are now being utilized to produce rapidly solidified powder or particulate materials. Both are based on the fact that the required conditions of rapid heat extraction can only be achieved if at least one materials dimension is kept small, of the order of 25-100 μm .

In one method, RSR processed alloy powders are produced directly from the melt; droplets are obtained by spray atomization or other, similar methods and are quenched during the solidification process by forced gas cooling, quenching liquids, or by impingement on a solid heat extracting substrate. Some advantages of this method are the ability to utilize existing atomization technology and a large throughput; however, disadvantages are that the cooling rates do not exceed $10^4 - 10^5$ K/ sec for high volume processed and that each particle has a different quenching history and hence, frequently, a different microstructure.

These difficulties are avoided by an alternative method, viz., melt spinning of liquid alloy into rapidly quenched ribbons, followed either by direct consolidation of ribbons into bulk shapes or, where possible, pulverization with subsequent consolidation. Advantages of this method are the higher cooling rate (10^5 - 10^6 K/sec) and the identical quenching history of all parts of the RSR processed material (disregarding small variations in cooling rate between the "top" and the "wheel" side of the resulting ribbons). This method is also capable of high throughput and productivity. A drawback (from the powder metallurgical viewpoint) is that only metals possessing sufficient brittleness for pulverization can be prepared readily as roughly equiaxed powders in this way; other alloys must either be consolidated in coiled or tangled ribbon form or must be otherwise pre-processed, e.g., by cutting into small ribbon segments.

At the time of initiation of this program, the existing capacities for RSR processing by atomization were insufficient to meet the varied demand for services and there were no facilities for RSR toll processing available to researchers that intended to utilize the melt spinning approach.

II. PROGRAM OBJECTIVES AND TASKS

With the considerations presented above in mind, an RSR processing facility has been planned and established, utilizing melt spinning in controlled atmosphere. The need to process different types of materials suggested that it would be desirable to have two individual units in the facility which could be dedicated to different projects. Further, as discussed above, there was a need to convert ribbon material to particulates; for this purpose two avenues were pursued: first, a bantam scale mechanical pulverizer was acquired and installed, and, second, a ribbon chopper was designed and constructed. An arc furnace was installed for alloy premelting, especially for alloys containing refractory metals. After assembly, the system was operated as a service facility. The program thus had four tasks:

1. Construction of a Small Capacity Melt Spinning System: This system, with a capacity of about 100 to 250 g of ferrous alloy, was built to be used to establish experimental parameters and to be maintained as an alternative system that would be available when needed (a) to improve housekeeping by reducing the possibility for cross-contamination with different metals and (b) for small-scale services. To reduce cost, this unit has been built from existing components.

2. Construction of the Principal (Pilot-Scale) Melt Spinning System: This system, with a capacity of about 500 g of ferrous alloy, has been designed to operate within a controlled atmosphere chamber for alloy protection and to facilitate material collection. The heart of the system is a 1 1/2' diameter, 2" wide, water-cooled copper wheel with a brush stand. Pictures showing the system are appended (below). Both systems are powered by a 15 kW Pillar RF induction power supply.

3. Construction of Ribbon Copper: The ribbon chopper designed and constructed under this program is described extensively in a letter published in Mater. Lett. (Ref. 7) which is presented as Appendix I; reference is made here to that description.

4. Operation of RSR Processing Resource Facility: This task included RSR processing of materials that either were supplied by Government laboratories and academic and industrial laboratories working under Government contract or were premelted here following the specifications of these organizations.

Availability of the resource facility for this purpose was advertised; descriptions of capability and quotes for available services were made, as shown in the appended sample brochure material (Appendix II).

III. DESIGN, CONSTRUCTION AND DESCRIPTION OF
RSR RESOURCE FACILITY

1. Small-to-Medium Scale Melt Spinner: As mentioned, this unit has been designed based essentially on existing components, combining an existing melt spinning system (Cu wheel and motor assembly) with an existing large, box-shaped vacuum (protective atmosphere) chamber. The unit was then assembled from these and other components and put into service. This system, like the one described next, uses the 15 kW Pillar RF power supply acquired under this program as a heating energy source and depends on the performance of this power supply. The Pillar unit was not delivered and operational until June, 1982.
2. Pilot-Scale Melt Spinner: The pilot scale melt spinner has a materials capacity of about 500 g of Fe or Ni-based alloy per run and is incorporated into a protective atmosphere chamber. It has been designed and built along the lines sketched in the original proposal and is illustrated here by reference to the perspective drawing (Fig. 1) and the photographs given in Figures 2 - 8, which show the unit from different perspectives and, taken together with Fig. 1, are essentially self-explanatory.

Note in Figs. 1 and 5 the brush mechanism used to clean the wheel during spinning and, in Figs. 1 and 6, the gloves used to package and seal melt spun material into a plastic bag after production, without breaking the inert gas atmosphere. Note also in Figs. 1 and 2 the rectangular crucible chamber of top of the main vacuum tank, shown in close-up in Fig. 8, containing the crucible position adjustment mechanism. The induction power supply acquired under this program is shown in Fig. 9. Fig. 10 shows a schematic drawing of the high-speed chopper designed and built for the preparation of flakes from melt spun ribbons (Ref. 7).

Some further details of the system are as follows:

The protective chamber is cylindrical, 2 1/2' dia x 5' long, stainless steel (1/8" thick), with three access ports, a pair of glove ports, one fully hinged rear door (2 1/2' dia), one hinged front door (1' dia) and a cube shaped top chamber (1' x 1' x 1') for crucible mounting and sample charging.

The alloy melting unit consists of a crucible position adjustment stage and a crucible adaptor.

The spinning unit consists of a water cooled copper wheel (1 1/2' dia x 2" thick) with wheel supporter, brush stand and D.C. motor (2 HP, with variable speed controller).

Other parts and associated equipment include:

A mechanical vacuum pump (30 cfm);

a 15 kW Pillar RF induction power supply;

an arc melting furnace with button flipper, 7-pot water cooled hearth, 40 kW DC power supply, diffusion pump and automatic pumping system;

a mechanical pulverizer (bantam scale).

3. Capabilities of RSR Facility: The small scale unit described above is capable of a production volume of 0.5-1 lb of ferrous alloy per day with three to four runs per day in inert atmosphere; if operated in air it has a considerably shorter recycling time and hence larger capacity.

The pilot scale unit has a capacity of about 2 lb of ferrous alloy per day in closed system operation; for lower density materials such as Al alloys, both units will have correspondingly smaller mass throughputs.

Comminution of brittle RSR produced ribbons subsequent to spinning can be carried out by the mechanical pulverizer acquired under the present program. This pulverizer has a powder making capacity of 25-100 lb. per hr, depending upon the material and a rated yield of 80 percent at 100 mesh, exceeding the rate of materials preparation by melt spinning.

Ductile alloys can be processed with the high speed chopper mentioned above which can produce flakes of 1 mm length from 1 mm wide ribbon material.

Special alloys which require arc furnace melting prior to spinning (such as ferrous alloys containing refractory elements) can be pre-processed with the arc melting furnace. Others can be pre-melted by induction melting using the induction furnace that is a part of each melt spinner.

4. Operation of RSR Facility and Alloy Processing Service: We have announced the availability of the RSR processing service at appropriate scientific or information meetings such as the Briefing/Workshop on Rapid Solidification Technology at NBS, July 1981 and the Symposium on Rapidly Solidified Metals at the MRS Conference in Boston, November 1981. Inquiries and requests were thereupon received from a number of government laboratories, firms and academic labs. Appendix II presents a typical quote for services supplied in response to an inquiry for preparation of RSP processed superalloys to be included into a proposal for government sponsorship.

Over the course of the program, services were performed for (at least) 13 qualifying organizations. These included eight industrial firms (among them seven major, national companies, and one small firm), four government laboratories (AF Wright Aeronautical Lab, ARADCOM, Los Alamos National Lab, Sandia National Lab) and two universities (MIT, Stanford).

Two comments should be made on the operational aspects of this project. First, early in the service program, we were informed by a corporation of their proprietary rights to a specific ribbon preparation process, their business conditions for granting a licence for use of this process in toll processing, and, in the absence of such a licence, the technical conditions to be met by our process to avoid possible infringement. Accordingly, we had to restrict the services rendered to melt spinning practiced in such a way as to avoid any possible infringement.

Second, during the lifetime of the program, commercial melt spinning systems became available, especially a low-cost, chamber-enclosed unit that was subsequently acquired by several organizations that might otherwise have turned to us for melt spinning services.

5. Summary and Status: Summarizing, the facility has served and continues to serve a useful research function for many projects; it is and remains available for use by the research community for which it was established.

REFERENCES

1. B.C. Giessen, B.H. Kear, and M. Cohen, Eds., Rapidly Solidified Amorphous and Crystalline Alloys, Mater. Res. Soc. Symp. Proc., Vol. 8, North-Holland, N.Y. (1982).
2. T. Masumoto and K. Suzuki, Eds., Proc. Fourth International Conference on Rapidly Quenched Metals, Sendai, (1981), The Japan Institute of Metals, Sendai, Japan, (1982).
3. B.H. Kear and B.C. Giessen, Eds., Rapidly Solidified Metastable Materials, Mater. Res. Soc. Symp. Proc. Vol. 28, North-Holland, N.Y. (1984).
4. S. Steeb and H. Warlimont, Eds., Rapidly Quenched Metals, Proc. Fifth Intern. Conf. on Rapidly Quenched Metals (RQ5), Wurzburg, Germany, North-Holland, Amsterdam, (1985).
5. B.C. Giessen, D.E. Polk, and A.I. Taub, Eds., Rapidly Solidified Alloys and their Mechanical and Magnetic Properties, Mater. Res. Soc. Symp. Proc. Vol. 58, MRS, Pittsburgh, PA (1986).
6. R.W. Cochrane and J.O. Strom-Olsen, Eds., Rapidly Quenched Metals 6, Proc. RQ6 Conference, Montreal, Canada, August 1987, Mater. Sci. Eng., Vol. 97-99 (1988) and Elsevier Applied Science, London and NY (1988).
7. S.H. Whang and B.C. Giessen, "P/M Flake Material Prepared by Mechanical Chopping of Rapidly Quenched Metallic Ribbon", Mater. Lett. 2, 230 (1984).

PILOT SCALE MELT SPINNER

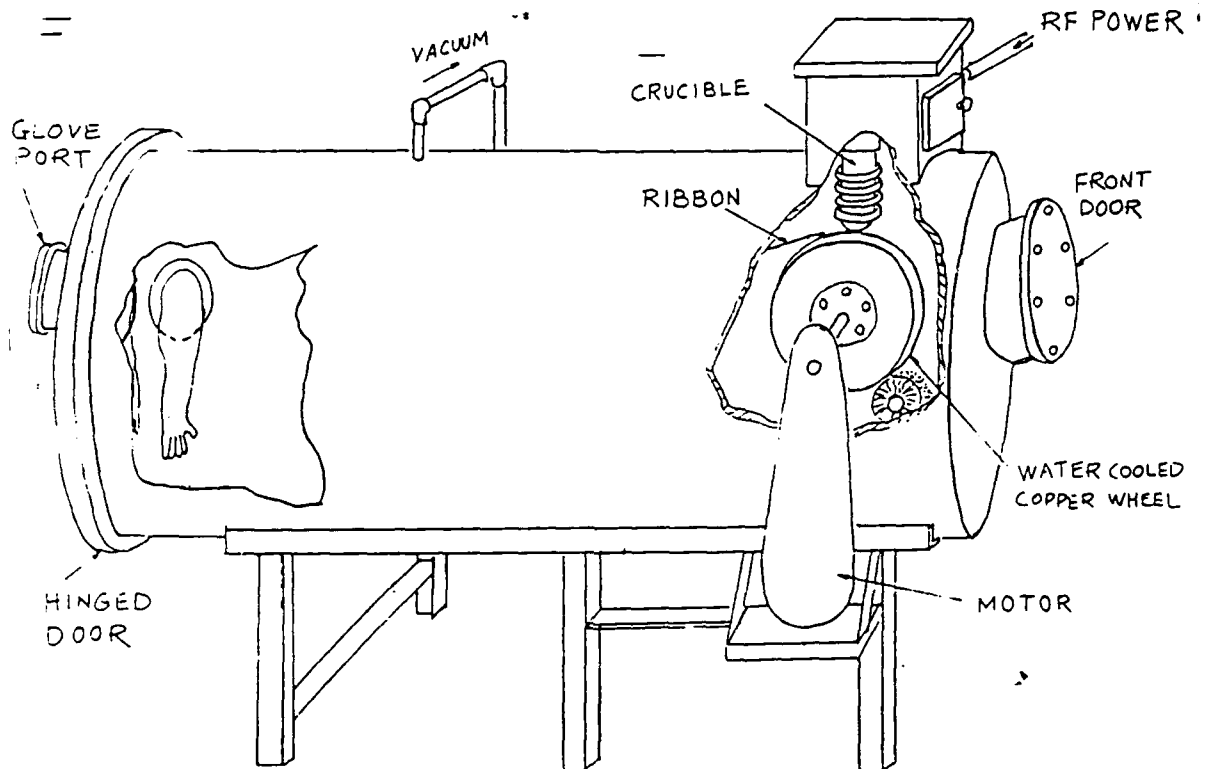

1. Schematic perspective drawing of the pilot scale melt spinner.

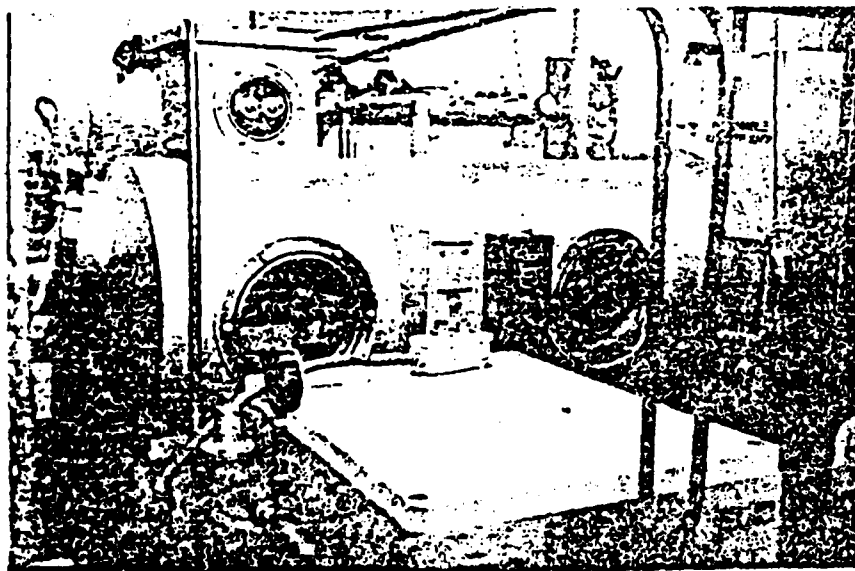

2. Side view of spinner.

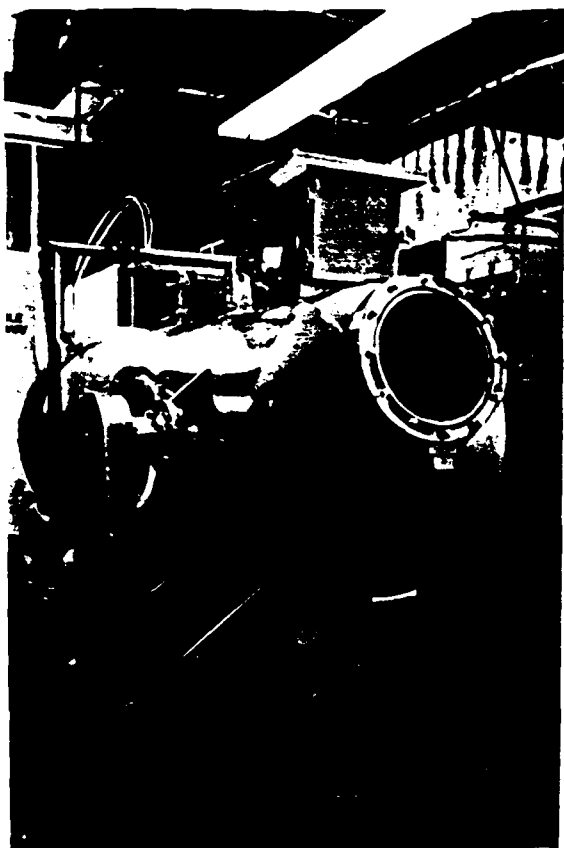

3. Front view of spinner.

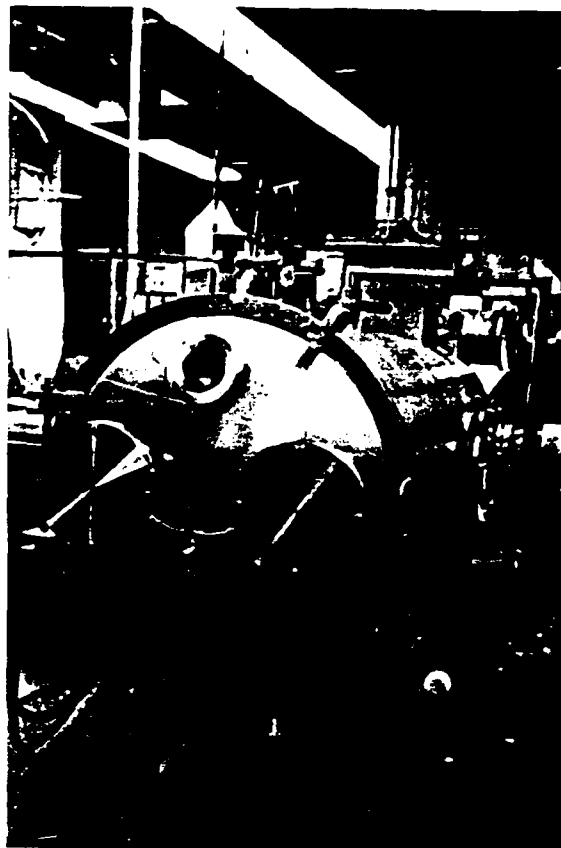

4. Rear view of spinner.

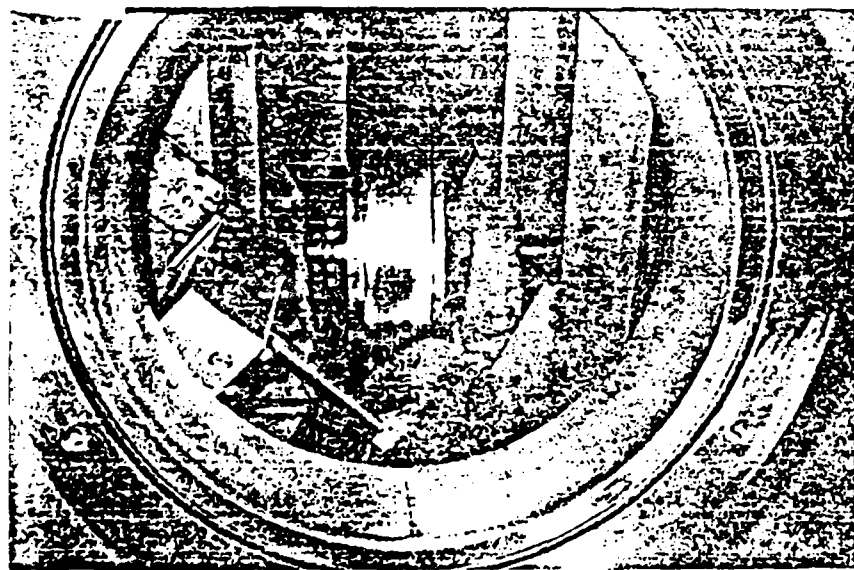

5. View through front port, showing quenching wheel and brush used to clean wheel during spinning.

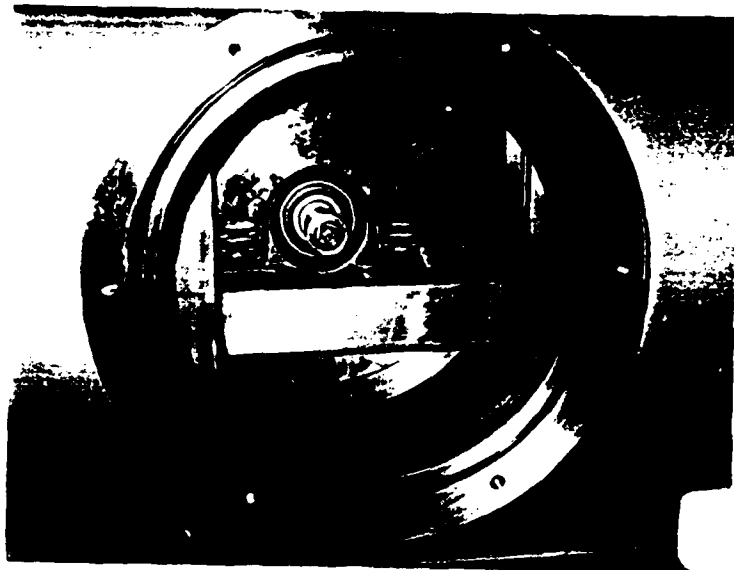
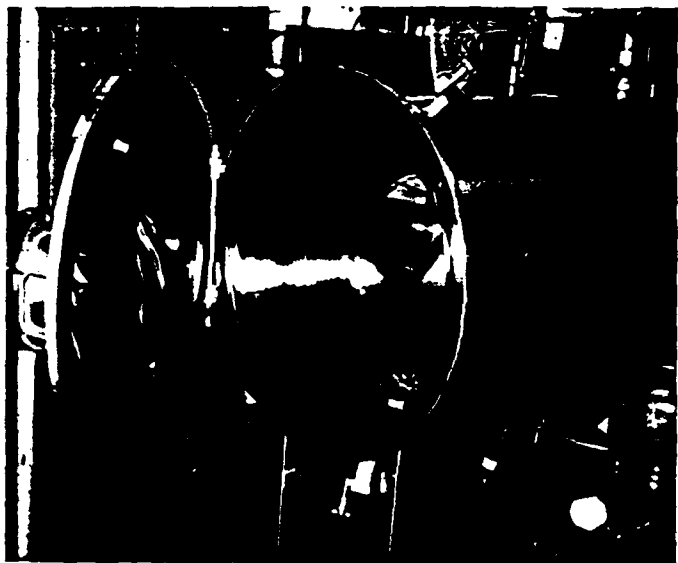

6. Rear of spinner chamber, opened.

7. Side port of spinner, showing wheel and bearing.



8. Crucible chamber (see Fig. 2 for location on top).

9. Pillar induction power supply.

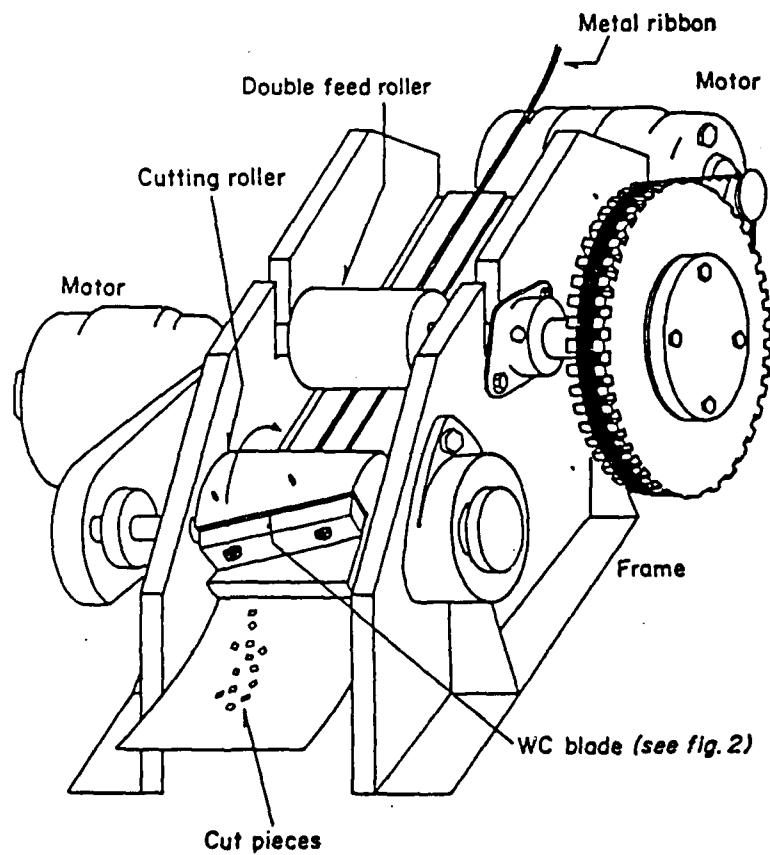

10. Schematic drawing of high-speed chopper for preparation of melt spun ribbon flakes.

APPENDIX I

Volume 2, number 3

MATERIALS LETTERS

February 1984

P/M FLAKE MATERIAL PREPARED BY MECHANICAL CHOPPING
OF RAPIDLY QUENCHED METALLIC RIBBON

S.H. WHANG and B.C. GIESSEN

*Materials Science Division, Barnett Institute of Chemical Analysis & Materials Science,
Northeastern University, Boston, MA 02115, USA*

Received 29 November 1983

Ductile metallic ribbons prepared by melt spinning can be easily cut into flakes suitable for P/M processing by a mechanical chopper designed to tear off ribbon flakes by combining a rotating blade and a bed knife. Details of the design features are described.

1. Introduction

Alloys rapidly quenched as melt spun ribbons have superior cooling rates and uniformity compared to alloys atomized as powder; however, wide application of ribbon processes to make bulk alloys by P/M has been hampered by the fact that thin ribbons are not well suited to direct compaction and subsequent P/M consolidation. To obtain powders from ribbons, pulverization e.g., by hammer milling, can be used for brittle ribbons; alternatively, certain ductile ribbons can be pulverized following reversible hydrogen embrittlement [1]. However, most quenched alloy ribbons of current technical interest are neither brittle nor can they be treated easily by hydrogen embrittlement. As an alternative, we have examined the possibility of chopping the ribbon mechanically into flakes which can be used for P/M processing.

2. Design features

Fig. 1 shows a schematic drawing of a chopper designed to tear off melt spun alloy ribbon at various speeds into pieces of various lengths. The chopper consists essentially of feeding components and chopping components. Ribbons are fed in by one or two coupled rollers that supply the ribbon to the chopper at a constant rate. The chopping components include

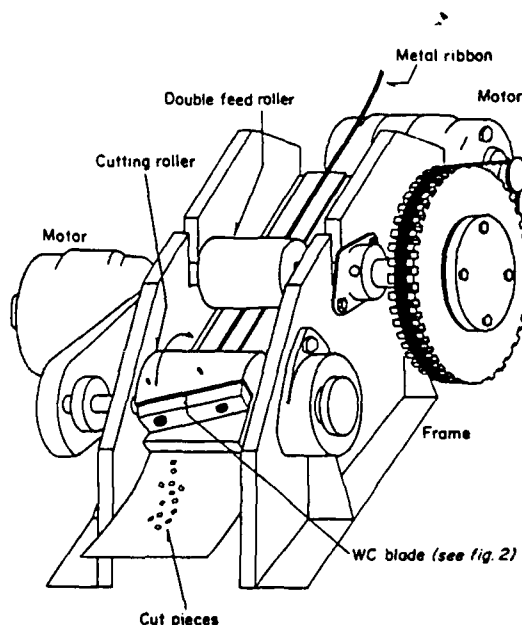

Fig. 1. Schematic drawing of high speed chopper for preparation of melt spun ribbon flakes.

a bed knife and a roller with two tungsten carbide blades. The two components are driven separately by two motors. The length of the chopped ribbon pieces L is determined by the ratio of the feeding speed and the cutting speed,

$$L = DM/IN, \quad (1)$$

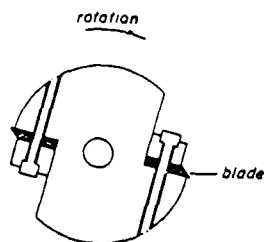

Fig. 2. Detail drawing of cutting roller.

where M is the rotation rate of the feeding roller, N the rotation rate of the cutting roller, D the diameter of the feeding roller and I the number of blades on the cutting roller. In order to reduce L significantly, I or N must be increased, assuming a constant feeding speed, which is determined by the melt spinning process taking place prior to chopping.

Details of the chopping component are shown in figs. 1 and 2. The rotating blades, tilted at an angle of 15° against the bed knife, initiate a crack at the edge of the ribbon and then tear it off in a shearing motion. This characteristic of the process is essential; once the crack is generated, its propagation across the ribbon width requires only a small amount of tearing force. By contrast, a cut in which the rotating blade is parallel to the bed knife and moves normal to it would require considerable force. For example, in amorphous metals, the crack extension force F_c at which catastrophic tearing occurs [2,3] is

$$F_c = (\sigma_y \epsilon_f) t, \quad (2)$$

where σ_y is yield stress, ϵ_f is strain to failure and t is the ribbon thickness. If the sheet is ≈ 2 mm wide, ≈ 25 μ m thick, ϵ_f is $\approx 1.5 \times 10^{-5}$ and σ_y is taken to be ≈ 6 GPa, $F_c \approx 2.25$ Pa according to eq. (2). By contrast, if similar assumptions are made for a normal cut

with parallel knife edges, F_c increases to ≈ 180 Pa. Thus, in this case, the ribbon may readily bend into the gap between the blade and the bed knife instead of being cut.

3. Results

Using a cutter with $I = 2$ and $D \approx 150$ mm and operating conditions of $M = 14$ and $N = 1050$, 1 mm wide ribbons of highly ductile CuZr metallic glass were readily cut into 1 mm long flakes of approximately square shape suitable for compaction e.g., by hot extrusion. In order to improve the capability of the equipment, especially the cutting rate, use of highly wear-resistant materials for the blade and the bed knife is essential.

Acknowledgement

This unit is part of the DARPA sponsored melt spinning facility at Northeastern University; one of us (SHW) thanks for support by the Office of the Naval Research, and the other (BCG) acknowledges support by the Army Research Office Durham. Contribution #182 of the Barnett Institute.

References

- [1] B.C. Giessen, S.H. Whang and F. Dabkowski, in: Rapid solidification processing, Vol. 3, ed. R. Mehrabian (NBS, Washington, 1983) p. 435.
- [2] R.S. Rivlin and A.G. Thomas, J. Polymer Sci. 10 (1952) 291.
- [3] H. Kimura and T. Masumoto, Scripta Met. 9 (1975) 211.

THE RAPID SOLIDIFICATION PROCESSING (RSP) ALLOY PREPARATION FACILITY
AT NORTHEASTERN UNIVERSITY
(SPONSORED BY DARPA)

Melt spinning is widely considered to be the method of choice for the rapid solidification processing of alloys under the twin requirement of very high cooling rates (10^5 - 10^6 K sec⁻¹) and optimal uniformity of the quenching histories of different specimen regions. In addition, melt spinning is a high-productivity, low-cost method capable of a large alloy throughput.

Based on these considerations, a facility for the preparation of RSP alloys in research quantities of 0.1 to 1 kg per run using a melt spinning technique has been established in the Materials Science Division of the Institute of Chemical Analysis at Northeastern University under partial DARPA sponsorship. For those alloys permitting melting in silica or ceramic crucibles, two melt spinning units are available; each unit is contained in a vacuum chamber system for operation under controlled atmosphere, making these units suitable for oxygen sensitive alloys melting at elevated temperatures such as superalloys and other refractory reactive alloys. Rapid recycling in the case of identical alloys assures adequate productivity and makes preparation of alloys in quantities up to 50 kg possible. After spinning, alloys can be optionally characterized by x-ray diffraction, differential scanning calorimetry (DSC), etc.

Samples are presently delivered in three forms: for small quantities (up to 100 g), as well defined lengths of ribbons 1-5 mm wide; for larger quantities, in the form of bales of loose or compacted, melt spun ribbons about 1 mm wide; for brittle alloys, as comminuted powders of specified particle size range.

It may be pointed out that an arc furnace melt spinning system suitable for more reactive or refractory alloys is also available.

The facility at NU is operated by experienced staff and is used by researchers from several government agencies, as well as industry and academic institutions. Responsibility for its operation lies with Professor B. Giessen, 341 MU, 617-437-2827, and Dr. S. Whang, 341 MU, 617-437-2849.

OPERATION OF SUBCONTRACT TO SUPPLY RSP ALLOYS TO *XX Co.*

Using the DARPA sponsored RSP melt spinning facility described in the appended material, we propose to prepare RSP alloys as required by *XX Co.*

in the research program on the effects of rapid solidification on *YY* properties proposed to the *ZZ Agency.*

Alloys will be supplied by *XX* and will be melt spun and pulverized at Northeastern University. Ribbon material for metallurgical studies as well as sieved and graded powders will be delivered to *XX Company.* Special care will be taken to avoid interstitial impurity pick-up or trace cross contamination from other specimens prepared in this program.

Prior to initiating melt spinning runs in the required scale, appropriate experiments will be made to determine suitable crucible materials (silica or, if required, ceramics such as alumina or zirconia) and optimal spinning parameters.

The schedule of alloys to be prepared and delivered follows:

- Year I: 12 alloys - 2 kg each
- Year II: 2 alloys - 10 kg each
- Year III: 1 alloy - 50 kg

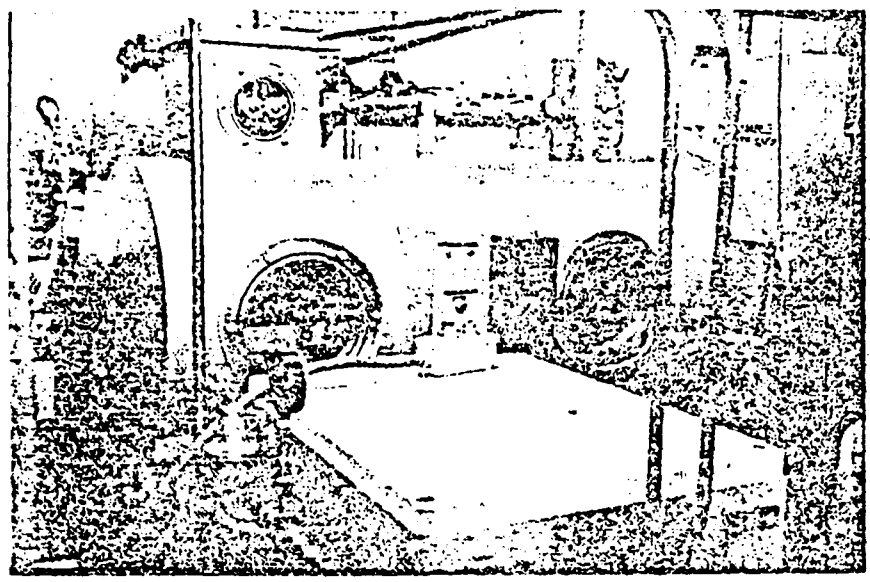

Side view of melt spinning unit. Note rectangular crucible chamber on top of main vacuum tank; part of power supply is visible in foreground. Bearing of spinning wheel can be seen through left side window.

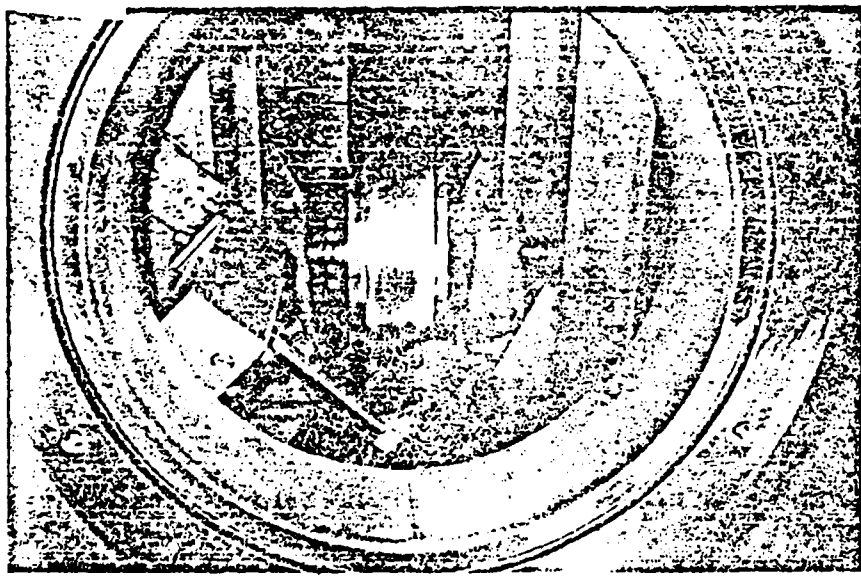

View through front port, showing quenching wheel and brush used to clean wheel during spinning.