

DTIC FILE COPY

(4)

WSRL-TR-44/88

AR-005-434

AD-A210 525



THE CONTAINMENT CHARACTERISTICS OF A  
PORTABLE REINFORCED CONCRETE WALL  
UNIT IN A SMALL EXPLOSIVES INCIDENT

M.J. BONE and B. HENDERSON

ORDNANCE SYSTEMS DIVISION  
WEAPONS SYSTEMS RESEARCH LABORATORY

DTIC  
ELECTE  
JUL 25 1989  
S E D

Approved for Public Release

COPY No.

SEPTEMBER 1988



DEPARTMENT OF DEFENCE  
DEFENCE SCIENCE AND TECHNOLOGY ORGANISATION

89 7 25 045

UNCLASSIFIED



TECHNICAL REPORT  
WSRL-TR-44/88

**THE CONTAINMENT CHARACTERISTICS OF A PORTABLE  
REINFORCED CONCRETE WALL UNIT IN A SMALL  
EXPLOSIVES INCIDENT**

M.J. Bone and B. Henderson

**ABSTRACT (U)**

An experiment was conducted in September 1987 at Woomera, to test the effectiveness of a reinforced concrete wall module. Wall modules, one designed to TM-5-1300 (an American design code) and another variant, were positioned close to a propellant incorporator loaded with 10 kg NEQ of explosives. The mixer contents were detonated.

Subsequent examination of the site enabled conclusions to be drawn on the adequacy of the design and the effectiveness of the wall modules as lethal fragment reflectors.

© Commonwealth of Australia

Author's address:  
Ordnance Systems Division  
Weapons Systems Research Laboratory  
PO Box 1700, Salisbury  
South Australia

Requests to: Chief, Ordnance Systems Division

UNCLASSIFIED

## TABLE OF CONTENTS

	Page
1. INTRODUCTION	1
2. EXPERIMENT DETAIL	1
2.1 Process equipment	1
2.2 Explosives	1
2.3 Layout	2
2.4 Wall module design	2
2.5 Measurements	2
2.6 Film records	2
3. RESULTS/OBSERVATIONS	3
3.1 Fragment search	3
3.2 Damage assessment	3
3.3 Velocity measurement	3
3.4 Film records	4
4. DISCUSSION	4
4.1 Fragment containment	4
4.2 Adequacy of design	4
4.3 Anchorage of wall units	4
4.4 Blast deflection	5
4.5 Velocity measurements	5
5. CONCLUSIONS	5
6. RECOMMENDATION	5
7. ACKNOWLEDGEMENTS	5
REFERENCES	6
LIST OF PLATES	
Plate 1. Starr mixer	61
Plate 2. Starr mixer	62
Plate 3. Starr mixer	62
Plate 4. Pre-explosion site arrangement	63

	Page
Plate 5. Mesh reinforcing	64
Plate 6. Starr mixer bowl showing electrical foil	65
Plate 7. Post-explosion site view	66
Plate 8. Post-explosion site view	67
Plate 9. Front faces of wall modules	68
Plate 10. Rear view faces of wall modules	69
Plate 11. Dislodged anchor bolt	70
Plate 12. Fibrecrete front face pitting	71
Plate 13. Approach to separation	72

## LIST OF APPENDICES

I SITE LAYOUT DWGS PD 9301001 AND 9301020	7
Figure I.1 Base PD 9301020	7
Figure I.2 Proof test installation PD 9301001	8
II WALL MODULE MK 1 DWG PD 9275020	9
Figure II.1 Wall module, reinforce PD 9275020	9
III BLAST GAUGE DETAILS	11
Figure III.1 Gauge frame holder	11
Figure III.2 Foil securing lug	12
Figure III.3 Fragment detection frame	13
Figure III.4 Fragment detection frame - hole locations	14
Figure III.5 Gas and fragment velocity counter	15
Figure III.6 Gas and fragment velocity counter test box	16
IV FRAGMENT SEARCH RESULTS	17
V FILM SERIES FROM HIGH SPEED CAMERAS	23
Figure V.1 Consecutive shots from VL361	23
Figure V.2 Consecutive shots from VL362	31
Figure V.3 Consecutive shots from VL363	39
Figure V.4 Consecutive shots from VL364	47

VI WALL MODULE MK 2 DWG PD 5205020

59

Figure VI.1 Wall module - Mk 2

59

Accession For	
NTIS GRA&I	<input checked="" type="checkbox"/>
DTIC TAB	<input checked="" type="checkbox"/>
Unannounced	<input type="checkbox"/>
Justification:	
By _____	
Distribution/	
Availability Codes	
Dist	Avail and/or Special
A-1	



## 1. INTRODUCTION

A large number of pilot scale propellant processing activities undertaken by Ordnance Systems Division involve maximum NEQ of 10 kg of explosives material. Such materials which are classified as Hazard Division (HD) 1.1 present a risk of burning to detonation. Should this occur the generation of a large quantity of lethal fragments could be expected.

As a move to standardization with NATO countries, the UN System for Classification of Explosives and the NATO Principles for the Storage of Ammunition and Explosives have been adopted by Australian authorities. For the Department of Defence, the adoption of the UN System and NATO Principles is formalized in DIG (SUP) 20-1(ref.1).

In the implementation of DIG (SUP) 20-1(ref.1), a review of the various explosives licensing situations was undertaken. The application of the OSC(E) 82/2(ref.2) separation distance recommendations was seen as appropriate. However, a prerequisite to application of these distances was that the licenced situation have "demonstrated containment". This has been taken as an expression of the philosophy that non-involved personnel should not be subjected to attack by lethal fragments in an explosives incident.

A proposal was developed to meet this prerequisite by the use of close-sited reinforced concrete walls. These walls were to be so positioned that they would collect all fragments issuing in "risk" directions. The proposal was seen as being valid in situations where the explosives load did not exceed 10 kg NEQ HD 1.1.

In the absence of test data on equivalent structures at this explosives load level, the validity of the proposal needed testing. The experiment was set up to simulate a 10 kg explosives processing situation. The test and subsequent results are detailed in this report.

## 2. EXPERIMENT DETAIL

### 2.1 Process equipment

Because it was desired to test the "worst case" with respect to generation of primary fragments, a propellant mixing scenario was developed. An obsolete horizontal mixer, of Starr origin, was made available for the test. This mixer, with water jacketting and sigma blades (refer Plates 1,2,3) was fabricated in stainless steel. The mixer was left in its supporting framework of covered mild steel angle iron. The drive train was removed at the shaft coupling and the hydraulic tilt cylinder also removed. This left a total mass of this assembly of 508 kg.

The drive system framework was then used as a support for suspension of an electric motor, vertically above the mixer bowl (refer Plate 4). This superstructure above the centre of the explosives load was intended to approximate the vertical mixing scenario. Total assembled mass was 530 kg.

### 2.2 Explosives

The test was aimed at assessment of the 10 kg NEQ HD 1.1 effect. To achieve this loading the mixer bowl was filled with 8 kg of Plastic Explosive No 4. Detonation was by means of a Tetryl Primer initiated by means of Redcord and an Exploding Bridgewire Detonator.

### 2.3 Layout

A concrete foundation (refer Appendix I - Dwg PBD 9301001,20) was laid to represent a typical process bay floor. The mixer unit frame was bolted to the floor and the concrete modules also fixed to the reinforced concrete, with 25 mm anchor bolts.

The positioning of the wall modules relative to the mixer was based on the proposed siting in the process environment.

#### - + Wall module design

The American design code TM-5-1300 was applied as the basis of design of the module. The height of the wall module was chosen to provide coverage of a 50° trajectory angle from the point of explosion. The shape of the wall module was chosen on the basis of allowing greater access area around process plant than Pendine blocks.

The combination of the desired shape and the prescribed reinforcing density presented the suppliers with some difficulties in fabrication (refer Plate 5). It was therefore decided to test an easy fabrication option offered by utilizing a dispersed steel staple in lieu of the traditional reinforcing. A wall module for the trial was obtained which incorporated dispersed 'Fibre steel' at 90 kg/m<sup>3</sup> in lieu of the bar reinforcing. Technical data on 'Fibre steel' is provided in reference 4. Details of the wall modules are provided in Appendix II - Dwg PBD 9275020.

### 2.5 Measurements

The primary function of the experiment was to establish the effectiveness of containment of primary fragments offered by the wall units. Two opposed 10° sectors were therefore delineated for visual search and recording of fragment distribution.

A secondary aim of the experiment was to measure fragment and blast front velocities. Electrical circuits were established to provide timer interrupts separately for blast at distances of one and two charge diameters from the mixer bowl (370 mm and 740 mm).

The four velocity gauges were fabricated from bee-hive honeycomb frames. Two gauges consisted of two strips of burglar alarm foil connected in series. The remaining gauges consisted of a continuous length of 26 gauge enamelled copper wire. The clock start impulse was obtained from the rupturing of a piece of burglar alarm foil wrapped around the circumference of the mixer bowl (refer Plate 6). Details are provided in Appendix III.

### 2.6 Film records

Four cameras were used to record the event. Positions are shown in the site layout.

VL-361 - A Hycam operating at 5000 frames/s recorded the events in the immediate vicinity of the mixer bowl and wall units.

VL-362 - A Hycam operating at 10000 frames/s and deliberately under-exposed was used to attempt to record the fragments and gas front impacting on the velocity gauges.

VL-363 - A Stalex 16 mm unit operating at 3000 frames/s provided a second general view of the site.

VL-364 - A 70 mm F95 unit operating at 8 frames/s provided a series of still, documentary views.

All cameras were integrated with the firing circuit.

### 3. RESULTS/OBSERVATIONS

#### 3.1 Fragment search

A meticulous search of the  $10^\circ$  sectors was conducted. A less stringent coverage of the remaining arcs out to a radius of 400 m is believed to have located a very high proportion of significant fragments. A total collected mass of 422.5 kg was recorded. Of this mass, remnants of the frame represented 312 kg.

A complete listing of collected fragments is provided in Appendix IV.

In summary, the main direction of fragment distribution was to the south, ie at  $90^\circ$  to the centre line of the search sectors.

Five metal fragments were located in the traversed search arc. All were located within 25 m of the survey datum and averaged only 8 g in mass.

Forty-nine fragments were found in the untraversed search arc with an average mass of 114 g. One 3.5 kg fragment of the mixer bowl was located at a distance of 228 m from the datum point in the search arc.

One hundred and nine other fragments were located (excluding the frame remnants) with an average mass of 971 g.

The drive shaft, clearly visible in Photo 5, 6 and 7 of the VL-364 series, was recovered 110 m from the survey datum on a bearing of  $177^\circ$ . Its mass was 11 kg.

#### 3.2 Damage assessment

Plates 7 to 13 inclusive depict the degree of damage to the site.

There was substantial pitting of the faces of both wall units indicating very vigorous fragment impact. This pitting was most severe at the centre-line junction of the two wall units.

The concrete floor slab was severely cracked and had been penetrated immediately below the mixer bowl.

The wall unit holding down bolts had been ripped out of their holes and the blocks had been slid away from the explosion.

Both of the wall units sustained some cracking. The mesh reinforced block showed a condition close to scabbing on a small portion of its rear face. No material actually separated from the back face.

#### 3.3 Velocity measurement

The ground shock disengaged the clip-in battery holder from the counter attached to the gauges mounted at two charge diameters. No data could be obtained from this system.

Two readings were obtained from the counter for the gauges at one charge diameter. These readings yielded calculated velocities of 900 and 740 m/s for the pressure front.

#### 3.4 Film records

Scrutiny of the frames from the high speed cinematography indicates that, in the early stages of development, the fireball consists of high velocity jets of flame and gas.

No fragments were detected preceding these jets within a distance of two metres from the centre of the detonation.

Frames from each of the four camera films are included as series in Appendix V.

Frame 4 from VL-361 indicates the flame jets have passed through both gauge frames located at 370 mm from the bowl. During the period between frames 3 and 4 (VL-361) the flame front has progressed some 200 mm. With a camera speed of 4.4 frames/ms, the velocity of the flame front is calculated at 880 m/s.

### 4. DISCUSSION

#### 4.1 Fragment containment

The absence of any lethal fragments in the traversed search sector despite the frontal face attack on the wall modules is taken as a measure of their effectiveness. The wall units provided coverage of trajectories up to  $50^\circ$ . The bulk of the high energy projectiles appear to have been launched at trajectories  $\pm 20^\circ$  from horizontal.

The witness marks on the wall unit faces indicate the fragment distribution was quite directional. The main line of emission of fragments in the arc covered by the wall units was along the centre line of the arc. This represented a line perpendicular to the mixer blade axis.

As expected the frame was propelled away from the point of explosion approximately along the line of its centre of gravity.

#### 4.2 Adequacy of design

The damage sustained by the wall unit constructed with the prescribed mesh reinforcing indicated that it was adequate for the purpose. No spalling occurred although separation of one approx 1 kg segment of concrete from the back face was almost forced.

The wall unit using the dispersed reinforcing staples withstood a slightly greater fragment attack, judged by witness marks on the front face. The examination of the rear face did not reveal any approach to a spalling situation.

On the basis of the minimal sustained damage, and the effectiveness as fragment collectors, the wall unit design was modified only slightly for the production order (refer Appendix VI).

#### 4.3 Anchorage of wall units

The dislodging of the anchor bolts is likely to have been due to the flexure of the concrete mounting slab. The subsequent ability of the wall

modules to slide back under attack from fragments and blast offers a shock absorbing or energy dissipating process. In most process situations the 'slide' of the wall units in a limited fashion would be quite acceptable in an explosives incident. It is not considered appropriate therefore to attempt to tie the wall units more securely into the floor structure.

The concern created by this approach to anchorage is that the wall units could be toppled over backwards. This result would contribute significant secondary damage in most pilot plant situations. Consideration must be given to keeping the centre of gravity of the wall unit as far "forward" over the base as possible.

#### 4.4 Blast deflection

An examination of the high speed cinematography indicates that the propagation of both the shock front and fireball were substantially obstructed by the wall units. The fireball is clearly reshaped leaving a protected zone in the shadow of the wall units.

#### 4.5 Velocity measurements

The readings obtained do not correspond with the theoretical calculation of shock wave propagation provided in reference 3. The discrepancy might be explained by the directional nature of the blast evident in the photographic record. In the initial stages the propagation of the blast was predominantly in the vertical direction.

The theoretical calculations suggest that the shock front should overtake the fragments within two charge diameters of the point of explosion. The collected data does not support this.

### 5. CONCLUSIONS

(1) Within the limitations of covering a 50° trajectory and NEQ not exceeding 10 kg, containment by the reinforced concrete wall module is considered demonstrated.

(2) The adequacy of the design of the wall module in both mesh and dispersed staple reinforcing has been established.

### 6. RECOMMENDATION

The wall unit approach be adopted as providing containment for pilot scale process situations up to 10 kg NEQ HD 1.1.

### 7. ACKNOWLEDGEMENTS

The authors wish to acknowledge the support and cooperation of the various groups and personnel engaged in the experiment, specifically:

(1) Messrs Bradley, Levers and Minerds for their efforts in the fragment searches,

(2) Members of Range Measurements Branch for their cinematographic effort, and

(3) Members of Woomera Area Services for their efforts in site preparation.

## REFERENCES

No.	Author	Title
1	-	"Adoption of the UN Classification System and NATO Safety Principles for the Storage of Ammunition and Explosives". Defence Instructions (General) Sup 20-1
2	-	"Quantity Distances for the Storage and Handling of Quantities of Explosives up to 50 kg Above Ground". Operational Safety Committee (Explosives) 82/2
3	-	"Structures to Resist the Effects of Accidental Explosions". US Department of the Army Technical Manual TM-5-1300
4	-	"Fibre steel". Technical Manual published by Australian Wire Industries, November 1981



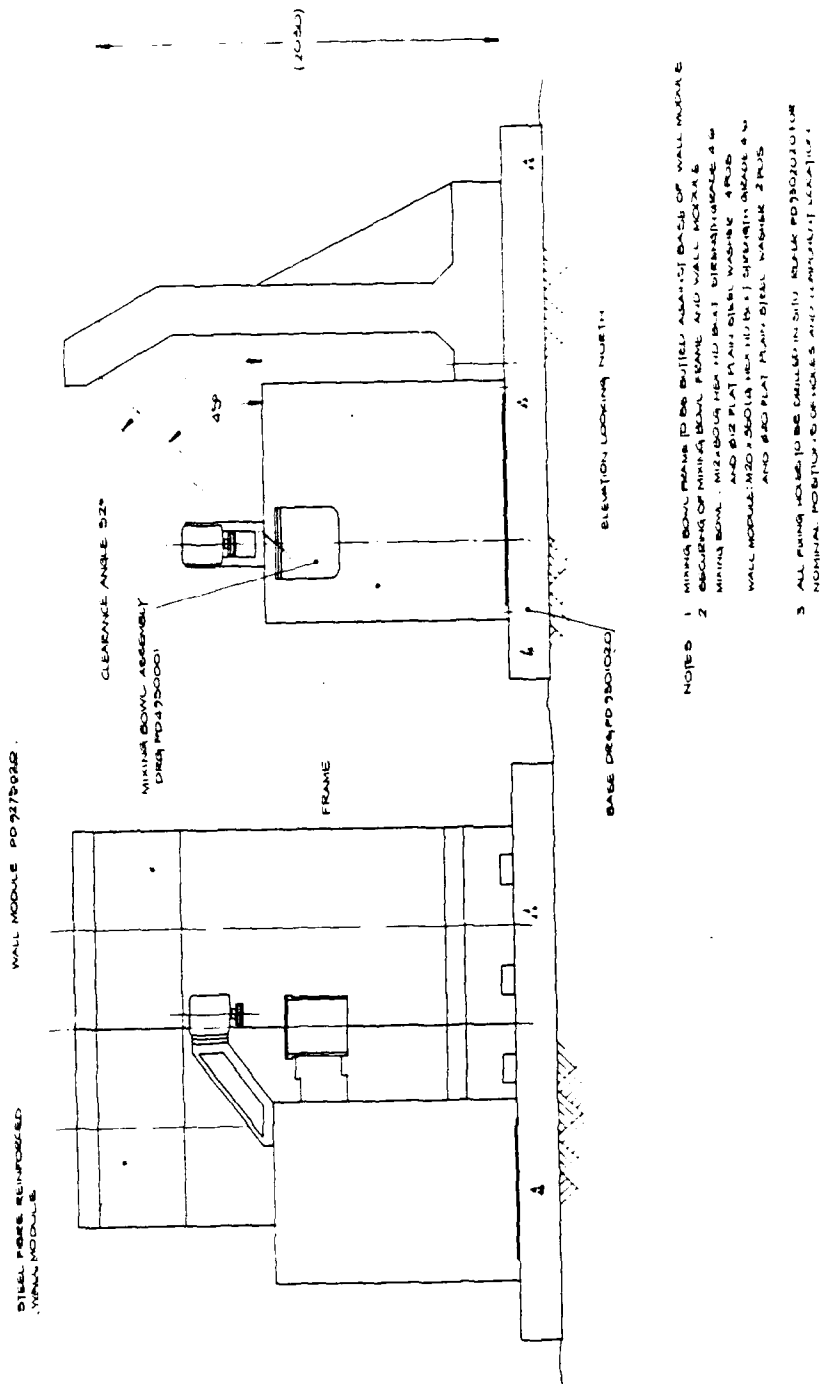

Figure I.2 Proof test installation PD 9301001

NOTES

- 1 CONCRETE
  - 1.1 CONCRETE TO AS 1480
  - 1.2 STRENGTH 21 MPa MIN
  - 1.3 AGGREGATE SIZE 25 MAX
  - 1.4 SLUMP RANGE 100-130
  - 1.5 CONCRETE COVER OVER REINFORCING 30 MIN
- 2 REINFORCING
  - 2.1 DEFORMED REINFORCEMENT BARS TO AS 1502
  - 2.2 WELDED FABRIC AND GIRDER WEAP TO AS 1304
  - 2.3 BEND RADIUS ALL REINFORCING MEMBERS 3x DIA MIN
- 3 ARRISES AND RE-ENTRANT CORNERS TO BE CHAMFERED 25x45° EXCEPT UNDERSIDE OF BASE AND WHERE OTHERWISE INDICATED
- 4 CONCRETE SHALL BE THOROUGHLY COMPACTED BY SUITABLE MEANS DURING PLACEMENT AND SHALL BE THOROUGHLY WORKED AROUND THE REINFORCEMENT AND INTO THE CORNERS OF FORMS
- 5 BOLTING INSERT
  - 5.1 SURFACE FINISH
    - 5.1.1 MACHINED SURFACES ~~NO~~ ALL OVER TUBE AS SUPPLIED
    - 5.1.2 DRESS WELD FLUSH ON TOP SURFACE
  - 5.2 FINISH TREATMENT HOT DIP GALVANISE

ADDITIONAL Y12 Z POSITIONS

ALL LACING AND REINFORCEMENT BARS 40Y12  
TACK WELDED AT INTERSECTION POINTS

HOISTING LOOP 2 POS  
40Y16

F4 GIRDER WEAP DOUBLE LAYER WRAPPED AROUND Y12 WEB REINFORCEMENT AND ATTACHED TO MAIN REINFORCEMENT WHERE POSSIBLE

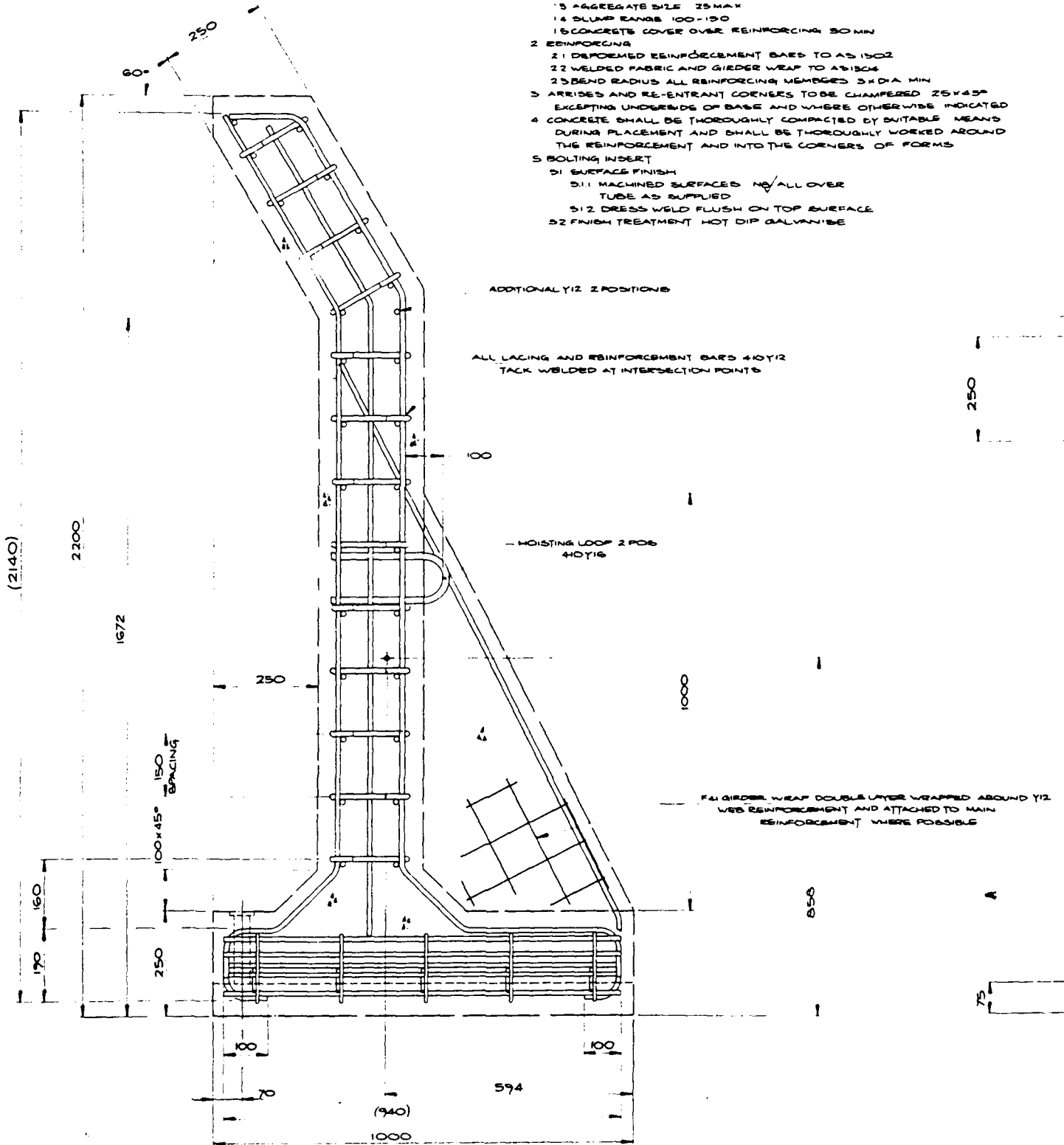

1072

APPENDIX II

WALL MODULE MK 1 DWG PD 9275020

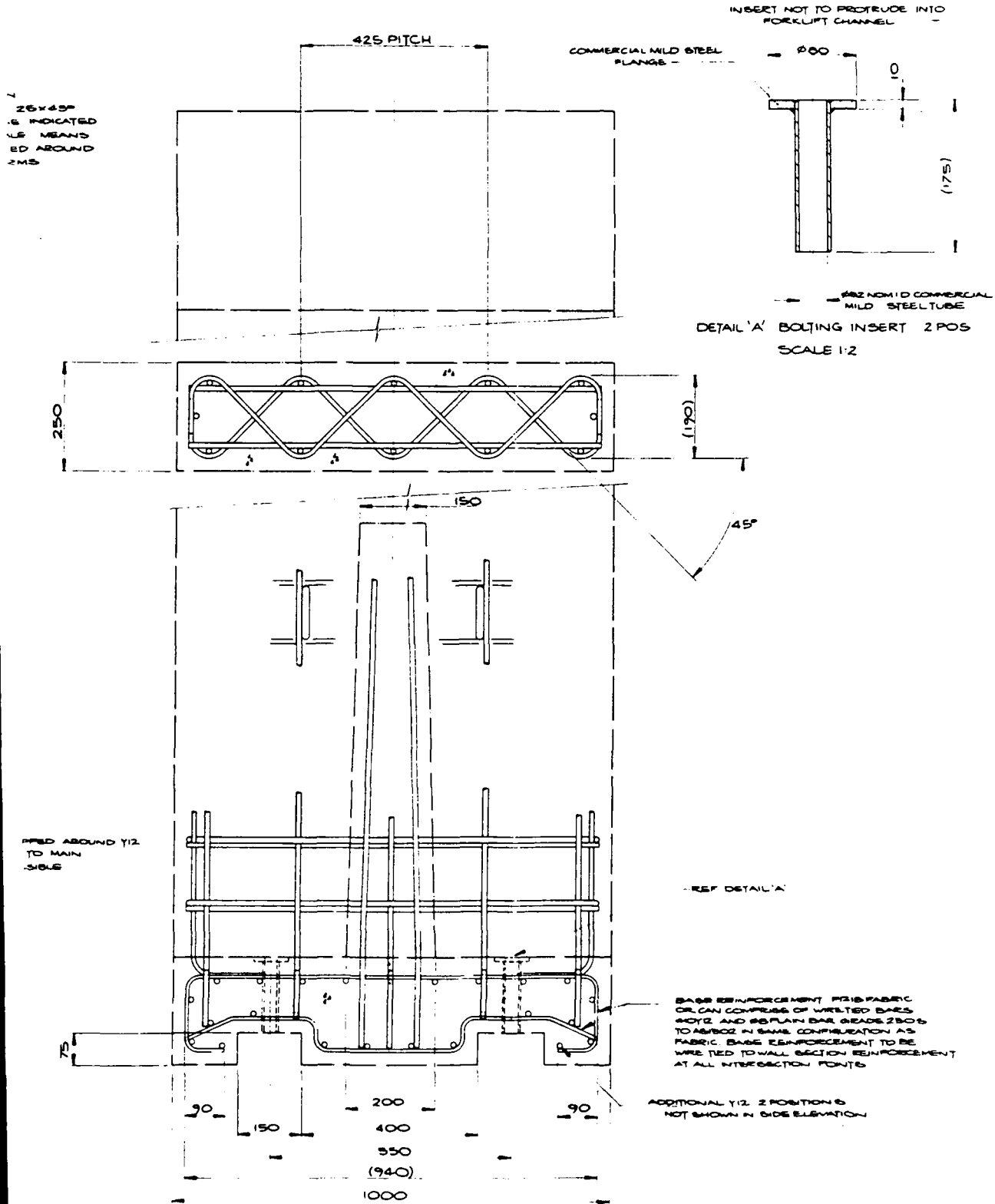

282

Figure II.1 Wall module, reinforce PD 9275020

APPENDIX III  
BLAST GAUGE DETAILS

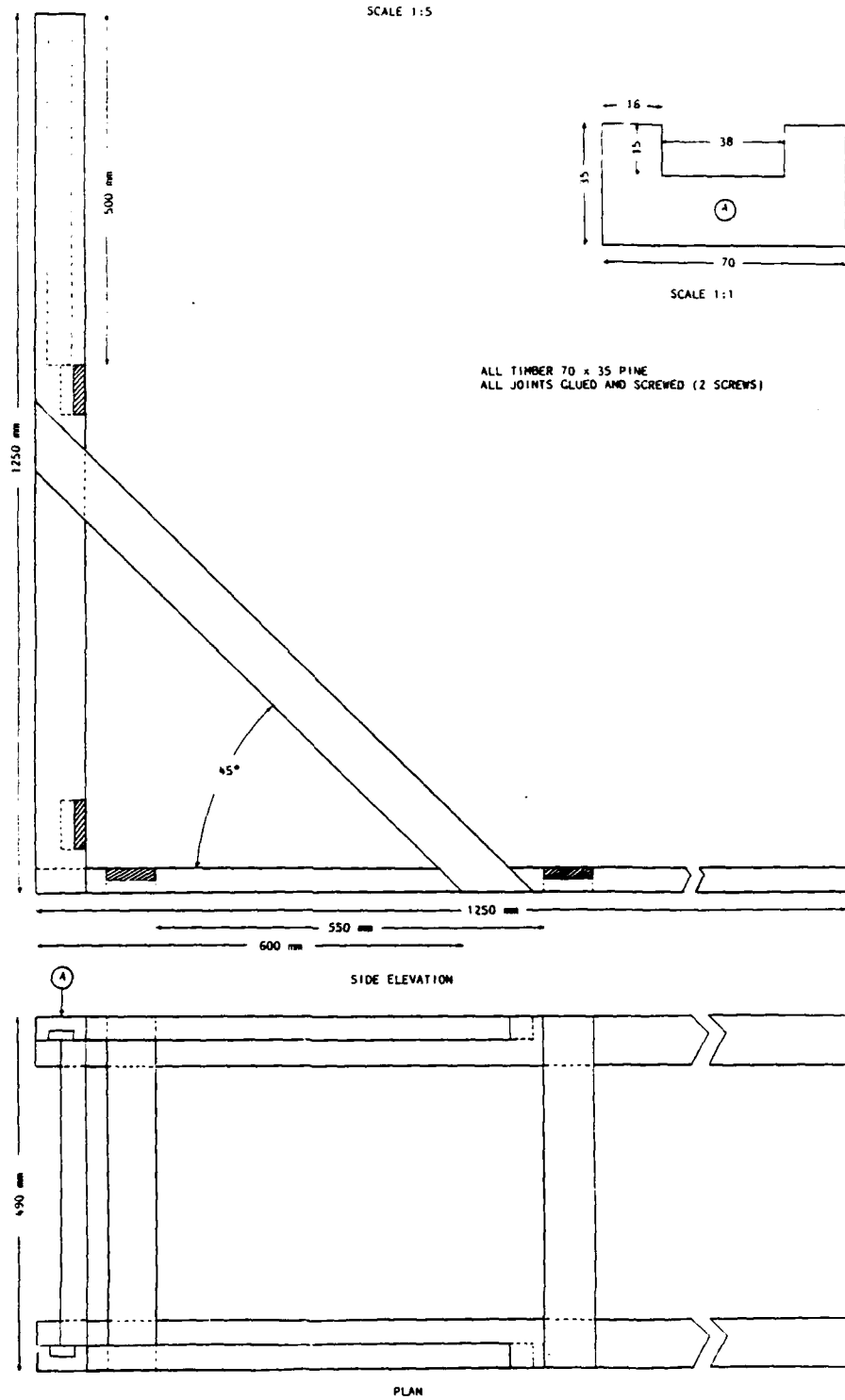
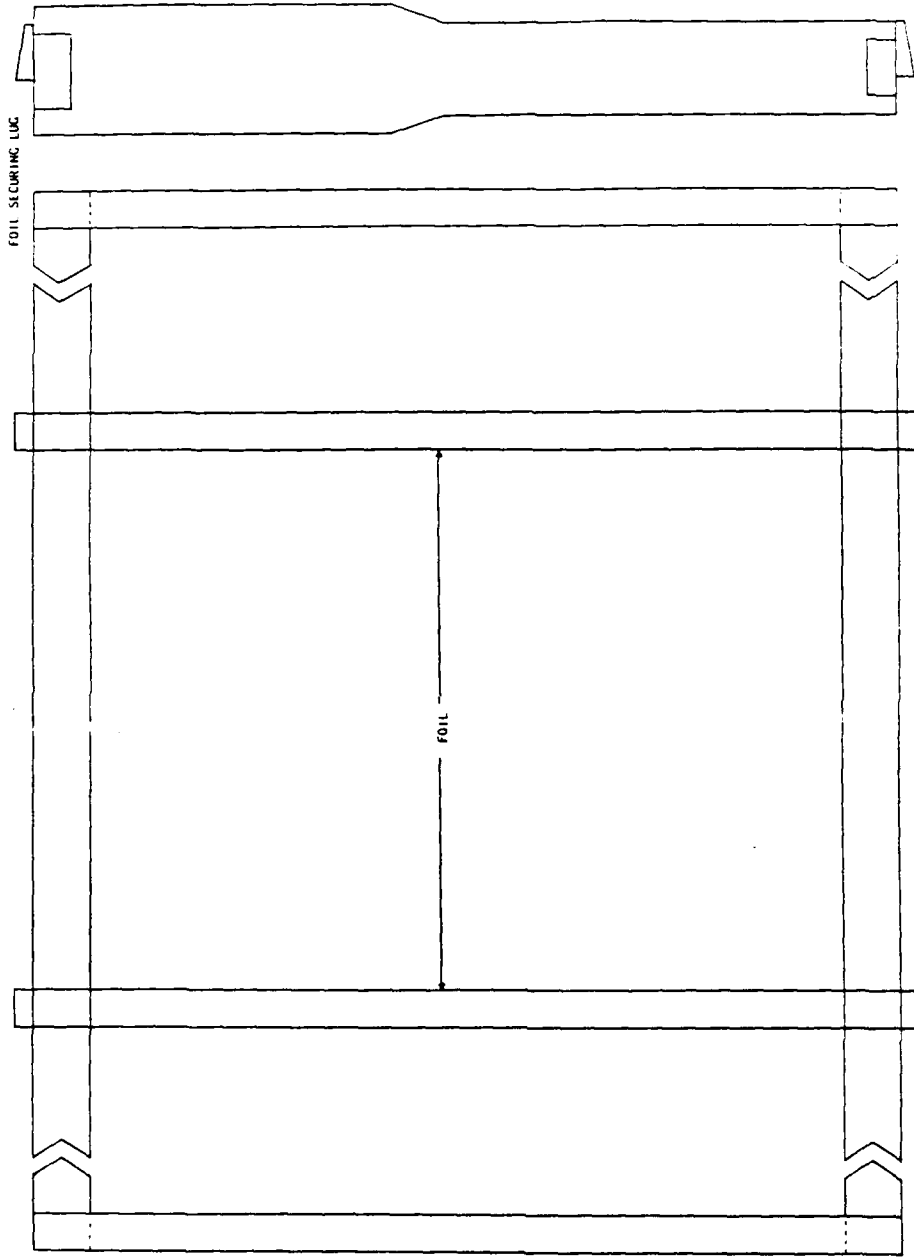

Figure III.1 Gauge frame holder



FOIL SECURING LUG

FOIL

NOTE: FOIL IS CONNECTED IN SERIES

Figure III.2 Foil securing lug

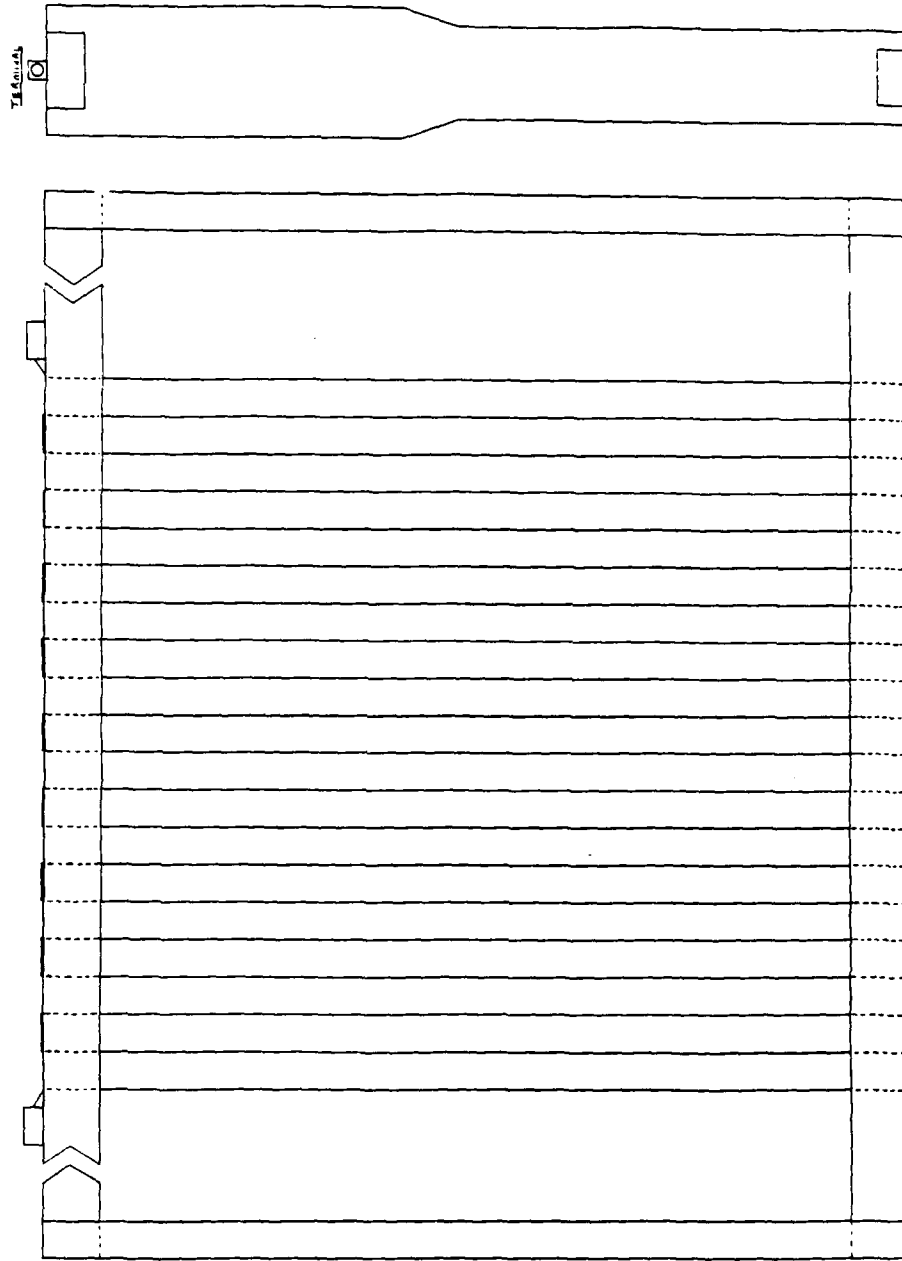

Figure III.3 Fragment detection frame

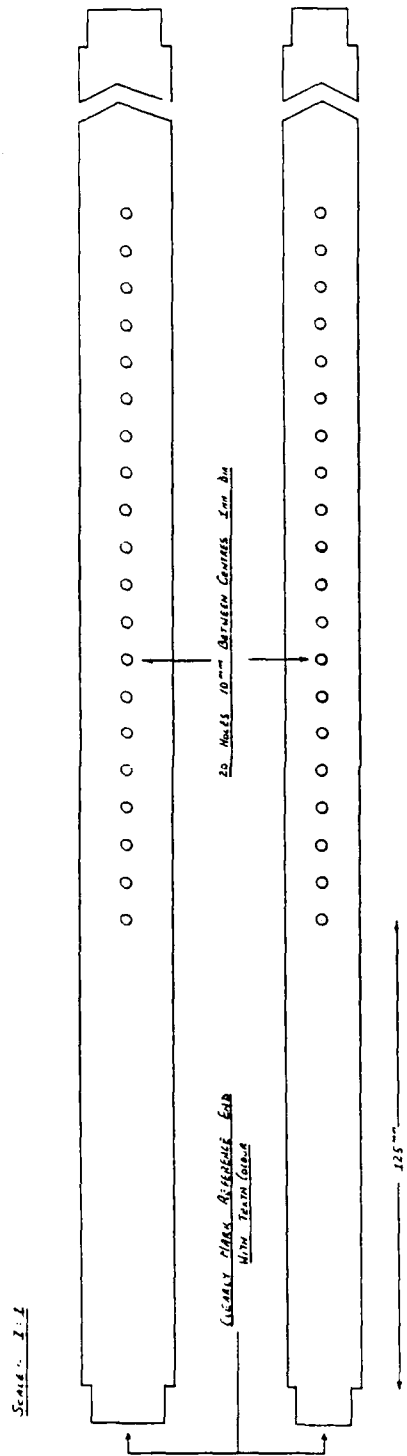

Figure III.4 Fragment detection frame - hole locations

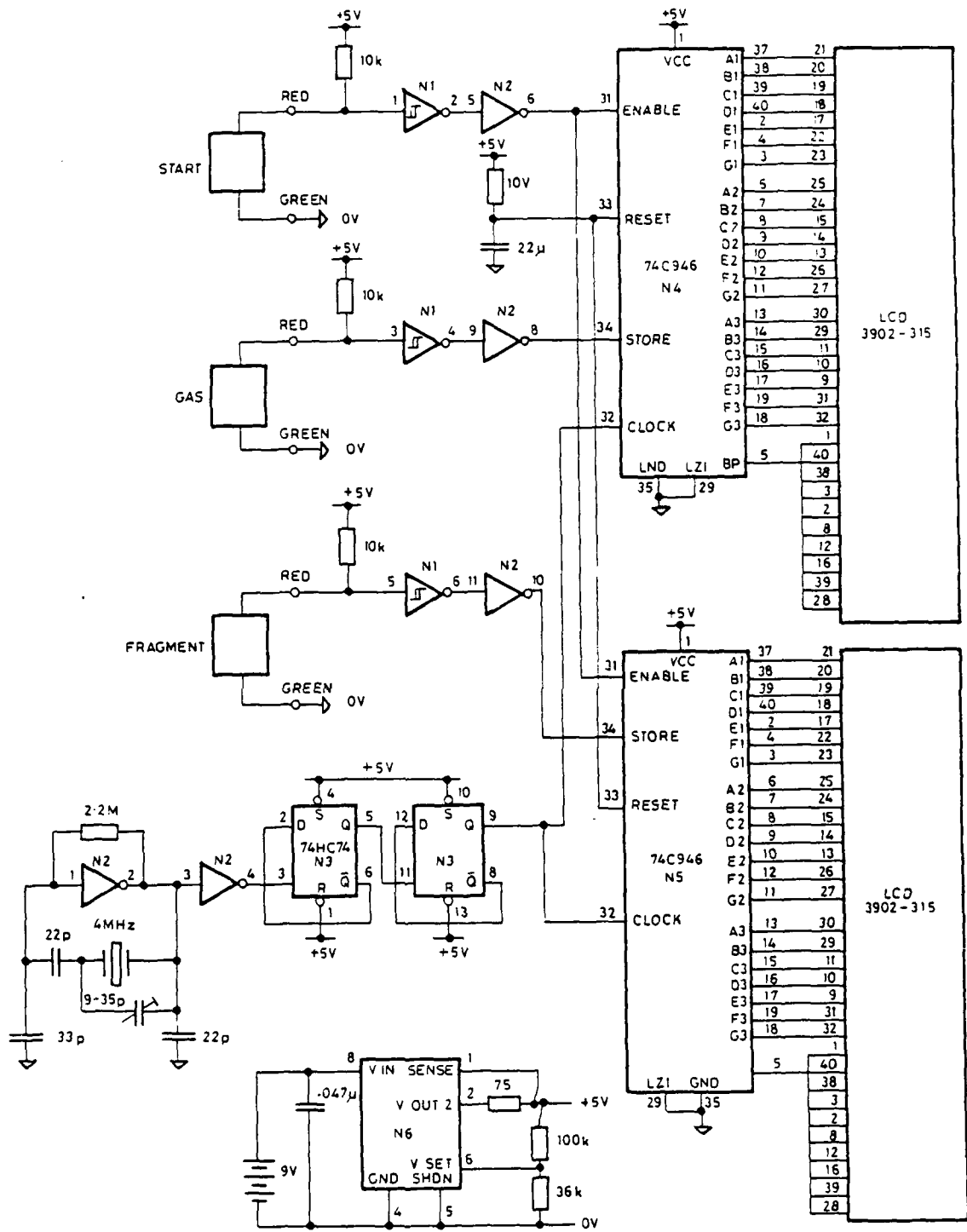

Figure III.5 Gas and fragment velocity counter

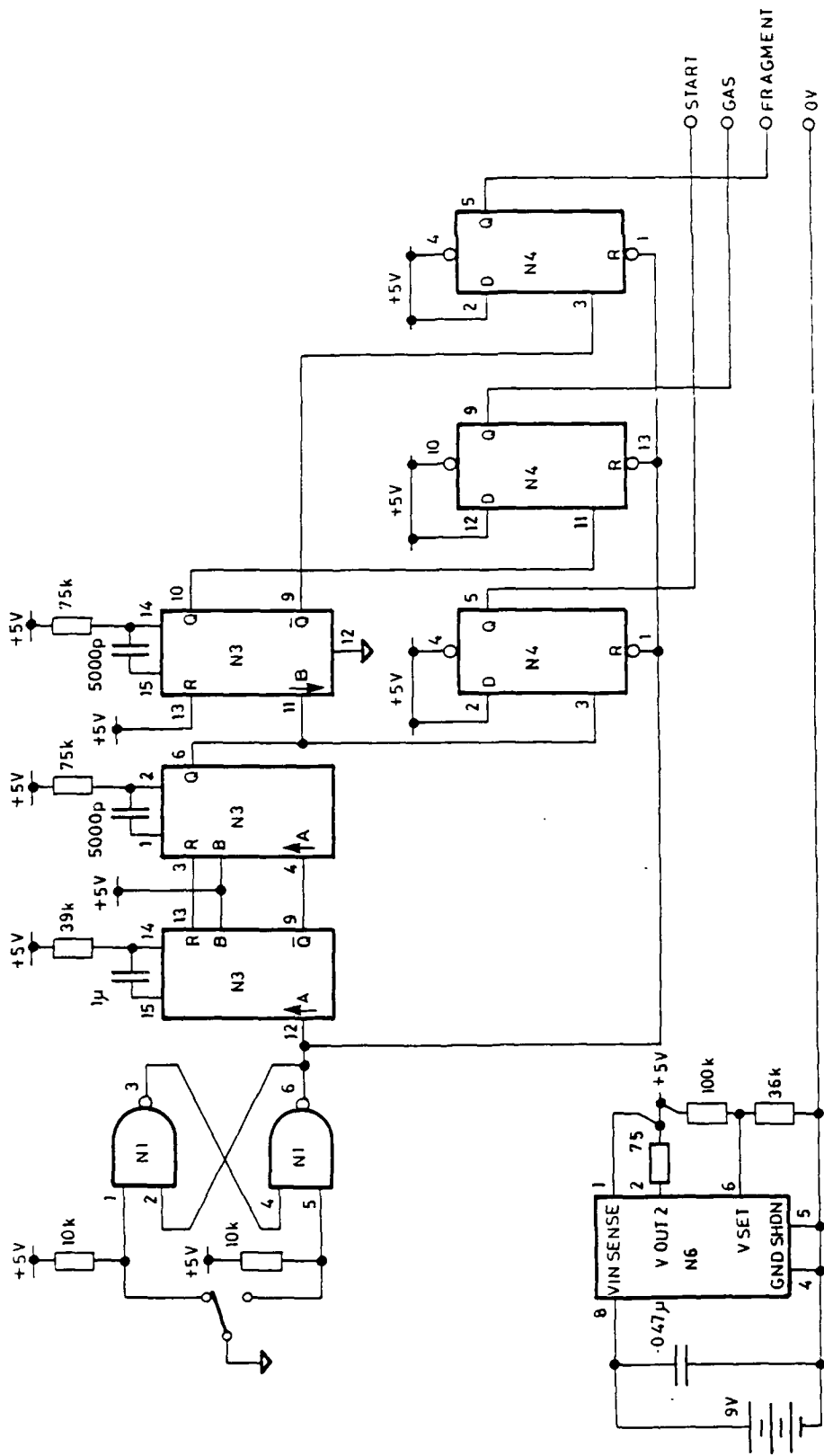

Figure III.6 Gas and fragment velocity counter test box

APPENDIX IV

FRAGMENT SEARCH RESULTS

Portable Wall Traverse Trial - Fragment Analysis

Summary of Fragments Recovered from the Designated Search Areas on the Traversed Side

Record	Degrees	Segment	Mass (kg)	Type Frag	Distance (m)
1	265-275	1	0.002	M	0-25
2	265-275	1	0.010	M	0-25
3	265-275	1	0.007	M	0-25
4	265-275	1	0.010	M	0-25
5	265-275	1	0.012	M	0-25
6	265-275	2	0.000	Nil	25-50
7	265-275	3	0.000	Nil	50-75
8	265-275	4	0.000	Nil	75-100
9	265-275	5	0.000	Nil	100-125
10	265-275	6	0.000	Nil	125-150
11	265-275	7	0.000	Nil	150-175
12	265-275	8	0.000	Nil	175-200
13	265-275	9	0.000	Nil	200-225
14	265-275	10	0.000	Nil	225-250
15	265-275	11	0.000	Nil	250-275
16	265-275	12	0.000	Nil	275-300
17	265-275	13	0.000	Nil	300-325
18	265-275	14	0.000	Nil	325-350
19	265-275	15	0.000	Nil	350-375
20	265-275	16	0.000	Nil	375-400

Summary of Fragments Recovered from the Designated Search Areas on the Untraversed Side

Record	Degrees	Segment	Mass (kg)	Type Frag	Distance (m)
21	85-95	1	0.742	M	0-25
22	85-95	1	0.167	M	0-25
23	85-95	1	0.141	M	0-25
24	85-95	1	0.090	M	0-25
25	85-95	1	0.019	M	0-25
26	85-95	1	0.009	M	0-25
27	85-95	1	0.080	M	0-25
28	85-95	1	0.034	M	0-25
29	85-95	1	0.049	M	0-25
30	85-95	1	0.036	M	0-25
31	85-95	1	0.008	M	0-25
32	85-95	1	0.007	M	0-25
33	85-95	1	0.006	M	0-25
34	85-95	1	0.002	M	0-25
35	85-95	1	0.010	M	0-25
36	85-95	1	0.006	M	0-25
37	85-95	1	0.006	M	0-25
38	85-95	1	0.007	M	0-25
39	85-95	1	0.012	M	0-25
40	85-95	1	0.009	M	0-25
41	85-95	1	0.009	M	0-25
42	85-95	1	0.007	M	0-25
43	85-95	1	0.006	M	0-25

Record	Degrees	Segment	Mass (kg)	Type Frag	Distance (m)
44	85-95	1	0.007	M	0-25
45	85-95	1	0.008	M	0-25
46	85-95	1	0.004	M	0-25
47	85-95	1	0.005	M	0-25
49	85-95	1	0.006	M	0-25
50	85-95	1	0.003	M	0-25
51	85-95	1	0.004	M	0-25
52	85-95	1	0.004	M	0-25
53	85-95	1	0.003	M	0-25
54	85-95	1	0.004	M	0-25
55	85-95	1	0.003	M	0-25
56	85-95	1	0.007	M	0-25
57	85-95	1	0.004	M	0-25
58	85-95	1	0.007	M	0-25
59	85-95	1	0.007	M	0-25
60	85-95	1	0.005	M	0-25
61	85-95	1	0.004	M	0-25
62	85-95	1	0.007	M	0-25
63	85-95	1	0.003	M	0-25
64	85-95	1	0.003	A	0-25
65	85-95	1	0.004	A	0-25
66	85-95	1	0.002	A	0-25
67	85-95	1	0.002	A	0-25
68	85-95	1	0.006	A	0-25
69	85-95	1	0.008	A	0-25
70	85-95	1	0.003	A	0-25
71	85-95	1	0.003	A	0-25
72	85-95	1	0.003	A	0-25
73	85-95	1	0.003	A	0-25
74	85-95	1	0.002	A	0-25
75	85-95	1	0.002	A	0-25
76	85-95	1	0.002	A	0-25
77	85-95	1	0.002	A	0-25
78	85-95	2	0.023	M	25-50
79	85-95	2	0.254	M	25-50
80	85-95	1	0.023	M	25-50
81	85-95	2	0.009	M	25-50
82	85-95	2	0.005	A	25-50
83	85-95	2	0.005	A	25-50
84	85-95	3	0.168	M	50-75
85	85-95	4	0.000	Nil	75-100
86	85-95	5	0.000	Nil	100-125
87	85-95	6	0.000	Nil	125-150
88	85-95	7	0.000	Nil	150-175
89	85-95	8	0.035	M	180
90	85-95	9	0.000	Nil	200-225
91	85-95	10	3.500	M	228-25
92	85-95	11	0.000	Nil	250-275
93	85-95	12	0.000	Nil	275-300
94	85-95	13	0.000	Nil	300-325
95	85-95	14	0.000	Nil	325-350
96	85-95	15	0.000	Nil	350-375
97	85-95	16	0.000	Nil	375-400

## Summary of Fragments Recovered from Undesignated Search Areas

Record	Degrees	Segment	Mass (kg)	Type Frag	Distance (m)
98	0-180		3.200	M	0-25
99	0-180		0.039	M	0-25
100	0-180		0.035	M	0-25
101	0-180		0.005	M	0-25
102	0-180		0.009	M	0-25
103	0-180		0.027	M	0-25
104	0-180		0.010	M	0-25
105	0-180		0.009	M	0-25
106	0-180		0.145	M	0-25
107	0-180		0.089	M	0-25
108	0-180		0.037	M	0-25
109	0-180		0.055	M	0-25
110	0-180		0.113	M	0-25
111	0-180		0.452	M	0-25
112	0-180		0.156	M	0-25
113	0-180		0.081	M	0-25
114	0-180		0.435	M	0-25
115	0-180		0.123	M	0-25
116	0-180		0.065	M	0-25
117	0-180		1.126	M	0-25
118	0-180		0.434	M	0-25
119	0-180		0.024	M	0-25
120	0-180		0.045	M	0-25
121	0-180		0.092	M	0-25
122	0-180		0.020	M	0-25
123	0-180		0.035	M	0-25
124	0-180		0.045	M	0-25
125	0-180		0.033	M	0-25
126	0-180		0.030	M	0-25
127	0-180		0.010	M	0-25
128	0-180		0.016	M	0-25
129	0-180		0.014	M	0-25
130	0-180		0.022	M	0-25
131	0-180		0.022	M	0-25
132	0-180		0.014	M	0-25
133	0-180		0.009	M	0-25
134	0-180		0.024	M	0-25
135	0-180		0.015	M	0-25
136	0-180		0.013	M	0-25
137	0-180		0.010	M	0-25
138	0-180		0.002	M	0-25
139	0-180		0.004	M	0-25
140	0-180		0.004	M	0-25
141	0-180		0.007	M	0-25
142	0-180		0.004	M	0-25
143	0-180		0.005	M	0-25
144	0-180		0.002	M	0-25
145	0-180		0.002	M	0-25
146	0-180		0.002	M	0-25
147	0-180		0.003	M	0-25
148	0-180		0.006	M	0-25
149	0-180		0.008	M	0-25
150	0-180		0.005	M	0-25
151	0-180		0.004	M	0-25
152	0-180		0.005	M	0-25
153	0-180		0.002	M	0-25
154	0-180		0.046	M	0-25

Record	Degrees	Segment	Mass (kg)	Type Frag	Distance (m)
155	0-180		0.194	M	0-25
156	0-180		0.127	M	0-25
157	0-180		0.136	M	0-25
158	0-180		0.107	M	0-25
159	0-180		0.059	M	0-25
160	0-180		0.059	M	0-25
161	0-180		0.063	M	0-25
162	0-180		0.035	M	0-25
163	0-180		0.061	M	0-25
164	0-180		0.027	M	0-25
165	0-180		0.099	M	0-25
166	0-180		0.040	M	0-25
167	160		0.250	M	30
168	189		0.500	M	35
169	165		0.100	M	30
170	176		21.000	M	40
171	135		0.500	M	45
172	170		0.500	M	65
173	177		7.500	M	95
174	185		0.500	M	140
175	180		2.000	M	50
176	177		11.000	M	110
177	178		0.500	M	120
178	179		2.000	M	95
179	179		0.200	M	95
180	176		0.200	M	210
181	180		2.000	M	80
182	180		4.000	M	80
183	175		0.100	M	30
184	165		4.500	M	150
185	195		0.030	M	55
186	195		0.100	M	55
187	190		2.000	M	190
188	180		0.500	M	125
189	173		0.500	M	125
190	155		2.000	M	35
191	180		0.030	M	40
192	180		4.500	M	20
193	159		312.000	M	15
194	150		0.150	M	35
195	1		2.500	M	15
196	5		0.750	M	45
197	320		0.100	M	40
198	180		0.250	M	25
199	45		0.100	M	40
200	175		0.100	M	60
201	175		0.100	M	85
202	180		5.000	M	160
203	180		5.500	M	160
204	135		0.030	M	195
205	20		13.500	M	90
206	25		1.500	M	150

Column heading legend - Type Frag = Type of Fragment  
M = Metal Fragment  
A = Aggregate Fragment

The mass of the mixer and frame prior to detonation was 530 kg.

The mass of recovered metal fragments was 422.459 kg.

The percentage of recovered metal is 79.8%.

Statistics - Traversed Side

Number of metal fragments  
5 records

Average Mass  
5 records averaged  
Mass  
0.008

Statistics - Untraversed Side

Number of metal fragments  
49 records

Average Mass  
49 records averaged  
Mass  
0.114

Statistics - Undesignated Search Areas

Number of metal fragments  
109 records

Average Mass (excluding recovered framework [312 kg])  
108 records averaged  
Mass  
0.971

## Location and Bearing of Fragments Found Outside Designated Search Areas

Record	Descript	Mass (kg)	Distance (m)	Degrees
1	Fragment	0.250	30	160
2	Bearing Outer Race	0.500	35	189
3	Bearing Housing	0.100	30	165
4	Shaft Housing	21.000	40	176
5	Lid	0.500	45	135
6	Bowl	0.500	65	170
7	Angle Iron	7.500	95	177
8	50 mm Flat	0.500	140	185
9	Key Shaft	2.000	50	180
10	Shaft	11.000	110	177
11	Cover Cap	0.500	120	178
12	Arm	2.000	95	179
13	Fragment	0.200	95	179
14	Motor Support	2.000	210	176
15	Base Trunion	2.000	80	180
16	Window Frame	4.000	80	180
17	Oil Seal Ring $\frac{1}{2}$	0.100	30	175
18	Mixer Bowl	4.500	150	165
19	Aluminium Cladding	0.030	55	195
20	Aluminium Cladding	0.100	55	195
21	Motor Support	2.000	190	190
22	Outside Race	0.500	125	180
23	Shaft Housing	0.500	125	173
24	Cover	2.000	35	155
25	Mixer Back Plate	0.030	40	180
26	Angle Iron	4.500	20	180
27	Main Frame Work	312.000	15	159
28	Fragment	0.150	35	150
29	Fragment	2.500	15	1
30	Fragment	0.750	45	5
31	Fragment	0.100	40	320
32	Ring Spacer	0.250	25	180
33	Cover	0.100	40	45
34	Fragment	0.100	60	175
35	Fragment	0.100	85	175
36	Check Plate	5.000	160	180
37	Check Plate	5.500	160	178
38	Trunion Mount	0.030	195	135
39	Motor Armature	13.500	90	20
40	Blade	1.500	150	25

APPENDIX V

FILM SERIES FROM HIGH SPEED CAMERAS

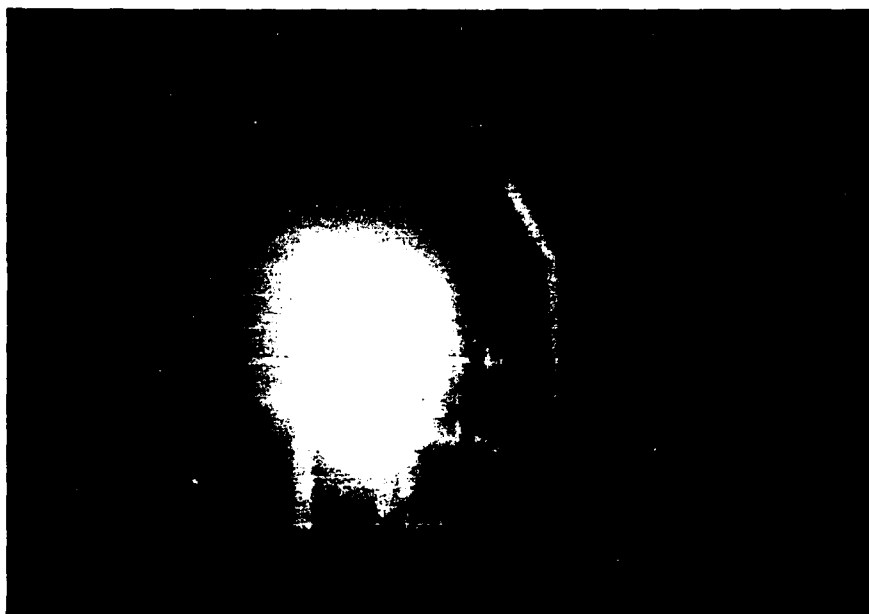
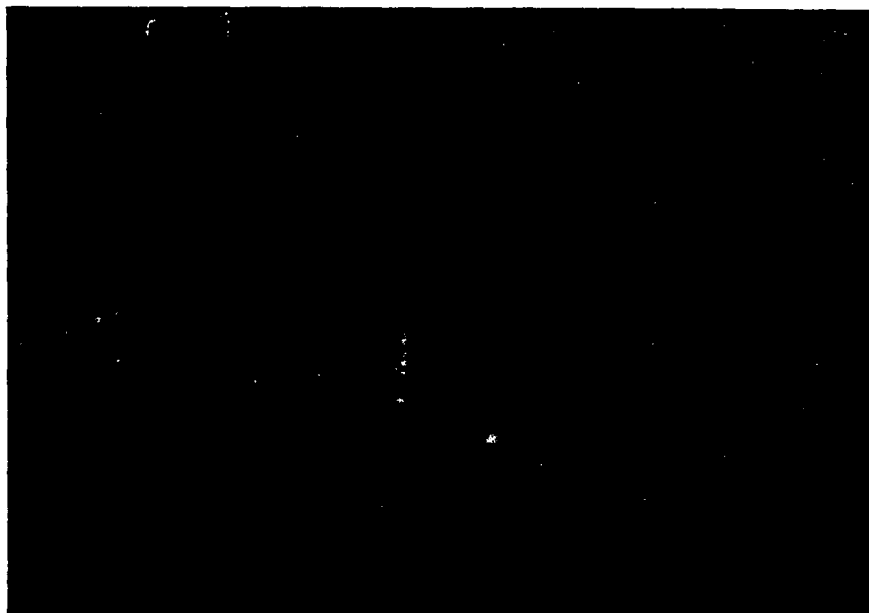

Figure V.1 Consecutive shots from VL361

THIS IS A BLANK PAGE

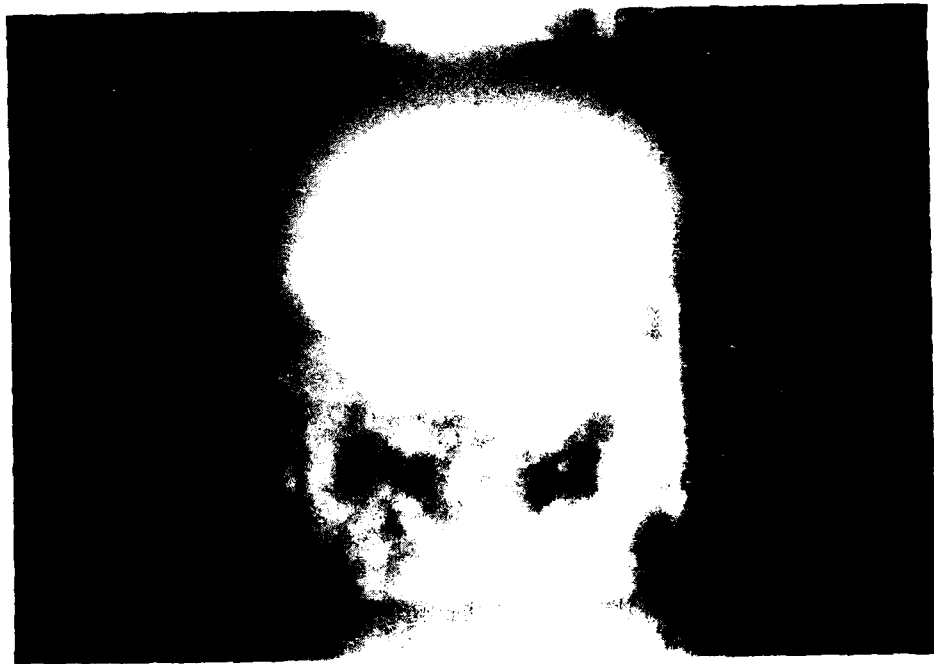
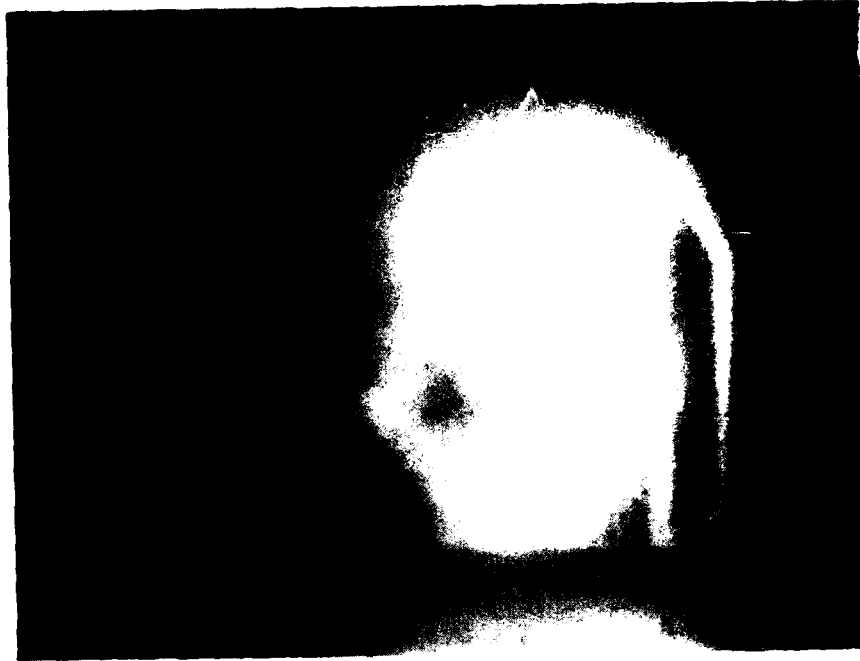

Figure V.1(Contd.).

THIS IS A BLANK PAGE

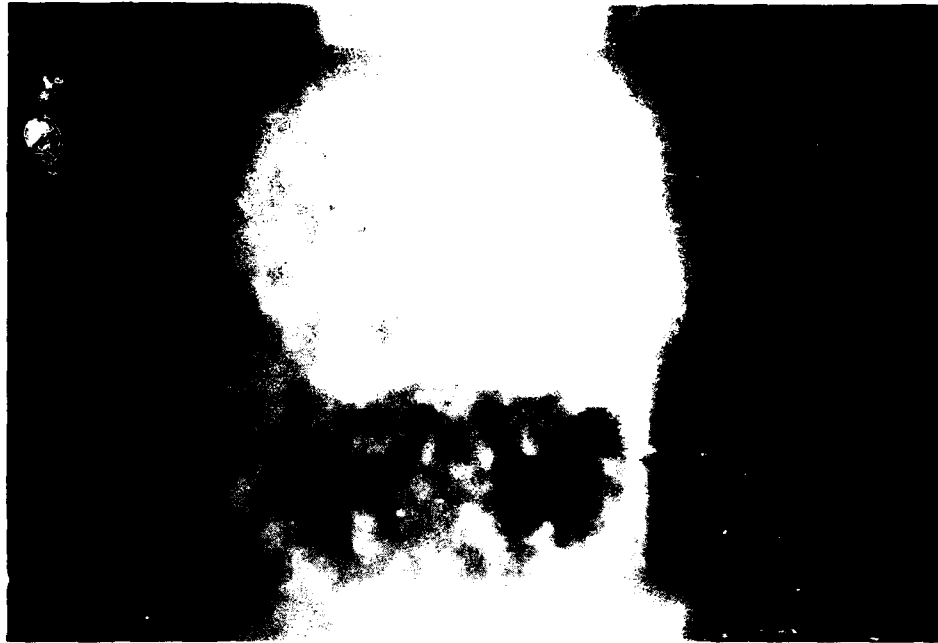

Figure V.1(Contd.).

THIS IS A BLANK PAGE

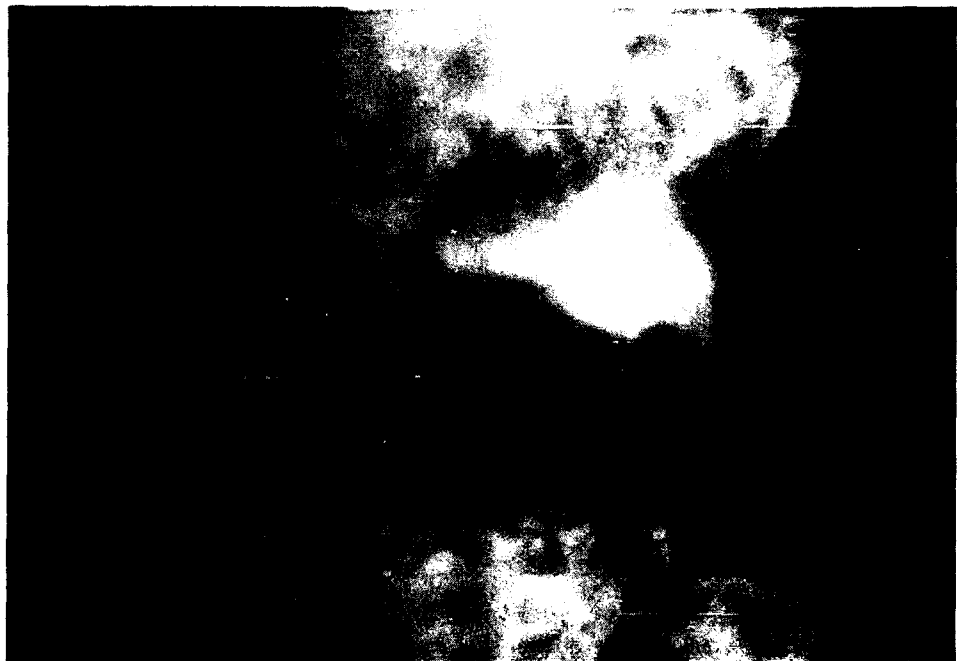
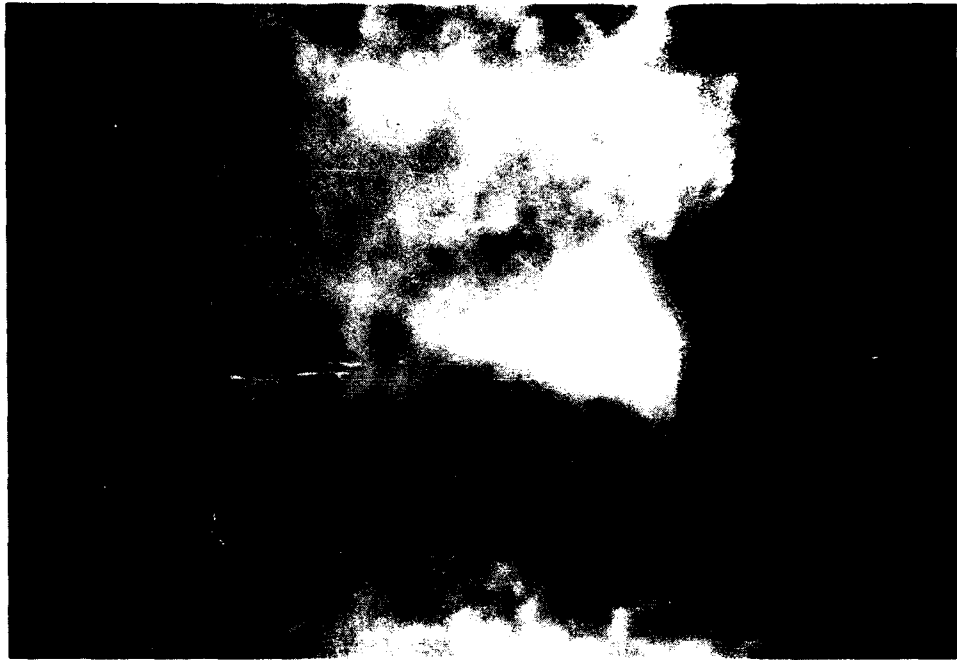

Figure V.1(Contd.).

THIS IS A BLANK PAGE

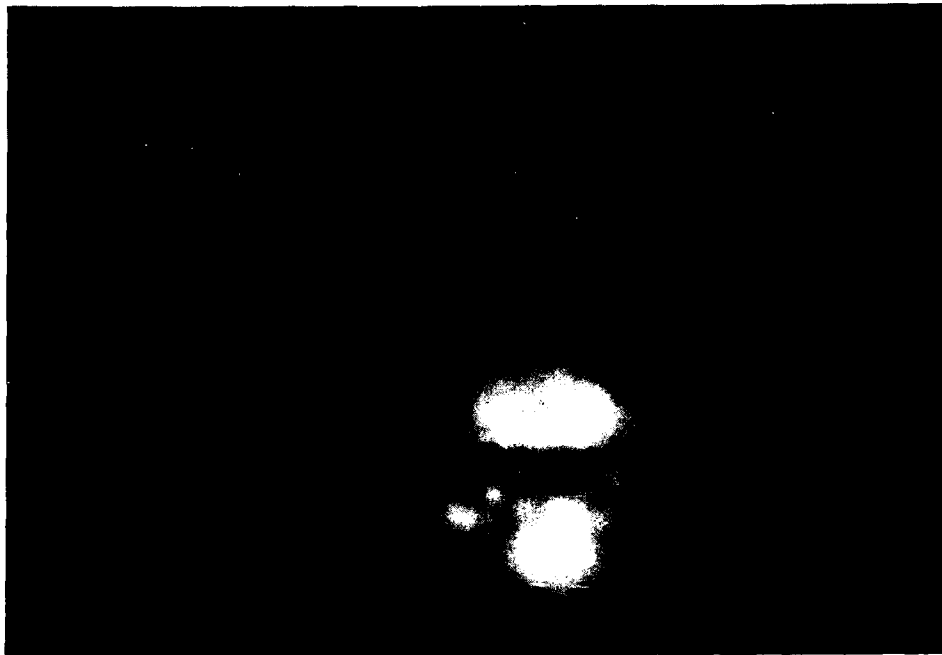

Figure V.2 Consecutive shots from V1.562

THIS IS A BLANK PAGE



Figure V.2(Contd.).

THIS IS A BLANK PAGE



Figure V.2(Contd.).

THIS IS A BLANK PAGE

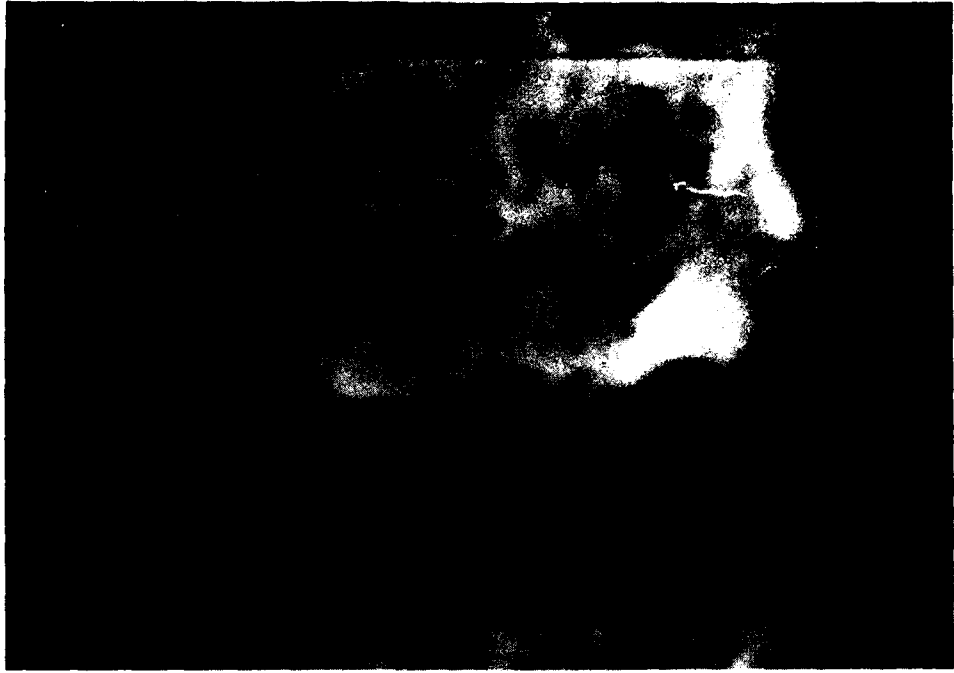

Figure V.2(Contd.).

THIS IS A BLANK PAGE

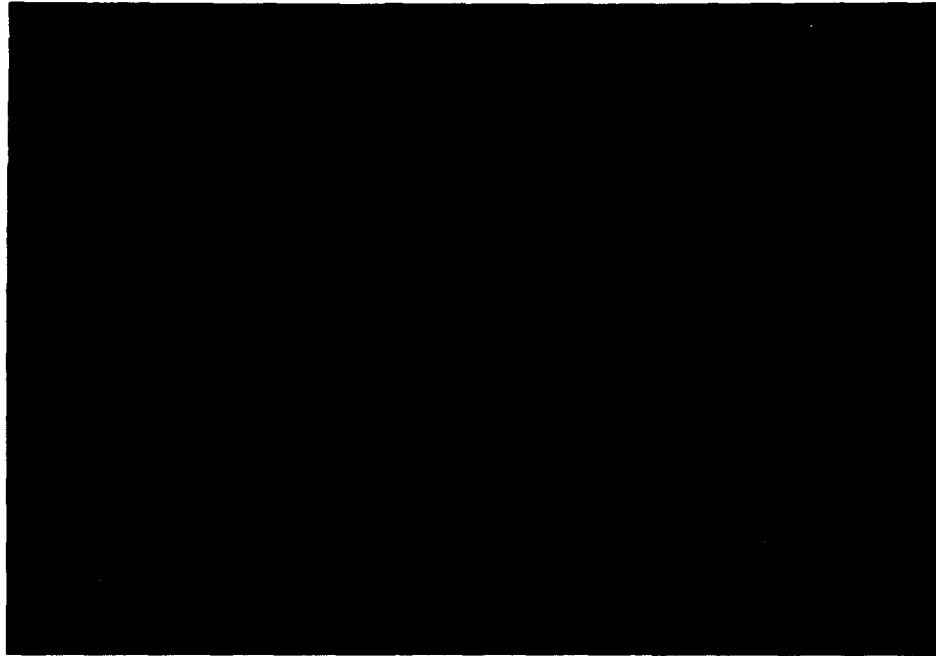

Figure V.3 Consecutive shots from VL363

THIS IS A BLANK PAGE

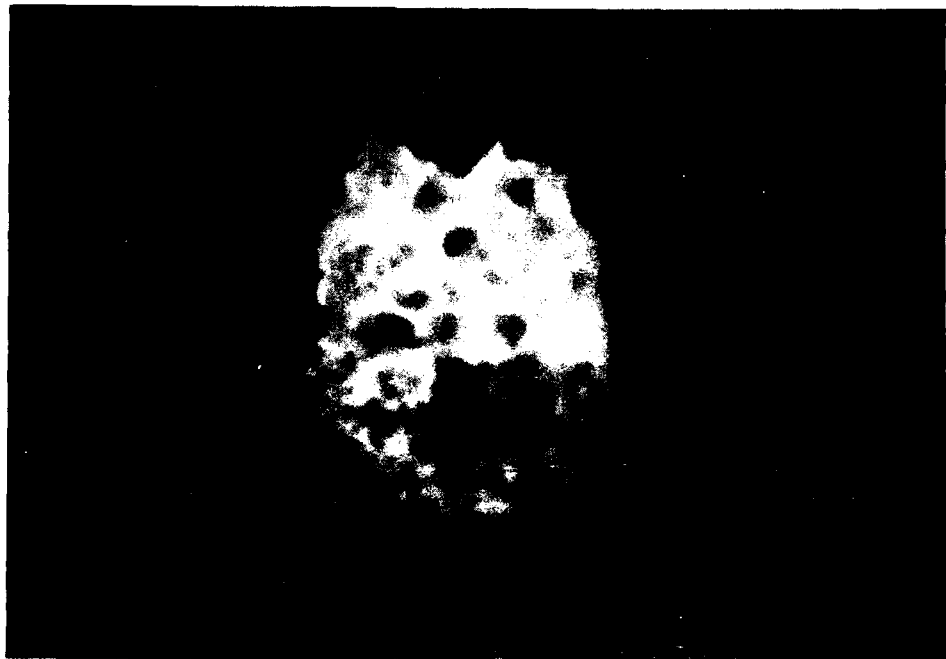

Figure V.3(Contd. 1).

THIS IS A BLANK PAGE

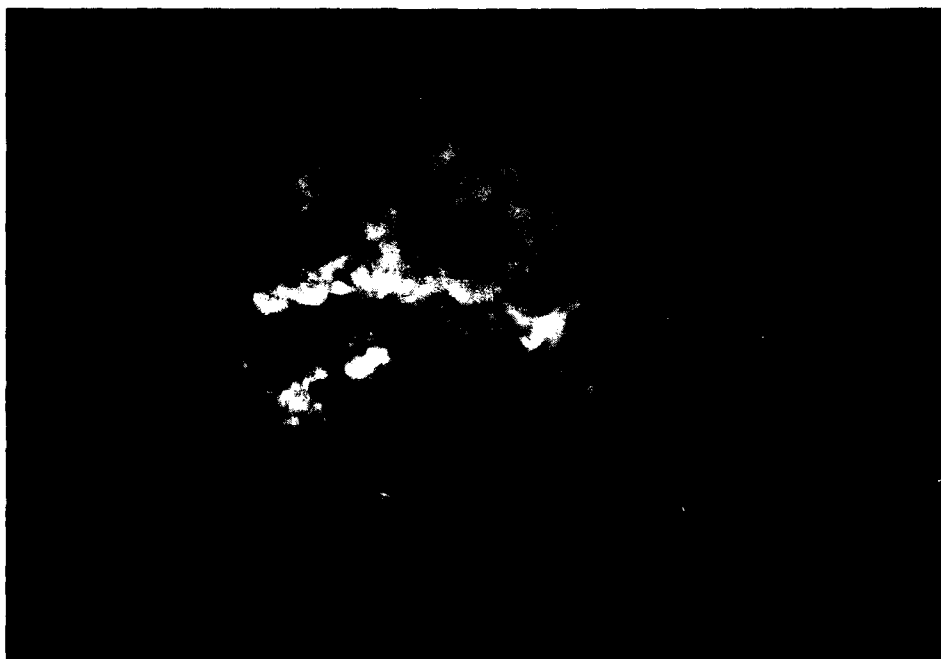
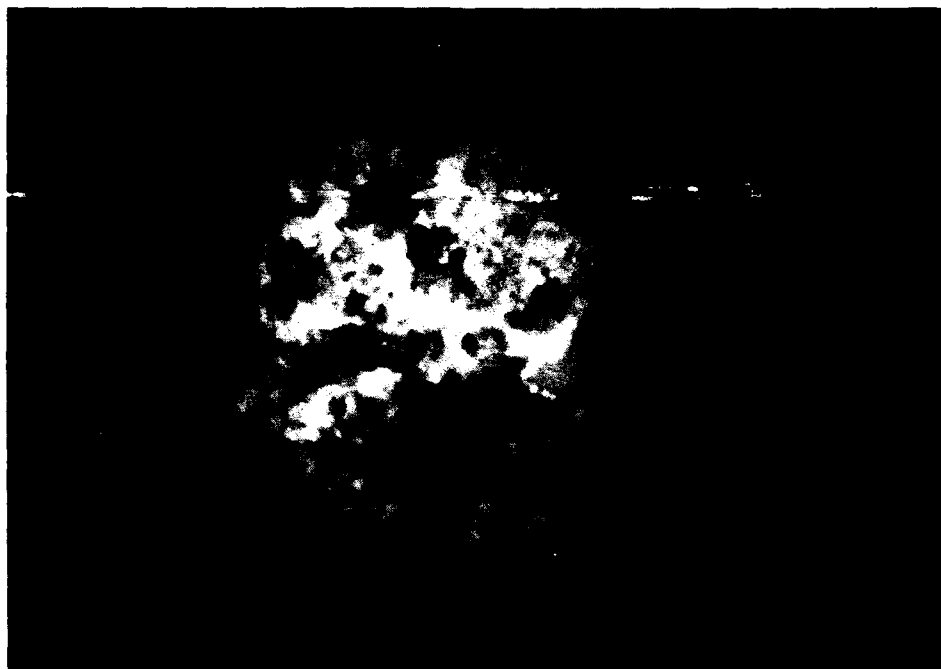

Figure V.3(Contd.).

THIS IS A BLANK PAGE

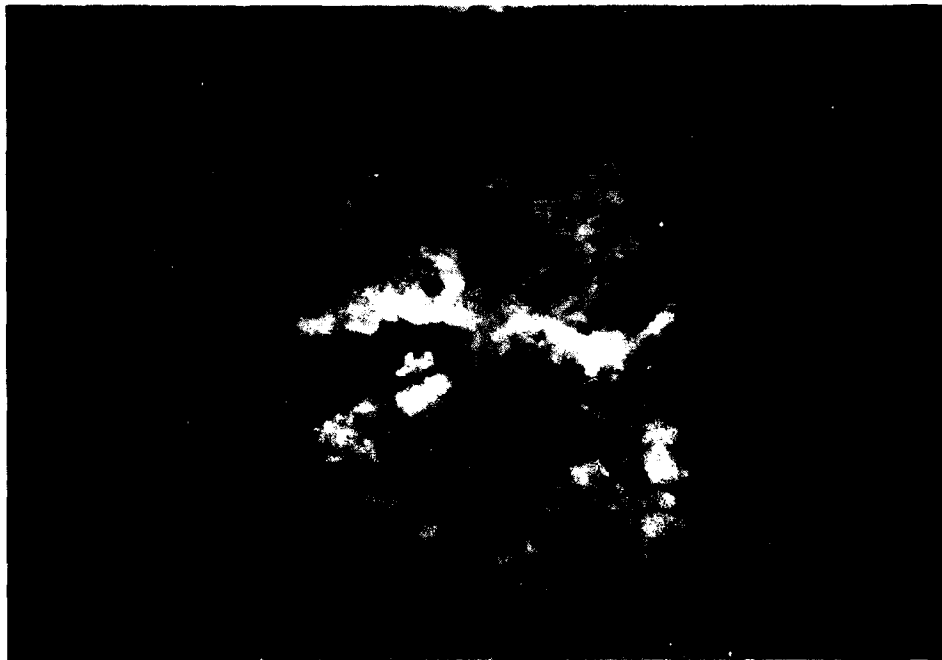
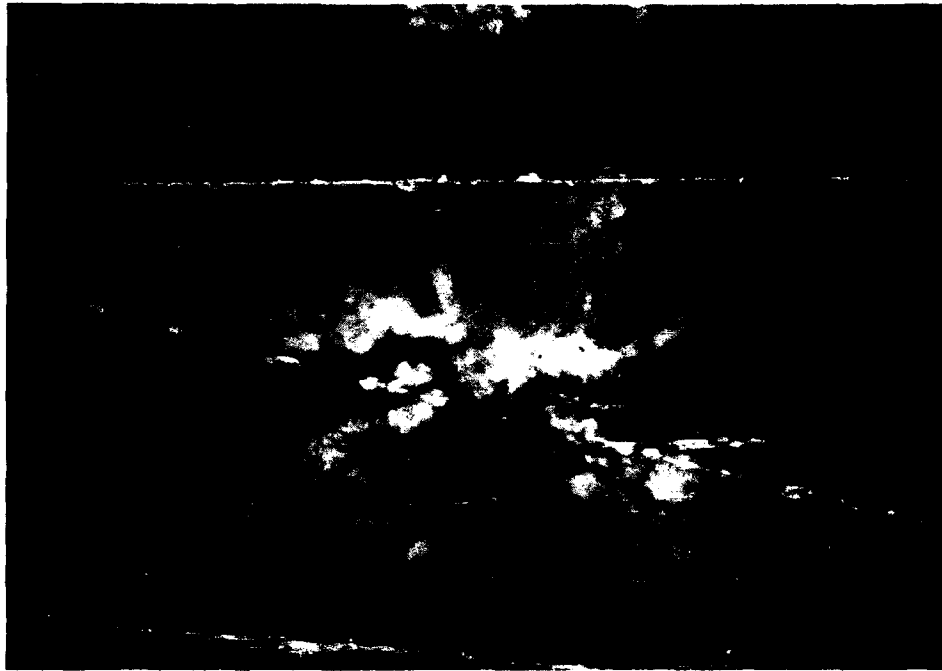

Figure V. (Cont'd.)

THIS IS A BLANK PAGE

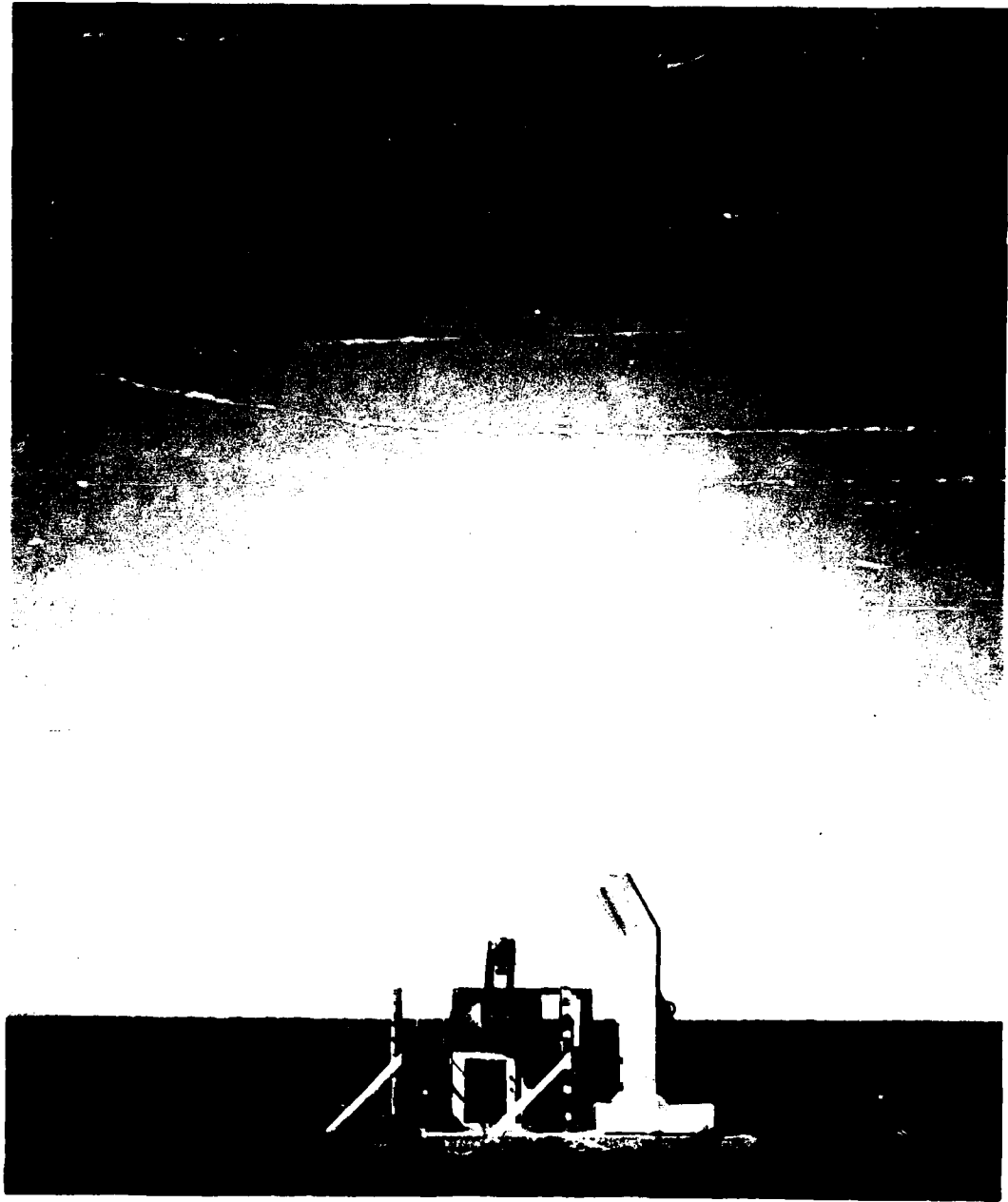

Figure V.4 Consecutive shots from VL364

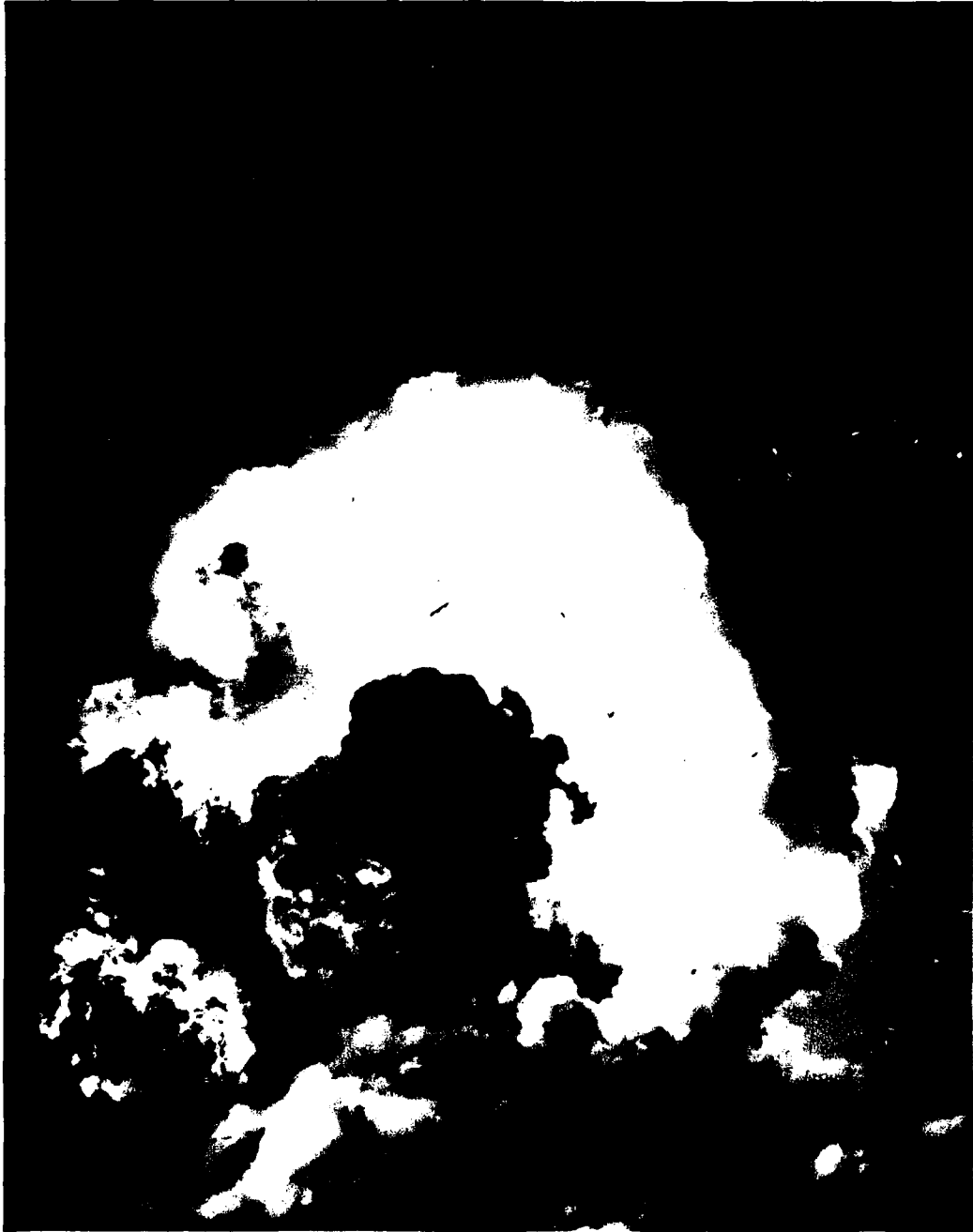

Figure V.4(Contd.).

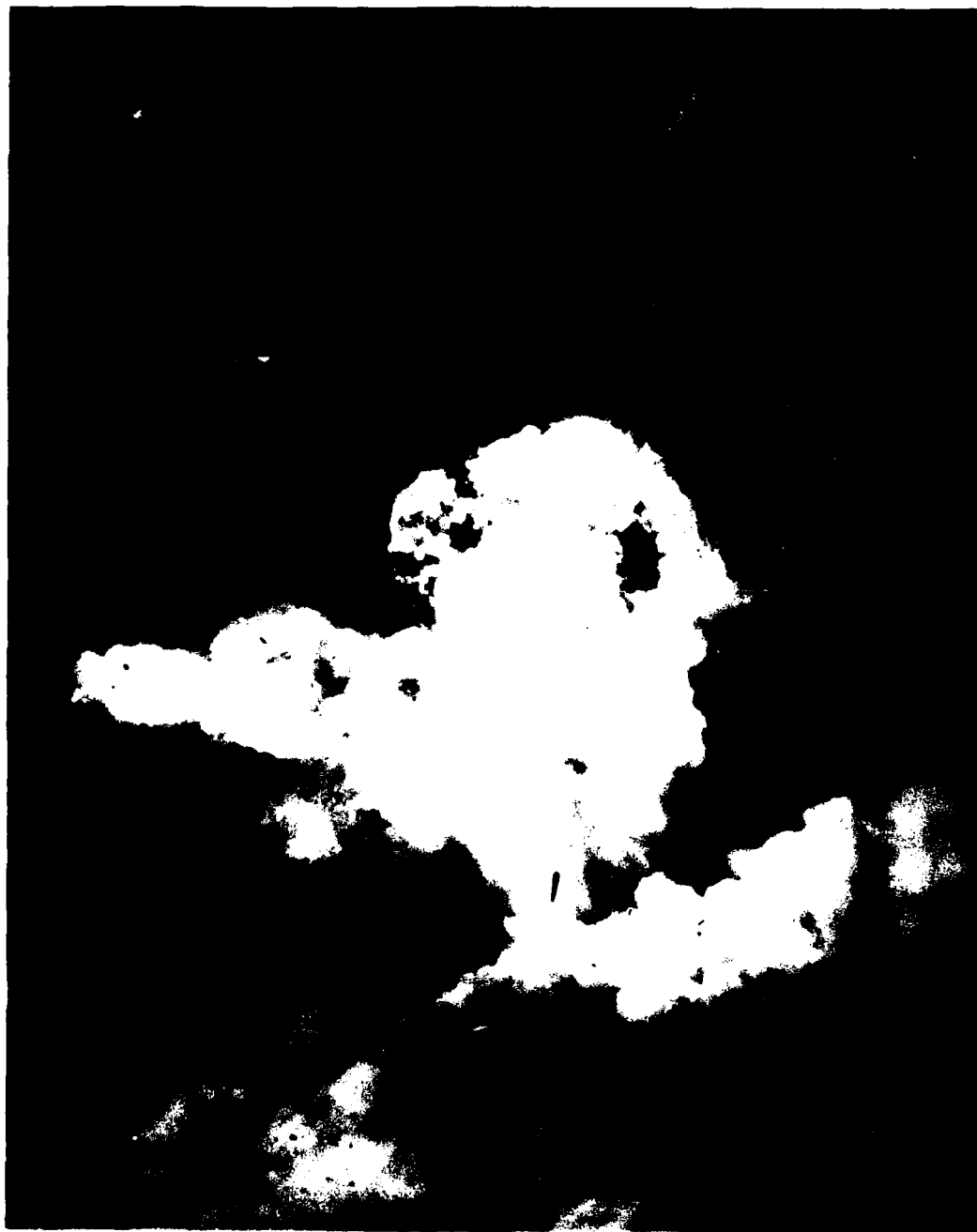

Figure V.4(Contd.).

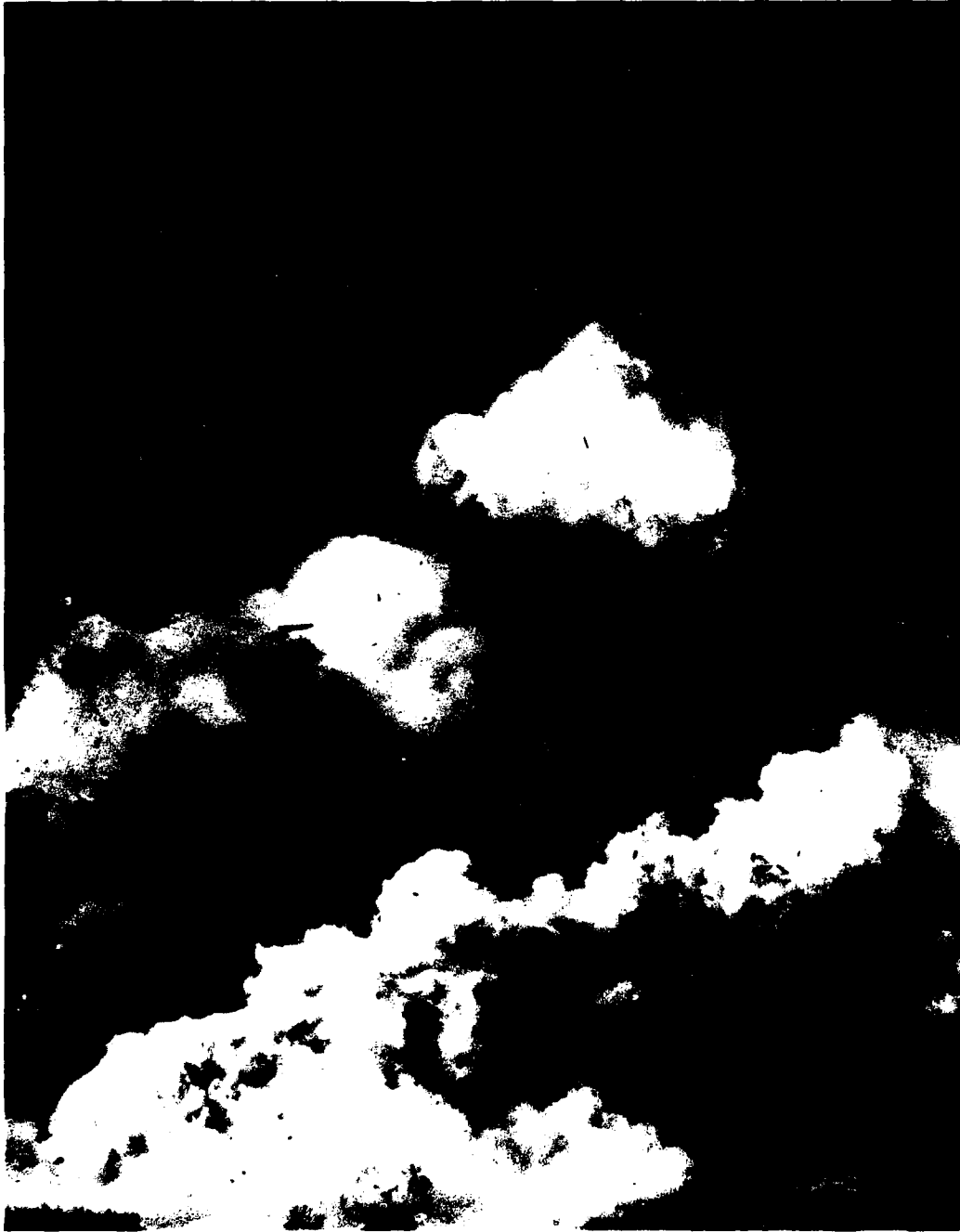

Figure V.4(Contd.).



Figure V.4(Contd.).



Figure V.4(Contd.).

THIS IS A BLANK PAGE

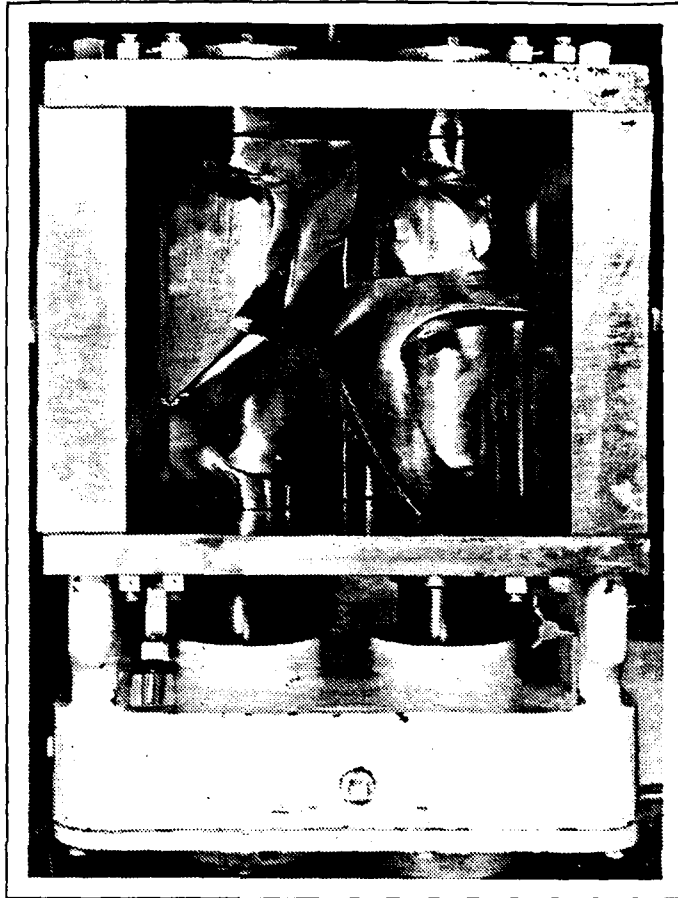

Plate 1. Starr mixer

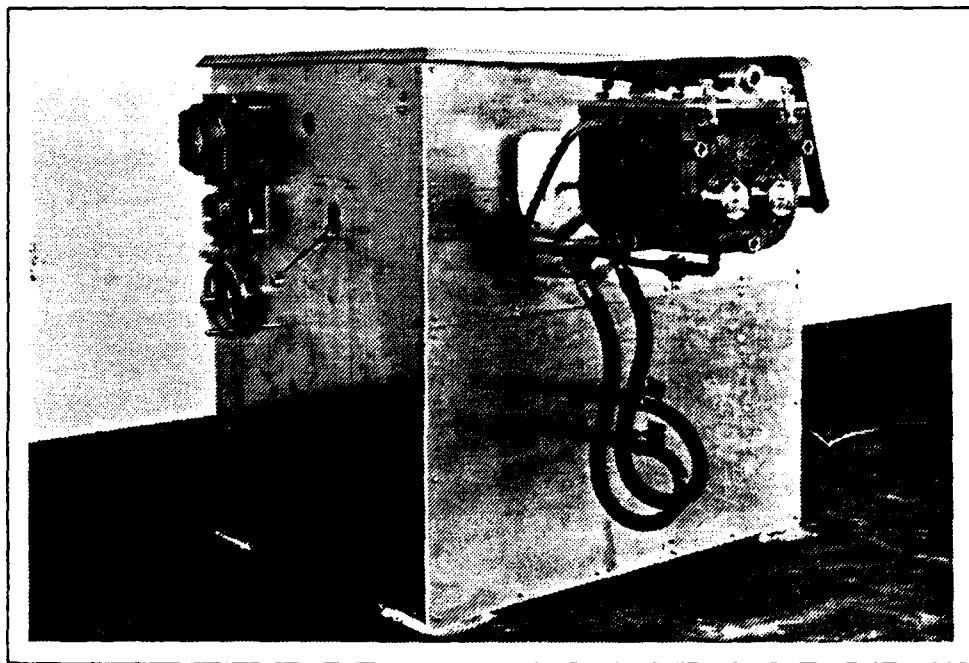

Plate 2. Starr mixer

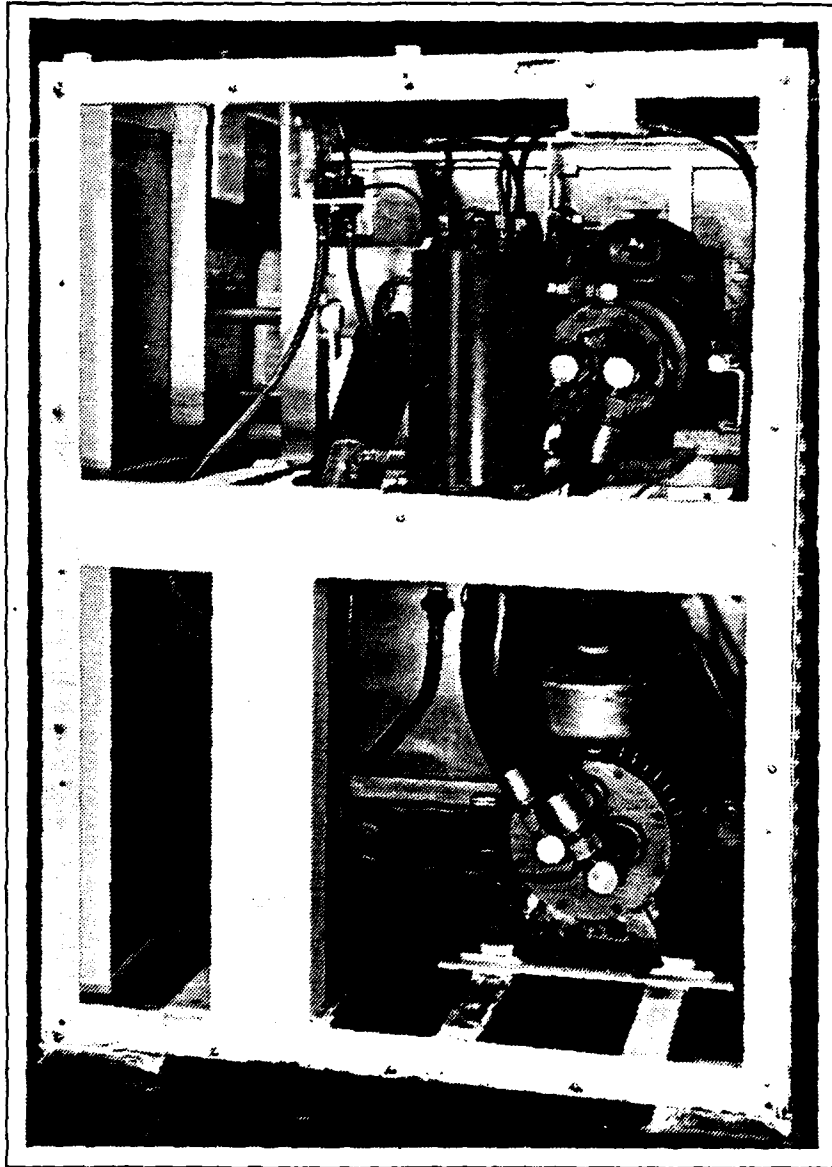

Plate 3. Starr mixer

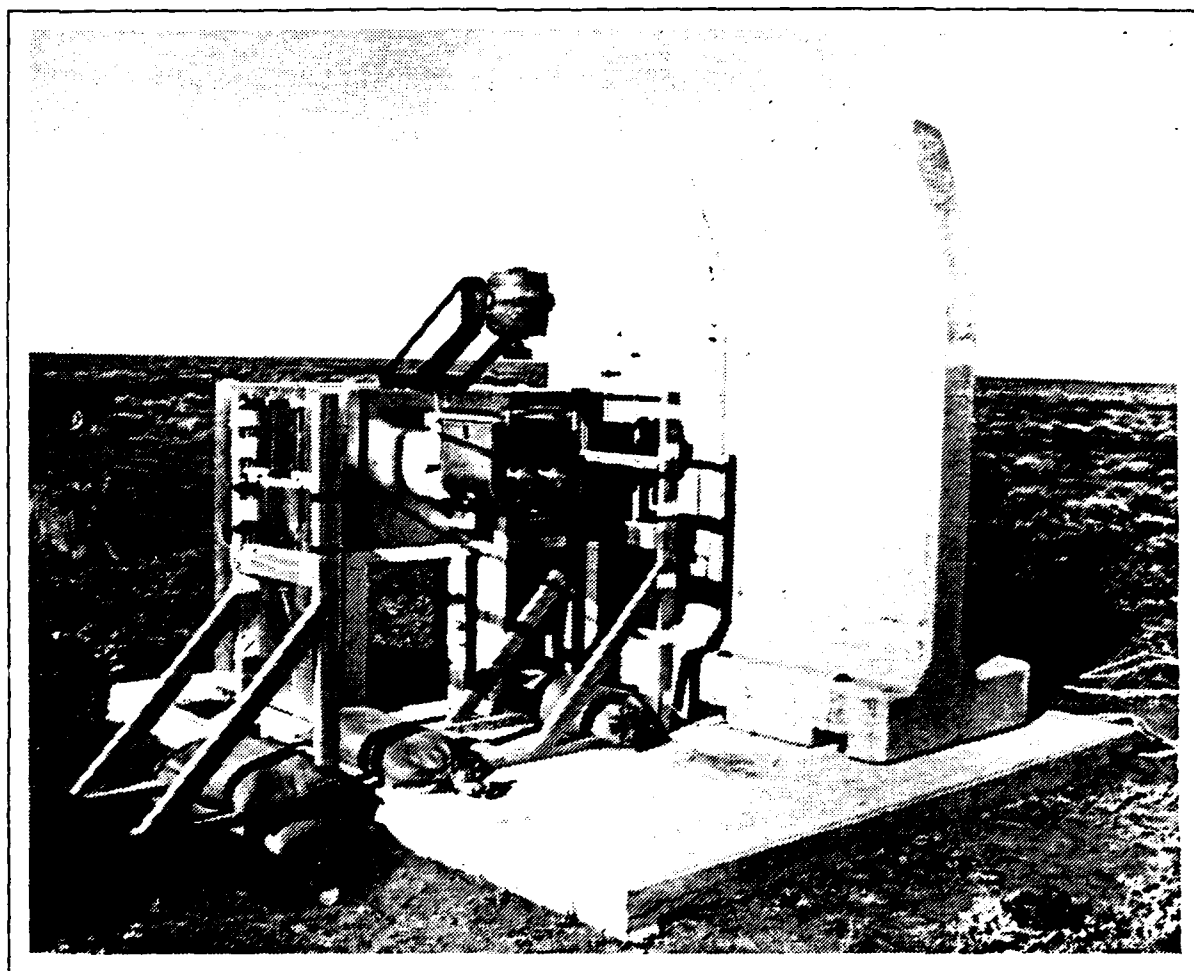

Plate 4. Pre-explosion site arrangement

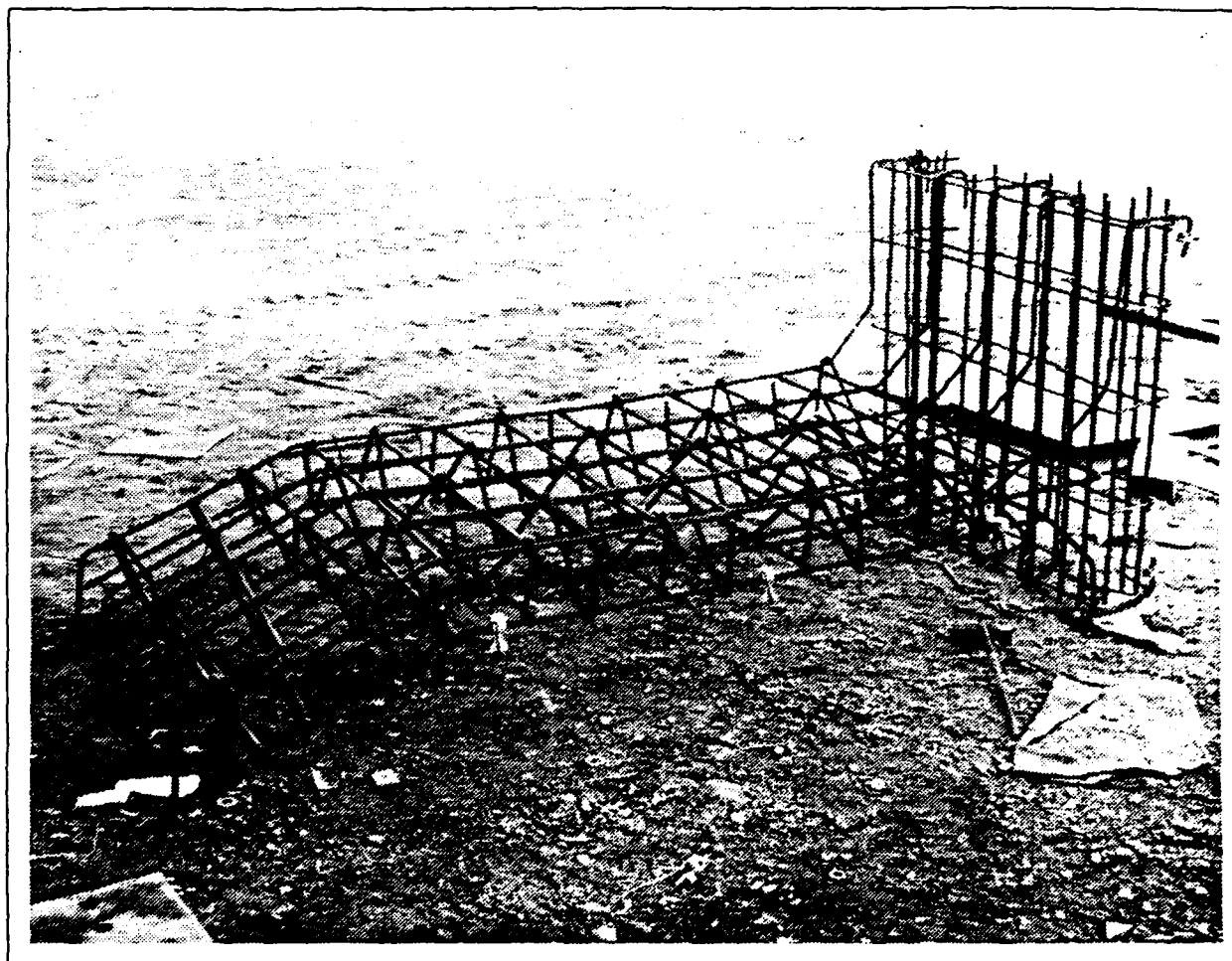

Plate 5. Mesh reinforcing

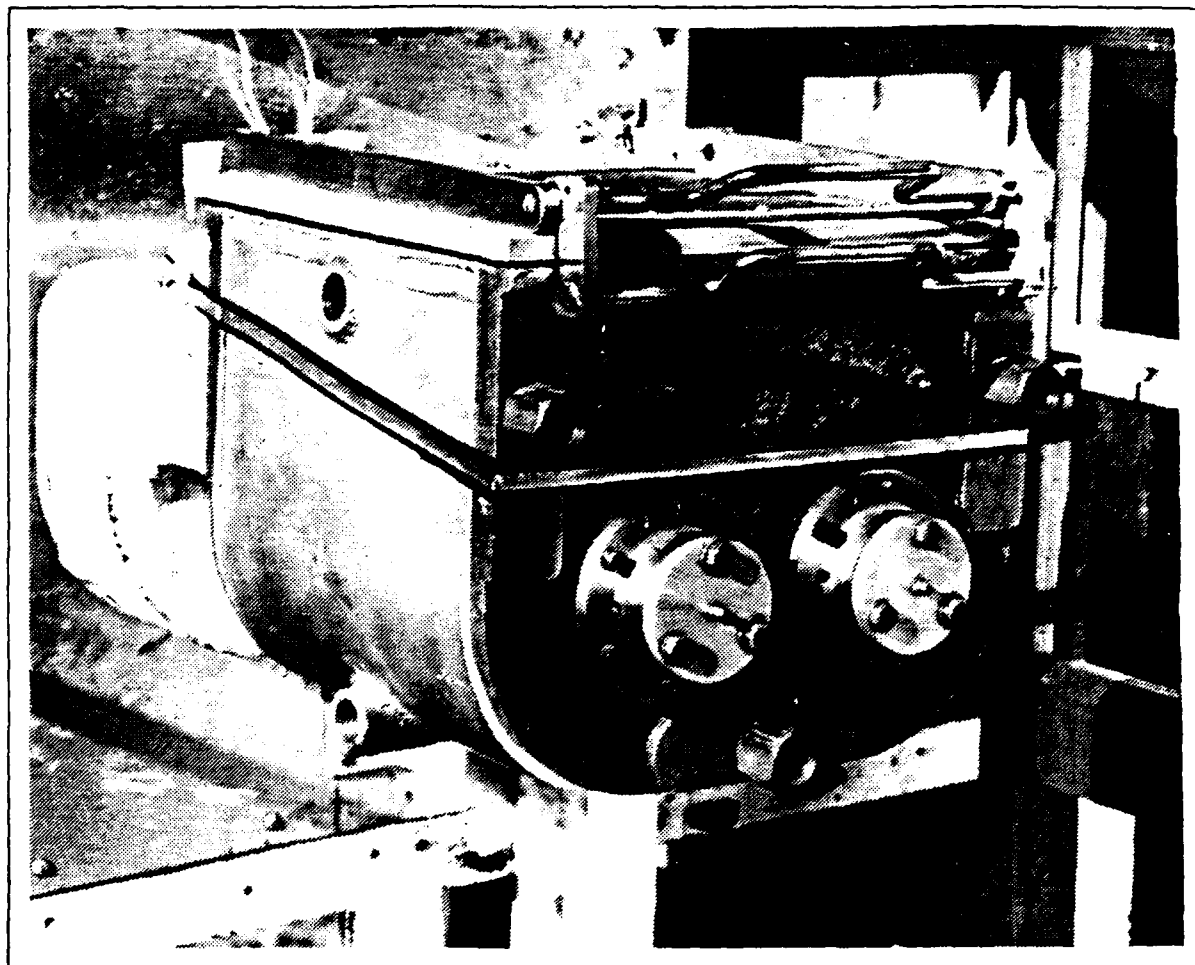

Plate 6. Starr mixer bowl showing electrical foil

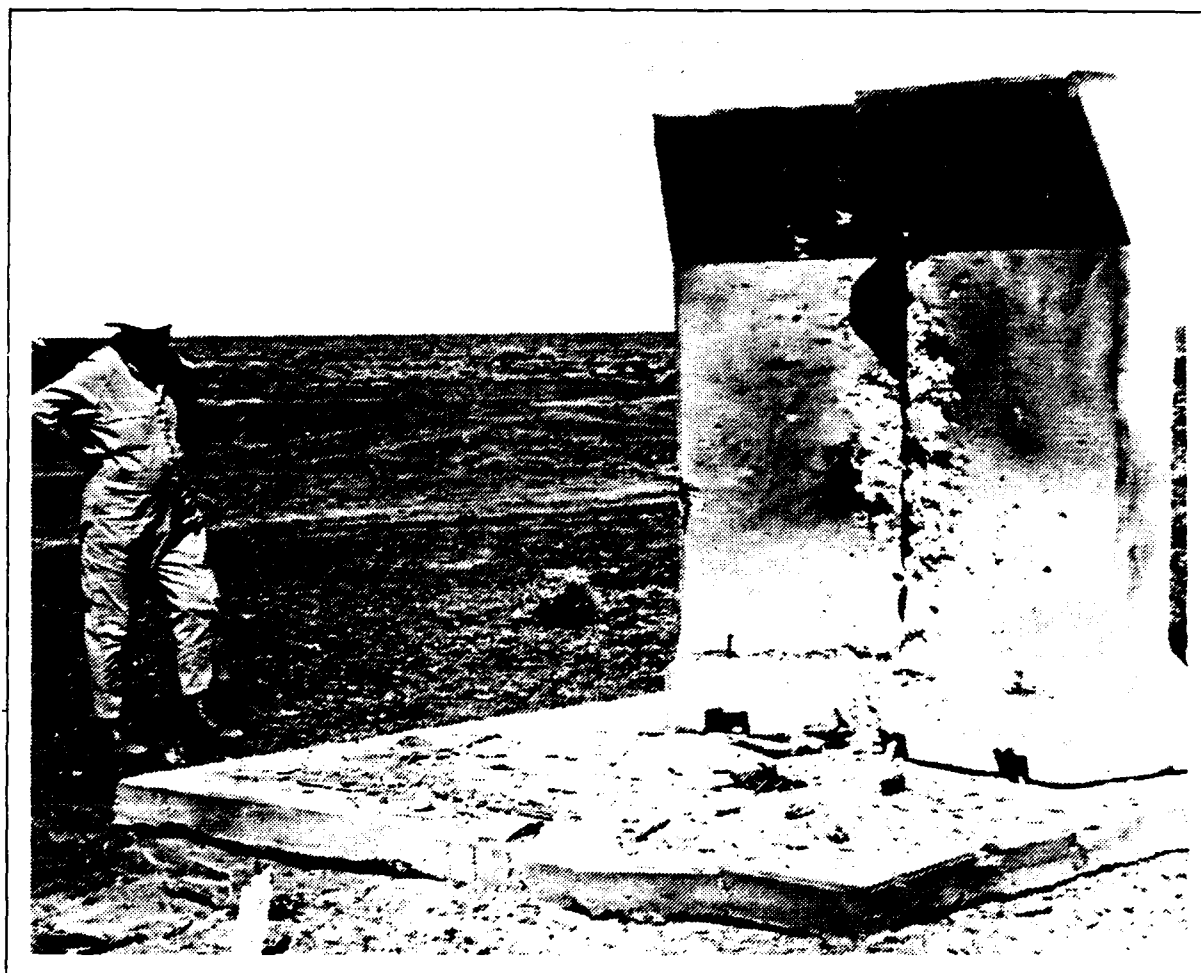

Plate 7. Post-explosion site view

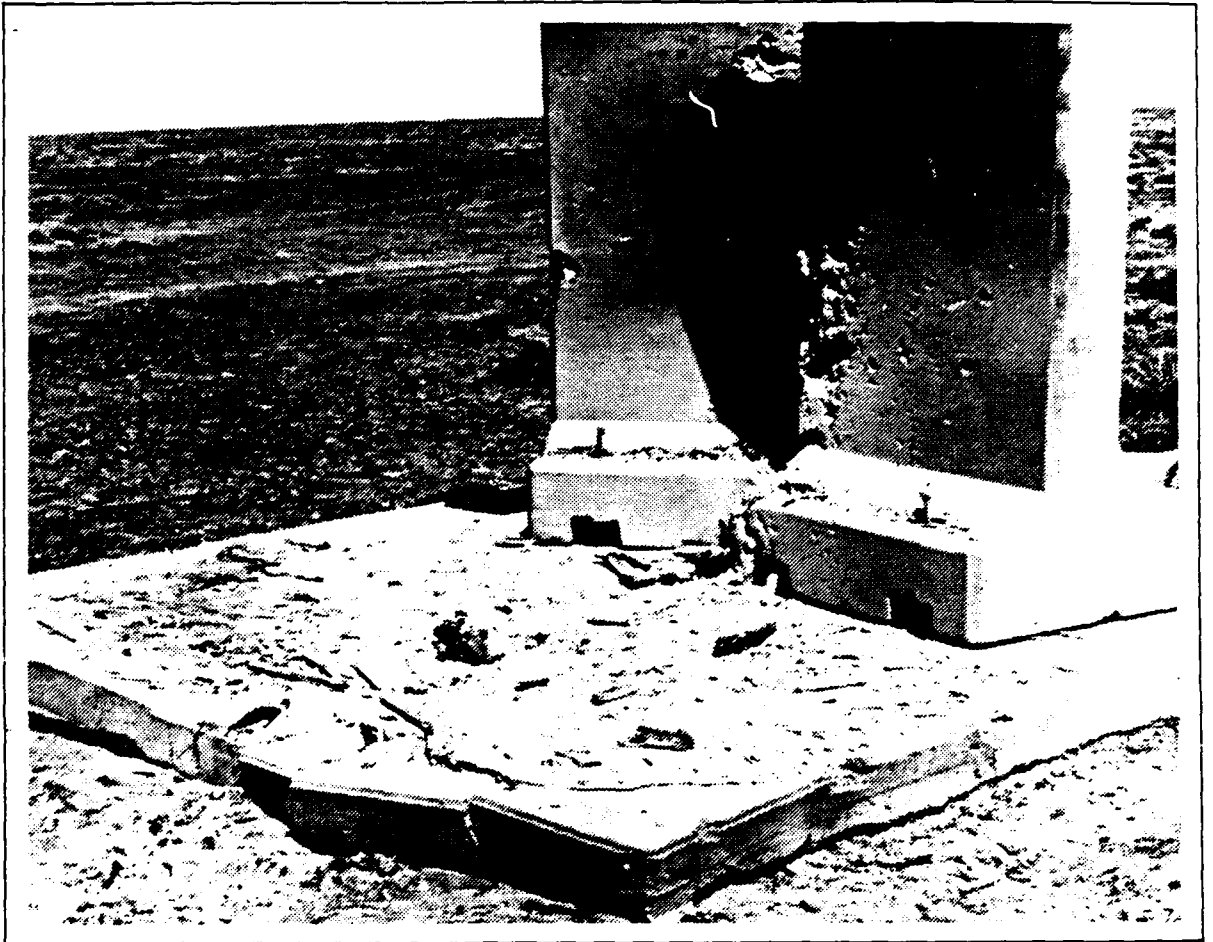

Plate 8. Post-explosion site view



Plate 9. Front faces of wall modules

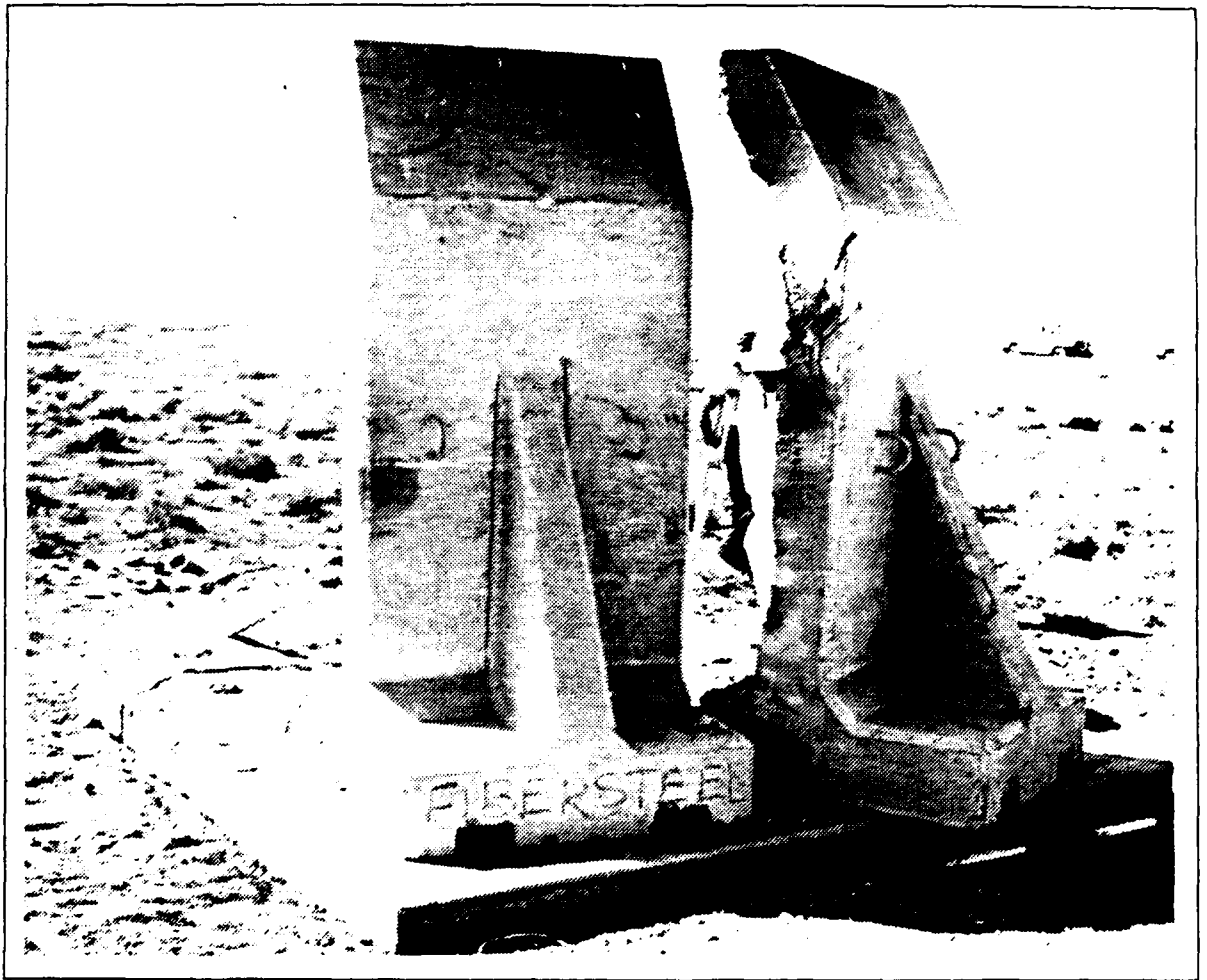

Plate 10. Rear view faces of wall modules

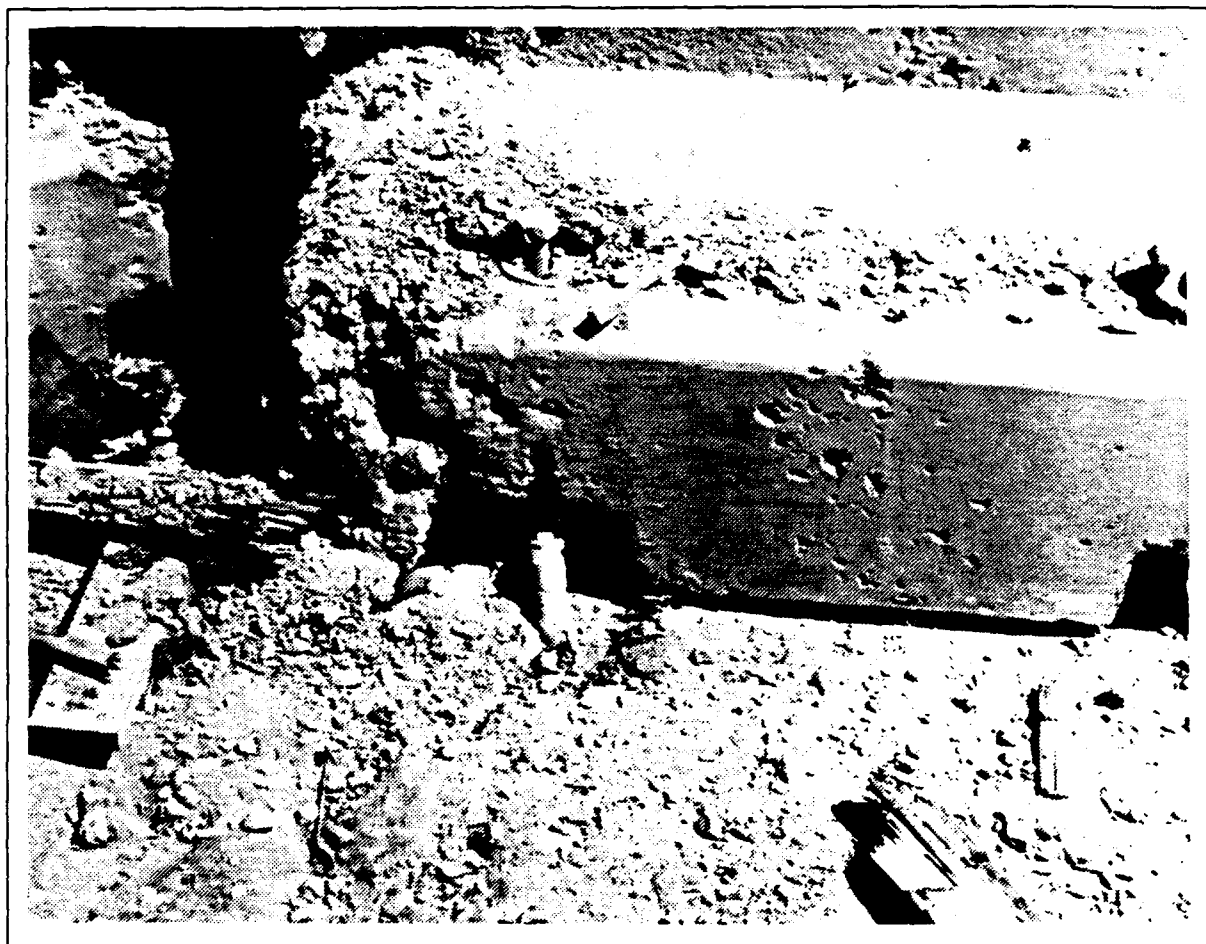

Plate 11. Dislodged anchor bolt



Plate 12. Fibrecrete front face pitting

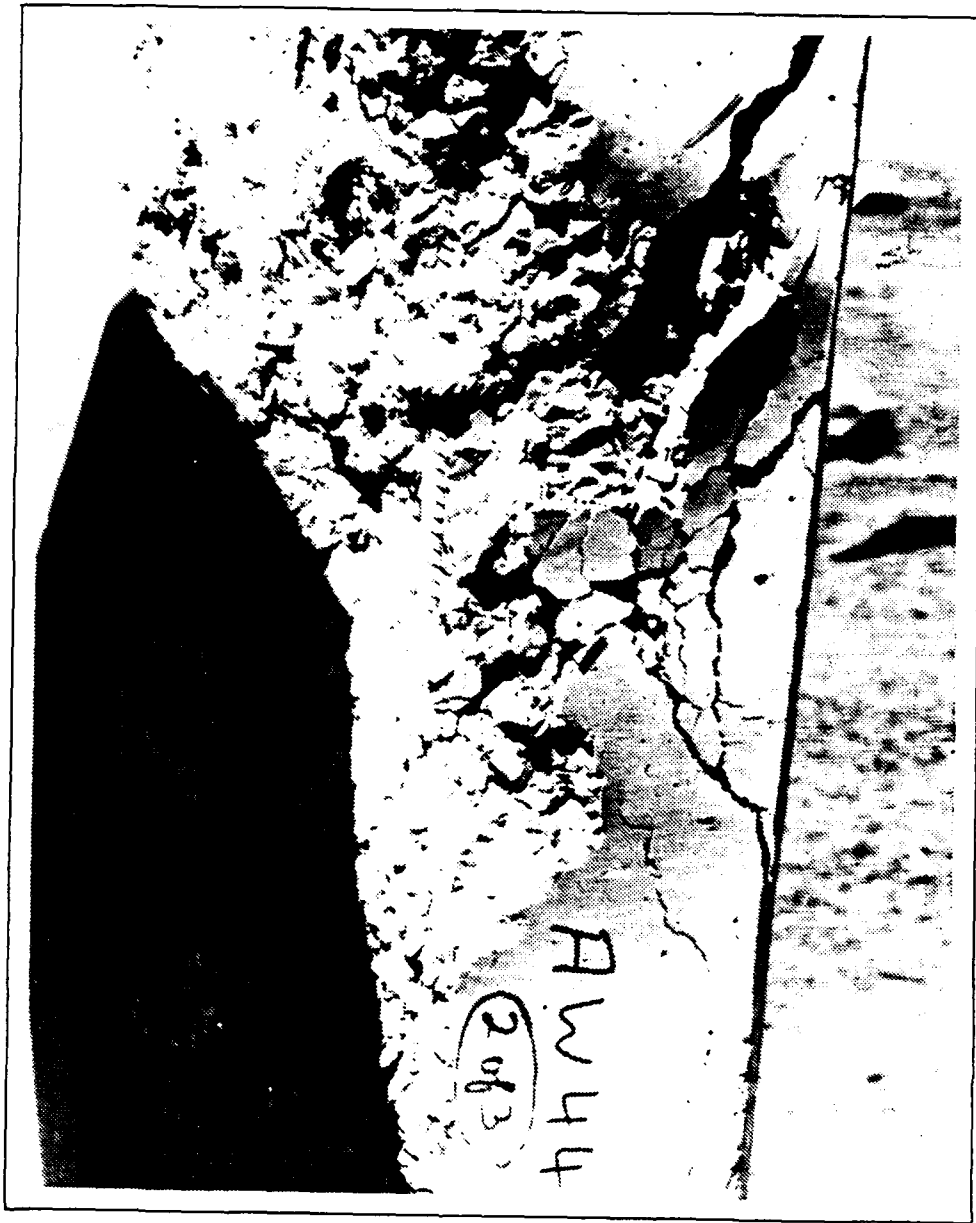

Plate 13. Approach to separation

## DISTRIBUTION

No. of copies

Defence Science and Technology Organization	
Chief Defence Scientist	} 1
First Assistant Secretary Science Policy	
First Assistant Secretary Science Corporate Management	
Director General Science and Technology Programs	
Counsellor, Defence Science, London	Cnt Sht Only
Counsellor, Defence Science, Washington	Cnt Sht Only
Defence Science Representative, Bangkok	Cnt Sht Only
Defence Advisor Defence Research Centre, Kuala Lumpur	Cnt Sht Only
Weapons Systems Research Laboratory	
Director, Weapons Systems Research Laboratory	1
Chief, Ordnance Systems Division	11
Research Leader, Ballistic Weapons and Propulsion	1
Dr I. Napier, Ordnance Systems Division	1
Mr B.L Hamshere, Ordnance Systems Division	1
Mr J. Hooper, Ordnance Systems Division	1
Mr N.V. Ayres, Ordnance Systems Division	1
Mr B. Soulsby, Ordnance Systems Division	1
Authors	4
Materials Research Laboratory	
Director, Materials Research Laboratory	1
Chief, Explosives Division	1
Research Leader, Explosives	1
Libraries and Information Services	
Librarian, Technical Reports Centre, Defence Central Library, Campbell Park	1

Document Exchange Centre

Defence Information Services Branch for:

Microfiche copying	1
United Kingdom, Defence Research Information Centre	2
United States, Defense Technical Information Center	12
Canada, Director Scientific Information Services	1
New Zealand, Ministry of Defence	1
National Library of Australia	1

Defence Science and Technology Organisation Salisbury

Main Library	2
OSD Library	1
Library, DSD, Melbourne	1
Library, Materials Research Laboratory	1
Libraries, Office of Defence Production	
Library, Anzac Park West	1
Library, Explosives Factory Maribyrnong	1
Library, Mulwala Explosives Factory	1
Library, Albion Explosives Factory	1
Library, Production Development Facility, Salisbury	1
Australian Defence Force Academy Library	1

The Technical Cooperation Program (TTCP)

Australian National Leader WTP-4, for distribution to:

UK National Leader WTP-4	2
CA National Leader WTP-4	2
US National Leader WTP-4	2

Department of Defence

Director of Departmental Publications	1
Joint Intelligence Organization (DSTI)	1
Australian Ordnance Council	
President	1
Secretary, Explosives Storage and Transport Committee	1

Navy Office	
Navy Scientific Adviser	Cnt Sht Only
Army Office	
Scientific Adviser - Army	1
Air Office	
Air Force Scientific Adviser	1
SEXPLENG, No 1 Central Ammunition Depot, Kingswood	1
Office of Defence Production	
First Assistant Secretary, Production Division	1
Special Adviser, Production	1
Assistant Secretary, Technology and Planning Branch	1
General Manager, Mulwala Explosives Factory	1
General Manager, Explosives Factory Maribyrnong	1
General Manager, Albion Explosives Factory	1
Manager, Project REFA, Explosives Factory Maribyrnong	1
Commander, Headquarters, 3th Military Dist, Perth	1
Spares	3
Total number of copies	80

DOCUMENT CONTROL DATA SHEET

Security classification of this page :

UNCLASSIFIED

1 DOCUMENT NUMBERS

AR  
Number: AR-005-434

Series  
Number: WSRL-TR-44/88

Other  
Numbers:

2 SECURITY CLASSIFICATION

a. Complete Document: Unclassified  
b. Title in isolation: Unclassified  
c. Summary in Isolation: Unclassified

3 DOWNGRADING / DELIMITING INSTRUCTIONS

4 TITLE

THE CONTAINMENT CHARACTERISTICS OF A PORTABLE REINFORCED CONCRETE WALL UNIT IN A SMALL EXPLOSIVES INCIDENT

5 PERSONAL AUTHOR (S)

M.J. Bone and  
B. Henderson

6 DOCUMENT DATE

September 1988

7 7.1 TOTAL NUMBER OF PAGES 72

7.2 NUMBER OF REFERENCES 4

8 8.1 CORPORATE AUTHOR (S)

Weapons Systems Research Laboratory

8.2 DOCUMENT SERIES and NUMBER  
Technical Report  
44/88

9 REFERENCE NUMBERS

a. Task:  
b. Sponsoring Agency:

10 COST CODE

11 IMPRINT (Publishing organisation)

Defence Science and Technology Organization

12 COMPUTER PROGRAM (S)  
(Title (s) and language (s))

13 RELEASE LIMITATIONS (of the document)

Approved for Public Release.

Security classification of this page :

UNCLASSIFIED

## 14 ANNOUNCEMENT LIMITATIONS (of the information on these pages)

No limitation

## 15 DESCRIPTORS

a. EJC Thesaurus Terms	Reinforced concrete Explosions Fragments Containment
------------------------	---

b. Non - Thesaurus Terms

## 16 COSATI CODES

0079E

## 17 SUMMARY OR ABSTRACT

(if this is security classified, the announcement of this report will be similarly classified)

→ An experiment was conducted in September 1987 at Woomera, to test the effectiveness of a reinforced concrete wall module. Wall modules, one designed to TM-5-1300 (an American design code) and another variant, were positioned close to a propellant incorporator loaded with 10 kg NEQ of explosives. The mixer contents were detonated.

Subsequent examination of the site enabled conclusions to be drawn on the adequacy of the design and the effectiveness of the wall modules as lethal fragment reflectors.

*Keywords; Australia; Lead sheets; explosion shields; (KT) a*