

AEDC-TR-89-6

C#3

Wide-Range Fuel Flowmeter

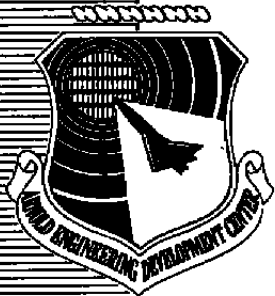

William Seiler, Jr.
Waugh Controls Corp.
Chatsworth, CA 91311

July 1989

Final Report for Period June 4, 1986 – February 1988

Approved for public release; distribution is unlimited.

**TECHNICAL REPORTS
FILE COPY**

**PROPERTY OF U.S. AIR FORCE
AEDC TECHNICAL LIBRARY**

**ARNOLD ENGINEERING DEVELOPMENT CENTER
ARNOLD AIR FORCE BASE, TENNESSEE
AIR FORCE SYSTEMS COMMAND
UNITED STATES AIR FORCE**

NOTICES

When U. S. Government drawings, specifications, or other data are used for any purpose other than a definitely related Government procurement operation, the Government thereby incurs no responsibility nor any obligation whatsoever, and the fact that the Government may have formulated, furnished, or in any way supplied the said drawings, specifications, or other data, is not to be regarded by implication or otherwise, or in any manner licensing the holder or any other person or corporation, or conveying any rights or permission to manufacture, use, or sell any patented invention that may in any way be related thereto.

Qualified users may obtain copies of this report from the Defense Technical Information Center.

References to named commercial products in this report are not to be considered in any sense as an endorsement of the product by the United States Air Force or the Government.

This report has been reviewed by the Office of Public Affairs (PA) and is releasable to the National Technical Information Service (NTIS). At NTIS, it will be available to the general public, including foreign nations.

APPROVAL STATEMENT

This report has been reviewed and approved.

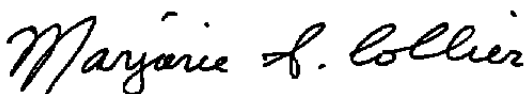

MARJORIE S. COLLIER
Directorate of Technology
Deputy for Operations

Approved for publication:

FOR THE COMMANDER



KEITH L. KUSHMAN
Technical Director
Directorate of Technology
Deputy for Operations

UNCLASSIFIED

SECURITY CLASSIFICATION OF THIS PAGE

REPORT DOCUMENTATION PAGE				Form Approved OMB No. 0704-0188		
1a. REPORT SECURITY CLASSIFICATION Unclassified			1b. RESTRICTIVE MARKINGS			
2a. SECURITY CLASSIFICATION AUTHORITY			3. DISTRIBUTION/AVAILABILITY OF REPORT Approved for public release; distribution is unlimited.			
2b. DECLASSIFICATION/DOWNGRADING SCHEDULE						
4. PERFORMING ORGANIZATION REPORT NUMBER(S) AEDC-TR-89-6			5. MONITORING ORGANIZATION REPORT NUMBER(S)			
6a. NAME OF PERFORMING ORGANIZATION Waugh Controls Corporation		6b. OFFICE SYMBOL (if applicable)	7a. NAME OF MONITORING ORGANIZATION			
6c. ADDRESS (City, State, and ZIP Code) 9001 Fullbright Avenue Chatsworth, CA 91311			7b. ADDRESS (City, State, and ZIP Code)			
8a. NAME OF FUNDING/SPONSORING ORGANIZATION Arnold Engineering Development Center		8b. OFFICE SYMBOL (if applicable) DOT	9. PROCUREMENT INSTRUMENT IDENTIFICATION NUMBER F40600-86-C0003			
8c. ADDRESS (City, State, and ZIP Code) Air Force Systems Command Arnold Air Force Base, TN 37389-5000			10. SOURCE OF FUNDING NUMBERS			
			PROGRAM ELEMENT NO. 65502F	PROJECT NO.	TASK NO.	WORK UNIT ACCESSION NO.
11. TITLE (Include Security Classification) Wide-Range Fuel Flowmeter						
12. PERSONAL AUTHOR(S) Seiler, William Jr., Waugh Controls Corp., Chatsworth, CA						
13a. TYPE OF REPORT Final		13b. TIME COVERED FROM 6/4/86 to 2/3/88		14. DATE OF REPORT (Year, Month, Day) July 1989	15. PAGE COUNT 117	
16. SUPPLEMENTARY NOTATION Available in Defense Technical Information Center (DTIC).						
17. COSATI CODES			18. SUBJECT TERMS (Continue on reverse if necessary and identify by block number) flowmeter fuel flowmeter wide range			
FIELD	GROUP	SUB-GROUP				
21	05					
21	07					
19. ABSTRACT (Continue on reverse if necessary and identify by block number) The Phase II Wide-Range Fuel Flowmeter (WRFF) development program is an extension of the Phase I program completed on 26 April 1985. This program proved the viability of the recirculation method of wide-range flow measurement over a 140 to 1 or greater range with a 1-percent or better measurement uncertainty. The objectives of the Phase II program were to: (1) Reduce the size of the flowmeter and electronic conditioner and provide a more functional and economically producible system; (2) Replace the recirculating pump with a smaller, more reliable unit and assure that all components in contact with the fluid are compatible with jet fuels; (3) Provide means to disable recirculating flow when operating at high flow rates; and (4) Evaluate the performance of an air-driven pump for possible use in hazardous atmospheres. The meter was redesigned to greatly reduce its size and weight; large and expensive manifolds were eliminated, and wherever possible, commercially available fittings were used. Inwardly pointing tubes were incorporated to inject and retrieve the recirculating flow.						
20. DISTRIBUTION/AVAILABILITY OF ABSTRACT <input type="checkbox"/> UNCLASSIFIED/UNLIMITED <input checked="" type="checkbox"/> SAME AS RPT <input type="checkbox"/> DTIC USERS			21. ABSTRACT SECURITY CLASSIFICATION Unclassified			
22a. NAME OF RESPONSIBLE INDIVIDUAL Mr. Carlton L. Garner			22b. TELEPHONE (Include Area Code) (615) 454-7813		22c. OFFICE SYMBOL DOCS	

DD Form 1473, JUN 86

Previous editions are obsolete.

SECURITY CLASSIFICATION OF THIS PAGE

UNCLASSIFIED

UNCLASSIFIED

19. ABSTRACT. Concluded.

reducing recirculation flow variation and related recirculation flow errors. The electronic conditioner was repackaged in a standard 3-1/2- by 19- in. rack mount.

An "auto-zero" feature was created and incorporated in the electronic conditioner, greatly simplifying and accelerating the zeroing process.

Testing was conducted to verify rangeability, transient response, long-term stability without re-zeroing, meter performance without recirculation, and performance using an air-driven pump.

UNCLASSIFIED

PREFACE

The work reported herein was conducted by Waugh Controls Corporation, Chatsworth, CA, for the Arnold Engineering Development Center (AEDC), Air Force Systems Command (AFSC) under contract F40600-86-C003. The Air Force Project Manager was Ms. Marjorie S. Collier, AEDC/DOI, and the Waugh Controls Corp. Project Manager was Mr. William Seiler, Jr. The reproducibles used in the reproduction of the report were provided by the author.

CONTENTS

Paragraph		Page
1	INTRODUCTION	1
1.1	Background	1
1.2	Theory of Operation	1
1.2.1	Wide Range Fuel Flowmeter	1
1.2.2	Signal Conditioner	3
2	OBJECTIVES	11
3	PROCEDURES	12
3.1	Pump Selection	12
3.2	Recirculation Injection & Recovery	13
3.3	WRFF Meter Design	24
3.4	WRFF Signal Conditioner Design	28
3.5	System Uncertainty Analysis	36
3.5.1	Flowmeter Repeatability	36
3.5.2	Scaler Zero Variation	37
4	TESTS PERFORMED	42
4.1	General	42
4.2	Mainstream Meter Calibration	43
4.3	WRFF System Calibration	43
4.4	Low Pressure Calibration	43
4.5	Stability Verification	44
4.6	Transient Response	45
4.6.1	Bench Test	46
4.6.2	System Test	46
4.7	Airmotor Pump Evaluation	46
5	TESTS RESULTS	49
5.1	General	49
5.2	Mainstream Meter Calibration	51
5.3	WRFF System Calibration	51
5.3.1	Recirculation Flow Rate	51
5.4	Low Pressure Calibration	56
5.5	Stability Verification	56
5.6	Transient Response	56
5.7	Airmotor Pump Evaluation	62
6	CONCLUSIONS	66
6.1	Performance Requirements	66
6.1.1	Flow Range and Accuracy	66
6.1.2	Transient Response	66
6.2	Design Objectives	67
6.2.1	Mechanical	67
6.2.2	Electronic	69

FIGURES

		<u>Page</u>
Figure	1. Circulation Diagram	2
	2. Electronic Controller Block Diagram	5
	3. Logic Diagram	8
	4. Pump Discharge Characteristics	13
	5. Lateral Injection Diagram	15
	6. Axial Injection Diagram	15
	7. Calculated Recirculation	23
	8. Injection/Recovery Evaluation Fixture	25
	9. Injection/Recovery as Incorporated	25
	10. Photograph, WRFF	27
	11. WRFF Assembly 108912	29
	12. Photograph, Conditioner Front Panel	32
	13. Photograph, Conditioner Rear Panel	33
	14. Assembly, Signal Conditioner 108936	34
	15. WRFF Uncertainty Analysis	41
	16. System Calibration Curve	52
	17. Composite Calibration Curve	53
	18. Mainstream Meter Calibration Curve	54
	19. Recirculation Flow Rate (Curve)	55
	20. Low Pressure Calibration Curve	57
	21. Stability Calibration Curve No. 1	58
	22. Stability Calibration Curve No. 2	59
	23. Transient Response, Bench Test	63
	24. Transient Response, System Test	64
	25. Airmotor System Calibration Curve	65

TABLES

		<u>Page</u>
Table	1. Calculation Summary, Lateral Injection	20
	2. Sample Calculation, Axial Injection	21
	3. Calculation Summary, Axial Injection	22
	4. Flowmeter Repeatability Uncertainty	39
	5. Zero Error Analysis	40
	6. Summary of Tests Performed	50

APPENDICES

APPENDIX A
TEST PROCEDURE

		<u>Page</u>
Paragraph	1. System Purge & Zero	72
	1.1 System Purge	72
	1.2 WRFF Zero	72
	2. WRFF Calibration	72
	3. WRFF Low Pressure Calibration	72
	4. Stability Verification	73
	5. Mainstream Meter Calibration	73
	6. Transient Response	74
	7. Airmotor Pump Evaluation	74
	Calibration Data Sheet No. 1	75
	Calibration Data Sheet No. 2	76
	Calibration Data Sheet No. 3	77
	Calculation Sheet - % Deviation	78
	Test Equipment List	79
	System Set Up, Seraphin Flask	80
	System Set Up, Prover Calibration	81
	Calibration Curve Blank	82

APPENDIX B
TEST DATA AND CALCULATIONS

		<u>Page</u>
Figure	B.1. Mainstream Meter Calibration	84
	B.2. System Calibration	88
	B.3. Low Pressure Calibration	93
	B.4. Stability Calibration No. 1	98
	B.5. Stability Calibration No. 2	103
	B.6. Airmotor System Calibration	108

1 INTRODUCTION

1.1 Background

In the testing of jet engines, fuel flow rates must be measured accurately over a wide range of flows, from idle to takeoff, which may be in the ratio of 140 to 1 or greater. Further, studies of engine performance during acceleration require that the flow meter have excellent transient response, the acceleration time being on the order of a few seconds. Turbine meters are ideal for measuring flow transients, their response having been shown to be on the order of a few milliseconds. However, limitations of rangeability (in the order of 10 or 12 to 1) have in the past demanded that two or even three meters be successively switched into the stream in order to cover the full range of flow rates, with the result that the time required for switching results in a loss of data during critical intervals and additional signal conditioning is required to accommodate differing calibration factors.

A Phase I Program, Contract F40600-84-C0007, was completed on April 26, 1985. This program proved the feasibility of the recirculation method of wide range flow measurement over a 140 to 1 or greater range with a 1.0 percent or better measurement uncertainty.

A working prototype unit was delivered under this contract.

1.2 Theory of operation, recirculation method

1.2.1 Wide Range Fuel Flowmeter.

The Wide Range Flow Meter provides linear measurement of flow rate over a much wider range than can be normally achieved by conventional flow metering methods. Flow meters normally perform in a linear manner only over a limited range of flow rates, approximately 10 to 1 in the case of turbine flow meters. At rates lower than the useable range, output is not linear and often not

repeatable. In the Wide Range Flow Meter the nonlinear region is offset by recirculating a stream in an additive direction through the meter at a rate roughly equal to the minimum linear flow rate, thus allowing the meter to operate entirely within its linear range. Net flow rate is determined by measuring the flow rate in the recirculating stream and subtracting this value from the value measured by the main stream meter.

Referring to Figure 1:

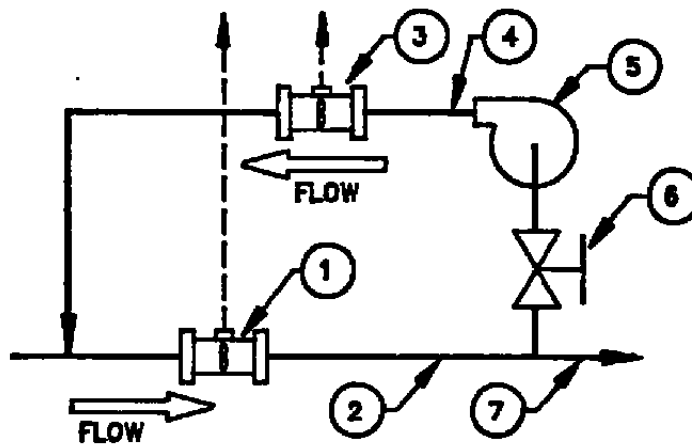

FIGURE 1. CIRCULATION DIAGRAM

The main stream turbine meter, 1, is mounted in the main stream 2. Recirculating stream 4, connects downstream from the main meter and reconnects on the upstream side. Pump 5, circulates fluid through the recirculating meter, 3, at a roughly constant rate of flow. Shut off valve, 6, provides for operation of the mainstream meter only, without recirculation.

The two meters are readily calibrated against one another by shutting off the main stream with only the recirculating stream operating. The two meters are then operating at identical flow rates, and the subtracted pulse output is set to zero by automatic setting of a digital rate multiplier in the computing circuit. By so doing, errors are eliminated which would result from variations in the calibration factor of either meter, particularly when the main stream flow rate is near zero. Such variations become less significant as the flow rate increases, and are negligible at the higher rates.

It should be observed that the system calibration factor is the same with and without recirculating flow.

With Pump 5 turned off and shut-off valve 6 closed, flow through the mainstream meter at location 2 is identical to system flow 7. Under these conditions the systems electronic signal conditioner is subtracting the output of meter 3, which is zero, resulting in a system calibration factor identical to that achieved with recirculating flow.

1.2.2 Signal Conditioner.

The signal conditioner scales outputs from the two meters to equal units and then subtracts the recirculating meter output to produce a final output representing the main stream flow rate.

Referring to Figure 2, Electronic Controller block diagram, pulse stream A is from the main stream flow meter and pulse stream B is from the recirculation flow meter.

The first stage is an operational amplifier with AC feedback to stabilize the output amplitude as the meter pulse frequency increases with flow rate.

The first stage output is the input to a zero crossover detector, having an output frequency double that of its input.

The A and B pulse streams are synchronized to an internal 100KHz clock which prevents any time coincidence between the two streams.

The 4 digit scaler multiplies pulse stream B by a factor to produce a pulse stream B2 which is the same frequency as that from the main stream flowmeter A when the main stream is shut off and the recirculating stream is flowing. The B pulse stream is then subtracted from the A pulse stream to produce zero frequency output at zero main stream flow.

The subtracter Network consists of one four stage binary up/down counter with appropriate control logic.

Any accepted B2 pulse will cause the counter to count up one pulse and any accepted A0 pulse will cause the counter to count down one pulse.

Part of the control logic senses if there is any count in the counter. If there is, the first A0 pulse that follows any B2 pulse will be inhibited from the A-B output. However, this same A0 pulse will down count the counter one pulse. If, at this time, the counter is zero and another A0 pulse occurs before another B2 pulse, this A0 pulse is output as an A-B pulse. If a B2 pulse occurs before another A0 pulse, the counter will be counted up one count and the following A0 pulse will be inhibited from the A-B output.

Due to "on line" variations of the pulse frequency from the A and B pulse streams, it is possible to accumulate some extra B2 pulses. Up to sixteen of these extra B2 pulses can be accumulated without reducing the performance of the subtracter. These extra B2 pulses would be accumulated if the frequency of the A0 pulse stream falls below that frequency of initial calibration.

REVISIONS			
REV	DESCRIPTION	DATE	BY
A	REDESIGNED SUBTRACTOR	10-10-87	JAH
B	PROGRAM FOR PRESENT DESIGN	2-15-88	JAH
C	TYPD CORRECTION	3-12-88	JAH

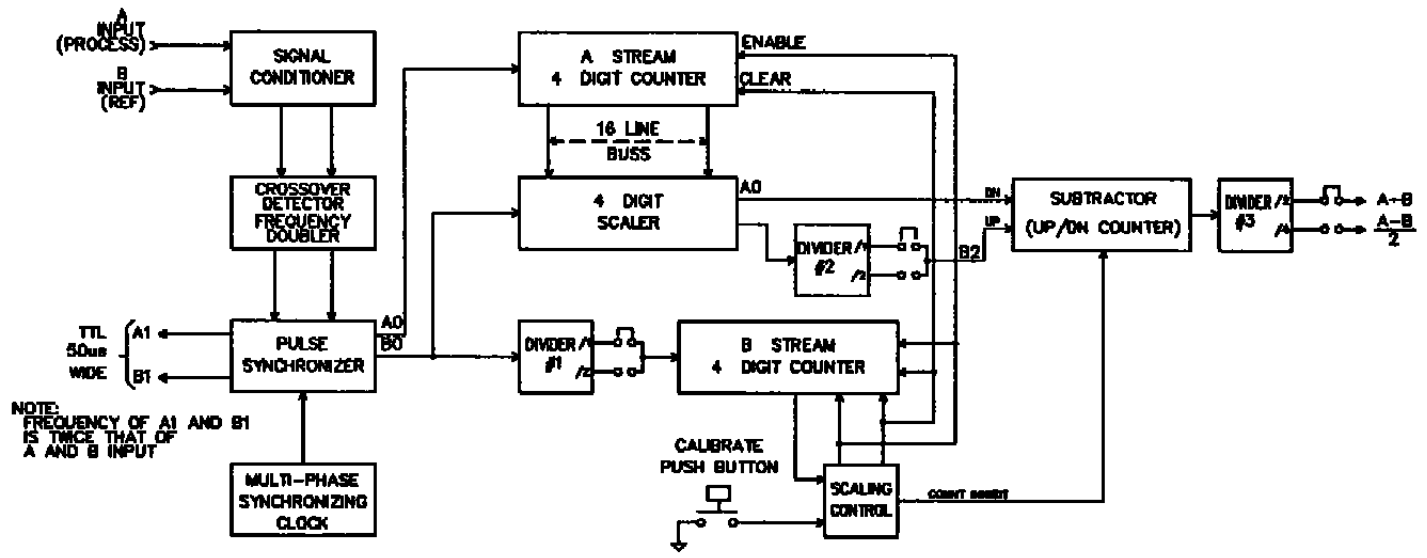

NOTE:
FREQUENCY OF A1 AND B1
IS TWICE THAT OF
A AND B INPUT

FIGURE 2. ELECTRONIC CONTROLLER BLOCK DIAGRAM

WAUGH CONTROLS CORPORATION
 5001 FULLERTON AVENUE - QUATERTOWN
 CALIFORNIA 91711 - (916) 866-8221

**BLOCK DIAGRAM
 ELECTRONIC CONTROLLER -
 WIDE RANGE FLOW METER**

REV: 1
 DATE: 1-1-88
 BY: JAH
 DATE: 1-1-88
 BY: JAH

REV: C
 DATE: 3-12-88
 BY: JAH

C112820-01

SCALE: NONE (SEE) SHEET 1 OF 1

A second part of the control logic senses when the counter is full and, at this time, will inhibit any further count of B2 pulses. This is to prevent a counter roll-over to zero, which would allow an unwanted A0 pulse to be passed to the A-B output.

A two to one change in scaler resolution has been provided. However, the increased resolution can be implemented only if the input A and B pulse stream ratio is less than 0.5 (A/B).

If the ratio is less than 0.5, divider #1 is set in the divide by two position. This allows the A stream counter to count twice as many pulses as compared to the divide by one character. However, the B2 output would have twice as many B2 pulses as actually needed for proper subtraction. Therefore, divider #2 must also be set in the divide by two position. This second division of two also tends to even the pulse to pulse period of the A-B output for better performance of any pulse to DC converter driven by the A-B output.

The divider #3 provides an additional divide by two for the A-B output. This will further even the pulse to pulse period of the A-B output for smoother pulse to DC converter performance. However, the DC converter must be scaled up by a factor of two for correct readings.

After calibration, as product is allowed to flow, A-B pulse stream will reflect the actual product flow. See Figure 3 for the system logic diagram.

Automatic Scaling is performed as follows:

1. The main stream is shut off.

2. The scaling control push button PB is pressed, clearing A and B stream counters of all counts. When PB is released, both counters are enabled and start counting their respective pulse streams. The B stream counter accumulates 10,000 B stream pulses. When this count has been reached, the scaling control disables the pulse input of both counters.
3. The count in the A stream counter controls the multiplication factor that is applied to the B pulse stream so that B2 pulse stream frequency is equal to A0 pulse stream.
4. A0 and B2 pulse streams are then fed into the subtracter network and A-B pulse stream is now zero.

REVISED			
LR	DESCRIPTION	DATE	APPROVED

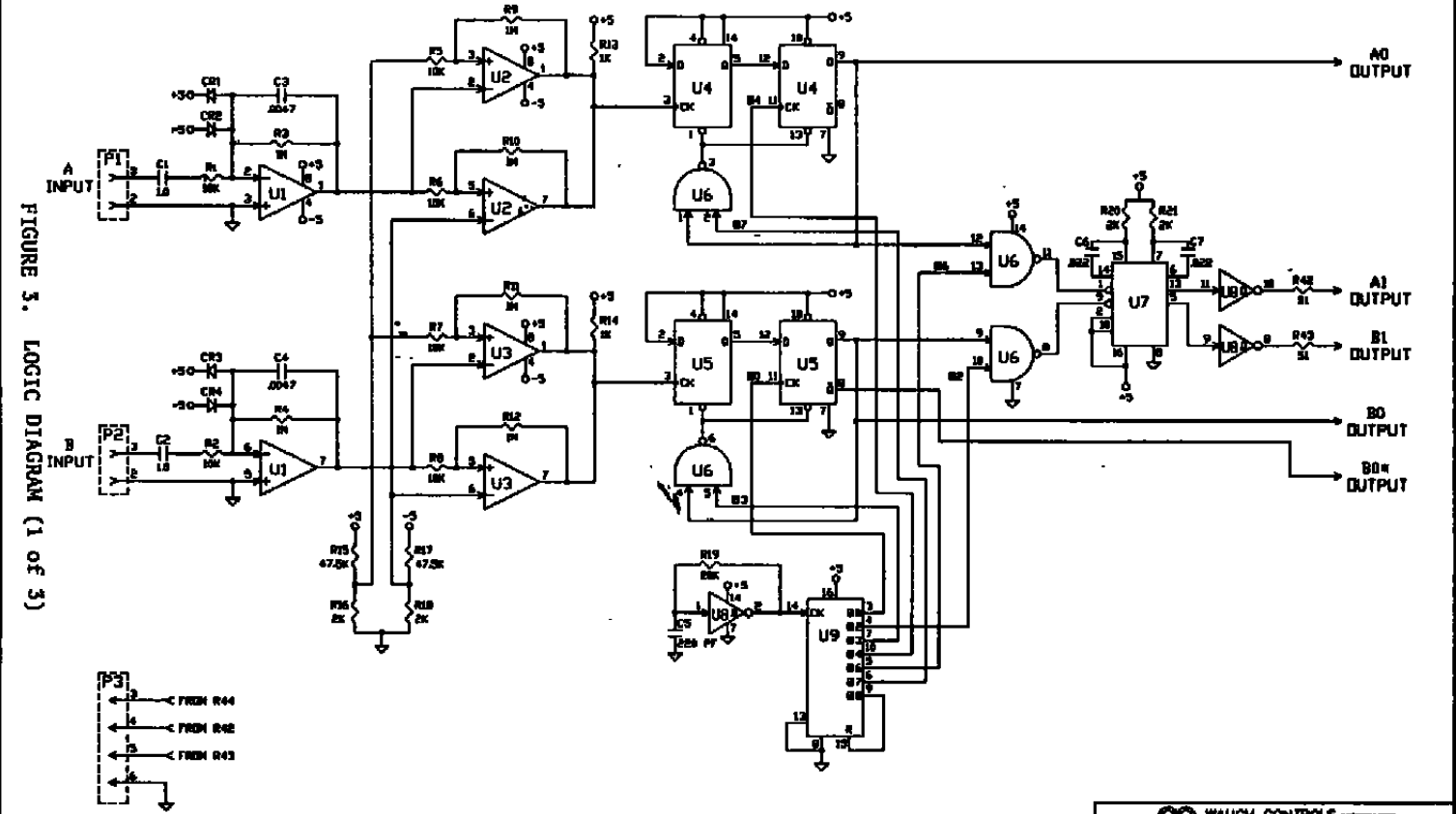
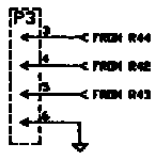
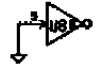



FIGURE 5. LOGIC DIAGRAM (1 OF 3)

- U5...74HC017
- U6...74HC14
- U7...74HC238
- U8...74HC14
- U9...74HC139
- U1...74HC017
- U2...74HC017
- U3...74HC017
- U4...74HC017
- U5...74HC017
- U6...74HC017
- U6...74HC017
- U7...74HC138
- U8...74HC14
- U9...74HC139

NOTES: CAPACITORS IN MFD - 33V OR GREATER
ALL RESISTORS ARE OHMIC SERIES
UNLESS OTHERWISE NOTED



WAUGH CONTROLS CORPORATION
 6000 FALLBROOK AVENUE - QUATERSITE
 CALIFORNIA 92521 - (800) 728-1281

LOGIC DIAGRAM
WIDE RANGE FLOW METER

C112820-02

SCALE NONE OTHER

DR	J. HIRNER	DATE	
CHK		BY	
APPD		DATE	
APPV		DATE	

REVISION		
NO	DESCRIPTION	DATE

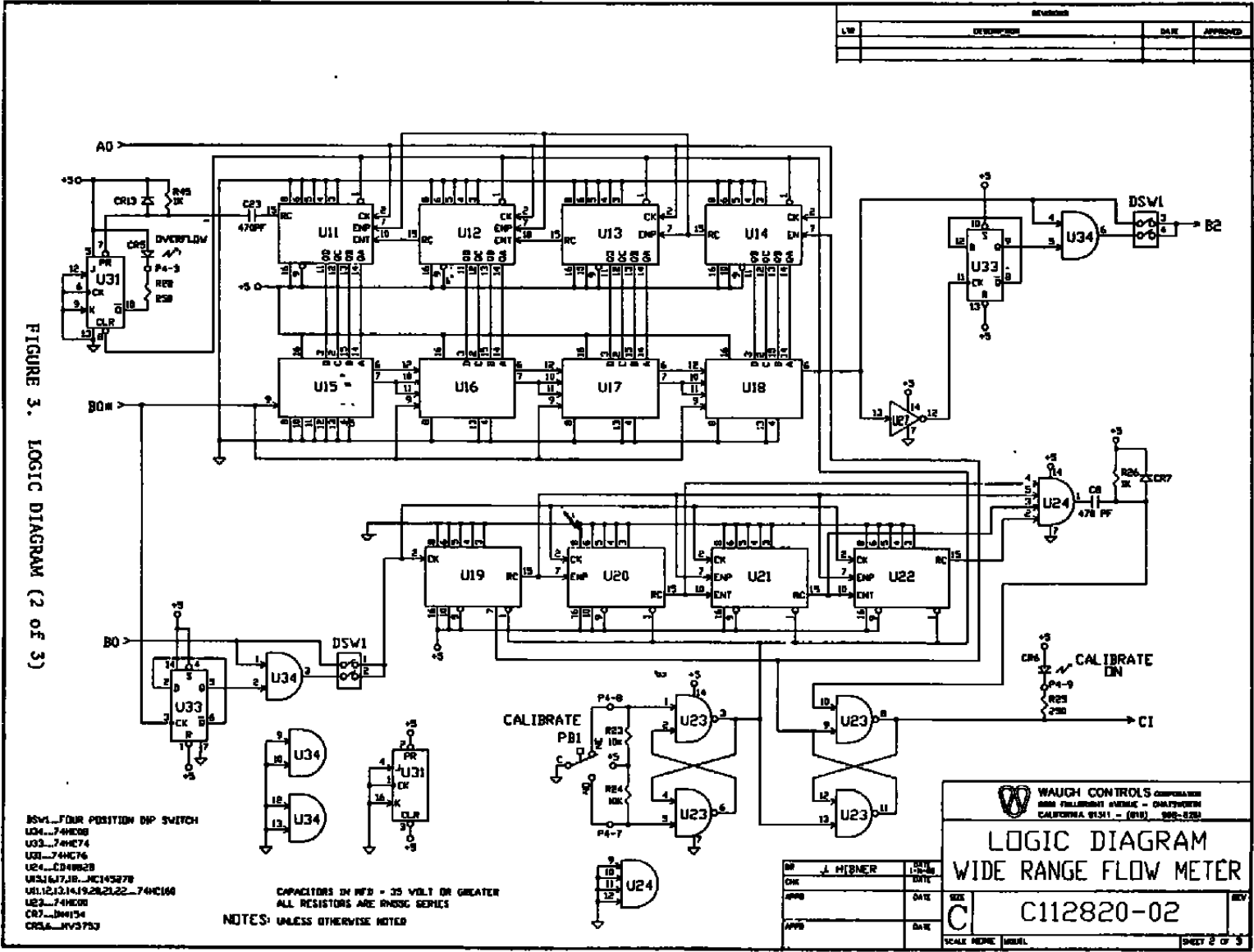



FIGURE 3. LOGIC DIAGRAM (2 OF 3)

- DSW1...FOUR POSITION DP SWITCH
- U04...74HC08
- U03...74HC74
- U02...74HC76
- U04...CD4062B
- U05, U17, U18...MC145277
- U11, U12, U13, U14, U19, U20, U21, U22...74HC164
- U23...74HC00
- CR7...D44134
- CR13...MV3753

NOTES: CAPACITORS IN MFD - 35 VOLT OR GREATER
ALL RESISTORS ARE RNS32 SERIES
UNLESS OTHERWISE NOTED

WAUGH CONTROLS CORPORATION
 8000 TULLOCH AVENUE - OAKTOWN
 CALIFORNIA 91341 - (818) 959-5200

LOGIC DIAGRAM
WIDE RANGE FLOW METER

DESIGNED BY: J. HIBNER
 DATE:
 APPR:
 DATE:
 REV: **C**
 SCALE: NONE UNITS:
 SHEET 2 OF 3

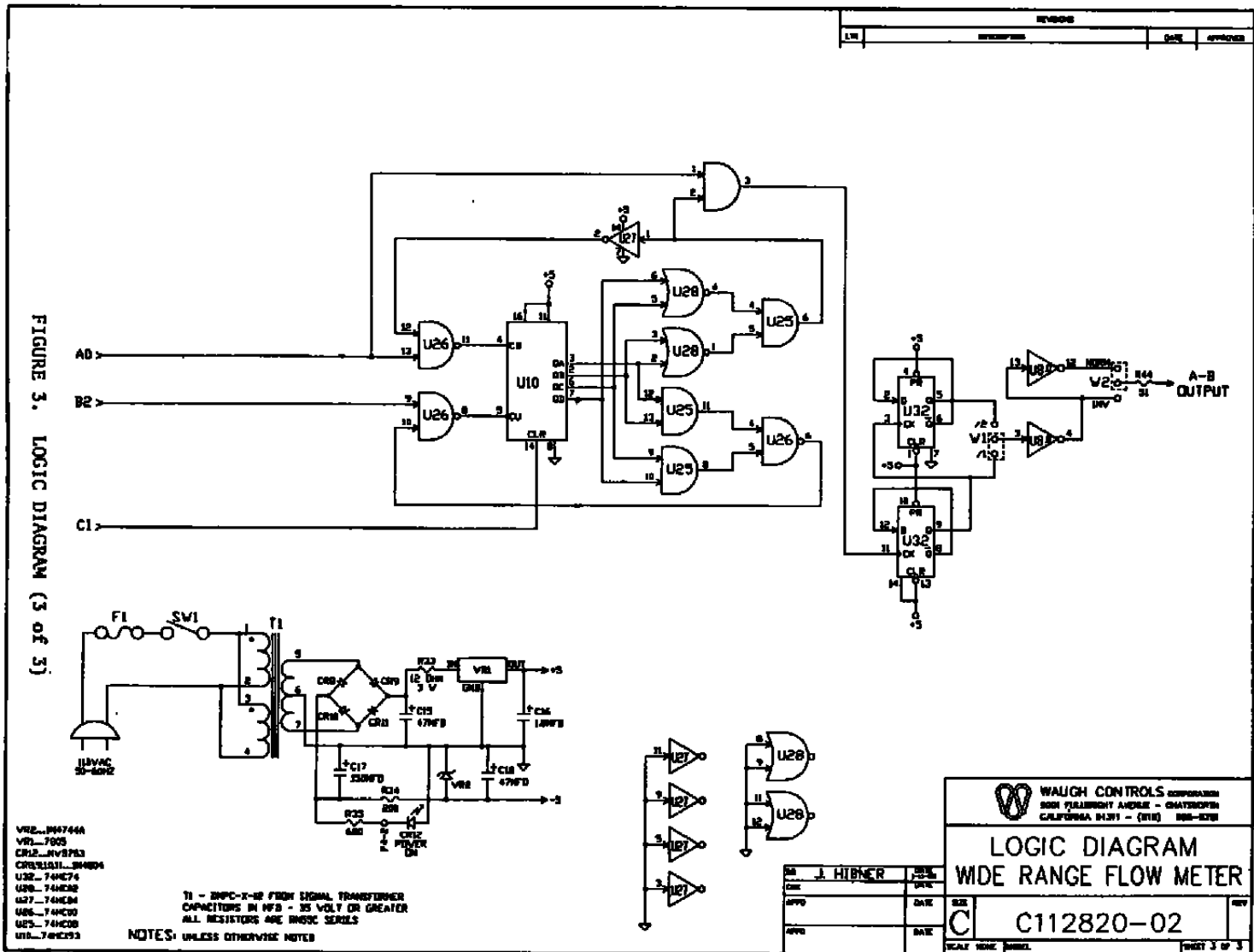

FIGURE 3. LOGIC DIAGRAM (3 of 3)

- VRE...M9744A
- VR1...7005
- CR12...MVB753
- CR13...MVB753
- CR14...MVB753
- CR15...MVB753
- CR16...MVB753
- CR17...MVB753
- CR18...MVB753
- CR19...MVB753
- CR20...MVB753
- CR21...MVB753
- CR22...MVB753
- CR23...MVB753
- CR24...MVB753
- CR25...MVB753
- CR26...MVB753
- CR27...MVB753
- CR28...MVB753
- CR29...MVB753
- CR30...MVB753
- CR31...MVB753
- CR32...MVB753
- CR33...MVB753
- CR34...MVB753
- CR35...MVB753
- CR36...MVB753
- CR37...MVB753
- CR38...MVB753
- CR39...MVB753
- CR40...MVB753
- CR41...MVB753
- CR42...MVB753
- CR43...MVB753
- CR44...MVB753
- CR45...MVB753
- CR46...MVB753
- CR47...MVB753
- CR48...MVB753
- CR49...MVB753
- CR50...MVB753
- CR51...MVB753
- CR52...MVB753
- CR53...MVB753
- CR54...MVB753
- CR55...MVB753
- CR56...MVB753
- CR57...MVB753
- CR58...MVB753
- CR59...MVB753
- CR60...MVB753
- CR61...MVB753
- CR62...MVB753
- CR63...MVB753
- CR64...MVB753
- CR65...MVB753
- CR66...MVB753
- CR67...MVB753
- CR68...MVB753
- CR69...MVB753
- CR70...MVB753
- CR71...MVB753
- CR72...MVB753
- CR73...MVB753
- CR74...MVB753
- CR75...MVB753
- CR76...MVB753
- CR77...MVB753
- CR78...MVB753
- CR79...MVB753
- CR80...MVB753
- CR81...MVB753
- CR82...MVB753
- CR83...MVB753
- CR84...MVB753
- CR85...MVB753
- CR86...MVB753
- CR87...MVB753
- CR88...MVB753
- CR89...MVB753
- CR90...MVB753
- CR91...MVB753
- CR92...MVB753
- CR93...MVB753
- CR94...MVB753
- CR95...MVB753
- CR96...MVB753
- CR97...MVB753
- CR98...MVB753
- CR99...MVB753
- CR100...MVB753

T1 - 2WPC-X-52 FERRITE SIGNAL TRANSFORMER
 CAPACITORS IN MFD - 35 VOLT OR GREATER
 ALL RESISTORS ARE 1/4W 5% SERIES

NOTES: UNLESS OTHERWISE NOTED

WALSH CONTROLS CORPORATION
 3034 PLUMBING AVENUE - CHATSWORTH
 CALIFORNIA 91311 - (818) 888-8278

LOGIC DIAGRAM
 WIDE RANGE FLOW METER

DESIGNED BY	J. HIBNER	REV.	
CHECKED BY		DATE	
APPROVED BY		DATE	
SCALE	1:1	REV.	
C112820-02		PAGE 3 OF 3	

2 OBJECTIVES

The primary objective of the program was to provide a Wide Range Fuel Flowmeter (WRFF) capable of measuring the flow of jet fuel over a 140 to 1 or greater range with a 1.0 percent or better measurement uncertainty and a transient response of 0.5 seconds or less.

The specified flow range of 500 to 70,000 pounds per hour, equates (using the density of JP-4 at 60 Deg. F) to a flow rate of 1.31 to 183 gallons per minute.

Additional objectives resulting from evaluation of the prototype WRFF created during Phase I were:

Repackage the meter to be as small and economically producible as practical.

Replace the recirculating pump with a smaller more reliable unit compatible with jet fuels.

Investigate further the availability of a suitable metering pump to replace the recirculation flow meter.

Provide means to disable the recirculating flow when not operating in the low flow range.

Repackaged the electronic conditioner smaller and suitable for rack or panel mounting.

Provide direct pulse outputs for both of the turbine meters.

Investigate the performance of an air-driven pump for possible use in hazardous environments.

3 PROCEDURES

3.1 Pump Selection.

Since the pump is the largest component of the WRF and would largely dictate the configuration of the final system, selection of a pump was the first item addressed.

It was perceived that if a positive displacement pump could be obtained with essentially constant flow characteristics over the range of pressure drops anticipated, it would be possible to eliminate the one inch recirculation flow meter. In order for a positive displacement pump to be viable, it would have to be competitive size and price wise with the centrifugal pump-flowmeter combination.

It should be noted that some reservations as to reliability existed (at least in regard to plunger type positive displacement pumps) as a plunger pump had been evaluated during phase I and had seized during early testing.

Manufacturers of plunger, vane, and gear type positive displacement and centrifugal pumps were contacted.

Some of the positive displacement pump manufacturers contacted expressed reservations about reliability in this application, and the units ranged from 28 to 48 inches long, weighed in the neighborhood of 200 pounds and cost from \$2,100 to \$2,900.

In view of the requirements for size reduction, reliability and to produce an economically viable product, a centrifugal pump became the obvious choice.

A Price Model SC100-25 Centrifugal Pump was selected as being appropriate for the application. This unit has a 316 stainless steel head and impeller, and an explosion proof motor.

The pump discharge characteristics are presented in Figure 4, replotted from the manufacturer's literature for clarity, and to present pressure in PSI rather than head in feet.

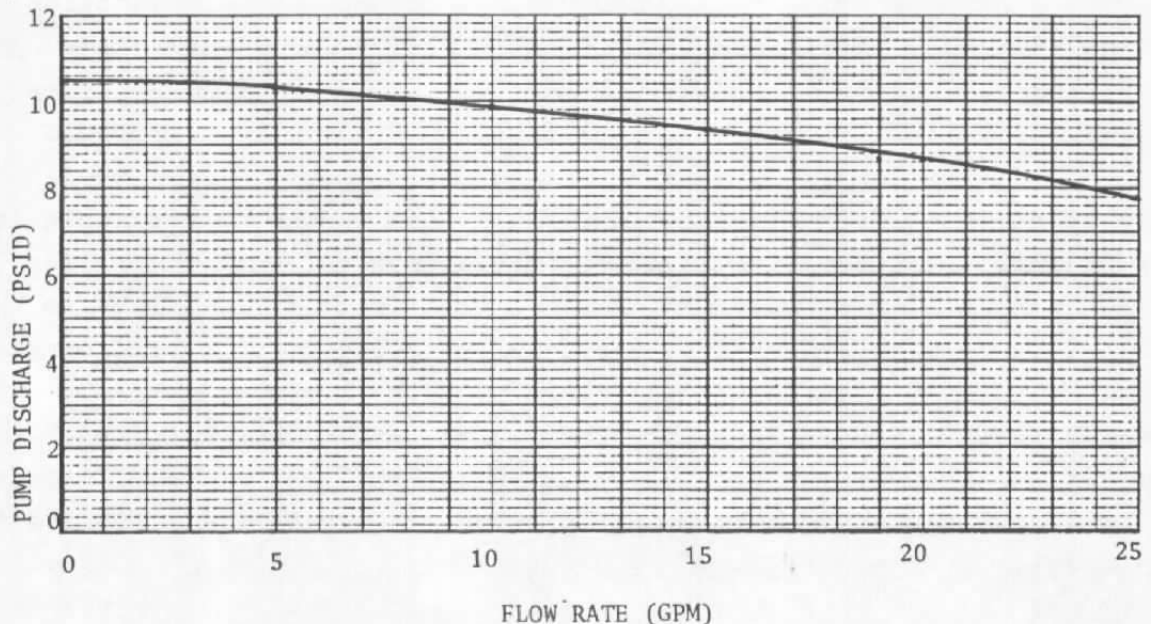

FIGURE 4. PRICE PUMP DISCHARGE CHARACTERISTICS

The unit was also available with a Gast Air Motor drive with identical mounting provisions providing interchangeability during our testing.

- 3.2 Recirculation Injection and Recovery

During the pump investigation phase of the program it was recognized that by injecting the recirculating flow in a downstream facing tube and recovering the fluid in an upstream facing tube the velocity pressure of the mainstream flow could be utilized to cancel the mainstream pressure drop between the injection and recovery points.

Since the only variable in the recirculation loop is the line loss in the mainstream flow with varying flow rates, this approach would, if successful, result in a constant head across the pump and essentially constant recirculation flow.

This is very desirable as it essentially eliminates any non linearity present in the one inch recirculation meter as a source of system error.

In addition, elimination of high back pressures on the recirculating pump permit the use of a smaller, more economical unit.

Prior to fabrication of test hardware, a series of calculations were performed to determine the magnitude of back pressures seen by the recirculation pump with introduction and recovery of the recirculation flow at right angles to the mainstream flow as incorporated in the phase 1 unit, and utilizing the inwardly facing tubes under consideration.

See Figures 5 and 6 for clarification of terms used in the following discussion.

Three factors influence the variable pressure drop ($P_1 - P_2$) seen by the recirculation system as mainstream (Q_2) flow rate is varied.

The primary loss is the pressure drop across the mainstream turbine meter and associated plumbing between the introduction and retrieval points. This pressure drop ($P_3 - P_4$) is a function of the square of the flow rate in the metering section (Q_m) which is the combined flows (Q_2) and the recirculation flow (Q_1). This is the loss which we desire to eliminate or greatly reduce as it is virtually zero at low flow rates but becomes significant at higher flow rates resulting in lower recirculation flow, possible recirculation flow meter non linearity, and operation of the recirculation meter at a less desirable operating point.

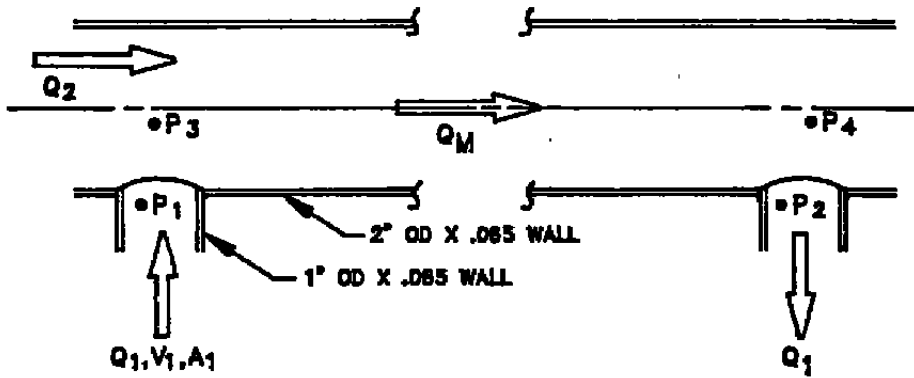

FIGURE 5. LATERAL INJECTION

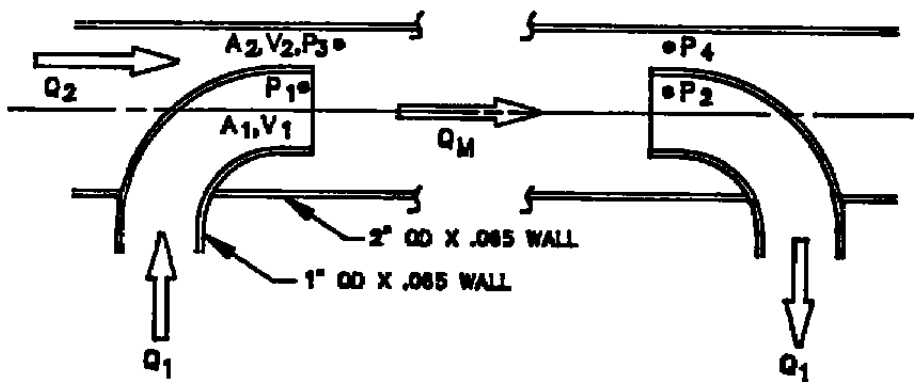

FIGURE 6. AXIAL INJECTION

The second variable to be considered is the expansion and contraction losses incurred at the point of injection and recovery respectively.

In the case of lateral injection and recovery, (Figure 5), the two streams (Q_1 & Q_2) are at right angles, the injection loss is unaffected by the mainstream velocity and the losses are proportional to the velocity pressure of the one inch stream (P_{v1}), and are therefore proportional to Q_1^2 .

For axial injection, (Figure 6), these losses behave quite differently. For $Q_2 = 0$, the losses will be similar for axial and lateral injection. As Q_2 increases the relative velocity ($V_r = V_1 - V_2$) decreases until a point is reached where $V_2 = V_1$, the streams merge smoothly, and the expansion and contraction losses become zero.

In the geometry chosen, this condition occurs at a mainstream flow rate (Q_2) of 79.2 GPM.

As the mainstream flow rate increases further, V_2 increasingly exceeds V_1 creating a negative relative velocity which impacts the downstream recovery tube creating a positive pressure at P_2 and has an aspirating effect on the upstream injection tube creating a negative pressure at P_1 .

The third loss contributing to the recirculation pump back pressure is the loss within the one inch recirculation loop incorporating the one inch flowmeter and associated plumbing. The loss incurred in this segment will be a function of the square of the velocity (or flow rate) in this line $\Delta P_1 = K(Q_1)^2$.

The sum of the above losses represent the head requirement of the recirculating pump, and in conjunction with the pump discharge characteristics determine the recirculation flow rate.

Example of calculation (Lateral injection/recovery)Assumed

$$\begin{aligned}(P3 - P4) &= 6.0 \text{ PSI @ } Q2 = 200 \text{ GPM} \\ Q1 &= 24.0 \text{ GPM @ } Q2 = 0 \\ \zeta &= 62.34 \#/\text{ft}^3 \text{ (water at 60 deg. F)}\end{aligned}$$

Units

$$\begin{aligned}V \text{ (velocity)} &= \text{FT/sec} \\ Q \text{ (flow rate)} &= \text{GPM} \\ A \text{ (area)} &= \text{in}^2\end{aligned}$$

Pertinent Dimensions

Recirculation tubing is 1.00 OD X .065 wall

$$\begin{aligned}d_i &= .87 \text{ in} \\ A_1 &= .7854 (.87)^2 = .594 \text{ in}^2\end{aligned}$$

Mainstream tubing is 2.00 OD X .065 wall

$$\begin{aligned}d_i &= 1.87 \text{ in} \\ A_2 &= .7854 (1.87)^2 - .7854 (1.00)^2 = 1.961 \text{ in}^2\end{aligned}$$

Equations

$$P_v = \frac{\zeta V^2}{2G(144)} = \frac{62.34 V^2}{(2)(32.2)(144)} = .0067 V^2$$

$$V = \frac{Q}{A} = \frac{\text{GAL}}{\text{min in}^2} \cdot \frac{\text{FT}^3}{7.48 \text{ gal}} \cdot \frac{\text{min}}{60 \text{ sec}} \cdot \frac{144 \text{ in}^2}{\text{FT}^2} = \frac{Q(.3208)}{A}$$

As previously cited, the back pressure (HEAD) seen by the pump (ΔP_p) is a function of three cumulative losses:

For the calculation of P3 - P4 the flow rate through the metering section, QM is considered to be the mainstream flow rate Q2 plus a constant recirculation flow rate, Q1, of 24 GPM.

It should be observed that a minor error is introduced by not adjusting Q1 for variations in recirculating flow; however, it can be proven that in no case does this error exceed 0.1 PSI.

(P3 - P4) can be calculated for any flow rate as follows:

$$(P3 - P4) = \frac{(Q2 \text{ test} + 24)^2}{(200 + 24)^2} \times 6.0 \text{ PSI}$$

The expansion and contraction losses, $\Delta P \text{ exp}$, incurred in the lateral mode are equal to the combined resistance coefficient K multiplied by the velocity pressure, $Pv1$, in the one inch stream.

Reference: Crane Technical Paper No. 410 (A-26)

$$\frac{d1}{d2} = \frac{.87}{1.87} = .47$$

Resistance Coefficient (enlargement)	=	.62
	(contraction)	= <u>.35</u>
Combined Coefficient (K)	=	.97

Therefore:

$$\Delta P \text{ exp} = .97 Pv1 = \frac{(.97)(\rho)(V1)^2}{2g(144)}$$

Utilizing the relationship of V1 and Q1, and combining constants, this becomes:

$$\Delta P \text{ exp} = .0019 Q1^2$$

The third loss contributing to the recirculation pump back pressure is the loss within the one inch recirculation loop incorporating the one inch flow meter and associated plumbing. The loss incurred in this segment is a function of the square of the velocity (or flow rate) in this line.

$$\Delta P1 = K(Q1)^2$$

The constant for this segment can be determined from the no flow ($Q_2 = 0$) condition as follows:

$$\Delta P_p = (P_3 - P_4) + K(Q_1)^2 + \Delta P_{exp.}$$

Q_1 assumed to be 24.0 GPM

$$(P_3 - P_4) \text{ from earlier equation} = \frac{(24)^2 \times 6}{(224)^2} = .07 \text{ psi}$$

$$\Delta P_{exp} = .0019 Q_1^2 = 1.09 \text{ PSI}$$

$$\Delta P_p \text{ from Price pump curve (Figure 4)} = 8.00 \text{ PSI}$$

$$8.00 = K(24)^2 + .07 + 1.09$$

$$K = \frac{8.00 - .07 - 1.09}{24^2} = .0119$$

We can now use the following equation to calculate recirculation flow rate at various system flow rates.

$$\begin{aligned} \Delta P_p &= (P_3 - P_4) + .0119 Q_1^2 + .0019 Q_1^2 \\ &= (P_3 - P_4) + .0138 Q_1^2 \end{aligned}$$

While this equation cannot be solved directly, in conjunction with the pump discharge curve a unique solution is possible.

A value for Q_1 is selected and Q_1^2 and ΔP_p are calculated. Q_1 and ΔP_p are spotted on the pump curve. If necessary, a second value is chosen and by interpolation a specific flow rate is obtained.

An example of the calculation at $Q_2 = 25$ GPM is presented.

<u>Q1</u> <u>(GPM)</u>	<u>Q1²</u>	<u>(P3 - P4)</u> <u>(PSI)</u>	<u>.0138Q1²</u> <u>(PSI)</u>	<u>ΔPp</u> <u>(PSI)</u>
24	576	.29	7.95	8.24
23.5	552.25	.29	7.62	7.91

Interpolation yields a recirculation flow rate of 23.7 GPM at 8.02 PSI pump head.

Calculations were conducted over the flow range $Q_2 = 0$ to $Q_2 = 200$ GPM. Results are presented in Table 1 below, and plotted on Figure 7, page 23.

TABLE 1. CALCULATION SUMMARY, LATERAL INJECTION

<u>Q2</u> <u>(GPM)</u>	<u>Q1</u> <u>(GPM)</u>	<u>ΔP_p</u> <u>(PSI)</u>
0	24	8.00
25	23.7	8.02
50	23.3	8.10
75	22.6	8.25
100	21.7	8.40
125	20.7	8.60
150	19.3	8.80
175	17.4	9.05
200	15.4	9.30

Calculations (Axial injection/recovery)

The axial injection recirculation is calculated in a manner similar to above.

The mainstream metering loss ($P_3 - P_4$) is the same as for the lateral injection configuration explored above.

Similarly, the loss within the one inch recirculation loop is $.0119 Q_1^2$ as above.

TABLE 2. SAMPLE CALCULATION, AXIAL INJECTION

V2 < V1

$$\Delta P_p = (P3-P4) + .0119Q1^2 + \Delta P \text{ exp}$$

Q2 (GPM)	Q1 (GPM)	Q1 ²	(P3-P4) (PSI)	.0119Q1 ² (PSI)	V2 (FT/SEC)	V1 (FT/SEC)	Vr (FT/SEC)	Pvr (PSI)	$\Delta P \text{ exp.}$ (.97Pvr) (PSI)	ΔP_p (PSI)
25	24	576	.29	6.85	4.09	12.96	8.87	.53	.51	7.65
	24.5	600.25	.29	7.14	4.09	13.23	9.14	.56	.54	7.97
	24.3									7.90

21

Interpolation on the pump discharge curve yields a recirculation flow rate of 24.3 GPM at a head of 7.90 PSI

Q2 (GPM)	Q1 (GPM)	Q1 ²	(P3-P4) (PSI)	.0119Q1 ² (PSI)	V2 (FT/SEC)	V1 (FT/SEC)	Vr (FT/SEC)	Pvr (PSI)	2Pvr (PSI)	ΔP_p (PSI)
100	24	576	1.84	6.85	16.36	12.96	-3.40	-.08	-.16	8.53
	23	529	1.84	6.30	16.36	12.42	-3.94	-.10	-.21	7.93
	23.3									8.10

Interpolation yields 23.3 GPM recirculation flow rate at 8.10 PSI.

However, in this configuration the entrance losses (and at higher flow rates) the recovery obtained are not a function of $Q1^2$ alone, and so they cannot be combined with the recirculation loop losses.

Both functions are derived from the relative velocity pressure (Pvr) calculated from the relative velocity (Vr) which is $(V1-V2)$.

Again, the solution was achieved iteratively using the combined losses and the selected value of $Q1$ to obtain a fit on the pump discharge curve.

An example of the calculations conducted above and below the flow rate (79 GPM) where $Vr = 0$ are presented in Table 2.

Results of calculations from $Q2 = 0$ to $Q2 = 200$ GPM are presented in Table 3 and graphically in Figure 7.

TABLE 3. CALCULATION SUMMARY, AXIAL INJECTION

<u>Q2</u> <u>(GPM)</u>	<u>Q1</u> <u>(GPM)</u>	<u>ΔP_p</u> <u>(PSI)</u>
0	24.0	8.00
25	24.3	7.90
50	24.3	7.90
75	24.0	8.00
100	23.3	8.10
125	23.2	8.18
150	23.3	8.10
175	23.8	8.05
200	24.3	7.90

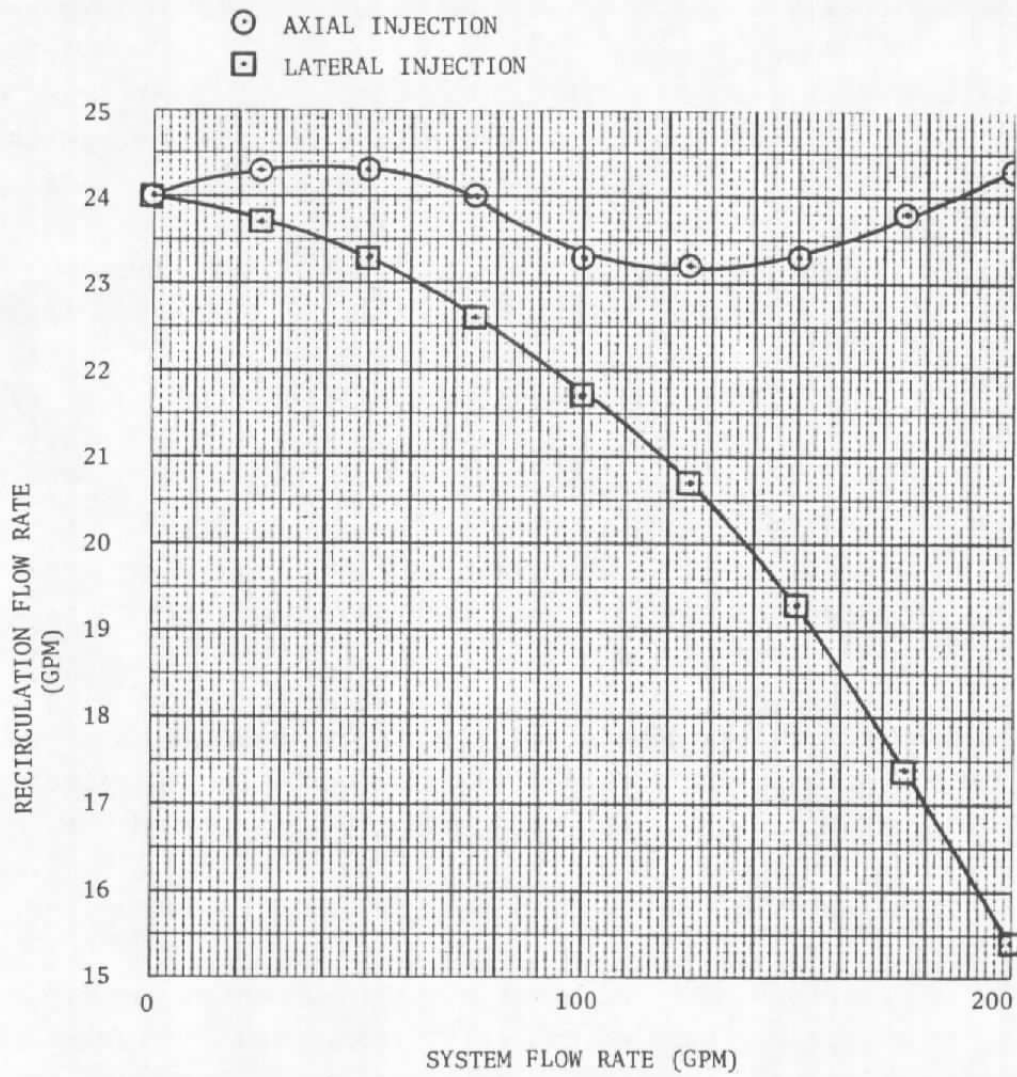

FIGURE 7. CALCULATED RECIRCULATION

A test fixture was created with inwardly facing tubes which were adjustable longitudinally into tapered sections, upstream and downstream of the mainstream flowmeter to verify the theory and to establish the correct area ratios of mainstream and recirculation flow. See Figure 8.

These tests indicated that a 1" OD X .065 Wall injection tube entering a 2" OD X .065 Wall mainstream tube provided very nearly optimum results.

This configuration was incorporated in the WRFF assembly. See Figure 9.

The theoretical benefits anticipated were confirmed during system calibration. See paragraph 5.3.1 and Figure 19, Page 55.

3.3 WRFF Meter Design.

A layout was created providing the smallest possible envelope. Component and assembly drawings were created, parts were fabricated, and the unit was assembled for test.

Considerable testing was conducted with poor results due to an incorrect and erratic scale factor being selected by the electronic conditioner. This was at the time wrongly attributed to swirl induced by the upstream fluid injection or variations in fluid profile at the inlet of the meter under varying flow conditions.

A series of tests conducted with various straightening sections in both the main stream, and recirculation loop, and perforated plate in the main stream to produce a consistent fluid profile to the mainstream meter did not produced satisfactory results.

It was finally determined that during the zero cycle, cavitation was occurring in the recirculating loop suction line.

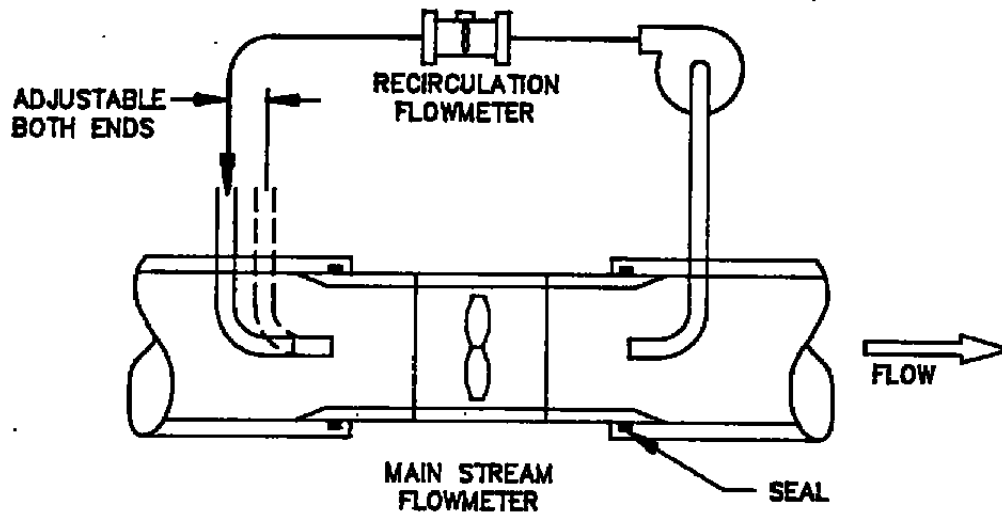

FIGURE 8. INJECTION/RECOVERY EVALUATION FIXTURE

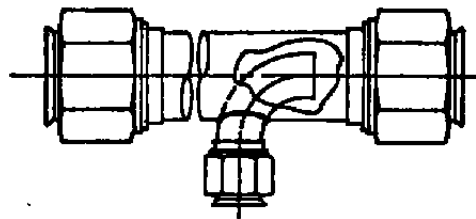

FIGURE 9. INJECTION/RECOVERY AS INCORPORATED

In this device even minor cavitation can be of serious consequence during the zero cycle since we are continuously circulating the fluid through both meters, and the relatively large outputs of the two meters are being subtracted to obtain zero.

This initial configuration had the recirculation meter and the circulation shut off valve in the pump suction line. This configuration had been chosen in an effort to create the smallest most desirable package.

New hardware was fabricated and the recirculation flowmeter was relocated downstream of the recirculation pump with some sacrifice in the overall size of the meter.

A photograph of the unit is presented as Figure 10.

As reconfigured, the unit produced repeatable data. The straightening added earlier was evaluated with the new configuration.

The optimum configuration proved to be with no straightening in either the mainstream or recirculating lines.

This is not surprising since the downstream facing injection tube provides symmetrical insertion of the recirculation flow and is reasonably upstream of the mainstream meter, and the recirculation meter is operating at very nearly constant flow conditions.

The advantage of removing the straightening is that the recirculation flow increased from approximately 20.5 GPM to 24.5 GPM providing a zero and low flow operation in a more desirable location on the flowmeter calibration curve.

27

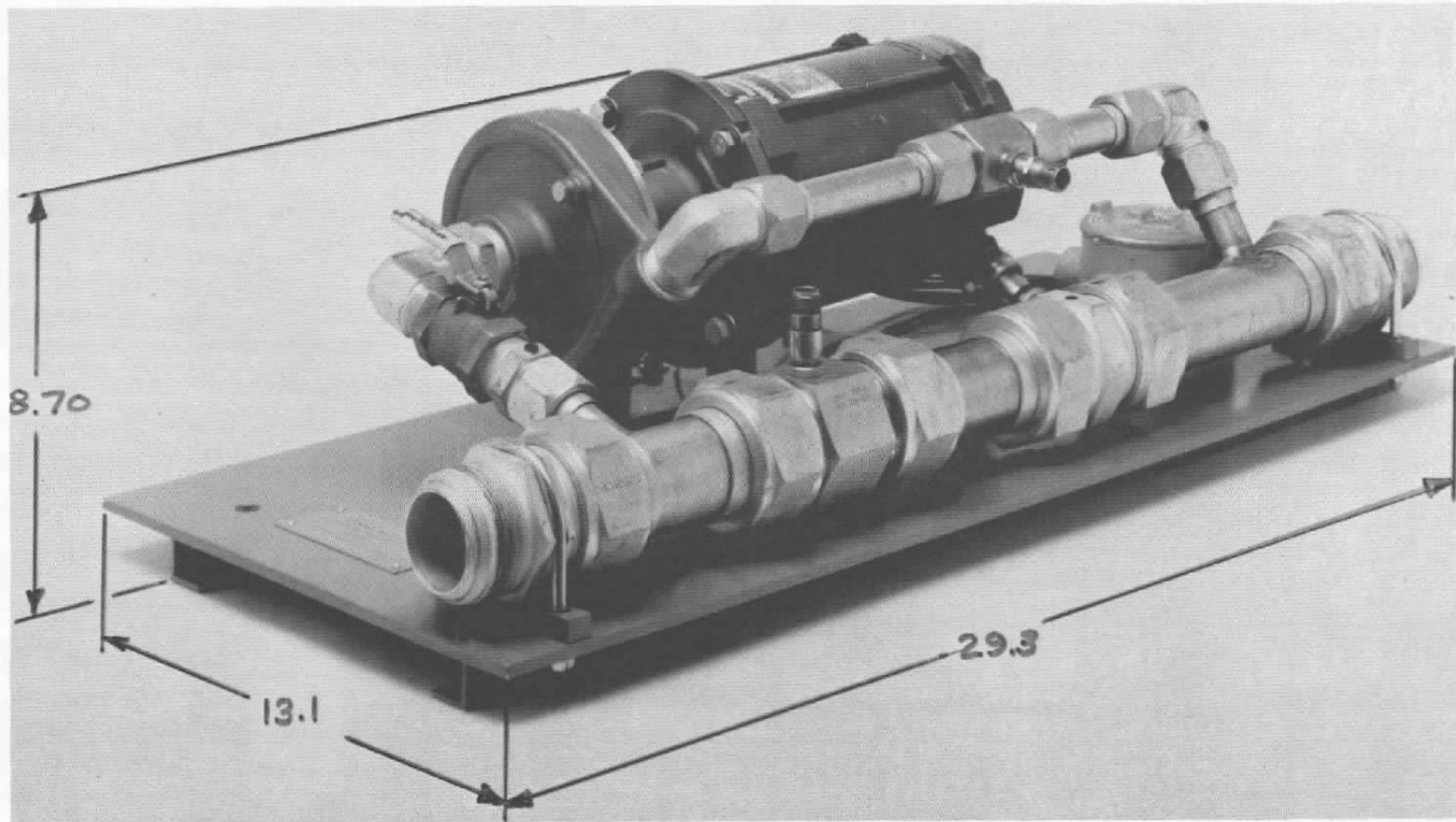

FIGURE 10. WRFF

The assembly drawing of the unit as delivered is presented as Figure 11.

The unit is 29.3 inches long, 13.1 inches deep, 8.7 inches high, and weighs 82 pounds.

For comparative purposes, the unit delivered under Phase I was 31 inches long, 28 inches deep, 19.5 inches high, and weighed 148 pounds.

Referring to Figure 11, it should be noted that the union, Item 32 was added during the reconfiguration of the system to permit utilization of the fabricated pitot assemblies, as a site for straighteners during our investigation and as a location for a pressure tap used during our test program. Subsequent units would be fabricated without this item, tube assembly Item 31, and two sets of nuts and sleeves, by elongating Item 14 to fit thus reducing cost and weight.

3.4 WRF Signal Conditioner Design.

The circuit design was created and a wire wrap prototype board was fabricated.

Initial testing was conducted utilizing signal generators to simulate the flowmeter input signals.

During early bench testing, the up/down counting technique being used to establish the system zero was found to be very time consuming.

The original scaling method was replaced with the 4 digit scaler and A and B stream counters indicated in Figure 2.

REVISIONS			
LTR	DESCRIPTION	DATE	APPROVED
A	REVISED TO AS BUILT	12-9-81	<i>[Signature]</i>
B	REVISED TO ADD COMPONENTS	2-16-87	<i>[Signature]</i>

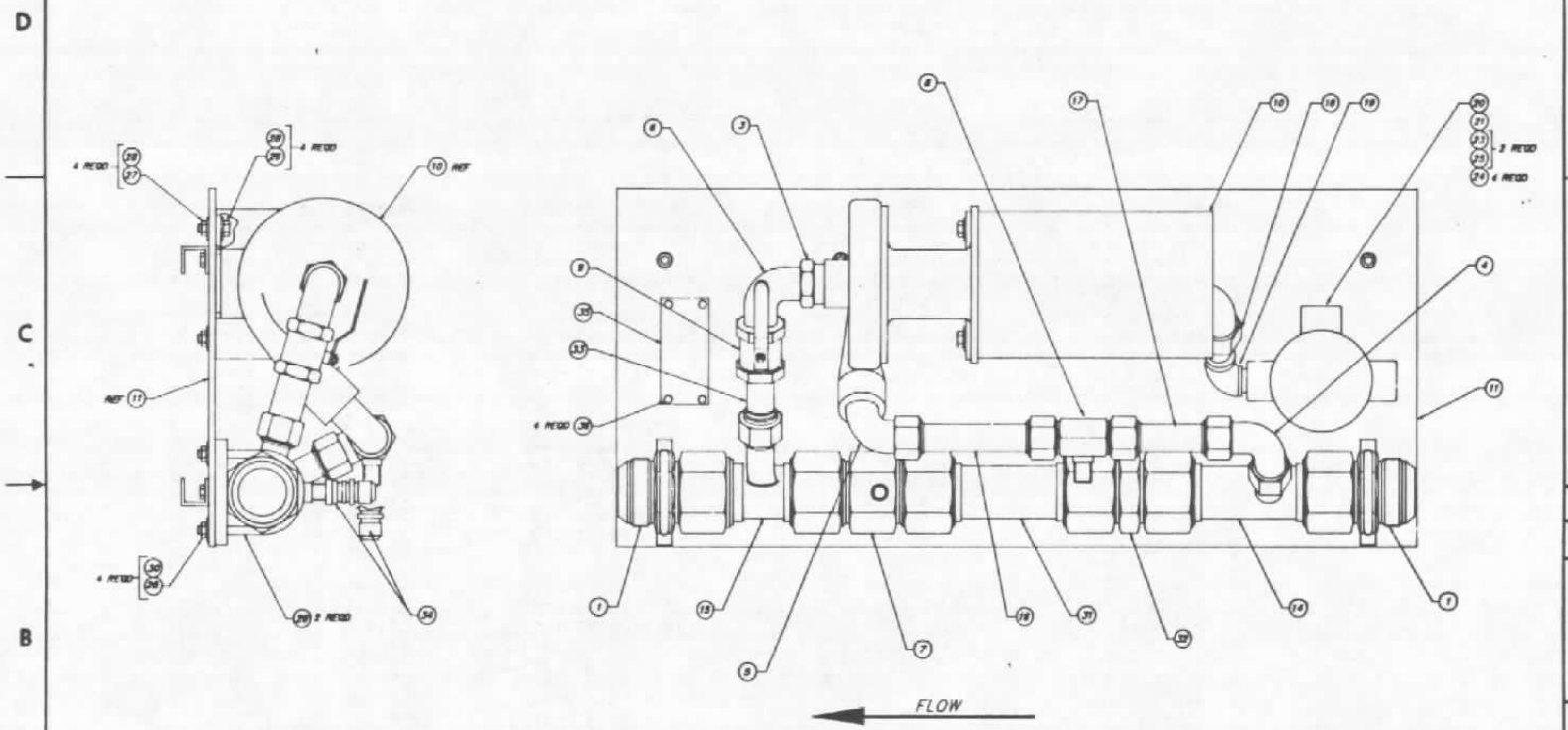

FIGURE 11. WRFF ASSY. (1 of 2)

NOTES: UNLESS OTHERWISE SPECIFIED
SEE AL108912 FOR LIST OF MATERIALS.

QTY REQD PER ASSY	CODE IDENT	PART OR IDENTIFYING NO.	NOMENCLATURE OR DESCRIPTION	REFERENCE DESIGNATION	ITEM NO.
			PARTS LIST		
	UNLESS OTHERWISE SPECIFIED DIMENSIONS ARE IN INCHES TOLERANCES		CONTRACT NO. F40600-BE-C0003 U.S. AIR FORCE AFDC		
	DECIMALS	ANGLES	 ASSEMBLY - WRFF		
	IN ± .015	MO ± .010			
	DO NOT SCALE DRAWING		APPROVED	DATE	
	MATERIAL		DR ECT H	9/17/8	
	FINISH		APPD	DATE	
	NEXT ASSY		APPD	DATE	
	USED ON		SIZE	CODE IDENT NO.	REV
	APPLICATION		C	108912	B
			SCALE	MODEL	BASIC
					SHEET OF

AEDC-TR-89-6

PRINT PHANTOM ITEMS
 PRINT COMPONENTS
 PRINT PHANTOM/COMPONENT COMMENTS

PARENT ITEM	CROSS REF ITEM	DESCRIPTION ASSY, WIDE RNG FUEL FLOWMTR MCC	BATCH QTY	ITEM TYPE	UNIT MEAS			
108912		ENGR DRAW	2/17/88		EA			
BOM ITEM	LL CD	COMPONENT & CROSS REF.	DESCRIPTION & COMMENT	ENGINEERING DRAWING NUMBER	QUANTITY PER	ITEM OPT	FIRST OP SEQ	LT ADJ
0001	01	108906	UNION, MODIFIED 2"	MCC	2.000	EA	2	
0003	01	238541	REDUCER, PIPE THREAD	PRK 1-1/4 X 1 PTR-S	1.000	EA	4	
0004	01	238542	ELBOW, UNION 1"	PRK 16-ETR-S	1.000	EA	4	
0005	01	238543	ELBOW, MALE 1"	PRK 16-CTX-S	1.000	EA	4	
0006	01	238544	ELBOW, PIPE MALE	PRK 1"-CR-S	1.000	EA	4	
0007	01	108919	724-2 TURBINE METER 2"	MCC	1.000	EA	2	
0008	01	108920	724-1 TURBINE METER 1"	MCC	1.000	EA	2	
0009	01	238545	VALVE	BBL B82-100	1.000	EA	4	
0010	01	238546	PUMP	PRC 5C100-25	1.000	EA	4	
0011	01	108905	ASSY, BASE PLATE	MCC	1.000	EA	1	
0014	01	108911-2	ASSY, PITOT	MCC	1.000	EA	1	
0015	01	108911-1	ASSY, PITOT	MCC	1.000	EA	1	
0016	01	108910-1	ASSY, TUBE 1"	MCC	1.000	EA	1	
0017	01	108910-2	ASSY, TUBE 1"	MCC	1.000	EA	1	
0018	05	238570	UNION, MALE 0.500	CEU UNY105	1.000	EA	4	
0019	01	238547	ELL, MALE 90°	CEU EL 195	1.000	EA	4	
0020	01	238548	CONDULET	ATN GRT 75	1.000	EA	4	
0021	06	238743	RELAY, SOLID STATE	MAG M6240 05R-1	1.000	EA	4	
0023	03	F51133	B-32X1.000 HS PAN PH SS		2.000	EA	4	
0024	05	F52005	B8 FW CAD		4.000	EA	4	
0025	07	F53007	B-32 HEX NUT, SS		2.000	EA	4	
0026	01	238549	BOLT, HEX, ST #312-24 X 1.000		4.000	EA	4	
0027	01	238550	NUT, HEX #312-24		4.000	EA	4	
0028	06	235939	MASHER, FLAT 5/16	CAD PLATED	12.000	EA	4	
0029	01	108913	U-BOLT	MCC	2.000	EA	2	
0030	03	235940	NUT, HEX, ST #312-18	CAD PLATED	4.000	EA	4	
0031	01	108907-3	ASSY, TUBE 2"	MCC	1.000	EA	1	
0032	01	238551	UNION, 2"	PRK 32-HTR-S	1.000	EA	4	
0033	01	238552	CONNECTOR, MALE 1"	PRK 16-16-PTR-S	1.000	EA	4	
0034	01	238553	CONNECTOR	CON NS310610SL-45	2.000	EA	4	
0035	01	108934	LABEL, WRF	MCC	1.000	EA	4	
0036	05	F51250	Ø2 X .250 DRIVE SCREW		4.000	EA	4	
0037	06	F54015	LOCTITE		4.000	EA	4	

FIGURE 11. WRF ASSY. (2 OF 2)

This approach achieves a zero in 10,000 pulses from the B (recirculating) stream meter, and required only approximately 20 seconds.

Testing was conducted using an Anadex PI-608 frequency to DC converter. This testing resulted in a revised pulse output circuit to reduce pulse to pulse jitter.

System testing with the flowmeter revealed that the electronic subtracter network did not have adequate range to accept the instantaneous A to B input ratio differences caused by phasing between the two flowmeters. The circuitry was revised to replace the subtracter network with an up/down counter.

All changes were incorporated, and a printed circuit board assembly (PCBA) and enclosure were created.

Figure 12 is a photograph of the conditioner front panel. Figure 13 is a photograph of the conditioner rear panel indicating inputs and outputs.

The individual meter inputs, amplified and doubled in frequency are supplied to connectors at the rear of the conditioner enclosure. See Figure 14 for the conditioner assembly drawing.

All final system testing was conducted using the final PCBA version of the electronics.

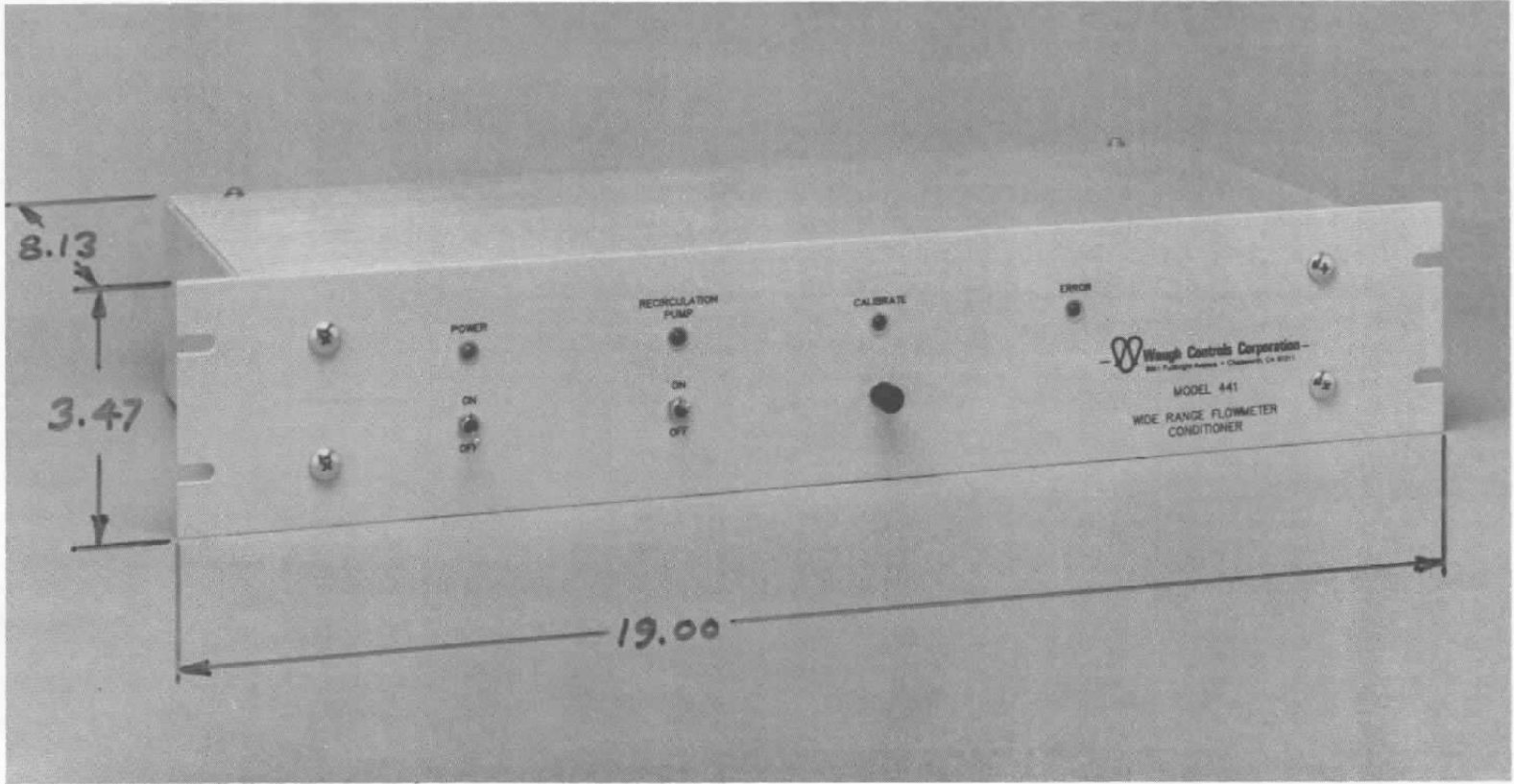

FIGURE 12. CONDITIONER FRONT PANEL

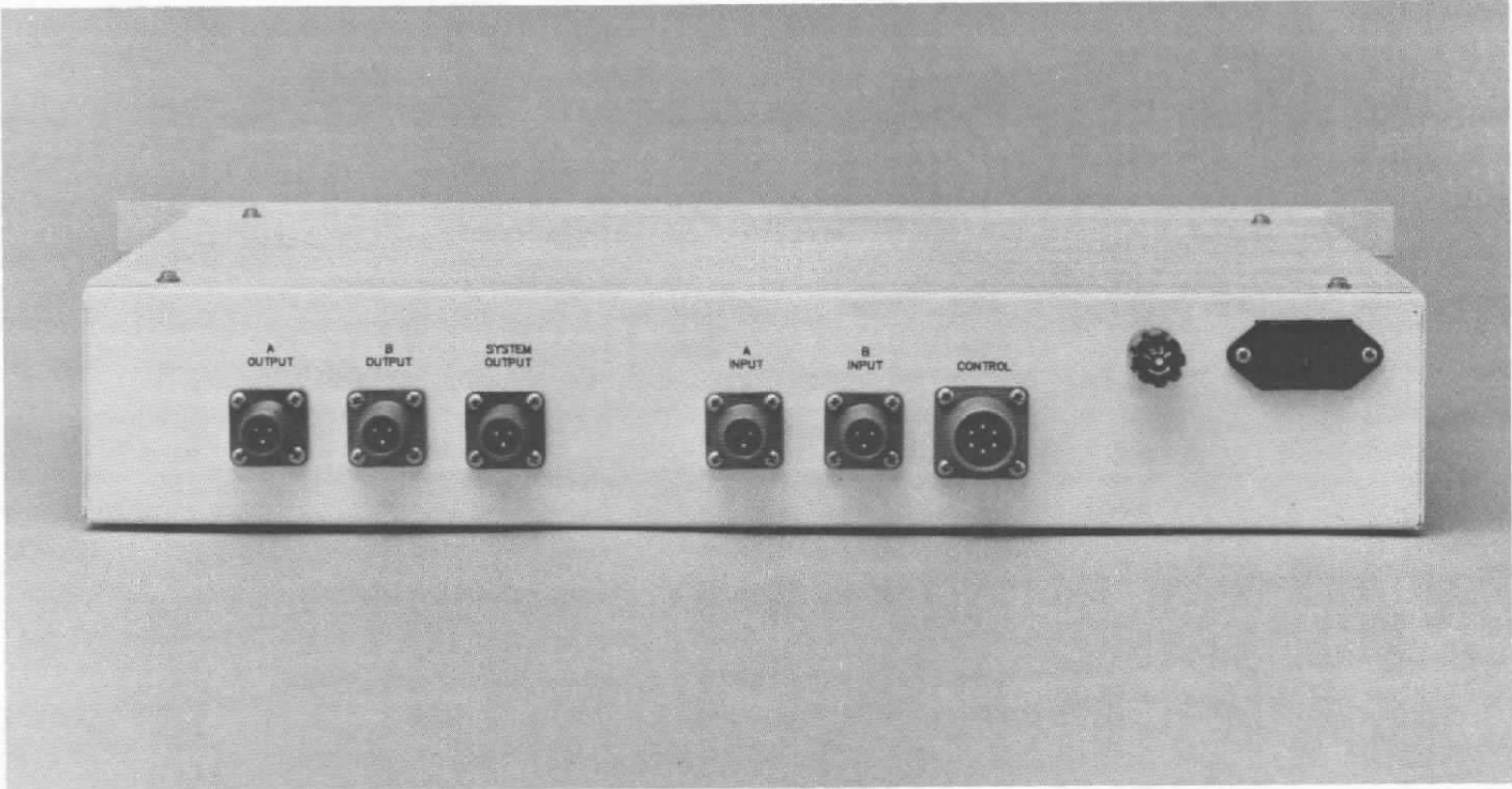

FIGURE 13. CONDITIONER REAR PANEL

PRINT PHANTOM ITEMS
 PRINT COMPONENTS
 PRINT PHANTOM COMPONENT COMMENTS

PARENT ITEM	CROSS REF	ITEM	DESCRIPTION	ASSY. SIB	COND	WFFF	MCC	BATCH	QTY	1	ITEM TYPE	1
100930			FREQ. DRUM					LFEEC	3/01/88		UNIT	MEAS EA
DOM	LL	COMPONENT	DESCRIPTION	ENGINEERING	QUANTITY	ITEM	OPT	FIRST	LT			
ITEM	CD	CROSS REF.	COMMENT	DRAWING NUMBER	PCR	UN	TYP	NBR	UP	SEC	ADJ	
0001	01	100512	ENCLOSURE	MCC	1.000	EA	2					
0002	01	109376	ASSY. P.C. BU. FLOWMETER	MCC	1.000	FA	1					
0005	02	230716	FILTER, RFI	CRM 6E-FI	1.000	EA	4					
0006	05	230001	FUSE, HOLDER	LTF 342994	1.000	EA	4					
0007	33	234029	FUSE, 1/2 AMP	LTF 312.900	1.000	EA	4					
0008	04	230062	CONN	CON MS3102A-10SL-3P	5.000	EA	4					
0009	01	233990	CONN	CON MS3102E-24-6P	2.000	EA	4					
0012	01	230973	SWITCH, TOGGLE	CAK 7101/SYZU	2.000	EA	4					
0013	01	231014	SWITCH, PUSHBUTTON	CAK 8121	1.000	EA	4					
0014	01	230049	LAMP, HOLDER	MAT MS600-3	1.000	EA	4					
0015	02	235011	LED, (FRUSTED DRG)	MDM MV5153	1.000	EA	4					
0016	06	231277	LED	MAT MS15046	3.000	EA	4					
0017	01	237514	CONN, 3 PIN LOCK 24 GA	PAN CE10F24-3	2.000	EA	4					
0018	04	237515	CONN, 6 PIN LOCK 24 GA	PAN CE10JF24-6	1.000	EA	4					
0019	34	237625	CONN, 9 PIN 24GA	PAN CE10JF24-9	1.000	EA	4					
0022	04	233023	STANDOFF, 1/4" HEX # 7-16	ATN 6214-B-0632-3A	7.000	EA	4					
0023	05	F51146	10-32X0.500 MS PAN PH CAD		4.000	EA	4					
0024	04	F51086	6-32X0.250 MS PAN PH SS		7.000	EA	4					
0025	05	F51041	4-40X0.250 MS PAN PH SS		26.000	EA	4					
0026	06	F51039	4-40X0.250 MS PAN PH SS		4.000	EA	4					
0027	05	F53009	10-32 HEX NUT, CAD		4.000	FA	4					
0028	08	F53003	4-40 HEX NUT, SS		26.000	EA	4					
0029	03	F52031	810 SPLIT LW, CAD		4.000	EA	4					
0030	05	F52029	80 SPLIT LW, CAD		14.000	EA	4					
0031	08	F52028	84 SPLIT LW, CAD		26.000	EA	4					
0033	01	230074	CONN	CON MS3106E-10SL-3S	5.000	EA	4					
			MATE FOR J5-JY									
0034	01	233000	CONN	CON MS3106E-14S-6E	1.000	EA	4					
			MATE FOR J10									
0035	04	231448	CORDELINE	BFL 17250	1.000	EA	4					

FIGURE 14. ASSY., SIGNAL CONDITIONER (2 of 2)

The WRFF electrical specifications are:

Inputs:

Power input: 115 VAC at 10 watts
Input amplifiers A and B each:
amplitude: 50 mV P-P to 50 VP-P
shape: sine or square wave
frequency: 4 Hz to 4 kHz
input impedance: minimum 10 K ohm

Outputs A1 and A2:

TTL compatible: 0 to +5 volts
50 u sec wide
output current: 0.015 amp each maximum
frequency: 2 times corresponding input frequency

Output Pulse (A-B):

TTL compatible: 0 to +5 volts
output approximates a square wave
output current: 0.015 amp maximum

Recirculating Pump Control:

+5 volt at 0.025 amp maximum
output controlled by front panel ON-OFF switch

3.5 System Uncertainty Analysis.

A system analysis was conducted over a flow range of 0.5 to 180 GPM. The possible errors evaluated stem from two sources:

Errors caused by flowmeter repeatability
Errors caused by scaler zero variation

3.5.1 Flowmeter Repeatability.

The analysis was conducted to determine the system error that could occur as a result of +0.02% repeatability in both the main stream and recirculating flowmeters.

The recirculation flow was assumed constant at 24 GPM over the system test range.

The uncertainty attributable to the mainstream meter was determined by multiplying the flow through the meter at each flow rate by $\pm 0.02\%$. Since the recirculating meter is operating at a constant flow rate of 24 GPM its contribution is $24 \times .02\%$, or a constant error of $\pm .0048$ GPM throughout the entire flow range.

The errors were summed, and the system error in % was calculated based on the system flow rate.

Since the error contributed by the recirculating flow meter becomes a significantly smaller percent of the system error at high flow rates the error approaches that of the mainstream meter only.

See Table 4 for results.

3.5.2 Scaler Zero Variation.

The calibration factors of the two turbine flow meters used in the WRFFF have very close to a .3500 ratio.

Referring to Figure 2 and signal conditioner description 1.2.2

To provide the best possible resolution in the four digit scaler when the meter ratios are .5000 or less divider No. 1 is in the divide by two position. This provides an actual registration in the scaler of .7000. To accommodate the division by two in divider No. 2 to present the proper ratio to the subtracter circuit, we will present the ratio as .7000.

The signal conditioner processes the input signals as follows:

$$F_s = F_2 - R F_1 \quad \text{where} \quad F_s = \text{System output freq.}$$

$$F_2 = 2" \text{ meter freq. in.}$$

$$F_1 = 1" \text{ meter freq. in.}$$

$$R = \text{Ratio} = \frac{.7000}{2}$$

The recirculation flow is presumed constant at 24 GPM.

The calibration factor of the 2" meter is 474 pulses/gallon.

During electronic zero

$$F_s = 0$$

$$F_2 = \frac{474 (24)}{60} = 189.60$$

$$0 = 189.60 - \frac{.7000}{2} F_1$$

$$F_1 = 541.71 \text{ Hz for all system flow rates}$$

To calculate the error introduced by $\pm .0001$ variation in the scaler ratio at 1.0 GPM mainstream flow:

$$F_2 = \frac{474 (25)}{60} = 197.50 \text{ Hz}$$

$$F_s = 197.50 - \frac{.7000}{2} 541.71 = 7.9015$$

$$F_s \text{ at } \frac{.7001}{2} = 197.50 - \frac{.7001}{2} 541.71 = 7.8744$$

$$\% \text{ Dev} = \frac{(7.9015 - 7.8744)}{7.9015} 100 = \pm .34\%$$

TABLE 4. FLOWMETER REPEATABILITY UNCERTAINTY ANALYSIS

<u>SYSTEM FLOW RATE (GPM)</u>	<u>MAINSTREAM MTR FLOW (GPM)</u>	<u>MAINSTREAM MTR ERROR (GPM)</u>	<u>CIRCULATION MTR ERROR (GPM)</u>	<u>TOTAL ERROR (GPM)</u>	<u>SYSTEM ERROR (%)</u>
0.5	24.5	$\pm .0049$	$\pm .0048$	$\pm .0097$	± 1.94
1.0	25.0	$\pm .0050$	$\pm .0048$	$\pm .0098$	$\pm .98$
1.31	25.31	$\pm .0051$	$\pm .0048$	$\pm .0099$	$\pm .76$
2.0	26.0	$\pm .0052$	$\pm .0048$	$\pm .0100$	$\pm .50$
4.0	28.0	$\pm .0056$	$\pm .0048$	$\pm .0104$	$\pm .26$
8.0	32.0	$\pm .0064$	$\pm .0048$	$\pm .0112$	$\pm .14$
15.0	39.0	$\pm .0078$	$\pm .0048$	$\pm .0126$	$\pm .084$
30.0	54.0	$\pm .0108$	$\pm .0048$	$\pm .0156$	$\pm .052$
60.0	84.0	$\pm .0168$	$\pm .0048$	$\pm .0216$	$\pm .036$
120.0	144.0	$\pm .0288$	$\pm .0048$	$\pm .0336$	$\pm .028$
180.0	204.0	$\pm .0408$	$\pm .0048$	$\pm .0456$	$\pm .025$

The error introduced by $\pm .0001$ scaler reading throughout the system flow rate is presented in Table 5.

TABLE 5. ZERO ERROR ANALYSIS

<u>SYSTEM FLOW RATE</u> GPM	<u>SYSTEM ERROR</u> (%)
0.5	$\pm .68$
1.0	$\pm .34$
1.31	$\pm .26$
2.0	$\pm .17$
4.0	$\pm .09$
8.0	$\pm .04$
15.0	$\pm .02$
30.0	$\pm .01$
60.0	< .01
120.0	< .01
180.0	< .01

It should be noted that these errors could be reduced by adding an additional digit to the scaler with proportionally longer zeroing time.

The error analysis is presented graphically in Figure 15.

The inner solid deviation curves represent the errors which would result from $\pm .02\%$ flowmeter repeatability.

The outer dashed curves represent the added error potential of a ± 1 digit resolution in the electronic scaler.

For this presentation, all possible sources of error were considered cumulative.

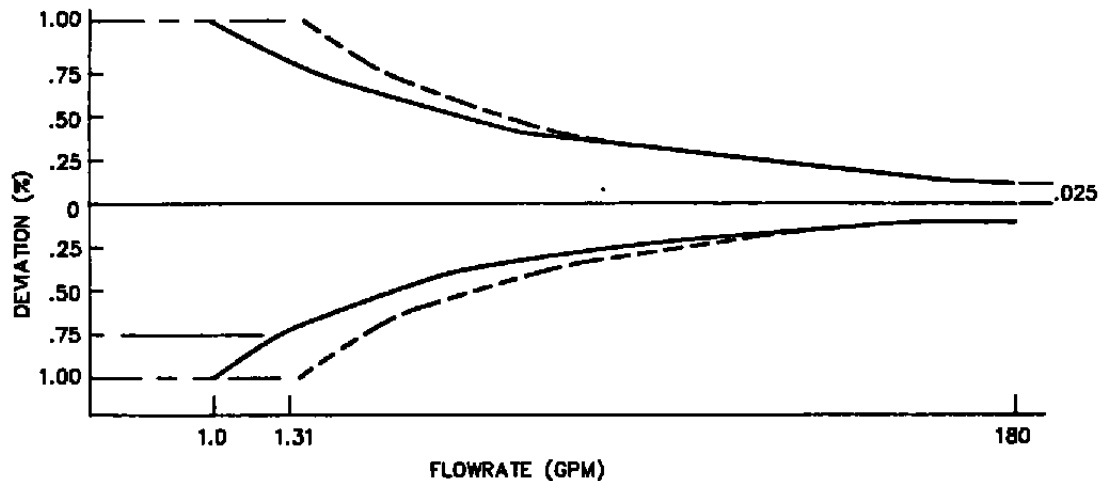

FIGURE 15. WRF UNCERTAINTY ANALYSIS

4 TESTS PERFORMED

4.1 General.

All testing was performed in accordance with Test Procedure 108935, Appendix A.

The procedure specifies test set ups, equipment used, tests to be performed, flow rates, calculations to be performed, and method of presenting results obtained.

It should be noted that the system specification requires $\pm 1.0\%$ accuracy over a flow range of 1.31 to 180 GPM. Testing was conducted down to 0.5 GPM to ascertain system performance at lower than specified flow rates.

Calibration data for flow rates from 0.5 GPM through 4.0 GPM were obtained using 2.0, 5.0, and 10.0 gallon, seraphin flasks. A start/stop button simultaneously activated a solenoid valve controlling flow to the seraphin flasks and gated counters collecting system pulses and the individual 2" and 1" meter pulses. A timer was also gated by the start/stop button providing run time to better than .01 second.

Data for these runs were recorded manually at the completion of each test on data sheets provided. Actual test volume was adjusted using the \pm neck reading of the seraphin flasks recorded at the completion of each run.

Testing was conducted twice at each flow rate as verification of system repeatability.

Calibration data from 8.0 through 180 GPM were obtained using a Waugh Controls Model 700 Microprover. This unit has a flow rate range of 3.0 to 3,000 GPM and an accuracy of .02%. This unit with

its micro processor controller provides gates, averages two consecutive test runs, and provides a print out of system meter counts, meter calibration factor, and test flow rate. The pulses from the individual 1" and 2" meters were gated by the micro processor and recorded manually at the end of the test on the data sheets provided.

4.2 Mainstream Meter Calibration.

The system was installed in our calibration facility and the system was purged of air. The mainstream flow was shut off downstream of the meter and the WRFF conditioner was zeroed. The recirculation pump was turned off and the recirculation shut off valve was closed. Mainstream flow was initiated, and a prover calibration was conducted from 20 to 200 GPM at 20 GPM increments.

4.3 WRFF System Calibration.

The system was purged of air and the conditioner was zeroed. A full span calibration from 0.5 to 180 GPM was conducted. The test stand 3 HP pump was used for flow rates from 0.5 GPM through 60 GPM, and the 40 HP pump was used for 120 and 180 GPM test points. The pump transition point was selected to, as nearly as possible, maintain a constant supply pressure at the WRFF. The 3 HP pump provided 58 psi at 0.5 GPM decaying to 48 psi at 60 GPM. The 40 HP pump provided 54 psi at 120 GPM, and 46 psi at 180 GPM.

4.4 Low Pressure Calibration.

One of the program requirements was to determine the effects of supply pressure variations on system performance.

The system was purged and the conditioner was zeroed. A calibration was conducted from 0.5 to 180 GPM maintaining the pressure at the WRFF at approximately 20 psi for all flow rates.

This pressure was achieved by simultaneously adjusting the test stand throttling valve downstream of the WRF and a test stand by pass valve which returned pump discharge fluid directly to the test stand reservoir.

The 20 psi pressure was selected as a result of test facility limitations; at pressures somewhat below 20 psi, the Microprover piston would not launch and travel downstream.

4.5 Stability Verification.

The object of this test was to determine the time interval over which specified accuracy can be achieved without zero resetting.

As a result of the simplicity and short period of time required to re-zero the system with the new auto-zero circuitry incorporated in the Phase II unit (approximately 20 seconds) it was assumed that in normal service the system would be re-zeroed prior to each test or work shift.

With this in mind, it was originally planned to conduct three system calibrations over a period of approximately eight hours.

However, due to longer than anticipated calibration times, and some test stand malfunctions, a much more severe test was actually conducted.

The malfunction referred to was in the form of "bounce" in the relay circuit used to control the solenoid valves used for Seraphin flask calibrations. Periodically, the valve to the seraphin flask would see a double pulse and shut off and then reopen resulting in overflow of the flask.

The system was zeroed at 3:30 P.M. on 1-20-88. The test was aborted after three data points had been obtained due to the above mentioned malfunction. Filtering was added to the circuiting in an attempt to eliminate this problem.

The test was restarted at 7:50 A.M. 1-21-88 without re-zeroing to:

1. Verify test stand performance
2. Determine whether the unit would perform satisfactorily after being idle overnight

The test was completed satisfactorily.

At 3:55 P.M. 1-21-88, a repeat calibration was initiated. Recurring problems with the solenoid valve controller forced suspension of testing at approximately 5:00 P.M.

The control box providing gates to the solenoid valves and counters was replaced with a different unit.

The test started on 3:55 P.M. 1-21-88 was resumed 11:00 A.M. on 1-22-88. Testing was completed 2:05 P.M. 1-22-88.

During the period 1-20-88 through 1-22-88, the system had been operated approximately 13 hours and forty five minutes and had been idle in the test stand for two nights.

4.6 Transient Response.

Tests were conducted to verify that the transient response of the system was 0.5 seconds or less.

All transient tests utilized an Anadex PI-608 f-DC converter driving a Sanborn Model 60-1300B strip chart recorder. The recorder was operated at a chart speed of 100 MM/second to record the transient.

4.6.1 Bench Test.

Initial bench tests were performed using Anadex Model FS-600 frequency synthesizers to simulate the turbine meter inputs. These tests permitted an instantaneous change in input frequency to be presented to the unit under test.

Bench tests were conducted on the Anadex f-DC converter only and on the WFFF signal conditioner driving the converter. These tests, when compared to the actual fluid calibration will indicate the portion of the transient time attributable to the WFFF and the Anadex f-DC converter respectively.

4.6.2 System Test.

The system was purged of air and the WFFF signal conditioner was zeroed using the test stand 40 HP pump.

The throttling valve was adjusted to produce 180 GPM with the eight inch lever operated butterfly isolation valve fully open. The isolation valve was closed to produce 20 GPM flow. The amplitude of the Sanborn recorder was adjusted to provide approximately 80% chart width deflection between these two flow points.

The Sanborn recorder was adjusted to 100 MM/second and the isolation valve was opened as rapidly as possible.

4.7 Airmotor Pump Evaluation.

An airmotor driven pump was evaluated for possible use in the WFFF for operation in hazardous areas.

The pump evaluated has the same 316 stainless steel SC 100 Price pump head and is driven by a Gast Model 2 AM-NCC-43A air motor.

The unit requires approximately 12 SCFM at 65 psi for use in the WFFF application.

The air motor is considerably smaller and lighter than the 1/4 HP electric motor used, but it does of course require a well regulated source of clean dry air. A drip oiler is required at the air pressure inlet port. Since the injected oil is discharged with the air at the outlet muffler, operation tends to get a little messy.

The electric motor driven pump was removed from the system, and the air motor drive pump was installed.

Since earlier experience with this unit had indicated that the airmotor took some time to stabilize, (RPM and flow increase with constant air pressure) the system was operated for one half hour prior to zeroing the system.

The system mainstream flow was shut off and the airmotor air supply was adjusted to provide 24 to 25 GPM recirculation flow as indicated by the recirculation flowmeter to simulate conditions produced by the electric motor pump.

It was observed that the air pressure required to achieve the recirculation rate desired was 82 psi which was considered extremely high based on previous testing.

The system was zeroed, and a calibration was started. Because of our concern with the high air pressure required, a running check of the recirculation flow was made.

The recirculation flow increased approximately 10% and then appeared to stabilize. At this point in time, the airmotor had been operating approximately one hour including the preliminary half hour "warm up".

The test was aborted and the unit was returned to the zero flow condition. The air pressure was readjusted, and 65 psi produced the desired 24 GPM recirculation flow.

The unit was re-zeroed and a complete calibration was performed.

The air pressure was recorded at each flow rate, but was not adjusted during the test.

5 TEST RESULTS

5.1 General.

All results obtained are presented in graphic form.

Test numbers were assigned to all tests conducted, and all data sheets, calculation sheets, and graphs are identified.

Table 6 presents a summary of tests conducted.

Supporting test data and calculation sheets used to create the curves are presented in test number sequence in Appendix B.

It will be noted by those familiar with turbine flowmeter calibrations that the data for the individual calibration curves is presented in a slightly unorthodox manner.

Normally, the test data would be reduced to obtain a mean calibration factor, and the percent deviation would be calculated as equal plus/minus deviations about the mean factor presented. This provides the user the most meaningful information for his purposes, but it suffers from some shortcomings in a development program of this nature.

Presenting mean calibration factors and \pm deviations results in an accurate portrayal of the meter tested during a specific test, but it does not provide graphic evidence of variations from test to test. In addition, variations in underrange data obtained can greatly influence the curve and introduce errors within the specified operating range.

For these reasons, it was decided before testing started that deviations would be calculated from the calibration obtained at the maximum flow rate of the system. In addition, all system

TABLE 6 SUMMARY OF TESTS PERFORMED

Tests prior to 88-9 invalid because of configuration changes to the WRFF. Straightening tube bundles were removed and recirculation flow rate was increased from approximately 20 GPM to 24.5 GPM.

TEST NO.	TEST DATE	DESCRIPTION	COMMENTS	TEST DATA	FIGURE	TEST RESULTS	TEST PROCEDURE
				LOCATION - PAGE			
88-9	1-14-88	Mainstream Meter Calibration		84	54	51	73
88-10	1-18-88	Sys. Calibration - low flow		89	52	51	72
88-11	1-18-88	Sys. Calibration - high flow		90	52	51	72
	1-19-88	Transient Response			64	56	74
88-12	1-19-88	Low Press. Calib. - low flow		94	57	56	72
88-13	1-19-88	Low Press. Calib. - high flow		95	57	56	72
88-14	1-19-88		Void-inspection revealed				
88-15	1-19-88		Contaminant in 1" meter				
88-16	1-20-88		Void-test stand relay malfunction				
88-17	1-21-88	Stability Calib. - low flow		99	58	56	73
88-18	1-21-88	Stability Calib. - high flow		100	58	56	73
88-19	1-22-88	Stability Calib. - low flow		104	59	56	73
88-20	1-22-88	Stability Calib. - high flow		105	59	56	73
88-21	1-25-88		Void-airmotor speed drift				
88-22	1-25-88	Airmotor Sys. Calib. - low flow		109	65	62	74
88-23	1-25-88	Airmotor Sys. Calib. - high flow		110	65	62	74

calibration deviations were calculated using the 180 GPM calibration (474.72 pulse/gallon) of the original system calibration (Figure 16) as 0% deviation. In this way, deviations from test to test are graphically apparent at both the maximum and minimum flow rates.

A conventional, composite, calibration curve of all system tests conducted is presented as Figure 17. This curve was derived from all of the data obtained within the specified operating range of the system. The data was reduced to obtain the mean calibration ("K") factor and indicates a maximum deviation of $\pm 0.55\%$ over a range of 1.31 to 180 GPM.

5.2 Mainstream Meter Calibration. (Test No. 88-9).

The calibration curve obtained on the mainstream meter with the recirculation flow shut off is presented as Figure 18.

The system was linear within 0.33% from 20 to 200 GPM.

As anticipated, the recirculating flow meter output was zero for all flow rates, and the system and mainstream meter outputs were identical.

5.3 WRFF System Calibration. (Test No. 88-10 & -11)

The initial system calibration is presented as Figure 16. The maximum total deviation over the operating range is approximately 0.7%.

5.3.1 Recirculation Flow Rate

The data pertaining to the recirculation flow rate was extracted from the initial system calibration data sheets (pages 89 and 90), and the recirculation flow was calculated and plotted over a system flow rate range of 0.5 to 180 GPM. See Figure 19.

WIDE RANGE FUEL FLOWMETER

SYSTEM CALIBRATION

DATE: 1-18-88

TEST NO: 88-10 & 88-11

CALIBRATION FACTOR AT 180 GPM = 474.72 PULSES/GALLON

FIGURE 16. INITIAL SYSTEM CALIBRATION

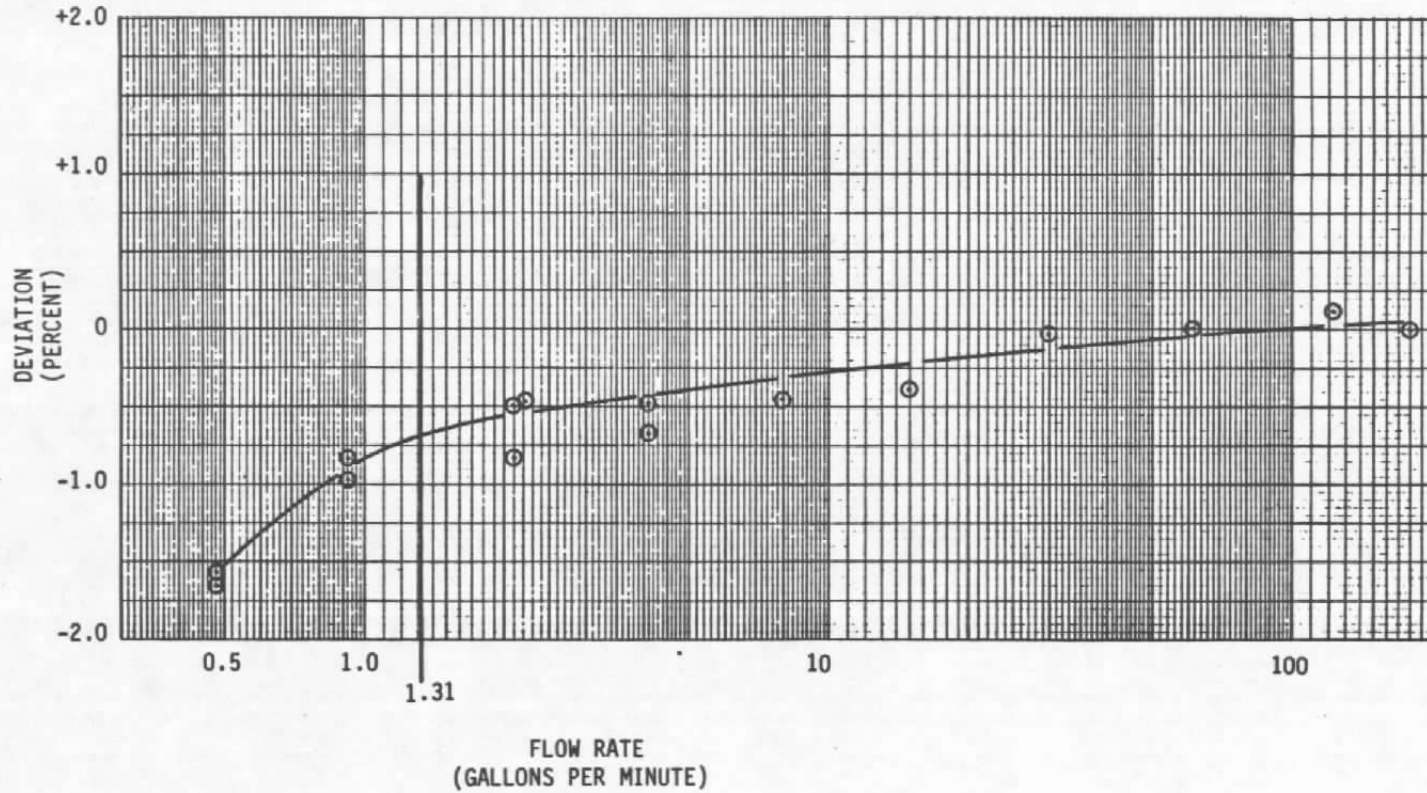

WIDE RANGE FUEL FLOWMETER

SYSTEM CALIBRATION

DATE: 2-2-88

TEST NO: _____

- ⊙ 88-10 & 11 1-18-88 SYS. CALIB MEAN K = 473.06
- △ 88-12 & 13 1-19-88 LOW PRESS. CALIB. MEAN K = 474.11
- 88-17 & 18 1-21-88 STABILITY CALIB. MEAN K = 472.26
- ⊙ 88-19 & 20 1-22-88 STABILITY CALIB. MEAN K = 473.10

FIGURE 17. COMPOSITE CALIBRATION CURVE

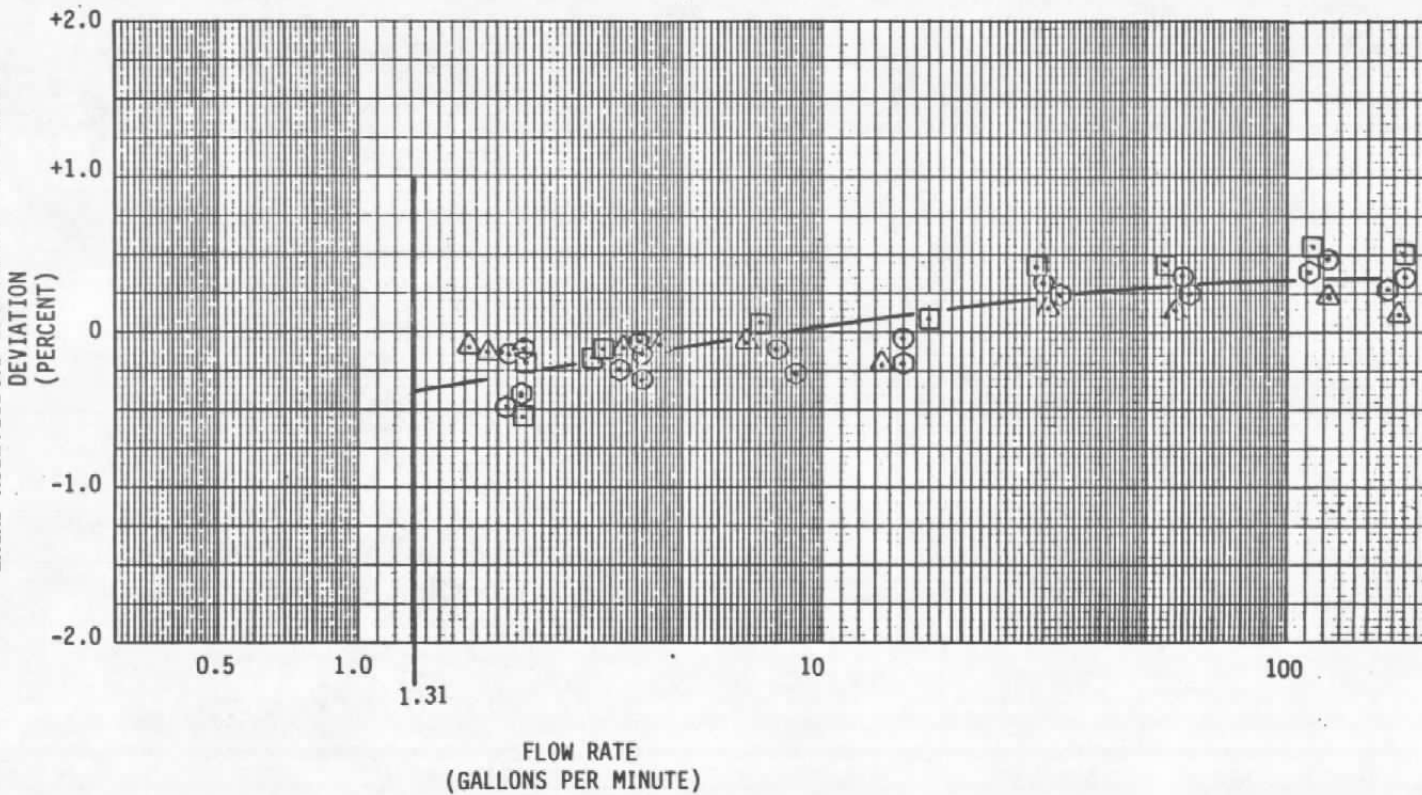

WIDE RANGE FUEL FLOWMETER
MAINSTREAM METER CALIBRATION

DATE: 1-14-88

TEST NO. 88-9

CALIBRATION FACTOR AT 200 GPM = 474.66 PULSES/GALLON

FIGURE 18. MAINSTREAM METER CALIBRATION

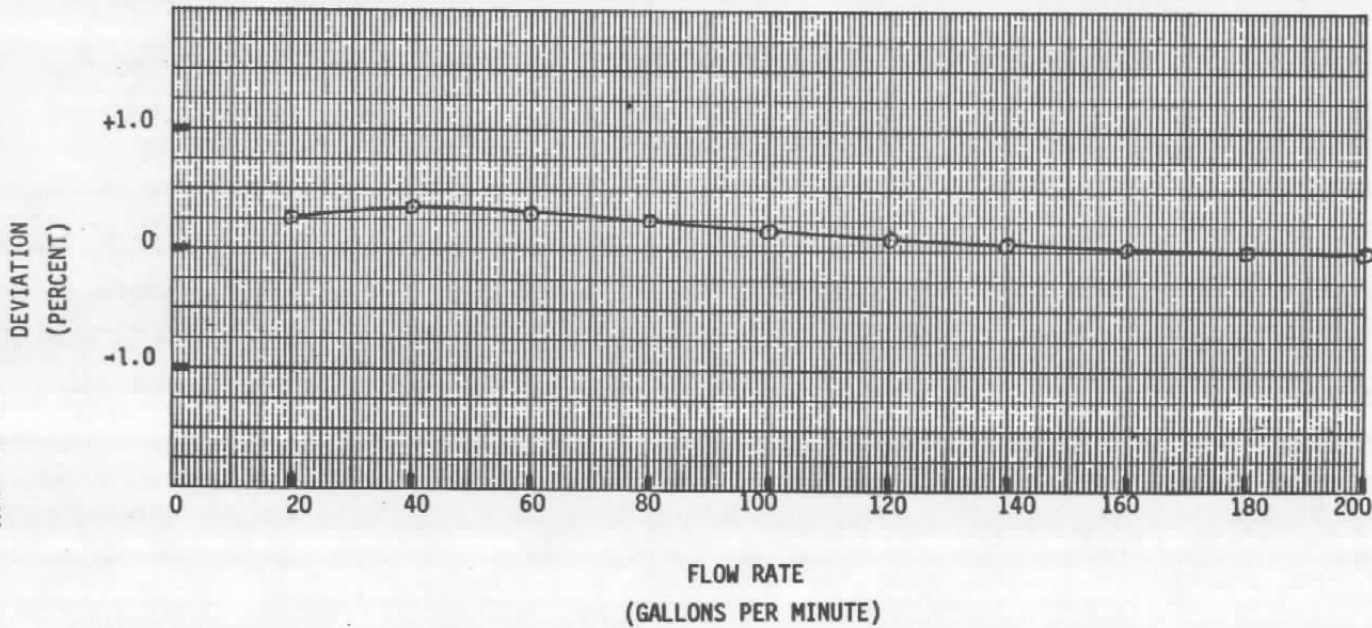

SYS. FLOW (GPM)	1" METER PULSES	TIME (SEC)	1" METER FREQ (HZ)	RECIRC. FLOW (GPM)
0.5	138333	248.68	556.27	24.65
1.0	177036	318.41	556.00	24.64
2.0	157991	284.16	555.99	24.64
4.0	81119	146.07	555.34	24.61
8.0	97069	174.728	555.54	24.62
15.0	50403	90.454	557.22	24.69
30.0	27185	48.637	558.94	24.77
60.0	13750	24.435	562.72	24.94
120.0	6892	12.055	571.71	25.33
180.0	4926	8.268	595.79	26.40

NOTE: Meter Pulses and time
extracted from Figure B.2.
Pages 89 & 90

1" Meter Calib. Factor
is 1354 Pulses/Gal.

$$\text{Flow (GPM)} = \frac{f(\text{Hz}) 60}{\text{Calib. Factor}}$$

FIGURE 19. RECIRCULATION FLOW RATE

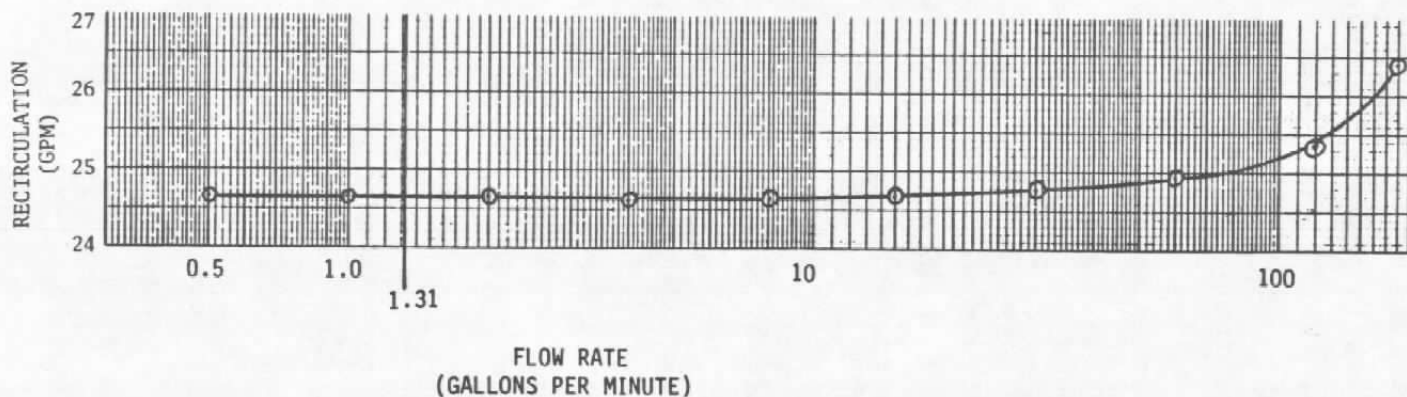

It is interesting to observe that the actual recirculation flow rates achieved are constant over a system flow rate of 0.5 to 10 GPM. This is the critical operating range of the WRFF as it is the range in which the recirculation meter non-repeatability or linearity produce substantial system errors which become insignificant at higher flow rates.

The injection and recovery means employed have actually induced a slight recirculation flow rate increase at higher system flows.

5.4 Low Pressure Calibration. (Test No. 88-12 & -13)

The calibration curve obtained with a constant 20 psi system pressure is presented as Figure 20. The maximum total deviation over the operating range is approximately 0.5%.

5.5 Stability Verification. (Test No. 88-17 through 88-20)

The first calibration conducted to verify long term stability is presented as Figure 21. At the time this calibration was completed, the system had been in operation for a period of approximately 9 hours and 30 minutes, and had been sitting idle in the test stand overnight since it had been zeroed at 3:30 P.M. on 1-20-88. At this time, the maximum total deviation over the flow range of 1.3 to 180 GPM was approximately 0.7%.

The final stability calibration is presented as Figure 22. At this time the system had accumulated approximately 13 hours and forty five minutes and had been idle twice overnight since it was originally zeroed.

5.6 Transient Response.

Figure 23 presents the results of bench tests conducted on the WRFF electronics and an Anadex f-DC converter indicating the WRFF electronics by itself has a virtually zero time constant.

The tests were conducted using Anadex Model FS-600 Frequency Synthesizers driving the Anadex converter or the WRFF electronics.

WIDE RANGE FUEL FLOWMETER

SYSTEM CALIBRATION

DATE: 1-19-88

TEST NO: 88-12 & 88-13

CALIBRATION FACTOR AT 180 GPM = 474.62 PULSES/GALLON

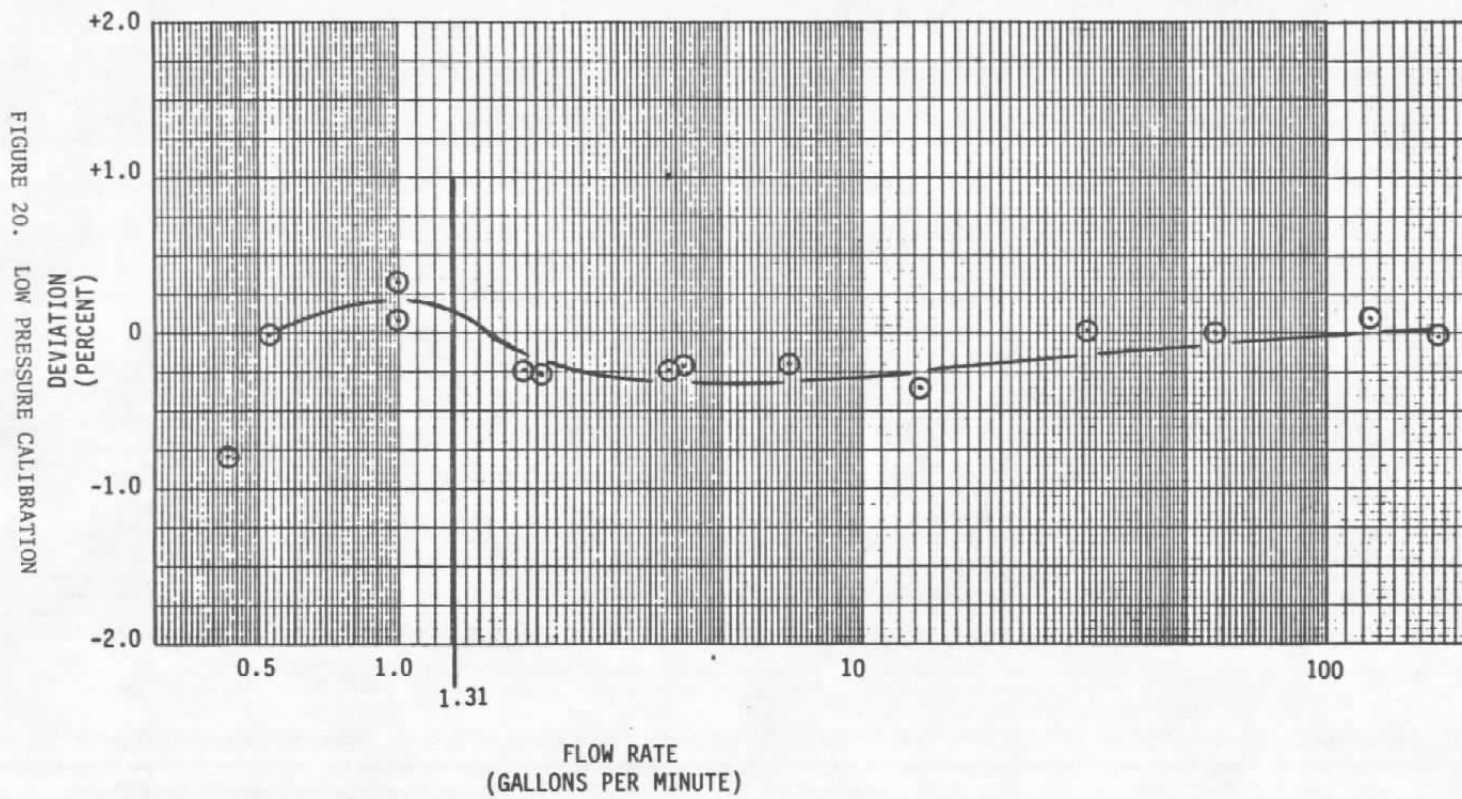

WIDE RANGE FUEL FLOWMETER

SYSTEM CALIBRATION

DATE: 1-21-88

TEST NO: 88-17 & 88-18

CALIBRATION FACTOR AT 180 GPM = 474.64 PULSES/GALLON

FIGURE 21. STABILITY CALIBRATION NO. 1

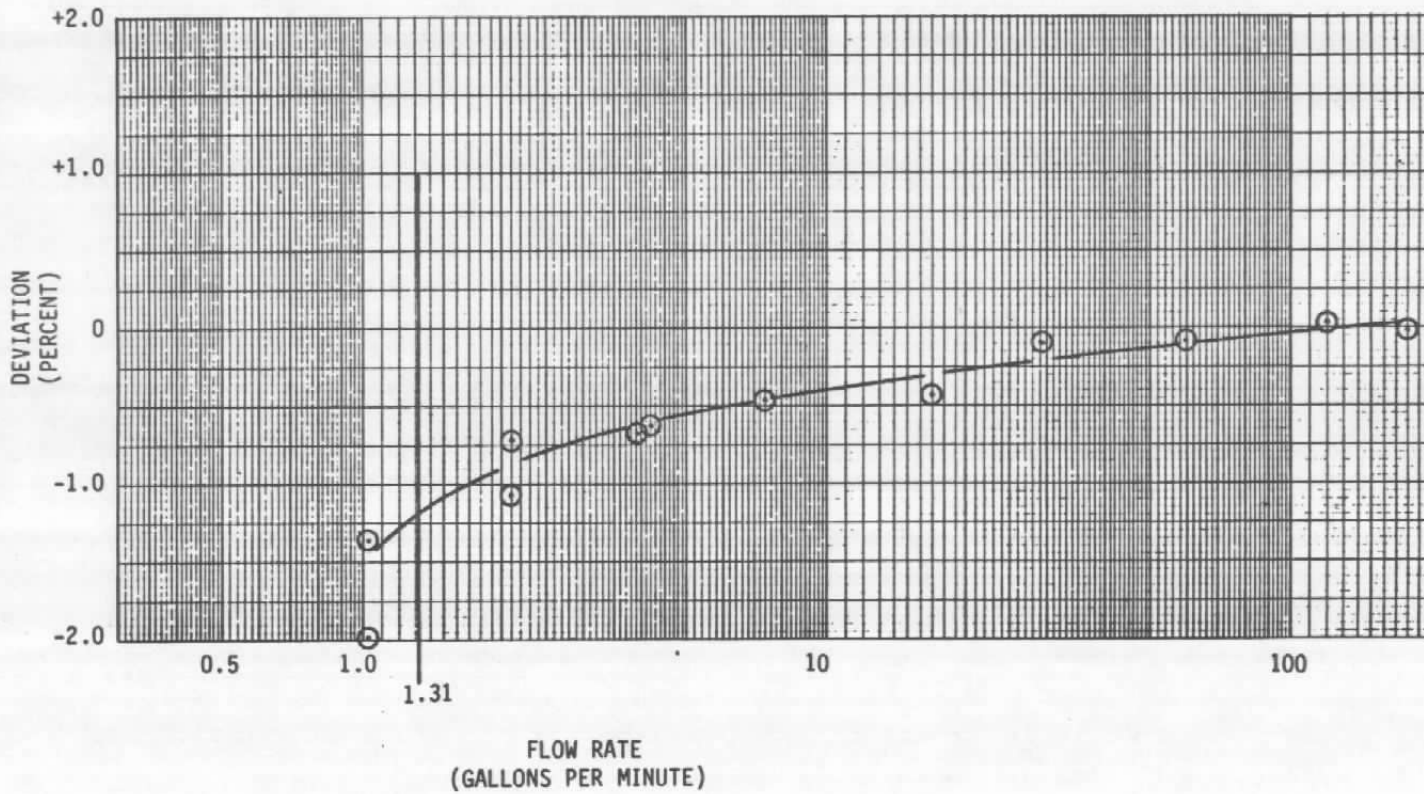

WIDE RANGE FUEL FLOWMETER

SYSTEM CALIBRATION

DATE: 1-22-88

TEST NO: 88-19 & 88-20

CALIBRATION FACTOR AT 180 GPM = 474.44 PULSES/GALLON

FIGURE 22. STABILITY CALIBRATION NO. 2

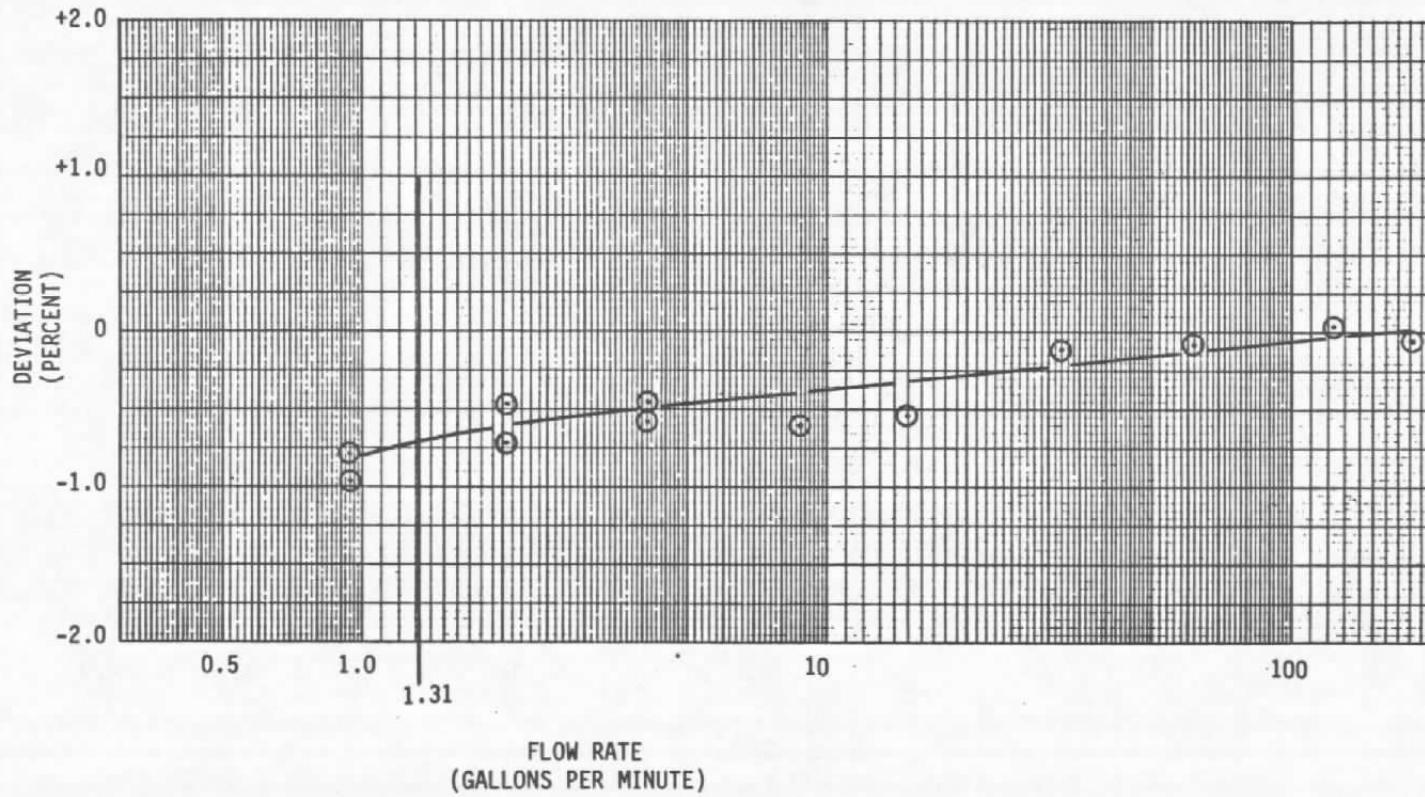

The Anadex output was recorded on a Sanborn Model 60-1300B strip chart recorder at a paper speed of 100 MM per second.

The chart of Figure 23A presents the output of the Anadex converter alone, while the chart of Figure 23B indicates the transient response output of the Anadex converter driven by the WRFF electronics subjected to an instantaneous frequency change.

The transients were created by flipping a toggle switch to switch input frequencies, and no significance can be attributed to the spacing of the transients shown.

These tests were conducted using range 5 of the Anadex converter set for a full scale frequency of 1,600 Hz.

All tests were conducted with worst possible conditions for ripple and to achieve the best possible transient response; WRFF " + 1" and Anadex "High" transient response setting.

Some explanation of the functioning of the WRFF electronics is required for clearer understanding of the frequencies used in these tests.

The frequencies in all cases were selected as typical of those observed during system testing.

Thus, the frequencies of 1422 and 158 Hz at 180 and 20 GPM of chart Figure 23A are representative of the WRFF system output with a calibration factor of 474 pulses/gallon.

The WRFF electronics operates by subtracting the recirculating flow from the flow seen by the mainstream meter. To compensate for the different calibration factors of the two flowmeters, a four digit "scaler" is selected during the zero cycle and is applied to the recirculating meter output. This scaler is merely the ratio of the meter outputs at a given flow rate, and a typical value is .3459.

$$\text{Thus: } f_s = f_2 - R (f_1)$$

Where f_s = system frequency output

f_2 = frequency of the mainstream (2") meter

f_1 = frequency of the recirculating (1") meter

$$R = \text{scaler} = \frac{f_2}{f_1} = .3459$$

The input frequencies to be applied to the WRFF electronics for the test of Figure 23B were determined as follows:

Referring to Figure 23B at 20 GPM:

f_2 input is to be determined

f_s output is 158 Hz

$f_1 = 482$ Hz (typical of 21.1 GPM recirculation)

$R = .3459$

$$f_s = f_2 - R(f_1)$$

$$f_2 = f_s + R(f_1) = 158 + .3459 (482) = 324.7 \text{ Hz}$$

At 180 GPM:

$f_s = 1422$ Hz

$$f_2 = 1422 + .3459 (482) = 1588.7 \text{ Hz}$$

It can be seen that the outputs created by the WRFF conditioner from the two flowmeter inputs are exactly the same as provided by the single signal generator in Figure 23A after proper subtraction of the recirculation flow signal.

Figure 24 presents the results of an actual system hydraulic transient test.

The response time of the system to 63% of the step change provided is approximately 100 milliseconds. This includes the time required to manually open the butterfly valve and overcome the fluid inertia of the test facility, and the time constant of the Anadex frequency to DC converter.

5.7 Airmotor Pump Evaluation. (Test No. 88-22 & -23)

The results of a system calibration using a Gast airmotor driven pump to provide recirculation flow are presented as Figure 25. The deviation of the airmotor driven system over a flow range of 1.3 to 180 GPM was approximately 0.75%.

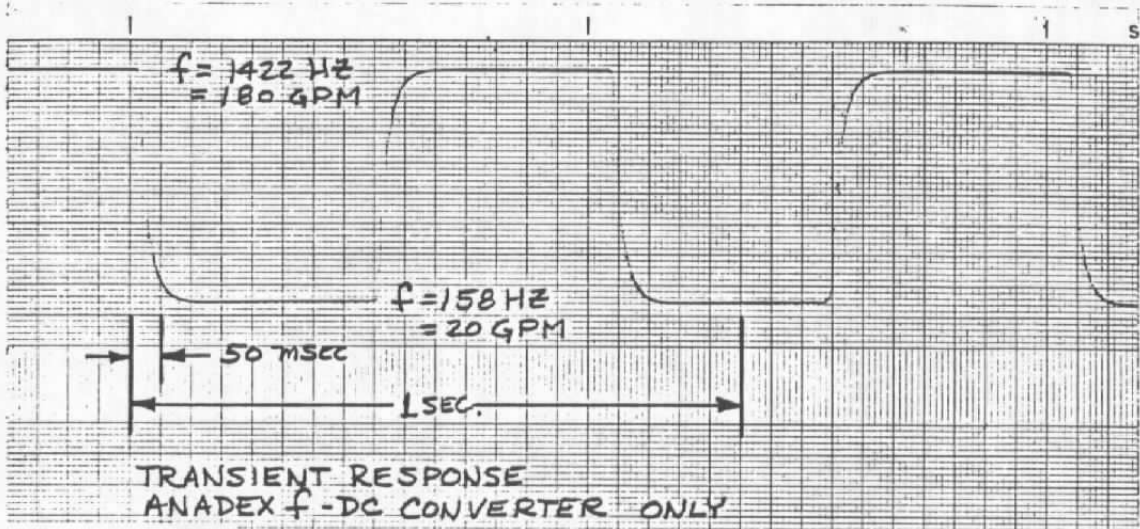

FIGURE 23A

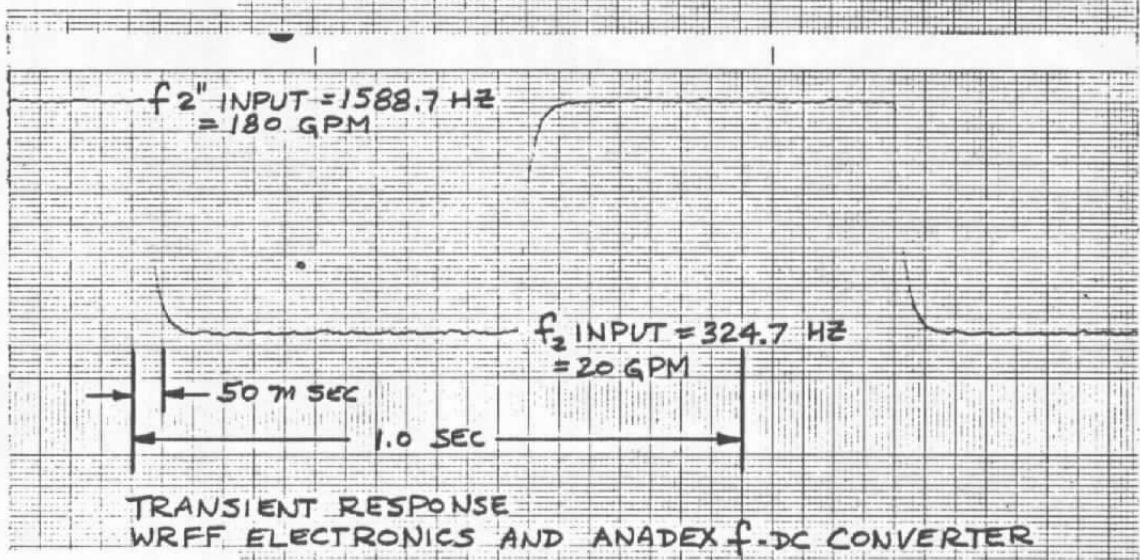

FIGURE 23B

$f_1 \text{ INPUT CONSTANT AT } 482 \text{ Hz (21.1 GPM)}$

FIGURE 23. TRANSIENT RESPONSE, BENCH TESTS

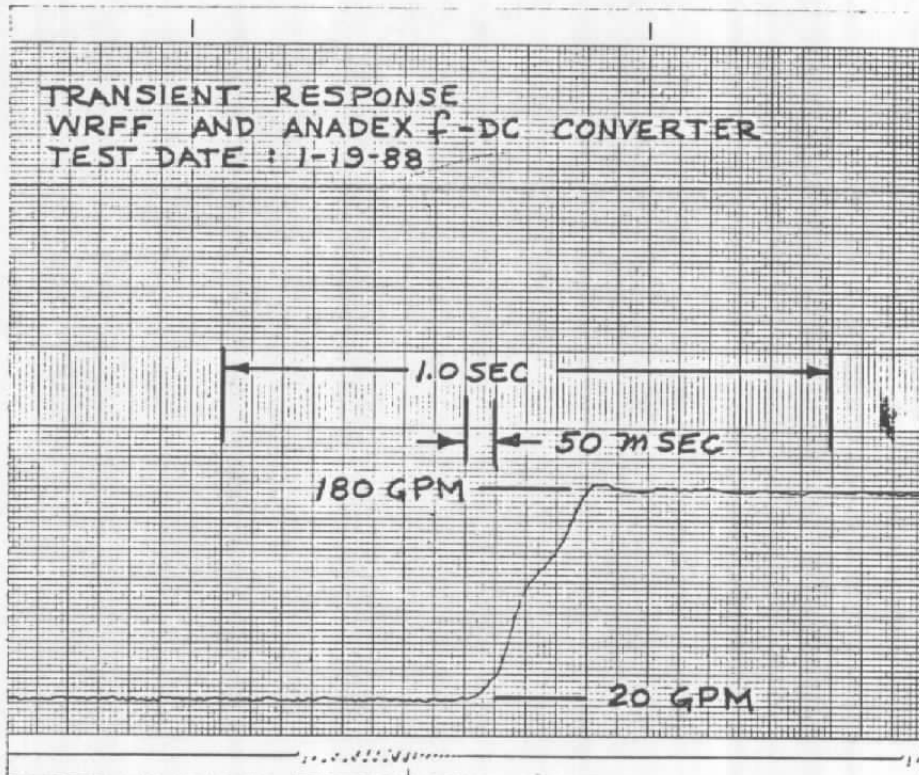

FIGURE 24. TRANSIENT RESPONSE, SYSTEM TEST

WIDE RANGE FUEL FLOWMETER

SYSTEM CALIBRATION

DATE: 1-25-88

TEST NO: 88-22 & 88-23

CALIBRATION FACTOR AT 180GPM = 474.28 PULSES/GALLON

FIGURE 25. AIRMOTOR SYSTEM CALIBRATION

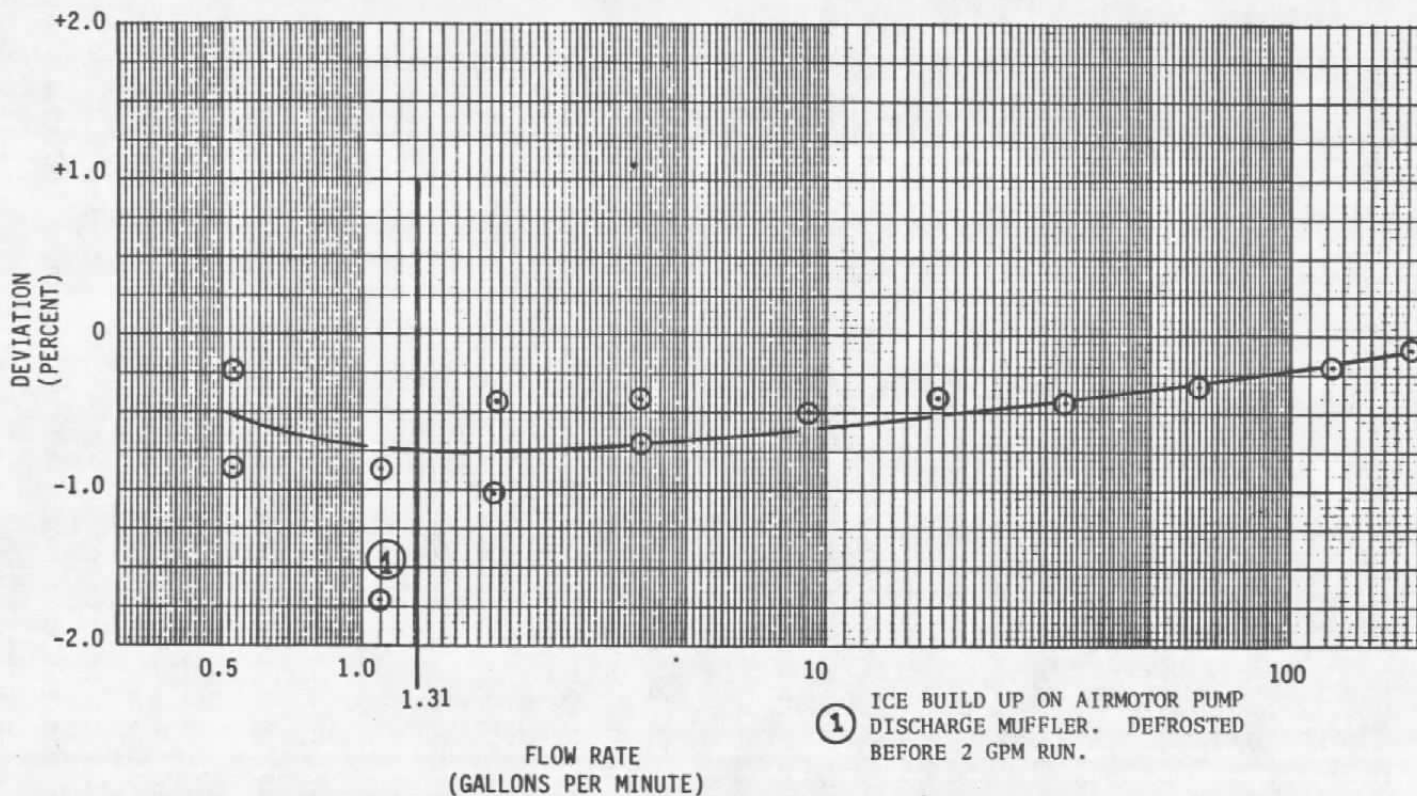

6. CONCLUSIONS

The WRF Contract Statement of Work called out certain specific performance requirements, design objectives, and tests to be performed.

These requirements were all satisfied as indicated below.

6.1 Performance Requirements

6.1.1 Flow Range and Accuracy

The WRF was to be capable of measuring the flow rate of aviation fuels over a flow range of 140 to 1 (1.31 to 183 GPM) with a 1.0% or better measurement uncertainty.

The composite calibration curve (Figure 17, page 53) covering all system tests conducted with the electric motor driven pump indicate that the unit is capable of providing flow measurement with an accuracy of $\pm 0.55\%$ over the flow range of 1.31 to 183 GPM.

It should be noted that the testing conducted during this period represents approximately 24 hours and 15 minutes including one period (stability tests No. 88-17 through 88-20) during which the system accumulated approximately 13 hours and 45 minutes and had been idle twice overnight since it was originally zeroed verifying good long term system stability.

6.1.2 Transient Response.

The statement of work specified that the system must be capable of measuring flow transients with a response time of 0.5 seconds or less.

As indicated in Figure 24, page 64, the time constant of the system (including the response of an Anadex PI-608 f-DC converter used to drive the Sanborn strip chart recorder and the time required to open an 8 inch manual butterfly valve) proved to be approximately 100 msec with a step change in flow rate from 20 to 180 GPM.

6.2 Design Objectives.

The design objective of the Phase II program was to bring the system produced in the SBIR Phase I effort into a more producible form, as follows:

6.2.1 Mechanical

- (1) Package the meter as small as practical.

The unit was repackaged as indicated in Figure 10, page 27. The resulting unit is 29.3 inches long, 13.1 inches deep, 8.7 inches high, and weighs 82 pounds.

This represents a considerable reduction over the unit delivered under Phase I which was 31 inches long, 28 inches deep, 19.5 inches high, and weighed 148 pounds.

- (2) Replace the recirculation pump with a smaller, more reliable unit compatible with jet fuels.

The price centrifugal pump selected is of all stainless steel construction. This unit is the smallest unit that will provide the recirculation flow required, and should prove extremely reliable.

- (3) Investigate further the availability of a suitable metering pump to replace the recirculation flow meter.

As indicated in paragraph 3.1, page 12, manufacturers of plunger, vane, and gear type metering pumps were contacted.

The combination of a centrifugal pump and recirculation flow meter proved to be superior to a metering pump in cost, size, weight and perceived reliability.

- (4) Provide means to disable the recirculating flow when not operating in the low flow range.

A shut off valve, item 9, of Figure 11, page 29 was incorporated to provide a means of shutting off the recirculation flow.

The conditioner was zeroed, and the system was calibrated without recirculating flow. The calibration curve obtained is presented as Figure 18, page 54.

The calibration factor (474.66 Pulses/Gallon) obtained at 200 GPM is within .013% of that obtained for the initial system calibration presented as Figure 16, page 52.

The unit was linear within 0.33% from 200 GPM to 20 GPM.

- (5) Investigate the advantages/disadvantages of an air-driven pump.

The air motor driven pump proved to be an acceptable alternative for use in hazardous areas. The motor took from one half to one hour to stabilize at a given air pressure. Once stabilized however the system provides a calibration with a maximum excursion of 0.9% from 1.31 to 180 GPM (Figure 25, page 65).

- (6) Investigate the effects of supply pressure variations.

A system calibration was performed over a flow range of 0.5 to 180 GPM maintaining the pressure at the WFFF at approximately 20 psi for all flow rates. See Figure 20, page 57 for results.

The calibration factor (474.62 Pulses/Gallon) at 180 GPM is within .02% of that obtained for the initial system calibration of Figure 16, page 52.

The calibration curve from 2.0 to 180 GPM exhibited only approximately 0.35% non linearity and was very similar to the initial system calibration from approximately 2.0 to 180 GPM.

Under range data obtained at 0.5 and 1.0 GPM indicate better performance than obtained on the initial system calibration; however, as indicated in Figure 15, page 41, data at these extreme flow rates is subject to considerable uncertainty, and the difference may more logically be attributed to small variations in flow meter repeatability or zeroing than line pressure variations.

6.2.2 Electronic

- (1) Repackage the electronic equipment into a more compact size suitable for rack or panel mounting.

The WRFF electronic conditioner has been repackaged in a standard 19 x 3.5 inch rack configuration (Figure 12, page 32).

- (2) Provide direct pulse outputs from each meter.

Figure 13, page 33, presents the conditioner rear panel configuration indicating the individual A and B flow meter output connectors.

The output signals provided are TTL compatible 0 to +5 volt 50 M second wide pulses at twice the flow meter input frequency.

APPENDIX A

TEST PROCEDURE

WIDE RANGE FUEL FLOWMETER

**TEST PROCEDURE
WIDE RANGE FUEL FLOWMETER**

1.0 SYSTEM PURGE & ZERO

1.1 System, Purge

Open test stand valves and flood system. Open Butterball valve and turn on WRFF recirculating pump. Turn on test stand 3HP pump and establish approximately 60 GPM. Bleed all air from prover and test stand.

1.2 WRFF Zero

Close isolation valve downstream of WRFF to eliminate mainstream flow. Press "calibrate" push button on WRFF electronics to zero.

2.0 WRFF CALIBRATION

Perform calibration from 0.5 to 180 GPM mainstream flow rate, recording all data indicated on calibration data sheets 1 & 2.

Flow rates 0.5 through 60 GPM to be run using 3HP pump. 120 & 180 GPM to be conducted using 40 HP pump.

Calculate % deviation as indicated on "Calculation Sheet - % Deviation".

3.0 WRFF LOW PRESSURE CALIBRATION

Conduct calibration from 0.5 to 180 GPM mainstream flow rate using 3 HP pump for flow rates 0.5 through 60 GPM and 40 HP pump for 120 and 180 GPM. Adjust stand by-pass valve to obtain approximately 20 PSI at WRFF at each flow rate.

Record all data indicated on calibration data sheets 1 & 2.

Calculate % deviation.

Note: For this test calculate % deviation using K (180) from 2.0 as zero deviation.

Upon completion of this test establish approximately 100 GPM mainstream flow using 3 HP pump and let run.

TEST PROCEDURE
WIDE RANGE FUEL FLOWMETER

4.0 STABILITY VERIFICATION

4.1 Four Hours

Four hours after performing the calibration of 2.0 above, repeat calibration.

Calculate % deviation.

Note: For this test calculate % deviation using K (180) from 2.0 as zero deviation.

Upon completion of this test establish approximately 100 GPM mainstream flow using 3 HP pump and let run.

4.2 Seven Hours

Seven hours after performing the calibration of 2.0 above, repeat 4.1.

Shut down system.

5.0 MAINSTREAM METER CALIBRATION

5.1 Purge & Zero per 1.0

5.2 Turn off WRF recirculating pump and close Butterball valve.

5.3 Conduct calibration from 20 to 200 GPM recording all data indicated on data sheet 3.

Flow rates 20 through 100 GPM to be run with 3 HP pump. 120 through 200 GPM to be run using 40 HP pump.

Calculate % deviation as indicated on data sheet.

Note: For this test P1 will be zero or essentially zero. P2 will equal PS.

**TEST PROCEDURE
WIDE RANGE FUEL FLOWMETER**

6.0 TRANSIENT RESPONSE

Connect output of WRFF electronics to Anadex Model PI-608 AC/DC converter. Connect output of converter to Sanborn Model 60-1300B strip chart recorder.

Purge & Zero system per 1.0

Using 40 HP pump, adjust throttling valve to produce 180 GPM with isolation valve fully open. Close isolation valve to produce 20 GPM flow.

Adjust amplitude of Sanborn to provide approximately 80% of chart width between these two points.

With isolation valve adjusted to 20 GPM, start Sanborn recorder at 100MM/Second paper speed.

Open isolation valve fully as rapidly as possible.

7.0 AIRMOTOR PUMP EVALUATION

Replace electric motor pump with Gast Air Motor driven pump.

Purge system per 1.1. Adjust air pressure to provide 24 to 25 GPM recirculating flow. Run air motor for one half hour to stabilize. Record air pressure supplied to motor.

Zero per 1.2.

Calibrate per 2.0.

TEST PROCEDURE
WIDE RANGE FUEL FLOWMETER

WIDE RANGE FUEL FLOWMETER
CALIBRATION DATA SHEET NO. 1
SERAPHIN FLASK CALIBRATION

DATE: _____

TIME-START: _____

AMB. TEMP. START: _____

STOP: _____

STOP: _____

TEST NO: _____

RECORDED DATA

NOM FLOW RATE (GPM)	TIME (SEC)	VOLUME (GAL)	+/-IN ³	PULSES			WATER TEMP (F)	SYS. PRESS (PSI)
				2"	1"	SYS		
.5		1.9982						
.5		1.9982						
1.0		5.0003						
1.0		5.0003						
2.0		9.9955						
2.0		9.9955						
4.0		9.9955						
4.0		9.9955						

CALCULATED

NOM. FLOW RATE (REF.)	TEST VOLUME (GAL)	TEST FLOW RATE (GPM)	K-FACTOR (PULSES/GAL)
.5			
.5			
1.0			
1.0			
2.0			
2.0			
4.0			
4.0			

DATA BY: _____

APPROVED: _____

**TEST PROCEDURE
WIDE RANGE FUEL FLOWMETER**

**WIDE RANGE FUEL FLOWMETER
CALIBRATION DATA SHEET NO. 2
PROVER CALIBRATION**

DATE: _____

TIME - START: _____

AMB. TEMP. START: _____

STOP: _____

STOP: _____

TEST NO.: _____

PROVER VOLUME: _____ GALLONS

RECORDED DATA

(1) TEST FLOW RATE (GPM), Ps, & K FACTOR-1010 COMPUTER PRINT OUT

NOM. FLOW RATE (GPM)	PULSES		WATER TEMP. (°F)	SYS. PRESS (PSI)	CALCULATED TIME (SEC.) (2)
	2"	1"			
8					
15					
30					
60					
120					
180					

NOTES:

DATA BY: _____

APPROVED: _____

Date 12/01/87
REV1-8-88 (1) DELETED-TIME(SEC)
(2) ADDED CALC. TIME

TEST PROCEDURE
WIDE RANGE FUEL FLOWMETER

WIDE RANGE FUEL FLOWMETER
CALIBRATION DATA SHEET NO. 3
MAINSTREAM METER CALIBRATION

DATE: _____

TIME - START: _____

AMB. TEMP. - START: _____

STOP: _____

- STOP: _____

TEST NO.: _____

PROVER TEST VOLUME = _____ GAL.

(1) TEST FLOW RATE (GPM), Ps, & "K" FACTOR-1010 COMPUTER PRINT OUT

NOM. FLOW RATE (REF)	PULSES		WATER TEMP. °F	K FACTOR (PULSES/GAL)	CALC % DEV.	CALCULATED TIME (SEC.) (2)
	2"	1"				
20						
40						
60						
80						
100						
120						
140						
160						
180						
200					-0-	

$$\% \text{ DEV.} = \frac{\left[\frac{K_{(TEST)} - K_{(200)}}{K_{(200)}} \right] \times 100}{K_{(200)}}$$

NOTES:

BY: _____

APPROVED: _____

Date 12/01/87
REV1-8-88 (1) DELETED-TIME(SEC)
(2) ADDED CALC. TIME

**TEST PROCEDURE
WIDE RANGE FUEL FLOWMETER**

**WIDE RANGE FUEL FLOWMETER
CALCULATION SHEET - % DEVIATION**

DATE: _____

TEST NO.: _____

NOM. FLOW RATE (REF)	TEST FLOW RATE (GPM)	K FACTOR (PULSES/GAL)	% DEV.
.5			
.5			
1.0			
1.0			
2.0			
2.0			
4.0			
4.0			
8.0			
15.0			
30.0			
60.0			
120.0			
180.0			-0-

% DEV. CALCULATED AS FOLLOWS:

$$\% \text{ DEV.} = \frac{\left[\frac{K_{(\text{TEST})} - K_{(180 \text{ GPM})}}{K_{(180 \text{ GPM})}} \right] \times 100}{K_{(180 \text{ GPM})}}$$

BY: _____

APPROVED: _____

TEST PROCEDURE
WIDE RANGE FUEL FLOWMETER

WIDE RANGE FUEL FLOWMETER

TEST EQUIPMENT LIST

<u>MANUFACTURER</u>	<u>DESCRIPTION</u>	<u>MODEL NO.</u>	<u>S/N</u>
ANADEX	F-DC CONVERTER	FI-608	
DIGITAL EQUIPMENT	PRINTER	DECWRITER II	
SANBORN	STRIP CHART RECORDER	60-1300 B	239
SERAPHIN	10 GALLON VESSEL	M	17118
	5 GALLON VESSEL	M	14260
	2 GALLON VESSEL	M	14836
WAUGH CONTROLS	MICROPROVER	700-08-15	10092
	PROVING COMPUTER	1010	
	PROVER COUNTER	670-1	
	MINICOUNTER	427	
	PRE-AMPLIFIER	A-11	

TEST PROCEDURE
WIDE RANGE FUEL FLOWMETER

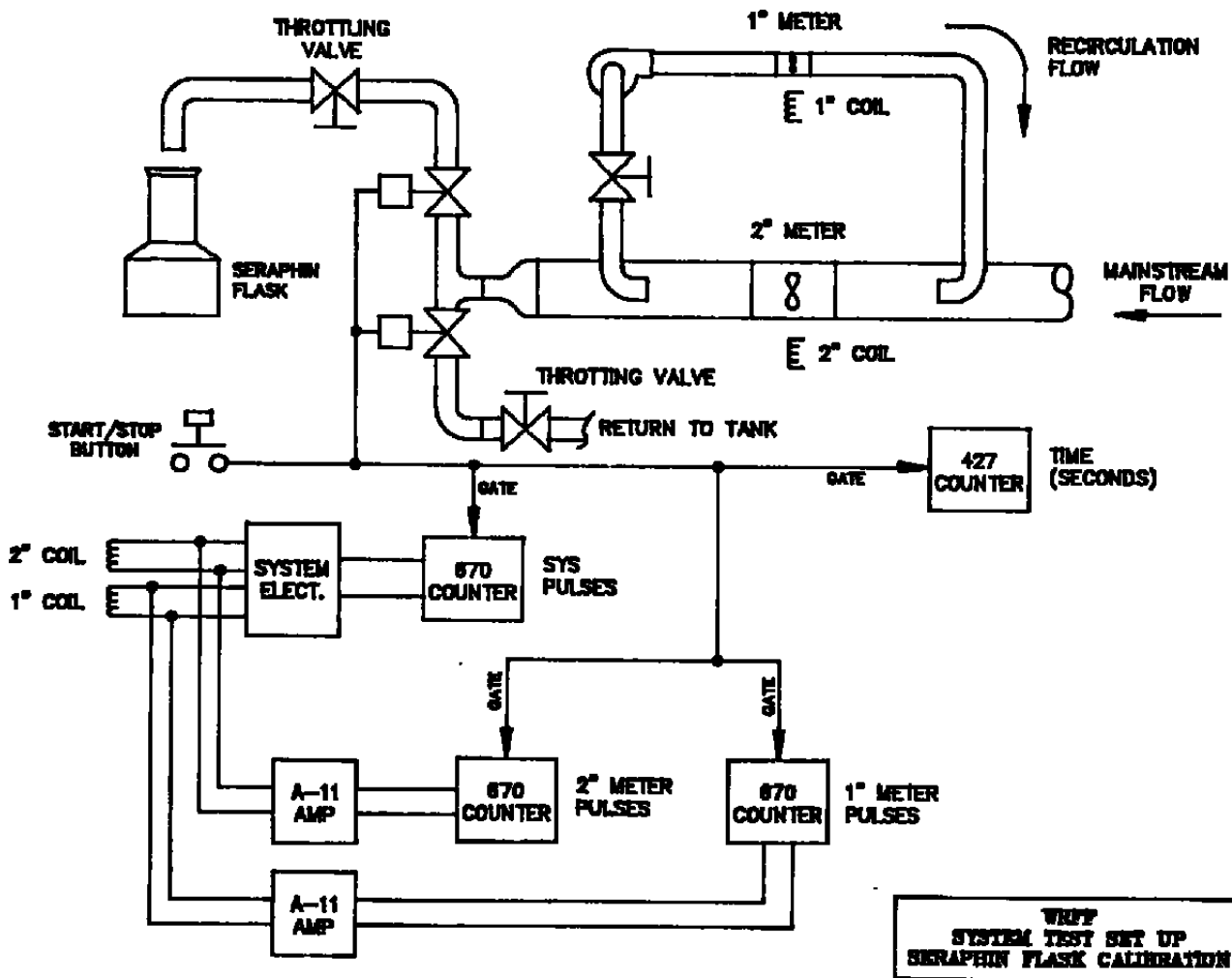

DATE 12/01/87

108935

PAGE 9 OF 11

TEST PROCEDURE
WIDE RANGE FUEL FLOWMETER

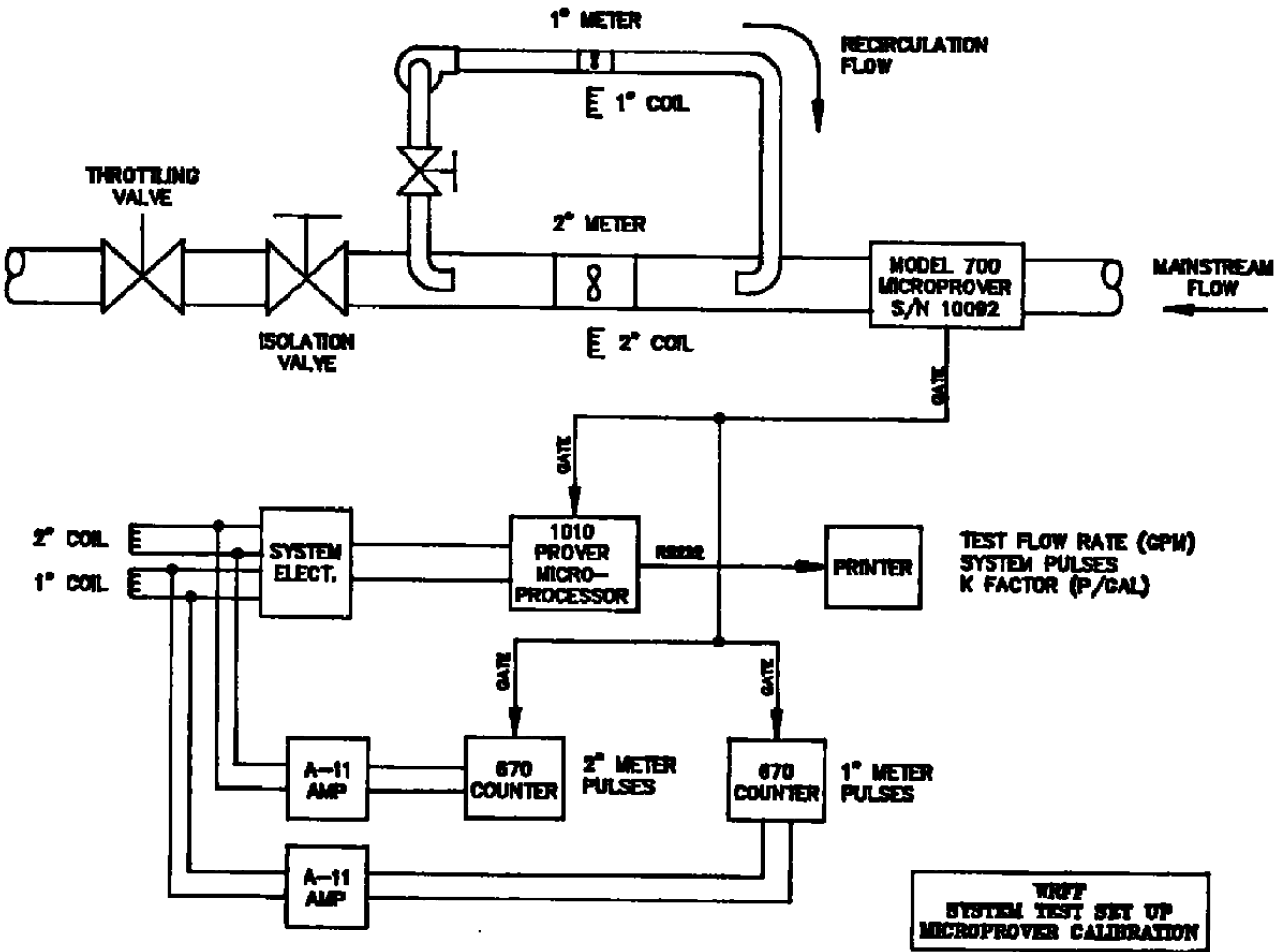

DATE 12/01/87

108935 PAGE 10 of 11

WIDE RANGE FUEL FLOWMETER

TEST PROCEDURE
WIDE RANGE FUEL FLOWMETER

SYSTEM CALIBRATION

DATE: _____

TEST NO: _____

DATE 12/01/87

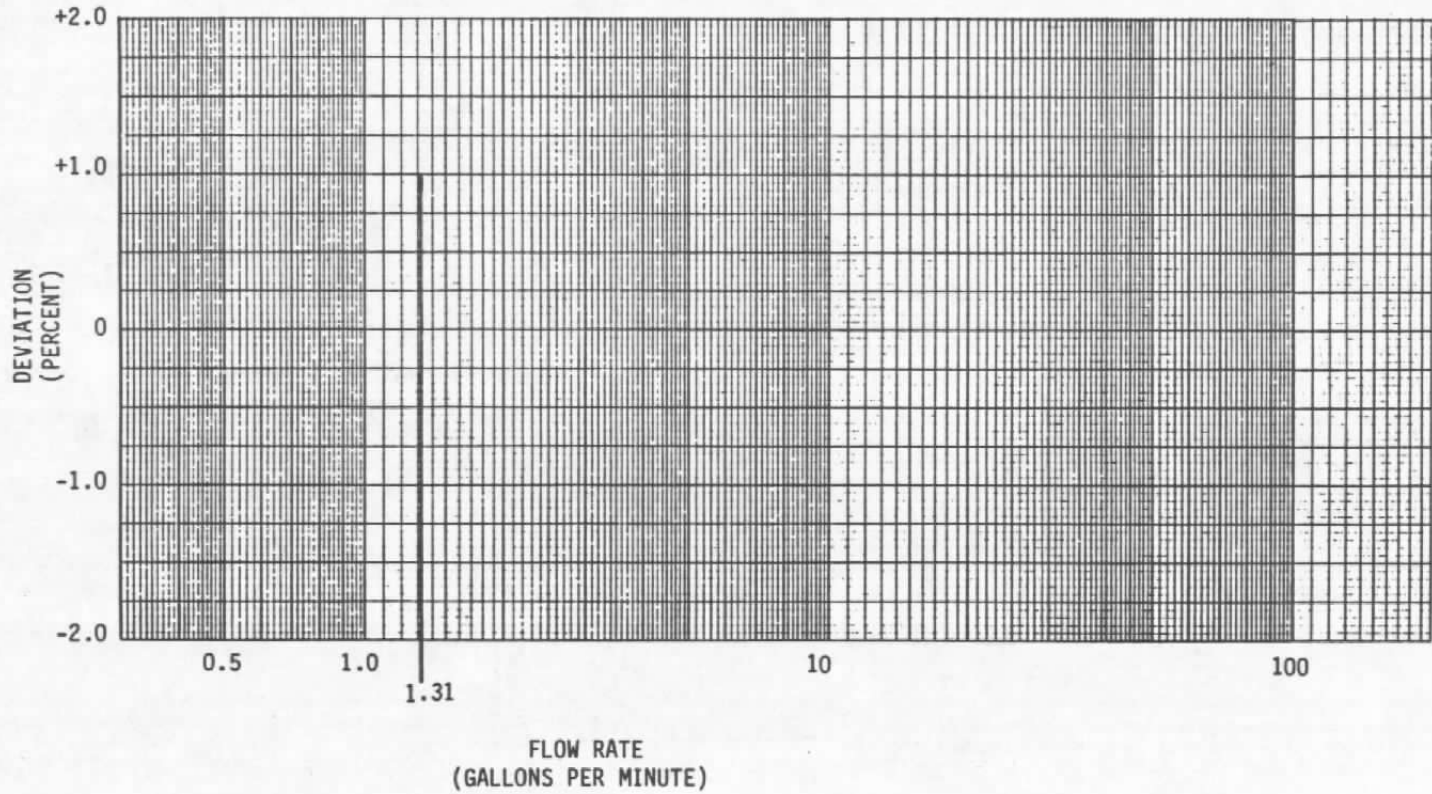

APPENDIX B

**TEST DATA AND CALCULATIONS
WIDE RANGE FUEL FLOWMETER**

WIDE RANGE FUEL FLOWMETER
 CALIBRATION DATA SHEET NO. 3
 MAINSTREAM METER CALIBRATION

DATE: 1-14-88

TIME - START: 3:40

AMB. TEMP. - START: 78 °F

STOP: 4:42

- STOP: 75 °F

TEST NO.: 88-9

PROVER TEST VOLUME = 24.724 GAL.

(1) TEST FLOW RATE (GPM), Ps, & "K" FACTOR-1010 COMPUTER PRINT OUT

NOM. FLOW RATE (REF)	PULSES		WATER TEMP. °F	K FACTOR (PULSES/GAL)	CALC % DEV.	CALCULATED TIME (SEC.)
	2"	1"				
20	11757	00	77	475.88	+ .26	61.552
40	11766	00	77	476.24	+ .33	41.241
60	11761	00	77	476.13	+ .31	24.572
80	11757	00	77	475.87	+ .25	19.063
100	11750	00	77	475.55	+ .18	14.736
120	11738	00	77	475.16	+ .11	12.595
140	11735	00	78	475.00	+ .07	10.695
160	11731	00	78	474.80	+ .03	9.400
180	11728	00	78	474.72	+ .01	8.214
200	11725	00	79	474.66	-0-	7.459

(2)

$$\% \text{ DEV.} = \left[\frac{K_{\text{(TEST)}} - K_{\text{(200)}}}{K_{\text{(200)}}} \right] \times 100$$

NOTES:

BY: M. W. Webb

APPROVED: H. L. Lister

Date 12/01/87
 REV1-8-88 (1) DELETED-TIME(SEC)
 (2) ADDED CALC. TIME

108935 Page 6 of 11

FIGURE B.1. MAINSTREAM METER CALIBRATION. (1 of 4)

***** TURBINE METER TEST REPORT *****

14 JAN 88 15:40

METER ID: WRFF

DATA BY: _____

TEST No. 88-9 PAGE 1 OF 3

***** CALIBRATION DATA *****

	RUN	RUN
METER DATA	2	1
COUNTS -----	11724.91	11727.81
METER FACTOR --	474.60229	474.71972
NEW METER FACTOR:	474.66113	

9. DEV = 0 -

PROVER DATA		
FLOW RATE	198.88	198.84

	RUN	RUN
METER DATA	2	1
COUNTS -----	11728.12	11727.50
METER FACTOR --	474.73217	474.70727
NEW METER FACTOR:	474.71972	

+ .01 %

PROVER DATA		
FLOW RATE	180.60	180.74

	RUN	RUN
METER DATA	2	1
COUNTS -----	11732.20	11730.66
METER FACTOR --	474.89746	474.83496
NEW METER FACTOR:	474.86621	

PROVER DATA		
FLOW RATE	158.28	158.76

	RUN	RUN
METER DATA	2	1
COUNTS -----	11730.97	11728.52
METER FACTOR --	474.84765	474.74853
NEW METER FACTOR:	474.79809	

+ .03 %

PROVER DATA		
FLOW RATE	157.81	158.24

	RUN	RUN
METER DATA	2	1
COUNTS -----	11734.89	11734.41
METER FACTOR --	475.00634	474.98681
NEW METER FACTOR:	474.99658	

+ .07 %

PROVER DATA		
FLOW RATE	138.70	138.93

***** TURBINE METER TEST REPORT *****

FIGURE B.1 MAINSTREAM METER CALIBRATION. (2 of 4)

***** CALIBRATION DATA *****

	RUN	RUN
METER DATA	2	1
COUNTS -----	11738.64	11739.56
METER FACTOR --	475.15820	475.19531
NEW METER FACTOR:	475.17675	

+ .11%

PROVER DATA		
FLOW RATE	117.78	118.87

	RUN	RUN
METER DATA	2	1
COUNTS -----	11750.67	11745.82
METER FACTOR --	475.64501	475.44897
NEW METER FACTOR:	475.54711	

+ .18%

PROVER DATA		
FLOW RATE	100.67	100.79

METER DATA		
COUNTS -----		
METER FACTOR --		
NEW METER FACTOR:	475.54711	

PROVER DATA		
FLOW RATE		

	RUN	RUN
METER DATA	2	1
COUNTS -----	11756.40	11756.10
METER FACTOR --	475.87695	475.86474
NEW METER FACTOR:	475.87084	

+ .25%

PROVER DATA		
FLOW RATE	77.81	78.40

	RUN	RUN
METER DATA	2	1
COUNTS -----	11761.38	11763.90
METER FACTOR --	476.07861	476.18066
NEW METER FACTOR:	476.12963	

+ .31%

PROVER DATA		
FLOW RATE	60.37	60.38

***** TURBINE METER TEST REPORT *****

14 JAN 88 16:23
METER ID: WRFF

DATA BY: _____

TEST No. 88-9 PAGE 2 of 3

***** CALIBRATION DATA *****

FIGURE B.1 MAINSTREAM METER CALIBRATION. (3 of 4)

	RUN	RUN
METER DATA	2	1
COUNTS -----	11766.59	11764.05
METER FACTOR --	476.28955	476.18676
NEW METER FACTOR:	476.23828	

+ .33 %

PROVER DATA		
FLOW RATE	35.97	37.35

	RUN
METER DATA	1
COUNTS -----	11758.49
METER FACTOR --	475.96142
NEW METER FACTOR:	475.96142

PROVER DATA	
FLOW RATE	19.94

***** TURBINE METER TEST REPORT *****

14 JAN 88 16:31

METER ID: WRFF

DATA BY: _____

TEST No. 88-9 PAGE 3 of 3

***** CALIBRATION DATA *****

METER DATA	
COUNTS -----	
METER FACTOR --	
NEW METER FACTOR:	476.23828

PROVER DATA	
FLOW RATE	

	RUN	RUN
METER DATA	2	1
COUNTS -----	11757.88	11754.91
METER FACTOR --	475.93701	475.81640
NEW METER FACTOR:	475.87670	

+ .26 %

PROVER DATA		
FLOW RATE	21.96	21.98

FIGURE B.1 MAINSTREAM METER CALIBRATION. (4 of 4)

WIDE RANGE FUEL FLOWMETER
 CALCULATION SHEET - % DEVIATION

DATE: 1-18-88

TEST NO.: 88-10 & 88-11

NOM. FLOW RATE (REF)	TEST FLOW RATE (GPM)	K FACTOR (PULSES/GAL)	% DEV.
.5	.484	466.91	-1.65
.5	.483	467.27	-1.57
1.0	.943	470.12	-.97
1.0	.943	470.72	-.84
2.0	2.105	472.35	-.50
2.0	2.110	470.80	-.83
2.0	2.094	472.50	-.47
4.0	4.106	471.50	-.68
4.0	4.103	472.40	-.49
8.0	8.49	472.54	-.46
15.0	16.40	472.85	-.39
30.0	30.50	474.61	-.02
60.0	60.71	474.75	+ .01
120.0	123.06	475.31	+ .12
180.0	179.43	474.72	-0-

% DEV. CALCULATED AS FOLLOWS:

$$\% \text{ DEV.} = \frac{\left[\frac{K}{(\text{TEST})} - \frac{K}{(180 \text{ GPM})} \right] \times 100}{K (180 \text{ GPM})}$$

BY: W Seiler
 APPROVED: W Seiler

WIDE RANGE FUEL FLOWMETER
 CALIBRATION DATA SHEET NO. 1
 SERAPHIN FLASK CALIBRATION

DATE: 1-18-88

TIME-START: 9:17

AMB. TEMP. START: 52 °F

STOP: 10:35

STOP: 56 °F

TEST NO: 88-10

RECORDED DATA

NOM FLOW RATE (GPM)	TIME (SEC)	VOLUME (GAL)	+/-IN	PULSES			WATER TEMP (F)	SYS. PRESS (PSI)
				2"	1"	SYS		
.5	247.79	1.9982	+ .50	48458	137912	934	55	58
.5	248.48	1.9982	+ .65	48605	138333	935		
1.0	318.36	5.0003	+1.10	63347	177001	2353	55	58
1.0	318.41	5.0003	+1.10	63363	177031	2356		
2.0	284.88	9.9955	- .70	59304	158400	4720	58	58
2.0	284.16	9.9955	- .90	59147	157991	4704		
4.0	146.00	9.9955	- .90	32661	81104	4711	61	58
4.0	146.07	9.9955	-1.40	32673	81119	4719		

CALCULATED

NOM. FLOW RATE (REF.)	TEST VOLUME (GAL)	TEST FLOW RATE (GPM)	K-FACTOR (PULSES/GAL)
.5	2.0004	.484	466.91
.5	2.0010	.483	467.27
1.0	5.0051	.943	470.12
1.0	5.0051	.943	470.72
2.0	9.9925	2.105	472.35
2.0	9.9916	2.110	470.80
4.0	9.9916	4.106	471.50
4.0	9.9894	4.103	472.40

DATA BY: M. Webb

APPROVED: H. Seiler

THIRD RUN CONDUCTED AT 2.0 GPM

286.32 SEC +.25in³ . 59563 159150 4721

9.9944 2.094 472.50 K FACTOR

1" FLOW STRAIGHTENER REMOVED PRIOR TO THIS RUN
 SYSTEM ZEROED BEFORE RUN

Date 12/02/87

108935 Page

4 of 11

FIGURE B.2. SYSTEM CALIBRATION. (2 of 5)

WIDE RANGE FUEL FLOWMETER
 CALIBRATION DATA SHEET NO. 2
 PROVER CALIBRATION

DATE: 1-18-88

TIME - START: 10:42
 STOP: 11:40

AMB. TEMP. START: 57°F
 STOP: 60°F

TEST NO.: 88-11

PROVER VOLUME: 24.724 GALLONS

RECORDED DATA

(1) TEST FLOW RATE (GPM), P_w, & K FACTOR-1010 COMPUTER PRINT OUT

NOM. FLOW RATE (GPM)	PULSES		WATER TEMP. (°F)	SYS. PRESS (PSI)	CALCULATED TIME (SEC.) (2)
	2"	1"			
8	45126	97069	59	58	174.728
15	29050	50403	59	58	90.454
30	21090	27183	59	56	48.637
60	16468	13750	58	48	24.435
120	14116	6892	58	54	17.055
180	13427	4926	58	46	8.268

NOTES: SYSTEM NOT REZEROED

DATA BY: M. de Wit
 APPROVED: H. Luder

Date 12/01/87
 REV1-8-88 (1) DELETED-TIME(SEC)
 (2) ADDED CALC. TIME

108935 Page 5 of 11

FIGURE B.2. SYSTEM CALIBRATION. (3 of 5)
 90

***** TURBINE METER TEST REPORT *****

18 JAN 88 11:05

METER ID: WRFP

DATA BY: _____

TEST No. 88-11 PAGE 1 OF 2

***** CALIBRATION DATA *****

	RUN	RUN	RUN
METER DATA	3	2	1
COUNTS -----	11676.65	11671.41	11678.70
METER FACTOR --	472.64868	472.43652	472.73193
NEW METER FACTOR:	472.54272		

PROVER DATA			
FLOW RATE	8.49	8.51	8.52

	RUN	RUN
METER DATA	2	1
COUNTS -----	11680.90	11682.52
METER FACTOR --	472.82080	472.88647
NEW METER FACTOR:	472.85375	

PROVER DATA		
FLOW RATE	16.40	16.18

	RUN	RUN
METER DATA	2	1
COUNTS -----	11722.51	11727.44
METER FACTOR --	474.50537	474.70507
NEW METER FACTOR:	474.60522	

PROVER DATA		
FLOW RATE	30.50	30.47

	RUN	RUN
METER DATA	2	1
COUNTS -----	11729.81	11727.10
METER FACTOR --	474.80078	474.69091
NEW METER FACTOR:	474.74584	

PROVER DATA		
FLOW RATE	60.71	60.69

	RUN	RUN
METER DATA	2	1
COUNTS -----	11741.41	11743.32
METER FACTOR --	475.27026	475.34765
NEW METER FACTOR:	475.30908	

PROVER DATA		
FLOW RATE	123.06	122.94

FIGURE B.2. SYSTEM CALIBRATION. (4 of 5)

18 JAN 88 11:34
METER ID: WRFF

TIME 5 4 -----

***** CALIBRATION DATA *****

METER DATA	RUN 2	RUN 1
COUNTS	11728.88	11726.55
METER FACTOR	474.76293	474.66894
NEW METER FACTOR:	474.71606	

PROVER DATA		
FLOW RATE	179.48	179.52

TEST No. 88-11 PAGE 2 OF 2

FIGURE B.2. SYSTEM CALIBRATION. (5 of 5)

WIDE RANGE FUEL FLOWMETER
 CALCULATION SHEET - % DEVIATION

DATE: 1-19-88

TEST NO.: 88-12 & 88-13
 LOW PRESSURE CALIBRATION

NOM. FLOW RATE (REF)	TEST FLOW RATE (GPM)	K FACTOR (PULSES/GAL)	% DEV.
.5	.430	470.91	-.80
.5	.534	474.67	-.01
1.0	.997	475.12	+.08
1.0	.998	476.57	+.39
2.0	2.038	473.47	-.26
2.0	2.039	473.57	-.24
4.0	3.928	473.59	-.24
4.0	3.918	473.68	-.22
8.0	6.96	473.82	-.19
15.0	13.46	473.02	-.36
30.0	31.21	474.81	+.02
60.0	58.30	474.72	-0-
120.0	124.12	475.20	+.10
180.0	176.63	474.62	-.02
		474.72	-0-

% DEV. CALCULATED AS FOLLOWS:

$$\% \text{ DEV.} = \frac{K_{(\text{TEST})} - K_{(180 \text{ GPM})}}{K_{(180 \text{ GPM})}} \times 100$$

BY: M. W. Webb
 APPROVED: H. Seiler

Date 12/01/87

108935 Page 7 of 11

FIGURE B.3. LOW PRESSURE CALIBRATION. (1 of 5)

WIDE RANGE FUEL FLOWMETER
 CALIBRATION DATA SHEET NO. 1
 SERAPHIN FLASK CALIBRATION

DATE: 1-19-88

TIME-START: 9:40

AMB. TEMP. START: 50° F

STOP: 10:53

STOP: 55° F

TEST NO: 88-12

RECORDED DATA

NOM FLOW RATE (GPM)	TIME (SEC)	VOLUME (GAL)	+/-IN ³	PULSES			WATER TEMP (F)	SYS. PRESS (PSI)
				2"	1"	SYS		
.5	279.82	1.9982	+ .50	54823	156243	942	55	20
.5	224.81	1.9982	+ .75	44227	125493	950		
1.0	301.18	5.0003	+ 1.10	60338	168072	2378	57	19
1.0	300.76	5.0003	- 0 -	60271	167864	2383		
2.0	294.29	9.9955	- .30	61389	164294	4732	58	19
2.0	294.08	9.9955	- .25	61365	164222	4733		
4.0	153.03	9.9955	+ 5.00	34218	85470	4744	67	18
4.0	152.78	9.9955	- 4.20	34156	85340	4726		

CALCULATED

NOM. FLOW RATE (REF.)	TEST VOLUME (GAL)	TEST FLOW RATE (GPM)	K-FACTOR (PULSES/GAL)
.5	2.0004	.430	470.91
.5	2.0014	.534	474.67
1.0	5.0051	.997	475.12
1.0	5.0003	.998	476.57
2.0	9.9942	2.038	473.47
2.0	9.9944	2.039	473.57
4.0	10.0171	3.928	473.59
4.0	9.9773	3.918	473.68

DATA BY: M. Webb

APPROVED: H. Seiler

UNIT ZEROED BEFORE TEST
 LOW PRESSURE CALIBRATION

WIDE RANGE FUEL FLOWMETER

CALIBRATION DATA SHEET NO. 2

PROVER CALIBRATION

DATE: 1-19-88TIME - START: 12:45AMB. TEMP. START: 56°FSTOP: 1:37STOP: 66°FTEST NO.: 88-13PROVER VOLUME: 24.724 GALLONSRECORDED DATA

(1) TEST FLOW RATE (GPM), Ps, & K FACTOR-1010 COMPUTER PRINT OUT

NOM. FLOW RATE (GPM)	PULSES		WATER TEMP. (°F)	SYS. PRESS (PSI)	CALCULATED TIME (SEC.) (2)
	2"	1"			
8	52665	118772	68	25	213.138
15	32920	61575	68	25	110.211
30	20928	26671	66	20	47.531
60	16681	14365	65	20	23.445
120	14110	6873	65	20	11.952
180	13451	5024	65	17	8.399

NOTES:

LOW PRESSURE CALIBRATION
UNIT NOT REZEROED

DATA BY: Milo WoltAPPROVED: H. Lewis

Date 12/01/87

108935 Page

5 of 11

REV1-8-88 (1) DELETED-TIME(SEC)
(2) ADDED CALC. TIME

FIGURE B.3. LOW PRESSURE CALIBRATION. (3 of 5)

19 JAN 88 12:53
 METER ID: WRFF
 TEST NO. 88-13 LOW PRESSURE CALIB. PAGE 1 OF 2

	RUN	RUN
METER DATA	2	1
COUNTS	11686.30	11685.24
METER FACTOR	473.03930	472.99658
NEW METER FACTOR:	473.01806	

PROVER DATA		
FLOW RATE	13.46	13.59

	RUN	RUN
METER DATA	2	1
COUNTS	11707.01	11704.40
METER FACTOR	473.87768	473.77197
NEW METER FACTOR:	473.82495	

PROVER DATA		
FLOW RATE	6.96	7.05

METER DATA
 COUNTS
 METER FACTOR
 NEW METER FACTOR: 473.82495

PROVER DATA
 FLOW RATE

	RUN	RUN
METER DATA	2	1
COUNTS	11731.05	11729.07
METER FACTOR	474.85083	474.77050
NEW METER FACTOR:	474.81079	

PROVER DATA		
FLOW RATE	31.21	31.09

	RUN	RUN
METER DATA	2	1
COUNTS	11726.89	11728.55
METER FACTOR	474.68261	474.74975
NEW METER FACTOR:	474.71630	

PROVER DATA		
FLOW RATE	58.30	58.42

***** TURBINE METER TEST REPORT *****

FIGURE B.3. LOW PRESSURE CALIBRATION. (4 of 5)

19 JAN 88 13:24

METER ID: WRF

DATA BY: _____

TEST NO. 88-13 PAGE 2 OF 2

***** CALIBRATION DATA *****

	RUN	RUN
METER DATA	2	1
COUNTS -----	11739.62	11739.60
METER FACTOR --	475.19799	475.19726
NEW METER FACTOR:	475.19775	

PROVER DATA		
FLOW RATE	124.12	123.90

	RUN	RUN
METER DATA	2	1
COUNTS -----	11725.28	11725.30
METER FACTOR --	474.61743	474.61791
NEW METER FACTOR:	474.61767	

PROVER DATA		
FLOW RATE	176.63	176.15

FIGURE B.3. LOW PRESSURE CALIBRATION. (5 of 5)

WIDE RANGE FUEL FLOWMETER
 CALCULATION SHEET - % DEVIATION

DATE: 1-21-88

TEST NO.: 88-17 & 88-18

NOM. FLOW RATE (REF)	TEST FLOW RATE (GPM)	K FACTOR (PULSES/GAL)	% DEV.
.5	.539	460.417	-3.01
.5	.534	461.416	-2.80
1.0	1.047	468.262	-1.36
1.0	1.048	465.273	-1.99
2.0	2.098	471.357	-.71
2.0	2.091	469.635	-1.07
4.0	4.065	471.505	-.68
4.0	4.067	471.753	-.63
8.0	7.43	472.53	-.46
15.0	16.88	472.62	-.44
30.0	28.98	474.25	-.10
60.0	60.11	474.27	-.09
120.0	119.82	474.88	+.03
180.0	179.20	474.64	-.02
		474.72	-0-

% DEV. CALCULATED AS FOLLOWS:

$$\% \text{ DEV.} = \frac{\left[\frac{K_{(\text{TEST})} - K_{(180 \text{ GPM})}}{K_{(180 \text{ GPM})}} \right] \times 100}{K_{(180 \text{ GPM})}}$$

BY: MS

APPROVED: H Seiler

Date 12/01/87

108935 Page

7 of 11

FIGURE B.4. STABILITY CALIBRATION. NO. 1 (1 of 5)

**WIDE RANGE FUEL FLOWMETER
CALIBRATION DATA SHEET NO. 1
SERAPHIN FLASK CALIBRATION**

DATE: 1-21-88

TIME-START: 7:50

AMB. TEMP. START: 44°F

STOP: 11:00

STOP: 62°F

TEST NO: BA-17

RECORDED DATA

NOM FLOW RATE (GPM)	TIME (SEC)	VOLUME (GAL)	+/-IN	PULSES			WATER TEMP (F)	SYS. PRESS (PSI)
				2"	1"	SYS		
.5	222.50	1.9982	+ .50	43717	123865	921	55	58
.5	223.90	1.9982	- .50	43949	124541	921		
1.0	286.65	5.0003	+ .27	57392	159335	2342	55	58
1.0	286.15	5.0003	- .25	57262	159004	2326		
2.0	286.03	9.9955	+ 1.23	39563	138752	4714	63	58
2.0	286.64	9.9955	- 1.10	39685	139113	4712		
4.0	146.88	9.9955	- 10.25	32865	81542	4692	64	58
4.0	146.53	9.9955	- 14.40	32795	81357	4686		

CALCULATED

NOM. FLOW RATE (REF.)	TEST VOLUME (GAL)	TEST FLOW RATE (GPM)	K-FACTOR (PULSES/GAL)
.5	2.00036	.539	460.417
.5	1.99803	.534	461.416
1.0	5.00147	1.047	468.262
1.0	4.99922	1.048	468.273
2.0	10.00091	2.098	471.357
2.0	9.99673	2.091	469.635
4.0	9.95112	4.065	471.505
4.0	9.93316	4.067	471.753

DATA BY: Mike Webb

APPROVED: W. Siler

UNIT NOT ZEROED BEFORE RUN
LAST ZERO 3:30 PM 1-20-88

FIGURE B.4. STABILITY CALIBRATION. NO. 1 (2 of 5)

WIDE RANGE FUEL FLOWMETER
 CALIBRATION DATA SHEET NO. 2

PROVER CALIBRATION

DATE: 1-21-88

TIME - START: 2:40
 STOP: 3:54

AMB. TEMP. START: 71°F
 STOP: 70°F

TEST NO.: 88-18

PROVER VOLUME: 24.724 GALLONS

RECORDED DATA

TEST FLOW RATE (GPM), Ps, & K FACTOR-1010 COMPUTER PRINT OUT

NOM. FLOW RATE (GPM)	PULSES		WATER TEMP. (°F)	SYS. PRESS (PSI)	CALCULATED TIME (SEC.)
	2"	1"			
8	45169	96951	73	58	199.655
15	28645	49112	73	58	87.532
30	21624	28683	70	54	51.188
60	16531	13938	70	49	24.679
120	14155	7102	70	54	12.381
180	13440	4963	70	43	8.278

NOTES: NOT REZEROED PRIOR TO RUN

DATA BY: M. J. 55

APPROVED: W. L. L. L.

Date 12/01/87

108935 Page 5 of 11

FIGURE B.4. STABILITY CALIBRATION. NO. 1 (3 of 5)

***** CALIBRATION DATA *****

RUN
METER DATA 1
COUNTS ----- 11675.45
METER FACTOR -- 472.60034
NEW METER FACTOR: 472.60034

PROVER DATA
FLOW RATE 7.07

***** TURBINE METER TEST REPORT *****

21 JAN 88 14:47
METER ID: WRFF DATA BY: _____

***** CALIBRATION DATA *****

RUN
METER DATA 1
COUNTS ----- 11655.36
METER FACTOR -- 471.78710
NEW METER FACTOR: 471.78710

PROVER DATA
FLOW RATE 8.23

***** TURBINE METER TEST REPORT *****

21 JAN 88 15:02
METER ID: WRFF DATA BY: _____

TEST No. 88-18 PAGE 1 OF 2

***** CALIBRATION DATA *****

	RUN	RUN	RUN
METER DATA	3	2	1
COUNTS -----	11671.10	11676.28	11663.12
METER FACTOR --	472.42407	472.63403	472.10107
NEW METER FACTOR:	472.52905		

PROVER DATA	7.43	7.59	7.84
FLOW RATE			

	RUN	RUN
METER DATA	2	1
COUNTS -----	11676.92	11675.10
METER FACTOR --	472.65991	472.58593
NEW METER FACTOR:	472.62304	

PROVER DATA	16.88	16.68
FLOW RATE		

FIGURE B. 4. STABILITY CALIBRATION. NO. 1 (4 of 5)

	RUN	RUN
METER DATA	2	1
COUNTS -----	11713.94	11718.58
METER FACTOR --	474.15844	474.34643
NEW METER FACTOR:	474.25244	

PROVER DATA		
FLOW RATE	28.98	30.09

	RUN	RUN
METER DATA	2	1
COUNTS -----	11714.82	11718.44
METER FACTOR --	474.19384	474.34057
NEW METER FACTOR:	474.26733	

PROVER DATA		
FLOW RATE	60.11	60.15

	RUN	RUN
METER DATA	2	1
COUNTS -----	11731.63	11731.72
METER FACTOR --	474.87451	474.87817
NEW METER FACTOR:	474.87646	

PROVER DATA		
FLOW RATE	119.82	119.95

***** TURBINE METER TEST REPORT *****

21 JAN 88 15:37

METER ID: WRFF

DATA BY: _____

TEST No. 88-18 PAGE 2 OF 2

***** CALIBRATION DATA *****

	RUN	RUN	RUN
METER DATA	3	2	1
COUNTS -----	11727.13	11726.91	11720.35
METER FACTOR --	474.69213	474.68334	474.41796
NEW METER FACTOR:	474.68774		

PROVER DATA			
FLOW RATE	153.56	181.30	181.57

	RUN	RUN
METER DATA	2	1
COUNTS -----	11725.81	11725.92
METER FACTOR --	474.63867	474.64331
NEW METER FACTOR:	474.64111	

PROVER DATA		
FLOW RATE	179.20	179.51

FIGURE B.5. STABILITY CALIBRATION NO 1 (5 of 5)

WIDE RANGE FUEL FLOWMETER
 CALCULATION SHEET - % DEVIATION

DATE: 1-22-88

TEST NO.: 88-19 & 88-20

NOM. FLOW RATE (REF)	TEST FLOW RATE (GPM)	K FACTOR (PULSES/GAL)	% DEV.
.5	.513	462.81	-2.51
.5	.514	458.30	-3.46
1.0	.938	470.96	-.79
1.0	.938	470.16	-.96
2.0	2.042	472.55	-.46
2.0	2.031	471.28	-.72
4.0	4.142	472.52	-.46
4.0	4.060	471.95	-.58
8.0	8.85	471.83	-.61
15.0	15.04	472.14	-.54
30.0	32.15	474.22	-.11
60.0	61.58	474.31	-.09
120.0	123.02	474.93	+.04
180.0	180.42	474.44	-.06
		474.72	-0-

% DEV. CALCULATED AS FOLLOWS:

$$\% \text{ DEV.} = \frac{\left[\frac{K_{(\text{TEST})} - K_{(180 \text{ GPM})}}{K_{(180 \text{ GPM})}} \right] \times 100}{K_{(180 \text{ GPM})}}$$

BY: ML

APPROVED: W. L. L. L.

FIGURE B.5. STABILITY CALIBRATION NO. 2 (1 of 5)

WIDE RANGE FUEL FLOWMETER
 CALIBRATION DATA SHEET NO. 1
 SERAPHIN FLASK CALIBRATION

DATE: 1-21-88

TIME-START: 3:55

AMB. TEMP. START: 70°F

STOP: 11:47 AM 1-22-88

STOP: 63°F

TEST NO: 88-19

RECORDED DATA

NOM FLOW RATE (GPM)	TIME (SEC)	VOLUME (GAL)	+/-IN	PULSES			WATER TEMP (F)	SYS. PRESS (PSI)
				2"	1"	SYS		
.5	233.84	1.9982	+ .60	45919	130224	926	72	58
.5	233.09	1.9982	- .40	45767	129120	915		
1.0	319.96	5.0003	+ .50	63858	178015	2356	65	58
1.0	320.27	5.0003	+1.50	63903	178144	2354		
2.0	293.73	9.9955	+ .80	61163	163350	4725	69	58
2.0	295.54	9.9955	+2.10	61600	164644	4715		
4.0	143.84	9.9955	-15.20	32383	80148	4692	73	59
4.0	146.92	9.9955	-12.40	32430	80286	4692		

CALCULATED

NOM. FLOW RATE (REF.)	TEST VOLUME (GAL)	TEST FLOW RATE (GPM)	K-FACTOR (PULSES/GAL)
.5	2.0008	.513	462.81
.5	1.9965	.514	458.30
1.0	5.0025	.938	470.96
1.0	5.0068	.938	470.16
2.0	9.9990	2.042	472.55
2.0	10.0046	2.031	471.28
4.0	9.9299	4.142	472.52
4.0	9.9418	4.060	471.95

DATA BY: M. Webb

APPROVED: H. Selzer

NOTE: TEST WAS STARTED 3:55 PM ON 1-21-88
 TEST STAND PROBLEMS FORCED CESSATION OF TEST APPROX 5:00 PM
 TEST RESUMED 11:00 AM 1-22-88
 COMPLETED 11:47 AM 1-22-88

NOT REZEROED PRIOR TO RUN - LAST ZERO 1-20-8

Date 12/02/87

108935 Page 4 of 11

FIGURE B.5. STABILITY CALIBRATION NO. 2 (2 of 5)

WIDE RANGE FUEL FLOWMETER

CALIBRATION DATA SHEET NO. 2

PROVER CALIBRATION

DATE: 1-22-88TIME - START: 12:53AMB. TEMP. START: 65° FSTOP: 2:05STOP: 66° FTEST NO.: 88-20PROVER VOLUME: 24.724 GALLONSRECORDED DATA

(1) TEST FLOW RATE (GPM), Ps, & K FACTOR-1010 COMPUTER PRINT OUT

NOM. FLOW RATE (GPM)	PULSES		WATER TEMP. (° F)	SYS. PRESS (PSI)	CALCULATED TIME (SEC.) (2)
	2"	1"			
8	43993	93599	70	58	167.620
15	30707	55109	70	56	98.633
30	20661	25874	70	55	46.141
60	16423	13622	70	54	24.090
120	14127	6929	70	53	12.059
180	13426	4933	70	45	8.222

NOTES: NOT REZEROED PRIOR TO RUNDATA BY: M. WoltAPPROVED: W. Seiler

Date 12/01/87

108935 Page

5 of 11

REVI-8-88 (1) DELETED-TIME(SEC)
(2) ADDED CALC. TIME

FIGURE B.5. STABILITY CALIBRATION NO. 2 (3 of 5)

	RUN 2	RUN 1
METER DATA		
COUNTS -----	11654.79	11658.02
METER FACTOR --	471.76391	471.89477
NEW METER FACTOR:	471.82934	

PROVER DATA
FLOW RATE 8.85 8.82

	RUN 2	RUN 1
METER DATA		
COUNTS -----	11680.86	11674.19
METER FACTOR --	472.81933	472.54931
NEW METER FACTOR:	472.81933	

PROVER DATA
FLOW RATE 17.71 17.46

***** TURBINE METER TEST REPORT *****

22 JAN 88 13:10

METER ID: WRFF

DATA BY: _____

TEST No. 88-20 PAGE 1 OF 2

***** CALIBRATION DATA *****

	RUN 1
METER DATA	
COUNTS -----	11658.44
METER FACTOR --	471.91186
NEW METER FACTOR:	471.91186

PROVER DATA
FLOW RATE 13.33

	RUN 1
METER DATA	
COUNTS -----	11666.37
METER FACTOR --	472.23291
NEW METER FACTOR:	472.23291

PROVER DATA
FLOW RATE 15.17

	RUN 5	RUN 4	RUN 3	RUN 2	RUN 1
METER DATA					
COUNTS -----	11666.84	11661.45	11671.96	11664.32	11676.89
METER FACTOR --	472.25195	472.03344	472.45898	472.14965	472.65869
NEW METER FACTOR:	472.14282				

PROVER DATA
FLOW RATE 15.04 15.06 15.08 15.10 15.12

FIGURE B.5. STABILITY CALIBRATION NO.2 (4 of 5)

	RUN	RUN
METER DATA	2	1
COUNTS -----	11715.42	11715.40
METER FACTOR --	474.21826	474.21728
NEW METER FACTOR:	474.21777	

PROVER DATA		
FLOW RATE	32.15	31.87

	RUN	RUN
METER DATA	2	1
COUNTS -----	11716.62	11718.57
METER FACTOR --	474.26684	474.34594
NEW METER FACTOR:	474.30639	

PROVER DATA		
FLOW RATE	61.58	61.36

***** TURBINE METER TEST REPORT *****

22 JAN 88 13:46

METER ID: WRFF

DATA BY: _____

TEST No. 88-20 PAGE 2 OF 2

***** CALIBRATION DATA *****

	RUN	RUN
METER DATA	2	1
COUNTS -----	11733.98	11732.23
METER FACTOR --	474.96972	474.89868
NEW METER FACTOR:	474.93432	

PROVER DATA		
FLOW RATE	123.02	122.70

	RUN	RUN
METER DATA	2	1
COUNTS -----	11721.10	11720.46
METER FACTOR --	474.44824	474.42236
NEW METER FACTOR:	474.43530	

PROVER DATA		
FLOW RATE	180.42	180.35

FIGURE B. 5. STABILITY CALIBRATION NO. 2 (5 of 5)

WIDE RANGE FUEL FLOWMETER
 CALCULATION SHEET - % DEVIATION

DATE: 1-25-88

TEST NO.: 88-22 & 88-23 AIRMOTOR PUMP TEST

NOM. FLOW RATE (REF)	TEST FLOW RATE (GPM)	K FACTOR (PULSES/GAL)	% DEV.
.5	.531	473.67	-.22
.5	.532	470.62	-.86
1.0	1.089	466.59	-1.71
1.0	1.088	470.60	-.87
2.0	1.931	469.81	-1.03
2.0	1.929	472.62	-.44
4.0	4.030	471.41	-.70
4.0	4.026	472.77	-.41
8.0	9.21	472.41	-.49
15.0	17.69	472.77	-.41
30.0	33.41	472.61	-.44
60.0	63.57	473.14	-.33
120.0	123.33	473.77	-.20
180.0	182.95	474.28	-.09
		474.72	-0-

% DEV. CALCULATED AS FOLLOWS:

$$\% \text{ DEV.} = \frac{\left[\frac{K_{(\text{TEST})} - K_{(180 \text{ GPM})}}{K_{(180 \text{ GPM})}} \right] \times 100}{K_{(180 \text{ GPM})}}$$

BY: MS

APPROVED: W Seiler

WIDE RANGE FUEL FLOWMETER
 CALIBRATION DATA SHEET NO. 1
 SERAPHIN FLASK CALIBRATION AIRMOTOR PUMP

DATE: 1-25-88

TIME-START: 10:30

AMB. TEMP. START: 67°F

STOP: 11:28

STOP: 70°F

TEST NO: 88-22

RECORDED DATA

NOM FLOW RATE (GPM)	TIME (SEC)	VOLUME (GAL)	+/-IN ³	PULSES			WATER TEMP (F)	SYS. PRESS (PSI)
				2"	1"	8YS		
.5	225.62	1.9982	+2.5	43045	122007	947	77	58
.5	225.58	1.9982	+3.0	42269	119773	941		
1.0	274.67	5.0003	-3.50	51615	142845	2326	76	58
1.0	274.85	5.0003	-4.00	51932	143718	2345		
2.0	310.57	9.9955	-2.50	62431	167324	4695	77	58
2.0	310.57	9.9955	-2.5	63579	170585	4719		
4.0	748.00	9.9955	-12.75	32851	81629	4686	77	58
4.0	748.13	9.9955	-13.00	33074	82233	4699		

CALCULATED

NOM. FLOW RATE (REF.)	TEST VOLUME (GAL)	TEST FLOW RATE (GPM)	K-FACTOR (PULSES/GAL)
.5	1.9993	.531	473.67
.5	1.9995	.532	470.62
1.0	4.9851	1.087	466.59
1.0	4.9838	1.088	470.60
2.0	9.9933	1.931	469.81
2.0	9.9847	1.929	472.62
4.0	9.9403	4.030	471.41
4.0	9.9392	4.026	472.77

DATA BY: M. Webb

APPROVED: H. Seiler

RESET BEFORE RUN

* ICE BUILD UP NOTED ON AIR MOTOR DISCHARGE MUFFLER. DEFROSTED BEFORE NEXT RUN.

AIR PRESSURE

.5 GPM	66 PSI
.5	64 "
1.0	65 "
1.0	65 "
2.0	65 "
2.0	64 "
4.0	65 "
4.0	66 "

Date 12/02/87

108935 Page 4 of 11

FIGURE B.6. AIRMOTOR SYSTEM CALIBRATION. (2 of 6)

WIDE RANGE FUEL FLOWMETER

CALIBRATION DATA SHEET NO. 2

PROVER CALIBRATION AIR MOTOR PUMP

DATE: 1-25-88

TIME - START: 11:31

AMB. TEMP. START: 70°F

STOP: 1:50

STOP: 73°F

TEST NO.: 88-23

PROVER VOLUME: 24.724 GALLONS

RECORDED DATA

(1) TEST FLOW RATE (GPM), Ps, & K FACTOR-1010 COMPUTER PRINT OUT

NOM. FLOW RATE (GPM)	PULSES		WATER TEMP. (°F)	SYS. PRESS (PSI)	CALCULATED TIME (SEC.) (2)
	2"	1"			
8	43089	91417	75	56	161.068
15	29211	51013	77	56	91.401
30	20204	29716	76	54	44.401
60	14167	12976	76	48	23.836
120	14084	6891	76	54	12.028
180	13379	4820	76	45	8.108

AIR PRESSURE

NOTES: NOT REZEROED BEFORE RUN

8 GPM	65 Psi
15	67
30	66
60	66
120	67
180	67

DATA BY: M. J. Webb

APPROVED: H. Linder

REPEAT 8 GPM 42695 89918 76°F P=56 Psi AIR P=66 Psi
 15 GPM 27697 46424 77°F P=56 Psi AIR P=66 Psi

Date 12/01/87

108935 Page

5 of 11

REV1-8-88 (1) DELETED-TIME(SEC)
 (2) ADDED CALC. TIME

FIGURE B.6. AIRMOTOR SYSTEM CALIBRATION. (3 of 6)

	RUN	RUN
METER DATA	2	1
COUNTS -----	11544.96	11547.97
METER FACTOR --	467.31860	467.44018
NEW METER FACTOR:	467.37939	

PROVER DATA
 FLOW RATE 9.21 9.13

METER DATA
 COUNTS -----
 METER FACTOR --
 NEW METER FACTOR: 467.37939

PROVER DATA
 FLOW RATE

@+U/w***** TURBINE METER TEST REPORT *****

25 JAN 88 12:24
 METER ID: WRFF

DATA BY: _____

TEST No. 88-23 AIRMOTOR PUMP PAGE 1 OF 5

***** CALIBRATION DATA *****

METER DATA
 COUNTS -----
 METER FACTOR --
 NEW METER FACTOR: 467.37939

PROVER DATA
 FLOW RATE

>e+f***** TURBINE METER TEST REPORT *****

25 JAN 88 12:27
 METER ID: WRFF

DATA BY: _____

***** CALIBRATION DATA *****

METER DATA
 COUNTS -----
 METER FACTOR --
 NEW METER FACTOR: 467.37939

PROVER FLOW RATE INSTABILITY
 8 1/2 IS GPM FLOWS REPEATED
 AT END OF THIS RUN

JK

PROVER DATA
 FLOW RATE

-f***** TURBINE METER TEST REPORT *****

FIGURE B.6. AIRMOTOR SYSTEM CALIBRATION. (4 of 6)

***** CALIBRATION DATA *****

METER DATA	RUN 4	RUN 3	RUN 2	RUN 1
COUNTS -----	11609.11	11604.51	11613.78	11600.96
METER FACTOR --	469.91503	469.80957	470.10400	469.58520
NEW METER FACTOR:	469.86230			

PROVER DATA	RUN 4	RUN 3	RUN 2	RUN 1
FLOW RATE	16.23	16.28	16.34	16.55

METER DATA	RUN 2	RUN 1
COUNTS -----	11675.85	11675.34
METER FACTOR --	472.61669	472.59594
NEW METER FACTOR:	472.60644	

PROVER DATA	RUN 2	RUN 1
FLOW RATE	33.41	33.02

METER DATA	RUN 2	RUN 1
COUNTS -----	11688.43	11689.21
METER FACTOR --	473.12573	473.15747
NEW METER FACTOR:	473.14160	

PROVER DATA	RUN 2	RUN 1
FLOW RATE	63.57	63.08

METER DATA	RUN 2	RUN 1
COUNTS -----	11706.08	11702.54
METER FACTOR --	473.84008	473.69677
NEW METER FACTOR:	473.76855	

PROVER DATA	RUN 2	RUN 1
FLOW RATE	123.33	122.91

METER DATA	RUN 2	RUN 1
COUNTS -----	11715.57	11718.51
METER FACTOR --	474.22412	474.34326
NEW METER FACTOR:	474.28369	

PROVER DATA	RUN 2	RUN 1
FLOW RATE	182.95	182.13

***** TURBINE METER TEST REPORT *****

25 JAN 88 13:07
METER ID: WRFF

DATA BY: _____

TEST 88-23 PAGE 2 OF 3

***** CALIBRATION DATA *****

FIGURE B.6. AIRMOTOR SYSTEM CALIBRATION. (5 of 6)

	RUN	RUN
METER DATA	2	1
COUNTS -----	11667.79	11673.45
METER FACTOR --	472.29028	472.51953
NEW METER FACTOR:	472.40502	

PROVER DATA		
FLOW RATE	9.21	9.33

	RUN	RUN
METER DATA	2	1
COUNTS -----	11678.47	11680.94
METER FACTOR --	472.72241	472.82275
NEW METER FACTOR:	472.77270	

PROVER DATA		
FLOW RATE	17.69	17.44

25 JAN 88
TEST 88-23 PAGE 3 OF 3

FIGURE B.6. AIRMOTOR SYSTEM CALIBRATION. (6 of 6)