

FILE COPY

APPROVED FOR PUBLIC RELEASE
DISTRIBUTION UNLIMITED

REPORT NO. 89-R-09
AFPEA PROJECT NO. 88-P-102

1

AD-A211 523

DTIC
ELECTE

AUG 17 1989

C

D

3

D

Robbin L. Miller
Mechanical Engineer

AUTOVON 787-3362

Commercial (513) 257-3362

QUALIFICATION TESTING OF THE COMBAT TALON II
SIGNAL DATA CONVERTER CONTAINER

HQ AFLC/DSTZ
AIR FORCE PACKAGING EVALUATION ACTIVITY
Wright-Patterson AFB OH 45433-5999

August 1989

89 8 17 105

TABLE OF CONTENTS

	<u>Page</u>
ABSTRACT.....	i
TABLE OF CONTENTS.....	ii
INTRODUCTION	
BACKGROUND.....	1
PURPOSE.....	1
DESCRIPTION OF TEST CONTAINER.....	1
TEST OUTLINE AND TEST EQUIPMENT.....	1
TEST PROCEDURES AND RESULTS.....	2
TEST NO. 1, WEIGHT TEST.....	2
TEST NO. 2, LEAK TEST.....	2
TEST NO. 3, FREE FALL DROP TESTS (+140°F).....	2
TEST NO. 4, LEAK TEST.....	2
TEST NO. 5, FREE FALL DROP TESTS (-20°F).....	3
TEST NO. 6, LEAK TEST.....	3
TEST NO. 7, AMBIENT SUPERIMPOSED LOAD TEST.....	3
TEST NO. 8, LEAK TEST.....	3
TEST NO. 9, -400A VIBRATION FATIGUE TEST.....	4
TEST NO. 10, -400A LEAK TEST.....	4
TEST NO. 11, HOISTING STRENGTH TEST.....	4
TEST NO. 12, LEAK TEST.....	4
TEST NO. 13, HIGH TEMPERATURE, HIGH HUMIDITY SUPERIMPOSED LOAD TEST.....	5
TEST NO. 14, LEAK TEST.....	5
CONCLUSION.....	5

RECOMMENDATIONS.....	5
TABLE 1, CONTAINER TEST PLAN.....	6
FIGURE 1, -400 SIDE, LATCH AND HINGE NUMBERING.....	12
FIGURE 2, -400 PROTOTYPE CONTAINER.....	13
FIGURE 3, -400 CONTAINER CUSHIONING.....	13
FIGURE 4, AMBIENT SUPER IMPOSED LOAD TEST.....	14
DISTRIBUTION LIST.....	15

APPENDICES:

APPENDIX 1, DETAILED ACCELERATION RESULTS

INTRODUCTION

BACKGROUND: Aeronautical Systems Division (ASD/VXAL), Wright-Patterson AFB OH 45433-5000 requested assistance from the Air Force Packaging Evaluation Activity (AFPEA) to choose an off the shelf container for the signal data converter (D/C) and perform qualification testing. The container chosen was a plastic multipurpose container designed by Hardigg Industries, South Deerfield, MA 01373.

PURPOSE: The purpose of this project was to determine if the container design will protect the contents, one D/C for Combat Talon II aircraft, during worldwide shipment, storage, and handling.

DESCRIPTION OF TEST CONTAINER

The 11214-8678-400 prototype container, now referred to as -400 was subjected to extensive testing. The sides, latches and hinges of the container were numbered counterclockwise from the forward end as shown in figure 1.

Design: The -400 prototype is a controlled-breathing container with a pressure relief valve and humidity indicator (see figure 2). The container is designed to limit the transmission of shocks to the D/C to 40 Gs. The container cover is permanently hinged on one side and five wing latches on the remaining sides allow quick access to the container contents without the use of tools.

Construction: The container is rotationally molded from a formulation of polyethylene. Two pound density polyethylene foam encapsulates the item (see figure 3). A silicone gasket provides a seal between the container base and the container cover.

TEST OUTLINE AND TEST EQUIPMENT

Test Plan: Tests were conducted in accordance with AFPEA Test Plan 88-P-102 (see table 1). The tests used were selected to meet the qualification requirements for fragility and environmental sealing. Test methods, procedures and pass/fail criteria used were as outlined in Federal Test Method Standard No. 101 (FED-STD-101) and Military Standard 648. Any modifications to the standard procedures are noted in the test plan or the results.

Test Load: All tests were conducted using the D/C test load fabricated at the AFPEA. The test load weighs 22 pounds and simulates the center of gravity and the mass moment of inertia of an actual D/C.

Test Site: All testing was conducted at the AFPEA, HQ AFLC/DSTZ, Building 70, Area C, Wright-Patterson AFB OH 45433-5999. The equipment required for each test is noted in the test plan.

TEST PROCEDURES AND RESULTS

Weight Test

Test No. 1: The container was weighed to determine weight compliance.

Results: Total tare weight was 30.0 pounds. The result of this test is acceptable.

Leak Test

Test No. 2: The pneumatic pressure test was conducted in accordance with FED-STD-101, Method 5009.2 at 0.50 psig. The vacuum retention test was conducted in accordance with FED-STD-101, Method 5009.2 at 0.50 psig. The failure criteria for the test was 0.025 psig loss during a 30 minute period, after temperature and pressure stabilization.

Results: At the end of the 30 minute test period the pressure loss was 0.025 psig. At the end of the 30 minute test period the vacuum loss was 0.011 psig. The results of this test are acceptable.

Free Fall Drop Tests (+140°F)

Test No. 3: The high temperature free fall drop tests were conducted in accordance with FED-STD-101, Method 5007.1. Due to the location of the center of gravity the height of the drops varied see appendix 1 for detailed drop heights.

Results: Visual inspection revealed no external damage to the container. A maximum of 16 Gs was obtained during the tests.

The container was opened after the free fall drop tests. Visual inspection revealed no damage to the container or the test load. The results of these tests are acceptable. See appendix 1 for detailed acceleration results.

Leak Test

Test No. 4: The pneumatic pressure test was conducted in accordance with FED-STD-101, Method 5009.2. The test was performed at 0.50 psig. The failure criteria for the test was a 0.0125 psig loss during a 15 minute period after temperature and pressure stabilization.

Results: At the end of the 15 minute test period the pressure loss was 0.0125 psig. The result of this test is acceptable.

Free Fall Drop Tests (-20°F)

Test No. 5: The low temperature free fall drop tests were conducted in accordance with FED-STD-101, Method 5007.1. Due to the location of the center of gravity the drop heights varied. See appendix 1 for detailed drop heights.

Results: Visual inspection revealed no external damage to the container. A maximum of 21 Gs was obtained during the tests.

The container was opened after the free fall drop tests. Visual inspection revealed no damage to the container or the test load. However during cold conditioning the decals fell off the container. The results of this test are acceptable.

Leak Test

Test No. 6: The pneumatic pressure test was conducted in accordance with FED-STD-101, Method 5009.2. The test was performed at 0.50 psig. The failure criteria for the test was a 0.0125 psig loss during a 15 minute period after temperature and pressure stabilization.

Results: At the end of the 15 minute test period the pressure loss was 0.01 psig. The result of this test is acceptable.

Superimposed Load Test

Test No. 7: The ambient superimposed load test was conducted in accordance with FED-STD-101, Method 5016.1 (see figure 4). A load of 1232 pounds was placed on top of the container using load spreaders. This simulates the loading of a stack of ten containers with a safety factor of two on the bottom container.

Results: Visual inspection revealed no permanent deformation to the container. The result of this test is acceptable.

Leak Test

Test No. 8: The pneumatic pressure test was conducted in accordance with FED-STD-101, Method 5009.2. The test was performed at 0.50 psig. The failure criteria for the test was a 0.0125 psig loss during a 15 minute period after temperature and pressure stabilization.

Results: At the end of the 15 minute test period the pressure loss was 0.012 psig. The result of this test is acceptable.

Vibration Fatigue Test

Test No. 9: The vibration fatigue test was conducted in accordance with MIL-STD-648, paragraph 5.3.2. The container was rigidly attached to the platform. A sinusoidal vibration excitation was applied in a vertical direction and cyclically swept for 7.5 minutes at 2 minutes per octave to locate the resonant frequency. Input from 5 to 12.5 Hz was at 0.125 inch double amplitude and input from 12.5 to 50.0 Hz was at 1.0 G. A 30 minute dwell test was conducted at the resonant frequency.

Results: Visual inspection revealed no damage to the container or the test load. A maximum of 2.6 Gs was obtained at the resonant frequency of 12.2 Hz. The maximum transmissibility obtained was 1.1. The results of this test are acceptable.

Leak Test

Test No. 10: The pneumatic pressure test was conducted in accordance with FED-STD-101, Method 5009.2. The test was performed at 0.50 psig. The failure criteria for the test was a 0.0125 psig loss during a 15 minute period after temperature and pressure stabilization.

Results: At the end of the 15 minute test period the pressure loss was 0.01 psig. The result of this test is acceptable.

Hoisting Strength Test

Test No. 11: The single ring hoisting test was conducted in accordance with MIL-STD-648, paragraph 5.8.5. The loaded container was lifted by a lift ring and suspended for five minutes.

Results: Visual inspection of the container revealed no damage or deformation. The result of this test is acceptable.

Leak Test

Test No. 12: The pneumatic pressure test was conducted in accordance with FED-STD-101, Method 5009.2. The test was performed at 0.50 psig. The failure criteria for the test was a 0.0125 psig loss during a 15 minute period after temperature and pressure stabilization.

Results: At the end of the 15 minute test period the pressure loss was 0.006 psig. The result of this test is acceptable.

Superimposed Load Test

Test No. 13: The high temperature, high humidity superimposed load test was conducted in accordance with FED-STD-101, Method 5016.1. A load of 616 pounds was placed on top of the container using load spreaders this simulates the loading of a stack of ten containers with a safety factor of one on the bottom container.

Results: Visual inspection revealed a permanent deformation of the container. This deformation did not cause any damage to the D/C or impair stackability.

Leak Test

Test No. 14: The pneumatic pressure test was conducted in accordance with FED-STD-101, Method 5009.2. The test was performed at 0.50 psig. The failure criteria for the test was a 0.0125 psig loss during a 15 minute period after temperature and pressure stabilization.

Results: The container would not pressurize and a leakage rate could not be obtained. This occurred due to the permanent deformation of the container from the high temperature, high humidity superimposed load test.

CONCLUSION

The -400 prototype container provided adequate mechanical protection for the contents when tested in accordance with the container test plan. However, the container provides marginal environmental protection, especially if the container will be shipped and/or stored in a stacked configuration under tropical conditions.

RECOMMENDATIONS

The container should have wing latches only, no hinges. Additional cushion cut outs around the pressure relief valve and humidity indicator. Decals on the containers need better adherence for cold temperature environments. Container walls need to be made stiffer for more stability. The container should not be used for long term storage.

Table 1. Test Plan

AIR FORCE PACKAGING EVALUATION ACTIVITY (Container Test Plan)				AFPEA PROJECT NUMBER 88-P-102		
CONTAINER SIZE (L x W x D) (INCHES)		WEIGHT (LBS)		CUBE (CU. FT.)	QUANTITY	DATE
INTERIOR:	EXTERIOR:	GROSS:	ITEM:			
						3 Jul 89
ITEM NAME LRUs				MANUFACTURER Hardigg Industries		
CONTAINER NAME Part numbers 11214-8678-400				CONTAINER COST		
PACK DESCRIPTION Composite Container						
CONDITIONING As noted below.						
TEST NO.	REF STD/SPEC AND TEST METHOD OR PROCEDURE NO'S	TEST TITLE AND PARAMETERS	CONTAINER ORIENTATION	INSTRUMENTATION		
1.	<u>WEIGHT TEST</u>	Total container weight should not be less than 30 lbs.	Fully assembled container including shock isolation system.	Scale		
2.	<u>LEAK TEST</u> FED-STD-101 Method 5009.2	Pneumatic pressure at 0.50 PSIG and vacuum retention at 0.50 PSIG. Test duration to be a minimum of 30 minutes with 0.025 PSIG loss allowed after temperature stabilization.	Test at ambient condition from compressed air supply/vacuum pump.	Water manometer		
3.	<u>FREE FALL DROP TESTS (HIGH TEMPERATURE +140°F)</u> FED-STD-101 Method 5007.1	Free fall drop test. Condition at +140°F for not less than 24 hours. Drop height 18 inches or maximum height where container does not tilt over on side. Peak resultant acceleration shall not exceed 40Gs.	Test performed in chamber. Drop on half of sides and corners, total of four drops.*	Tri-axial accelerometers		
COMMENTS: * Remaining impacts to be performed in Test No. 5.						
PREPARED BY: <i>Susan Hughey</i> Susan Hughey, Mechanical Engineer				APPROVED BY: <i>Ted Hinds</i> Ted Hinds, Chief, Design Br., AFPEA		

AIR FORCE PACKAGING EVALUATION ACTIVITY

(Container Test Plan)

AFPEA PROJECT NUMBER

88-P-102

CONTAINER SIZE (L x W x D) (INCHES) INTERIOR:	WEIGHT (LBS) GROSS:	CUBE (CU. FT.)	QUANTITY	DATE
EXTERIOR:	ITEM:			3 Jul 89

ITEM NAME LRUs	MANUFACTURER Hardigg Industries
-------------------	------------------------------------

CONTAINER NAME Part numbers 11214-8678-400	CONTAINER COST
---	----------------

PACK DESCRIPTION
Composite Container

CONDITIONING
As noted below.

TEST NO.	REF STD/SPEC AND TEST METHOD OR PROCEDURE NO'S	TEST TITLE AND PARAMETERS	CONTAINER ORIENTATION	INSTRUMENTATION
4.	<u>LEAK TEST</u> FED-STD-101 Method 5009.2	Pneumatic pressure with 0.50 PSIG. Test duration not less than 15 minutes with 0.0125 PSIG loss allowed after temperature stabilization.	Ambient	Water manometer
5.	<u>ROUGH HANDLING TESTS (LOW TEMPERATURE -20°F)</u> FED-STD-101 Method 5007.1	Free fall drop test. Condition at -20°F for not less than 24 hours. Drop height 18 inches or maximum height where container does not tilt over. Peak resultant acceleration shall not exceed 40Gs.	Test performed in chamber. Drop on half of sides and corners, total of four drops.*	Tri-axial accelerometers
6.	<u>LEAK TEST</u> FED-STD-101 Method 5009.2	Pneumatic pressure with 0.50 PSIG. Test duration not less than 15 minutes with 0.0125 PSIG loss allowed after temperature stabilization.	Ambient	Water manometer
7.	<u>SUPERIMPOSED LOAD (Ambient temperature)</u> FED-STD-101 Method 5016.1	At ambient temperature, stack two containers with additional load on top to simulate stacking	Stack two high, bottom container is under test.	Visual inspection

COMMENTS* These impacts are opposite those performed in Test No. 3.

PREPARED BY: Susan Hughey, Mechanical Engineer	APPROVED BY: Ted Hinds, Chief, Design Br., AFPEA
---	---

AIR FORCE PACKAGING EVALUATION ACTIVITY (Container Test Plan)				AFPEA PROJECT NUMBER	
				88-P-102	
CONTAINER SIZE (L x W x D) (INCHES)		WEIGHT (LBS)		CUBE (CU. FT.)	QUANTITY
INTERIOR:	EXTERIOR:	GROSS:	ITEM:		DATE
					3 Jul 89
ITEM NAME			MANUFACTURER		
LRUs			Hardigg Industries		
CONTAINER NAME				CONTAINER COST	
Part numbers 11214-86,8-400					
PACK DESCRIPTION					
Composite Container					
CONDITIONING					
As noted below.					
TEST NO.	REF STD/SPEC AND TEST METHOD OR PROCEDURE NO'S	TEST TITLE AND PARAMETERS	CONTAINER ORIENTATION	INSTRUMENTATION	
8.	<u>LEAK TEST</u> FED-STD-101 Method 5009.2	10 containers or 16 ft high, whichever is greater. Load equals load on bottom container times a factor of safety of 2. Test duration not less than 1 hour. Additional load placed on top container such that the total load is carried by the stacking provisions. There shall be no permanent deformation. Pneumatic pressure with 0.50 PSIG. Test duration not less than 15 minutes with 0.0125 PSIG loss allowed after temperature stabilization.	Ambient	Water manometer	
9.	<u>VIBRATION FATIGUE TEST</u> MIL-STD-648 Para 5.3.2	Input excitation of 0.125 inch double amplitude or 1G, whichever is less. Sweep approximately logarithmically from 5 to 50 Hz (about 1/2	Rigidly attach container to exciter. The use of straps is prohibited.	Triaxial accelerometers, Thermocouples	
COMMENTS:					
PREPARED BY:			APPROVED BY:		
Susan Hughey, Mechanical Engineer			Ted Hinds, Chief, Design Br., AFPEA		

AIR FORCE PACKAGING EVALUATION ACTIVITY

(Container Test Plan)

AFPEA PROJECT NUMBER

88-P-102

CONTAINER SIZE (L x W x D) (INCHES)
 INTERIOR: EXTERIOR:

WEIGHT (LBS)
 GROSS: ITEM:

CUBE (CU. FT.)

QUANTITY

DATE

3 Jul 89

ITEM NAME

LRUs

MANUFACTURER

Hardigg Industries

CONTAINER NAME

Part numbers 11214-8678-400

CONTAINER COST

PACK DESCRIPTION

Composite Container

CONDITIONING

As noted below.

TEST NO.	REF STD/SPEC AND TEST METHOD OR PROCEDURE NO'S	TEST TITLE AND PARAMETERS	CONTAINER ORIENTATION	INSTRUMENTATION
10.	<u>LEAK TEST</u> FED-STD-101 Method 5009.2	octave/min) for 7-1/2 minutes. Then dwell 30 minutes at the resonant frequency. The test may be interrupted to prevent excessive temperature rise in materials. Transmissibility shall not exceed 5 at the resonant frequency. Pneumatic pressure with 0.50 PSIG. Test duration not less than 15 minutes with 0.0125 PSIG loss allowed after temperature stabilization.	Ambient	Water manometer
11.	<u>HOISTING STRENGTH TEST</u> MIL-STD-648 Para. 5.8.5	Single ring hoisting test. Hoist container at one lift point and leave hanging for five minutes. There shall be no damage or permanent deformation.	Ambient	Visual inspection

COMMENTS:

PREPARED BY:

Susan Hughey, Mechanical Engineer

APPROVED BY:

Ted Hinds, Chief, Design Br., AFPEA

AIR FORCE PACKAGING EVALUATION ACTIVITY

(Container Test Plan)

AFPEA PROJECT NUMBER

88-P-102

CONTAINER SIZE (L x W x D) (INCHES) INTERIOR:	WEIGHT (LBS) GROSS:	CUBE (CU. FT.)	QUANTITY	DATE
EXTERIOR:	ITEM:			3 Jul 89

ITEM NAME LRUs	MANUFACTURER Hardigg Industries
-------------------	------------------------------------

CONTAINER NAME Part numbers 11214-8678-400	CONTAINER COST
---	----------------

PACK DESCRIPTION
Composite Container

CONDITIONING
As noted below.

TEST NO.	REF STD/SPEC AND TEST METHOD OR PROCEDURE NO'S	TEST TITLE AND PARAMETERS	CONTAINER ORIENTATION	INSTRUMENTATION
12.	<u>LEAK TEST</u> FED-STD-101 Method 5009.2	Pneumatic pressure with 0.50 PSIG. Test duration not less than 15 minutes with 0.0125 PSIG loss allowed after temperature stabilization.	Ambient	Water manometer
13.	<u>SUPERIMPOSED LOAD (High temperature and humidity)</u> FED-STD-101 Method 5016.1	Condition at 120°F and 90% relative humidity for 168 hours a stack of two containers with additional load on top to simulate stacking 10 containers or 16 ft high, whichever is greater. Load equals load on bottom container times a factor of safety of 1. Additional load placed on top container such that the total load is carried by the stacking provisions. There shall be no permanent deformation.	Stack two high, bottom container is under test.	Visual inspection

COMMENTS:

PREPARED BY: Susan Hughey, Mechanical Engineer	APPROVED BY: Ted Hinds, Chief, Design Br., AFPEA
---	---

AIR FORCE PACKAGING EVALUATION ACTIVITY

(Container Test Plan)

AFPEA PROJECT NUMBER

88-P-102

CONTAINER SIZE (L x W x D) (INCHES)
 INTERIOR: EXTERIOR:

WEIGHT (LBS)
 GROSS: ITEM:

CUBE (CU. FT.)

QUANTITY

DATE

3 Jul 89

ITEM NAME

LRUs

MANUFACTURER

Hardigg Industries

CONTAINER NAME

Part numbers 11214-8678-400

CONTAINER COST

PACK DESCRIPTION

Composite Container

CONDITIONING

As noted below.

TEST NO.	REF STD/SPEC AND TEST METHOD OR PROCEDURE NO'S	TEST TITLE AND PARAMETERS	CONTAINER ORIENTATION	INSTRUMENTATION
14.	<u>LEAK TEST</u> FED-STD-101 Method 5009.2	Pneumatic pressure with 0.50 PSIG. Test duration not less than 15 minutes with 0.0125 PSIG loss allowed after temperature stabilization.	Ambient	Water Manometer

COMMENTS:

PREPARED BY:

Susan Hughey, Mechanical Engineer

APPROVED BY:

Ted Hinds, Chief, Design Br., AFPEA

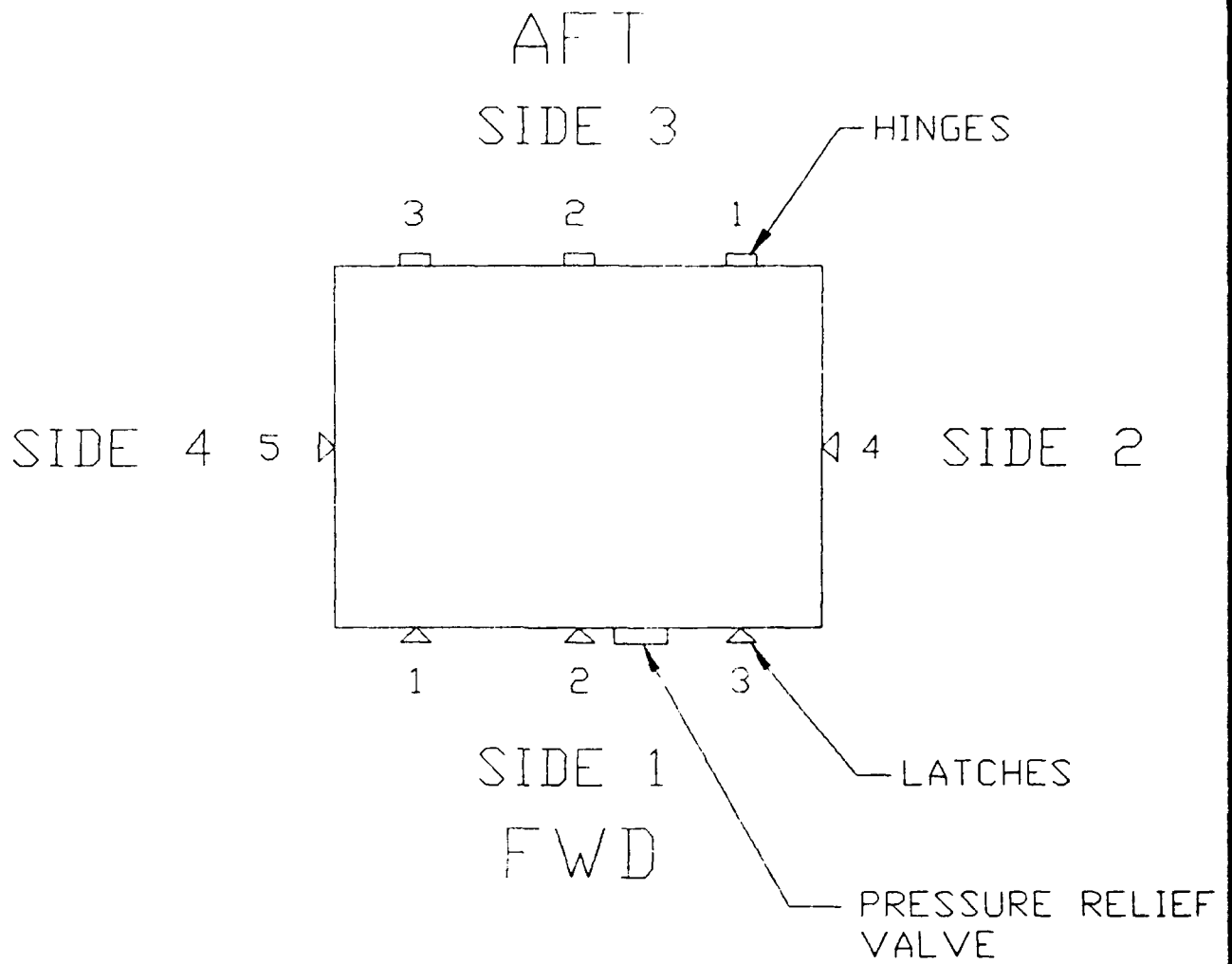

FIGURE 1. -400 Side, Latch and Hinge Numbering.

Figure 2
-400
Prototype
Container.

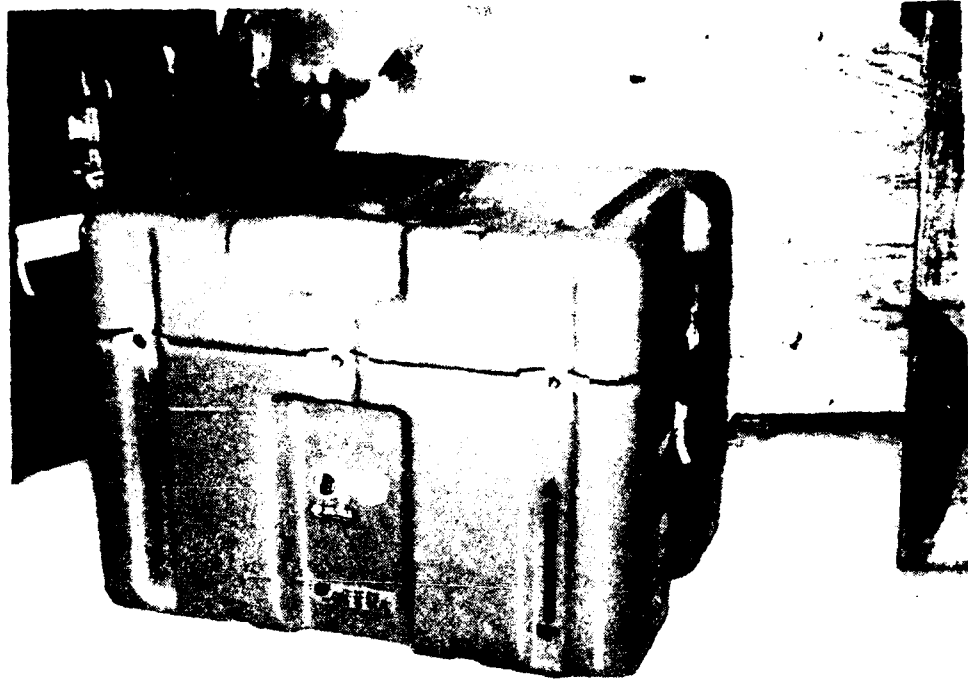

Figure 3
-400
Container
Cushioning.

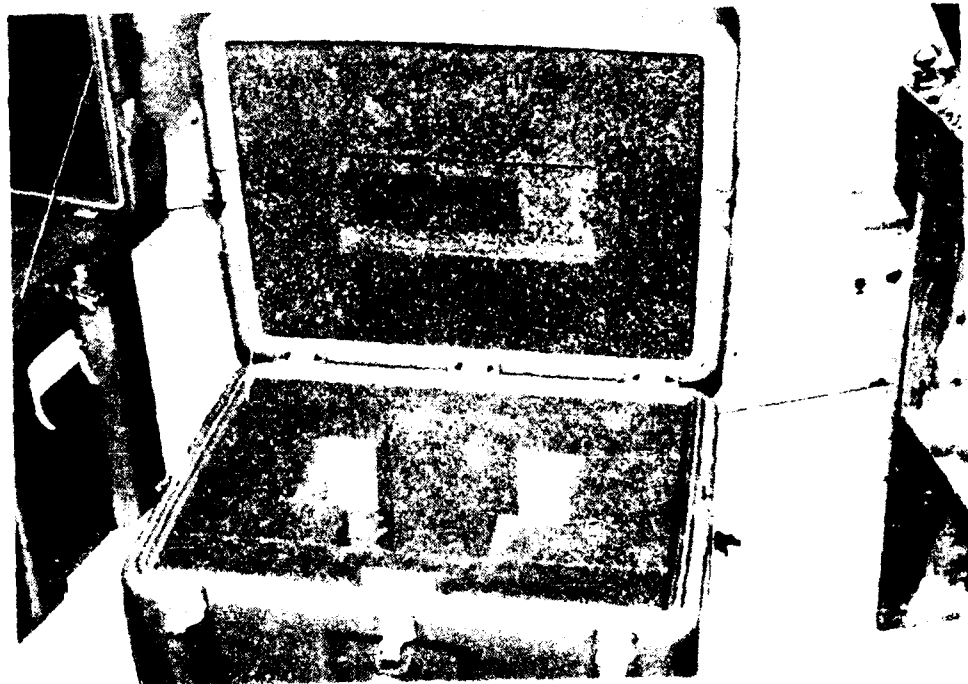
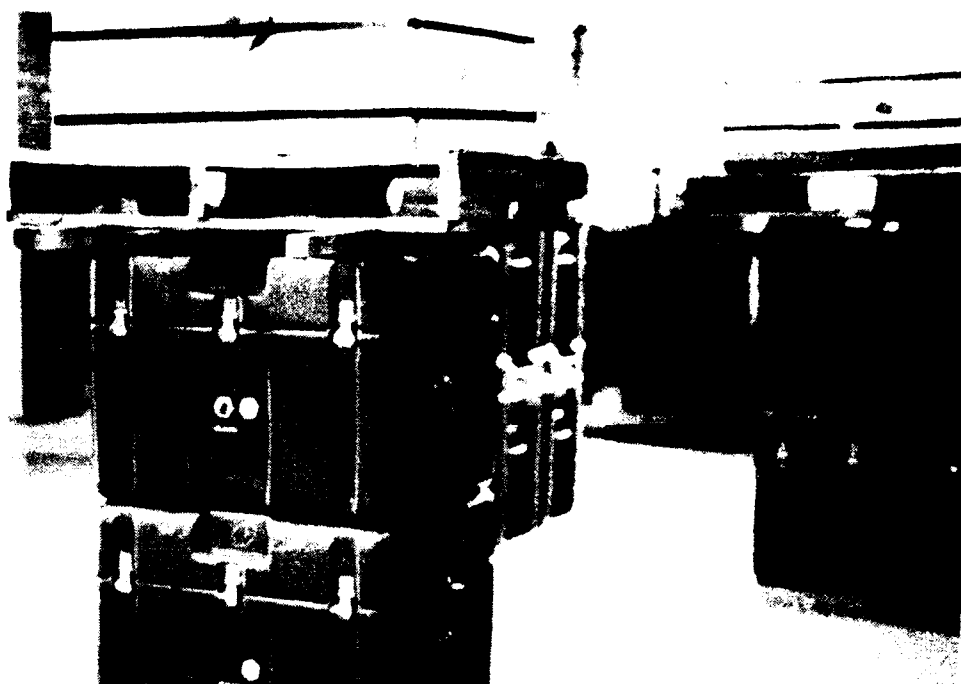

Figure 4

-400
Ambient
Super Imposed
Load Test.



DISTRIBUTION LIST

DTIC/FDAC Cameron Station Alexandria, VA 22304-6145	2
HQ AFLC/DSTZ Library Wright-Patterson AFB OH 45433-5999	10
HQ USAF/LETT Washington DC 20330	1
HQ AFSC/LGT Andrews AFB DC 20334-5000	1
OC-ALC/DSTP Tinker AFB OK 73145	1
OO-ALC/DSTP Hill AFB UT 84406	1
SA-ALC/DSTP Kelly AFB TX 78241	1
SM-ALC/DSTP McClellan AFB CA 95652	1
WR-ALC/DSTP Robins AFB GA 31098	1
ASD/ALXP/SDM Wright-Patterson AFB OH 45433	1
AFLC LOC/TL/AMS/AMP Wright-Patterson AFB OH 45433	3
AF ALC/OA Wright-Patterson AFB OH 45433	2
HQ TAC/LGWL Langley AFB VA 23665-5001	2
GSA, Office of Engineering Mgt Packaging Division Washington DC 20406	1
AFSC MSD/YBAC Eglin AFB FL 32542	1

DISTRIBUTION LIST (Cont'd)

Commander Naval Supply Systems Command Attn: N. Karl (SUP 0611F) Washington DC 20376-5000	1
Commander Naval Air Systems Command Attn: E. Panigot (AIR 41212A) Washington DC 20361	1
Commander Space and Naval Warfare Systems Command Attn: T. Corbe (Code 8218) Washington DC 20360	1
Commander Naval Facilities Engineering Command Hoffman Bldg. #2, Room 12S21 Attn: C. Manwarring (FAC 0644) Alexandria, VA 22332	1
Commanding Officer Naval Construction Battalion Center Attn: K. Pollock (Code 15611K) Port Hueneme, CA 93043	1
Commander Naval Sea Systems Command Attn: F. Basford (SEA 05M3) Washington DC 20362	1
Commanding Officer Naval Aviation Supply Office 700 Robbins Avenue Attn: H. FURLONG Philadelphia, PA 19111-5098	1
Commanding Officer Navy Ships Parts Control Center P.O. Box 2020 Attn: F. Sechrist (Code 0541) Mechanicsburg, PA 17055-0788	1
Commanding Officer Naval Air Engineering Center Attn: F. Magnifico (SESD Code 9321) Lakehurst, NJ 08733-5100	1

DISTRIBUTION LIST (Cont'd)

Commanding Officer Naval Weapons Station, Earle ATTN: NWHC 80A (Mel Gray) NWHC/Code 8023 Colts Neck, NJ 07722-5000	1
Commander USAMCPSCC Attn: SDSTO-TM Tobyhanna, PA 18466-5097	1
DLSIE/AMXMC-D US Army Logistics Mgt Ctr Ft Lee VA 23801-6034	1
Commander US Army Armament Munitions & Chemical Command, Attn: SMCAR-AEP (Mike Ivanroe) Bldg 455 Picatinny, NJ 07801-5000	1
HQ DLA/OWP Cameron Station Alexandria, VA 22304-6100	1
ASD/VXAL Wright-Patterson AFB OH 45433	2
ASD/VXA Wright-Patterson AFB OH 45433	1

-400 CONTAINER - DETAILED ACCELERATION RESULTS

HIGH TEMPERATURE ROUGH HANDLING TESTS (+140^o F)

Impact	Position	Accelerometer readings (Gs)	
			Resultant
18" free fall drop	Corner 1-2		10
18" free fall drop	Corner 3-4		12
17" free fall drop	Side 3		15
18" free fall drop	Side 4		16

1. No damage to the container or the test load.
-

LOW TEMPERATURE ROUGH HANDLING TESTS (-20^o F)

Impact	Position	Accelerometer readings (Gs)	
			Resultant
17" free fall drop	Corner 1-4		18
17" free fall drop	Corner 2-3		21
17" free fall drop	Side 1		6
17" free fall drop	Side 2		21

1. No damage to the container or the test load.
-

VIBRATION FATIGUE TEST

Natural frequency 12.2 Hz
(input: 1.04 G peak, 0.125 inch double amplitude)

	Resultant
Maximum Acceleration (Gs, peak to peak)	2.6
Maximum Transmissibility	1.1

1. No damage to the container or the test load.
-