

4

DTIC FILE COPY

AD-A211 830

AFGL-TR-89-0021
ENVIRONMENTAL RESEARCH PAPERS, NO. 1018

A Beam Induced Upset During the Flight of the ECHO-7 Rocket

PERRY R. MALCOLM
WILLIAM J. BURKE
GEORGE P. MURPHY



13 January 1989



Approved for public release; distribution unlimited.



DTIC
ELECTE
AUG 28 1989
S Q E D

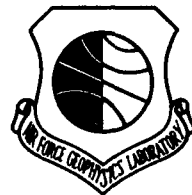

SPACE PHYSICS DIVISION PROJECT 7601
AIR FORCE GEOPHYSICS LABORATORY
HANSCOM AFB, MA 01731

89 8 28 103

"This technical report has been reviewed and is approved for publication"

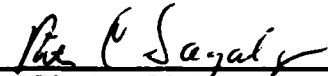
RITA C. SAGALYN, Director
Space Physics Division

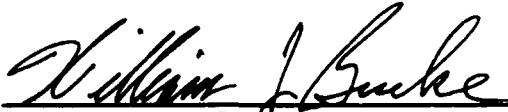
WILLIAM J. BURKE, Chief
Active Space Experiments Branch

This report has been reviewed by the ESD Public Affairs Office (PA) and is releasable to the National Technical Information Service (NTIS).

Qualified requestors may obtain additional copies from the Defense Technical Information Center. All others should apply to the National Technical Information Service.

If your address has changed, or if you wish to be removed from the mailing list, or if the addressee is no longer employed by your organization, please notify AFGL/DAA, Hanscom AFB, MA 01731. This will assist us in maintaining a current mailing list.

Do not return copies of this report unless contractual obligations or notices on a specific document requires that it be returned.

REPORT DOCUMENTATION PAGE

Form Approved
OMB No. 0704-0188

1a. REPORT SECURITY CLASSIFICATION Unclassified			1b. RESTRICTIVE MARKINGS N/A			
2a. SECURITY CLASSIFICATION AUTHORITY N/A			3. DISTRIBUTION / AVAILABILITY OF REPORT Approved for public release; distribution unlimited.			
2b. DECLASSIFICATION / DOWNGRADING SCHEDULE N/A						
4. PERFORMING ORGANIZATION REPORT NUMBER(S) AFGL-TR-89-0021 ERP, No. 1018			5. MONITORING ORGANIZATION REPORT NUMBER(S)			
6a. NAME OF PERFORMING ORGANIZATION Air Force Geophysics Laboratory		6b. OFFICE SYMBOL (If applicable) PHA	7a. NAME OF MONITORING ORGANIZATION			
6c. ADDRESS (City, State, and ZIP Code) Hanscom AFB Massachusetts 01731-5000			7b. ADDRESS (City, State, and ZIP Code)			
8a. NAME OF FUNDING / SPONSORING ORGANIZATION		8b. OFFICE SYMBOL (If applicable)	9. PROCUREMENT INSTRUMENT IDENTIFICATION NUMBER			
8c. ADDRESS (City, State, and ZIP Code)			10. SOURCE OF FUNDING NUMBERS			
			PROGRAM ELEMENT NO. 61102F 62101F	PROJECT NO. 2311 7601	TASK NO. G6 50	WORK UNIT ACCESSION NO. 01 01
11. TITLE (Include Security Classification) A Beam Induced Upset During The Flight Of The ECHO-7 Rocket						
12. PERSONAL AUTHOR(S) Malcom, P.R., Burke, W.J., and Murphy, G.P.						
13a. TYPE OF REPORT Scientific Interim		13b. TIME COVERED FROM _____ TO _____	14. DATE OF REPORT (Year, Month, Day) 1989 January 13		15. PAGE COUNT 24	
16. SUPPLEMENTARY NOTATION None						
17. COSATI CODES			18. SUBJECT TERMS (Continue on reverse if necessary and identify by block number)			
FIELD	GROUP	SUB-GROUP	- Spacecraft Charging, Beam Plasma Interactions, Electron Beams ()			
20	09	03				
22	02	01				
19. ABSTRACT (Continue on reverse if necessary and identify by block number) During the flight of the ECHO-7 rocket, electron beams with energies and currents up to 40 keV and 250 mA were emitted at pitch angles controlled by a deflection magnet and successfully detected upon reflection in the southern ionosphere. Three anomalies occurred onboard the beam emitting main payload, one of which is presented in detail. While emitting at 36 keV and 180 mA and with the deflection magnet turned off, the vehicle potential was measured to be greater than 5 kV. During a 30 ms pulse of gas from the attitude control system the vehicle rapidly discharged, a power converter for several diagnostic sensors failed and a safety circuit was activated to shut the electron beam off. Two qualitative models of the consequences of ionization of the neutral cloud by beam and return current electrons are examined. An understanding of the interactions of neutral gas clouds with charged vehicles is of capital importance for the design of reliable high-power space platforms.						
20. DISTRIBUTION/AVAILABILITY OF ABSTRACT <input type="checkbox"/> UNCLASSIFIED/UNLIMITED <input checked="" type="checkbox"/> SAME AS RPT. <input type="checkbox"/> DTIC USERS			21. ABSTRACT SECURITY CLASSIFICATION Unclassified			
22a. NAME OF RESPONSIBLE INDIVIDUAL William Burke		22b. TELEPHONE (Include Area Code) 617-377-3980		22c. OFFICE SYMBOL AFGL/PHA		

Preface

The authors wish to express their gratitude to Professor John Winckler of the University of Minnesota for inviting them to participate in the ECHO-7 rocket program. The University of Minnesota's work was supported by Grant NSG 5088 from the Space Plasmas Division, NASA Headquarters. Work done at AFGL was supported by PE 62101F, Project 7601 and PE 61102F, Task 2311G601.

Accession For	
NTIS CRA&I	<input checked="" type="checkbox"/>
DTIC TAB	<input type="checkbox"/>
Unannounced	<input type="checkbox"/>
Justification	
By	
Distribution	
Availability Codes	
Dist	
A-1	



Contents

1. INTRODUCTION	1
2. ECHO 7 MISSION AND PAYLOAD	2
3. MAIN PAYLOAD POTENTIAL VARIATIONS	10
4. A SIMPLE ANOMALY MODEL	13
REFERENCES	17

Illustrations

1.	Photograph of the Burned Interior of the SCEX-2 Payload After Recovery	3
2.	Schematic Representation of the Primary Objective of the ECHO-7 Mission	4
3.	Configuration of the Four Free-flying ECHO-7 Payloads	6
4.	Diagram Representing the Main Components of the ECHO-7 Electron Beam Emission System	7
5.	The 10-Second, Programed Electron Beam Emission Sequence	9
6.	Altitude versus Time Trajectory of the ECHO-7 Rocket Flight	11
7.	MAIN-Tether Data Acquired During the Interval 282 - 284 s After Launch	12
8.	High Resolution Representation of Data Shown in Figure 7 During 53 ms Near the Time of Gun Shutdown	14

A Beam-Induced Upset During the Flight of the ECHO-7 Rocket

1. INTRODUCTION

On the evening of 8 February 1988, at 23:16:49, a scientific payload called ECHO-7 was launched on a Terrier-Black Brant V sounding rocket from the Poker Flat Research Range. ECHO-7 was a sophisticated experiment designed to study the complex interactions of artificial electron beams propagating great distances along magnetic field lines in space. An energetic electron beam can interact with itself, with the space environment, or with the host vehicle. This report concentrates on a nearly catastrophic interaction of the ECHO-7 electron beam system with the carrier vehicle. This event occurred near apogee, 292 km, during a 36 keV, 180 mA beam pulse. It destroyed the power converter for several diagnostic sensors and triggered a pre-programmed safety circuit that temporarily shut down the beam emission.

Because beam-induced spacecraft anomalies are well known hazards of the trade, it is useful to consider a few of the many documented cases. During an electron beam emission operation on the SCATHA (P78-2) satellite, severe arcing was induced, an energetic electron spectrometer was destroyed and the main telemetry system was temporarily impaired.¹ At the time of these upsets the beam energy and current were 3 keV and 13 mA (39 W), respectively. Data from the Norwegian rocket

(Received for publication 13 January 1989)

1. Cohen, H.A., Adamo, R.C., Aggson, T., Chesley, A.L., Clark, D.M., Dameron, S.A., Delroy, D.E., Fennell, J.F., Gussenhoven, M.S., Hanser, F.A., Hall, D., Hardy, D.A., Huber, W.B., Katz, I., Koons, H.C., Lal, S.T., Ledley, B., Mizera, P.F., Rubin, A.G., Schnulle, G.W., Saflekos, N.A., Tautz, M.F., and Whipple, E.C. (1981) P78-2 Satellite and Payload Responses to Electron Beam Operations on March 30, 1979, in *Spacecraft Charging Technology 1980*, NASA CP 2182; AFGL-TR-81-0270, ed. by Stevens, N.J. and Pike, C.P., ADA114426, 509 - 559.

MAIMIK indicate that whenever currents from its 8 kV gun exceeded 84 mA (640 W) the vehicle charged to at least beam energy.² During one MAIMIK charging event, a spurious command was induced causing a pyrotechnic device to detonate prematurely. Shortly after the electron gun on the BERT-1 rocket was turned on, with beam energy and current at 2 keV and 20 mA (40 W), the main telemetry encoder and the experiment sequencer were destroyed. Most recently, when the electron beam system on the SCEX-2 rocket was turned on, arcing from the battery pack-to-ground resulted in their destruction.³ Figure 1 is a photograph of the recovered SCEX payload that shows some results of the internal arcing.

None of these cases involves human carelessness. In all instances the beam systems were tested in laboratories for many hours prior to launch. Rather, they testify to the inherently hazardous conditions that develop whenever energetic particle beams are emitted into space plasmas. The particle beam systems envisaged by SDIO for the mid-nineties involve megawatts of primary power. Thus, it is imperative to carefully consider the circumstances surrounding all beam-induced systems anomalies. The often quoted aphorism "He who ignores history is doomed to repeat it," seems especially relevant.

Recently Banks et al⁴ reported on the results of the CHARGE-2 rocket, which was a tethered mother-daughter payload that emitted a 1 keV electron beam with currents up to 40 mA. The potential of the mother was normally high. However, when gas was released from the attitude control system on the tethered daughter vehicle, the potential of the mother decreased dramatically. They suggest that ionization of neutral gas during attitude control (ACS) releases allows more neutralizing current to flow from the environment, thus reducing the vehicle's electric potential. If validated, this technique may provide a simple and safe method for assuring that energetic electron beams get away from emitting bodies in space.

This report is divided into three main sections: (1) we summarize the ECHO-7 mission and its payload complement; (2) we give a detailed presentation of data acquired near the time of the beam-related anomaly, which included a neutral gas release; (3) we consider two simple models that qualitatively help our understanding of the anomaly.

2. ECHO-7 MISSION AND PAYLOAD

The main purpose of the ECHO-7 experiment was to study the propagation characteristics of energetic electron beams travelling great distances along the earth's magnetic lines of force. The central concept is illustrated in Figure 2. Electron beams are emitted from the rocket over Alaska.

-
2. Maehlum, B.N., Troim, J., Maynard, N.C., Denig, W.F., Friedrich, M., and Torkar, K.M. (1988) Studies of the electrical charging of the tethered electron accelerator mother-daughter rocket MAIMIK, *Geophys. Res. Lett.* **15**: 725-728.
 3. Massey, D.E., Williams, C.P., Ransone E.D., Eddy, T.E., and Monson, S.J. (1987) *Black Brant 36.004 UE Final Failure Report*, NASA Goddard Space Flight Center, Wallops Flight Facility.
 4. Banks, P.M., Gilchrist, B.E., Neubert, T., Bush, R.I., Williamson, P.R., Meyers, N., and Raitt, W.J. (1988) Rocket observations of electron beam experiments with vehicle charging neutralized by neutral gas plumes, XXVII COSPAR, 18 - 29 July 1988, Espoo Finland, Topical Meeting on Active Experiments, 343.



Figure 1. Photograph of the Burned Interior of the SCEX-2 Payload After Recovery

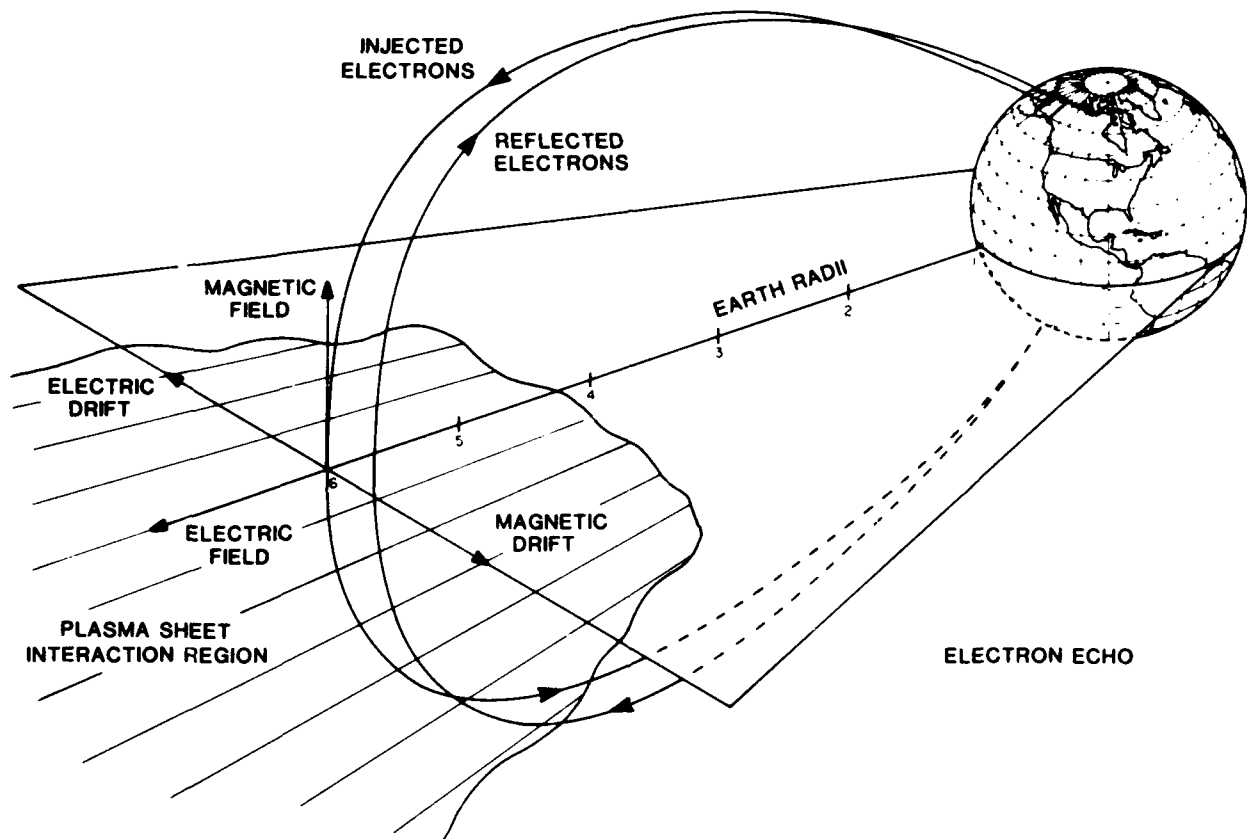

Figure 2. Schematic Representation of the Primary Objective of the ECHO-7 Mission: to measure the flux of energetic electrons that have reflected from the southern ionosphere and returned to the vicinity of their origin over Alaska.

Guided by the earth's magnetic field, they propagate to the southern ionosphere to the west of Antarctica. Here, they are reflected either by mirroring off the intensifying magnetic field or scattering off the atmosphere. Upon reflection to the northern hemisphere, the electrons can be detected by sensors deployed on or near the beam-emitting vehicle. The time delay between beam emission and the detection of electron echoes can be used to calculate the shapes of field lines threading the distant magnetosphere. Indeed, electron echoes were detected by particle sensors on all four of the free-flying payloads.⁵ The ratio of emitted-to-reflected electrons gives clues about pitch angle scattering processes that lead to beam trapping in the magnetosphere.

Secondary objectives of the mission included expanding our understanding of how charged particle beams interact with the ionospheric plasma environments and with their host vehicles. Environmental effects include the ionization or excitation of atmospheric neutrals, and collective interactions with charged particles in the beam or ionospheric plasma. Interactions with neutrals manifest themselves mostly through the emission of light. Beam-plasma interactions lead to the emission of electrostatic and/or electromagnetic waves in the VLF and HF frequency bands. The most important interaction with the host vehicle involves surface charging and the development of high potential sheaths. Arcing associated with rapid charging or discharging of a vehicle is particularly hazardous for electronic circuits operating inside the emitting body.

Figure 3 sketches the configuration of the ECHO-7 science payload. The instrumented nosecone section (NOSE), ejected within a few degrees of the magnetic field line, was primarily designed to detect waves generated in or near the beam. The Plasma Diagnostics Package (PDP) and the Energetic Particles Payload (EPP) were ejected to the magnetic south and west of the beam-emitting MAIN payload. They each carried sensors to detect echoing, energetic electrons and beam-related electromagnetic fields. The PDP also carried a low-light level television camera that pointed back along the spin axis toward the positions of MAIN. Detailed descriptions of the NOSE, PDP and EPP complement of instruments have been written by the ECHO science team.⁵ They are not needed for the present study. In what follows we concentrate on the MAIN payload's instrumentation and operations.

The MAIN payload was made up of three subsections responsible for attitude control, telemetry, and science. The attitude control system (ACS) consisted of a pressurized nitrogen container with pitch, roll and yaw jet nozzles to maintain three-axis stability. After initial payload deployments, further gas emissions occurred randomly throughout the flight to keep the orientation of MAIN perpendicular to the earth's magnetic field. The MAIN telemetry subsystem was a 400 kb/s PCM encoder and transmitter.

The core of the ECHO-7 scientific experiment was a 10 kW electron beam accelerator, shown schematically in Figure 4, that was designed, built and tested at the Air Force Geophysics Laboratory (AFGL). It functioned perfectly from turn-on at 179 s (250 km) through reentry at 500 s (90 km) while emitting beams reaching 40 keV in energy and 250 mA in current. The accelerator was similar to

5. Winckler, J.R., Malcolm, P.R., Arnoldy, R.L., Burke, W.J., Erickson, K.N., Ernstmeyer, J., Franz, R.C., Hallinan, T.J., Kellogg, P.J., Lynch, K.A., Monson, S.J., Murphy, G.P., and Nemzek, R.J. (1989) ECHO-7: An Electron Beam Experiment in the Magnetosphere, (Submitted for Publication) *EOS: Trans. Amer. Geophys. U.*

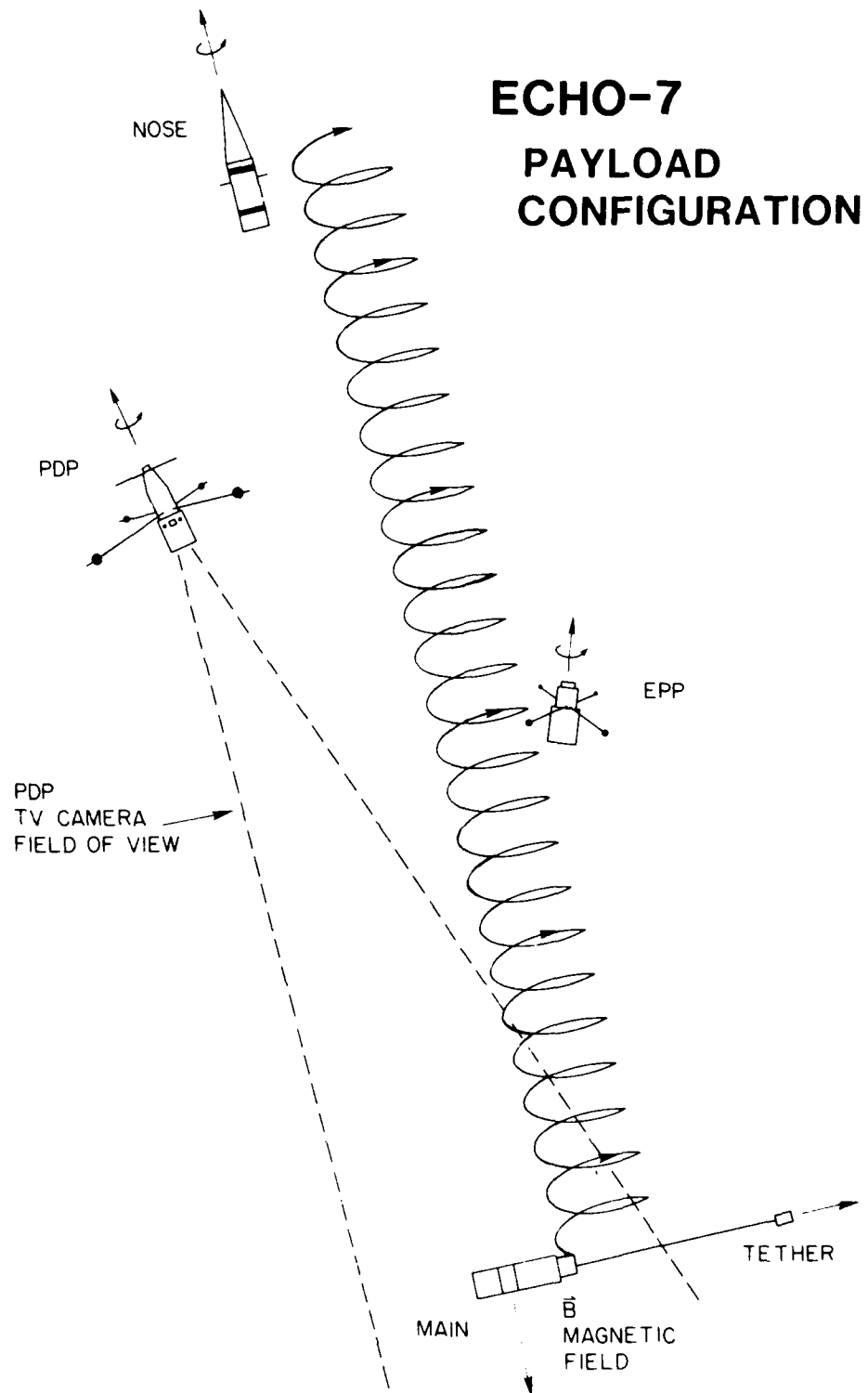

Figure 3. Configuration of the Four Free-Flying ECHO-7 Payloads. NOSE was ejected straight up the magnetic field line, the Plasma Diagnostics Payload 10° to the magnetic south and the Energetic Electron Payload 25° to the magnetic west of the electron beam emitting MAIN payload.

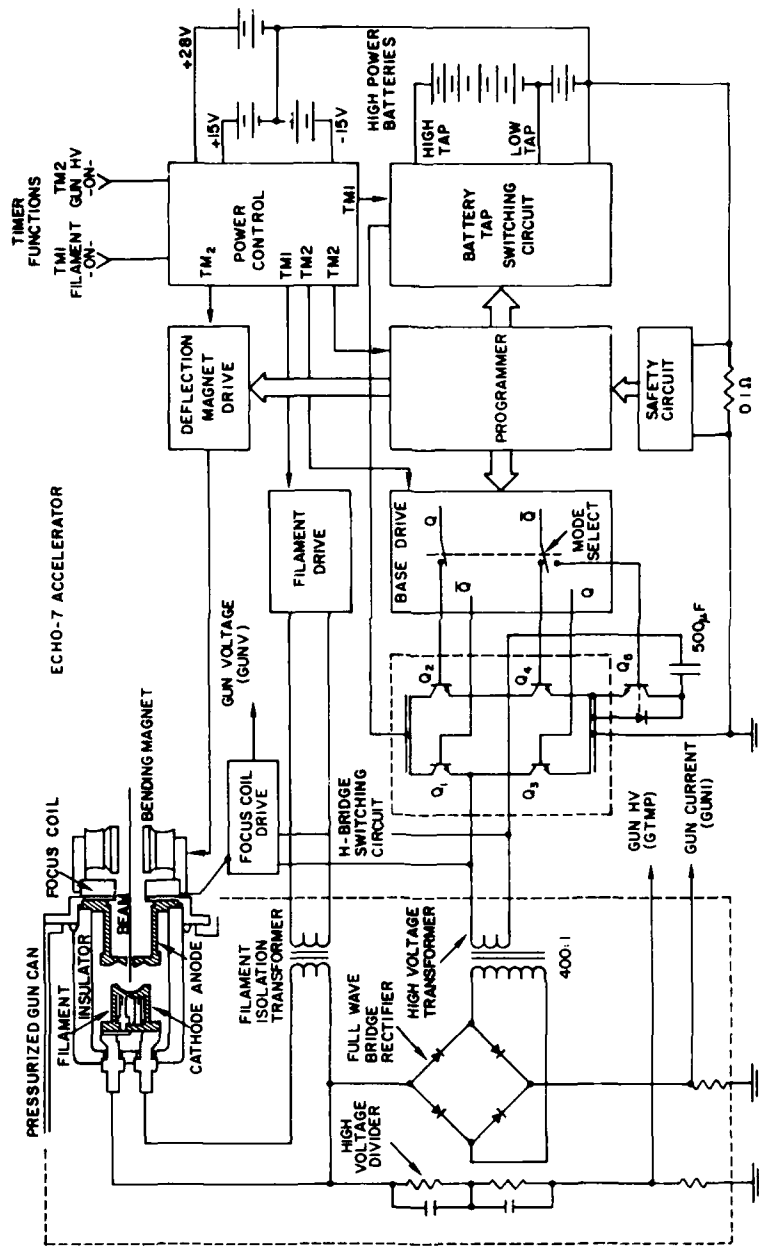

Figure 4. Diagram Representing the Main Components of the ECHO-7 Electron Beam Emission System

those flown on previous ECHO missions, but incorporated several design changes to increase program flexibility. It had five basic components: a battery power system, power converters, a diode electron emitter or gun, beam focusing and deflection magnets, and a programmer to control functions during flight.

Primary power was supplied by four silver-zinc battery packs capable of delivering up to 100 V at 100 A when connected in series. Power was taken from the batteries at one of two taps selected by the programmer. The high (low) voltage tap was connected to the 100 V (25 V) load point. This power fed the primary side of a DC-DC converter that stepped the 100 V up to 40 kV with a maximum current of 250 mA. The square wave output of the converter was full-wave-rectified to produce a DC output with <10 percent ripple. No attempt was made to filter the output because of the hazards involved.

The electron gun was a space-charge-limited diode with a geometry described by Pierce.⁶ The source of electrons was a tantalum ribbon filament heated to incandescence with a floating power supply. The filament and cathode-focusing element were biased to the negative high-voltage output of the accelerator convertor while the gun anode was grounded to the payload skin. Since the gun was not emission-limited within its operating range, it was capable of producing a beam current of 250 mA with a -40 kV bias and 10 mA with a -10 kV bias, following the $V^{3/2}$ relation for a space-charge-limited diode.

The accelerator was placed on the payload so that when MAIN was stabilized perpendicular to the earth's magnetic field, the injection pitch angle of beam electrons with no magnetic deflection was 110° . With the deflection magnet turned on, other injection pitch angles were possible when the accelerator was in the "discrete" mode. These were downward at a pitch angle of 40° , upward at a pitch angle of 170° and a continuous sweep from 40° to 170° . In the "continuous" accelerator mode the beam always emitted at a pitch angle of 110° .

All the accelerator emission modes and beam-deflection angles were controlled by a simple programmer sequence interfaced to the accelerator drive circuits through fiber-optic links for maximum noise immunity. A 200-step accelerator program was burned into EPROMS that were read every 50 ms in a program of 10 s duration. Figure 5 shows that the program consisted of a mix of "discrete" injections at two different energies and four series of coded pulses in the "continuous" mode. The code consisted of various sequences of 50, 100, and 150 ms duration pulses that allowed identification of exactly which pulses were detected as conjugate echoes.

A quasi-DC voltage was used to drive the "discrete" accelerator mode which produced beams of nearly constant energies when connected to the gun diode. The second, or "continuous" accelerator mode, used the converter drive to charge and discharge a 500 pF capacitor during each drive cycle. When the transformed output was full-wave-rectified, the resultant output decayed exponentially from 40 kV to 8 kV during each 1 ms half-cycle. This mode is called "continuous" because it results in an electron beam continuously spread in energies between 40 and 8 keV. Continuous mode beams were used to enhance the probability of echo detection.⁵

Care was taken to prevent catastrophic disruption of the power convertor system caused by high-voltage breakdown in the gun. A safety circuit was designed to monitor the battery current and to

6. Pierce, J.R. (1949) *Theory and Design of Electron Beams*, D. Van Nostrand Co., New York, 167 - 187.

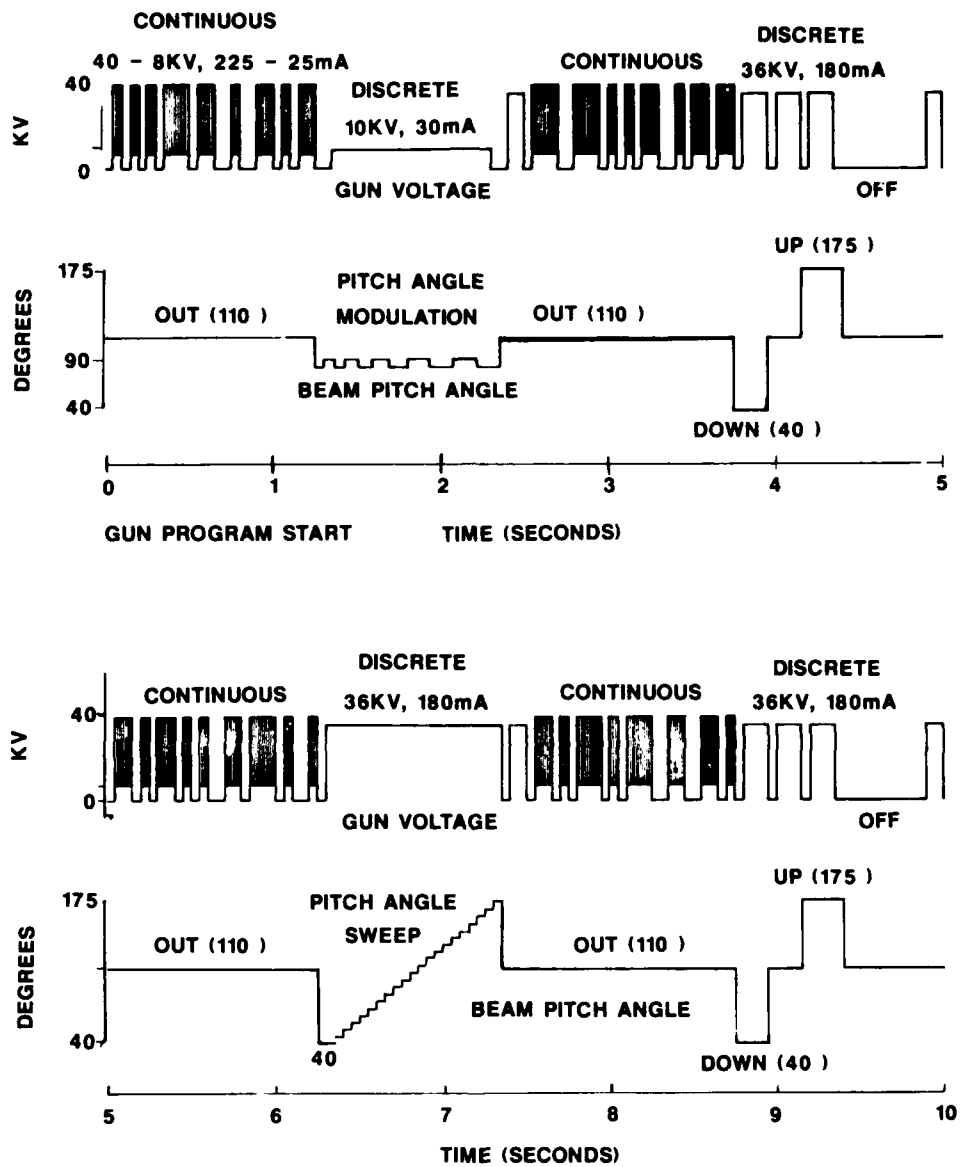

Figure 5. The 10-Second, Programed Electron Beam Emission Sequence. This sequence was repeated from beam turn-on at 179 s of the flight through re-entry at 500 s. The various accelerator modes, as well as the beam injection energies and pitch angles are explained in the text.

inhibit the accelerator convertor for 300 ms if the primary current exceeded 100A. It did not, however affect the precise 10 s repetition rate of the programmer. This inhibit circuit did save the drive system from three potential failures during flight when breakdowns occurred within the gun.

Besides the electron beam accelerator the MAIN payload carried a tethered probe to measure the electric potential of the sheath around MAIN during beam operations, a set of photometers, a complement of Geiger-Mueller tubes, a bipolar, surface-current monitor and two electrostatic analyzers (ESA).

Near apogee (279 s) the small tethered probe was ejected from MAIN toward magnetic north at a relative velocity of 1.5 m/s. The tether probe was biasable current collector of 544 cm² area that was connected to the MAIN payload by a wire and a 10⁷ Ohm resistor. It was designed to measure potential differences in the plasma sheath around the beam-emitting MAIN of up to 5kV.

The GM tube instruments were designed primarily to look for evidence of electrons having been accelerated during a subsidiary experiment with the HIPAS HF wave emitter.⁵ The two ESAs on board the MAIN payload had apertures looking up the magnetic field lines. The instruments were designed to measure the flux of return current and secondary electrons in the energy range of 2 to 2000 eV. Their geometric factors of 4.6×10^{-6} and 5.7×10^{-4} cm²-ster differed by a ratio of about 100. Each ESA had two non-synchronous modes of scanning, 3 and 100 ms/step.

3. MAIN PAYLOAD POTENTIAL VARIATIONS

The altitude versus time trajectory of the ECHO-7 flight is plotted in Figure 6. The electron beam system operated between 179 s (250 km) on the upleg to 500 s (90 km) on the downleg. During these operations the MAIN spacecraft experienced three distinct anomalies. The first occurred at 260 s when telemetry counters of the ESAs failed. The second occurred at 283 s, approximately 4 seconds after tether deployment. In the course of these events the +15 V power convertor failed, causing the loss of data from the tether, a scintillator electron detector and a photometer. At the same time, the electron gun experienced a current surge that activated the safety circuit to shut down operations for 300 ms. The third occurred at 325 s when the MAIN telemetry encoder failed. In spite of the loss of telemetry from MAIN, data from the TV cameras on the ground and on the PDP assured us that the gun and ACS operations continued as programmed. All systems, including telemetry, worked perfectly throughout the entire mission on the NOSE, PDP and EPP sub-payloads.

For the remainder of this section we consider the response of MAIN's potential during electron beam operations by examining measurements from the tether during the period 282 - 284 s, which includes the second anomaly. In the top three panels of Figure 7 we have plotted outputs from the ACS jet nozzle monitors. These are turned off except for a 20 ms roll maneuver at 282.1 s and a 30 ms pitch maneuver at 283 s. The fourth panel presents the potential of tether relative to MAIN on a scale 0 to -5 kV. The fifth trace represents the return current which was measured 625 times per second. A positive excursion represents a current away from the surface of the MAIN payload. The bottom three panels give the actual and planned beam emission steps as well as the injection pitch angle.

Between 282.0 and 282.8 s the gun's program called for and delivered a sequence of 50 and 100 ms "continuous" mode bursts at a constant injection pitch angle of 110°. In the interval between 282.8 and 283.4 s the program required three 36 keV "discrete" bursts, each of 150 ms duration at pitch angles of

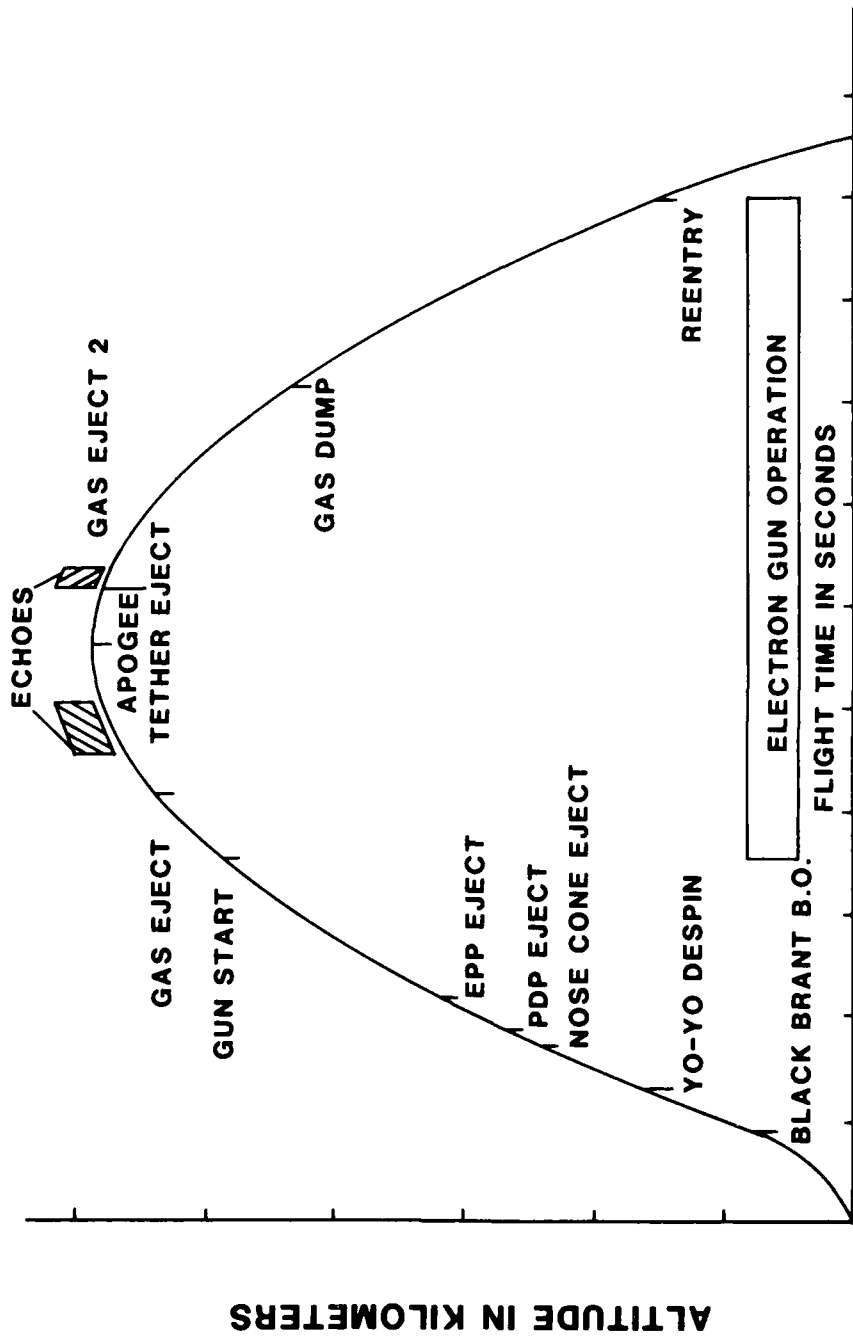

UNIVERSAL TIME 9 FEBRUARY 1988

Figure 6. Altitude versus Time Trajectory of the ECHO-7 Rocket Flight. The location of several events of interest are marked for reference.

ECHO-7

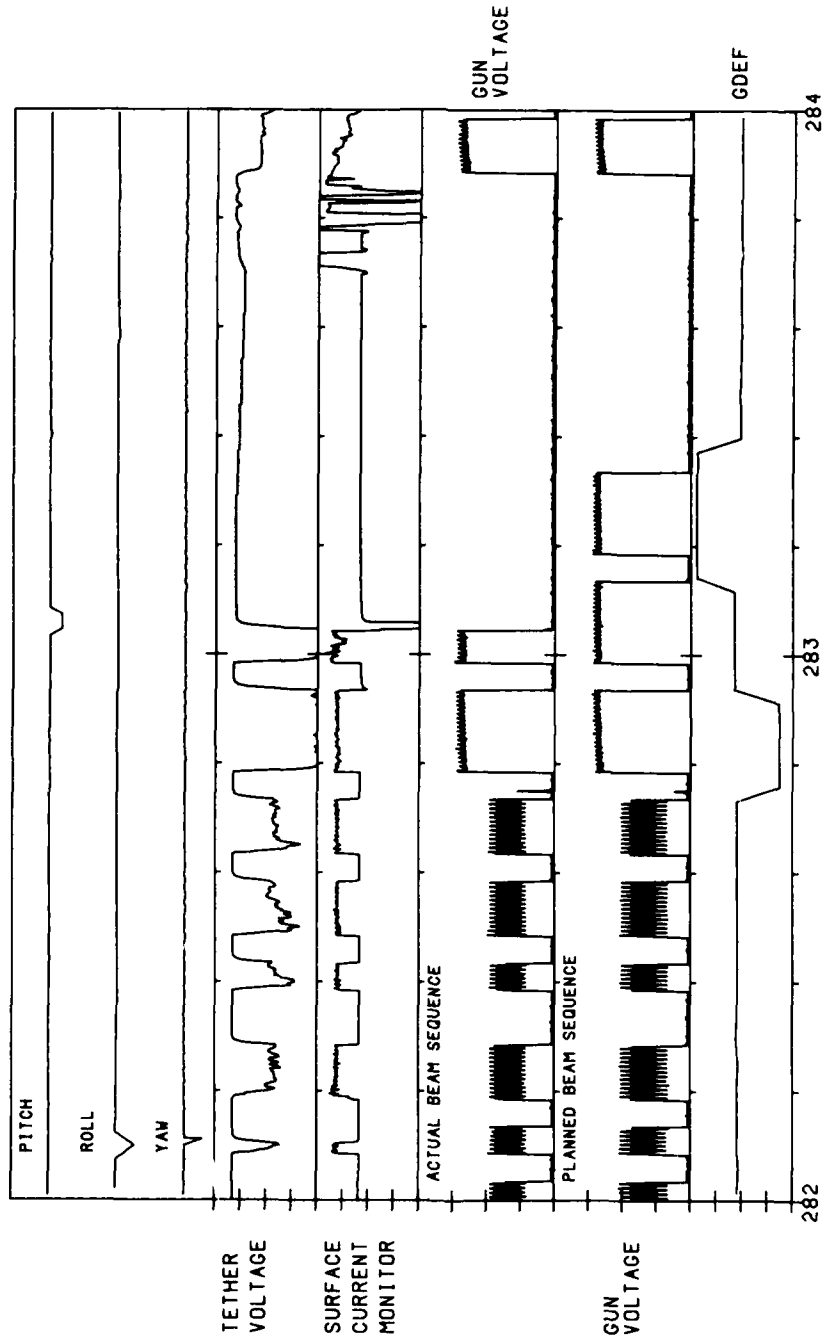

Figure 7. MAIN-Tether Data Acquired During the Interval 282 - 284 s After Launch. The top three panels give the ACS status. The fourth panel is the Tether potential with respect to MAIN. The fifth panel shows the intensity and polarity measured by the surface-current monitor. The bottom three panels represent the actual and planned beam sequences and the injection pitch angle.

40, 110, and 170°, respectively. We note that the second 36 keV burst terminated prematurely and the third did not occur at all. The next planned 36 keV discrete burst at 283.9 s took place on schedule. The termination of the second burst followed the activation of the safety circuit when the battery output current exceeded 100 A. The gun shutdown coincided with an anomalous response in the tether monitors as well as the failure of an electron detector and a photomultiplier. These instrumental failures directly follow the destruction of their +15 V power convertor.

Before analyzing the causes of these nearly simultaneous events, it is useful to reflect on the ordinary response of the tether voltages from the first second of data in Figure 7. The MAIN-Tether potential ranged between -2 and -3 kV during continuous injections, returned to zero when the beam was off and went to -5 kV during the discrete injections at 36 keV and angles of 40 and 110°. The -5 kV reading is a saturation level indicating that the potential of MAIN was above that of tether by some amount in excess of 5 kV. There is a single exception to the simple beam/potential correspondence during this interval. During the ACS roll maneuver at 282.1 s, the potential and the surface current measurements returned to nearly zero prior to beam turn-off. Evidently the presence of gas from the ACS can change the environment around MAIN to produce enough plasma to neutralize the vehicle. Prior to the first anomaly, data from tether and the ESAs taken during 10 keV discrete emissions showed vehicle potentials in the 400 to 500 V range. These immediately decreased after every ACS gas release, but did not turn the gun off or damage any internal circuitry.

The anomaly at 283 s coincides with a gas release by the ACS pitch control jet. Figure 8 is an expanded plot of data retrieved in the 53 ms after 283.02 s. Data from the surface current monitor show a polarity reversal, about 10 ms after the nozzle opened, as the first indication of a change in the local current system. The electron gun turned off about 2 ms later. Only then did the Tether voltage rise from -5 kV toward its zero level.

4. A SIMPLE ANOMALY MODEL

It is our contention that the sensor failures on MAIN are due to the effects of rapid changes in the ground potential subsequent to ionization of the nitrogen gas cloud released by the ACS.^{4,7,8,9} Data presented in Figure 7 show that during beam operations, the MAIN payload was charged to high potentials relative to the ambient plasma. This left the payload/environment system in a raised energy state in which the ECHO-7 beam could, and indeed did, operate safely. The introduction of large quantities of neutral gas into the electrostatic sheath around MAIN disrupted an unstable state of

-
7. Linson, L.M. (1983) The Importance of Neutrals, Transient Effects and the Earth's Magnetic Field on Sheath Structure. In *Proceedings of the Air Force Geophysics Laboratory Workshop on Natural Charging of Large Space Structures in Near Earth Polar Orbit: 14-15 September 1982*, AFGL-TR-83-0046, ed. by Sagalyn, R.C., Donatelli, D.E., and Michael, I., 283 - 292, ADA134894.
 8. Lai, S.T., Cohen, H.A., Bhavnani, K.H., and Tautz, M. (1985) Sheath Ionization Model of Beam Emissions from a Large Spacecraft, *Spacecraft Environmental Interactions Technology - 1983*, NASA CP-2359, AFGL TR-85-0018, 253 - 262, ADA202020.
 9. Cooke, D.L. and Katz, I. (1988) Ionization-Induced Instability in an Electron Collecting Sheath, *J. Spacecraft and Rockets* **25**:132-138.

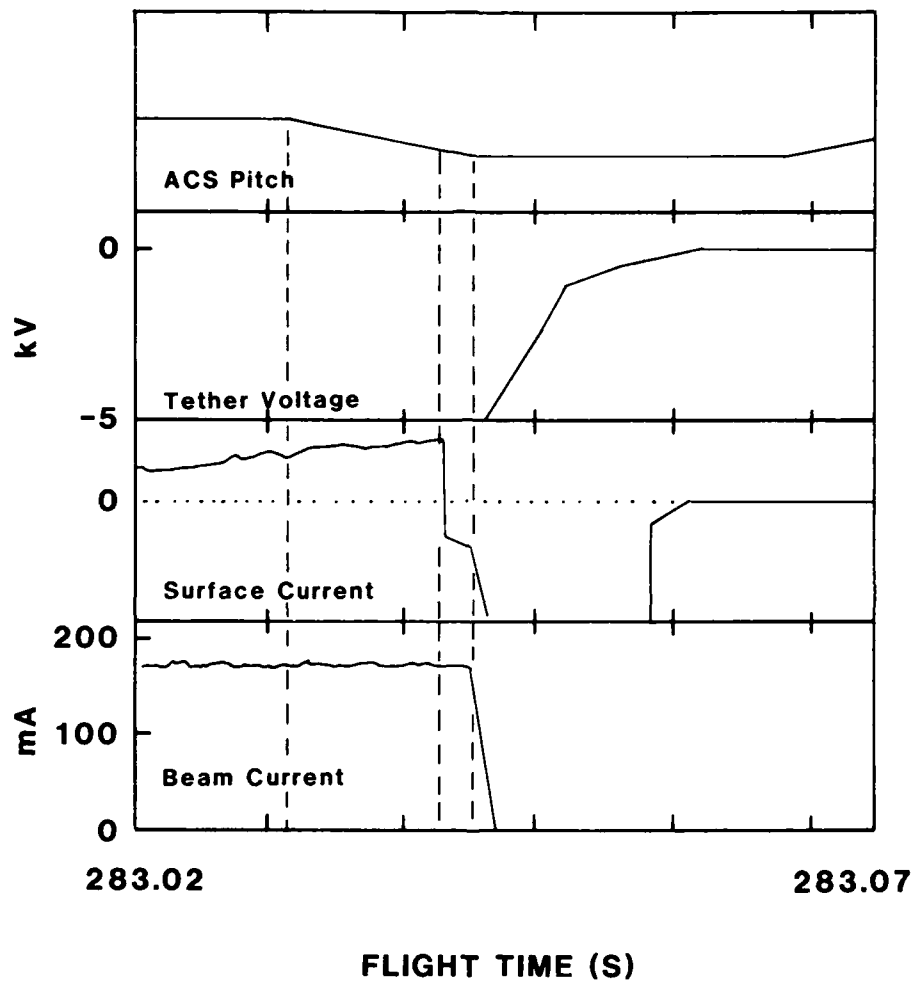

Figure 8. High Resolution Representation of Data Shown in Figure 7 During 53 ms Near the Time of Gun Shutdown

equilibrium. In the first example of an ACS gas release at 282.1 s the potential between Tether and MAIN rapidly increased from -2.5 kV to nearly 0 V. In the second case, with MAIN raised more than 5 kV above Tether at the time of the gas release, an upset followed.

The initial burst from an ACS gas jet nozzle into space is highly directed to provide the required, corrective impulse to the payload. Gas is released at a rate of about 10^{23} N₂ molecules per second. Thus, the released gas is dense and highly collisional. Depending on the exact geometry of the nozzle a portion of the emitted gas expands freely in the relative vacuum of the ionosphere to envelop MAIN.

Just prior to the ACS corrective maneuver at 283 s, the 36 keV, 180 mA beam emission charged MAIN to greater than 5 kV with respect to the background plasma. The enveloping gas cloud must interact with beam and/or return-current electrons in the sheath⁷ around MAIN to produce some unspecified amount of additional, local ionization. The new plasma created in the sheath is made up of cold electrons and N₂ ions. The electrons, having much greater mobility along magnetic field lines than the heavy ions, react very quickly to the electric fields in which they find themselves. The response time of heavy, nitrogen molecular ions is much slower.

We have examined two models for vehicle neutralization during neutral gas releases. These we referred to as the "volumetric ionization" (VI) and the "sheath instability" (SI) models. Both models predict vehicle neutralization and a shutdown of the electron gun on ECHO-7. However, they require quite different degrees of neutral gas ionization and predict different vehicle responses.

The VI model postulates that as the neutral cloud envelops MAIN, energetic electrons ionize a large fraction of the neutrals. The newly created electrons in the cloud are accelerated to the positively charged MAIN. The time of flight would be in the order of microseconds. On this time scale the ions cannot move significantly. With more electrons striking the vehicle than are necessary to neutralize the beam current, the vehicle potential would then swing negative, attracting nitrogen ions to the vehicle surface. Some ions impact the surface at the electron gun aperture.

The SI model was developed by Cooke and Katz⁹ to explain the dynamical effects of introducing a small number of ions into the sheath of an electron collecting probe. Initially the potential is assumed to monotonically decrease with distance from the probe. If the number of positive ions introduced into the sheath remains below some critical level, typically 1 or 2 percent of the total number of neutrals, the potential continues to decrease monotonically, but the sheath expands as the positive ions accelerate away from the probe. When the number of positive ions in the sheath exceeds the critical level, the potential distribution in the sheath becomes non-monotonic due to the development of a virtual anode. The virtual anode is unstable and expands outward from the vehicle. Some cold ions become trapped between the probe and the virtual anode. These ions have access to the surface of the vehicle even though the vehicle potential relative to plasma ground is still highly positive. Applied to the case of ECHO-7, sheath ions could access the electron gun aperture while the MAIN to Tether potential is still positive. In fact, the Tether potential would not rise until after the virtual anode swept past it.

The shutdown of the electron gun is evidence that positive ions indeed had access to the surface of MAIN subsequent to the ACS release. During laboratory testing of the electron gun, prior to flight, we found that the presence of positive ions in the cathode chamber increased its perveance. For a given beam energy the gun tried to emit more current. At the highest beam energies the gun demanded a higher current in the primary coil than could be sustained safely. Thus, the gun is ordered to shut

down. Note that at 283 s the electron beam was emitting at 110° with the deflection magnet turned off, allowing impacting ions free access to the gun's interior.

In the VI model the ions get to MAIN's surface only after a large number of newly created electrons have caused the vehicle potential to overshoot and become negative for a brief period of time. In the SI model, applied to the present case, the vehicle potential was neutralized because the gun was turned off. In either explanation, the power converter could not stand up to transient currents induced by the rapidly changing vehicle potential to which it was grounded.

The high resolution data presented in Figure 8 seem to favor the SI model interpretation. Although this explanation appears more probable, it is not definitive at this time. Our present uncertainty derives from the relative slowness of the measurements from the sensors on MAIN. Recall that electron time of flight across the sheath is under a microsecond, while readings from the surface current monitor was at a rate of 625 Hz. For the sake of measurement-stability the response of the Tether voltage monitor was purposely made even slower.

We have looked for experimental evidence of potential overshoots in data collected during the 1-second long, 10 keV discrete beam operations, prior to the anomaly, in which there were ACS corrective maneuvers. The surface current monitor measured currents away from MAIN that first rose as increased fluxes of electrons reached the vehicle's surface, then decreased and changed sign indicating a current toward MAIN, before returning to the original polarity. Although the deflection magnet was turned off during these 110° pitch angle emissions, the emitted current was low. Thus, even with an increased perveance the safety circuit was not activated.

The roles of the high charging state and the deflection magnet are consistent with the two other cases in which the safety circuit interrupted beam operations during the flight. Each of these occurred while the beam program called for a discrete emission at 36 keV. In one case the pitch angle was fixed at 110° ; in the other, the pitch angle was being swept through 90° . Thus, the deflection magnetic field strength was either weak or zero. There were many ACS corrective maneuvers during 36 keV emissions at other pitch angles, but none of these resulted in a beam shutdown.

In the light of our experience with ECHO-7, the suggestion of Banks et al⁴ that neutral gas emissions provide a safe method for ensuring that energetic electron beams get away from the emitting body must be qualified. First, the gas emissions should be continuous so that the vehicle potential does not undergo very rapid changes. Second, if the gas releases are intermittent, a deflection magnet can protect the electron gun from the unwanted intrusion of positively charged ions.

References

1. Cohen, H.A., Adamo, R.C., Aggson, T., Chesley, A.L., Clark, D.M., Dameron, S.A., Delroy, D.E., Fennell, J.F., Gussenhoven, M.S., Hanser, F.A., Hall, D., Hardy, D.A., Huber, W.B., Katz, I., Koons, H.C., Lai, S.T., Ledley, B., Mizera, P.F., Rubin, A.G., Schnulle, G.W., Saffekos, N.A., Tautz, M.F., and Whipple, E.C. (1981) P78-2 Satellite and Payload Responses to Electron Beam Operations on March 30, 1979, in *Spacecraft Charging Technology 1980*, NASA CP 2182; AFGL-TR-81-0270, ed. by Stevens, N.J. and Pike, C.P., ADA114426, 509 - 559.
2. Maehlum, B.N., Troim, J., Maynard, N.C., Denig, W.F., Friedrich, M., and Torkar, K.M. (1988) Studies of the electrical charging of the tethered electron accelerator mother-daughter rocket MAIMIK, *Geophys. Res. Lett.* **15**: 725-728.
3. Massey, D.E., Williams, C.P., Ransone E.D., Eddy, T.E., and Monson, S.J. (1987) *Black Brant 36.004 UE Final Failure Report*, NASA Goddard Space Flight Center, Wallops Flight Facility.
4. Banks, P.M., Gilchrist, B.E., Neubert, T., Bush, R.I., Williamson, P.R., Meyers, N., and Raitt, W.J. (1988) Rocket observations of electron beam experiments with vehicle charging neutralized by neutral gas plumes, XXVII COSPAR, 18 - 29 July 1988, Espoo Finland, Topical Meeting on Active Experiments, 343.
5. Winckler, J.R., Malcolm, P.R., Arnoldy, R.L., Burke, W.J., Erickson, K.N., Ernstmeyer, J., Franz, R.C., Hallinan, T.J., Kellogg, P.J., Lynch, K.A., Monson, S.J., Murphy, G.P., and Nemzek, R.J. (1989) ECHO-7: An Electron Beam Experiment in the Magnetosphere, (Submitted for Publication) *EOS: Trans. Amer. Geophys. U.*
6. Pierce, J.R. (1949) *Theory and Design of Electron Beams*, D. Van Nostrand Co., New York, 167 - 187.
7. Linson, L.M. (1983) The Importance of Neutrals, Transient Effects and the Earth's Magnetic Field on Sheath Structure, in *Proceedings of the Air Force Geophysics Laboratory Workshop on Natural Charging of Large Space Structures in Near Earth Polar Orbit: 14-15 September 1982*, AFGL-TR-83-0046, ed. by Sagalyn, R.C., Donatelli, D.E., and Michael, I., 283 - 292, ADA134894.
8. Lai, S.T., Cohen, H.A., Bhavnani, K.H., and Tautz, M. (1985) Sheath Ionization Model of Beam Emissions from a Large Spacecraft, *Spacecraft Environmental Interactions Technology - 1983*, NASA CP-2359, AFGL TR-85-0018, 253 - 262, ADA202020.

9. Cooke, D.L. and Katz, I. (1988) Ionization-Induced Instability in an Electron Collecting Sheath, *J. Spacecraft and Rockets* **25**:132-138.