

DTIC FILE COPY

2

MISCELLANEOUS PAPER HL-89-4



US Army Corps of Engineers

SCOUR PROTECTION FOR MORGANTOWN DAM MONONGAHELA RIVER, WEST VIRGINIA

Hydraulic Model Investigation

by

John E. Hite, Jr.

Hydraulics Laboratory

DEPARTMENT OF THE ARMY

Waterways Experiment Station, Corps of Engineers
3909 Halls Ferry Road, Vicksburg, Mississippi 39180-6199

AD-A212 483

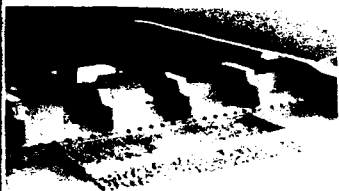
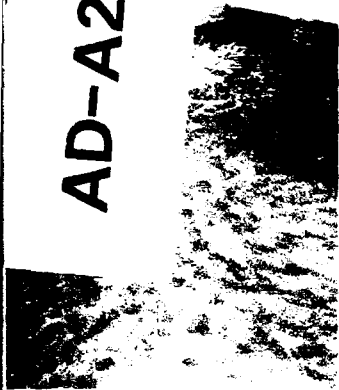

DTIC
ELECTE
SEP 18 1989
S B D
CB

August 1989

Final Report

Approved For Public Release. Distribution Unlimited



Prepared for US Army Engineer District, Pittsburgh
Pittsburgh, Pennsylvania 15222-4186

89 9 18 026

Unclassified

SECURITY CLASSIFICATION OF THIS PAGE

REPORT DOCUMENTATION PAGE				Form Approved OMB No. 0704-0188	
1a. REPORT SECURITY CLASSIFICATION Unclassified		1b. RESTRICTIVE MARKINGS			
2a. SECURITY CLASSIFICATION AUTHORITY		3. DISTRIBUTION / AVAILABILITY OF REPORT			
2b. DECLASSIFICATION / DOWNGRADING SCHEDULE		Approved for public release; distribution unlimited			
4. PERFORMING ORGANIZATION REPORT NUMBER(S) Miscellaneous Paper HL-89-4		5. MONITORING ORGANIZATION REPORT NUMBER(S)			
6a. NAME OF PERFORMING ORGANIZATION USAEWES Hydraulics Laboratory		6b. OFFICE SYMBOL (If applicable) CEWES-HS-L	7a. NAME OF MONITORING ORGANIZATION		
6c. ADDRESS (City, State, and ZIP Code) 3909 Halls Ferry Road Vicksburg, MS 39180-6199			7b. ADDRESS (City, State, and ZIP Code)		
8a. NAME OF FUNDING / SPONSORING ORGANIZATION USAED, Pittsburgh		8b. OFFICE SYMBOL (If applicable)	9. PROCUREMENT INSTRUMENT IDENTIFICATION NUMBER		
8c. ADDRESS (City, State, and ZIP Code) 1000 Liberty Avenue Pittsburgh, PA 15222-4186		10. SOURCE OF FUNDING NUMBERS			
		PROGRAM ELEMENT NO	PROJECT NO	TASK NO	WORK UNIT ACCESSION NO
11. TITLE (Include Security Classification) Scour Protection for Morgantown Dam, Monongahela River, West Virginia; Hydraulic Model Investigation					
12. PERSONAL AUTHOR(S) Hite, John E., Jr.					
13a. TYPE OF REPORT Final report		13b. TIME COVERED FROM _____ TO _____		14. DATE OF REPORT (Year, Month, Day) August 1989	15. PAGE COUNT 90
16. SUPPLEMENTARY NOTATION Available from National Technical Information Service, 5285 Port Royal Road, Springfield, VA 22161.					
17. COSATI CODES			18. SUBJECT TERMS (Continue on reverse if necessary and identify by block number)		
FIELD	GROUP	SUB-GROUP	Hydraulic models	Riprap	
			Monongahela River	Scour	
			Navigation dam		
19. ABSTRACT (Continue on reverse if necessary and identify by block number) Morgantown Lock and Dam is a navigation project on the Monongahela River 102 miles from the mouth of the river in West Virginia. The project consists of a spillway section with six 60-ft-wide gates, a modified flip-type stilling basin for energy dissipation, and an 84- by 600-ft lock. Model tests were conducted on a 1:25-scale model of the spillway and stilling basin to determine sizing and configuration of materials necessary to protect the area immediately downstream from the stilling basin from additional scour. Numerous types of scour protection plans were tested from graded riprap to a secondary stilling basin. Initially, a scour protection plan consisting of a secondary stilling basin was developed for flow conditions with a normal upper pool, minimum project tailwater, and one gate fully open. These conditions were representative of those that could occur during ice or debris passage, malfunction of a gate, a navigation accident, or vandalism. This plan was not feasible since it would be too expensive and would require dewatering of the					
20. DISTRIBUTION / AVAILABILITY OF ABSTRACT <input checked="" type="checkbox"/> UNCLASSIFIED/UNLIMITED <input type="checkbox"/> SAME AS RPT <input type="checkbox"/> DTIC USERS			21. ABSTRACT SECURITY CLASSIFICATION Unclassified		
22a. NAME OF RESPONSIBLE INDIVIDUAL			22b. TELEPHONE (Include Area Code)		22c. OFFICE SYMBOL

Unclassified

SECURITY CLASSIFICATION OF THIS PAGE

19. ABSTRACT (Continued).

project to construct. Tests were then conducted to develop scour protection consisting of barges filled with riprap and grouted. Several designs were tested, none of which provided satisfactory flow conditions and adequate scour protection. The model results provided options of the scour protection desired based on certain hydraulic flow conditions.

Unclassified

SECURITY CLASSIFICATION OF THIS PAGE

PREFACE

The model investigation reported herein was authorized by the Headquarters, US Army Corps of Engineers (USACE), on 19 December 1983 at the request of the US Army Engineer District, Pittsburgh (ORP).

The studies were conducted by personnel of the Hydraulics Laboratory (HL), US Army Engineer Waterways Experiment Station (WES), during the period September 1985 to March 1987 under the direction of Messrs. F. A. Herrmann, Jr., Chief, HL; J. L. Grace, Jr., former Chief of the Hydraulics Structures Division (HSD), HL; and G. A. Pickering, Chief, HSD. The tests were conducted by Messrs. T. E. Murphy, Jr., and J. E. Hite, Jr., Locks and Conduits Branch, HSD, under the supervision of Mr. J. F. George, Chief of the Locks and Conduits Branch. This report was prepared by Mr. Hite.

The model was constructed by Messrs. Robert L. Blackwell, Melvin L. Bolden, and Edward A. Case of the Model Shop, Engineering and Construction Services Division (E&CSD), WES, under the supervision of Mr. Sidney J. Leist, Chief of the Model Shop; and Messrs. Charles L. Brown, Avery L. Harris, Arthur J. Lee, Willie R. Patterson, and Willie C. Thomas and Ms. S. Belfield under the supervision of Messrs. Clarence Drayton, Jr., and George White, all of the Model Construction Section, E&CSD.

Messrs. Bruce McCartney, USACE; Laszlo Varga, US Army Engineer Division, Ohio River; and Ed Kovanic, Robert Schmitt, Joe Coletti, Walt Leput, and Ray Povirk, ORP, visited WES during the course of the model study to observe model operation and correlate results with design studies.

COL Dwayne G. Lee, CE, was the Commander and Director of WES. Dr. Robert W. Whalin was Technical Director.

Accession For	
NTIS GRA&I	<input checked="" type="checkbox"/>
DTIC TAB	<input type="checkbox"/>
Unannounced	<input type="checkbox"/>
Justification	
By	
Distribution/	
Availability Codes	
Dist	Avail and/or
A-1	Special



TABLES OF CONTENTS

	<u>Page</u>
PREFACE.....	1
CONVERSION FACTORS, NON-SI TO SI (METRIC) UNITS OF MEASUREMENT....	3
PART I. INTRODUCTION.....	4
Background.....	4
Purpose of the Model Study.....	4
PART II: THE MODEL.....	7
Description.....	7
Model Appurtenances.....	7
Scale Relations.....	7
PART III: TESTS AND RESULTS.....	10
Riprap Protection Plans.....	10
Scour Protection Plans.....	11
PART IV: SUMMARY AND RECOMMENDATIONS.....	20
PHOTOS 1-40	
PLATES 1-27	

CONVERSION FACTORS, NON-SI TO SI (METRIC) UNITS OF MEASUREMENTS

Non-SI units of measurement used in this report can be converted to (SI) metric units as follows:

<u>Multiply</u>	<u>By</u>	<u>To Obtain</u>
cubic feet	0.02831685	cubic metres
feet	0.3048	metres
miles (US statute)	1.609347	kilometres
pounds (mass)	0.4535924	kilograms

SCOUR PROTECTION FOR MORGANTOWN DAM
MONONGAHELA RIVER, WEST VIRGINIA
Hydraulic Model Investigation

Part I: INTRODUCTION

Background

1. Morgantown Dam is located in West Virginia 102 miles* from the mouth of the river (Figure 1). The project consists of a spillway section with six tainter gates 60 ft wide, a modified flip-type stilling basin, and an 84- by 600-ft-wide navigation lock (Figure 2).

2. The project was constructed between 1948 and 1950. Over the years scour has occurred downstream from the stilling basin in what was originally believed to be competent rock and there is concern that additional scour may have adverse impacts on the structural integrity of the structure. Soundings taken over the years indicate the depth of scour is approaching the foundation elevation in some areas below the structure.

Purpose of the Model Study

3. The purpose of the model study was to develop a scour protection plan that would repair the area immediately downstream from the stilling basin and prevent future scouring of this area. A plan that would provide protection for operations with normal upper pool, minimum project tailwater, and one gate fully open was desired.

* A table of factors for converting non-SI units of measurement to metric (SI) units is presented on page 3.

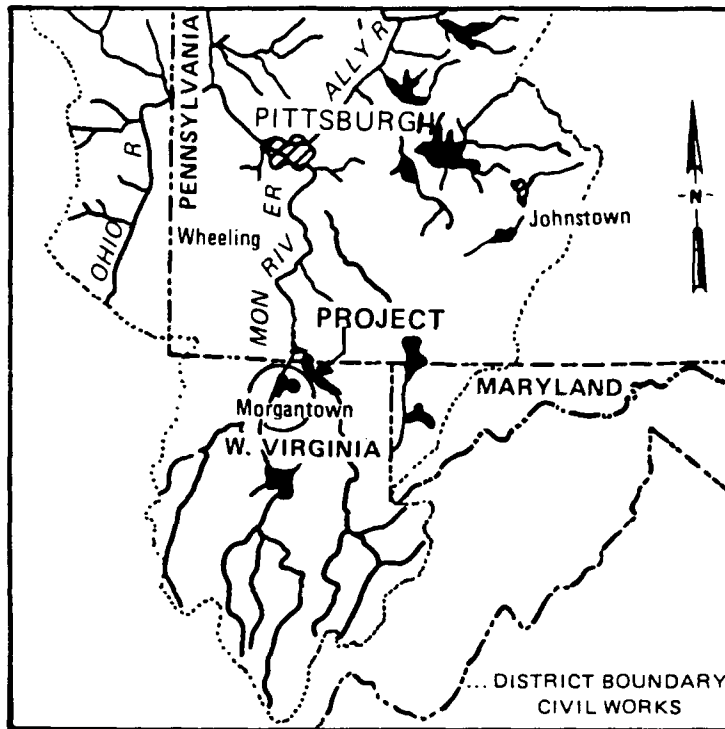

VICINITY MAP

SCALE

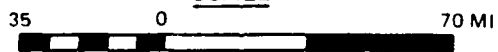
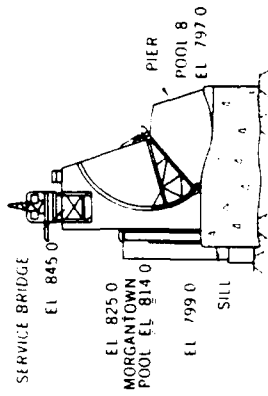
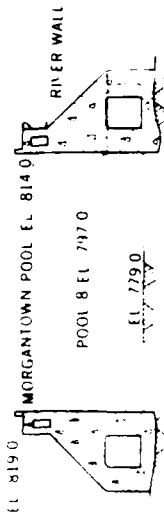

Figure 1. Vicinity map



GATE SECTION



SECTION THROUGH LOCK

MONONGALIA CO
WEST VIRGINIA

CONGRESSIONAL
DISTRICT NO 2

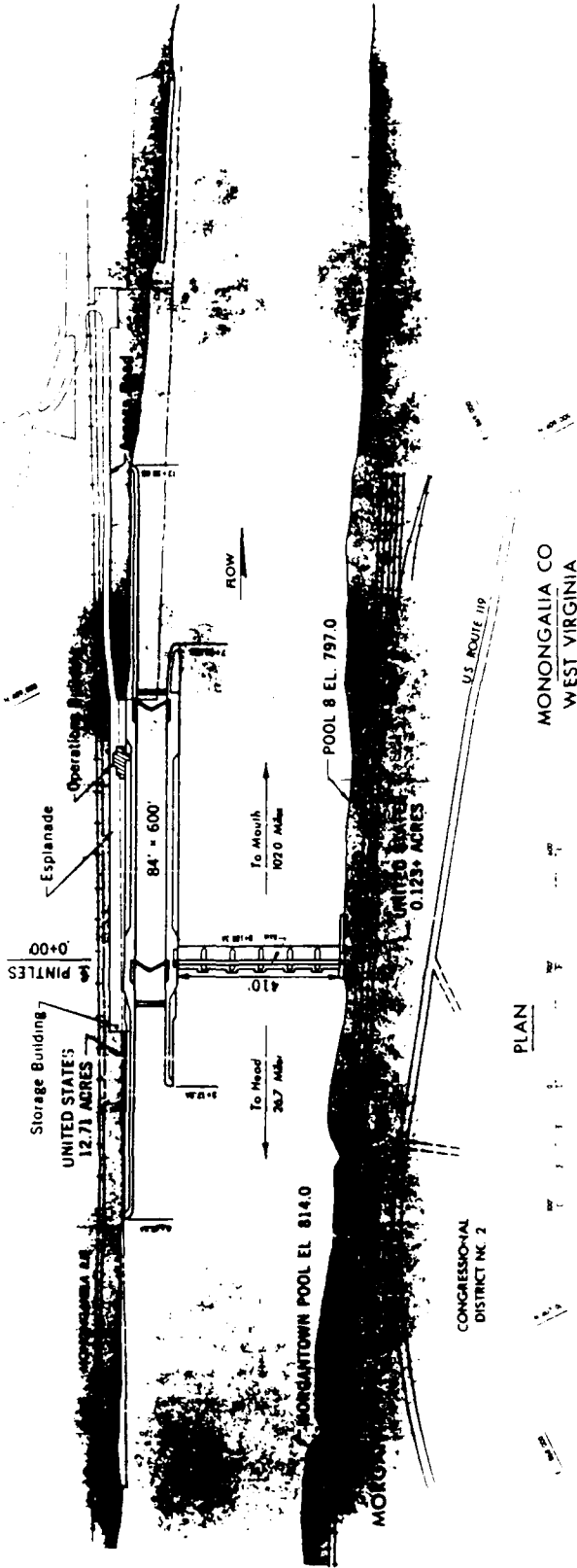

Figure 2. Plan and section views

PART II: THE MODEL

Description

4. The model (Figure 3) was constructed to an undistorted scale of 1:25 and reproduced approximately 500 ft of topography upstream from the structure, the structure including the six spillway gates, the stilling basin, and a portion of the navigation lock, the proposed scour protection plan, and approximately 1,000 ft of the exit channel. The spillway, gates, and stilling basin apron, were fabricated of sheet metal and the lock and stilling basin elements were constructed of wood. The upstream topography was molded in sand and cement mortar to sheet metal templates and the exit channel was molded in sand.

Model Appurtenances

5. Water used in operation of the model was supplied by a circulating system. Discharges in the model, measured with venturi meters installed in the inflow lines, were baffled when entering the model. Water-surface elevations and soundings over the sand and riprap beds were measured with point gates. Velocities were measured with pivot tubes mounted to permit measurement of flow from any direction and at any depth. The tailwater in the lower end of the model was maintained at the desired depth by means of an adjustable tailgate. Different designs, along with various flow conditions, were recorded photographically.

Scale Relations

6. The accepted equations of hydraulic similitude, based on the Froundian criteria, were used to express mathematical relations between the dimensions and hydraulic quantities of the model and prototype. General relations for the transference of model data to prototype equivalents are presented in the following tabulation:

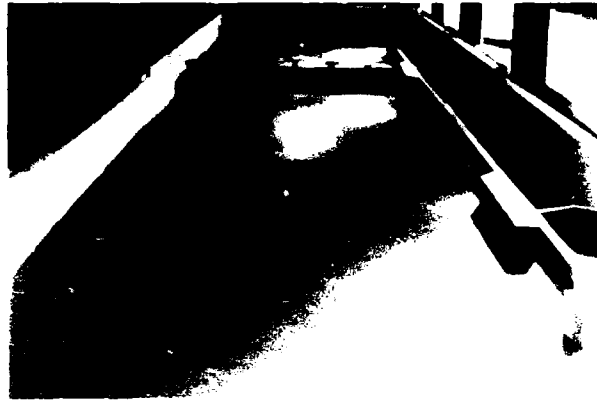

a. Looking upstream

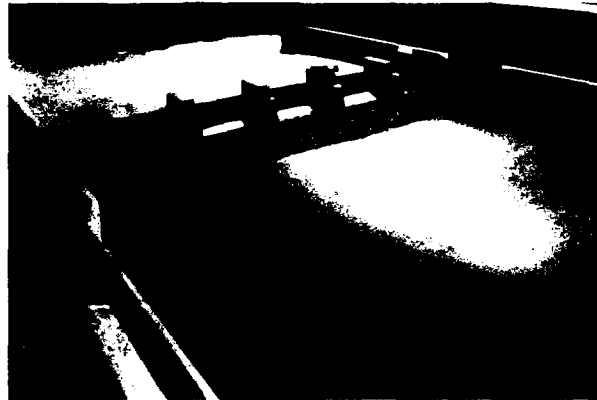

b. Side view



c. Looking downstream

Figure 3. General views of model

<u>Characteristic</u>	<u>Dimension*</u>	<u>Model:Prototype</u>
Length	L_r	1:25
Area	$A_r = L_r^2$	1:625
Velocity	$V_r = L_r^{1/2}$	1:5
Discharge	$Q_r = L_r^{5/2}$	1:3,125
Volume	$V_r = L_r^3$	1:15,625
Weight	$W_r = L_r^3$	1:15,625
Time	$T_r = L_r^{1/2}$	1:5

* Dimensions are in terms of length.

Because of the nature of the phenomena involved, certain model data can be accepted quantitatively, while other data are reliable only in a qualitative sense. Measurements in the model of discharges, water-surface elevations, velocities, and resistance to displacement of riprap material can be transferred quantitatively from model to prototype by means of the above scale relations. Evidence of scour of the model sand bed, however, is to be considered only as qualitatively reliable since it has not yet been found possible to reproduce quantitatively in a model the relatively greater extent of erosion that occurs in the prototype with fine-grained bed material. Data on scour tendencies provided a basis for determination of the relative effectiveness of the different designs and indicated the areas most subject to attack.

PART III: TESTS AND RESULTS

Riprap Protection Plans

7. As stated previously, the purpose of the model tests was to develop a scour protection plan for various operating scenarios. It was desirable to develop a plan that would prevent scour with conditions that could result from malfunction or misoperation of a gate, a navigation accident or some debris and/or ice passage conditions. The most severe hydraulic condition is considered to be one gate fully open with full pool and minimum project tailwater. This is a very extreme condition and normally the original stilling basin must be designed for this operating scenario if scour downstream from the structure is to be prevented. For this structure, ice and debris can be passed under the gate with gate openings from 6 to 8 ft with normal project tailwater. Thus, several tests were conducted with these conditions.

Type 1 riprap protection plan

8. Initial tests were conducted to determine the stability of the type 1 riprap plan shown in Plate 1 for single gate operation with normal upper pool, el 814,* and minimum tailwater, el 797. The gradation of the type 1 riprap is shown in Plate 2. The plan consisted of a 54-in.-thick blanket of riprap with an average D_{50} size stone of 27 in., offset 2 ft below the basin apron, and sloped downward on a 1V on 4.5H to el 782. This plan was tested due to the availability of the size stone and the plan had performed satisfactorily for other projects. The first test was conducted with gate 3 opened 8 ft. The tailwater was gradually lowered beginning at el 807 in an attempt to reach the minimum elevation of 797, but failure occurred when the tailwater reached el 799.

9. A test was then conducted for 5 hr (prototype) with normal upper pool, gate 3 open 8 ft, and a normal tailwater elevation of 805.4 to determine the stability of the type 1 riprap plan under normal operating conditions.

*All elevations (el) and stages cited herein are in feet referred to the National Geodetic Vertical Datum (NGVD)

All tests were conducted using gate 3, which was one of the center-bays of the model, unless stated otherwise. After completion of the test, the model was drained slowly and results indicated that the type 1 riprap plan had failed. Another test was conducted with normal upper pool and tailwater, and a 6-ft gate opening, for a duration of 5 hr. The results shown in Photo 1 indicate riprap was displaced throughout the entire blanket and this was considered failure since displacement occurred so quickly. Flow conditions for normal operating conditions with 6- and 8-ft gate openings are shown in Photos 2 and 3, respectively. Supercritical flow exits the existing basin and plunges through the tailwater severely attacking the area below the basin and creating undesirable flow conditions for these gate settings and tailwaters.

Type 2 riprap protection plan

10. The type 1 riprap plan was replaced with the type 2 riprap plan shown in Plate 3. This plan consisted of 4- to 5-ft-diameter stones placed in the same manner as the type 1 riprap plan. The type 2 riprap plan was tested for 5 hr (prototype) with normal operating conditions for a 6-ft gate opening. The plan remained stable and results from this test are shown in Photo 4. The weight of the 4- to 5-ft-diameter stones was sufficient to resist displacement with this flow condition. A test was then conducted with normal upper pool, a 6-ft gate opening and gradually lowering the tailwater in an attempt to reach the minimum tailwater elevation. The type 2 riprap plan failed when the tailwater elevation reached 797.8, 0.8 ft higher than the minimum, as shown in Photo 5. This procedure was repeated for a 3-ft gate opening and the riprap again failed when the tailwater reached el 797.8. The type 2 riprap plan was then tested to determine if it would remain stable for 5 hr of operation with normal upper pool and tailwater (799.7) and a 3-ft gate opening. The riprap was unstable for these conditions and had the previous tests with 6- and 8-ft gate openings been conducted for 5 hr, failure probably would have occurred for tailwater elevations higher than 797.8.

Scour Protection Plans

Type 3 scour protection plan

11. Since riprap would not provide adequate protection for the conditions previously described, tests were conducted using barges filled with

grouted riprap placed below the stilling basin followed by a 50-ft length of riprap with an average D_{50} size stone of 27 in. The first of this type design was designated as the type 3 scour protection plan and is shown in Plate 4. The term "scour protection plan" is used to identify this type of design because the plan consists of protection materials other than the use of riprap only. The type 3 scour protection plan was tested with normal upper pool, a 6-ft gate opening, and a gradual lowering of the tailwater to reach the minimum elevation of 797. Riprap was placed immediately downstream from the barges and provided a basis for comparing the severity of the turbulence in that area. The riprap placed below the barge failed when the tailwater reached 798.3, as shown in Photo 6. The flow jet swept through the basin and across the barge, then plunged through the tailwater and attacked the riprap causing failure.

Type 4 scour protection plan

12. The type 4 scour protection plan, shown in Plate 5, was tested next. Two 26-ft-wide barges were placed downstream and adjacent to the end of the stilling basin with a 3-ft-high sill placed at the end of the downstream barge followed by 4- to 5-ft-diameter stones placed on a 1V on 4.5H downward slope. The intent of this plan was to attempt to provide a secondary type stilling basin to dissipate energy in the flow exiting the existing structure. The top of the barge could not be lowered to a desirable depth due to the elevation of the streambed below the structure, which is approximately 782. The riprap protection placed downstream of the barges failed when tests were conducted with normal upper pool and tailwater conditions for a 6-ft gate opening. The flow swept across the barges, was deflected upward by the sill and then plunged through the tailwater causing the rock to fail.

Type 5 scour protection plan

13. The 3-ft high sill was removed from the type 4 plan to determine the effect on the flow conditions exiting the barge. This was the type 5 scour protection plan. A test was conducted with normal upper pool and tailwater conditions for a 6-ft gate opening and the riprap protection downstream of the barge failed again.

Type 6 scour protection plan

14. The top of the barges was then lowered 3.5 ft from the previous plan in an effort to improve energy dissipation. This design was designated the type 6 scour protection plan and is shown in Plate 6. A test was

conducted with normal upper pool and tailwater conditions for a 6-ft gate opening and the rock downstream of the barges was displaced shortly after the test was initiated.

Type 7 scour protection plan

15. The type 7 scour protection plan, Plate 7, consisted of placing a 26-ft-wide barge immediately downstream from the stilling basin on a 1V on 6.5H downward slope beginning at el 793, followed by a barge placed horizontally with the top of this barge at el 789. Riprap was not placed below the barges so scouring tendencies immediately downstream from the barges could be observed. A test was conducted with normal upper pool and tailwater elevations for a 6-ft gate opening. After a 5 hr (prototype) test, scour downstream was excessive and the void under the barge, Photo 7, indicated the necessity for protection placed downstream from the barges.

16. Due to the difficulties encountered with the seven previous plans, the type 7 scour protection plan was removed from the model and a non-erodible material (mixture of sand and cement) was placed in the model at el 782 for 250 ft downstream from the existing structure. Model tests were conducted to determine the characteristics of the supercritical flow exiting the structure. The area between the end of the structure and approximately 30 ft downstream was subject to the most severe attack from the flow. Flow conditions with a 3-ft, 6-ft, and full gate opening for minimum and normal tailwater conditions are shown in Photos 8 and 9, respectively. Velocities greater than 30 ft/sec were measured exiting the structure for these flow conditions. The existing tailwater conditions were not sufficient to provide the depth required for adequate energy dissipation.

Type 8 scour protection plan

17. Preceding tests revealed the magnitude of supercritical flow exiting the existing structure could only be effectively tempered by installing a secondary stilling basin below the structure. The type 8 scour protection plan was designed with a secondary stilling basin and with the existing stilling basin filled in to improve entrance conditions into the secondary stilling basin, as shown in Plate 8. Initially, no protection was placed below the basin so the scour in the exit channel could be observed. Scour in the exit channel after 5 hr of operation with normal upper pool, gate 3 open full, and minimum tailwater is shown in Photo 10. Energy dissipation in the stilling basin was considered marginal and significant scour occurred in the exit channel.

Type 9 scour protection plan

18. A 54-in.-thick blanket of riprap with an average D_{50} size stone of 27 in. was placed below the type 8 stilling basin, and was designated the type 9 scour protection plan as shown in Plate 9. The type 9 scour protection plan was tested for 5 hr with normal upper pool, gate 3 open full, and minimum tailwater. Riprap was displaced in some areas of the blanket and scour was present in the exit channel after completion of this test, as shown in Photo 11.

Type 10 scour protection plan

19. The 54-in.-thick blanket of graded riprap was replaced with 4- to 5-ft-diameter stones to form the type 10 scour protection plan shown in Plate 10. The stones in this plan remained stable during 5 hr of operation with gate 3 open full and minimum tailwater. Results from this test are shown in Photo 12.

Type 11 scour protection plan

20. Since energy dissipation in the secondary stilling basin of the types 8, 9 and 10 scour protection plans was considered marginal, the type 11 scour protection plan was developed. This design extended the apron length of the secondary basin from 58.48 ft in the type 8 scour protection plan to 72.60 ft in the type 11 scour protection plan and added a second row of baffle blocks, as shown in Plate 11. Test results after 5 hr of operation with normal upper pool, gate 3 open full, and minimum tailwater and no riprap downstream are shown in Photo 13. Energy dissipation in the secondary stilling basin was good and scour in the exit channel was reduced from the previous designs tested, as seen by comparing Photos 10 and 13.

Type 12 scour protection plan

21. A 54-in.-thick blanket of riprap with an average D_{50} size stone of 27 in. was placed below the secondary stilling basin, the type 12 scour protection plan shown in Plate 12. This design was tested and remained stable after 5 hr of operation with normal upper pool, gate 3 open full, and minimum tailwater. Results from this test are shown in Photo 14, and flow conditions with this operation are shown in Photo 15. An additional test was conducted with the upper pool raised 9.6 ft higher than normal, gate 3 open full, and minimum tailwater. This is the maximum pool elevation before flow over the lock wall occurs. The type 12 scour protection plan remained stable during 5 hr of operation with these conditions and results from this test are shown

in Photo 16. Flow conditions with this operation are shown in Photo 17. This is a most severe flow condition, and the fact that the riprap was not displaced proves the effectiveness of a secondary stilling basin. Flow conditions for gate 3, set at a 6-ft gate opening with normal upper pool and minimum tailwater are shown in Photo 18.

Type 13 scour protection plan

22. Since the secondary stilling basin performed satisfactorily, the type 13 scour protection plan shown in Plate 13 was tested in an attempt to provide a secondary basin from a barge arrangement, which would be much more economical to construct than the type 12 plan. The plan consisted of a 12-ft-deep barge filled with 6 ft of grouted riprap placed below the existing structure and followed by 4- to 5-ft-diameter stones placed on a 1V on 3H downward slope. A test was conducted for 5 hr (prototype) with gate 3 opened fully to the normal pool, el 814, and minimum tailwater, el 797. Results from the test indicated that energy dissipation in the existing basin and on top of the barge was poor and the stones below the barge were displaced by the flow plunging off the end of the barge.

Type 14 scour protection plan

23. The type 14 scour protection plan shown in Plate 14, consisted of two barges placed downstream from the existing basin and followed by 4- to 5-ft-diameter stones placed on a 1V on 3H downward slope. The plan was tested with gate 3 opened fully to the normal pool and minimum tailwater and failed in the same manner as the type 13 plan. Flow conditions during this test are shown in Photo 19 and illustrate the excessive turbulence caused by this condition.

Type 15 scour protection plan

24. A third barge was placed downstream of the second one at the same el 795 to form the type 15 scour protection plan shown in Plate 15. The plan was tested with normal upper pool, minimum tailwater and gate 3 fully opened and again the stones downstream of the last barge were displaced. Flow conditions during this test are shown in Photo 20a and indicate the jet was deflected upward by the walls of the barges and some energy was dissipated, but the stones below the barges were displaced. The stones were placed below the barge as an indicator of the turbulence occurring in this area. Flow conditions with a normal tailwater el 807.9 for gate 3 opened fully to the normal pool are shown in Photo 20b. The type 15 scour protection plan was stable for this flow condition.

Type 16 scour protection plan

25. The type 16 scour protection plan shown in Plate 16 and Photo 21 consisted of removing 6 ft of the walls between the barges in the type 14 plan. This was done in an effort to improve performance of the secondary stilling basin constructed of two barges. The plan was tested and the 4- to 5-ft-diameter stones placed below the barge were washed away. The jet was too strong to be contained in the secondary basin as shown in Photo 22.

Type 17 and 18 scour protection plans

26. The top of the wall between the barges was raised to el 792 to form the type 17 scour protection plan shown in Plate 17. The plan was tested in the same manner as the type 16 plan, but the stones failed again. A 3-ft-high sill was added to the end of the original basin as shown in Plate 18, type 18 scour protection plan, in an effort to flip the jet upward and cause it to be stilled above the sunken barges. Energy dissipation was improved, but severe turbulence still occurred and the flow plunged through the tailwater displacing the stone protection.

Type 19 scour protection plan

27. Since an improvement in energy dissipation was observed with the type 18 plan, the 3-ft sill was left in place and the downstream wall of the second barge was cut down to 6 ft, the same elevation as the grouted riprap. The center walls remained 9 ft high and 4- to 5-ft-diameter stones were placed horizontally for a distance of 25 ft. This was the type 19 scour protection plan and is shown in Plate 19. Scour in the exit channel after 5 hr of operation with gate 3 opened fully to the normal pool and a tailwater of 797 is shown in Photo 23. A few stones were displaced and this was considered failure. Flow conditions shown in Photo 24 indicate energy dissipation was improved, but much turbulence occurred downstream from the barges.

Types 20 and 21 scour protection plans

28. A third barge was placed in the model to form the type 20 scour protection plan shown in Plate 20. The walls between the first and second barges were 9 ft high and the walls between the second and third barges were 6 ft high. The downstream wall of the third barge remained 12 ft high and the 3-ft sill remained at the end of the existing structure. Stones 4 to 5 ft in equivalent diameter were placed on a 1V on 3H downward slope below the barges. Results of a test conducted for 5 hr (prototype) with gate 3 opened fully to the normal pool and a tailwater of 797 are shown in Photo 25. The stones were

displaced by the flow plunging over the downstream wall of the last barge as shown in Photo 26. The downstream wall of the third barge was lowered to 6 ft, type 21 scour protection plan shown in Plate 21. Stones 4 to 5 ft in diameter were placed horizontally for a distance of 25 ft downstream from the barges. Flow conditions were improved because the flow no longer plunged over the wall of the last barge, Photo 27, but considerable turbulence and high velocity flow caused the stones downstream from the barges to be displaced.

Type 22 scour protection plan

29. The walls between the first and second barges were lowered to 6 ft and the 3-ft vertical sill at the end of the existing structure was removed because prototype construction was not considered practical. This was the type 22 scour protection plan shown in Plate 22. Flow conditions with this design for gate 3 opened fully to the normal upper pool and minimum tailwater el 797 are shown in Photo 28. The 4- to 5-ft-diameter stones placed downstream from the barges were displaced for these conditions and also when tested with normal upper pool, a 6-ft gate opening, and normal and minimum tailwater. Tests were conducted with gate 3 opened 6 ft because this gate opening was sufficient to pass ice and previous tests had indicated that an acceptable design utilizing barge revetment could not be developed for the flow conditions caused by operations with one gate opened fully to the normal pool and minimum tailwater, due to topography constraints below the dam. Flow conditions with normal upper pool, a 6-ft gate opening, and normal and minimum tailwater are shown in Photo 29. Scour in the exit channel after 5 hr of operation with these conditions is shown in Photo 30.

Type 23 scour protection plan

30. The walls between the first and second barges were raised back to 12 ft with the walls between the second and third barges and the downstream wall of the third barge 6 ft high. This was the type 23 scour protection plan and is shown in Plate 23. Scour in the exit channel after 5 hr of operation with gate 3 open 6 ft, normal upper pool, and a tailwater of 797 is shown in Photo 31a. Energy dissipation over the barge revetment was considered satisfactory and the flow conditions during the test are shown in Photo 32a. Since this plan remained stable for the minimum tailwater, a test was conducted to check flow conditions with a 6 ft gate opening, normal upper pool, and a normal tailwater elevation of 803.6. These flow conditions are shown in Photo 32b and scour in the exit channel after 5 hr of operation with

these conditions is shown in Photo 31b. The plan was less effective with the higher, normal tailwater because the flow rode over the barges and plunged through the tailwater at the end of the third barge causing severe scour and displacement of the stone protection.

Type 24 scour protection plan

31. The walls between the first and second barges were lowered to 9 ft with the remaining walls 6 ft high to form the type 24 scour protection plan shown in Plate 24. A test was conducted for 5 hr with gate 3 opened 6 ft, normal upper pool and minimum tailwater and scour in the exit channel after completion of the test is shown in Photo 33a. The stones failed due to displacement by the flow conditions shown in Photo 34a. Results from another test conducted with the normal tailwater of 803.6 are shown in Photo 33b and indicate the stones failed again. Flow conditions during the test are shown in Photo 34b.

Type 25 scour protection plan

32. The 3-ft-high sill at the end of the existing structure improved energy dissipation in the barges, but it was not considered a feasible modification. The walls between all the barges and the downstream wall of the last barge were lowered to 6 ft. This modification is shown in Plate 25 and was noted as the type 25 scour protection plan. Tests were conducted with gate 3 opened 6 ft, normal upper pool, and tailwaters of 797 and 803.6. Results from the test with a tailwater of 797 are shown in Photo 35a and indicate failure of the stones. Flow conditions during the test are shown in Photo 36a. Scour in the exit channel after 5 hr of operation with a normal tailwater of 803.6 is shown in Photo 35b and indicate stone protection failed during this test. Flow conditions during the test are shown in Photo 36b.

Type 26 scour protection plan

33. In the type 26 scour protection plan, Plate 26, the walls between the first and second barges were raised to 9 ft high and the walls between the second and third barges were 6 ft high as well as the wall at the downstream end of the third barge. A horizontal blanket of 4- to 5-ft-diameter stones was placed for a distance of 25 ft below the third barge. This plan was tested with normal upper pool, gate 3 opened 6 ft and a tailwater of 797. The stones below the barges failed shortly after the test was begun and the scour after 5 hr of operation is shown in Photo 37a. Flow conditions during the test are shown in Photo 38a. Flow conditions with normal tailwater for a 6-ft

gate opening are shown in Photo 38b and the scour after 5 hr of operation with these flow conditions is shown in Photo 37b.

Type 27 scour protection plan

34. The wall between the first and second barges are raised to 12 ft to form the type 27 scour protection plan, shown in Plate 27. This plan was tested with gate 3 opened 6 ft, normal upper pool, and tailwaters of 797 and 803.6. The results from these tests, shown in Photo 39, indicate failure of the 4- to 5-ft-diameter stones for the normal tailwater and the stones were stable for the minimum tailwater condition. Flow conditions during these tests are shown in Photo 40. Flow conditions appear worse with the lower tailwater, Photo 40a, but actually the energy dissipation is better with this flow condition.

Grout-filled fabric bags

35. During the model study, tests were conducted with grout-filled fabric bags, 20 ft long by 6.75 ft wide by 2.75 ft thick, since previous studies had shown them to be an alternative to riprap. The bags were placed in various configurations downstream from the structure. The bags were unstable in the supercritical flow that exited the stilling basin with the normal upper pool, a 6-ft gate opening, and a minimum tailwater elevation of 797.

PART IV: SUMMARY AND RECOMMENDATIONS

36. Model tests revealed that scour protection more substantial than riprap was required to protect the area below the existing stilling basin. The only scour protection plan that remained stable for the flow conditions with one gate fully opened to the normal upper pool and minimum tailwater was the type 12 scour protection plan shown in Plate 12. This plan consisted of a secondary stilling basin that provided good energy dissipation of the super-critical flow exiting the existing basin and a reasonable size riprap provided the protection required downstream from the secondary basin. The reason the secondary basin functioned satisfactorily for the minimum tailwater conditions was because the floor of the basin was set at an elevation that provided enough depth for a hydraulic jump to occur with the aid of the baffle blocks and an end sill.

37. Numerous scour protection plans constructed of barges and grouted riprap were tested to determine if this type structure would serve as a secondary stilling basin. This approach was attempted since the scour protection had to be constructed under water. None of these plans were hydraulically effective with one gate fully open to the normal upper pool and minimum tailwater because the top of the barge(s) could not be placed low enough to provide a good hydraulic jump. Barges filled with grouted riprap will serve to protect the area immediately downstream of the stilling basin, however, the flow conditions associated with them are not desirable. If barge revetment is utilized, there should be at least two 26-ft wide barges placed downstream of the stilling basin and three is preferable. Scour to some degree should be expected, but the barge revetment will prevent severe scour immediately adjacent to the structure. The downstream wall of the downstream barge should be cut down to 6 ft (level with the grouted riprap) if the top of the grouted riprap cannot be placed lower than el 789. This will prevent constriction of the flow and a localized increase in velocity. If three barges are utilized and the top of the grouted riprap cannot be placed lower than el 789, the walls between the second and third barges should be cut down to 6 to 7 ft and the walls between the first and second should be cut down to 7 to 9 ft to help break up the high velocity jet. However, it should not project more than 3 ft above the grouted riprap because excessive forces may

be exerted on it. These types of barge configurations were tested in the type 22 scour protection plan, Plate 22, and the type 24 scour protection plan, Plate 24. Large stones and grout-filled fabric bags did not remain stable when placed downstream from the barges so they are not recommended if barges are utilized.

38. The type 22 scour protection plan, while less than desirable hydraulically than type 12, should be adequate for ice and debris passage with gate openings equal to or less than 6 ft. Scour downstream from the barges can be expected during these operations, but this plan should prevent undermining of the existing stilling basin. Model results indicate that flow conditions for normal operating conditions are certainly capable of scouring a streambed.

39. The existing scour downstream from the stilling basin is less than one would expect after observing model flow conditions. This is probably due to the composition of the streambed, however, even competent streambeds have been observed to scour after extended periods of adverse flow conditions.

40. An alternative method for repairing the scoured area immediately adjacent to and possibly underneath the stilling basin is a wedge of concrete. The wedge would prevent additional undermining of the stilling basin and protect the structural integrity. This alternative was not model tested because its performance could not be documented with the type model used for this study. The performance of a concrete wedge would depend on the ability to reinforce the wedge within itself and to the existing downstream face of the stilling basin and streambed, and the extent of scour that occurs at the toe of the wedge. Any alternative chosen to repair the area downstream from the stilling basin should be monitored to determine if additional scour is occurring.

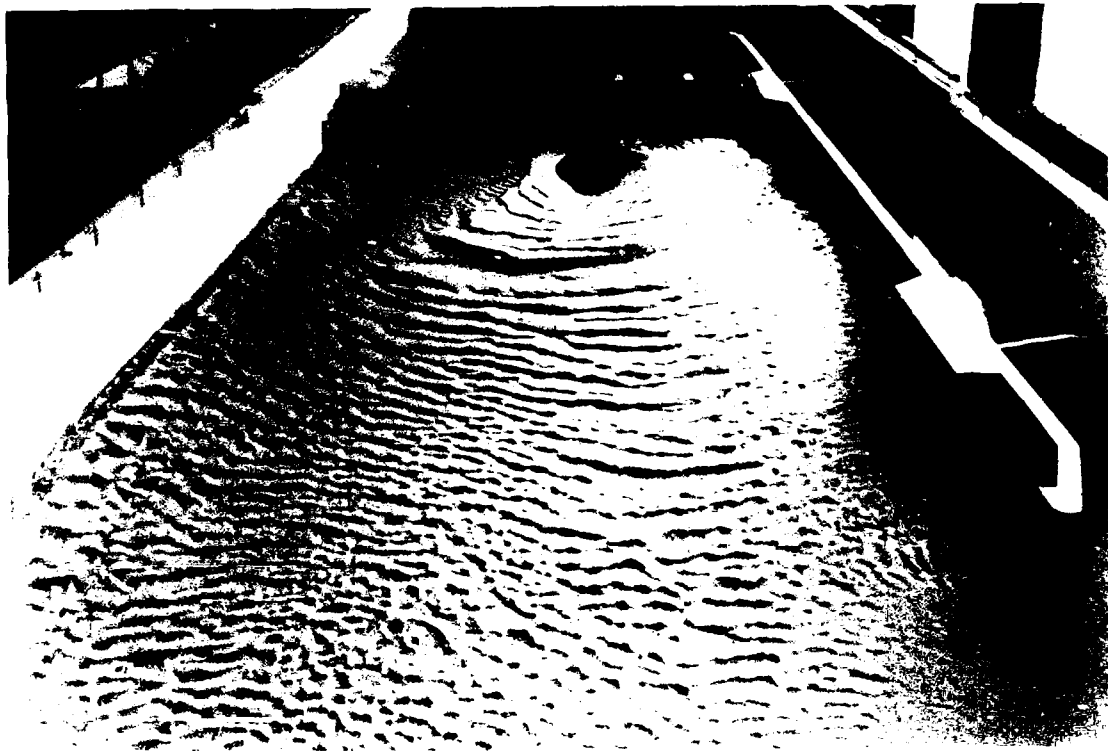

a. Looking upstream

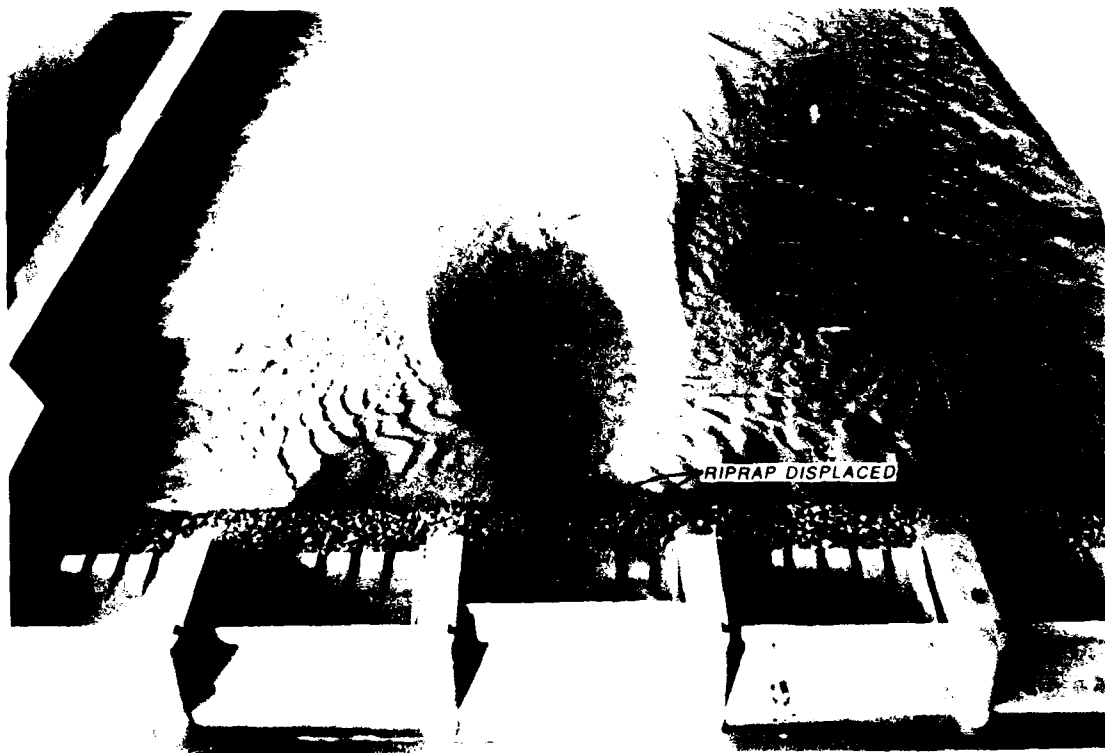

b. Looking downstream

Photo 1. Type 1 riprap protection plan, scour after 5 hr of operation:
normal pool el 814, normal tailwater el 803.6, gate opening 6 ft

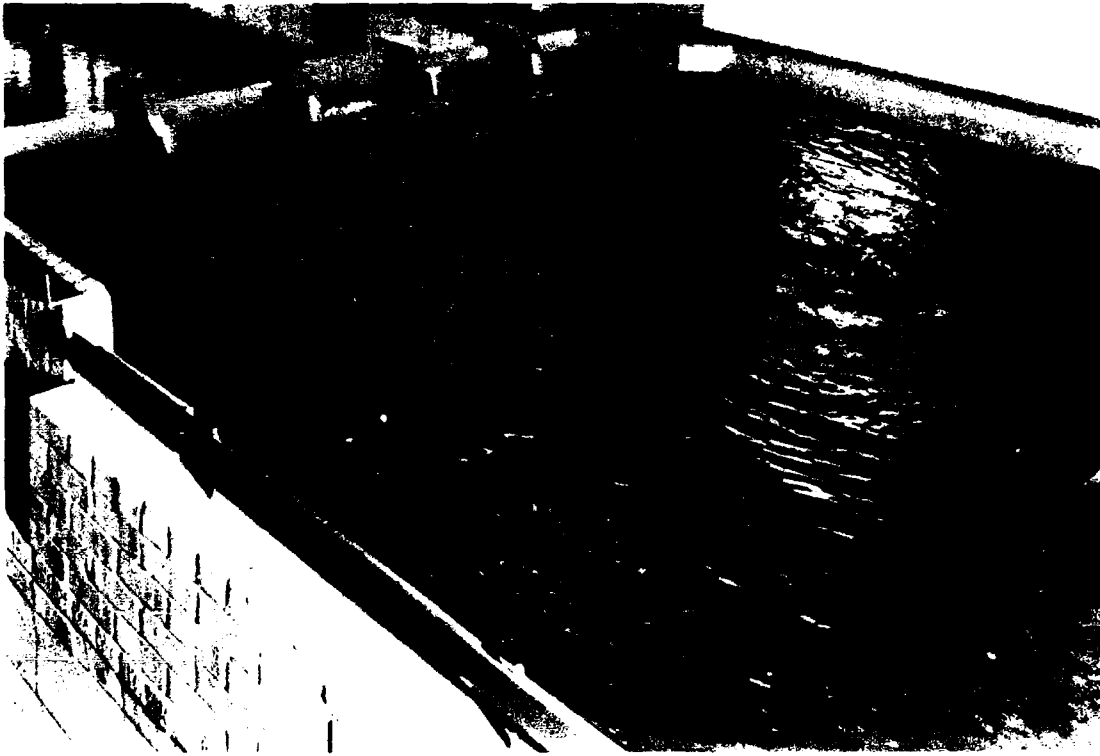
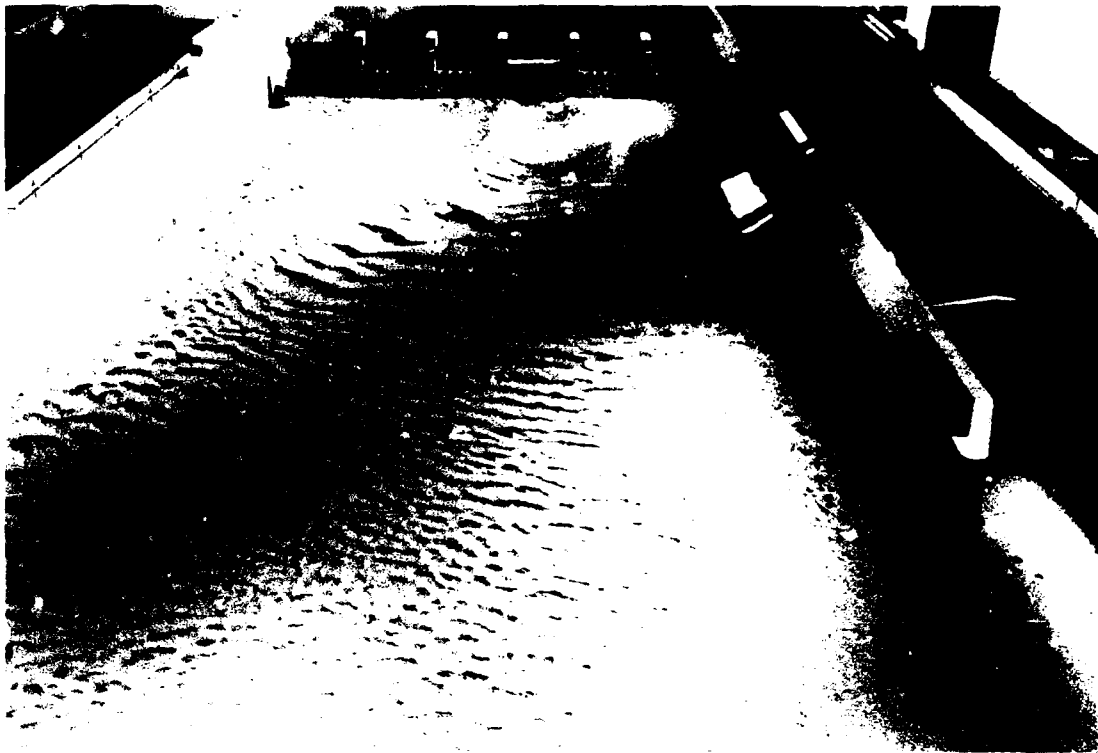

Photo 2. Flow conditions, type 1 riprap plan, normal pool el 814,
normal tailwater el 803.6, gate opening 6 ft



Photo 3. Flow conditions, type 1 riprap plan, normal pool el 814,
normal tailwater el 805.4, gate opening 8 ft



a. Looking upstream



b. Looking downstream

Photo 4. Type 2 riprap protection plan, scour after 5 hr of operation;
pool el 814, tailwater el 803.6, gate opening 6 ft

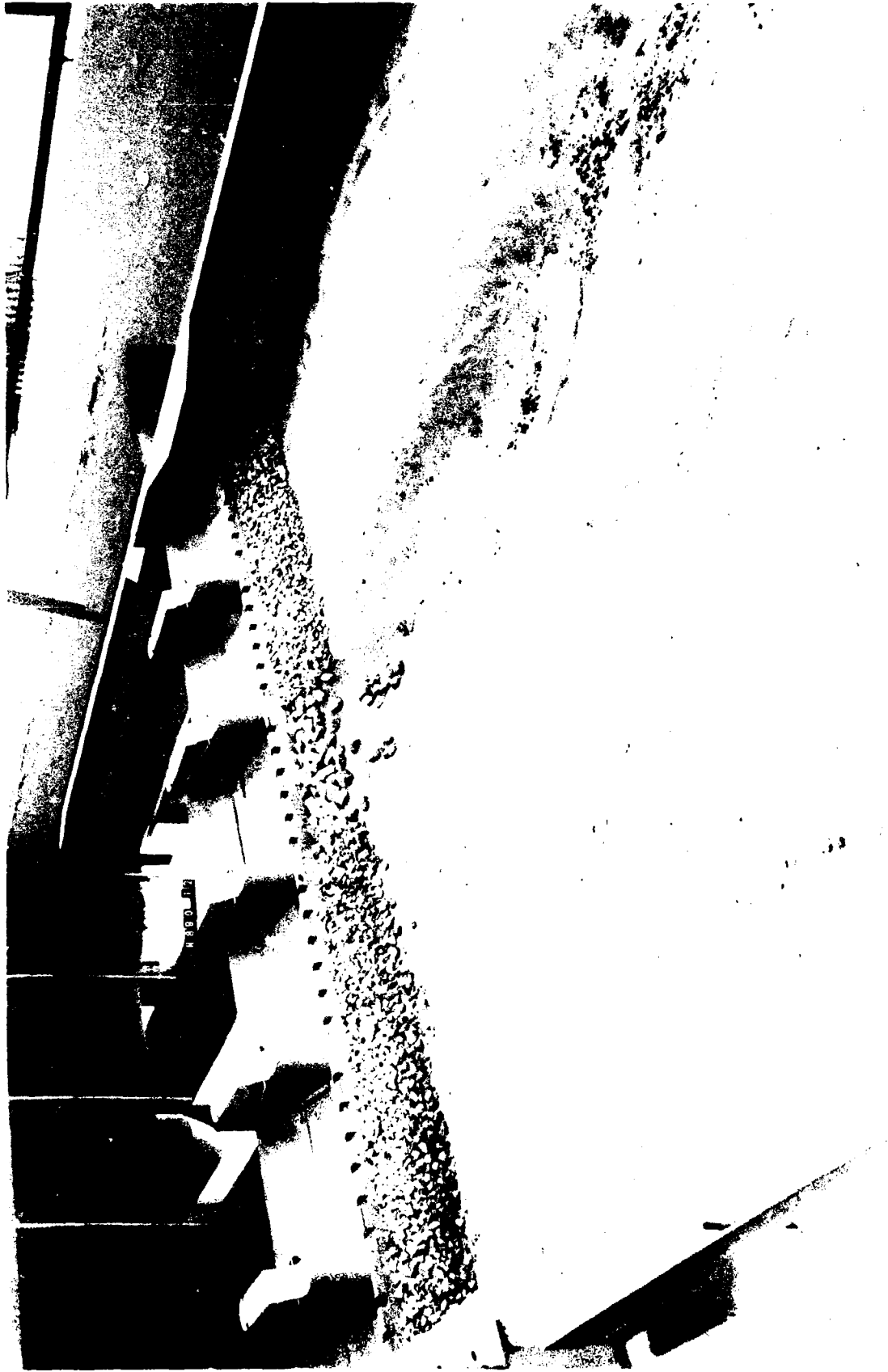

Photo 5. Failure of type 2 riprap protection plan



Photo 6. Failure of riprap downstream at barge
(Type 3 scour protection plan)

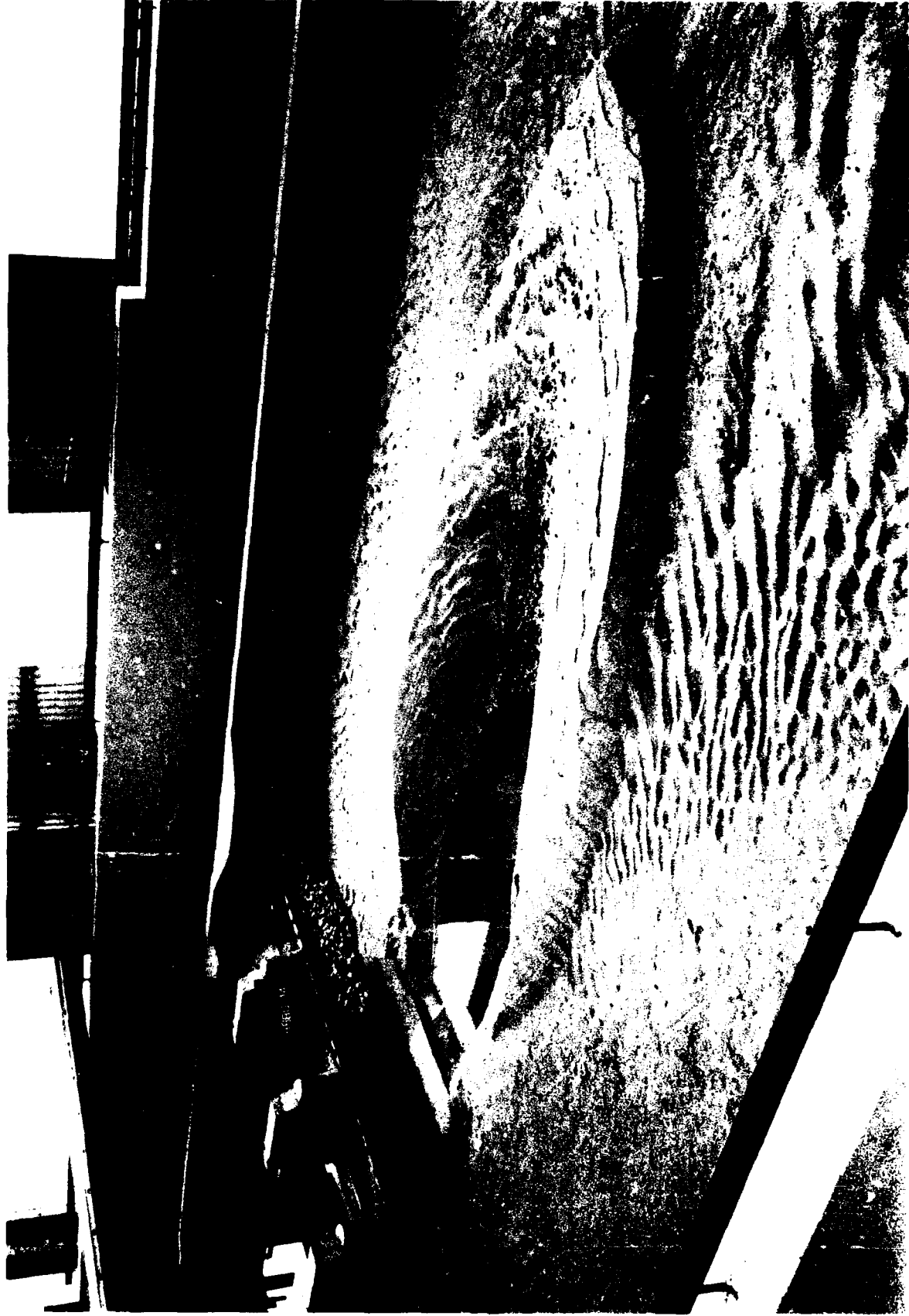
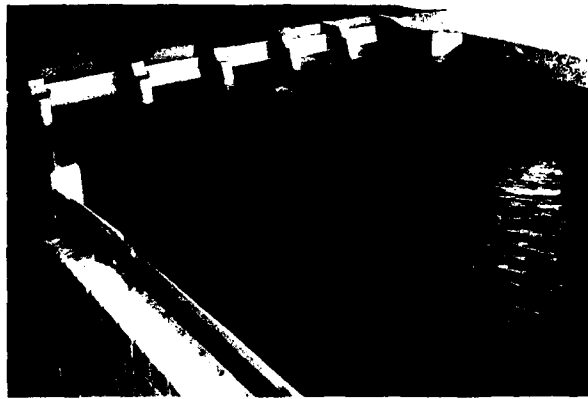
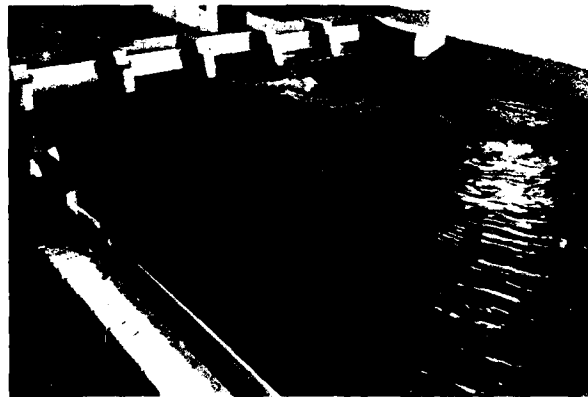

Photo 7. Scour below type 7 scour protection plan



a. 3-ft gate opening



b. 6-ft gate opening



c. Full gate opening

Photo 8. Flow conditions with no scour protection downstream of structure; normal pool el 814, minimum tailwater el 797



a. 3-ft gate opening
tailwater el 798.4

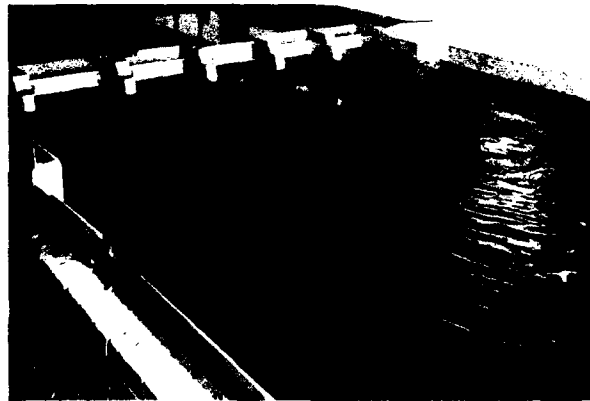

b. 6-ft gate opening
tailwater el 803.6



c. Full gate opening
tailwater el 807.9

Photo 9. Flow conditions with no scour
protection downstream of structure;
normal pool el 814, normal
tailwater el



Photo 10. Scour downstream of type 8 scour protection plan after 5 hr of operation with normal upper pool, gate 3 open full and minimum tailwater



Photo 11. Riprap failure downstream of type 9 scour protection plan after 5 hr of operation with normal upper pool, gate 3 open full and minimum tailwater



Photo 12. Type 10 scour protection plan after 5 hr of operation with normal upper pool, gate 3 open full and minimum tailwater

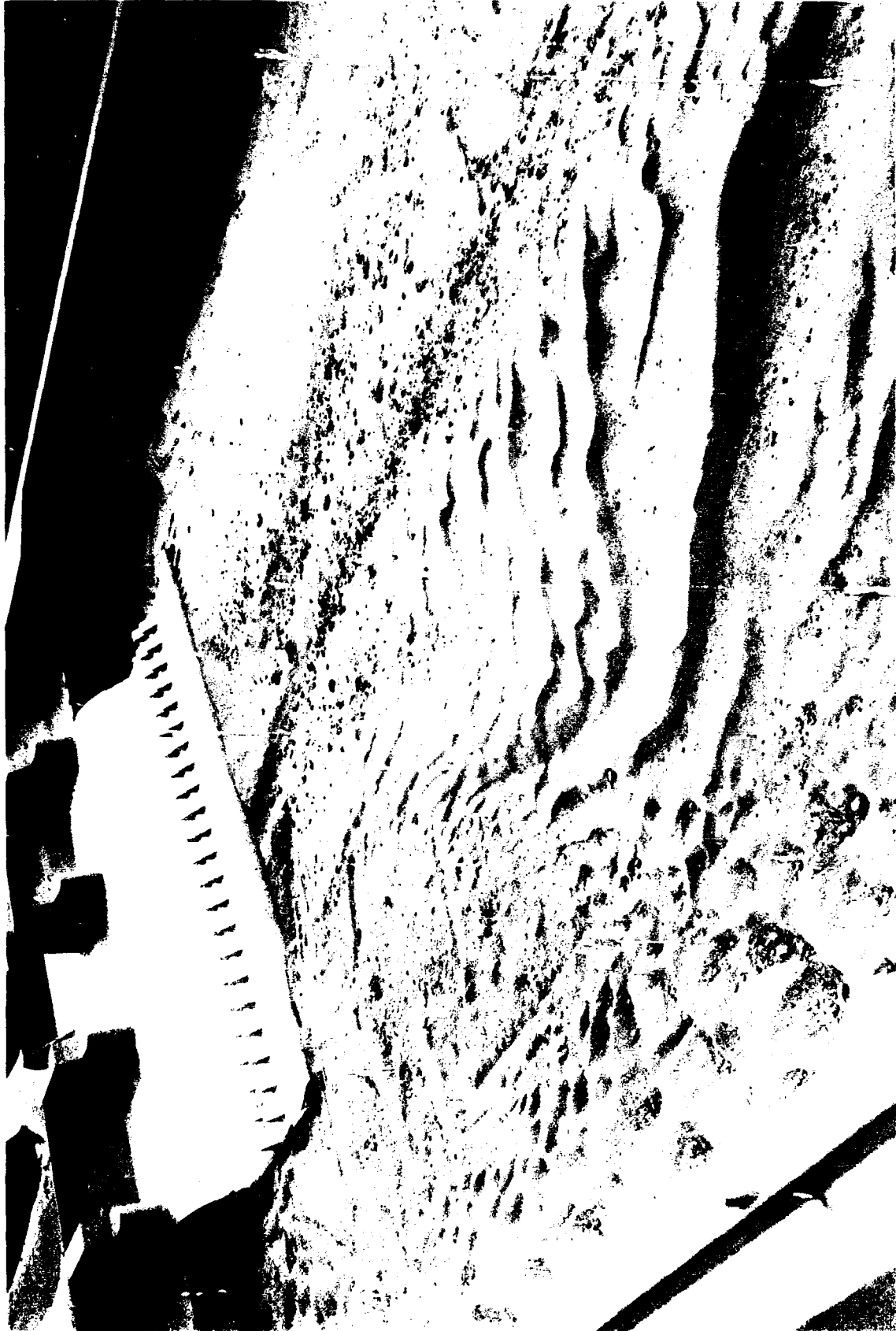

Photo 13. Scour downstream of type 11 scour protection plan after 5 hr of operation with normal upper pool, gate 3 open full and minimum tailwater



Photo 14. Type 12 scour protection plan after 5 hr of operation with normal upper pool, gate 3 open full and minimum tailwater



Photo 15. Flow conditions with type 12 scour protection plan, normal upper pool el 814, minimum tailwater el 797, gate 3 open full



Photo 16. Scour downstream of type 12 scour protection plan after 5 hr of operation with upper pool el 823.6, tailwater el 797.0, gate 3 open full



Photo 17. Flow conditions with type 12 scour protection plan,
upper pool el 823.6, tailwater el 797, gate 3 open full



Photo 18. Flow conditions with type 12 scour protection plan, normal upper pool el 814, minimum tailwater el 797, gate 3 open 6 ft



Photo 19. Flow conditions with type 14 scour protection plan, normal upper pool el 814, minimum tailwater el 797, gate 3 open full

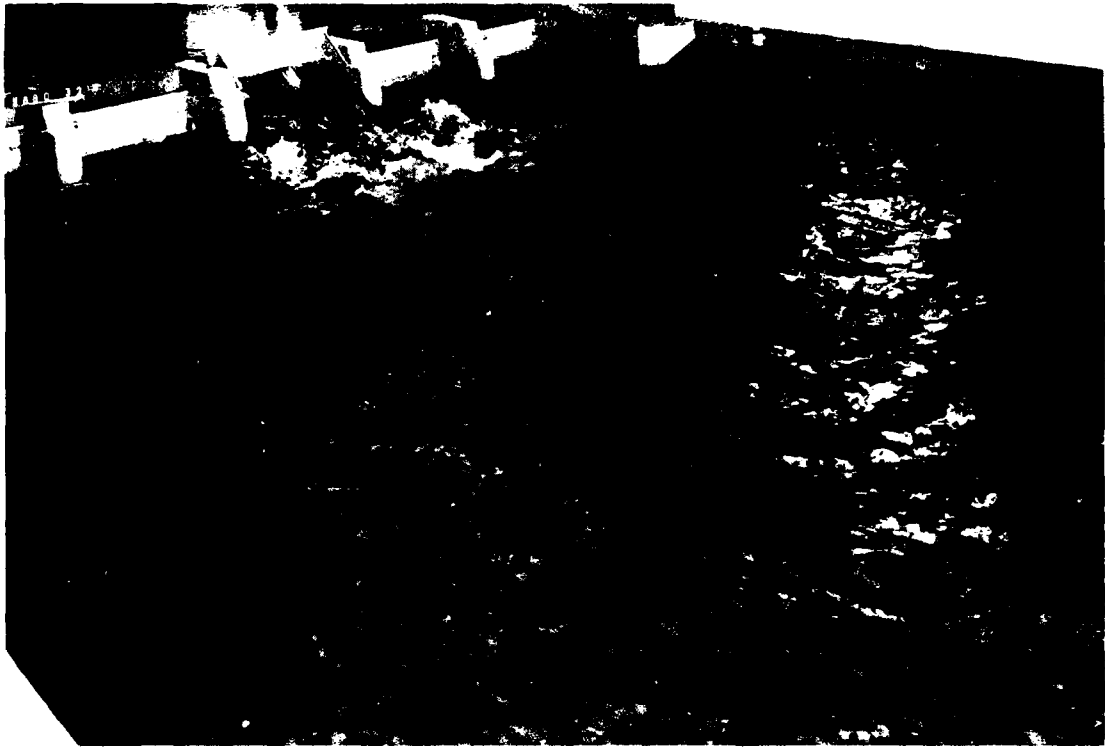

a. Tailwater el 797

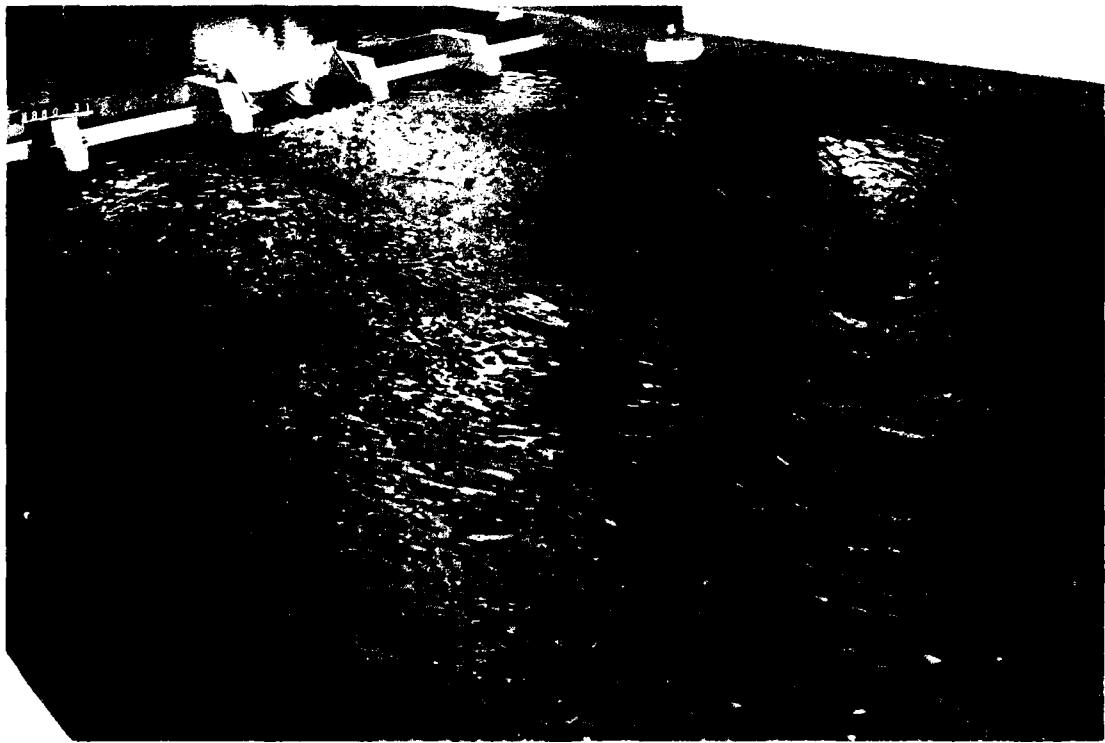

b. Tailwater el 807.9

Photo 20. Flow conditions, type 15 scour protection plan,
normal pool el, gate 3 open full



Photo 21. Type 16 scour protection plan



Photo 22. Flow conditions with type 16 scour protection plan, normal upper pool el 814, minimum tailwater el 797, gate 3 open full



Photo 23. Scour downstream from type 19 scour protection plan after 5 hr of operation with normal upper pool, minimum tailwater, gate 3 open full

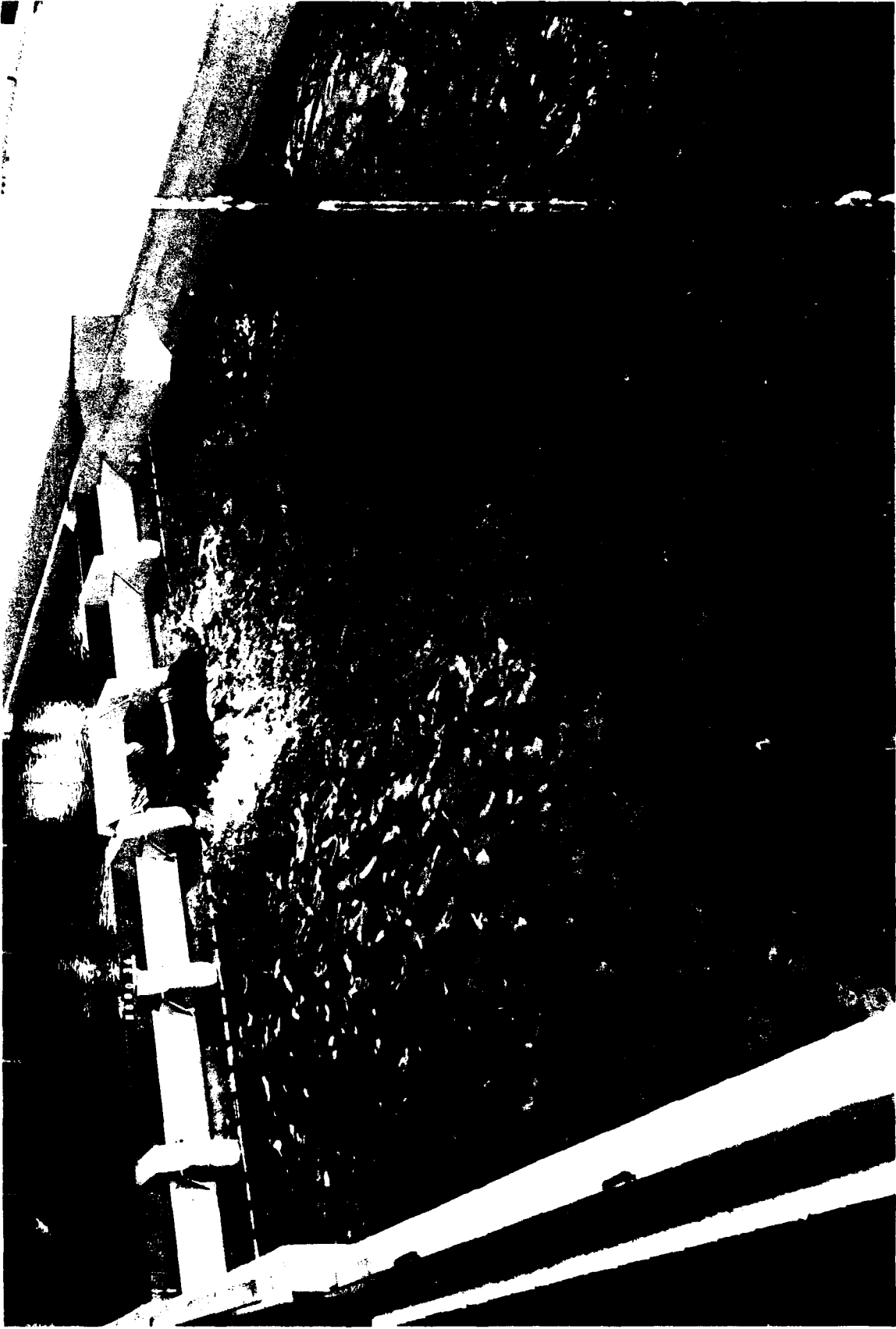

Photo 24. Flow conditions with type 19 scour protection plan, normal upper pool el 814, minimum tailwater el 797, gate 3 open full

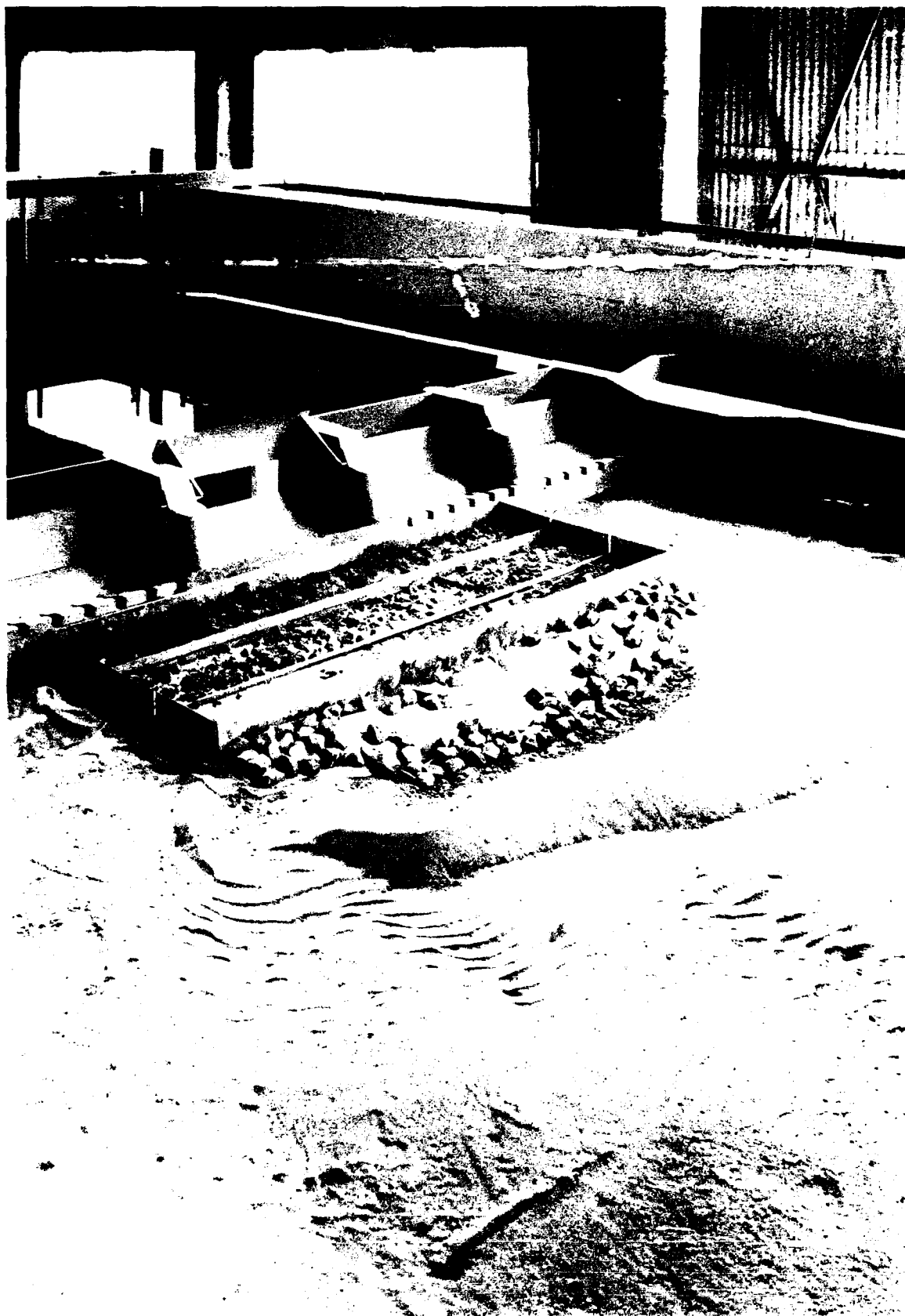

Photo 25. Scour downstream of type 20 scour protection plan after 5 hr of operation; normal upper pool, minimum tailwater, gate 3 open full

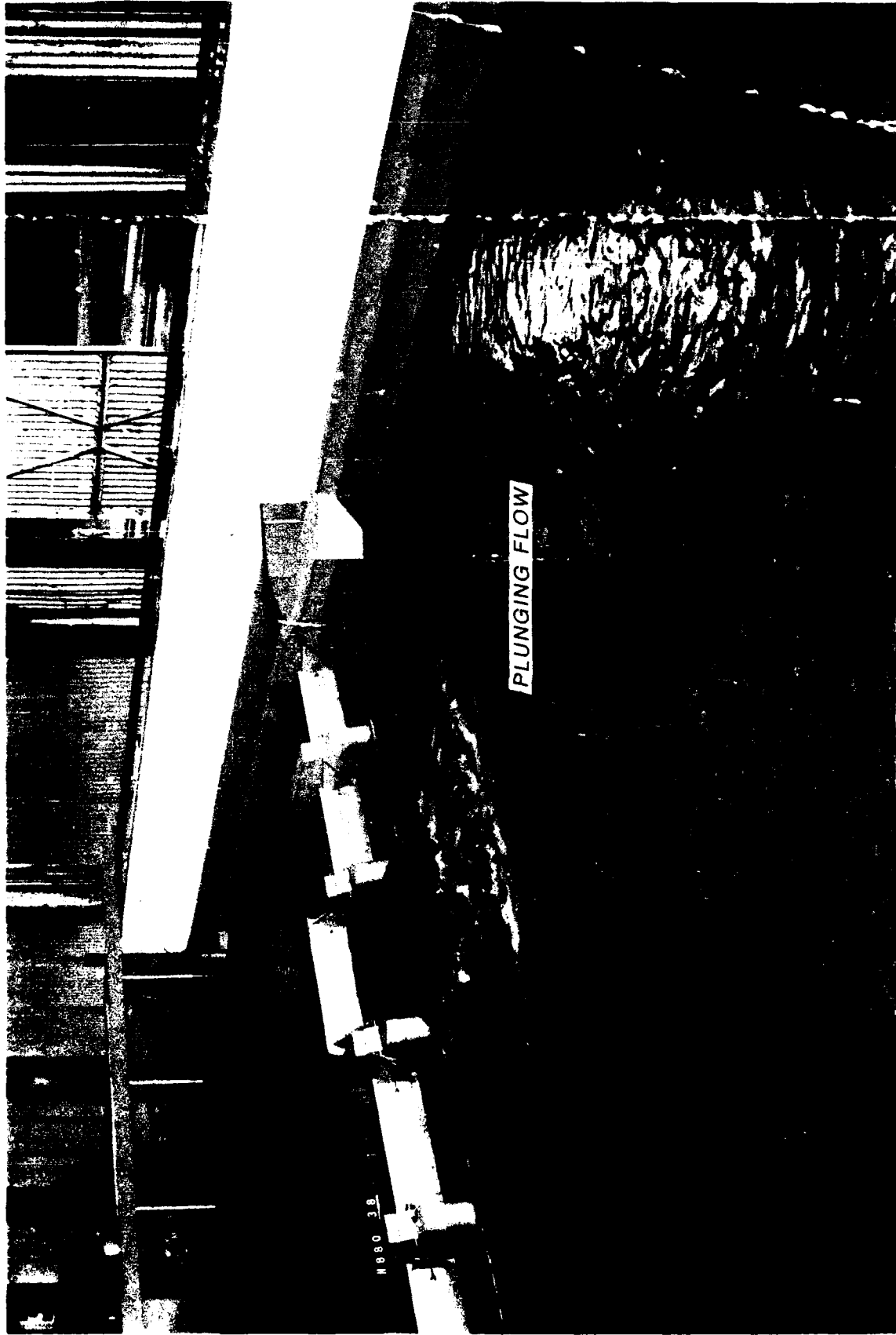

Photo 26. Flow conditions with type 20 scour protection plan, normal upper pool el 814, minimum tailwater el 797, gate 3 open full



Photo 27. Flow conditions with type 21 scour protection plan, normal upper pool el 819, minimum tailwater el 797, gate 3 open full



Photo 28. Flow conditions with type 22 scour protection plan, normal upper pool el 814.0, minimum tailwater el 797, gate 3 open full



a. Tailwater el 803.6

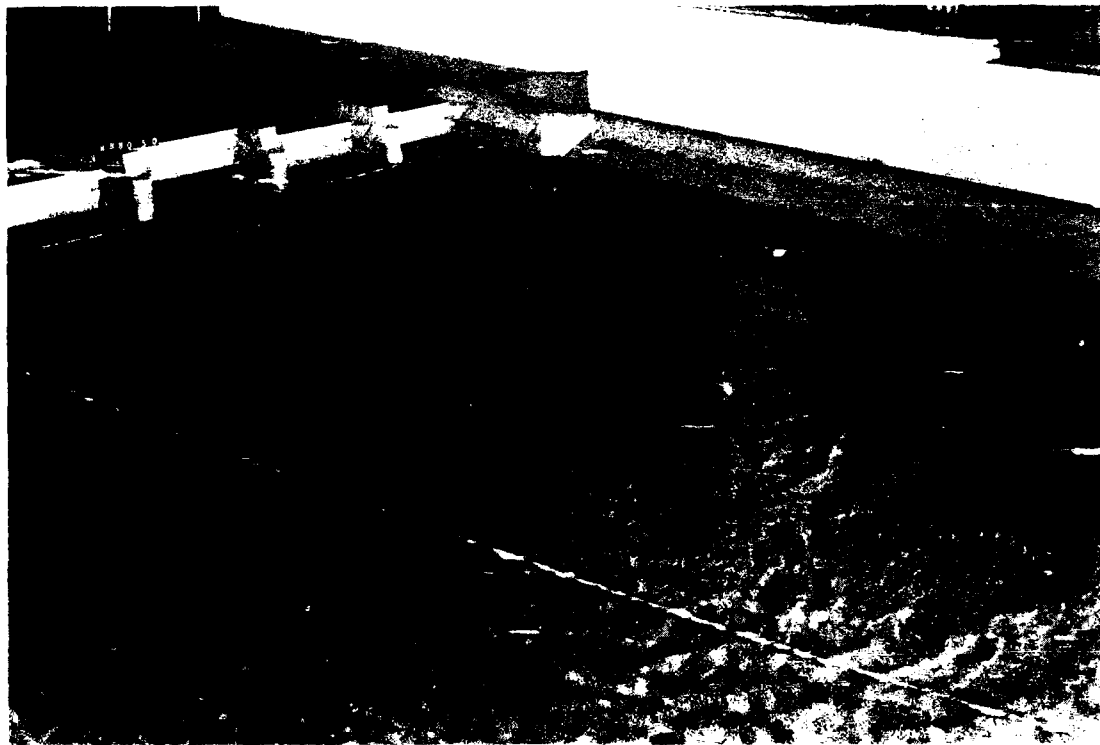

b. Tailwater el 797

Photo 29. Flow conditions with type 22 scour protection plan, normal upper pool, gate 3 open 6 ft



a. Tailwater el 803.6



b. Tailwater el 797

Photo 30. Scour downstream of type 22 scour protection plan after 5 hr of operation; normal upper pool, gate 3 open 6 ft



a. Minimum tailwater el 797

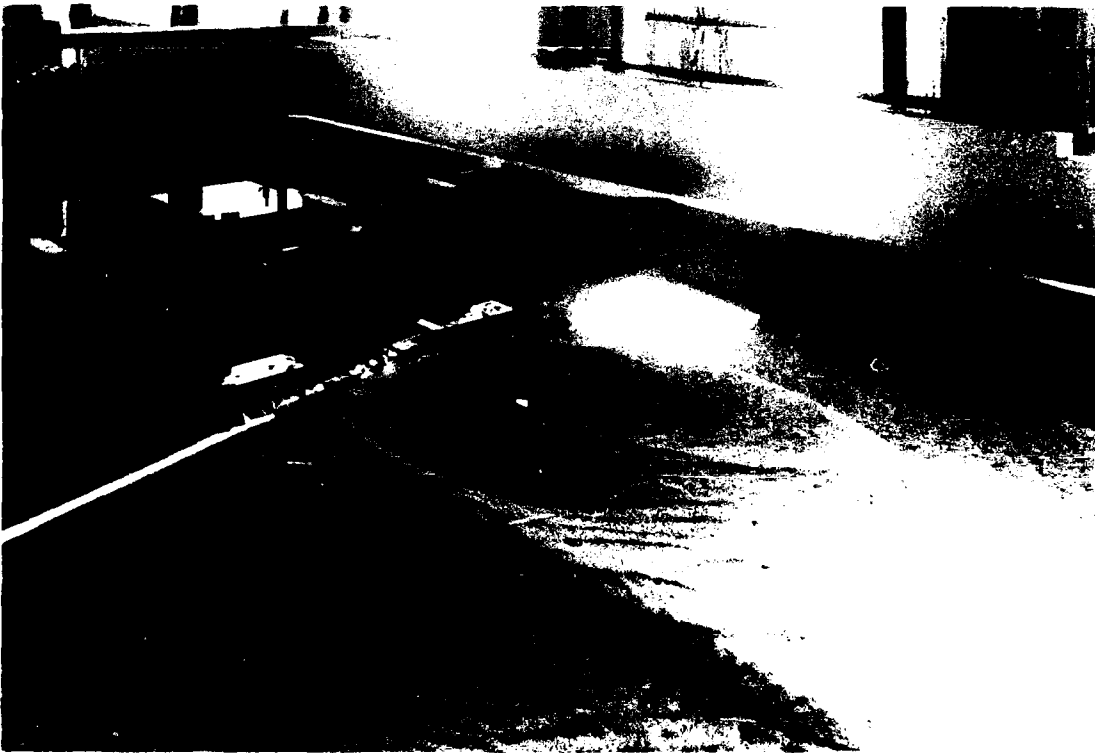

b. Normal tailwater el 803.6

Photo 31. Scour downstream of type 23 scour protection plan after 5 hr of operation; normal upper pool el 814, gate 3 open 6 ft



a. Minimum tailwater el 797

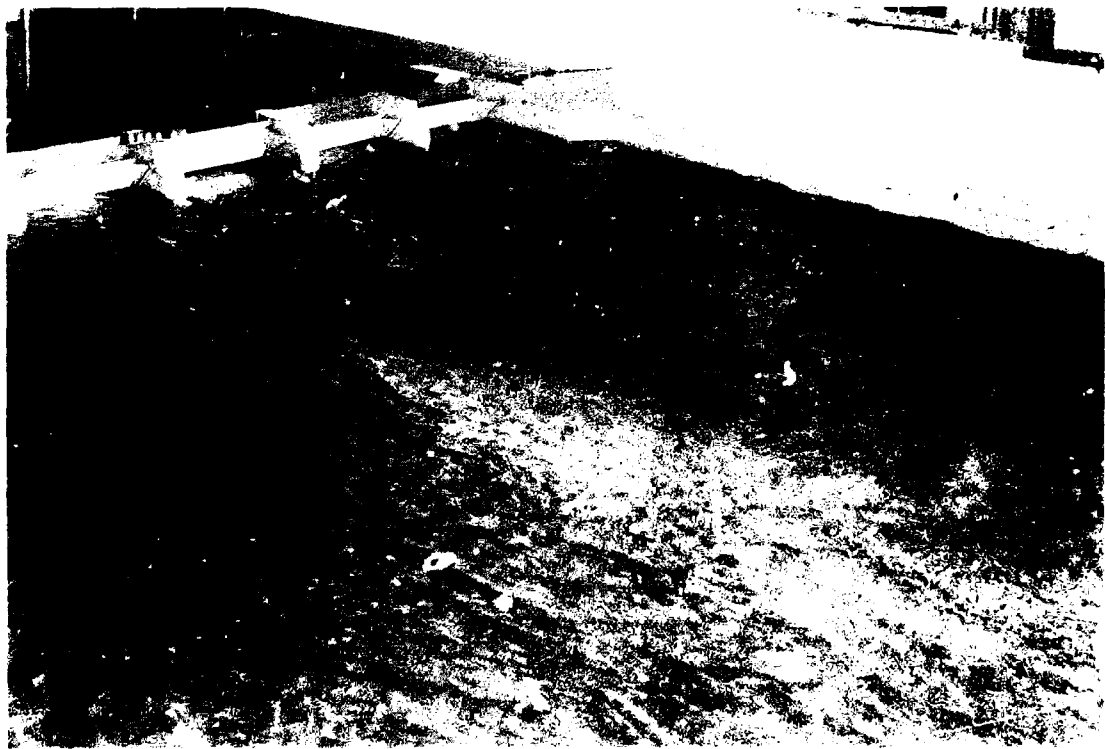

b. Normal tailwater el 803.6

Photo 32. Flow conditions with type 23 scour protection plan, normal upper pool el 814, gate 3 open 6 ft

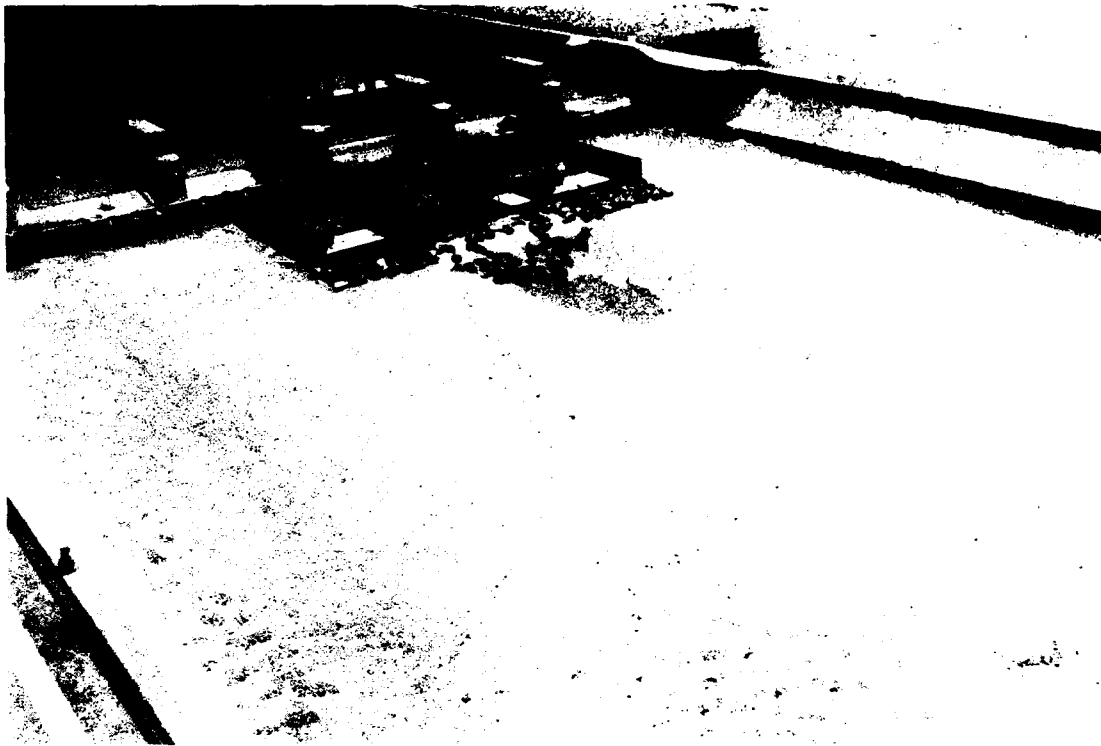

a. Minimum tailwater el 797



b. Normal tailwater el 803.6

Photo 33. Scour downstream of type 24 scour protection plan after 5 hr of operation; normal upper pool el 814, gate 3 open 6 ft

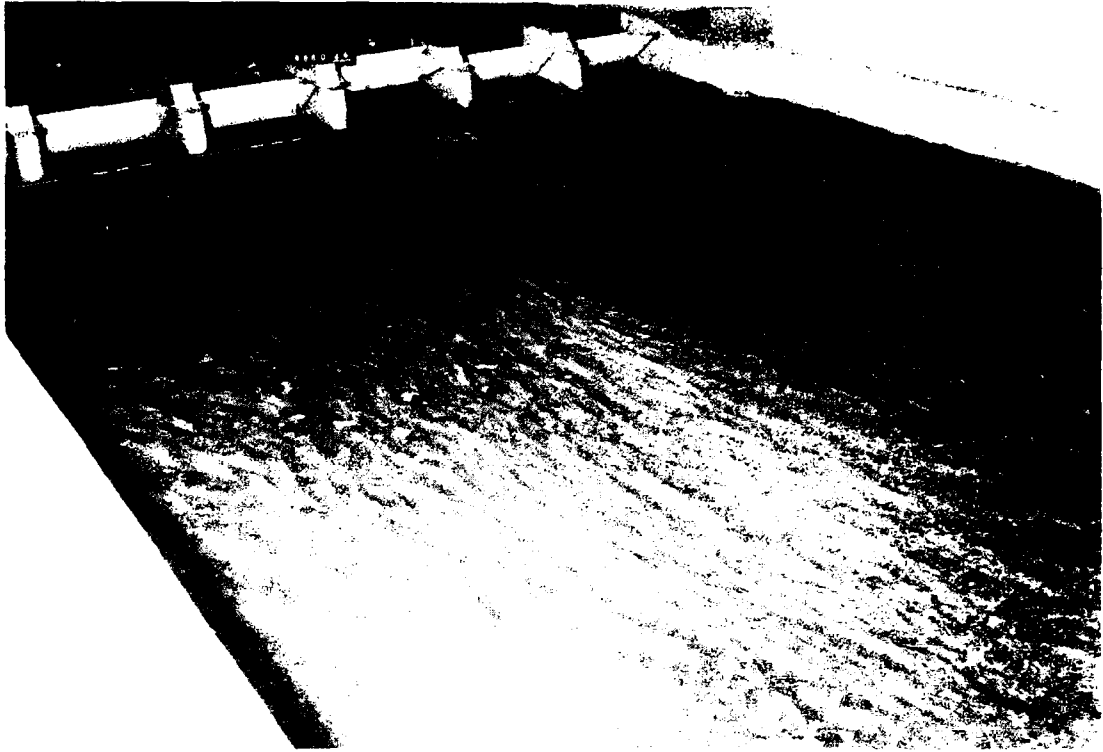

a. Minimum tailwater el 797

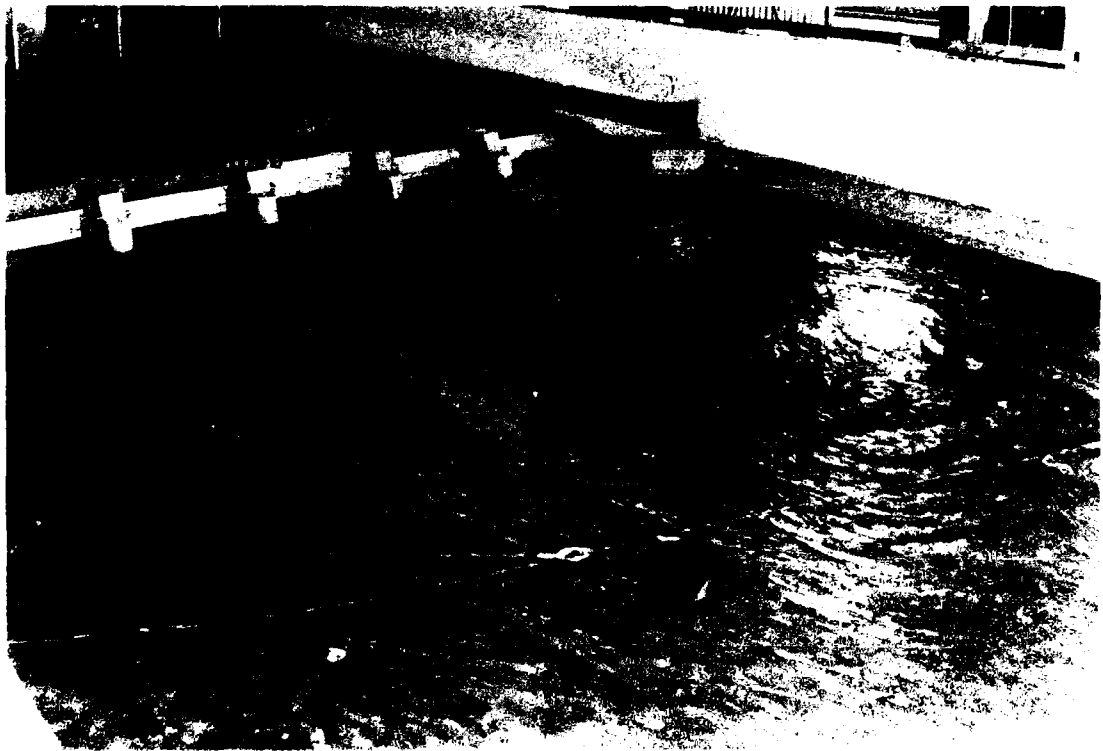

b. Normal tailwater el 803.6

Photo 34. Flow conditions with type 24 scour protection plan, normal pool el 814, gate 3 open 6 ft

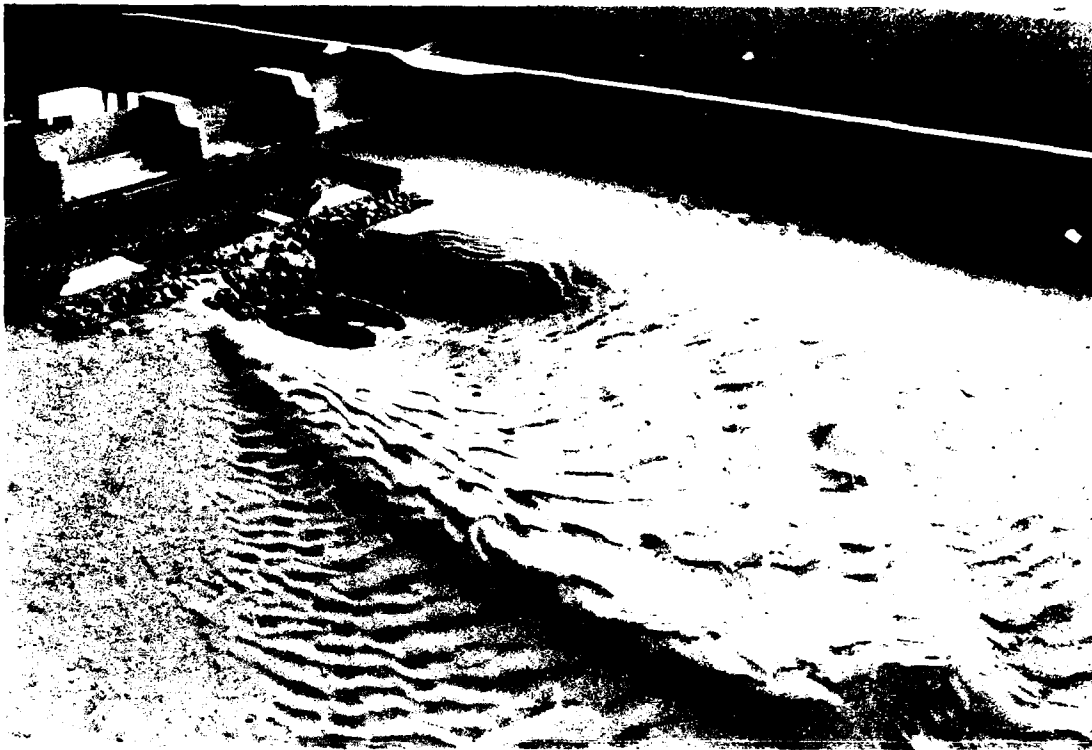

a. Minimum tailwater el 797



b. Normal tailwater el 803.6

Photo 35. Scour downstream of type 25 scour protection plan after 5 hr of operation; normal upper pool el 814, gate 3 open 6 ft

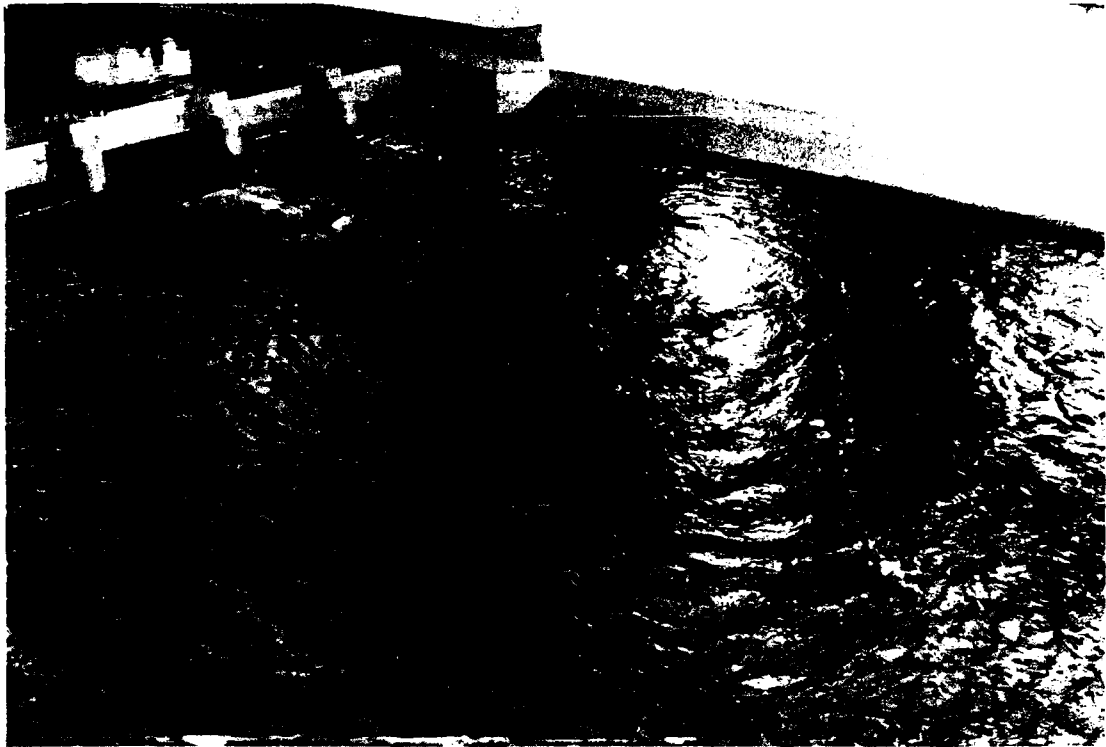

a. Minimum tailwater el 797

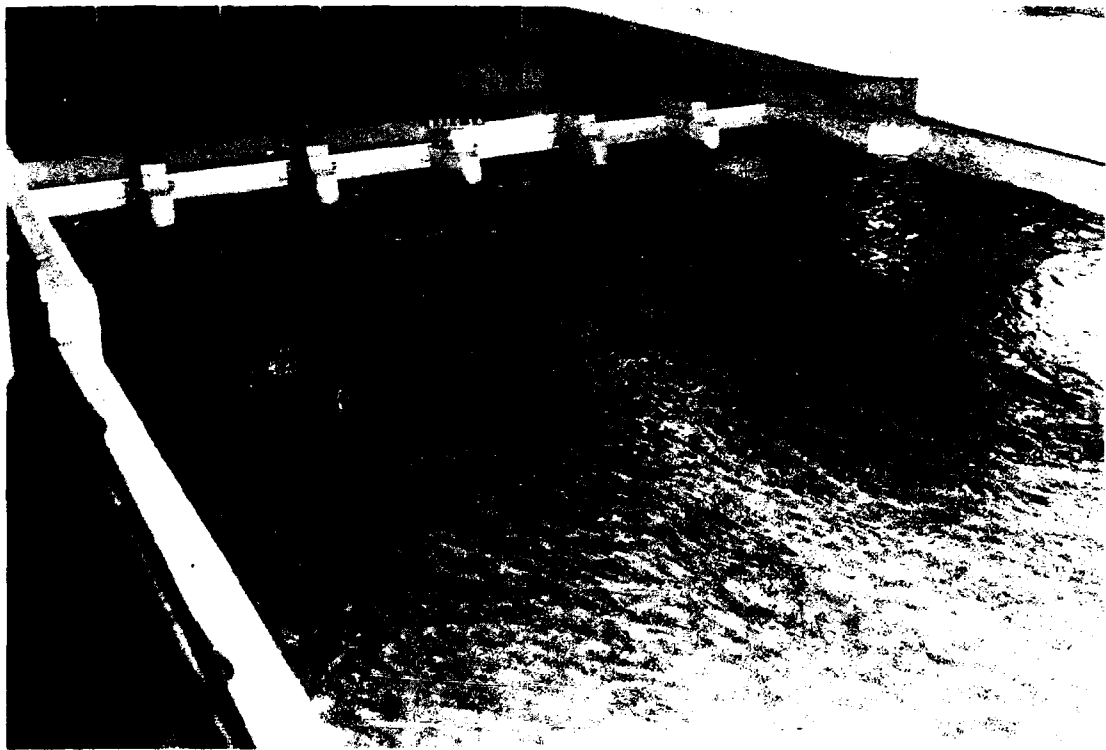

b. Normal tailwater el 803.6

Photo 36. Flow conditions with type 25 scour protection plan, normal upper pool el 814, gate 3 open 6 ft

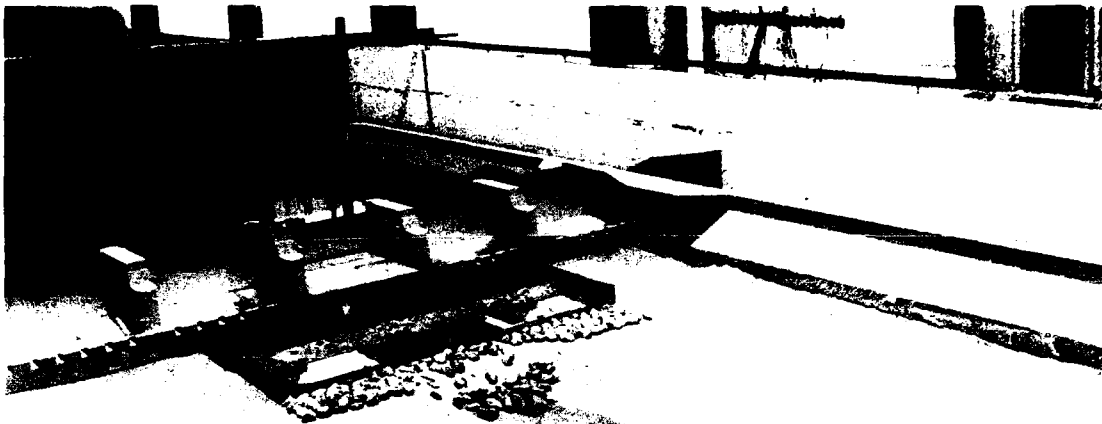

a. Minimum tailwater el 797



b. Normal tailwater el 803.6

Photo 37. Scour downstream of type 26 scour protection plan after 5 hr of operation; normal upper pool el 814, gate 3 open 6 ft



a. Minimum tailwater el 797

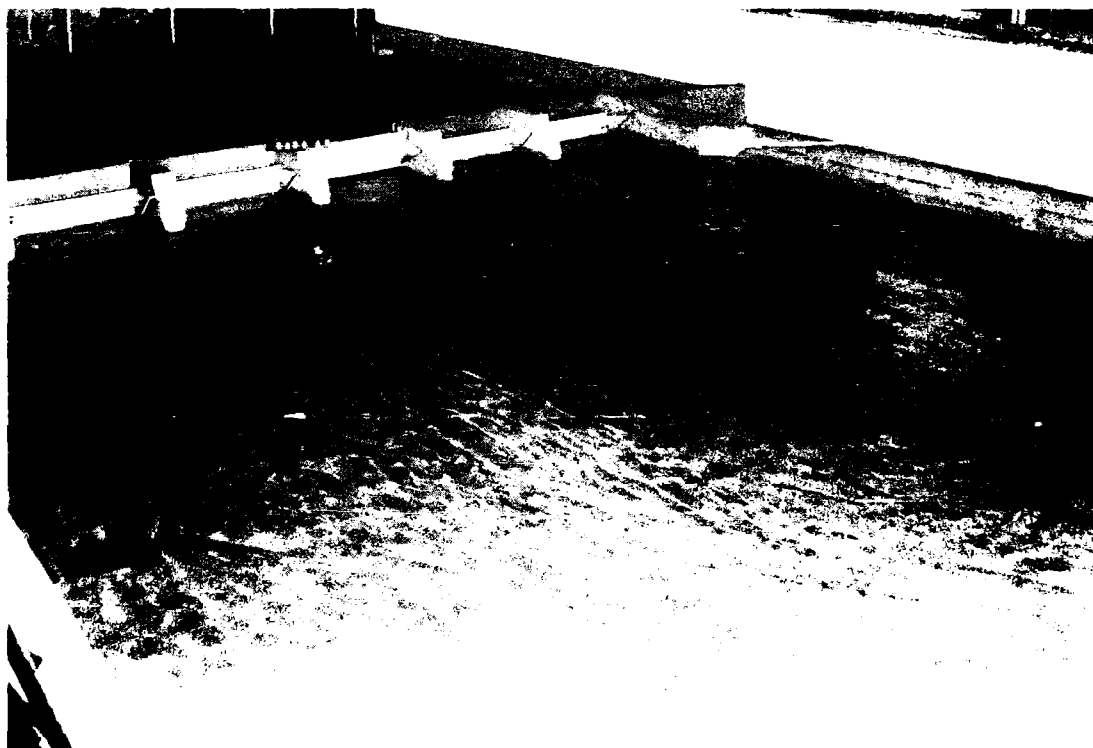

b. Normal tailwater el 803.6

Photo 38. Flow conditions with type 26 scour protection plan, normal upper pool el 814, gate 3 open 6 ft



a. Minimum tailwater el 797

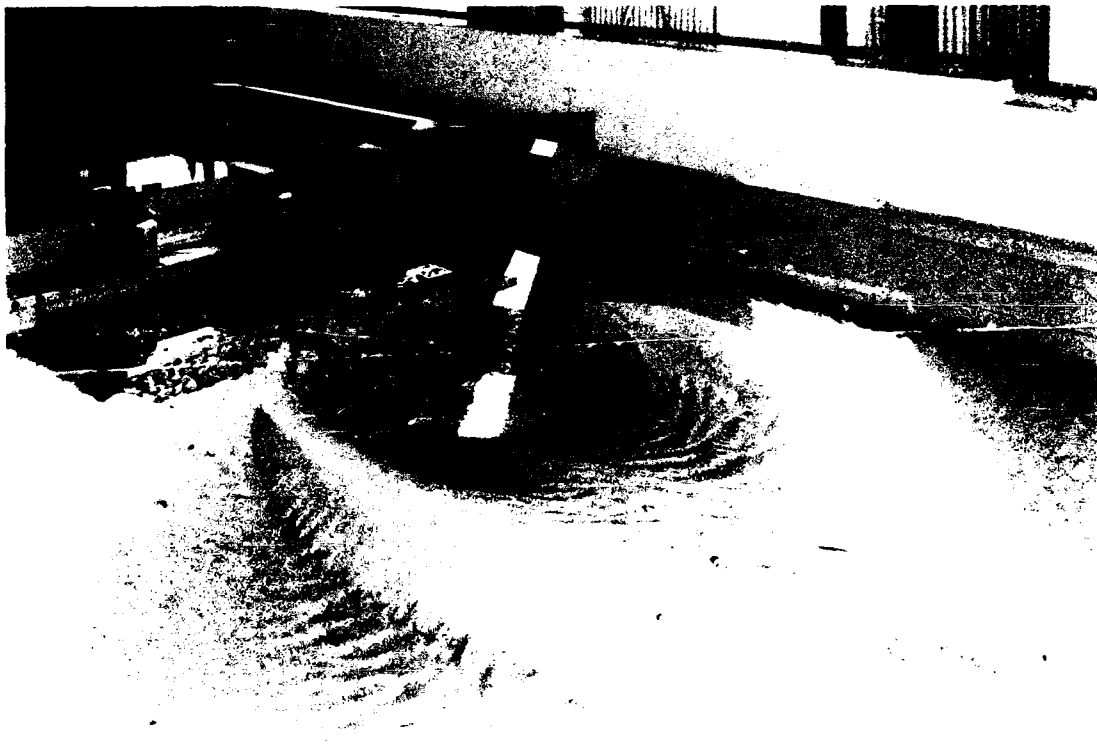

b. Normal tailwater el 803.6

Photo 39. Scour downstream of type 27 scour protection plan after 5 hr of operation; normal upper pool el 814, gate 3 open 6 ft

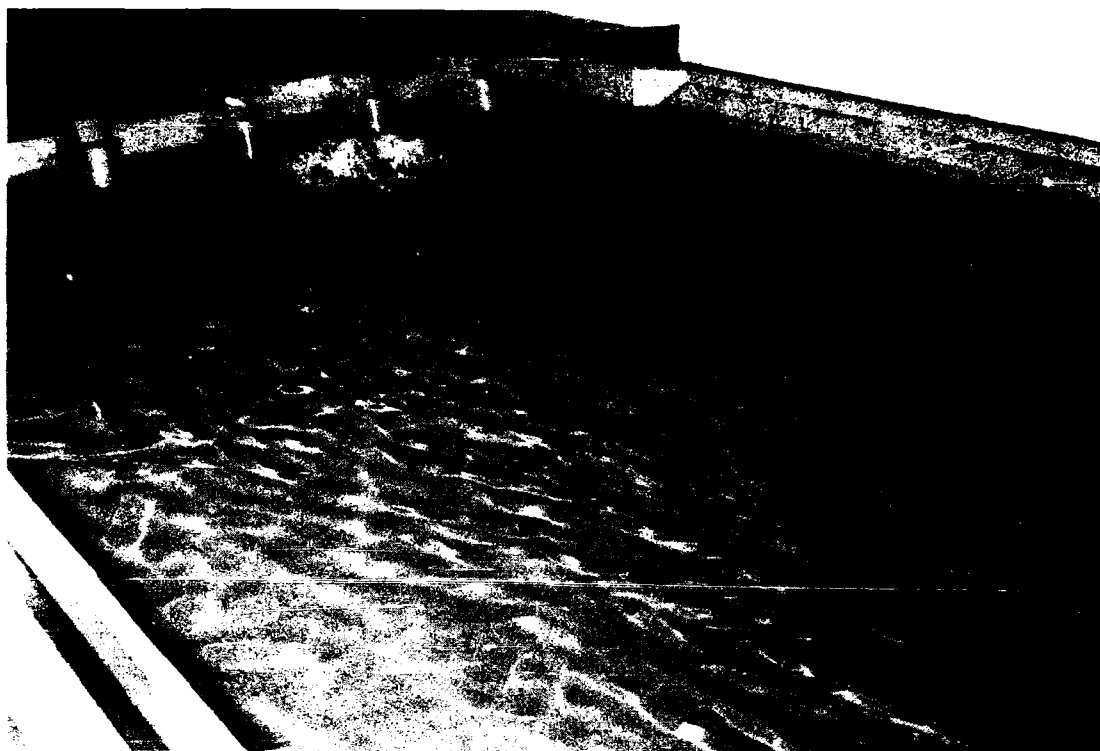

a. Minimum tailwater el 797



b. Normal tailwater el 803.6

Photo 40. Flow conditions with type 27 scour protection plan, normal upper pool el 814, gate 3 open 6 ft

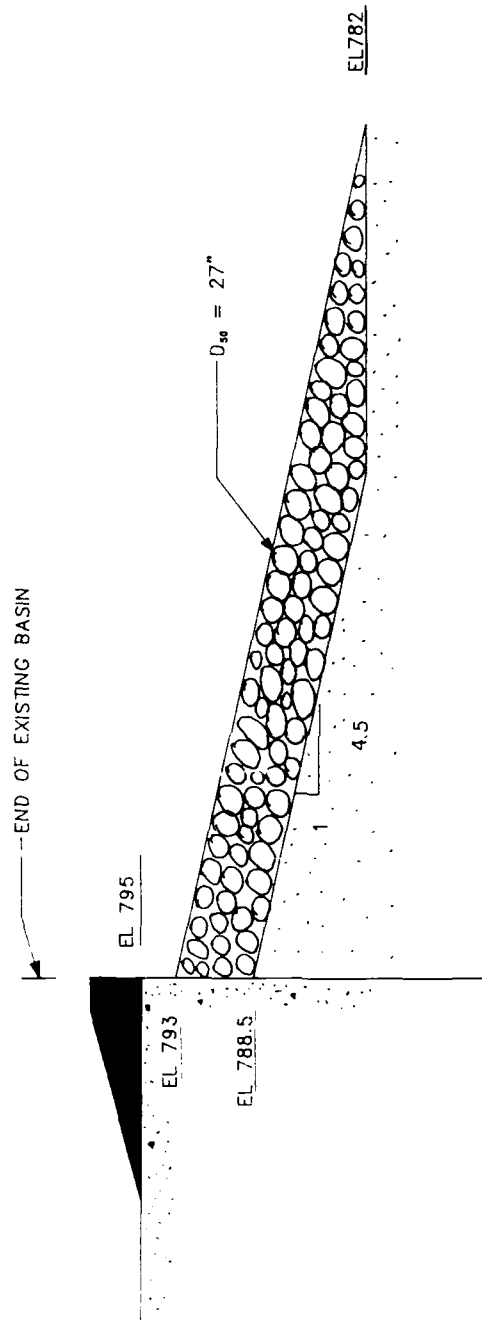

TYPE 1 RIPRAP PLAN

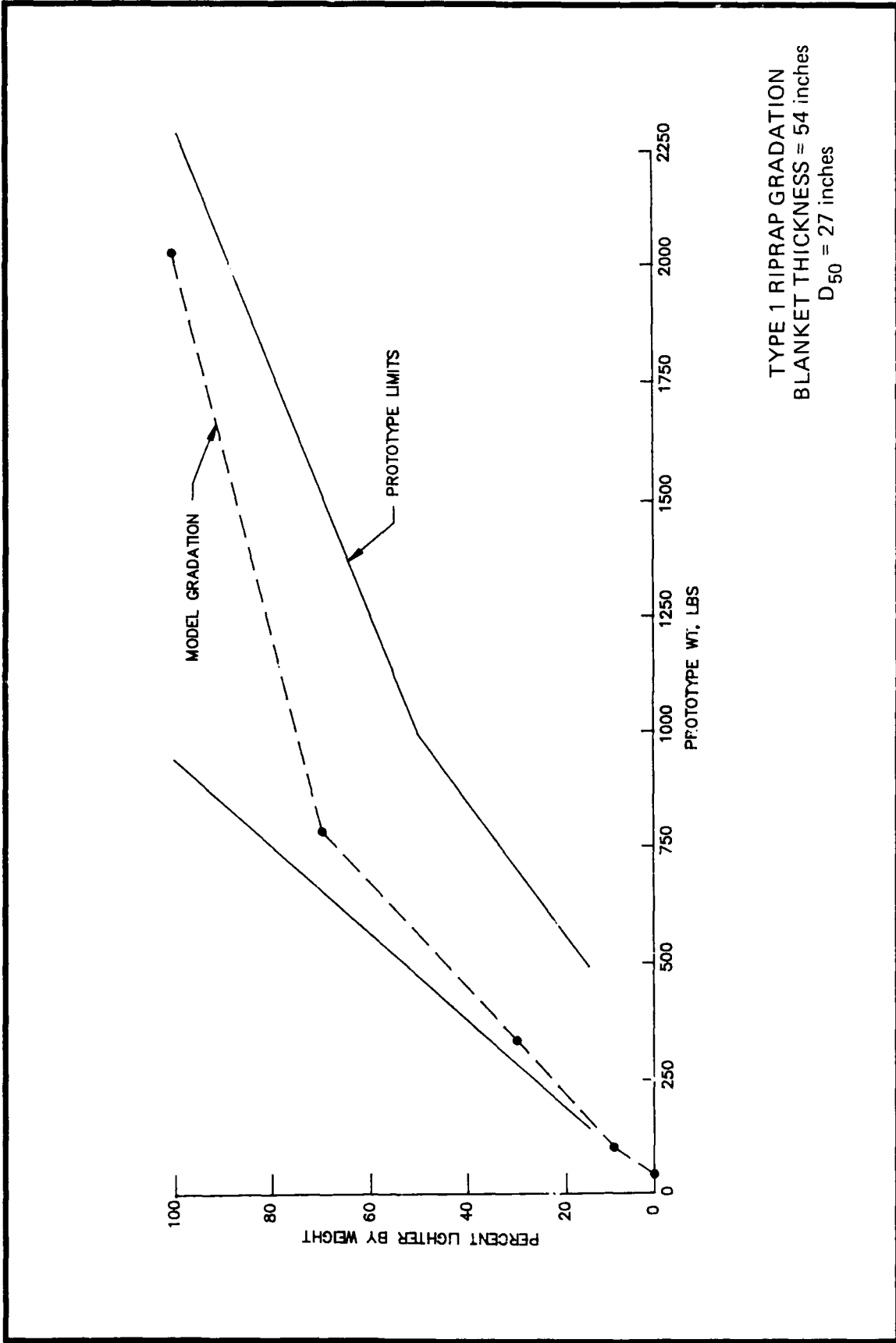
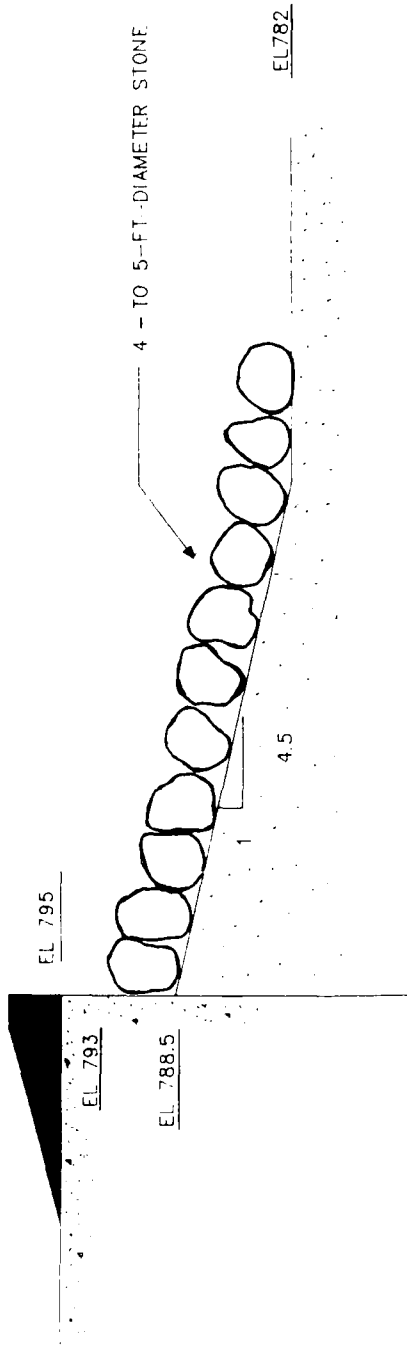
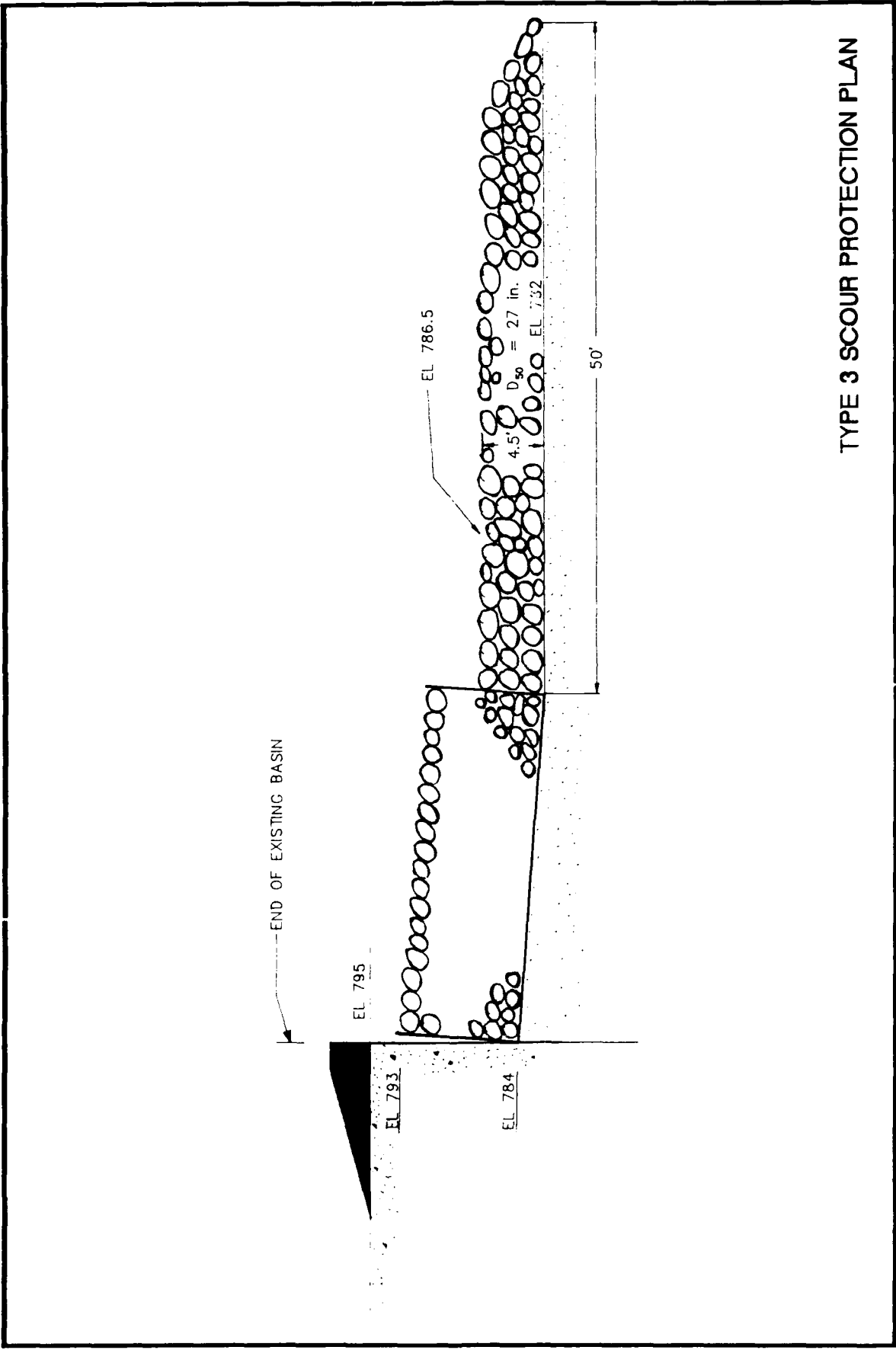

PLATE 2

END OF EXISTING BASIN



TYPE 2 RIPRAP PLAN



TYPE 3 SCOUR PROTECTION PLAN

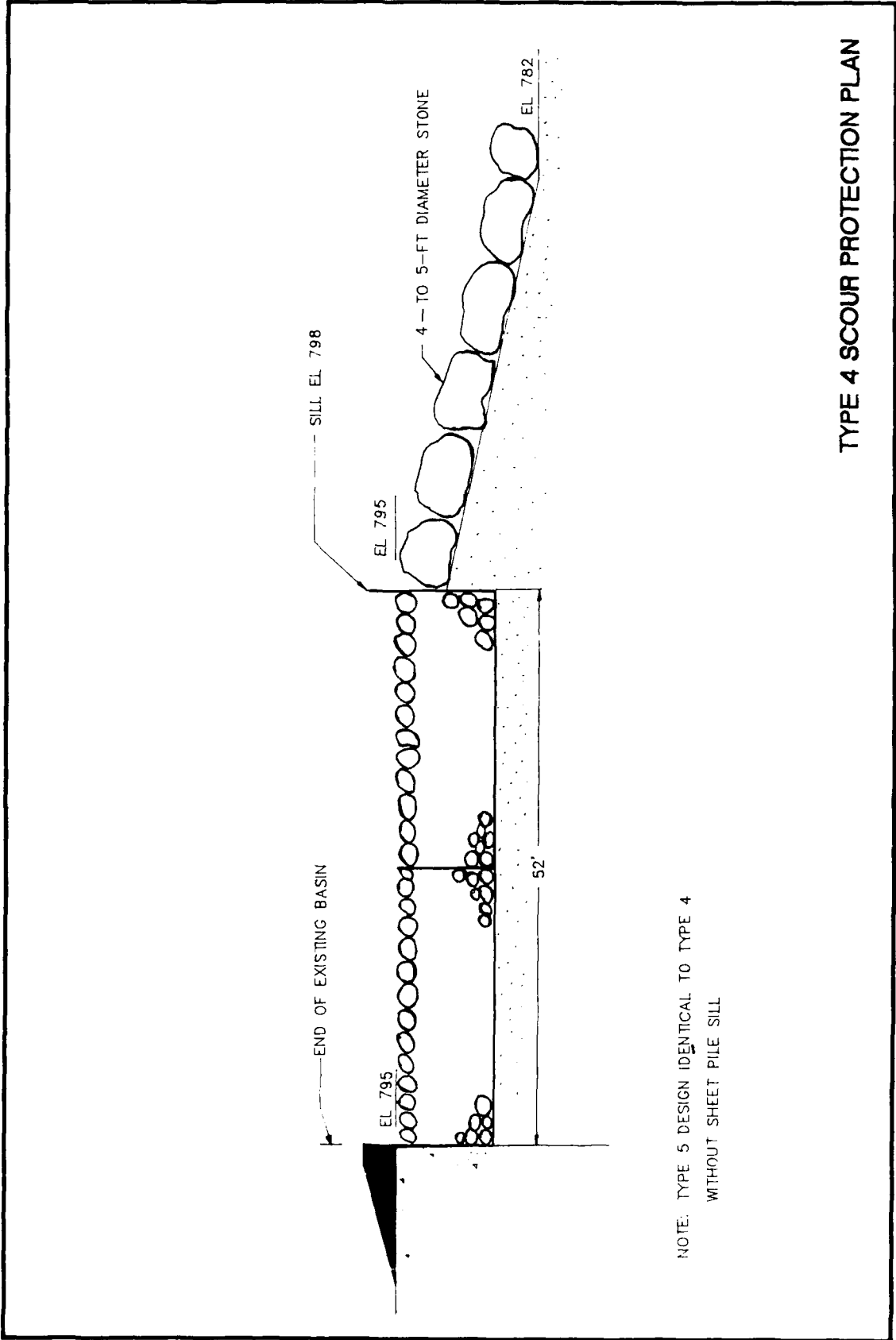

TYPE 4 SCOUR PROTECTION PLAN

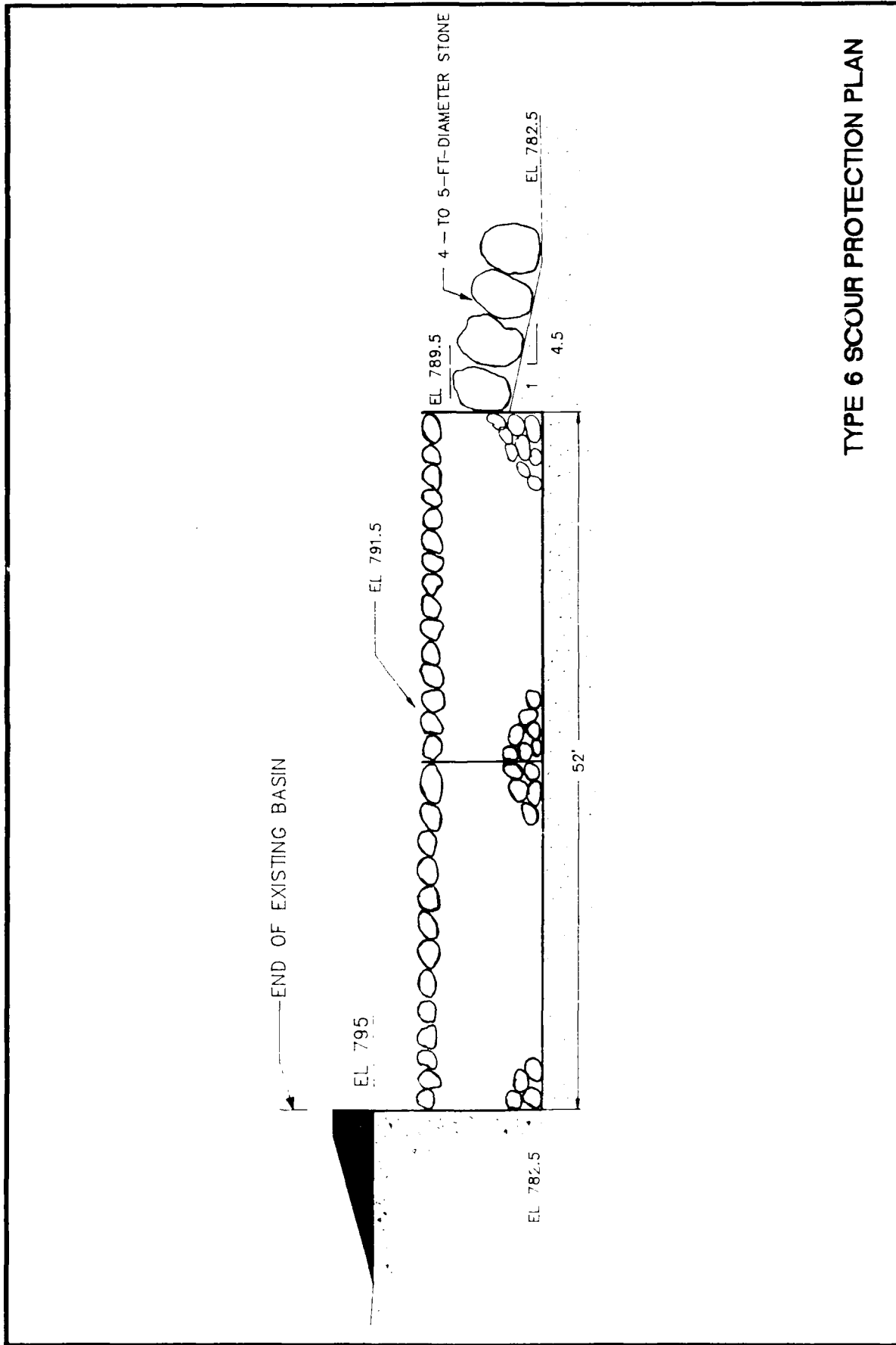

TYPE 6 SCOUR PROTECTION PLAN

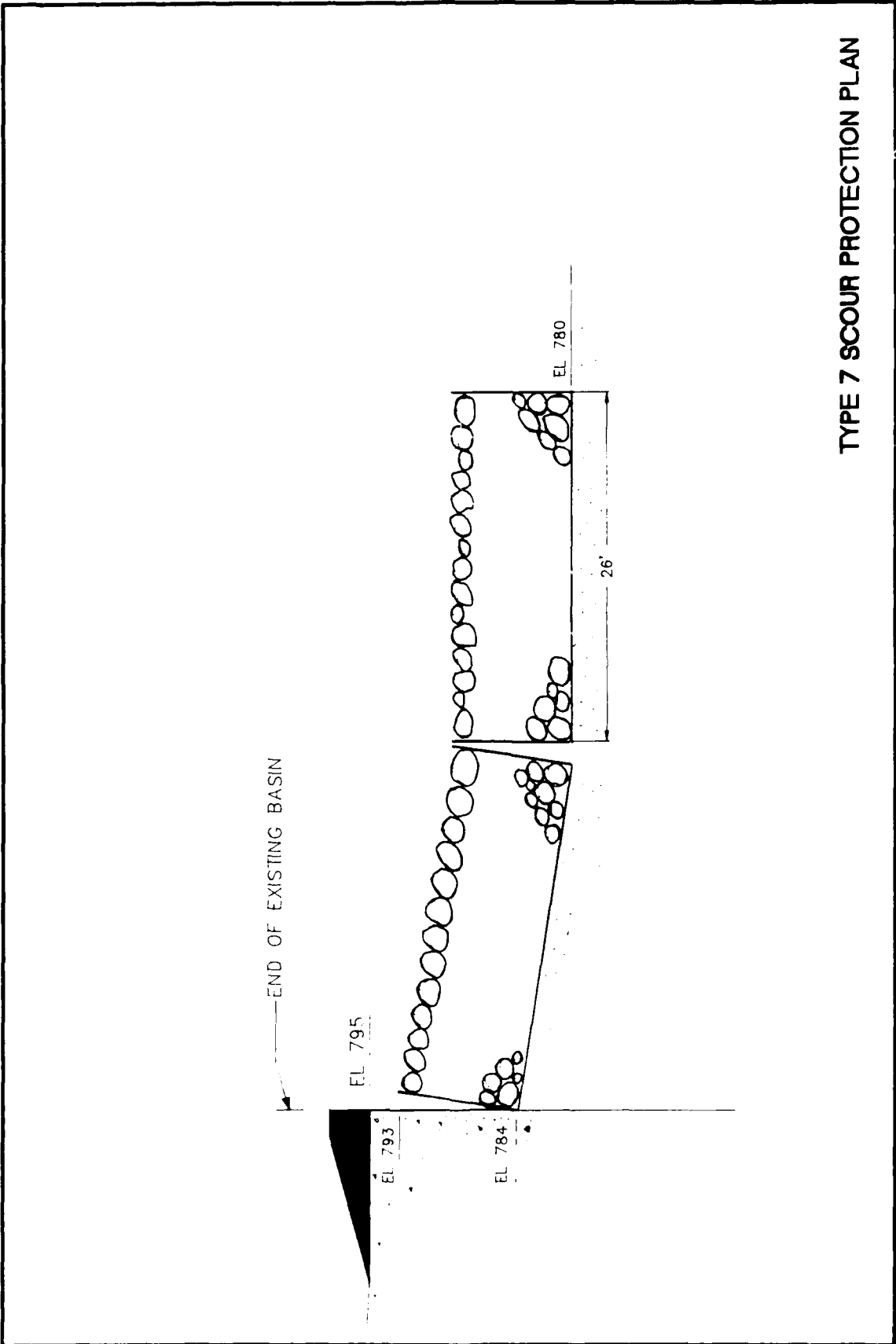

TYPE 7 SCOUR PROTECTION PLAN

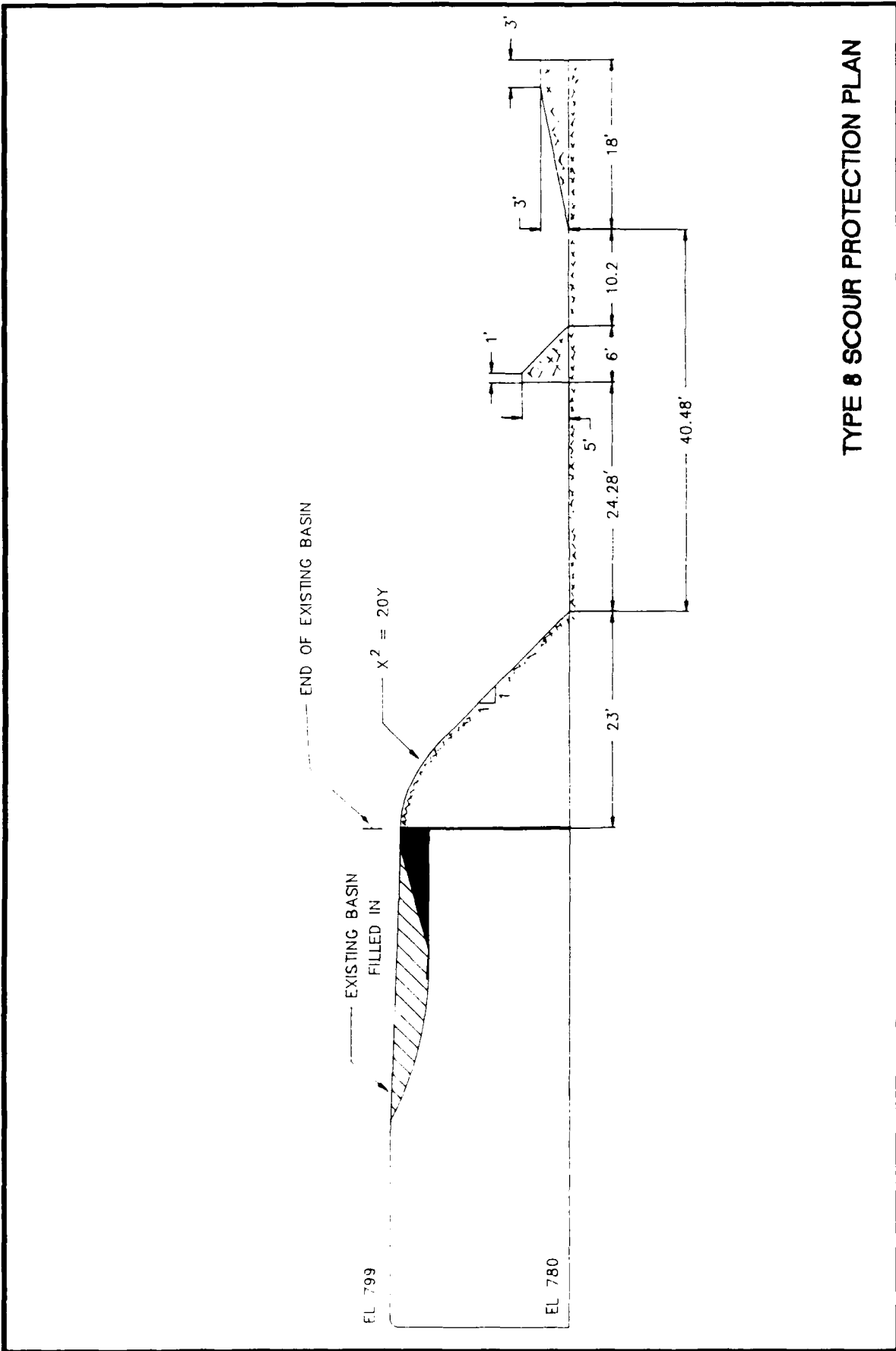

TYPE 8 SCOUR PROTECTION PLAN

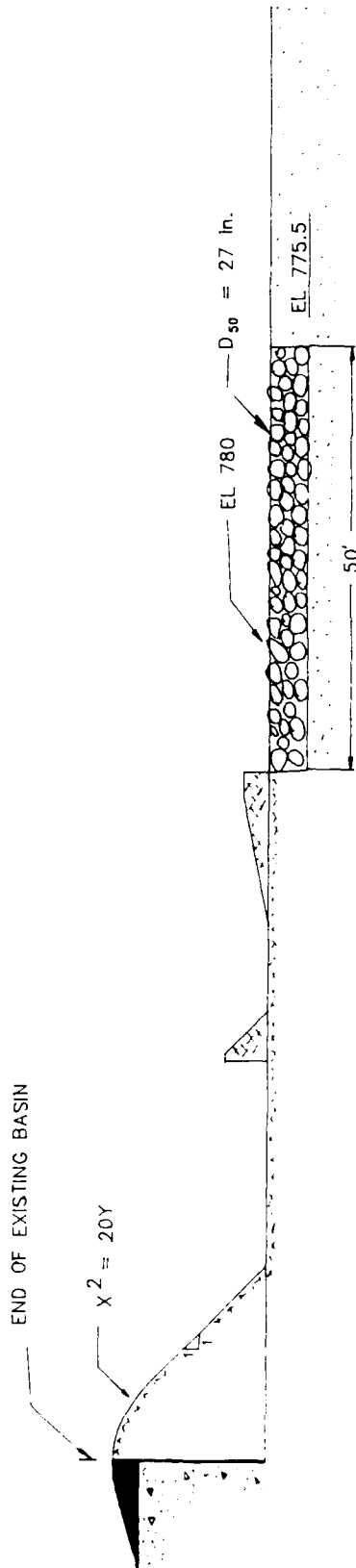

NOTE: DETAILS OF BASIN SAME AS TYPE 8 DESIGN

TYPE 9 SCOUR PROTECTION PLAN

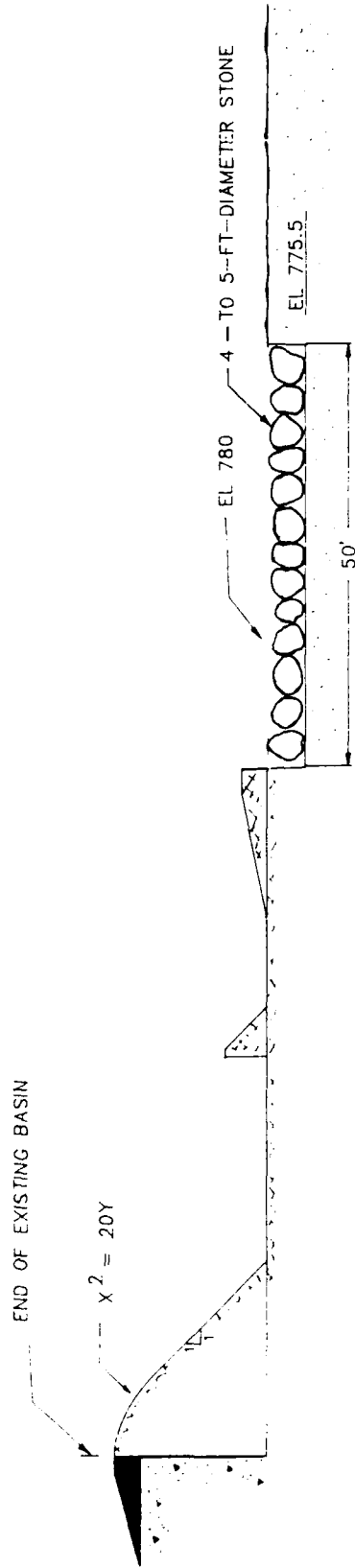

NOTE: DETAILS OF BASIN SAME AS TYPE 8 DESIGN

TYPE 10 SCOUR PROTECTION PLAN

END OF EXISTING BASIN

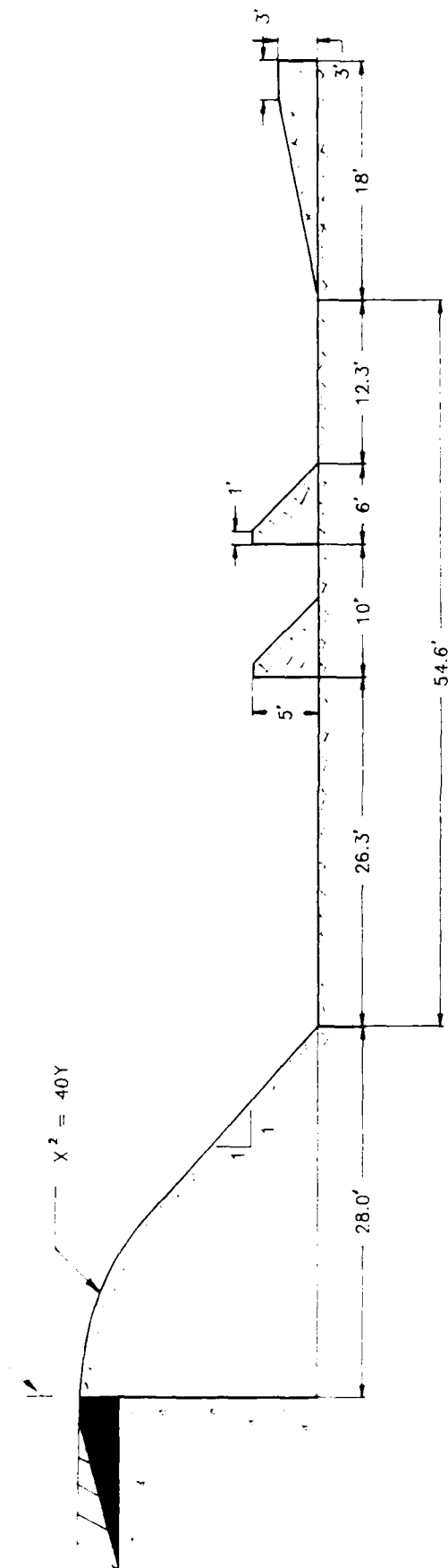

TYPE 11 SCOUR PROTECTION PLAN

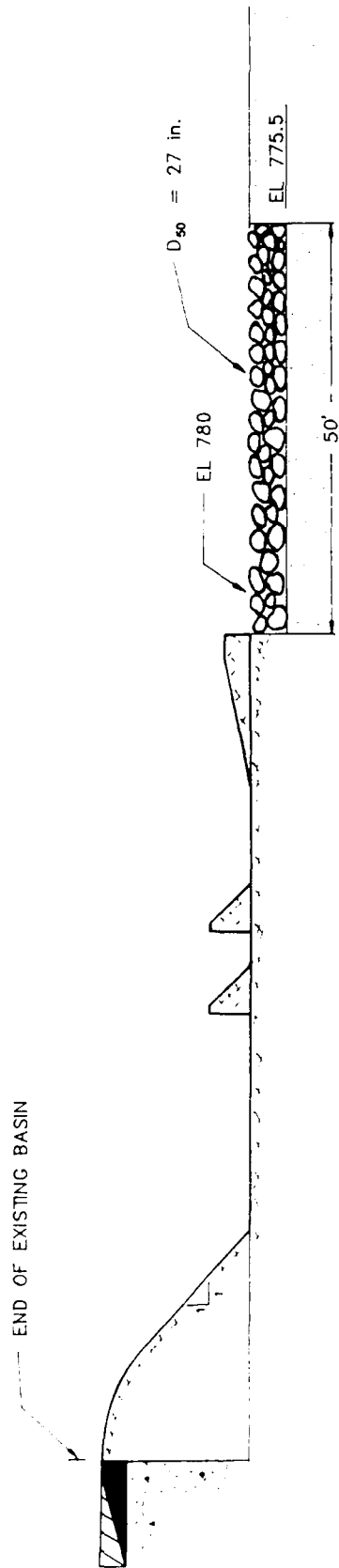

NOTE: DETAILS OF BASIN SAME AS TYPE 11 DESIGN

TYPE 12 SCOUR PROTECTION PLAN

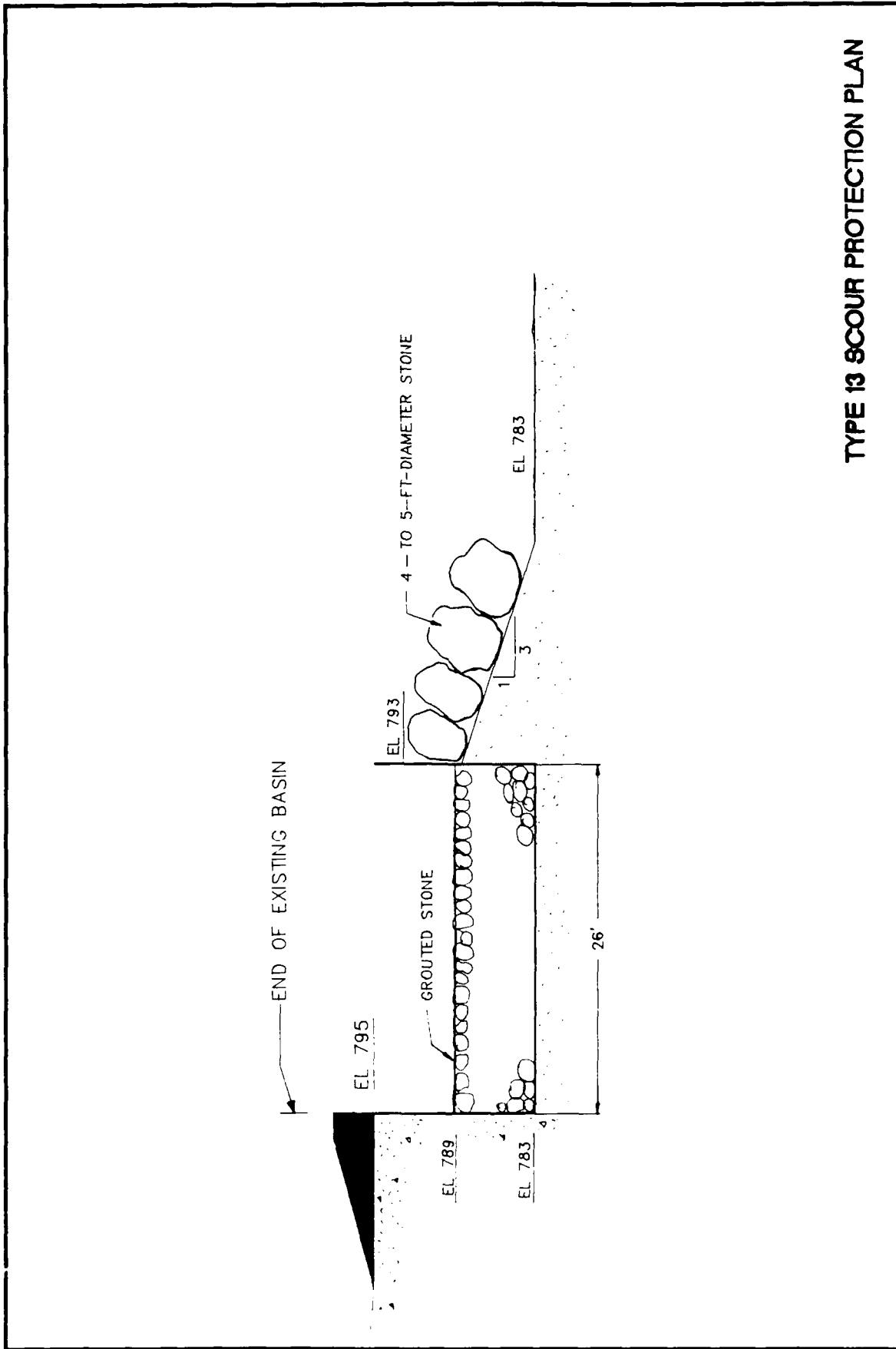

TYPE 13 SCOUR PROTECTION PLAN

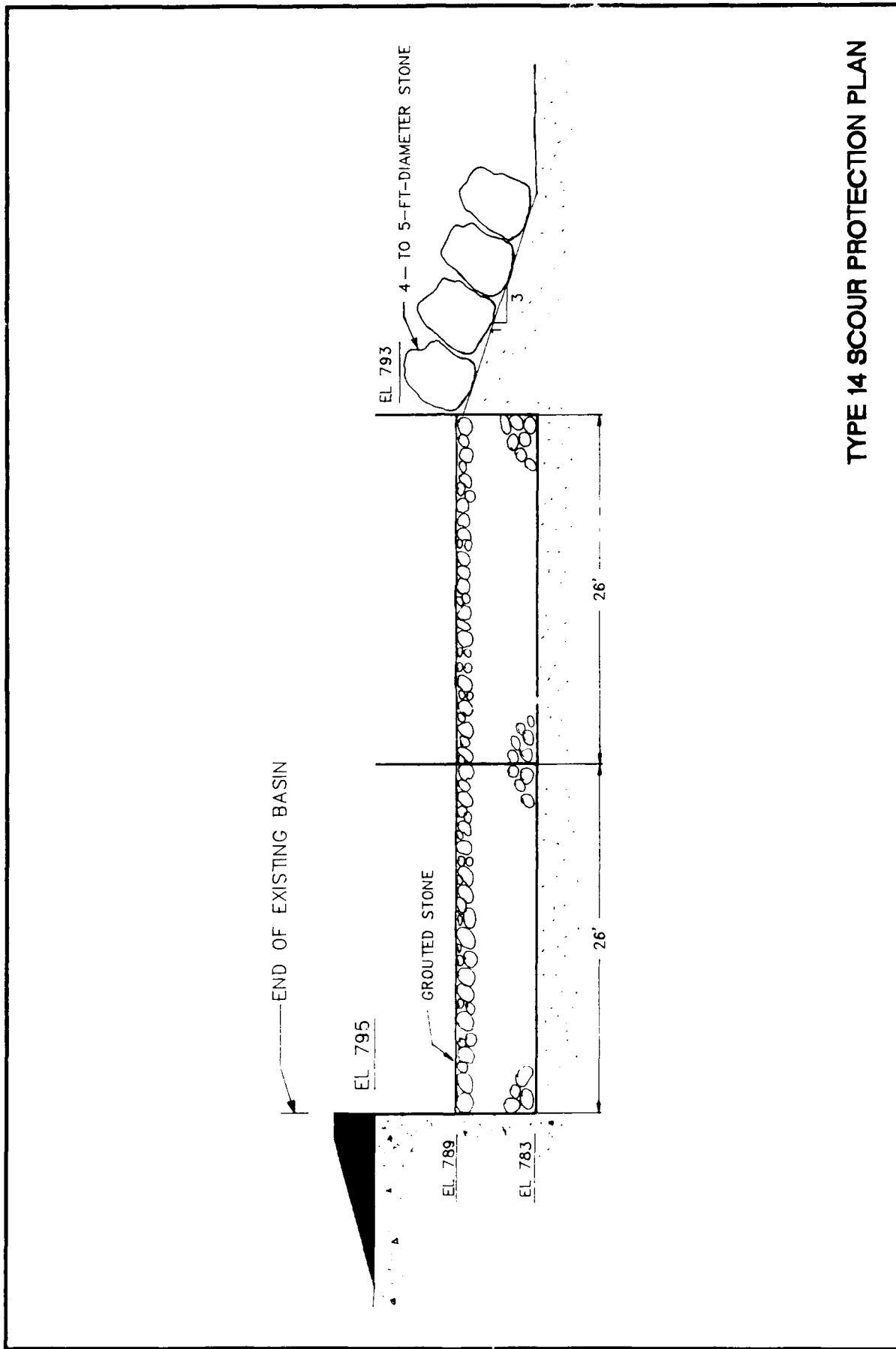

TYPE 14 SCOUR PROTECTION PLAN

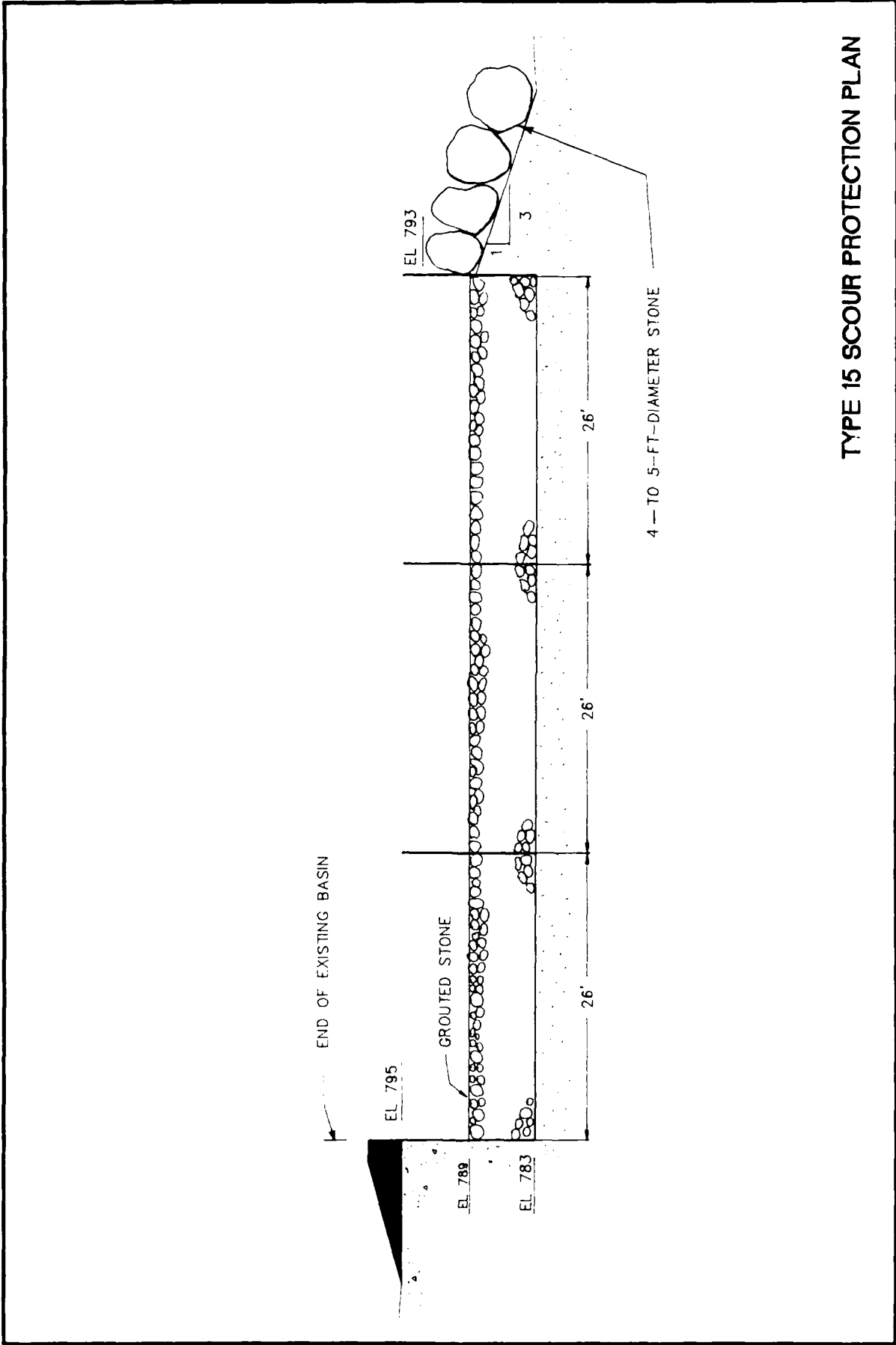

TYPE 15 SCOUR PROTECTION PLAN

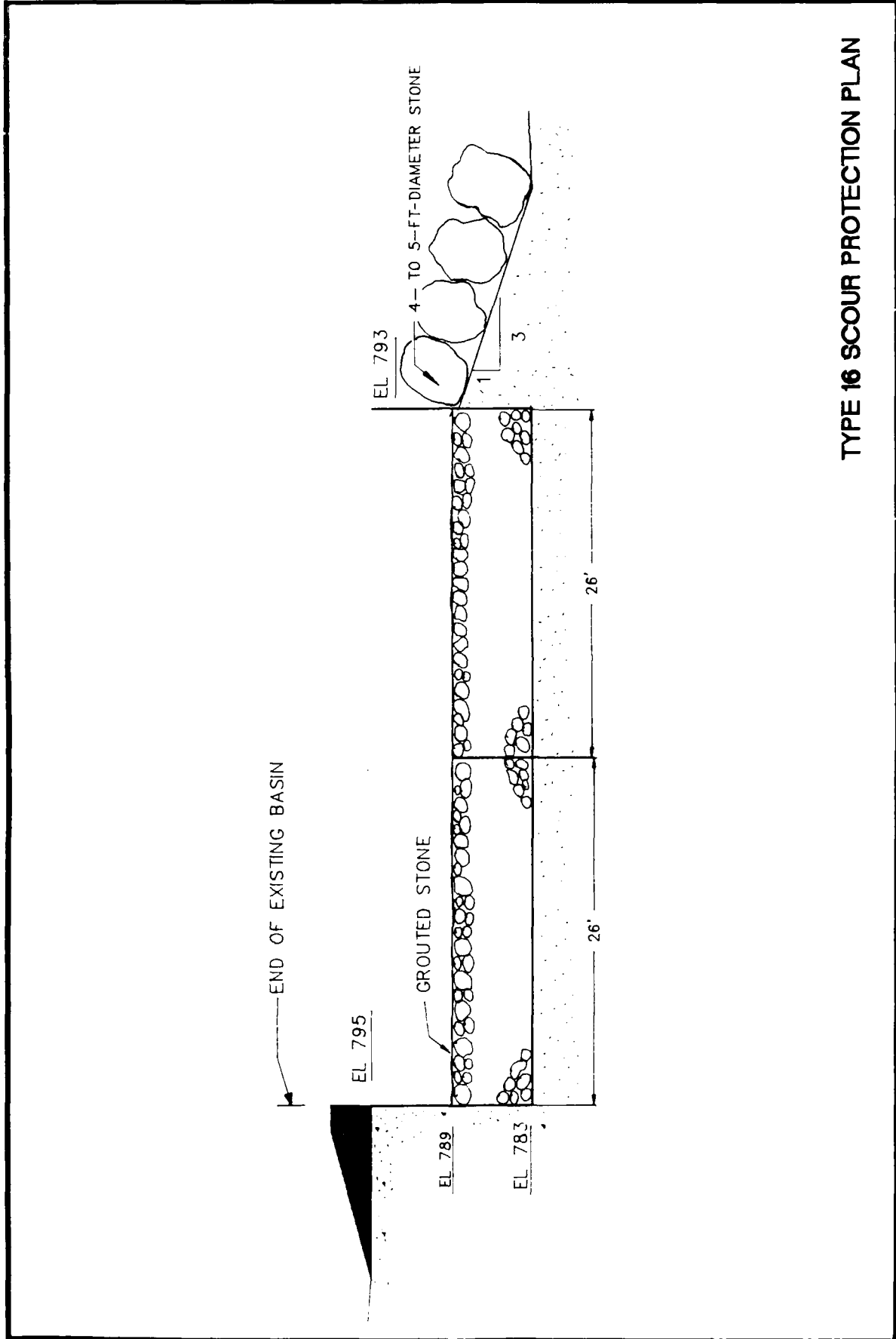

TYPE 16 SCOUR PROTECTION PLAN

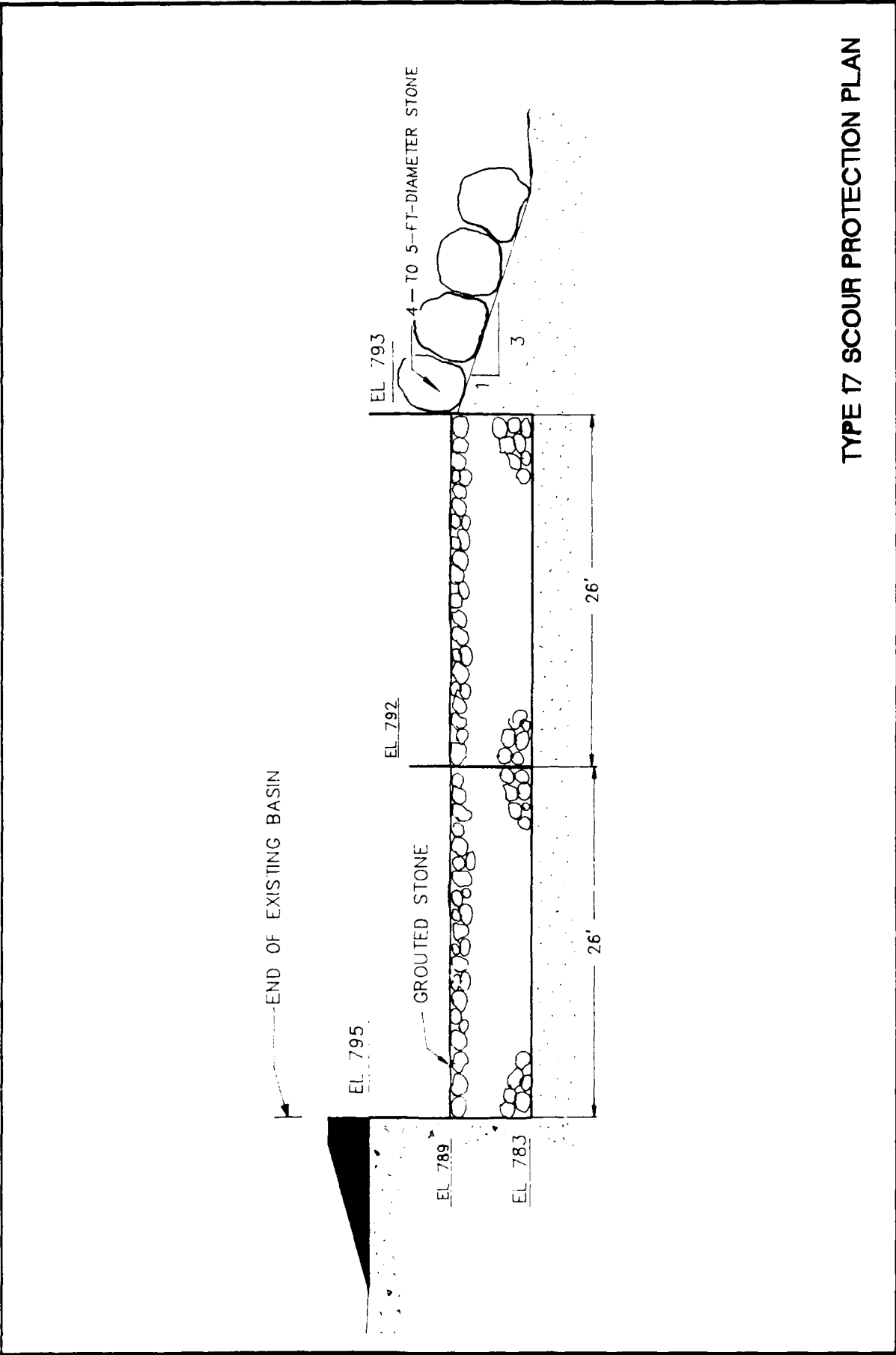

TYPE 17 SCOUR PROTECTION PLAN

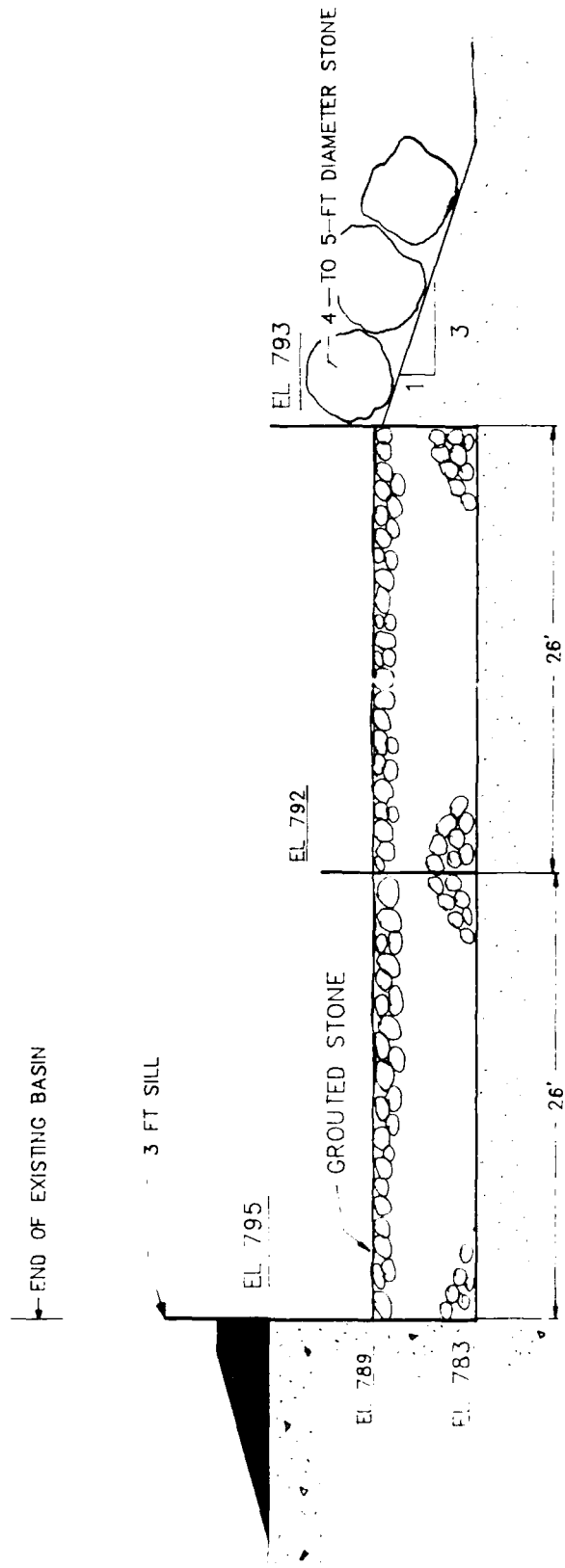

TYPE 18 SCOUR PROTECTION PLAN

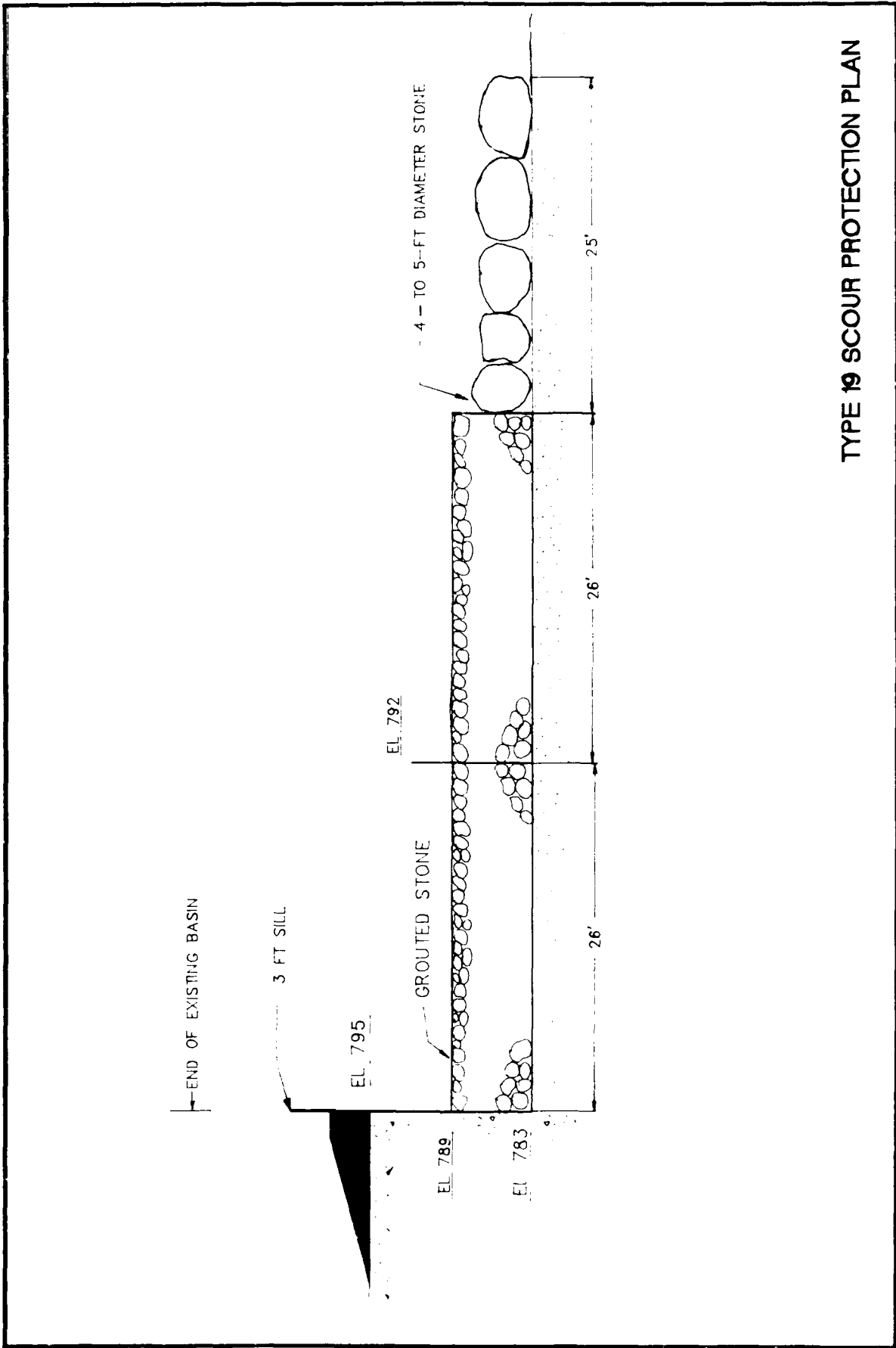

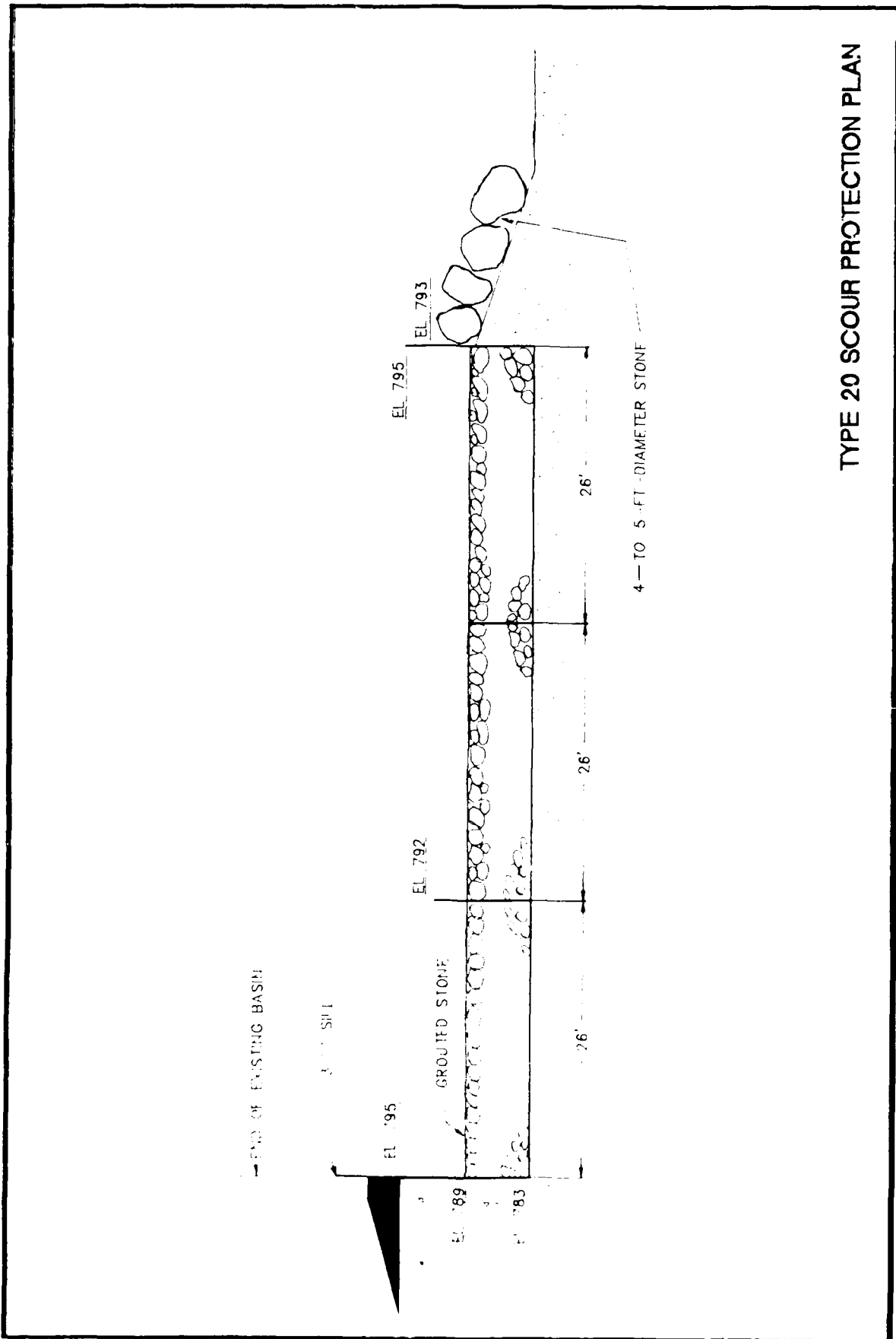

TYPE 20 SCOUR PROTECTION PLAN

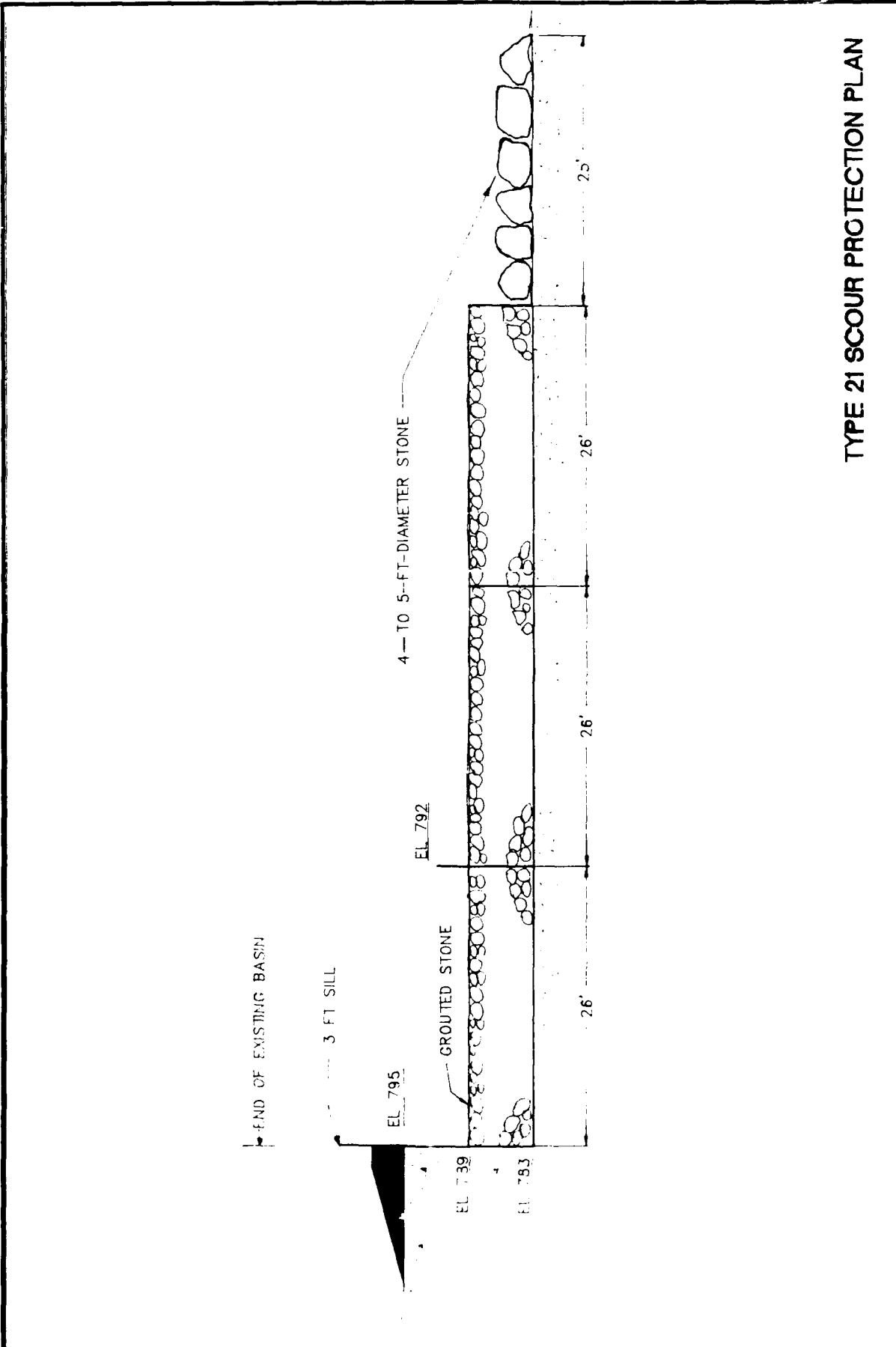

TYPE 21 SCOUR PROTECTION PLAN

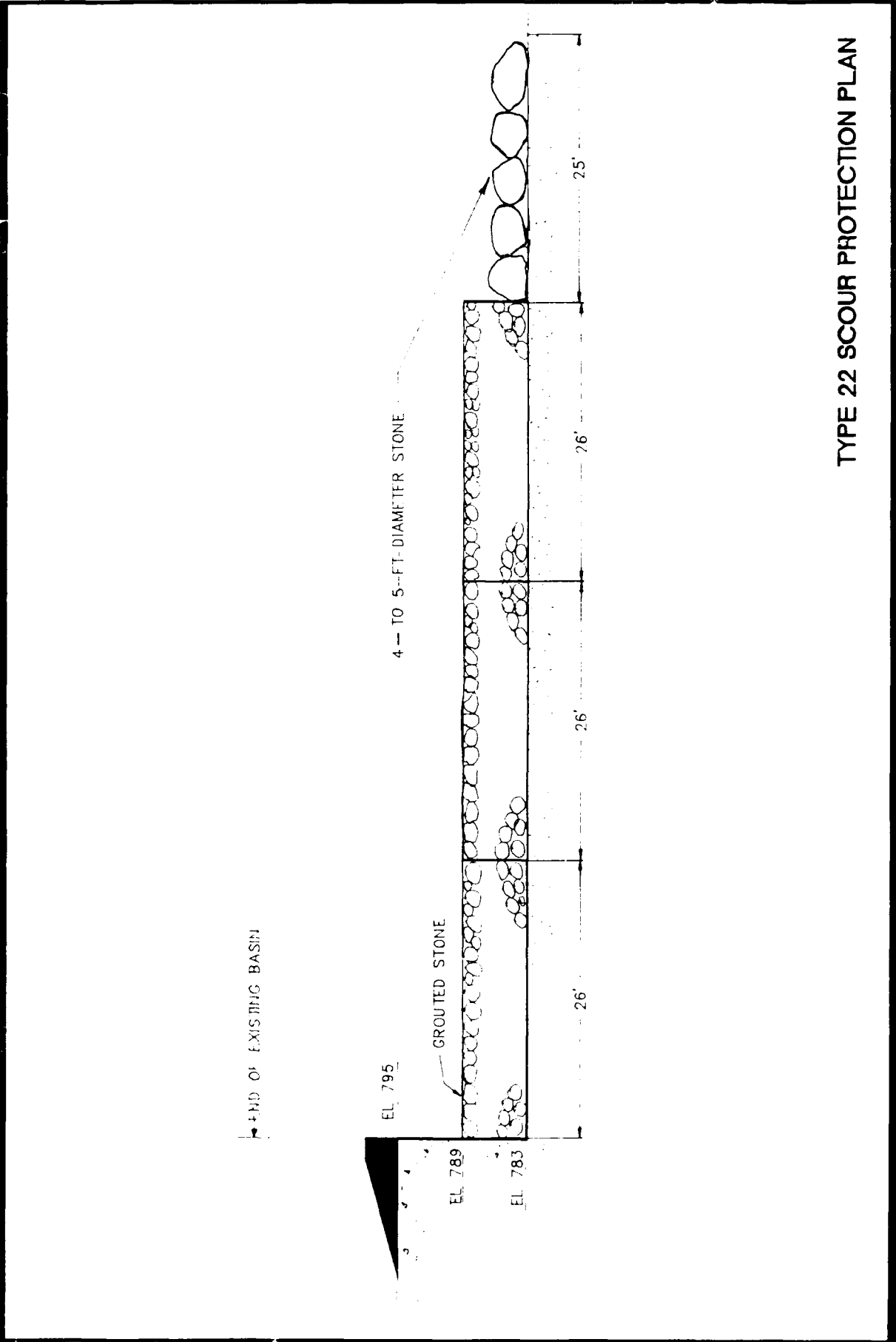

TYPE 22 SCOUR PROTECTION PLAN

END OF EXISTING BASIN

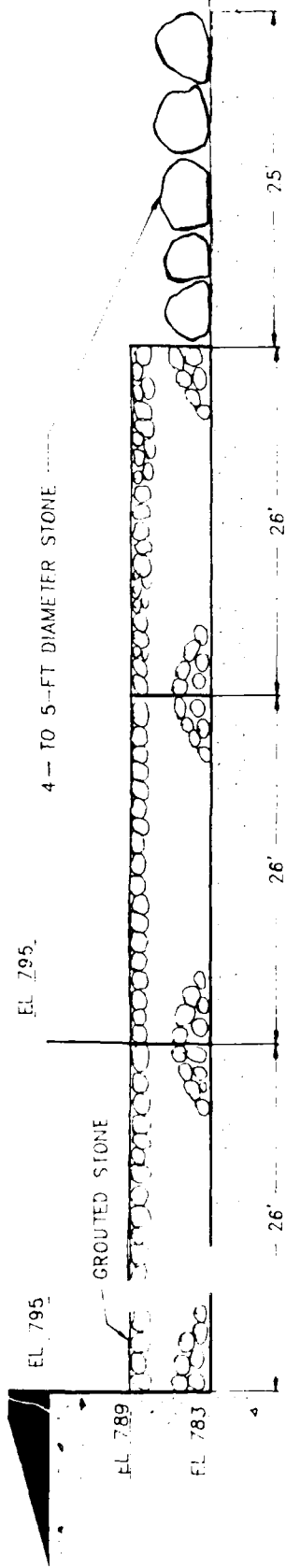

TYPE 23 SCOUR PROTECTION PLAN

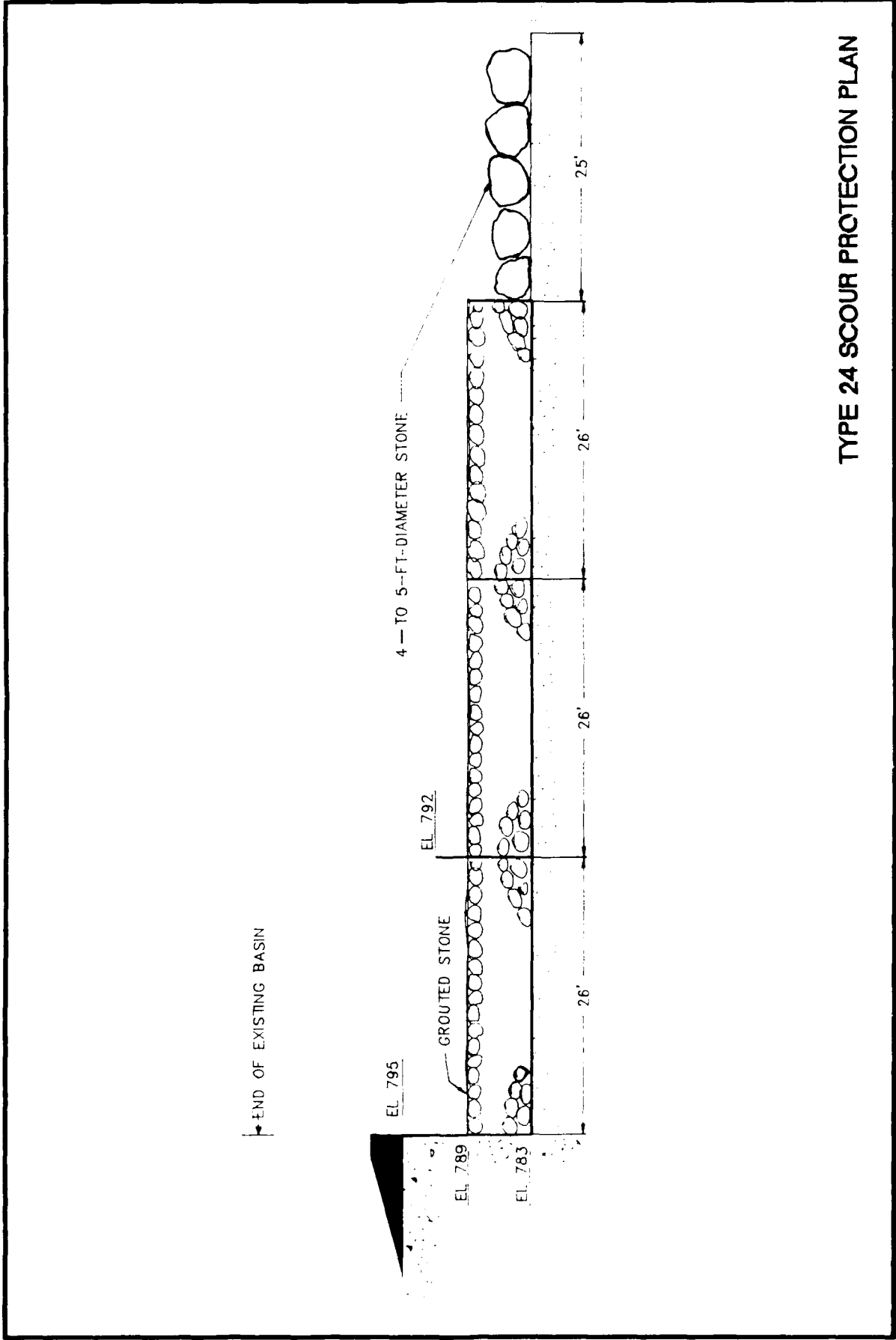

TYPE 24 SCOUR PROTECTION PLAN

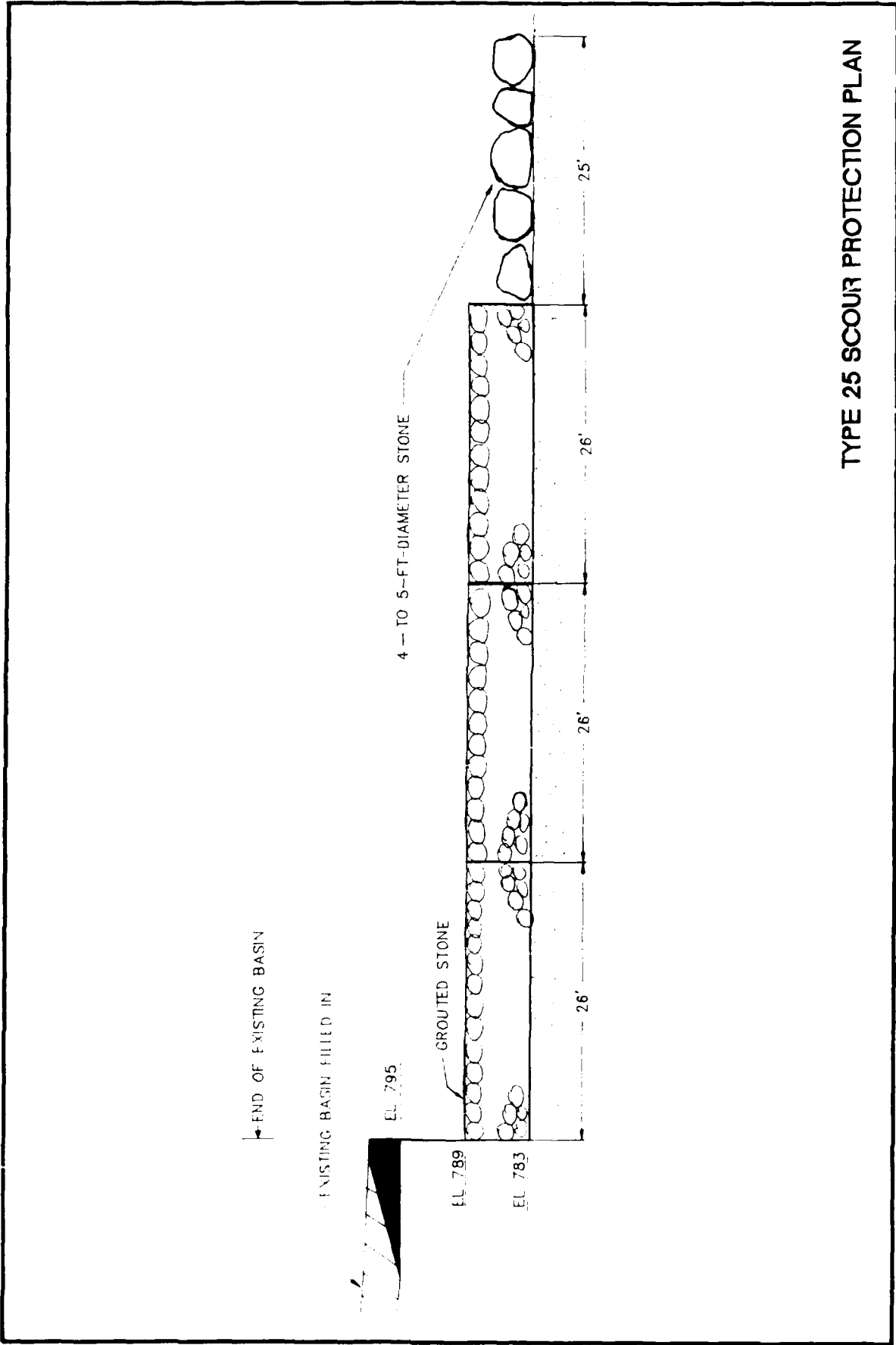

TYPE 25 SCOUR PROTECTION PLAN

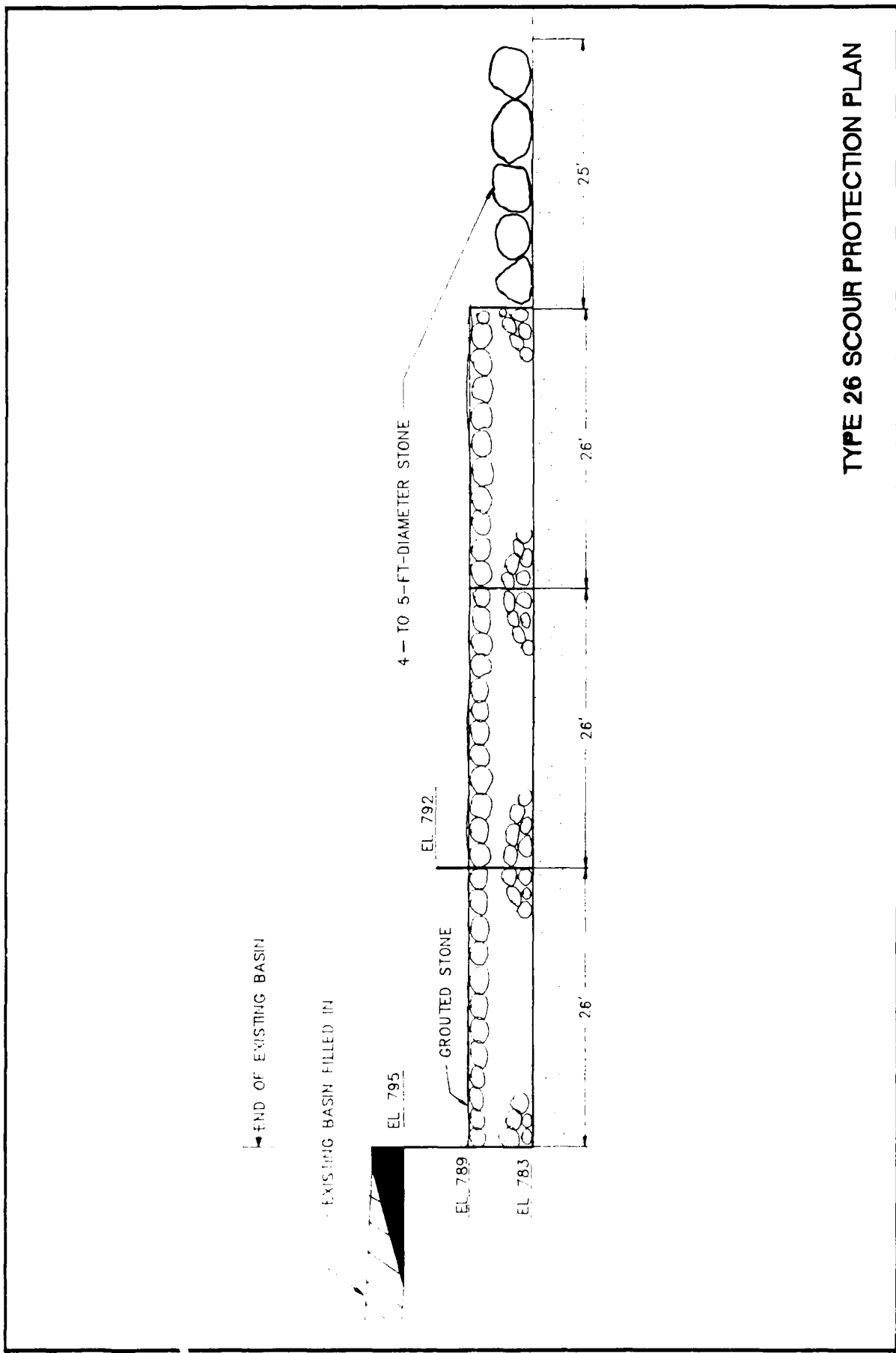

TYPE 26 SCOUR PROTECTION PLAN

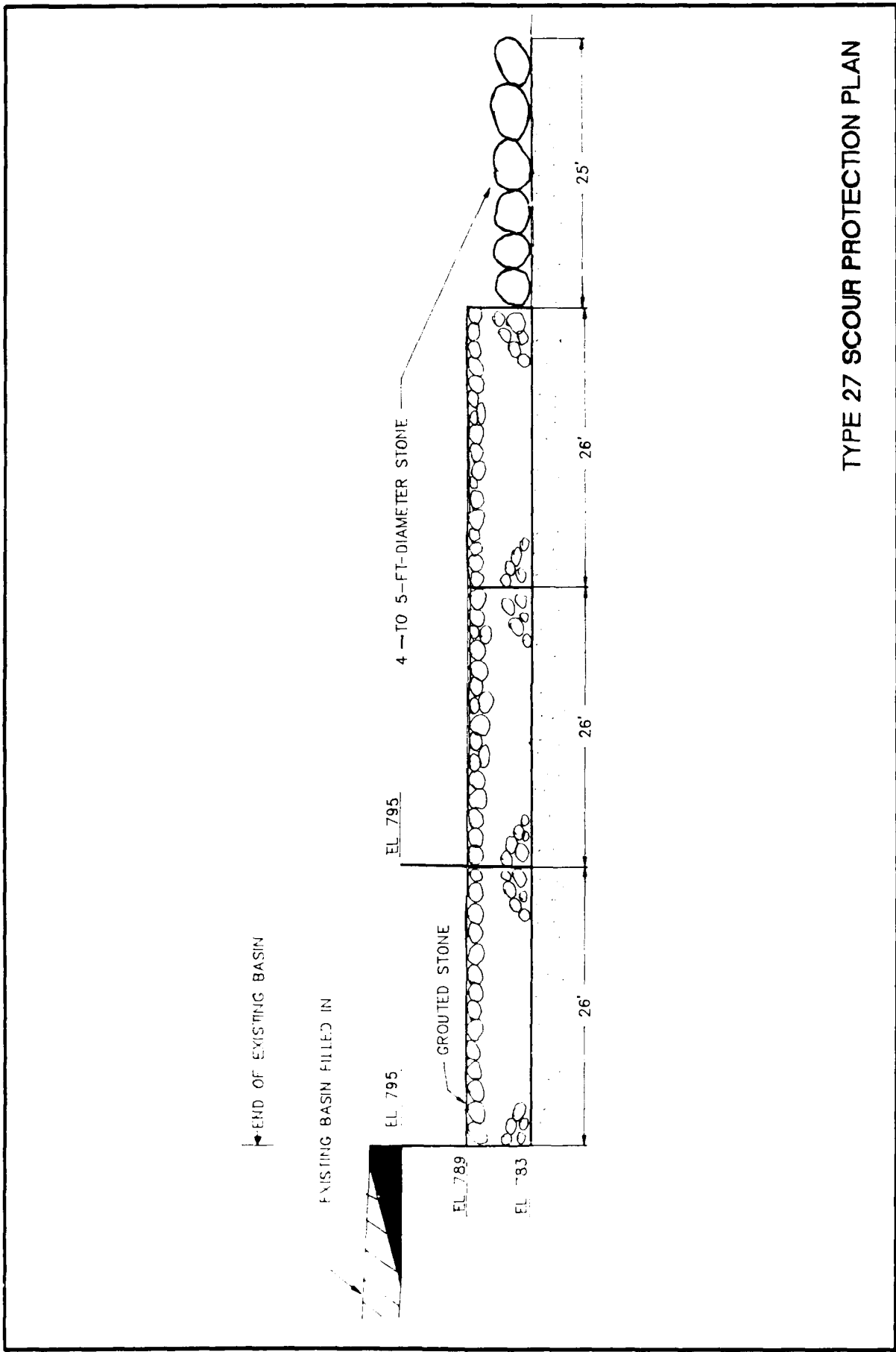

TYPE 27 SCOUR PROTECTION PLAN