

AIR FORCE



AD-A212 767

HUMAN

RESOURCES

**AIR FORCE RETENTION ANALYSIS PACKAGE:
USERS MANUAL**

**Brice M. Stone
Rebecca A. Wortman**

**RRC, Inc.
3833 Texas Avenue, Suite 256
Bryan, Texas 77802**

Larry T. Looper

**MANPOWER AND PERSONNEL DIVISION
Brooks Air Force Base, Texas 78235-5601**

August 1989

Final Technical Paper for Period November 1987 - November 1988

Approved for public release; distribution is unlimited.

LABORATORY

S **D** **D**
DTC
ELECTE
SEP 18 1989

**AIR FORCE SYSTEMS COMMAND
BROOKS AIR FORCE BASE, TEXAS 78235-5601**

89 9 15 012

NOTICE

When Government drawings, specifications, or other data are used for any purpose other than in connection with a definitely Government-related procurement, the United States Government incurs no responsibility or any obligation whatsoever. The fact that the Government may have formulated or in any way supplied the said drawings, specifications, or other data, is not to be regarded by implication, or otherwise in any manner construed, as licensing the holder, or any other person or corporation; or as conveying any rights or permission to manufacture, use, or sell any patented invention that may in any way be related thereto.

The Public Affairs Office has reviewed this paper, and it is releasable to the National Technical Information Service, where it will be available to the general public, including foreign nationals.

This paper has been reviewed and is approved for publication.

WILLIAM E. ALLEY, Technical Director
Manpower and Personnel Division

DANIEL L. LEIGHTON, Colonel, USAF
Chief, Manpower and Personnel Division

SECURITY CLASSIFICATION OF THIS PAGE

REPORT DOCUMENTATION PAGE				Form Approved OMB No. 0704-0188	
1a. REPORT SECURITY CLASSIFICATION Unclassified		1b. RESTRICTIVE MARKINGS			
2a. SECURITY CLASSIFICATION AUTHORITY		3. DISTRIBUTION / AVAILABILITY OF REPORT Approved for public release; distribution is unlimited.			
2b. DECLASSIFICATION / DOWNGRADING SCHEDULE					
4. PERFORMING ORGANIZATION REPORT NUMBER(S)		5. MONITORING ORGANIZATION REPORT NUMBER(S) AFHRL-TP-89-10			
6a. NAME OF PERFORMING ORGANIZATION RRC, Inc.		6b. OFFICE SYMBOL (If applicable)		7a. NAME OF MONITORING ORGANIZATION Manpower and Personnel Division	
6c. ADDRESS (City, State, and ZIP Code) 3833 Texas Avenue, Suite 256 Bryan, Texas 77801		7b. ADDRESS (City, State, and ZIP Code) Air Force Human Resources Laboratory Brooks Air Force Base, Texas 78235-5601			
8a. NAME OF FUNDING / SPONSORING ORGANIZATION Air Force Human Resources Laboratory		8b. OFFICE SYMBOL (If applicable) HQ AFHRL		9. PROCUREMENT INSTRUMENT IDENTIFICATION NUMBER F41800-88-M0783	
8c. ADDRESS (City, State, and ZIP Code) Brooks Air Force Base, Texas 78235-5601		10. SOURCE OF FUNDING NUMBERS			
		PROGRAM ELEMENT NO. 62205F	PROJECT NO. 7719	TASK NO. 20	WORK UNIT ACCESSION NO. 07
11. TITLE (Include Security Classification) Air Force Retention Analysis Package: Users Manual					
12. PERSONAL AUTHOR(S) Stone, B.M.; Wortman, R.A.; Looper, L.T.					
13a. TYPE OF REPORT Final		13b. TIME COVERED FROM <u>Nov 87</u> TO <u>Nov 88</u>		14. DATE OF REPORT (Year, Month, Day) August 1989	
				15. PAGE COUNT 68	
16. SUPPLEMENTARY NOTATION					
17. COSATI CODES			18. SUBJECT TERMS (Continue on reverse if necessary and identify by block number)		
FIELD	GROUP	SUB-GROUP	computer model; reenlistment decision making		
05	03		econometric model;		
05	10		enlisted retention		
19. ABSTRACT (Continue on reverse if necessary and identify by block number) In an effort to aid Air Force decision-makers in evaluating the effects of various demographic, economic, and policy effects on reenlistment within an enlisted Air Force specialty (AFS), the Air Force Retention Analysis Package (AFRAP) was developed. It provides manpower and personnel decision-makers with information on the reenlistment behavior of individuals, given changes in the Air Force environment or the national economy, and projects the effects on the AFS structure of the predicted reenlistment behavior of first-term, second-term, and career enlisted personnel. AFRAP is divided into two modules: the Reenlistment Analysis Package (RAP) and the Year of Service (YOS). RAP allows the decision-maker to vary the conditions under which enlisted members would make their reenlistment decisions. The RAP subsystem then reports the reenlistment rates based upon the model's demographic, economic or policy variables. The YOS module uses reenlistment rates provided by RAP or directly from the user, converts them into retention rates, and then ages the force by a user-determined number of years. The YOS subsystem then prints a list of summary statistics detailing how the force structure evolved.					
20. DISTRIBUTION / AVAILABILITY OF ABSTRACT <input checked="" type="checkbox"/> UNCLASSIFIED/UNLIMITED <input type="checkbox"/> SAME AS RPT <input type="checkbox"/> DTIC USERS			21. ABSTRACT SECURITY CLASSIFICATION Unclassified		
22a. NAME OF RESPONSIBLE INDIVIDUAL Nancy J. Ailin, Chief, STINFO Branch			22b. TELEPHONE (Include Area Code) (512) 536-3877		22c. OFFICE SYMBOL AFHRL/SCV

AIR FORCE RETENTION ANALYSIS PACKAGE: USERS MANUAL

**Brice M. Stone
Rebecca A. Wortman**

**RRC, Inc.
3833 Texas Avenue, Suite 256
Bryan, Texas 77802**

**MANPOWER AND PERSONNEL DIVISION
Brooks Air Force Base, Texas 78235-5601**

Reviewed by

**Larry T. Looper
Chief, Decision Models Function**

Submitted for publication by

**David E. Brown, Lt Col, USAF
Chief, Force Management Systems Branch**

Accession For	
NTIS CRA&I	<input checked="" type="checkbox"/>
DTIC TAB	<input type="checkbox"/>
Unannounced	<input type="checkbox"/>
Justification	
By _____	
Distribution/	
Availability Codes	
Dist	Avail and/or Special
A-1	



SUMMARY

This report discusses the Air Force Retention Analysis Package (AFRAP), a computer-based force analysis and policy modeling software tool for use by Air Force personnel decision-makers and planners. AFRAP was designed for use on the microcomputer and is divided into two modules: the Reenlistment Analysis Package (RAP) module and the Year of Service (YOS) force projection module. These two modules can operate separately or independently, as determined by the user. RAP provides the user the opportunity to vary economic and demographic variables for enlisted decision-makers and calculates the corresponding reenlistment rate for the Air Force specialty (AFS) and reenlistment term selected. It will also calculate the selective reenlistment bonus required to achieve a desired reenlistment rate in an AFS.

The YOS module provides the option to study the impact of various retention scenarios on the force structure in a particular AFS. The user can employ reenlistment rates determined in RAP or modified historical retention patterns, adjust the beginning force structure, or change the desired number of people in the AFS.

This manual provides a description of how these two modules operate and interrelate by guiding the user through each screen with an input and output example and explanation of options available. In addition, the manual provides an in-depth explanation of the underlying econometric model.

PREFACE

The computer model discussed in this manual was developed as a part of the Manpower and Personnel Division's Force Management research and development program. Development of this computer model will improve the ability of Air Force personnel managers to make more informed decisions as to the effects of various demographic and/or economic variables on the retention of enlisted personnel at the 5-digit Air Force Specialty Code level.

The authors wish to thank Mrs. Barbara Randall for her programming of the AFRAP computer mode, Dr. Thomas R. Saving and Dr. Guy Curry for technical assistance and guidance in this research project, Mrs. Kathy Berry and her staff for typing and editing the manual, and 1Lt John McGarrity for his technical review of the computer program and this manual.

TABLE OF CONTENTS

		Page
I.	INTRODUCTION	1
II.	REENLISTMENT ANALYSIS PACKAGE(RAP)	1
III.	YEAR OF SERVICE (YOS) ANALYSIS	12
IV.	INTEGRATION OF RAP AND YOS	32
	REFERENCES	34
	APPENDIX A: A Model of Enlisted Retention	35
	APPENDIX B: List of AFSs in AFRAP	39
	APPENDIX C: A Mathematical Approximation of the Probit Estimation Function	44
	APPENDIX D: Prior-Service Accessions	45
	APPENDIX E: Length of Service Distribution Graph	46
	APPENDIX F: Calculation of Continuation Rates	49
	APPENDIX G: Detailed Discussion of Output Tables	52

LIST OF FIGURES

Figure		Page
1	Reenlistment Analysis Package (RAP)	2
2	Screen 1	4
3	Screen 2	6
4	Screen 3	8
5	Screen 4	11
6	Year of Service (YOS) Analysis	13
7	Screen 5	15
8	Screen 5a	18
9	Screen 5b	20
10	Screen 6	22
11	Screen 6a	25
12	Screen 7	27
13	Screen 7a	29
14	Screen 7b	31
15	Integration of RAP and YOS	33
E-1	Length of Service Distribution Line Graph	47
E-2	Length of Service Distribution Bar Graph	48
G-1	Summary Table	53
G-2	Year-by-Year Projection Table	55
G-3	Year of Service Distribution Table	58
G-4	Reenlistment Comparison Table	61

LIST OF TABLES

Table		Page
F-1	Continuation Rates by Year of Service	50

I. INTRODUCTION

The Air Force Retention Analysis Package (AFRAP) is a menu-driven, user-friendly software package designed for the analysis of changes in reenlistment decision behavior and their impact on the experience structure in a specific Air Force Specialty (AFS). The package is comprised of two parts:

1. Reenlistment Analysis Package (RAP) and
2. Year of Service (YOS) Analysis.

RAP provides the user with the ability to vary demographic and economic conditions such as academic education level, unemployment rate, and military and civilian pay to analyze the effects on reenlistment rates by each of three categories of enlistment. The first-term category models reenlistment decisions made from 36 months of service to 6 years of service, the second-term category includes decisions from 6 to 10 years of service, and the career category models decisions from 10 to 14 years of service. In addition, the user can determine the necessary Selective Reenlistment Bonus (SRB) multiple for attaining a desired reenlistment rate.

YOS provides the user with the capability to age an existing length of service inventory in a particular AFS. The user can examine the experience distribution of an AFS once it is older and has experienced attrition. This is possible by employing reenlistment information transferred from analyses performed in RAP or from user input. Throughout YOS, default historical values are provided as parameters for the aging process, as well as the option to input values. Various analytical tables are available through monitor displays or hard copies, as well as automatic storage of parameters for future reference. Like RAP, YOS can perform analysis on all three categories of enlistment by AFS. RAP and YOS may be used independently or interactively.

The theoretical foundations for the development of the underlying AFRAP econometric model can be found in Saving, Stone, Looper, and Taylor (1985). Appendix A of this report provides a summary of the model.

II. REENLISTMENT ANALYSIS PACKAGE (RAP)

The Reenlistment Analysis Package (RAP) is designed to facilitate a user/machine information flow and analysis as indicated in Figure 1. The number in the corner of each rectangle corresponds to the number assigned to that screen in this manual. Movement within RAP can be forward by pressing (TAB) or backward by pressing (ESC). Pressing (TAB) stores all values which have been input by the user for each menu. If (ESC) is pressed prior to the completion of data input for a menu, only those values input by pressing (RETURN) after entry will be saved for future use. Pressing (ESC) after the final screen (Screen 4) will return the user to Screen 3, transferring the selective reenlistment bonus (SRB) multiple and reenlistment rate information generated by Screen 4. Pressing (ALT-Q) at any time in the sequence of screens will return the user to Screen 1 and, thus, provide the option to enter YOS, return to RAP, or exit. A help screen is available for each menu and can be displayed by pressing (ALT-H) at any time during the use or viewing of a menu. The options available for each menu are provided at the bottom of the screen. The software is programmed to accept only prescribed responses and will re-prompt the user for an input if the user-provided response fails to meet the expected response. Either upper- or lowercase is accepted. Following is a screen-by-screen explanation of RAP.

Reenlistment Analysis Package (RAP)

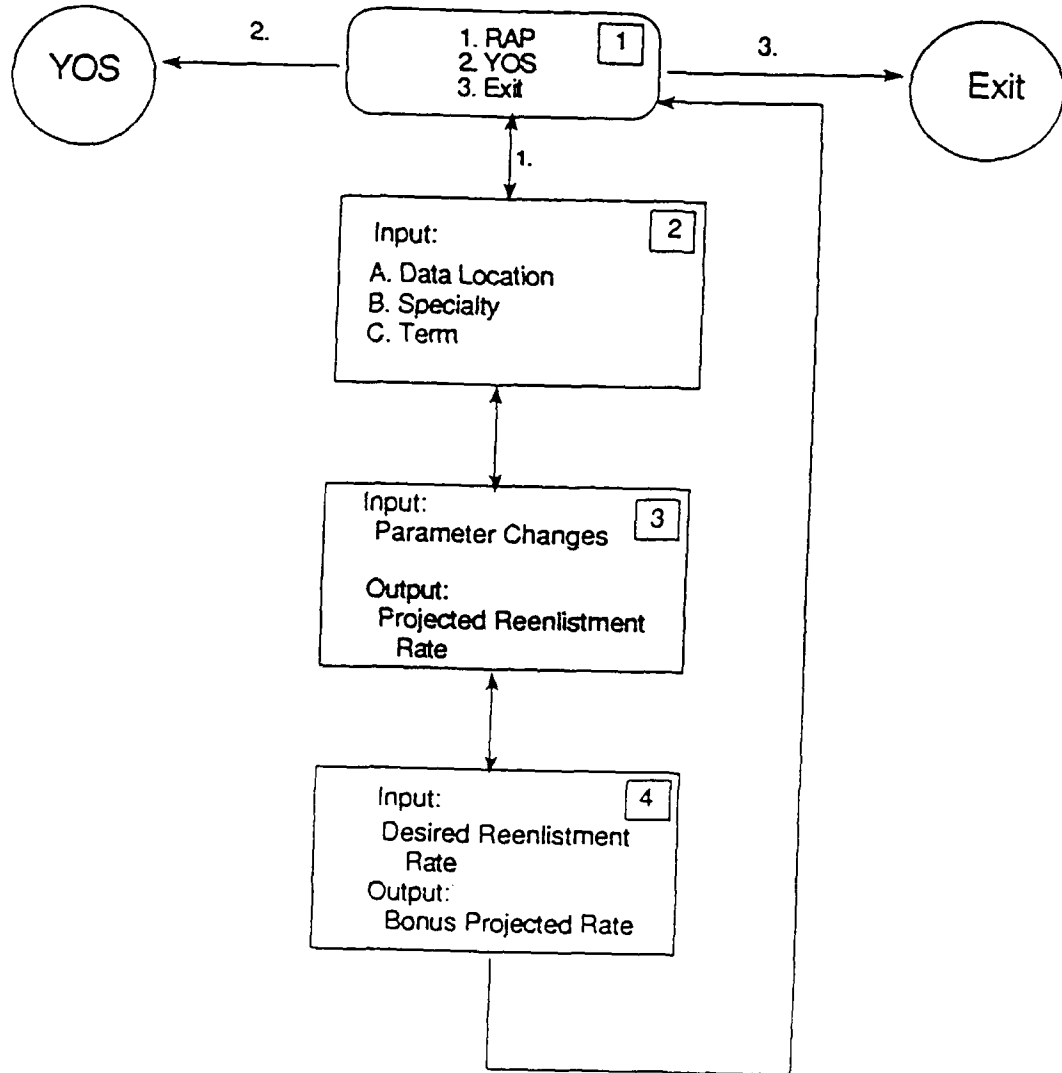

Figure 1. Reenlistment Analysis Package (RAP).

Screen 1

Screen 1 (Figure 2), which is the starting point for all analyses, provides the user with the choice to enter the Reenlistment Analysis Package (RAP) or Year of Service (YOS) analysis package or to exit the program. Pressing (1) and (RETURN) allows the user to enter RAP. Pressing (2) and (RETURN) allows the user to enter YOS. Pressing (3) and (RETURN) allows the user to exit the program.

Example: In the example presented in Figure 2, the user wished to enter RAP in order to manipulate the reenlistment rate and variables in the equation, and therefore entered a "1" for RAP and then (RETURN), which brought up Screen 2.

Air Force Retention Analysis Package, Ver. 4.0

(1) Reenlistment Analysis Package (RAP):

(2) Year of Service (YOS) Package:

(3) Terminate Session:

Select option for current session. 1

ENTER APPROPRIATE CHARACTER OR NUMBER AS SHOWN ABOVE.
PRESS (TAB) TO USE DISPLAYED VALUES.
(ALT-H) FOR HELP, (ALT-Q) TO QUIT, (ESC) FOR PREVIOUS MENU

Figure 2. Screen 1.

Screen 2

Screen 2 (as shown in Figure 3) prompts the user for input information which will allow AFRAP to access data for the performance of reenlistment rate analyses by category of enlistment and AFS. The user-selected AFS and category of enlistment will be displayed at the top of each subsequent menu for user reference. The responses for prompts A through C will be retained in memory and transferred automatically to the YOS portion when the user opts to enter YOS. Regardless of the number of times in which the user returns to Screen 2, all user input responses will be retained as defaults unless the user exits the package.

- A. Enter the full name of the location of the input data (disk drive, hard disk partition, or path name; i.e., b: or b:\afsc\data, and press {RETURN}).
- B. Enter the Air Force Specialty Code (AFSC) for the career field (i.e., 272x0 for Air Traffic Controllers) followed by pressing {RETURN}. The list of possible career fields can be found in Appendix B.
- C. Enter the category of enlistment by pressing (F) for first term, (S) for second term, (C) for career, followed by pressing {RETURN}.

Enter each response by pressing the appropriate letter or alphanumeric code and then press {RETURN}. All selected responses will be displayed on a single line below the prompts. In this example, the row displaying A.a, B.272x0, and C. f is the response row. When all desired responses are displayed on the response row, press {TAB} to continue.

Example: In the example provided in Figure 3, the user may wish to analyze reenlistment behavior on all three categories for Air Traffic Controllers, but can do only one category at a time. The relevant data for this scenario were on a floppy disk in drive A, shown by the "a" entered on prompt A, which requests the location of the data. For the next prompt, the user entered the four-digit AFSC for the desired specialty, which in this case was 272x0. For prompt C, the user entered "f" to begin the analysis with the first term. After the responses were entered, the user pressed {TAB}, bringing up Screen 3. To analyze the second term and career, the user would provide the same responses to prompts A and B in Figure 3, but replace "f" in prompt C with "s" for second term or "c" for career.

Air Force Retention Analysis Package, Ver. 4.0

A. Enter disk drive or path name for input data (i.e. A or A:\AFSC\DATA).

B. Enter specialty (i.e. 272x0).

C. Enter reenlistment category (F)irst, (S)econd, or (C)areer.

A. a B. 272x0 C. f

ENTER APPROPRIATE CHARACTER OR NUMBER AS SHOWN ABOVE. PRESS {TAB}
TO USE DISPLAYED VALUES. {ALT-H} FOR HELP, {ALT-Q} TO QUIT, {ESC} FOR
PREVIOUS MENU

Figure 3. Screen 2.

Screen 3

Screen 3 (Figure 4) provides the user with the opportunity to change any of the values assigned to the explanatory variables in the estimation equation in order to calculate the projected reenlistment rate. Appendix A provides a detailed discussion of the explanatory variables. The variables are defined as follows:

- ACED** - Proportion of personnel with a high school diploma or higher
- RACE** - Proportion of non-Caucasians
- AFQT** - Proportion of personnel in mental categories I and II based on the Armed Forces Qualification Test composite from the Armed Services Vocational Aptitude Battery
- DEPT** - Proportion of personnel with at least two or more dependents
- MARST** - Proportion of personnel with a marital status of single
- SEX** - Proportion of females
- BONUS** - Selective Reenlistment Bonus
- CWAGE** - Relevant civilian wage
- REMP** - Employment rate
- BASIC** - Basic pay
- BAS** - Basic allowance for subsistence
- BAQ** - Basic allowance for quarters

ACED, RACE, AFQT, DEPT, MARST, and SEX are each expressed as a proportion of the AFS with the specified attribute and, thus, always has a value between 0 and 1.0.

The beginning projected rate is the projected reenlistment rate using the most recently available sample means of the explanatory variables in the econometric model. These data will appear on the screen when RAP is initially entered for any particular AFS. (Appendix C provides a summary of the routine used to estimate the reenlistment rate from the estimated reenlistment equations.) For each variable the user selects to change, the sample mean for the latest fiscal year and a minimum and maximum value are displayed as guidelines for determining the value to assign to the variable. The minimum and maximum values are calculated assuming that the variation in the value of the variable is normally distributed about the mean, and the minimum/maximum values denote two standard deviations above/below the sample mean.

One or more values may be changed, and a new projected reenlistment rate will be calculated for each change in a variable value. To change a value, press

Air Force Retention Analysis Package, Ver. 4.0
First Term - 272x0

01. ACED :	.945	07. BONUS :	2.000
02. RACE :	.159	08. CWAGE :	1586.776
03. AFQT :	.548	09. REMP :	.885
04. DEPT :	.199	10. BASIC :	952.200
05. MARST :	.483	11. BAS :	158.470
06. SEX :	.188	12. BAQ :	183.000

Select value to be changed (ex: 02):

Projected rate: .6053

MEAN: MIN: MAX:

Push keys of highlighted characters to select value to change. (Tab) key proceeds to bonus estimator. (Esc) key returns to last menu. (*) retrieves original mean values. (Return) leaves value as displayed. (Alt-Q) will return to main menu. (Alt-H) will provide help screen.

Figure 4. Screen 3.

the number corresponding to the explanatory variable (e.g., 02 for RACE) and press (RETURN). This will move the cursor to the value for that variable. Input the desired value and press (RETURN). Press (*) and (RETURN) at any time to retrieve the original values.

The selection of BASIC, BAS, BAQ, and CWAGE will result in a two-step response sequence. The first prompt allows the user to choose the magnitude of the change in nominal dollars or percentage. For a nominal dollar change, enter the desired magnitude of the change and {N}; e.g., 10n for a 10 dollar increase in the value of the explanatory variable. For a percentage change, enter the desired percentage change and {P}; e.g., -5p for a 5% decrease in the value of the explanatory variable. Positive and negative numbers are accepted by the program. The second prompt allows the user to choose the rate of inflation (positive, negative, or zero) by which the desired changes will be transformed into real dollar changes. This is a necessary step before estimating the reenlistment rate. If the user selected BASIC, BAS, or BAQ, a third prompt will appear inquiring whether the user desires the same nominal or percentage change to be made to the other two variables. The response of (Y) for "Yes" will change BASIC, BAS, and BAQ, whereas (N) for "No" will change only the originally selected variable.

If the user wishes to switch into analysis in the YOS portion of the software, then the most recently displayed projected reenlistment rate will be transferred to YOS as the present rates in Screen 5, along with any other user-generated projected reenlistment rates in other categories of enlistment for the particular AFS.

Example: In Figure 4, Screen 3 appears with historical values for the most recently available fiscal year already assigned to the explanatory variables. The values in Figure 4 correspond to first-term Air Traffic Controllers, as was designated in the previous screen, Figure 3, and is also displayed at the top of the screen for reference. A projected reenlistment rate using the given values is displayed. Here, the projected rate is .6053; that is, the probability that a first-term airman in AFS 272x0 will reenlist given the above initial set of explanatory variable mean values is .6053; i.e., 60.53% of the first-termers in AFS 272x0 under the given conditions are projected to reenlist. When a variable is selected for analysis, the mean, minimum, and maximum values associated with the variable are provided to guide the analyst in the determination of a value.

Screen 4

Screen 4 (shown in Figure 5) provides an opportunity to set a desired reenlistment rate for the AFS and the category of enlistment under analysis. The selected reenlistment rate must be between 0.0 and 1.0. Given the assigned values for all variables other than BONUS from the previous menu, the program will calculate the SRB multiple necessary to attain the desired reenlistment rate. The value of the SRB multiple will not be allowed to exceed 6.0 and will be accompanied by the corresponding projected reenlistment rate. The projected rate accounts for cases in which the desired rate is beyond that attainable with an allowable SRB multiple. In such a case, the SRB multiple will be assigned the maximum value of 6.0, and a projected reenlistment rate will be estimated on the basis of an SRB multiple of 6.0. Instances may also arise in which the desired reenlistment rate is at a level below that attainable with a positive SRB, in which case the value of 0.0 will be assigned to the SRB multiple and a projected reenlistment rate will be estimated on the basis of an SRB multiple of 0.0.

The user may continue to input desired reenlistment rates, resulting in corresponding SRB multiples without moving to another screen. When the user moves to the previous screen by pressing (ESC), the desired (or default in case of SRB multiples of 0.0 or 6.0) reenlistment rate and the calculated SRB will also be transferred. Pressing (ALT-Q) allows the user to leave the RAP portion of the software package and return to Screen 1. (ALT-Q) and (ESC) are the only means available for leaving Screen 4.

Example: In the example presented in Figure 5, the user wished to observe what BONUS must be in order to attain a reenlistment rate of .6500; so, the user entered ".6500" at the prompt and pressed (RETURN). Given the variable values in the previous screen, a reenlistment rate of .6500 would require a bonus multiple of 5.240.

Air Force Retention Analysis Package, Ver. 4.0
First Term - 272x0

Select desired reenlistment rate(ex: .23): .6500

Bonus = 5.240

Reenlistment rate = .6500

{ALT-H} FOR HELP, {ALT-Q} TO QUIT, {ESC} FOR PREVIOUS MENU

Figure 5. Screen 4.

III. YEAR OF SERVICE (YOS) ANALYSIS

The YOS analysis portion of this software package has more user-controlled options than RAP. Figure 6 shows a general flow diagram of YOS. The number in the corner of each rectangle is the corresponding number of that screen in this manual.

At any point throughout the YOS, various options may be chosen to control the sequence of the screens. As in RAP, pressing (ALT-Q) will return the user to Screen 1 and provide the option to enter RAP, return to YOS, or exit the program. Pressing (ESC) will display the previous menu. However, if (ESC) is pressed prior to completion of data input for a menu, only those values input by pressing (RETURN) after entry will be saved for future use. Pressing (TAB) results in storage of all input responses into memory and the movement of the analysis to the next screen. Help screens are available for all screens which have the option for user input. Pressing (ALT-H) will display the help screen for the menu in which the user is presently working. As in RAP, all the available options are displayed at the bottom of each screen. The following narrative is a screen-by-screen explanation of YOS.

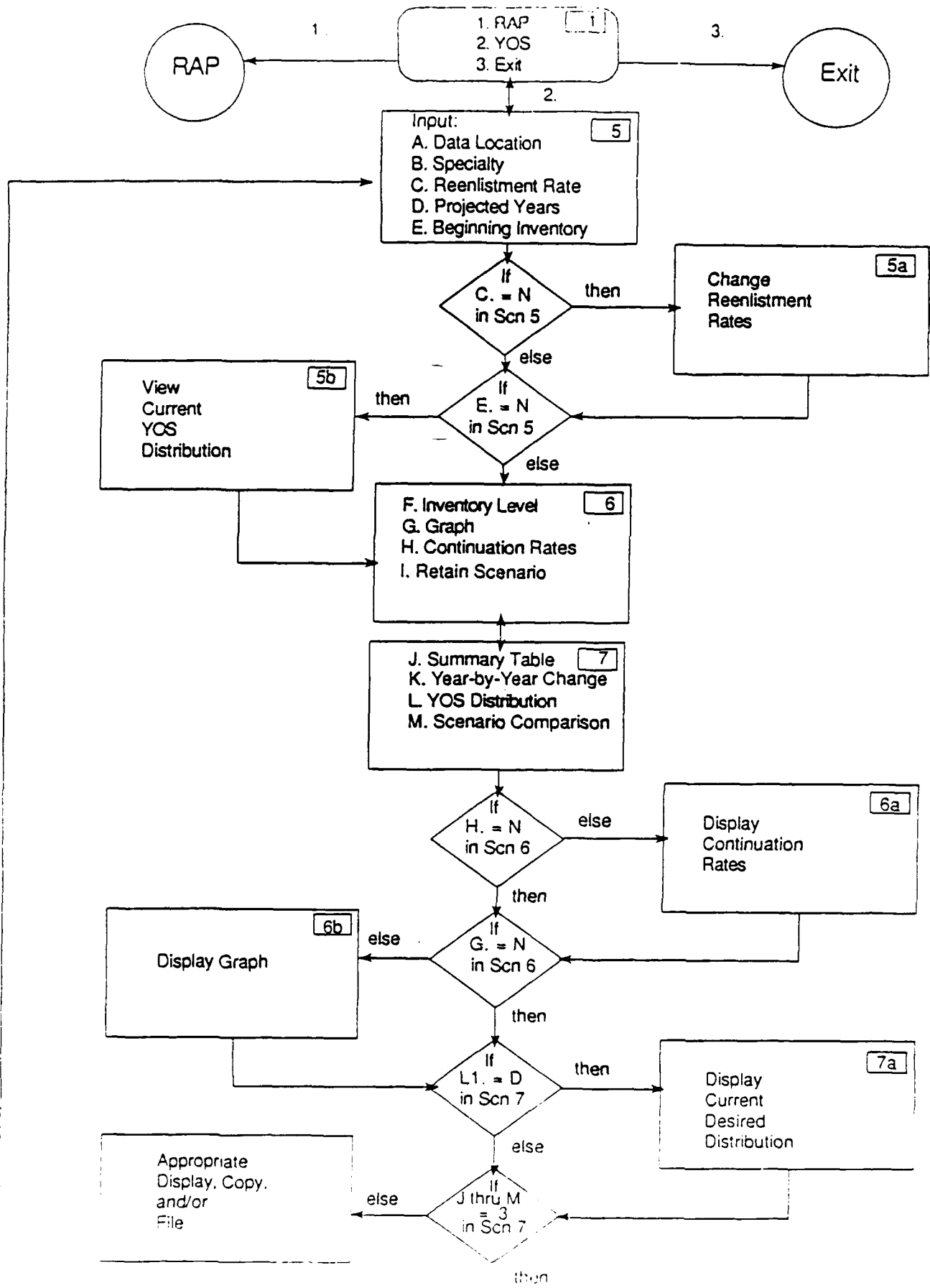

Figure 6. Year of Service (YOS) Analysis.

Screen 5

To begin analysis in YOS, the user must first input information pertaining to the data to be analyzed, similar to Screen 2 in RAP, in addition to information which is specific to the YOS analysis. If the user performed work in RAP before entering YOS, the location of the data and the AFS from Screen 2 of RAP will be transferred as defaults for prompts A and B, subject to user change. Also, the present reenlistment rates displayed in prompt C will reflect the work performed in RAP, provided the AFSC is not changed in prompt B.

- A. Enter the location of the input data (disk drive, hard disk partition, or path name); i.e., b or b:\afsc\data, unless previously entered in RAP. Then press (RETURN).
- B. Enter the AFSC (i.e., 272x0 for Air Force Air Traffic Controllers), followed by pressing (RETURN).
- C. Select the reenlistment rates which are to be used in the analysis. As shown in Screen 5 (Figure 7), (P)resent represents the rates presently being employed in the analysis or transferred from RAP. (L)ast rates are those used in a previous analysis and saved. (H)istorical represents the rates from fiscal year 1986. (N)ew provides the user with the option to input his/her own set of reenlistment rates. Selection of the (N)ew option will result in an interim screen (Screen 5a) in which the user may input the new reenlistment rates.
- D. Select the number of years to be projected beyond the base year; for example, responding with a 3 will age the AFS's experience inventory by 3 years.
- E. Select the years of service distribution to be used as the base. The user may choose a (H)istorical distribution based on the most recently available inventory, a (C)omposite distribution which the user develops from the historical distribution and inputs and/or modifies manually, or a (N)ew view (i.e., the current distribution being employed for the analysis). Both the (C) and (N) options will result in a table similar to Screen 5b in Figure 9. The (C)omposite will allow the user to view the historical inventory with the option to change it. The choice to view the current setting (N) will bring up the most recent distribution--whether historical or changed previously through (C) or (N)--with the option to input changes. Any changes made in the (N) option will be saved if the user enters RAP and returns to YOS.

Pressing (RETURN) after entering each response saves the response. Pressing (TAB) allows the user to proceed to the next screen.

Example: In the example provided in Figure 7, the present and historical rates displayed were transferred directly from the sequence performed in the previous examples in RAP (Figures 3 through 5). The historical rates displayed each time are the most recently available fiscal year reenlistment rates for AFS 272x0. The

Air Force Retention Analysis Package, Ver. 4.0

- A. Enter disk drive or path name for input data (i.e. A or A:\AFSC\DATA).
- B. Enter specialty (i.e. 272x0)
- C. Set reenlistment rates:

	(P)resent	(L)ast	(H)istorical	(N)ew
First Term	.6500	.7268	.6183	
Second Term	.7223	.5608	.7310	
Career	.8945	.9275	.9444	

- D. Set number of projection years:
(10) Enter number from 1 to 10 years
- E. Set Years of Service (YOS) distribution to be used:
(H)istorical
(C)omposite of historical and desired data
(N) view current setting

A. a B. 272x0 C. p D. 1 E. h

ENTER APPROPRIATE CHARACTER OR NUMBER AS SHOWN ABOVE
PRESS (TAB) TO USE DISPLAYED VALUES.
(ALT-H) FOR HELP, (ALT-Q) TO QUIT, (ESC) FOR PREVIOUS MENU

Figure 7. Screen 5.

present rates are the new projected rates calculated in RAP. The last rates were generated in a previous analysis of 272x0 and were saved for future use. At Screen 5, basic information pertaining to the data to be analyzed must be entered, and (RETURN) must be pressed after each response. Here, the data for prompts A and B were also automatically transferred from RAP. Since the location of the data and the AFSC were the same as in RAP, the user pressed (RETURN) until prompt C appeared. Here, the user decided to use the reenlistment rates just created in RAP for the YOS analysis, and entered "p" at prompt C, indicating to use the present rates. For prompt D, the user entered "1" for the number of projected years, to analyze reenlistment behavior for 1 year beyond the base year. The user entered "h" for prompt E, indicating to use the historical YOS distribution, and then pressed (TAB) which brought up Screen 6.

Screen 5a

Screen 5a (Figure 8) will appear if the user responds (N)ew to prompt C in Screen 5, thus indicating a desire to input new reenlistment rates.

- C. The user may choose to use the (P)resent, (L)ast, (H)istorical, or (N)ew rates. Present rates are those presently being employed in the analysis, last rates are those used in a previous analysis and saved, and historical rates refer to the most recently available fiscal year reenlistment rates. If the (N)ew option is entered, reenlistment rates must be entered for first term, second term, and career.
 - C1. If (N)ew rates are desired, the user provides the rate for First Term.
 - C2. If (N)ew rates are desired, the user provides the rate for Second Term.
 - C3. If (N)ew rates are desired, the user provides the rate for Career.
 - C4. The user may save the selected rates, whether (P)resent, (N)ew, or (H)istorical. The saved reenlistment rates will then be found as values under the heading of (L)ast in the next scenario.

Pressing (RETURN) after each response saves the response. Pressing (TAB) allows the user to continue to the next screen.

Example: In the example provided in Figure 8, the user has three sets of reenlistment rates from which to choose (present, last and historical) but has elected to input new reenlistment rates into the analysis as indicated by the response "n" to prompt C. The user proceeded to provide .6500 for first term, .7900 for second term, and .9600 for career. These rates will be used as the basis of the remaining analysis but the user has opted to not save these rates for future analysis as indicated by the response of "n" for prompt C4. If the user had responded with "y" for prompt C4, then the user-provided reenlistment rates would have overwritten the (L)ast reenlistment rates.

Air Force Retention Analysis Package, Ver. 4.0

Reenlistment rates are set as follows for: 272x0

	{P}resent	{L}ast	{H}istorical	{N}ew
First Term	.6500	.7268	.6183	C1.
Second Term	.7223	.5608	.7310	C2.
Career	.8945	.9275	.9444	C3.

C. Rates selected are: (P)resent, (L)ast, or (N)ew
C4. Save changed reenlistment rates: (Y)es or (N)o

C. n C1. .6500 C2. .7900 C3. .9600 C4. n

ENTER APPROPRIATE CHARACTER OR NUMBER AS SHOWN ABOVE.
PRESS (TAB) TO USE DISPLAYED VALUES.
(ALT-H) FOR HELP, (ALT-Q) TO QUIT, (ESC) FOR PREVIOUS MENU

Figure 8. Screen 5a.

Screen 5b

Screen 5b (Figure 9) provides the most recently available personnel inventory for the AFS by length of service from year 0 through year 33. This screen will appear if the user selects (C) or (N) or prompt E on Screen 5 to view the composite distribution or the current setting, respectively. To use the currently displayed values, press (TAB).

The inventory counts may be changed either sequentially or independently. To change the values sequentially, beginning with year 0, press (S). Enter the desired value and press (RETURN). The cursor will automatically move to the next year.

To correct a change or to change only selected years, enter the number of the year to be changed (e.g., enter 27 to change the value for year 27) and then (RETURN). Once the cursor moves to the selected year, input the desired value and press (RETURN). This process may be repeated for as many years as desired.

Example: In the example provided in Figure 9, the most recent personnel inventory for AFS 272x0 is provided. The user can alter any one or more of the year of service inventory levels before proceeding to the next screen, as well as maintain the inventory which is provided.

**Air Force Retention Analysis Package, Ver. 4.0
Personnel Inventory by Length of Service**

YEAR 0 : 448	YEAR 17 : 158
YEAR 1 : 476	YEAR 18 : 136
YEAR 2 : 364	YEAR 19 : 123
YEAR 3 : 359	YEAR 20 : 115
YEAR 4 : 491	YEAR 21 : 54
YEAR 5 : 500	YEAR 22 : 37
YEAR 6 : 414	YEAR 23 : 30
YEAR 7 : 299	YEAR 24 : 22
YEAR 8 : 303	YEAR 25 : 32
YEAR 9 : 267	YEAR 26 : 7
YEAR 10 : 244	YEAR 27 : 2
YEAR 11 : 229	YEAR 28 : 6
YEAR 12 : 209	YEAR 29 : 5
YEAR 13 : 162	YEAR 30 : 0
YEAR 14 : 122	YEAR 31 : 0
YEAR 15 : 109	YEAR 32 : 0
YEAR 16 : 157	YEAR 33 : 0

Press (S) for sequential or select year to be changed. {ex. 3}

{TAB} key uses displayed values.

{ALT-H} FOR HELP, {ALT-Q} TO QUIT, {ESC} FOR PREVIOUS MENU

Figure 9. Screen 5b.

Screen 6

Screen 6 (Figure 10) provides the user with options to determine the change in total inventory levels for all projected years, the type of graph on which the aging of the personnel inventory will be displayed, and the continuation rates to be employed in the aging process, as well as the ability to save the present aging scenario for comparisons with other aging scenarios.

- F. The user may maintain or alter the manning level of the career field. The (M)aintain option will result in no changes in the level of inventory. The (C)hange option will change the previous year's level each year by the selected amount. For example, a 10% change for a 5-year projection means that the inventory for the AFS will increase 10% each of the 5 years, resulting in an overall increase of 61.05% in the total force level (the product of 5 of 10% compounded increases). The (G)oal option is a once-and-for-all change in the inventory level; e.g., a 10% goal for a 5-year projection means the original inventory will increase by 10% the first projected year and remain at that level for the remaining 4 years.
- F1. and F2. When using the (C)hange option, enter the value of change with (N) for a magnitude change (e.g., 10N will increase the inventory level by 10 persons) and (P) for a percentage change (e.g., -5P will decrease the inventory level by 5%). Positive or negative values are accepted by the software package. However, when using the (G)oal option, enter the value with (N) to replace the current inventory level with the entered value (e.g., 100N will replace the current inventory level with 100) and with (P) to change the current inventory level by a percentage (e.g., -5p will decrease the current inventory level by 5%). For the (C)hange option these changes in the inventory will take effect during each of the projected years. The response to the F2 prompt sets the level of prior-service accessions allowed for each of the projected years. The determination of the experience distribution of prior-service accessions is discussed in Appendix D. The default for F2 is 0P.
- G. The user may select a (L)ine graph which compares all projected years with the base year or a (B)ar graph which compares the base year with the final projected year. The (N)one response does not provide the graph. (See Appendix E for an example.)
- G1. Different scale factors are available for the vertical axes on the graphs. The default scale factor will automatically ensure that the entire graph will appear on the screen, but the user may also select from vertical axes displaying up to 50%, 30%, or 20% (2.0, 3.0, or 5.0, respectively) of the total range of the percentages. This will expand or contract the graphical picture of the force.
- H. This prompt provides the user with the option to change the continuation rates for each of the length of service cohorts. The continuation rate is defined as the number of individuals who progress from one of the 33 year of service cohorts to the next cohort divided by the number of individuals who were in the original year of service cohort. The (Yes)

Air Force Retention Analysis Package, Ver. 4.0

F. Set strength level of specialty: (M)aintain, (C)hange, or (G)oal
Current strength level = 5880

F1. Change or Goal the strength level by:
{__}N)umber or {__}P)ercent (i.e. 100N or 10P)

F2. Select prior service accessions by:
{__}N)umber or {__}P)ercent (i.e. 100N or 10P)

G. Select type of graph: (L)ine, (B)ar, or (N)one

G1. Select scale factor:
(1) default scale factor (3) scale factor of 4.0
(2) scale factor of 2.0 (4) scale factor of 5.0

H. Change continuation rates: (N)o, (Y)es, or (R)ecall previous rates

I. Retain this scenario as base for re-enlistment comparison: (N)o (Y)es

F. m F1. F2. 0p G. l G1.1 H. n I. y

ENTER APPROPRIATE CHARACTER OR NUMBER AS SHOWN ABOVE.
PRESS (TAB) TO USE DISPLAYED VALUES.
{ALT-H} FOR HELP, {ALT-Q} TO QUIT, {ESC} FOR PREVIOUS MENU.

Figure 10. Screen 6.

response will result in a screen (Screen 6a) displaying the continuation rate for each of the 33 cohorts presently being employed, with the option to change them. The changed rates will then be saved on diskette or hard disk. However, to bring up these newly changed rates again, the user must press {R}ecall on this prompt. If the option to {R}ecall previous rates is selected, the user will view the resulting rates of the change made when the {Y}es option was chosen earlier. If no rates are stored, the present rates are brought to the screen. Thus, to change and save rates, press {Y}, and to view these changes, press {R}. The continuation rates will be displayed after the next menu (Screen 7). If {N}o is selected, no rates will be displayed.

- I. The scenario presently being employed may be retained for comparison with future inventory aging scenarios. A response of {Y}es will allow the user to retain this scenario for future comparison (See prompt M on Screen 7). The saved data will later appear as the "last" scenario. The default on this response is {N}o, which will not save the scenario.

Press {RETURN} after entering each response to input the response. Press {TAB} to continue to the next screen.

Example: In the example provided in Figure 10, the user wished to maintain the current strength level of 5880 for AFSC 272x0, and pressed "m" for prompt F. The cursor then automatically moved to prompt F2 which has a default change in prior-service accessions of 0%, for which the user opted. By entering "I" for prompt G and "I" for prompt G1, the user desired to have the results displayed on a line graph in the default scale. To use continuation rates generated by YOS (see Appendix F), the user entered "n" for prompt H. The user entered "y" for prompt I to save this scenario for comparison with a future scenario and then pressed {TAB} to proceed to Screen 7.

Screen 6a

Screen 6a (Figure 11) will appear if the user enters either (Y)es or (R)ecall to prompt H on Screen 6, opting to change current continuation rates or recall previous continuation rates. This screen lists, from year 0 to year 33, current continuation rates by length of service. To use the currently displayed values, press (TAB). However, the continuation rates may be changed either sequentially or independently. To change the values sequentially, beginning with year 0, press (S). Enter the desired value and press (RETURN). The cursor will automatically move to the next year.

Continuation rates are defined as the proportion of members of a year of service cohort (e.g., all enlisted personnel with 4 years of service) that continue into the next year of service cohort. For example, a continuation rate of 0.45 for year of service cohort 4 means that 45% of the enlisted personnel in their 4th year of service will continue into their 5th year of service. Variations in certain continuation rates tend to mirror changes in reenlistment rates and are implicit in the program. Since most reenlistment/separation decisions occur at policy-determined points along the enlisted career path (especially in the Air Force), the continuation rates between career decision points experience minimal variation over time. Separations which occur between career decision points are predominantly non-voluntary separations. The continuation rates used in the aging of the enlisted personnel inventory are determined from historical values in cases where the continuation rate exhibited minimal historical variation (i.e., was not at a career decision juncture). Continuation rates at career decision points are calculated as functions of the appropriate reenlistment rates which are either transferred from RAP or selected by the user. Thus, the variability in the reenlistment rates affect only certain year of service groups. For additional discussion of the conversion of reenlistment rates into continuation rates, see Appendix F.

To correct a change or to change only selected years, enter the number of the year to be changed (e.g., enter 27 to change the value for year 27) and then press (RETURN). Once the cursor moves to the selected year, input the desired value and press (RETURN). This process may be repeated for as many years as desired.

Example: In the example provided in Figure 11, the user has the option to change any of the 33 continuation rates or accept them as they appear. This screen displays the current continuation rates for AFS 272x0. For example, in year of service 4, the continuation rate is 0.794. This means that 79.4% of the beginning inventory in year of service 4 will continue to year of service 5.

Air Force Retention Analysis Package, Ver. 4.0
Current Continuation Rates by Length of Service

YEAR 0 :	.901	YEAR 17 :	.995
YEAR 1 :	.894	YEAR 18 :	.994
YEAR 2 :	.901	YEAR 19 :	.500
YEAR 3 :	.813	YEAR 20 :	.665
YEAR 4 :	.794	YEAR 21 :	.726
YEAR 5 :	.894	YEAR 22 :	.667
YEAR 6 :	.854	YEAR 23 :	.773
YEAR 7 :	.933	YEAR 24 :	.838
YEAR 8 :	.917	YEAR 25 :	.532
YEAR 9 :	.922	YEAR 26 :	.671
YEAR 10 :	.967	YEAR 27 :	.517
YEAR 11 :	.968	YEAR 28 :	.691
YEAR 12 :	.973	YEAR 29 :	.155
YEAR 13 :	.983	YEAR 30 :	.000
YEAR 14 :	.989	YEAR 31 :	.000
YEAR 15 :	.989	YEAR 32 :	.000
YEAR 16 :	.994	YEAR 33 :	.000

Press (S) for sequential or select year to be changed (ex: 3)

(TAB) key uses displayed values.

(ALT-H) FOR HELP, (ALT-Q) TO QUIT, (ESC) FOR PREVIOUS MENU

Figure 11. Screen 6a.

Screen 7

As shown in Figure 12, several table options are provided to assist in interpreting the results of the analyses. For each table (prompts J through M on Screen 7), the user has the option to display the table on the monitor, produce a hard copy of the table by submitting it to a printer, and/or generate a data file of the table in the same location as the data (Screen 2 or 5, prompt A). These options are listed at the top of the screen (values 1 through 8). A detailed explanation of the contents of each of the tables is presented in Appendix G with examples.

- J. The summary table provides a year-by-year summary of the projected accessions, prior-service accessions, losses, and personnel inventory level.
- K. The year-by-year projection table provides the projected year-by-year change in the YOS inventory distribution resulting from the aging of the beginning personnel inventory.
- L. The YOS distribution table provides a) a comparison between the YOS distribution for the base year versus the final projected year and b) a comparison of the YOS distribution of the base year with an intermediate projection year or a comparison of the YOS distribution of the final projected year with a desired YOS distribution provided by the user.
- L1. and L2. The {D}esired option will result. Screen 7a provides a current desired YOS distribution which the user may alter if desired. Instead of the desired YOS distribution, one of the other projected years may be used. The {P}redicted option will use, in addition to the final year, the year designated in M2 for comparison. Enter the number of the projected year, from 1 to 10, to be used in the comparison.
- M. The reenlistment comparison table compares, by category of enlistment, the current YOS table and accessions with the YOS and accessions of the previously saved scenario.

Press {RETURN} after entering each response to input the response. Press {TAB} to continue to the next screen.

Example: In the example provided in Figure 12, the user entered "1" for prompts J and K to have only screen displays of the summary table and the year-by-year change in YOS distribution table. No YOS distribution table or reenlistment comparison table was desired since the user entered a "3" for prompts M and L (the program automatically skipping prompts L1 and L2). Next, the user pressed {TAB} which, in this case, brought the line graph to the screen.

Air Force Retention Analysis Package, Ver. 4.0

Select one of the following options for each of the tables:

- | | |
|----------------------------------|-------------------------------|
| (1) Display, no copy, no file | (5) Display, no copy, file |
| (2) Display, copy, no file | (6) Display, copy, file |
| (3) No display, no copy, no file | (7) No display, no copy, file |
| (4) No display, copy, no file | (8) No display, copy, file |

J. Summary Table

K. Year by year change in YOS distribution table

L. Years of Service (YOS) distribution table

L1. Use for comparison in YOS distribution:
(P)redicted profile or (D)esired profile

L2. Use for comparison, projected year:
(03), enter number from 1 to 10 years

M. Reenlistment comparison table

J. 1 K. 1 L. 3 L1. L2. M. 3

ENTER APPROPRIATE CHARACTER OR NUMBER AS SHOWN ABOVE.
PRESS (TAB) TO USE DISPLAYED VALUES.
(ALT-H) FOR HELP, (ALT-Q) TO QUIT, (ESC) FOR PREVIOUS MENU

Figure 12. Screen 7.

Screen 7a

Screen 7a (Figure 13) will appear if the user selects the (D)esired response to prompt L1 on Screen 7 in Figure 12, opting to use a desired profile for the YOS distribution table. This screen lists, from year of service 0 to year 33, the most recently available inventory against which the last projected year of the length of service inventory will be compared. To use the currently displayed values, press (TAB).

The inventory counts may be changed either sequentially or independently. To change the values sequentially, beginning with year 0, press (S). Enter the desired value and press (RETURN). The cursor will automatically move to the next year.

To correct a change or to change only selected years, enter the number of the year to be changed (e.g., enter 27 to change the value for year 27) and then (RETURN). Once the cursor moves to the selected year, input the desired value and press (RETURN). This process may be repeated for as many years as desired.

Example: In the example presented in Figure 13, the user is provided the default desired inventory distribution which will always equal the (H)istorical distribution, until the user changes the desired inventory distribution through Screen 7a.

Air Force Retention Analysis Package, Ver. 4.0
Current Desired Distribution by Length of Service

YEAR 0 : 448	YEAR 17 : 158
YEAR 1 : 476	YEAR 18 : 136
YEAR 2 : 364	YEAR 19 : 123
YEAR 3 : 359	YEAR 20 : 115
YEAR 4 : 491	YEAR 21 : 54
YEAR 5 : 500	YEAR 22 : 37
YEAR 6 : 414	YEAR 23 : 30
YEAR 7 : 299	YEAR 24 : 22
YEAR 8 : 303	YEAR 25 : 32
YEAR 9 : 267	YEAR 26 : 7
YEAR 10 : 244	YEAR 27 : 2
YEAR 11 : 229	YEAR 28 : 6
YEAR 12 : 209	YEAR 29 : 5
YEAR 13 : 162	YEAR 30 : 0
YEAR 14 : 122	YEAR 31 : 0
YEAR 15 : 109	YEAR 32 : 0
YEAR 16 : 157	YEAR 33 : 0

Press (S) for sequential or select year to be changed (ex: 3):

{TAB} key uses displayed values.

{ALT-H} FOR HELP, {ALT-Q} TO QUIT, {ESC} FOR PREVIOUS MENU

Figure 13. Screen 7a.

Screen7b

This screen (Figure 14) will appear after the desired distribution table is displayed. The (N)o response will use the changed distributions for the present scenario, but will not save them for future use. The (Y)es response will write the newly entered distribution over the original desired distribution for use in the present scenario, as well as saving it for future scenarios.

Example: In the example provided in Figure 14, the user has opted not to save the changes which have been made to the desired inventory distribution by providing "n" as the response.

Air Force Retention Analysis Package, Ver. 4.0

Overwrite the original desired length of service distribution {Y/N}: n

Figure 14. Screen 7b.

IV. INTEGRATION OF RAP AND YOS

AFRAP is designed in such a manner that the Reenlistment Analysis Package (RAP) and Year of Service (YOS) Analysis may be executed independently or interactively (see Figure 15). The user may switch between the two parts of the software package by returning to Screen 1 and then opting for the other package.

There does exist some automatic transfer of information between RAP and YOS. The most recent reenlistment rate displayed in Screen 3 (RAP), without exiting the program, will appear as the "present" rate in Screen 5 (YOS). Also, for user convenience, if the user executes a scenario in YOS and then enters RAP, the location of the data and the AFSC used in YOS will be transferred to Screen 2 in RAP. The user always has the option to change the location of the data and the AFSC.

Integration of RAP and YOS

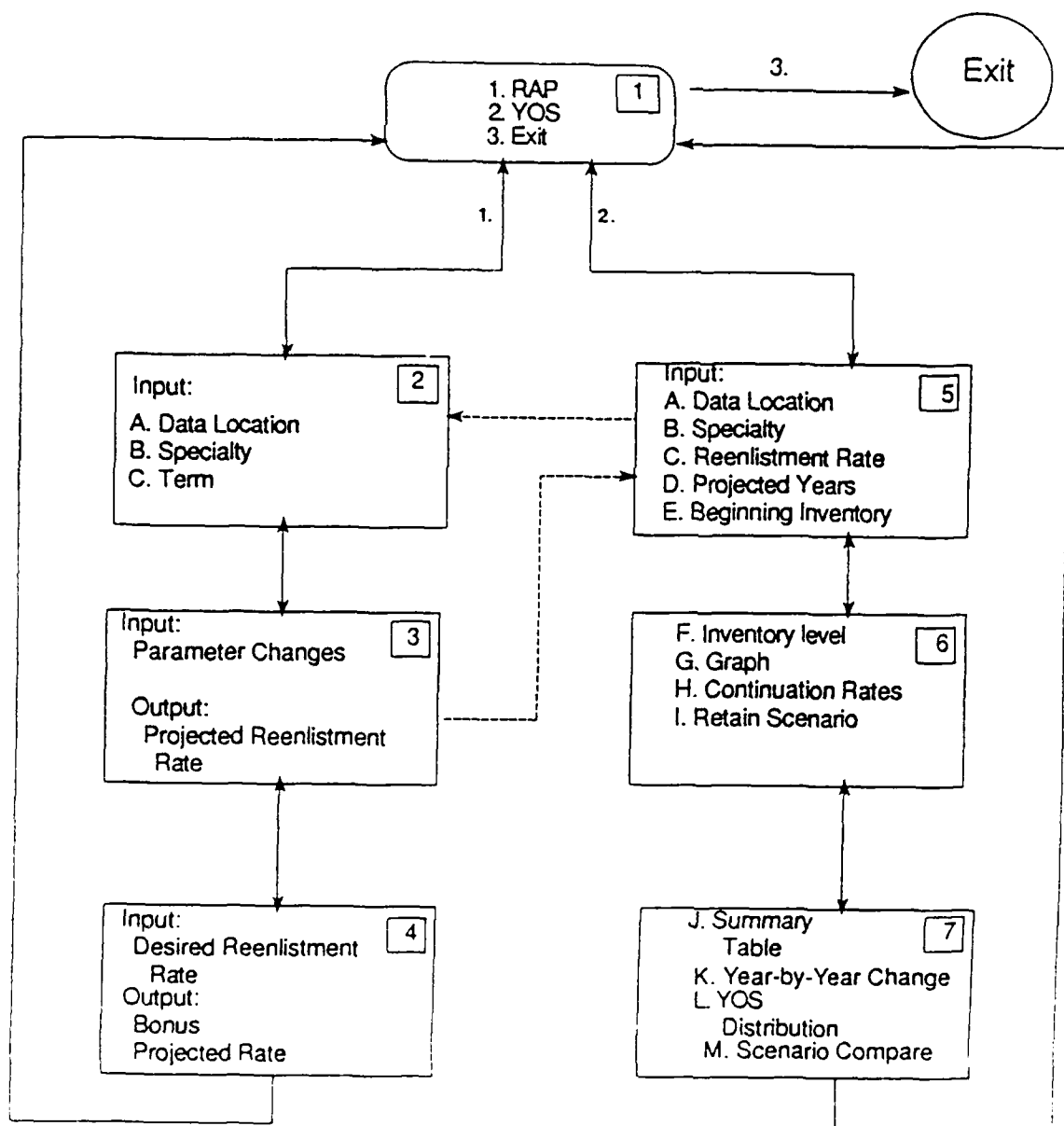

Figure 15. Integration of RAP and YOS.

REFERENCES

- Amemiya, T. (1981, December). Qualitative response models: A survey. Journal of Economic Literature, 19, (4).
- Pindyck, R.S., & Rubinfeld, D.L. (1981). Econometric models and economic forecasts. New York: McGraw-Hill.
- Saving, T.R., & Stone, B.M. (1983, September). Air Force prior service market analysis (Contract No. F49642-82-C054). Washington, DC.
- Saving, T.R., Stone, B.M., Looper, L.T., & Taylor, J.N. (1985, July). Retention of Air Force enlisted personnel: An empirical examination (AFHRL-TP-85-6, AD-A158 091). Brooks AFB, TX: Manpower and Personnel Division, Air Force Human Resources Laboratory.

APPENDIX A: A MODEL OF ENLISTED RETENTION

The military competes with private and public organizations for enlisted personnel in two distinct national labor markets: the entry level or unskilled market and the skilled market. To analyze Air Force accessions, the unskilled market is the relevant market. Conversely, in analyzing retention, the skilled labor market is the relevant market. Skilled Air Force personnel possess occupation-specific knowledge which must be considered in the modeling of the retention decision process. The approach employed in the following retention analysis utilizes a model of retention that considers both the occupational and individual characteristics, as well as policy and force management factors.

A Theoretical Model of Individual Retention

The number of enlisted personnel actually reenlisting is composed of two components: The number of reenlistment-eligible personnel leaving a given experience group and the probability that a randomly chosen individual leaving that given group will reenlist. Mathematically,

$$R_{i,j+1} = (P_{ij}) (S_{ij}) \quad (A-1)$$

where $R_{i,j+1}$ represents the number of enlisted personnel reenlisting into group $j+1$ that are in AFS i and group j ; P_{ij} represents the probability that the representative eligible-to-reenlist individual in AFS i , completing a tour of duty in group j , will reenlist and enter group $j+1$; and S_{ij} represents the number of eligible-to-reenlist departures from group j in AFS i per period. The probability of reenlistment, P_{ij} , depends on two sets of factors: The first set represents the individual's attitude toward a military career versus a civilian career, as affected by individual-specific factors; and the second set represents job-specific aspects, such as pay and duty assignment.

In order to model the reenlistment decision, a function which represents an individual's attitude to reenlist is needed. In many ways, such a function is similar to other functional relationships which can be modeled as binary choices made by individuals; e.g., whether to buy a new car or house. These problems can be represented and solved through the construction of an attitude function in the following way.

Assume that a variable Z can be defined for each individual, such that Z is a linear function of specific factors affecting each individual's attitude toward the military (e.g., age, marital status, race) and military-specific components (e.g., pay) so that

$$Z = a + xb \quad (A-2)$$

where x is a row vector of individual-specific and military-specific components, and b is a column vector of coefficients. Assume further that the higher the value of Z , the greater the likelihood that an individual will reenlist; i.e., the more positive is the individual's attitude toward reenlistment.

Assume that a critical value Z^* , for Z , is associated with each individual such that if the Z of that individual is greater than Z^* , the person reenlists, and if Z is less than Z^* , the person separates. Of course, not all individuals have the same attitude function; so, the critical value of Z , Z^* , will differ across individuals. Assume that the probability distribution (density function) across individuals of the critical values Z^* is $f(Z^*)$. The integral of the density function indicates the

proportion of individuals with critical values Z^* in any given range Z_1 to Z_2 . The probability, P , that a randomly chosen individual will reenlist given the component vector x is

$$P = \int_{-\infty}^Z f(Z^*) dZ^* = F(Z) = F(a + xb) \quad (A-3)$$

where $Z = a + xb$ is the individual's predicted Z value and $F(Z) = F(a+xb)$ is the cumulative distribution function associated with probability density function $f(Z^*)$.

The estimation of P for any given individual would be difficult because the continuous variable Z cannot be observed; that is, there is no information on the individual's attitude toward reenlisting. The only available information is whether that individual stayed in the service or separated, and the individual-specific and military-specific components of the vector x . Therefore, let R represent a binary variable which equals 1 if the individual reenlists and 0 otherwise. Since $F(Z)$ is the probability that a randomly chosen individual will reenlist given the component vector x , the probability that the representative individual separates, P_S , is given by

$$P_S = \Pr(R = 0) = 1 - F(Z). \quad (A-4)$$

The econometric model for estimating this binary decision is the probit model which assumes that Z is a normally distributed random variable (Amemiya, 1981; Pindyck & Rubinfeld, 1981). Thus, the probability that an individual will reenlist, given his or her vector of attributes, x can be deduced from the standard cumulative normal distribution, $N(a+xb)$. The value P can be interpreted as the probability that an individual will stay in the military, given the individual's vector of attributes x . The signs of the estimated coefficients will indicate the direction of change in the probability of staying; i.e., the qualitative relationships between reenlistment and one of the independent variables, such as military compensation. If the coefficient has a negative value, the independent variable is inversely related to reenlistment. Conversely, a positive coefficient implies a direct relationship between reenlistment and the independent variable.

Estimation Equation: Specification of the Retention Model

In order to estimate the parameters of the probit model, a maximum-likelihood estimation procedure is employed. To construct the likelihood function for a set of separations and reenlistments, it is assumed that each individual's decision is independent. If P is the probability of reenlistment and $(1 - P)$ is the probability of separation, then the probability of occurrence of a given set of decisions (e.g., separation, separation, reenlistment, reenlistment, reenlistment, separation) is the product of the probabilities of each decision; i.e.,

$$(1 - P)(1 - P)(P)(P)(P)(1 - P). \quad (A-5)$$

Since $P = N(Z)$, the cumulative normal evaluated at Z , and $(1 - P) = [1 - N(Z)]$, (A-5) can be written as

$$L^* = \prod_{k=1}^n N(Z_k)^{R_k} [1 - N(Z_k)]^{1 - R_k} \quad (A-6)$$

where L^* is the likelihood function, n is the number of individuals in the sample, and R_k is equal to 1 if the individual reenlists and to 0 if the individual separates. The Z_k values are equal to the estimates from the following equation estimated initially using ordinary least squares,

$$Z_k = a + b_1 ACED_k + b_2 RACE_k + b_3 AFQT_k + b_4 DEPT_k + b_5 MARST_k + b_6 SEX_k + b_7 BONUS_k + b_8 CWAGE_k + b_9 REMP_k + b_{10} RMC_k, \quad (A-7)$$

where

- ACED - 1 - high school diploma or beyond, excluding GED or certificates
0 - otherwise,
- RACE - 1 - non-Caucasians
0 - Caucasians,
- AFQT - 1 - mental categories I and II
0 - otherwise,
- DEPT - 1 - two or more dependents
0 - otherwise,
- MARST - 1 - single
0 - otherwise,
- SEX - 1 - females
0 - males,
- BONUS - the present discounted value (using a 10% personal discount rate) in real (deflated) 1967 dollars of the Selective Reenlistment Bonus,
- CWAGE - the present discounted value (using a 10% personal discount rate) in real (deflated) 1967 dollars of 4 years of civilian income,
- REMP - employment rate based on race, sex, and age,
- RMC - the present discounted value (using a 10% personal discount rate) in real (deflated) 1967 dollars of 4 years of regular military compensation which includes basic pay, basic allowance for quarters, basic allowance for subsistence, and the marginal tax advantage accruing from the nontaxable nature of BAQ and BAS. In addition, RMC accounts for promotion over the 4 years.

The maximum-likelihood technique then uses the estimated coefficients in (A-7) as a base and iterates until the likelihood of the given set of separations and reenlistments is maximized.

The variables used in equation (A-7) describe the military and civilian environment for each individual at the time of the reenlistment/separation decision. The first six explanatory variables are variables describing the characteristics or attributes of the individual. The monetary variables, BONUS, CWAGE, and RMC, are adjusted for inflation using the consumer price index. RMC is not displayed as an option for value change in RAP (Figure 4), but the primary components of RMC, basic pay, basic allowance for subsistence (BAS), basic allowance for quarters (BAQ), are provided with the calculation of RMC performed internal to the AFRAP model. REMP, the employment rate, describes the general economic environment confronting the individual at the time the decision is made.

Once the coefficients of equation (A-7) are estimated, a predicted value can be generated for Z_k . The predicted value of Z_k forms the upper limit in the cumulative normal distribution $N(Z_k)$ and is used to evaluate $F(Z_k) = N(Z_k)$, which is equal to P , the probability of reenlistment. The probability of reenlisting can be interpreted for each AFS as a reenlistment rate, defined as the ratio of the number of reenlistments to the number of eligible-to-reenlist individuals making a decision.

APPENDIX B: LIST OF AFSs IN AFRAP

AFSC	DESCRIPTION
111x0	Defensive Aerial Gunner
112x0	In-Flight Refueling Operator
113x0	Flight Engineer
114x0	Aircraft Loadmaster
115x0	Pararescue/Recovery Specialist
116x0	Airborne Communications Systems Operator
117x0	Airborne Warning Command and Control Specialist
118x0	Airborne Computer Systems Specialist
118x1	Airborne Command & Control Communications Equipment Specialist
118x2	Airborne Radar Systems Specialist
121x0	Survival Training Specialist
122x0	Aircrew Life Support Specialist
201x0	Intelligence Operations Specialist
201x1	Target Intelligence Specialist
202x0	Radio Communications Analysis Specialist
205x0	Electronic Intelligence Operations Specialist
206x0	Imagery Interpreter Specialist
207x1	Morse Systems Operator
207x2	Printer Systems Operator
208x1	Germanic Cryptologic Linguist Technician
208x2	Romance Cryptologic Linguist Technician
208x3	Slavic Cryptologic Linguist Technician
208x4	Far East Cryptologic Linguist Technician
208x5	Mid East Cryptologic Linguist Technician
209x0	Defensive C3CM Specialist
222x0	Geodetic Specialist
231x0	Visual Information Media Specialist
231x1	Graphics Specialist
231x2	Still Photographic Specialist
232x0	Visual Information Production-Documentation Specialist
233x0	Imagery Production Specialist
241x0	Safety Specialist
242x0	Disaster Preparedness Specialist
251x0	Weather Specialist
271x1	Airfield Management Specialist
271x2	Operations Resources Management Specialist
272x0	Air Traffic Control Operator
273x0	Combat Control Operator
274x0	Command & Control Specialist
275x0	Tactical Air Command & Control Specialist
276x0	Aerospace Control & Warning Systems Operator
277x0	Space Systems Operations Specialist
302x0	Weather Equipment Specialist
302x1	Airborne Meteorological/Atmospheric Research Equipment Specialist
303x1	Air Traffic Control Radar Specialist
303x2	Aircraft Control & Warning Radar Specialist
303x3	Automatic Tracking Radar Specialist
304x0	Wideband Communications Equipment Specialist

AFSC	DESCRIPTION
304x1	Navigation Aids Equipment Specialist
304x4	Ground Radio Communications Specialist
304x5	Television Equipment Specialist
304x6	Space Communications Systems Equipment Operator/Specialist
305x4	Electronic Computer and Switching Systems Specialist
306x0	Electronic Comm. & Cryptographic Equipment Systems Specialist
306x3	Telecommunications Systems Maintenance
309x0	Space Systems Equipment Maintenance Specialist
316x3	Instrumentation Specialist
321x0	Bomb-Navigation Systems Mechanic
321x1	Defensive Fire Control Systems Mechanic
321x2	Weapon Control Systems Mechanic
322x2	Avionic Sensor Systems Specialist
323x1	Offensive Avionics Systems Specialist
323x2	Aircraft Computer and Multiplexing Systems Specialist
323x3	Defensive Avionics Systems Specialist
324x0	Precision Measurement Equipment Laboratory Specialist
325x0	Automatic Flight Control Systems Specialist
325x1	Avionics Instrument Systems Specialist
326x0	Avionics Aerospace Ground Equipment Specialist
326x3	Integrated Avionics EW Equipment & Component Specialist
326x4	Integrated Avionics Computerized Test Sta & Component Specialist
326x5	Integrated Avionics Manual Test Sta & Component Specialist
326x6	Integrated Avionics Attack Control Systems Specialist
326x7	Integrated Avionics Instrument & Flight Control Systems Specialist
326x8	Integrated Avionics Comm, Nav & Penetration Aids Systems Specialist
328x0	Avionic Communications Specialist
328x1	Avionic Navigation Systems Specialist
328x2	Airborne Warning & Control Radar Specialist
328x3	Electronic Warfare Systems Specialist
328x4	Avionic Inertial & Radar Navigation Systems Specialist
328x5	Airborne Command Post Communications Equipment Specialist
341x2	Defensive Systems Trainer Specialist
341x4	Flight Simulator Specialist
341x6	Navigation/Tactics Training Devices Specialist
341x7	Missile Trainer Specialist
361x0	Cable & Antenna Systems Installation/Maintenance Specialist
361x1	Cable Splicing Installation & Maintenance Specialist
362x1	Telephone Central Office Switching Eqpt. Spec., Elec/Electro-Mech
362x3	Missile Control Communications Systems Specialist
362x4	Telephone Equipment Installation & Repair Specialist
391x0	Maintenance Systems Analysis Specialist
392x0	Maintenance Scheduling Specialist
404x0	Precision Imagery & Audiovisual Media Maintenance Specialist
404x1	Aerospace Photographic Systems Specialist
411x0	Missile Systems Maintenance Specialist
411x1	Missile Maintenance Specialist
411x2	Missile Facilities Specialist
411x3	Missile Pneudraulic Specialist
411x4	Missile Liquid Propellant Systems Maintenance Specialist
423x0	Aircraft Electrical Systems Specialist

AFSC	DESCRIPTION
423x1	Aircraft Environmental Systems Mechanic
423x2	Aircrew Egress Systems Mechanic
423x3	Aircraft Fuel Systems Mechanic
423x4	Aircraft Pneudraulic Systems Mechanic
423x5	Aerospace Ground Equipment Mechanic
426x2	Jet Engine Mechanic
426x3	Turboprop Propulsion Mechanic
427x0	Machinist
427x1	Corrosion Control Specialist
427x2	Non-Destructive Inspection Specialist
427x3	Fabrication & Parachute Specialist
427x4	Metals Processing Specialist
427x5	Airframe Repair Specialist
431x0	Helicopter Mechanic
431x1	Tactical Aircraft Maintenance Specialist
431x2	Airlift/Bombardment Aircraft Maintenance Specialist
431x3	Airlift Aircraft Maintenance Specialist
431x4	General Aircraft Maintenance Specialist
431x5	O-2 Aircraft Airframe
461x0	Munitions Systems Specialist
462x0	Aircraft Armament Systems Specialist
463x0	Nuclear Weapons Specialist
464x0	Explosive Ordnance Disposal Specialist
465x0	Munitions Operations Specialist
472x0	Base Vehicle Equipment Mechanic
472x1	Special Vehicle Mechanic
472x2	General Purpose Vehicle Mechanic
472x3	Vehicle Body Mechanic
472x4	Vehicle Maintenance Control & Analysis Specialist
491x1	Information Systems Operator
491x2	Information Systems Programming Specialist
492x1	Information Systems Radio Operations Spec
492x2	Information Systems Electromagnetic Spectrum Mgt Specialist
493x0	Information Systems Control Specialist
496x0	Information Systems Programs Management Specialist
542x0	Electrician
542x1	Electric Power Line Specialist
542x2	Electrical Power Production Specialist
545x0	Refrigeration and Air Conditioning Specialist
545x1	Liquid Fuel Systems Maintenance Specialist
545x2	Heating Systems Specialist
545x3	CE Control System Specialist
551x0	Pavements Maintenance Specialist
551x1	Construction Equipment Operator
552x0	Carpentry Specialist
552x1	Masonry Specialist
552x2	Metal Fabricating Specialist
552x5	Plumbing Specialist
553x0	Engineering Assistant Specialist
554x0	CE Resources Management Specialist
555x0	Production Control Specialist

AFSC	DESCRIPTION
566x0	Entomology Specialist
566x1	Environmental Support Specialist
571x0	Fire Protection Specialist
591x0	Seaman
591x1	Marine Engine Specialist
602x0	Passenger & Household Goods Specialist
602x1	Freight and Packaging Specialist
603x0	Vehicle Operator/Dispatcher
605x0	Air Passenger Specialist
605x1	Air Cargo Specialist
611x0	Services Specialist
612x0	Meatcutter
612x1	Subsistence Operations Specialist
622x0	Food Service Specialist
631x0	Fuel Specialist
645x0	Inventory Management Specialist
645x1	Materiel Facilities Specialist
645x2	Supply Systems Analysis Specialist
651x0	Contracting Specialist
661x0	Logistics Plans Specialist
672x1	Financial Management Specialist
672x2	Financial Services Specialist
673x0	Auditing Specialist
674x0	Cost Analysis Specialist
701x0	Chapel Management Specialist
702x0	Administration Specialist
703x0	Reprographic Specialist
705x0	Legal Services Specialist
732x0	Personnel Specialist
732x1	Personal Affairs Specialist
732x4	Career Advisory Specialist
733x1	Manpower Management Specialist
734x0	Social Actions Specialist
741x1	Fitness and Recreation Specialist
742x0	Open Mess Management Specialist
751x0	Education Specialist
751x2	Training Specialist
751x3	Instructional System Specialist
753x0	Combat Arms Training & Maintenance Specialist
753x1	Gunsmith Technician
791x0	Public Affairs Specialist
791x1	Radio & TV Broadcasting Specialist
792x2	Historian Specialist
811x0	Security Specialist
811x2	Law Enforcement Specialist
821x0	Special Investigations Specialist
871x0	Instrumentalist
872x0	Instrumentalist Technician
902x0	Medical Service Specialist
902x1	Cardiopulmonary Laboratory Specialist
902x2	Surgical Services Specialist

AFSC	DESCRIPTION
903x0	Radiologic Specialist
903x1	Nuclear Medicine Specialist
905x0	Pharmacy Specialist
906x0	Medical Administrative Specialist
907x0	Bioenvironmental Engineering Specialist
908x0	Environmental Medicine Specialist
911x0	Aerospace Physiology Specialist
912x5	Optometry Specialist
913x0	Physical Therapy Specialist
913x1	Occupational Therapy Specialist
914x0	Mental Health Clinic Specialist
914x1	Mental Health Unit Specialist
915x0	Medical Materiel Specialist
918x0	Biomedical Equipment Maintenance Specialist
919x0	Orthotic Specialist
924x0	Medical Laboratory Specialist
924x1	Histopathology Specialist
925x0	Cytotechnology Specialist
926x0	Diet Therapy Specialist
981x0	Dental Assistant Specialist
982x0	Dental Laboratory Specialist

APPENDIX C: MATHEMATICAL APPROXIMATION OF THE PROBIT ESTIMATION FUNCTION

The reenlistment equations discussed in Sections 1 and 2 of this paper used probit analysis for the estimation of the equations. The probit analysis is based on the cumulative normal probability function. The complexity of the cumulative normal probability function requires the use of a mathematical approximation to estimate a projected reenlistment rate. The following is the source code for the mathematical approximation used in AFRAP for a probit equation with n explanatory variables.

```
a1 = 0.31938153
a2 = -0.356563782
a3 = 1.781477937
a4 = -0.821255978
a5 = 1.330274429
a6 = 0.2316419
sum =  $\Sigma(\text{coef}_i * \text{value}_i), i = 1, n$ 
z = ABS(sum)
fx = 0.3989423 * EXP(-.05*z*z)
y = 1 / [1 + (a6 * z)]
px = fx * [(a1 * y) + (a2 * y2) + (a3 * y3) + (a4 * y4) + (a5 * y5)]
Projected Reenlistment Rate = 1 - px
```

Where, coef_i is the value of the i th coefficient, value_i is the value assigned to the i th variable, and z is the upper limit of the integral of the cumulative normal probability function. The projected reenlistment rate always falls between 0 and 1.

APPENDIX D: PRIOR-SERVICE ACCESSIONS

The number of prior-service accessions is determined by the user input (see Figure 10). The user has the option to select the number of prior-service recruits on prompt F2 or the proportion of the total accession pool to be comprised of prior-service recruits. Once the number of prior-service recruits is determined, the number which flows into each year of service inventory is determined by the following proportions:

<u>Year of Service</u>	<u>Proportion</u>
3	0.23
4	0.47
5	0.08
6	0.16
7	0.03
8	0.02
9	0.01

For example, 47% of the prior-service recruits will flow into the 4th year of service inventory for the particular AFS selected. These proportions represent the historical flow of prior-service recruits into the personnel inventories (Saving et al., 1983). All fractions are rounded to the nearest whole number when computing the number of prior-service accessions.

APPENDIX E: LENGTH OF SERVICE DISTRIBUTION GRAPH

AFRAP provides the user with the ability to view a graphical depiction (line or bar graph) of the length of service distribution which results from the analysis scenario contrived in Screens 5 and 6. Prompt G in Screen 6 allows the selection of a bar graph or a line graph, and Prompt G1 allows the user to determine the size of the graph. The example provided in Figure E-1 shows a line graph of the percentage of the total force by year of service for AFSC 272x0 during the base year and 2 projected years. Figure E-2 shows a bar graph of the percentage of the total force by year of service for AFSC 272x0 during the base year and the second projected year. The user can obtain a hard copy of such a figure by pressing (Shift) {PrtSc}.

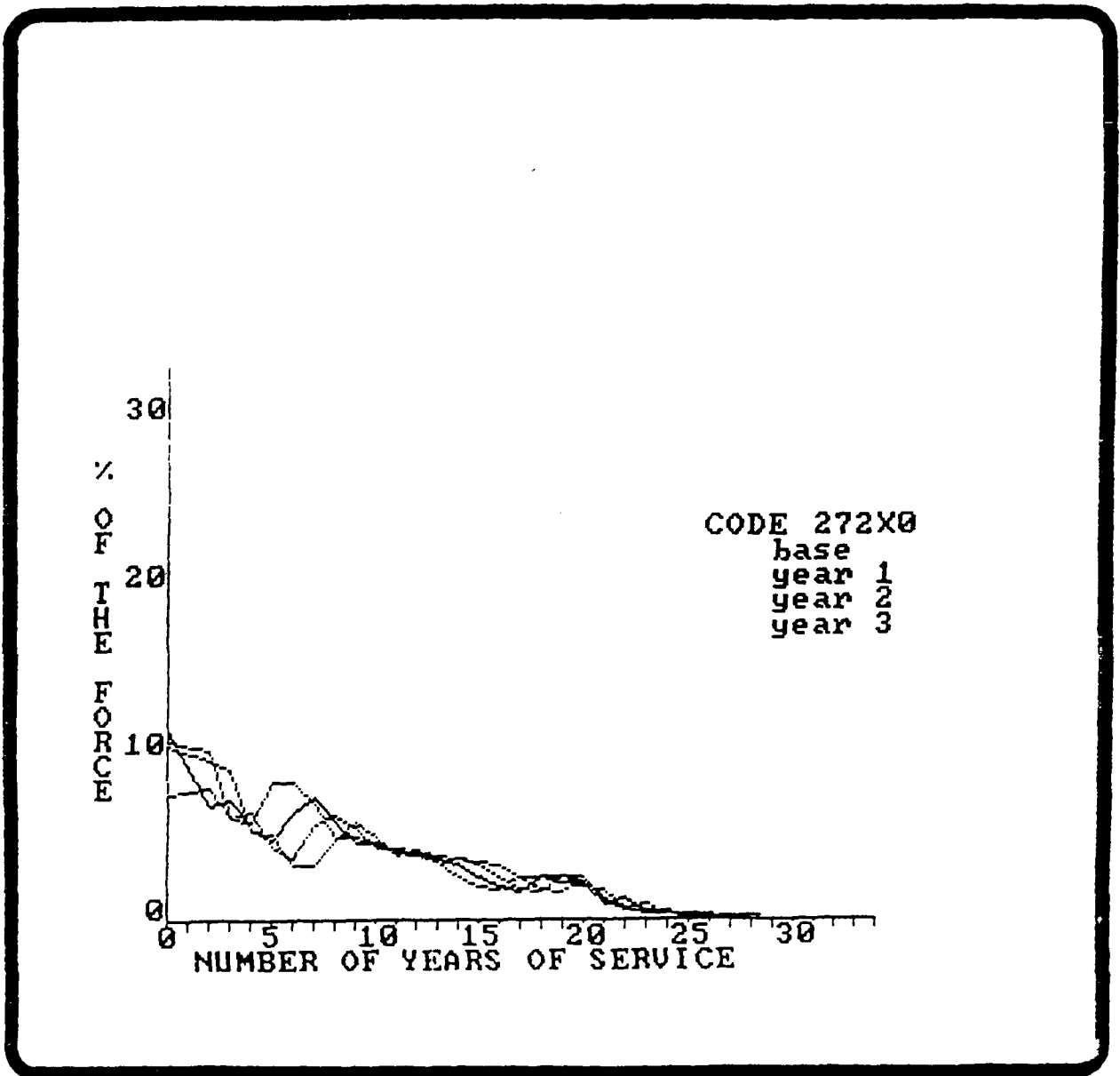

Figure E-1. Length of Service Distribution Line Graph.

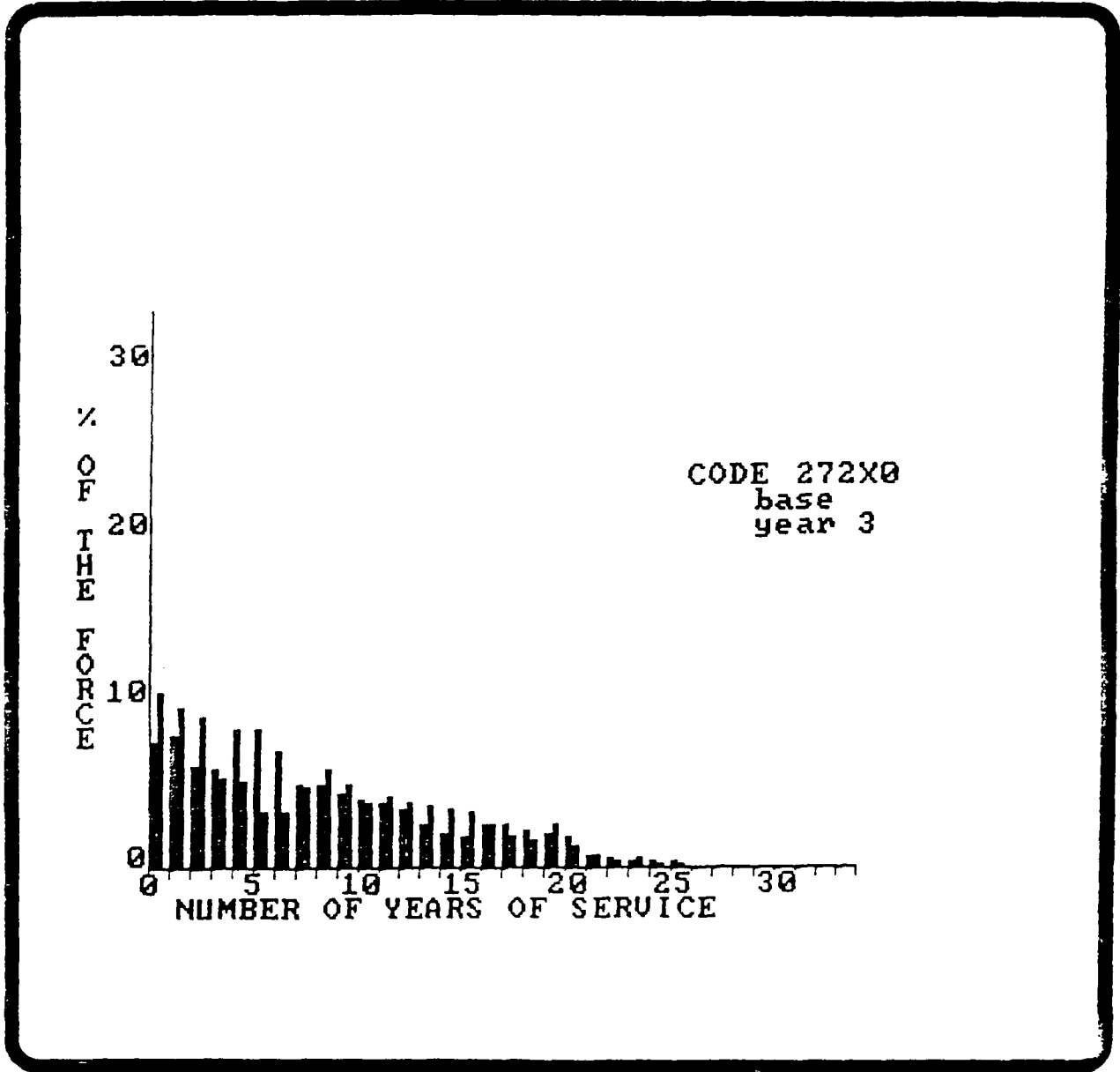

Figure E-2. Length of Service Distribution Bar Graph.

APPENDIX F: CALCULATION OF CONTINUATION RATES

AFRAP allows the user to change or modify the continuation rates to be employed in the aging process of the YOS portion (Figure 11, Screen 6a). Continuation rates are defined as the proportion of a YOS cohort (e.g., all enlisted personnel with at least 4 years of service) that continue into the next cohort. For example, a continuation rate of 0.45 for year of service cohort 4 means that 45% of the enlisted personnel in their 4th year of service will continue into their 5th year of service. Variation in certain continuation rates tends to mirror changes in reenlistment rates. Since most reenlistment/separation decisions occur at policy-determined points along the enlisted career path, the continuation rates between these points vary minimally over time. Separations which occur between career decision points are predominantly non-voluntary separations.

The continuation rates used in the aging of the enlisted personnel inventory are determined from historical values with minimal variation. That is, they are not at a career decision juncture. Continuation rates at career decision points are calculated as functions of the appropriate reenlistment rates which are either transferred from RAP or selected by the user. This transformation of reenlistment rates to continuation rates accounts for both the historical proportion of eligible to ineligible decision-makers and the historical level of decisions made at each decision point. In AFRAP, it is assumed that variability in the reenlistment rates affects only certain year of service groups.

For example, the first-term reenlistment rate affects only the continuation rates for year of service groups 3, 4, and 5. Groups 0, 1, and 2 employ historical continuation rates. Table F-1 provides an example of two different aging scenarios for AFS 272x0 (Air Traffic Controllers). The given reenlistment rates for scenario 2 are 0.10 higher than scenario 1 for the first and second terms and 0.05 higher for the career term. The continuation rates for years of service 3, 4, and 5 (first term), 7, 8, and 9 (second term), and 10, 11, and 12 (career term) increase from scenario 1 to scenario 2 as a result of the change in the reenlistment rates. The continuation rates for the remaining years of service do not change unless the user chooses to do so. The continuation rate increased by 0.036 for year of service 3, 0.040 for year of service 4, and 0.021 for year of service 5--all due to the increase in the first-term reenlistment rate of 0.10. The difference in the magnitude of the increase in the continuation rates from year of service 3 to 5 reflects the fact that the majority of first-term decisions occur as personnel transition from year 3 to 4 and 4 to 5.

The transformation of the reenlistment rates estimated in RAP or input by the user in Screen 5 relies upon three factors: the proportion of personnel in a year of service cohort who are decision-makers, the proportion of decision-makers in a year of service cohort who are eligible to reenlist, and the projected reenlistment rate for the relevant category of enlistment (e.g., first term, second term). The equation for calculating the continuation rate is derived from the definition of the continuation rate. The continuation rate is defined as

$$C = (R + C_n)/N, \quad (F-1)$$

where C is the continuation rate, R is the number of reenlistments, C_n is the number of individuals who are not at a decision-making point in their career and, thus, are simply continuing from one year of service cohort to the next, and N is

Table F-1. Continuation Rates by Year of Service

Scenario 1 First Term = .4772 Second Term = .5608 Career = .9275				Scenario 2 First Term = .5772 Second Term = .6608 Career = .9575			
YEAR 0:	.901	YEAR 17:	.995	YEAR 0:	.901	YEAR 17:	.995
YEAR 1:	.894	YEAR 18:	.994	YEAR 1:	.894	YEAR 18:	.994
YEAR 2:	.901	YEAR 19:	.500	YEAR 2:	.901	YEAR 19:	.500
YEAR 3:	.751*	YEAR 20:	.665	YEAR 3:	.787*	YEAR 20:	.665
YEAR 4:	.725*	YEAR 21:	.726	YEAR 4:	.765*	YEAR 21:	.726
YEAR 5:	.858*	YEAR 22:	.667	YEAR 5:	.879*	YEAR 22:	.667
YEAR 6:	.854	YEAR 23:	.773	YEAR 6:	.854	YEAR 23:	.773
YEAR 7:	.905*	YEAR 24:	.838	YEAR 7:	.922*	YEAR 24:	.838
YEAR 8:	.882*	YEAR 25:	.532	YEAR 8:	.904*	YEAR 25:	.532
YEAR 9:	.889*	YEAR 26:	.671	YEAR 9:	.909*	YEAR 26:	.671
YEAR 10:	.973*	YEAR 27:	.517	YEAR 10:	.978*	YEAR 27:	.517
YEAR 11:	.974*	YEAR 28:	.691	YEAR 11:	.979*	YEAR 28:	.691
YEAR 12:	.978*	YEAR 29:	.155	YEAR 12:	.983*	YEAR 29:	.155
YEAR 13:	.983	YEAR 30:	.000	YEAR 13:	.983	YEAR 30:	.000
YEAR 14:	.989	YEAR 31:	.000	YEAR 14:	.989	YEAR 31:	.000
YEAR 15:	.989	YEAR 32:	.000	YEAR 15:	.989	YEAR 32:	.000
YEAR 16:	.994	YEAR 33:	.000	YEAR 16:	.994	YEAR 33:	.000

* Year of service affected by the reenlistment rate.

the starting inventory. $(R + C_n)$, then, is the total number of personnel continuing from one year of service cohort to the next. Equation (F-1) can be expanded to

$$C = (R + (N-D))/N, \quad (F-2)$$

where D is the number of eligible and ineligible decision-makers at a decision-making point in their career, and $(N-D)$ is equal to C_n . Since the number of reenlistments, R , is equal to the product of the reenlistment rate and the eligible population, equation (F-2) can be expanded to

$$C = ((P_r * D_e) + N - D)/N, \quad (F-3)$$

where P_r is the probability of reenlistment and D_e is the number of decision-makers who are eligible to reenlist. Expanding equation (F-3) provides

$$C = ((P_r * D_e)/N) + 1 - (D/N). \quad (F-4)$$

Since D_e is the product of the proportion of the decision-making population which is eligible to reenlist, (D_e/D) , and the total number of decision-makers, D , equation (F-4) can be rewritten as

$$C = (P_r * (D_e/D) * (D/N)) + 1 - (D/N). \quad (F-5)$$

Probability of reenlistment and eligibility to reenlist are assumed to vary by category of enlistment, whereas the proportion of decision-makers varies by year of service transition point. For the first term, the proportion of decision-makers at the 3- to 4-year transition point is (D/N) or 0.4225, 0.4664 at the 4- to 5-year point, and 0.2409 at the 5- to 6-year point, while the proportion of eligible decision-makers, (D_e/D) , is 0.8591. For the second term, the proportion of decision-makers is 0.1929 at the 7- to 8-year point, 0.2384 at the 8- to 9-year point, and 0.2249 at the 9- to 10-year point, while the proportion of eligible decision-makers is 0.9022. For career, the proportion of decision-makers is 0.2026 at the 10- to 11-year point, 0.1952 at the 11- to 12-year point, and 0.1611 at the 12- to 13-year point, while the proportion of eligible decision-makers is 0.9332.

In Figure E-2, scenario 1 assumes a first-term reenlistment rate of 0.4772. Substituting into equation (F-5) provides

$$C_{f1} = (0.4772 * 0.8591 * 0.4225) + 1 - (0.4225) = 0.751, \quad (F-6)$$

where C_{f1} is the continuation rate for the 3- to 4-year point, which is affected only by the first-term reenlistment rate. Similar calculations can be performed for each of the other eight year of service decision points, providing the results presented in Table F-1.

The proportions for (D_e/D) and (D/N) by category of enlistment and year of service decision point may fluctuate over time as a result of changes in economic conditions and policy. The proportions provided in the previous discussion were estimated from the 1982 through 1985 personnel inventories using components of the Airman Gain/Loss File and the Uniform Airman Record File which are included in the Historical Airman Data (HAD) Base residing on the AFHRL computer.

APPENDIX G: DETAILED DISCUSSION OF OUTPUT TABLES

Summary Table

The summary table (Figure G-1) is comprised of six columns. Column 1 provides the year of the projection, 1 through 10, depending on the number of year(s) the user chose to project in Screen 5, prompt D. Column 2 presents the number of accessions which are necessary to meet the desired inventory selected by the user in Screen 6, prompt F. The number of accessions is also affected by the desired inventory level and the reenlistment rates which, in turn, affect the number of losses to the inventory per projection year. The third column provides the number of losses to the inventory which may or may not equal the number of accessions, depending on whether the user opted to increase, decrease, or maintain the inventory level in Screen 6, prompt F. The fourth column shows the number of prior-service recruits which comprise a part of the total accessions in column 2. The number of prior-service recruits is constrained by the user in Screen 6, prompt F2, and affected by the number of accessions in column 2. Columns 5 and 6 present the end-of-projected-year inventory and the original inventory, respectively. In the event that force reductions cannot be met through separations, the program will display in column 5 the attainable force level given the reenlistment rate and 0.0 accessions.

The original inventory is the inventory which exists at the beginning of the analysis and, thus, does not change over the projected years. The end-of-the-projected-year inventory is determined by the user in Screen 6, prompt F. For the AFS, the end-of-the-year inventory represents a desired manning level which the software is programmed to meet at the end of each projected year.

**Air Force Retention Analysis Package, Ver. 4.0
Specialty 272x0
Summary Table**

YR	TOTAL ACCESSIONS	TOTAL LOSSES	TOTAL PRIOR SERVICE	SIZE OF FORCE	ORIGINAL SIZE
1	669	669	0	5880	5880
2	631	631	0	5880	5880
3	628	628	0	5880	5880
4	614	614	0	5880	5880
5	597	597	0	5880	5880

Figure G-1. Summary Table.

Year-by-Year Projection Table

The year-by-year projection table (Figure G-2) presents the results of imposing the user-defined scenario (Screens 5 and 6) on the personnel inventory of the AFS. Column 1 provides the YOS cohort which ranges from 0 to 33, and column 2 presents the original inventory. All columns beyond column 2 present the end-of-year inventory for each projected year (Screen 5, prompt D), beginning with the first projected year and proceeding to the last projected year.

**Air Force Retention Analysis Package, Ver. 4.0
Specialty 272x0**

YOS	BASE YR	PROJ YR 1	PROJ YR 2	PROJ YR 3	PROJ YR 4	PROJ YR 5
0	448	669	631	628	614	597
1	476	404	603	568	566	553
2	364	426	361	539	508	506
3	359	328	383	325	486	458
4	491	292	267	312	264	395
5	500	390	232	212	248	210
6	414	447	349	207	189	221
7	299	354	382	298	177	162
8	303	279	330	356	278	165
9	267	278	256	302	327	255
10	244	246	256	236	279	301
11	229	236	238	248	228	270
12	209	222	228	230	240	221
13	162	203	216	222	224	233
14	122	159	200	212	218	220
15	109	121	157	198	210	216
16	157	108	119	156	119	207

Figure G-2. Year-by-Year Projection Table.

**Air Force Retention Analysis Package, Ver. 4.0
Specialty 272x0**

YOS	BASE YR	PROJ YR 1	PROJ YR 2	PROJ YR 3	PROJ YR 4	PROJ YR 5
17	158	156	107	119	155	194
18	136	157	155	107	118	154
19	123	135	156	154	106	117
20	115	62	68	78	77	53
21	54	76	41	45	52	51
22	37	39	56	30	33	38
23	30	25	26	37	20	22
24	22	23	19	20	29	15
25	32	18	19	16	17	24
26	7	17	10	10	9	9
27	2	5	11	7	7	6
28	6	1	2	6	3	4
29	5	4	1	2	4	2
30	0	1	1	0	0	1
31	0	0	0	0	0	0
32	0	0	0	0	0	0
33	0	0	0	0	0	0

Figure G-2. Year-by-Year Projection Table (Concluded)

The Year of Service Distribution Table

The year of service distribution table (Figure G-3) provides the user with several options for analyzing the results of a selected scenario by comparing the original inventory with other user-selected inventories (Screen 7, prompts L1 and L2). Column 1 presents the YOS cohorts, beginning with 0 and ranging through 33. Column 2 provides the original inventory with which the analysis begins. In the example, the original or base year is the most recently available inventory for AFS 272x0. Column 3 provides the resulting inventory for the last projected year as selected by the user in Screen 5, prompt D. This inventory represents the effect of the user-defined scenario over the projected years.

Column 4 presents the difference between column 2 (the original inventory) and column 3 (the inventory of the last projected year). Thus, column 4 is the change in the experience distribution of the personnel inventory from the original inventory to the last projected inventory as affected by the user-defined scenario imposed on each of the projected years. The fifth and sixth columns will vary depending on the selection of the user in Screen 7, prompts L1 and L2. If the user selects (P)redicted profile in prompt L1, then one of the end-of-year projected inventories will be provided in column 5 as determined in prompt L2. Column 6 will then present the YOS-by-YOS difference between the projected inventory in column 5 and the original inventory in column 2. If the user selects (D)esired profile in L1, then an intermediate screen will appear to the user, which will provide an opportunity to develop a desired or optimal experience distribution for the personnel inventory, Screen 7a. The desired inventory will be presented in column 5, and column 6 will be the YOS-by-YOS difference between the desired inventory in column 5 and the resulting inventory of the last projected year in column 3. This inventory comparison provides the user with an indicator of how well certain policy variables changed or selected in RAP (e.g., bonus and/or military compensation) attained their desired effect on the experience distribution of the personnel inventory for the AFS.

Air Force Retention Analysis Package, Ver.4.0
Specialty 272x0

YOS	BASE YR JUNE 86	PROJECTED YR 5	DIFFERENCE YR 5-BASE	PROJECTED YR 2	DIFFERENCE YR 2-BASE
0	448	885	437	858	410
1	476	722	246	811	335
2	364	694	330	361	-3
3	359	623	264	383	24
4	491	347	-144	174	-317
5	500	148	-352	163	-337
6	414	143	-271	346	-68
7	299	91	-208	305	6
8	303	85	-218	263	-40
9	267	180	-87	210	-57
10	244	202	-42	235	-9
11	299	189	-40	234	5
12	209	170	-39	210	1
13	162	198	36	208	46
14	122	208	86	201	79
15	109	187	78	148	39
16	157	175	18	105	-52

Figure G-3. Year of Service Distribution Table.

**Air Force Retention Analysis Package, Ver.4.0
Specialty 272x0**

YOS	BASE YR JUNE 86	PROJECTED YR 5	DIFFERENCE YR 5-BASE	PROJECTED YR 2	DIFFERENCE YR 2-BASE
17	158	172	14	100	-58
18	136	135	-1	155	19
19	123	103	-20	156	33
20	115	50	-65	68	-47
21	54	51	-3	41	-13
22	37	38	1	56	19
23	30	22	-8	26	-4
24	22	15	-7	19	-3
25	32	24	-8	19	-13
26	7	9	2	10	3
27	2	6	4	11	9
28	6	4	-2	2	-4
29	5	2	-3	1	-4
30	0	1	1	1	1
31	0	0	0	0	0
32	0	0	0	0	0
33	0	0	0	0	0

Figure G-3. Year of Service Distribution Table (Concluded)

Reenlistment Comparison Table

The reenlistment comparison table (Figure G-4) allows the user to analyze differences in the reenlistment behavior between scenarios. In the example, two scenarios are being compared for AFS 272x0 which involve a 3-year projection with differing policy values. Column 1 provides the projected year, which ranges from 1 to a maximum of 10, depending on the user's response in Screen 5, prompt D. Columns 2, 3, and 4 present the differences in the inventories for first-term, second-term, and career airman, respectively, for each of the projected years. In the example, the -7 in the first row of column 2 implies that the new scenario produced seven fewer first-term airmen in the first projection year versus the original or base scenario. Similarly, -25 in the second row of column 2 implies 25 fewer first-term airmen remained in the Air Force in the new scenario. The comparison for the career term indicates that 89 more airmen are remaining in the service under the new versus the original scenario. Column 5 presents the difference between the accession requirements for each scenario by projection year.

**Air Force Retention Analysis Package, Ver.4.0
Specialty 272x0**

PROJ YR	COMPARISON FIRST-SCEN	COMPARISON SECOND-SCEN	COMPARISON CAREER-SCEN	COMPARISON ACCESSIONS
1	-7	-70	89	-12
2	-25	-129	176	-23
3	-45	-158	249	-49

Figure G-4. Reenlistment Comparison Table.