

(2)

MISCELLANEOUS PAPER SL-89-2

PRELIMINARY SOUND-ABATEMENT TESTS USING SHOCK-ATTENUATING CONCRETE (SACON) AND OTHER MATERIALS, BIG BLACK TEST FACILITY

by

William L. Huff, Gary L. Carre, Terry R. Stanton
Joe G. Tom, Robert H. Denson

Structures Laboratory

DEPARTMENT OF THE ARMY
Waterways Experiment Station, Corps of Engineers
3909 Halls Ferry Road
Vicksburg, Mississippi 39180-6199

DTIC FILE COPY



DTIC
ELECTE
SEP 20 1989
S B D

August 1989
Final Report

Approved For Public Release, Distribution Unlimited

Prepared for DEPARTMENT OF THE ARMY
US Army Corps of Engineers
Washington, DC 20314-1000

Under Project No. 4A62719AT40

89 9. 18 166

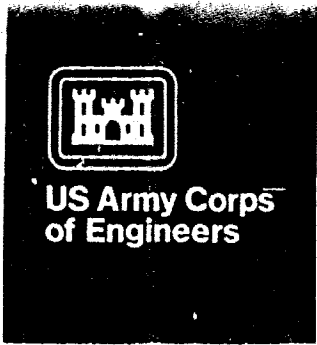

AD-A212 816

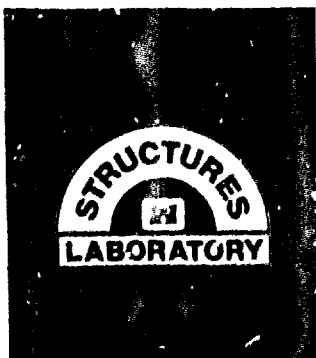

When this report is no longer needed return it to
the originator.

The findings in this report are not to be construed as an
official Department of the Army position unless so
designated by other authorized documents.

The contents of this report are not to be used for
advertising, publication, or promotional purposes.
Citation of trade names does not constitute an
official endorsement or approval of the use of such
commercial products.

Unclassified

SECURITY CLASSIFICATION OF THIS PAGE

REPORT DOCUMENTATION PAGE				Form Approved OMB No 0704 0188 Exp Date Jun 30 1986	
1a REPORT SECURITY CLASSIFICATION Unclassified		1b RESTRICTIVE MARKINGS			
2a SECURITY CLASSIFICATION AUTHORITY		3 DISTRIBUTION/AVAILABILITY OF REPORT Approved for public release; distribution unlimited.			
2b DECLASSIFICATION/DOWNGRADING SCHEDULE		4 PERFORMING ORGANIZATION REPORT NUMBER(S) Miscellaneous Paper SL-89-2			
4 PERFORMING ORGANIZATION REPORT NUMBER(S)		5 MONITORING ORGANIZATION REPORT NUMBER(S)			
6a NAME OF PERFORMING ORGANIZATION JSAEWES Structures Laboratory		6b OFFICE SYMBOL <i>(if applicable)</i>	7a NAME OF MONITORING ORGANIZATION		
6c ADDRESS (City, State, and ZIP Code) 3909 Halls Ferry Road Vicksburg, MS 39180-6199		7b ADDRESS (City, State, and ZIP Code)			
8a NAME OF FUNDING / SPONSORING ORGANIZATION US Army Corps of Engineers		8b OFFICE SYMBOL <i>(if applicable)</i>	9 PROCUREMENT INSTRUMENT IDENTIFICATION NUMBER		
8c ADDRESS (City, State, and ZIP Code) Washington, DC 20314-1000		10 SOURCE OF FUNDING NUMBERS			
		PROGRAM ELEMENT NO	PROJECT NO	TASK NO	WORK UNIT ACCESSION NO
11 TITLE (Include Security Classification) Preliminary Sound-Abatement Tests Using Shock-Attenuating Concrete (SACON) and Other Materials, Big Black Test Facility					
12 PERSONAL AUTHOR(S) Huff, William L., Carre, Gary L., Stanton, Terry R., Tom, Joe G., and Denson, Robert H.					
13a TYPE OF REPORT Final report		13b TIME COVERED FROM Feb 1989 TO Mar 1989	14 DATE OF REPORT (Year, Month, Day) August 1989		15 PAGE COUNT 21
16 SUPPLEMENTARY NOTATION Available from National Technical Information Service, 5285 Port Royal Road, Springfield, VA 22161.					
17 COSATI CODES			18 SUBJECT TERMS (Continue on reverse if necessary and identify by block number)		
FIELD	GROUP	SUB-GROUP	Igloo	Sound abatement	
			Molded expanded polystyrene	Sound measurements	
			Shock-attenuating concrete	Tunnel	
19 ABSTRACT (Continue on reverse if necessary and identify by block number) Two structural concepts, a tunnel and an igloo, were constructed at the US Army Engineer Waterways Experiment Station using a shock-attenuating concrete (SACON) to determine the possible sound-abatement properties. Both structures and the SACON displayed sound abatement properties, as registered on hand-held sound level meters, when an M-16-A1 rifle was fired in certain positions in and near the two structures. A noticeable reduction in sound was obtained by the use of the material and configurations of the two structures.					
20 DISTRIBUTION AVAILABILITY OF ABSTRACT <input checked="" type="checkbox"/> UNCLASSIFIED/UNLIMITED <input type="checkbox"/> SAME AS RPT <input type="checkbox"/> DTIC USERS			21 ABSTRACT SECURITY CLASSIFICATION Unclassified		
22a NAME OF RESPONSIBLE INDIVIDUAL			22b TELEPHONE (Include Area Code)		22c OFFICE SYMBOL

DD FORM 1473, 34 MAR

83 Edition may be used until exhausted
All other editions are obsolete

SECURITY CLASSIFICATION OF THIS PAGE

Unclassified

10
19
14
1

Preface

The work reported in this study was performed by personnel of the US Army Engineer Waterways Experiment Station (WES) as requested in December 1988 by COL Dwayne G. Lee, EN, Commander and Director of WES. Funding for this study was provided by Headquarters, US Army Corps of Engineers, under Project No. 4A62719AT40.

The construction and testing were conducted by personnel from the Structures Laboratory (SL), WES, under the general supervision of Messrs. Bryant Mather, Chief, SL, James T. Ballard, Assistant Chief, SL, Kenneth L. Saucier, Chief, Concrete Technology Division (CTD), and Dr. Jimmy P. Balsara, Chief, Structural Mechanics Division (SMD). The study was conducted under the direct supervision of Program Manager, Mr. Richard L. Stowe, CTD, and Team Leaders, Mr. William L. Huff, SMD, and Dr. Robert H. Denson, CTD. This report was prepared by Messrs. Huff, Gary L. Carre, and CPT Terry R. Stanton, SMD, Mr. Joe G. Tom, and Dr. Denson, CTD. Final editing for publication of this report was provided by Mrs. Gilda Miller, Information Products Division, Information Technology Laboratory, WES.

Acting Commander and Director of WES during preparation of this report was LTC Jack R. Stephens, EN. Technical Director was Dr. Robert W. Whalin.

Accession For	
DTIC GRA&I	<input checked="" type="checkbox"/>
DTIC TAB	<input type="checkbox"/>
Unannounced	<input type="checkbox"/>
Justification	
By _____	
Distribution/	
Availability Codes	
Dist	Avail and/or Special
A-1	

Contents

	<u>Page</u>
Preface.	1
Conversion Factors, Non-SI to SI (Metric) Units of Measurement	3
Introduction	4
Materials and Mixture Proportions.	4
Form Construction.	5
Mixing Procedure and Casting	6
SACON Compressive Strength Tests	6
Site Preparation and Test Structures Construction.	6
Test Procedures.	8
Tunnel Concept	9
Igloo Concept.	10
Box Test	10
Test Summary	11
Conclusions and Recommendations.	12
References	13
Figures 1-8	

Conversion Factors, Non-SI to SI (Metric)
Units of Measurement

Non-SI units of measurement used in this report can be converted to SI (metric) units as follows:

<u>Multiply</u>	<u>By</u>	<u>To Obtain</u>
cubic feet	0.02831685	cubic metres
cubic yards	0.7645549	cubic metres
degrees (angle)	0.01745	radians
feet	0.3048	metres
inches	25.4	millimetres
pounds (force) per square inch (psi)	0.006894757	megapascals
pounds (mass)	0.4535924	kilograms
pounds (mass) per cubic foot (pcf)	16.01846	kilograms per cubic metre

PRELIMINARY SOUND-ABATEMENT TESTS USING SHOCK-ATTENUATING CONCRETE (SACON)
AND OTHER MATERIALS
BIG BLACK TEST FACILITY

Introduction

1. The Concrete Technology Division (CTD) of the Structures Laboratory (SL), US Army Engineer Waterways Experiment Station (WES), was tasked in 1975 by Headquarters, US Army Corps of Engineers, to develop a material for use in the construction of live-fire (M-16) Military Operations in Built-Up Areas/Military Operations in Urban Terrain (MOBA/MOUT) training villages. The candidate material or system was required to (a) prevent ricochets, (b) prevent spalling, and (c) be conducive to use by troop labor for construction and maintenance. Preliminary developmental research testing at CTD on approximately 28 different mixtures indicated that six of these mixtures exhibited potential for successful response to M-16 rifle fire while meeting the three basic requirements. Subsequent tests (Denson et al. 1984) were conducted at Ft. Bragg, NC, on six primitive structures constructed using concrete mixtures proportioned in accordance with the generic shock-attenuating concrete (SACON) family of mixtures. The project mixtures were composed of two categories of portland-cement concrete: (preformed foam and expanded polystyrene beads (EPSB)), each with steel fibers, polypropylene fibers, or alkali-resistant glass fibers for reinforcement. Firing tests indicated that the six mixtures performed successfully, with the steel fiber-foamed concrete (designated WES 6) being the best performer. Mixture WES 6 has since been used successfully for (a) room-clearing training structure (M-16 and fragmentation grenade), Ft. Benning, GA, (b) berm and pop-up target mechanism protection (M-16), Grafenwehr, West Germany, and (c) full-scale mockup of Russian tanks (helicopter weaponry targets), Ft. Hood, TX.

Materials and Mixture Proportions

Materials

2. The mixture (designated SACON 50) used for this test is a derivation of the SACON mixture, WES 6, used at Ft. Bragg. The two main differences between them are (a) SACON 50 contains none of the fiber reinforcement found

in WES 6, and (b) SACON 50 has a nominal unit weight of 50 pcf*, whereas WES 6 has a unit weight of 95 pcf. SACON 50 is composed of Type I cement, a fine aggregate meeting the requirements of the American Society for Testing and Materials (ASTM) C 33 (ASTM 1986a), a preformed proprietary foam, and water.

Mixture proportions

3. Table 1 lists the quantities per cubic yard of the constituent materials in SACON 50.

Table 1
SACON 50
Mixture Proportions

<u>Material</u>	<u>Quantity Per Cubic Yard</u>
Cement	556 lb
Water	239 lb
Sand	556 lb
Foam	17 cu ft

Form Construction

4. Wooden forms were built for casting building elements used to construct the two structures for the live-fire portion of this investigation.

5. The forms were designed to provide support to the SACON 50 for movement during transportation to the site, onsite, and during actual construction. The forms were constructed of 3/4-in. plywood held together with wood screws. The bottom of the form was the same area size as the SACON 50 panels and blocks and provided additional support while the material was being handled and physically moved into different positions. This operation allowed the labor force to position the SACON 50 panels into place prior to removing the forms. The forms were then removed by power screwdrivers.

6. There were three different sizes of forms constructed for this project: the tunnel required sixteen 3- by 4-ft by 6-in.-thick panels; the igloo

* A table of factors for converting non-SI units of measurement to SI (metric) units is presented on page 3.

required twenty-four 1-ft-cube blocks plus three 1- by 7-ft by 6-in.-thick roof panels. All the forms were completed prior to casting thus allowing for a single casting of the SACON 50. Though the method of construction allowed form reuse, the time constraints placed on the project would not allow multiple casting.

Mixing Procedure and Casting

7. Once all the forms were constructed and coated with silicone spray, the sanded portland-cement slurry was obtained in a truck mixer from a local supplier. The preformed foam, in less than the required amount, was added to the truck drum and thoroughly mixed with the slurry. A unit weight check was conducted on the foamed slurry and any additional foam was added as needed. This procedure was repeated as necessary until the proper unit weight was achieved. The foamed slurry was then discharged into the forms and the forms covered with sheet polyethylene for curing. Once the SACON had gained some strength (after a few hours), the surface was scarified with a device using nail points. The various building elements were left in the forms during transportation to the Big Black Test Facility located 9 miles southeast of Vicksburg, MS, on the Big Black River. These elements were used to construct the various structural configurations for testing.

SACON Compressive Strength Tests

8. Cylindrical SACON specimens, measuring 6 in. in diam by 12 in. high, were cast during the placement operation and were used to determine the unconfined compressive strength (ASTM 1986b) of the material. The average value of four cylinders showed the 28-day unconfined compressive strength to be 40 psi.

Site Preparation and Test Structures Construction

9. After a 3-week period of curing and strength gain, the SACON 50 test panels and test blocks were transported in the forms to the Big Black Test Site. Each SACON 50 tunnel panel and form weighed approximately 300 lb, each igloo block weighed about 50 lb, and each igloo roof panel weighed about 175 lb. The panels were loaded onto a flat bed truck with a forklift and the

blocks were loaded by hand. A two-wheel hand truck and a boom crane at the site were used to unload the test panels and blocks.

10. A minimal amount of surface preparation was required at the site to provide a fairly level area. Immediately following the baseline firing and sound decibels (dB) measurements for the test area, an enclosed structure was constructed using the tunnel panels as a floor, a roof, and three of the four walls. The fourth wall was made from the igloo blocks that allowed for dismantling the wall for monitoring and resetting the sound level meters.

11. The next test configuration was the tunnel. The tunnel was designed in four 3-ft-long sections of consecutive overlapping panels; the 3-ft-wide end of each panel was placed against the adjacent face. This panel and construction technique allows all the tunnel panels to be the same dimensions. During the curing phase of the SACON 50, the face of each panel was scarified using a serrated nail point screed, giving the SACON 50 a rough texture, increasing the surface area exposed to the sound wave, and providing a baffling system within the tunnel. One 6-in. portion of the face was left unscarified to provide a load-bearing surface for the butted end of the adjacent panel. Wooden support frames were used inside the tunnel to support the roof panel.

12. Following the firing tests and dB measurements on the tunnel, the construction crew began construction of the igloo structure. The igloo site was moved approximately 20 ft away in a 45-deg angle direction from the tunnel, thus losing only one dB test location back toward the tunnel. The 90-deg angle directions were considered the most important test directions and were maintained.

13. The igloo structure is a lattice system, pyramidal in shape. The bottom row of blocks were spaced approximately 2 in. apart in a circular fashion with two openings, one on each end. The second row of blocks were again spaced 2 in. apart, but each block was centered over the space or joint of the bottom row. The third and final row of blocks were spaced over the spaces of the second row of blocks. The three roof panels were placed into position over and centered with the third row of blocks and were supported over the middle 5-ft span by two wooden frames.

Test Procedures

14. A relatively flat open area was selected for the test area in an attempt to match conditions on a small arms range as much as possible. Clear distances of at least 100 ft were maintained in all directions. Although earth berms and wooded sections at the area most likely generated sound reflections, these apparently did not affect the data. Figure 1 demonstrates the general layout of the measurement locations. The firing point was located in the center with measuring points located 100 ft from the center at 45-degree angles. The direction of fire was from the firing point toward point A. Because of emphasis to the rear and sides of the firing point, six additional points were added at distances of 10, 20, and 40 ft along axes FC and AE.

15. Three Larson Davis Model 700 (1985) hand-held sound level meters were used to record data. The devices have the following characteristics:

Dynamic range	35 to 175 dB, with an overload indicated on the screen above 150 dB
Single pulse response	Less than 1.5 dB error for a single cycle of 1 KHz at 140 dB
Effect of humidity	Less than 0.5 dB error with 90 percent humidity at 40° C (104° F)
Effects of temperature	Less than 0.5 dB error from -18° C (0° F) to 49° C (120° F)

The maximum value for the dynamic range initially caused some concern, since other sources reported sound levels around 155 dB for the M-16-A1 rifle. During the test, however, overloads were recorded only three times and this occurred when the meter was placed within 1 ft of the weapon. Several values were recorded around the 150-dB level without an overload indicated. This led to the conclusion that the dynamic range was device specific and for these meters it was slightly higher than 150 dB.

16. Baseline sound levels were recorded during each day of testing and are presented in Figure 1. The values in Figure 1 represent the average of six data records. The six records are the peak values from two meters located at a point during three shots. As would be expected, the data show that sound levels in front of the weapon were the highest. Also, as the measuring point was moved around the arc from point A to point E, the sound levels decreased. It should be noted that weather conditions during the 4 days of testing remained very nearly the same, cool and overcast with some rain.

17. As mentioned previously, two prototype structures were tested in this study. Peak sound levels were recorded in the same manner as the baseline records discussed earlier. During these shots, the weapon was fired through the structure and the values, again, represent the average of six data records (same as baseline). Results are compared with the baseline values later in this report. Also tested were two divergent materials, SACON 50 and molded expanded polystyrene beads (MEPSB). This was done to get a feel for sound reduction for the SACON 50 as compared to the MEPSB.

Tunnel Concept

18. This prototype consisted of sixteen 3- by 4-ft by 6-in. SACON 50 slabs arranged in a rectangular tunnel fashion (Figure 2). The total structure was 12 ft long and had a square opening of approximately 3 ft 6 in. The length selected represents the minimum size required to attenuate a muzzle blast for a 3-ft-high structure (Raspet 1987). The tunnel was constructed at the center of the test site and oriented so that the rifleman, looking through the tunnel, would see point A (Figure 3). A support was constructed at one end of the tunnel to locate the weapon at the same point for each shot. During test shots, the barrel of the weapon was located in the center of the tunnel opening about 6 in. into the tunnel (Figure 2). The rifleman aimed through the tunnel opening in the direction of point A.

19. Figure 3 shows the peak values from the tunnel test. The values in parentheses are the baseline values, and the values with no parentheses represent the data from shots fired through the tunnel. Tabulated values are data for the 10-, 20-, and 40-ft measurement points along axes FC and AE.

20. The reduction in sound level was of highest concern and obtained by subtracting the two numbers. No reduction was discovered to the front of or behind the tunnel (points A, E, E-10, E-20, and E-40). This was expected as these points are in line with the openings of the tunnel. About a 10-dB reduction was determined at points B and D. Points C and F had a reduction of about 25 dB (also points C-10, C-20, and C-40).

21. This led to the conclusion that when a material was placed between the sound source and the meter the sound levels would be reduced, with the maximum reduction occurring normal to the material. Data also showed that the sound reduction was symmetrical about both axes AE and FC.

Igloo Concept

22. This concept consisted of several 1-ft cubes of SACON 50 stacked similar to an igloo (Figure 4) and was constructed as delineated previously. The rifleman aimed through the structure toward point A (Figure 5). Again, a support was constructed to assist in positioning the weapon (Figure 4).

23. Figure 5 shows the results of the igloo test. The values are the peak sound levels measured at the corresponding points. Values in parentheses are baseline data, and the values with no parentheses are data from shots fired through the igloo. Tabulated values are data for the 10-, 20-, and 40-ft measurement points along axes FC and AE.

24. As with the tunnel concept, no reduction was determined to the front of the structure. However, a sound increase was measured to the rear of the structure (points E, E-10, E-20, and E-40). This was the only incident when the sound levels were increased. Data also showed the sound reduction was symmetrical only about axis AE. The conclusion derived from this was that the igloo structure could have tended to amplify the sound to the rear of the structure.

Box Test

25. This series of tests were conducted to evaluate the ability of SACON 50 to attenuate sound. The procedure consisted of testing a 4-ft-sq empty box made of SACON 50 and comparing the results to a box of the same size made of MEPSB. The SACON 50 box was constructed using the same slabs as in the tunnel concept test. One side of the box was made of the thicker 1-ft cubes, so that access to the inside of the box was possible. Measurements were taken inside and outside of the box while the weapon was fired from four different locations in the test arena (Figure 6). This same procedure was repeated with boxes of the same size constructed from 2- and 4-in.-thick MEPSB panels. Results are presented in Figures 6 through 8, respectively, for the SACON, 2- and 4-in. MEPSB material used in construction. The values in parentheses are outside measurements, and the values with no parentheses represent data measured from inside the box.

26. The results produced by SACON 50 showed a greater sound reduction than both the 2- and the 4-in. MEPSB panels (Table 2). However, the 4-in.

MEPSB panels did provide a greater reduction than the 2-in. MEPSB panels. From this it could be hypothesized that 6 in. of the MEPSB could have produced a similar reduction with the 4- and 6-in. thicknesses as was evident with the 2- and 4-in. thicknesses.

Table 2
Sound Reductions Recorded During Box Test

<u>Firing Point Location</u>	<u>2-in. MEPSB dB Reduction</u>	<u>4-in. MEPSB dB Reduction</u>	<u>SACON 50 dB Reduction</u>
Adjacent to the Box	9.5	17.5	19.0
Point E	17.5	27.0	33.0
Point A	12.5	20.0	12.5
Point F	18.5	22.5	28.0

Test Summary

27. Results of testing the two structural concepts showed that both provided some sound level reduction, with the maximum occurring normal to the material. Highest reductions were recorded during the tunnel test, with the solid barrier producing greater reductions than the lattice barrier (igloo concept). To determine if the same or greater reductions could have been obtained with other materials, the SACON 50 box test data were compared to results from two thicknesses of MEPSB. This comparison showed that SACON 50 produced greater reductions in sound levels than both 2- and 4-in.-thick MEPSB. However, there was an indication that a thickness of MEPSB the same as that of the SACON 50 (6 in.) could have produced enhanced sound abatement.

28. As a preliminary study of the sound produced by the M-16-A1 rifle and methods to reduce its sound signature, all attempts were made to limit the scope of this study as much as possible and to make maximum use of equipment on hand. Highest emphasis was placed on testing SACON 50 as a sound-abatement material. Future studies should concentrate on structural geometries or configurations that focus the signature in desired directions. Also, the evaluation of the optimal material (sound-attenuating) used in construction of these structures should be examined.

Conclusions and Recommendations

Conclusions

29. These preliminary tests have shown that (a) there are structural configurations that lend themselves to reducing sound levels (tunnel and igloo tests), and (b) SACON 50 exhibited the potential for reducing the sound (box test).

Recommendations

30. It is recommended that a research program be developed to address all the questions and potential gains that have been identified by this study. The program should (a) investigate materials and/or combinations of materials and various structural configurations that have potential for reducing sound levels on small arms firing ranges; (b) optimize the SACON 50 mixture to provide the best combination of strength and sound-attenuation properties; and (c) investigate combinations of WES 6 and SACON 50 to form a material that provides both safety and sound-attenuation properties.

References

American Society for Testing and Materials. 1986a. Test Methods and Specifications, Designation: C 33, "Specification for Concrete Aggregate," 1986 Book of ASTM Standards, Philadelphia, PA.

_____. 1986b. Test Methods and Specifications, Designation: C 39-86, "Test for Compressive Strength of Cylindrical Concrete Specimens," 1986 Book of ASTM Standards, Philadelphia, PA.

Denson, Robert H., Hoff, George C., Kopp, David L., Monahan, Alfred, and Tom, Joe G. 1984. "Materials Systems Investigation for MOBA/MOUT Live-Fire Training Villages," Miscellaneous Paper No. SL-84-12, US Army Engineer Waterways Experiment Station, Vicksburg, MS.

Larson Davis Laboratories. 1985. "Operation Manual, LDL Model 700 Dosimeter and Sound Level Meter with Memory," Pleasant Grove, UT.

Raspet, R. 1987. "Development and Description of a Computer Program for Prediction Impulse Noise Reduction by Barriers," Technical Report N-87/10, US Army Construction Engineering Research Laboratory, Champaign, IL.

POINT	DAY, dB			
	1	2	3	4
A	148.0	148.0	147.0	146.0
B	135.5	137.0	138.0	135.0
C	134.5	134.5	135.0	128.0
C-10				148.0
C-20				147.0
C-40				144.0
D	128.0	125.0	130.0	127.5
E	117.5	123.5	121.5	119.0
E-10				144.0
E-20				137.0
E-40				129.0
F	136.0	132.5	133.0	134.0

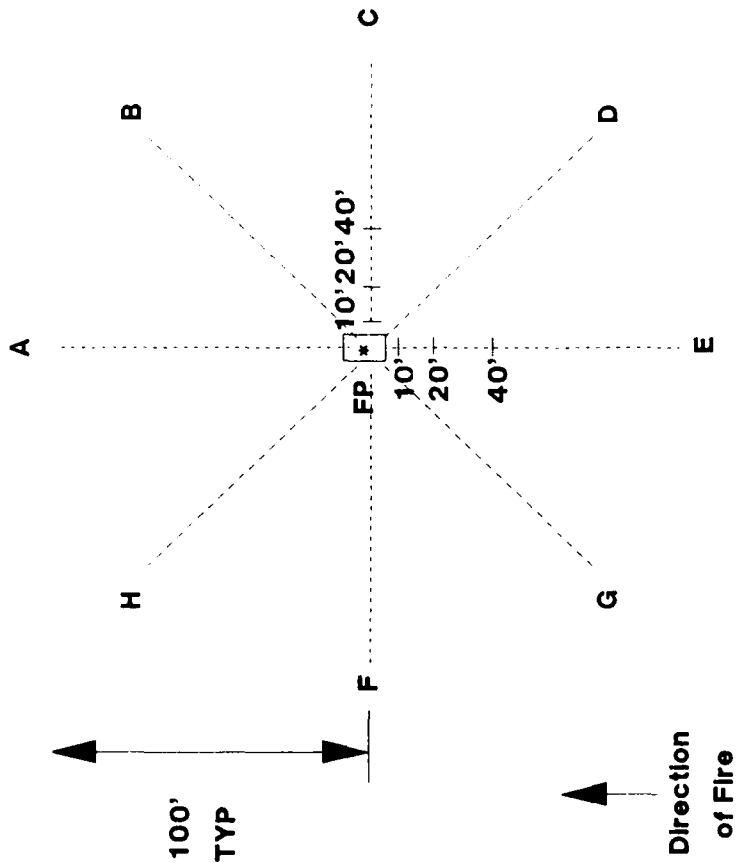

* Firing Point

Figure 1. Baseline sound levels (dB)

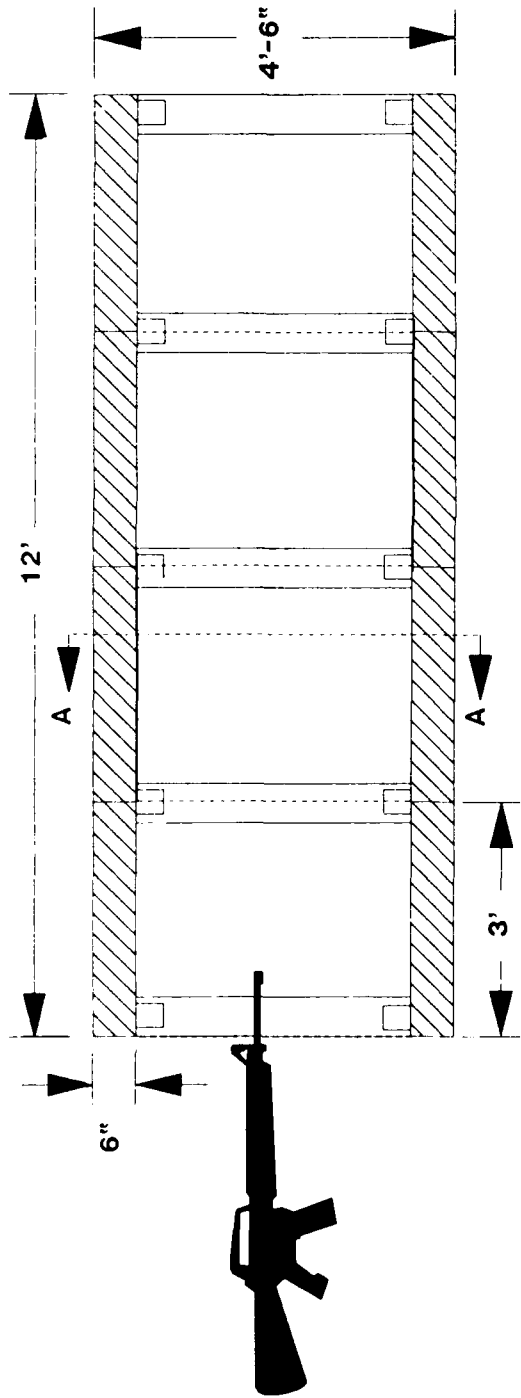

SIDE SECTION

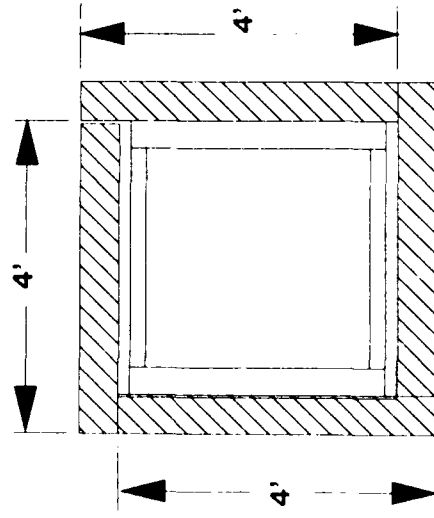

SECTION AA

Bill of Materials	
ITEM	NO REQ'D
6" SLABS	16
4"X4"X3'-3"	10
2"X6"X3'-6"	10
2"X4"X2'-11"	10

Figure 2. Tunnel Concept

POINT	dB
C-10	126.5 (148.0)
C-20	122.0 (147.0)
C-40	118.0 (144.0)
E-10	144.0 (144.0)
E-20	138.0 (137.0)
E-40	129.0 (129.0)

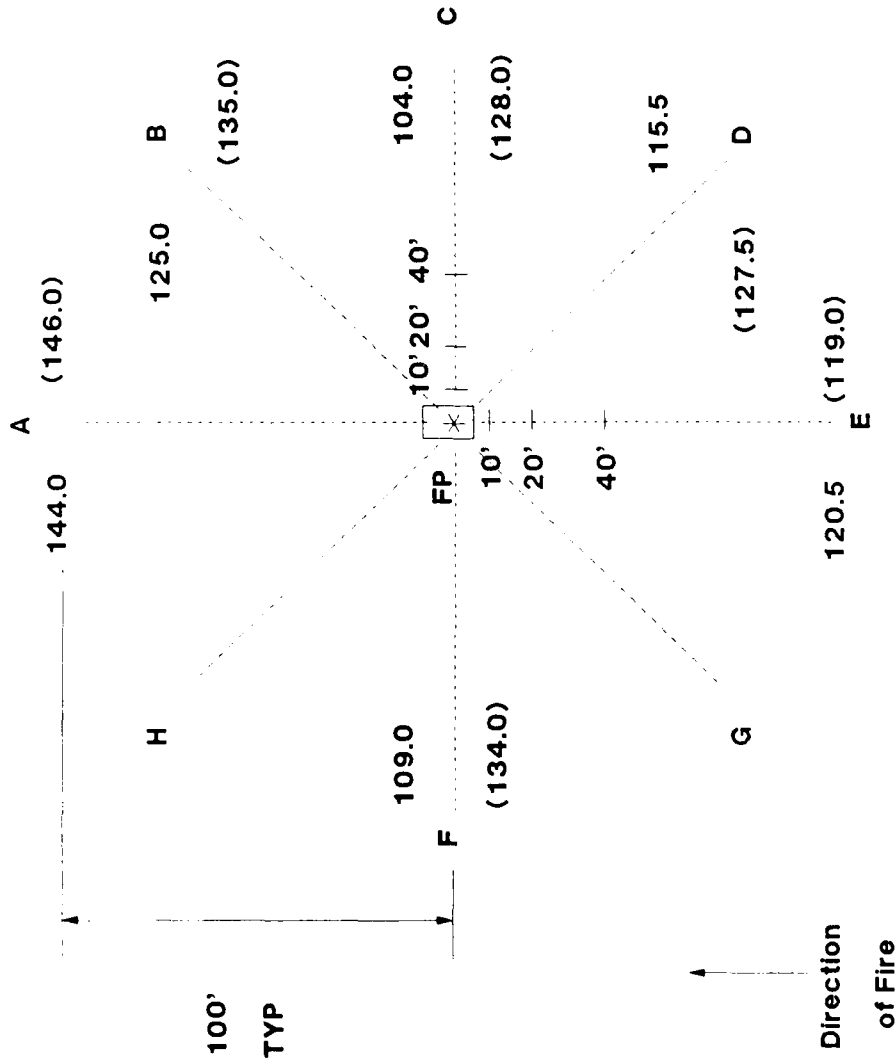

* Firing Point - FP
 --- dB Weapon Inside
 (-) dB Baseline

Figure 3. Tunnel structure results

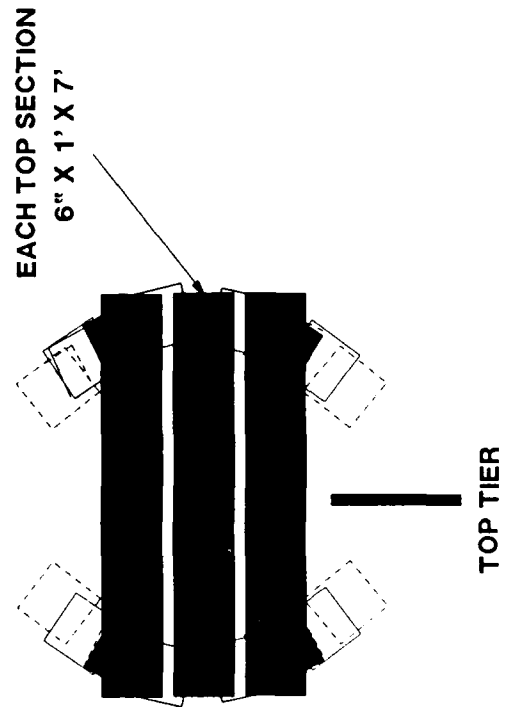
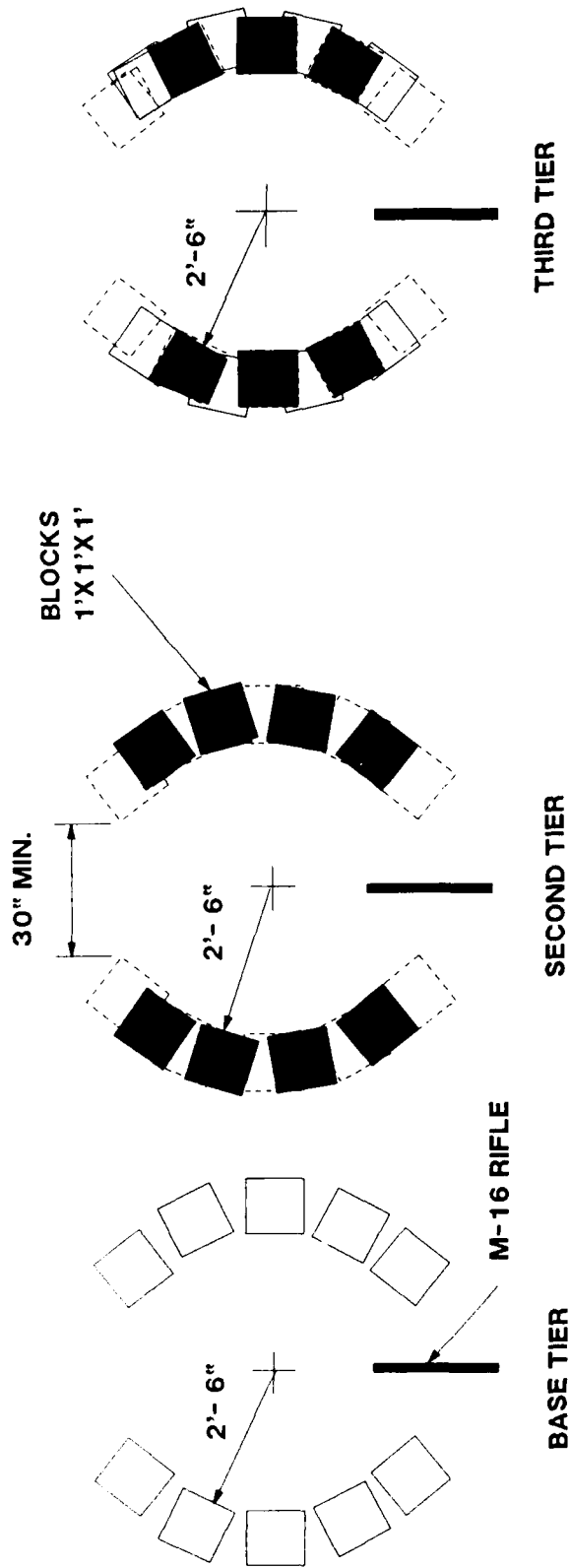

Bill of Materials

ITEM	NO REQ'D
SIDE BLOCKS	24
TOP SECTIONS	3

Figure 4. Igloo concept

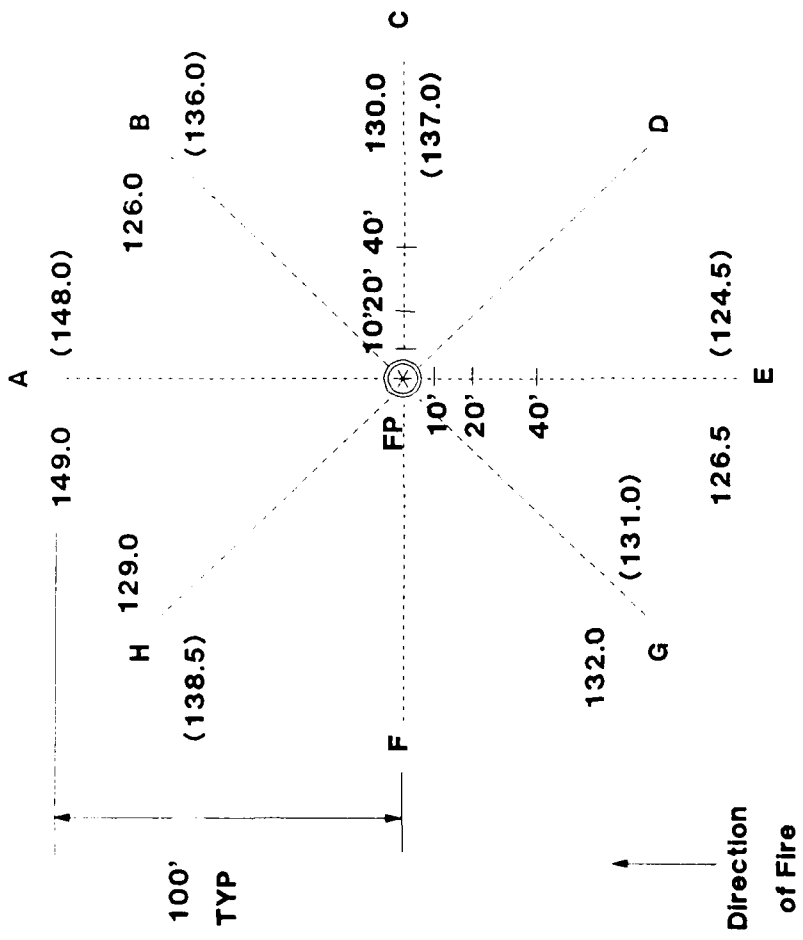

* Firing Point - FP
 — dB Weapon Inside
 () dB Baseline

Figure 5. Igloo structure results

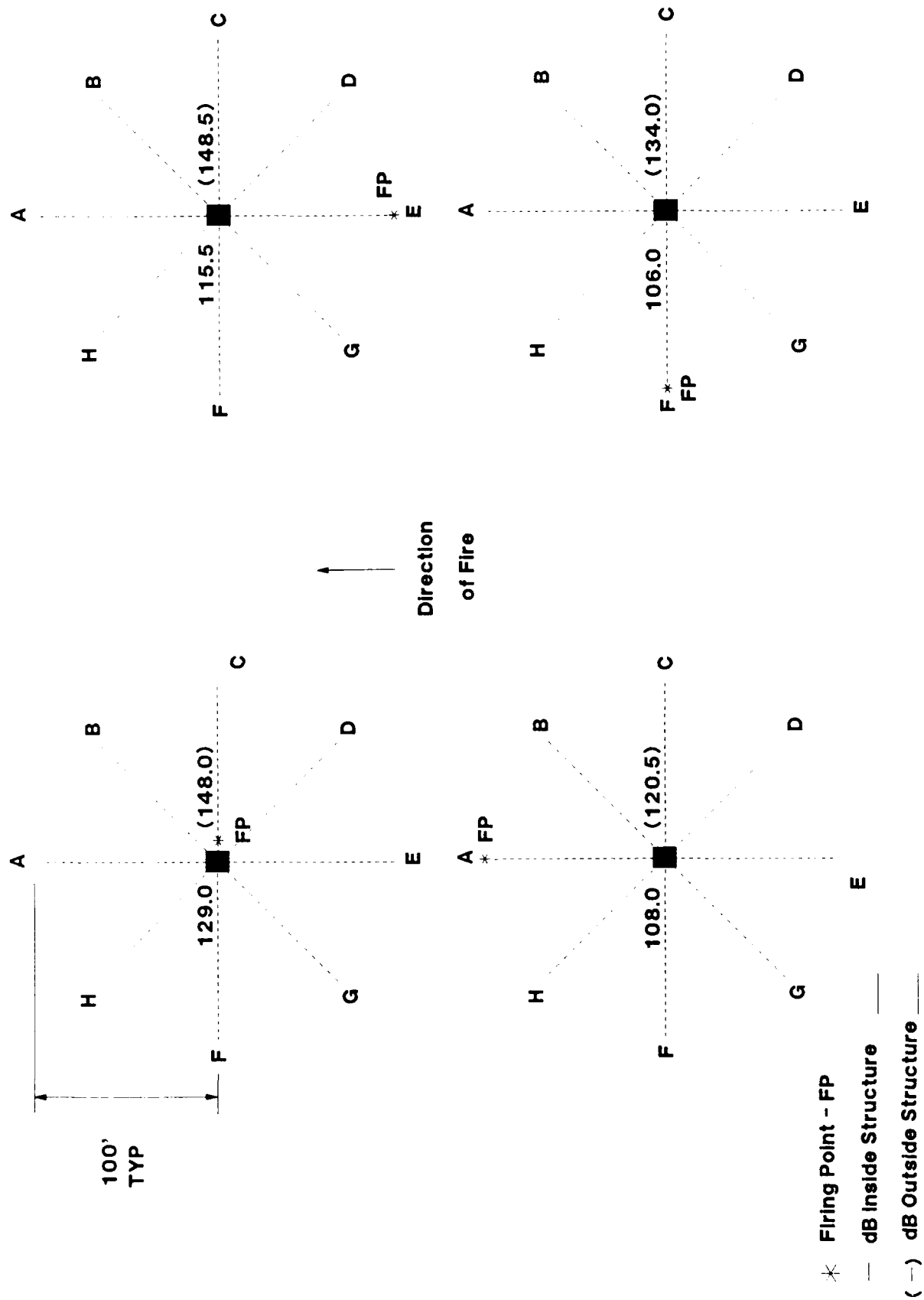

Figure 6. SACON box, 6 in. thick

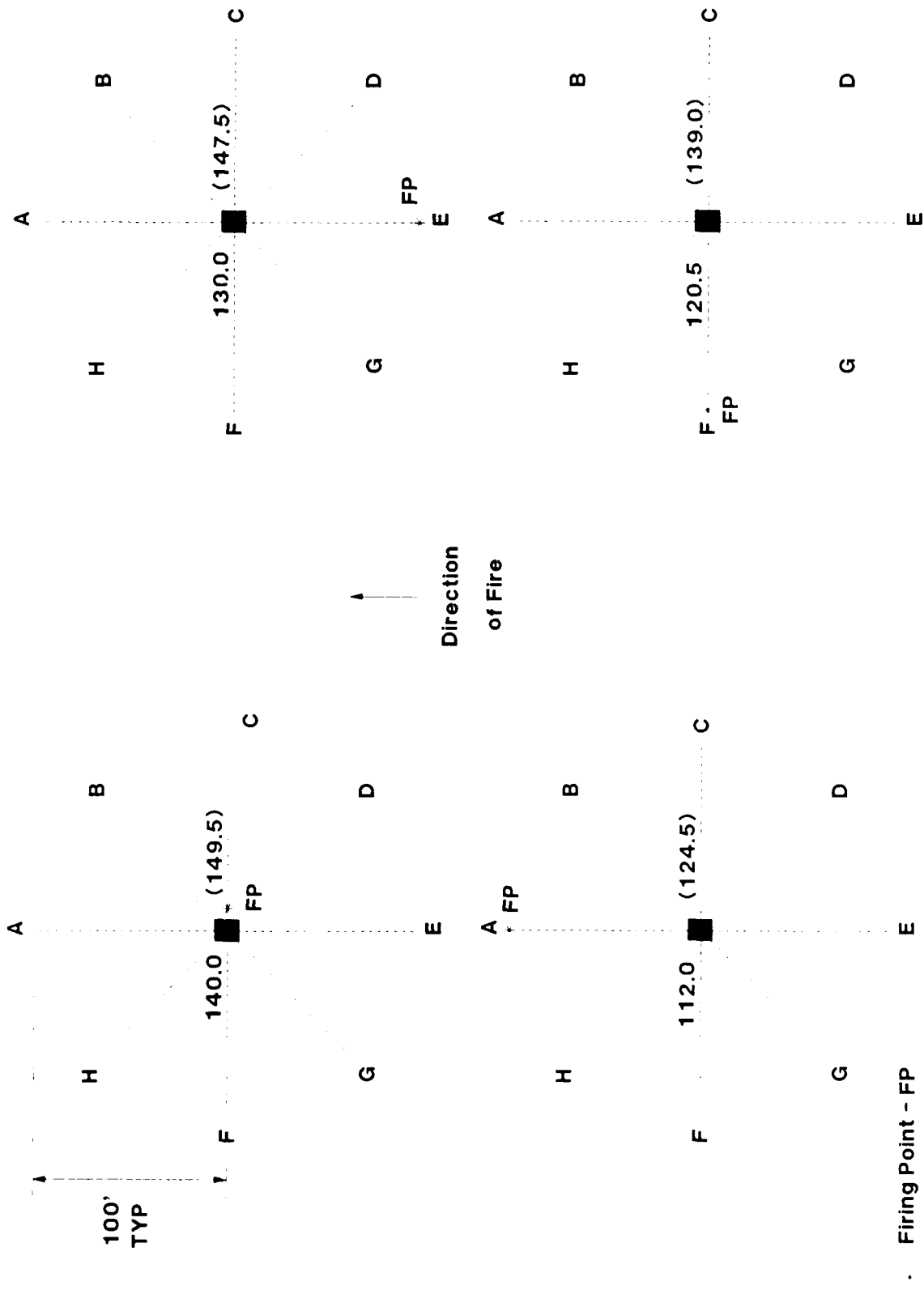

Figure 7. Foam box, 2 in. thick

