

AD-A213 073

Application of a PC Based, Real-Time, Data-Acquisition System in Rotorcraft Wind-Tunnel Testing

Matthew L. Wilbur
Aerostructures Directorate
USAARTA-AVSCOM
Langley Research Center
Hampton, Virginia

NASA

National Aeronautics and
Space Administration
Office of Management
Scientific and Technical
Information Division

1989

The use of trademarks or names of manufacturers in this report is for accurate reporting and does not constitute an official endorsement, either expressed or implied, of such products or manufacturers by the National Aeronautics and Space Administration.

Summary

Data have been acquired for a rotorcraft test in the Langley Transonic Dynamics Tunnel using a desktop data-acquisition system. The system, which consists of an IBM Personal Computer AT (PC-AT) and an Omega Engineering OM-900 stand-alone interface system, is well suited for acquiring high-speed data on a limited number of analog channels. The data-acquisition system and the interrupt-driven software, which provides the capability for near real-time, cyclic data acquisition as well as data storage and display, are described herein.

Introduction

The acquisition of data during research testing often requires sampling many channels at extremely high data rates. Such is the case in large-scale, wind-tunnel testing, for which mainframe computers are generally employed to meet the demanding requirements placed on data acquisition. However, with the increased power and memory of current desktop computer systems, highly accurate measurements can be made on a limited number of channels with much smaller systems. These systems are useful as backups to the larger systems, are portable, and are available for an easily affordable price. One such system has been developed for rotorcraft testing at Langley Research Center. The system has been used successfully both in the Langley Transonic Dynamics Tunnel (TDT) and in a remote facility used exclusively for testing rotors in hover. The system and its use during a rotorcraft test in the TDT are described in this paper.

The data-acquisition system used for the test is an Omega Engineering OM-900 stand-alone interface system in tandem with an IBM PC-AT that acts as a host computer. The system is capable of taking data and displaying it in near real time in both a tabular and graphic format. The data, which include rotor-performance and dynamic-loads measurements, can be stored for later use.

Symbols

- R rotor radius, ft
 V free-stream velocity, ft/sec
 μ rotor advance ratio, $V/\Omega R$
 Ω rotor rotational velocity, rad/sec

Hardware Description

Many vendors supply data-acquisition equipment for use with personal computers. Equipment selection depends largely on the intended uses and portability desired for the data-acquisition system. The

equipment described in this paper was selected for its stand-alone capabilities, acquisition speed, and easily rack-mounted design. However, equipment is available which is completely contained within a PC chassis and therefore offers maximum portability.

The data-acquisition hardware used for this study was the Omega Engineering, Inc. OM-900 series equipment. The OM-900 is a stand-alone, microprocessor-based, data-acquisition and control system which can be configured according to user requirements by selection of appropriate system modules. The system can be accessed by either a "dumb" ASCII terminal or, as for this study, through the use of a host computer system. The modules used include the OM-913 digital input/output (I/O) module and the OM-916 analog input module. A power-supply module and the OM-991 central processing unit (CPU) module are requirements for any OM-900 system and are included for this study.

The OM-991 central processing unit can control up to 15 OM-900 modules. It manages all OM-900 functions and any user communications. It contains an Intel 8088, 16-bit microprocessor that runs at 5 MHz. The CPU is responsible for maintaining all system timing via its real-time clock. Two user-programmable timers are available to manage data acquisition and to control task scheduling. The CPU also maintains all user communications and data transfer with an interrupt-driven RS-232 serial port capable of baud rates from 110 to 19.2K or with optional IEEE-488 or RS-422/485 interfaces. An easy-to-use command structure allows the user access to all OM-900 commands and built-in mathematical routines such as data scaling and statistical quantities.

The OM-913 digital input/output module is equipped with 60 bidirectional I/O channels. Special features of the module allow for 15-digit, binary coded digit (BCD) inputs or up to six frequency counters, event counters, timers, frequency generators, or pulse generators.

The OM-916 analog input module is equipped with 8 analog input channels as well as 8 digital input and 8 digital output channels. Analog input ranges are software-selectable to ± 0.2 V, ± 2.0 V, and ± 20.0 V. The module multiplexes analog input signals to a sample-and-hold circuit which supplies a 12-bit, successive-approximation, analog-to-digital (A/D) converter. Converted samples are stored internally in a 32K buffer or are immediately returned to the user when operating at low data rates. The module allows for both a low- and high-speed analog data-acquisition mode. For the low-speed acquisition mode, the maximum aggregate sampling rate is



Dist	Special
A-1	

<input checked="" type="checkbox"/>
<input type="checkbox"/>
<input type="checkbox"/>
des
or

20 samples per second. For the high-speed acquisition mode, data may be taken at up to 20 000 samples per second for a single channel or up to a maximum aggregate sample rate of 10 000 samples per second for multiple channels. The high-speed mode requires that the module be serviced continually by the OM-991 CPU module; this service disables CPU service to other modules in the system.

Omega Engineering provides other OM-900 system modules that were not used in this study. These include thermocouple, strain-gage, and linear and rotary variable differential transformer (LVDT/RVDT) input modules; analog output modules; and multiplexer modules. Also available are several power-supply modules designed to satisfy different requirements. The OM-901 power-supply module, which provides for up to 40 W of power converted from a 115 or 230 V, ac source, is used for this system. Other power-supply modules can provide up to 60 W from standard ac sources or from 12, 24, or 48 V dc supplies. Reference 1 provides more information on the OM-900 system modules and their uses.

An IBM PC-AT computer operating under IBM Disk Operating System (DOS) version 3.2 acts as the host system for the OM-900 equipment in this data-acquisition application. The computer is equipped with an 8-MHz 80286 CPU, an 80287 math coprocessor, 512K random access memory (RAM), a 1.2-megabyte floppy disk drive, a 30-megabyte hard disk, 2 serial ports, and an enhanced graphics adaptor (EGA) that drives an enhanced color display.

The data-acquisition system, as used for this study, is shown in figure 1. The OM-900 equipment alone is shown in figure 2.

Test Description

The wind-tunnel test was performed with several different rotor-system configurations mounted on the Aeroelastic Rotor Experimental System (ARES). The ARES is used in the TDT for measuring rotor loads and performance, aeromechanical stability, and vibration data. The ARES model and the TDT facility are thoroughly described in reference 2; however, a brief description is included herein.

The TDT, a schematic of which is shown in figure 3, is a continuous-flow tunnel with a slotted test section. The tunnel is capable of operation up to Mach 1.2 at stagnation pressures from 0.1 to 1.0 atm. The test section is 16 ft square with cropped corners and has a cross-sectional area of 248 ft². Either air or refrigerant-12 (R-12) may be used as a test medium. For this study, testing was conducted in R-12 at an approximate density of 0.006 slug/ft³.

The ARES model is shown mounted in the test section of the TDT in figure 4. The ARES is a

generic rotor test bed with a self-contained rotor-control and drive system. The rotor-control system, rotor speed, and the model shaft angle of attack are remotely controlled during testing. Rotor forces and moments are sensed by a six-component, strain-gage balance mounted below the model drive system. Additional instrumentation allows for measurement of rotor blade loads and motion as well as returning rotor-speed and position information.

Data-Acquisition Requirements and System Setup

Rotorcraft testing in the TDT requires demanding data-acquisition techniques such as on-line acquisition, reduction, and real-time display of ARES balance loads, as well as data storage for off-line reduction and plotting. To perform such a function, a minimum of nine channels of data acquisition are necessary. These channels must include input from the six strain-gage-balance channels, the model shaft angle-of-attack sensor, a sensor which provides a pulse once every rotor revolution, and the sensor which provides information on the rotor rotational speed. The wind-tunnel operating parameters such as speed and density must also be calculated in real time from temperature, R-12 purity, and static- and total-pressure readings provided by tunnel instrumentation.

A schematic of the OM-900 data system and its connections to the IBM PC-AT and the ARES model is shown in figure 5. Communication between the OM-900 system and the PC is performed through a 9600-baud RS-232 serial link. This link provides all command and data transfers to and from the OM-900. The first six channels of the OM-916 analog input module were connected to the ARES strain-gage balance. Channel 7 was used to read the model shaft angle of attack from an accelerometer mounted within the ARES. Channel 8 was connected to the model sensor which provided the once-per-revolution pulse. This pulse corresponds to the reference blade passing over the tail of the model and allows azimuthal positioning information for the rotor to be resolved from the data. All input signals to the analog input module were conditioned and amplified by independent amplifiers. The OM-913 digital input/output module was used to measure rotor rotational speed. This was accomplished by connecting one of the frequency counters to the 60-per-revolution sensor on the model. The temperature and static and total pressures of the wind tunnel were supplied to the host PC-AT on demand by an external processor connected through a serial link. The wind-tunnel R-12 purity was supplied to the PC via user interface under program control.

Software

Data acquisition, real-time computations and data plotting, data storage, and user interface are managed by software executed on the IBM PC-AT. The software is written in Microsoft QuickBASIC version 3.0. The software is written in this version of compiled BASIC as opposed to another high-level language for two reasons. First, the QuickBASIC compiler allows for easy implementation of interrupt-driven code; this code is a necessity in a real-time data-acquisition environment. Second, QuickBASIC allows for easy access to high-resolution EGA graphics and allows real-time display of the model data. These advantages allow the use of interrupt-driven code and graphics without resorting to assembly-language programming. The QuickBASIC compiler and its usage are described in reference 3.

The structure used in developing the software is shown in figures 6 to 9. Two main programs and numerous interrupt-service routines are used. One of the main programs (fig. 6) allows the user to specify the format of the real-time output, and the other (fig. 7) provides the actual real-time data acquisition, calculations, data display, and data storage. A variety of interrupt-service routines complete the software set and allow the OM-900 to effectively interface with the PC and provide user control over data-system processes. Two of the most important interrupt-service routines, the communications and data-storage routines, are diagrammed in figures 8 and 9. Each of these routines is discussed in detail in subsequent sections.

The flow diagrams in figures 6 to 9 have been condensed to eliminate the many details necessary to manage a data-acquisition activity of this scope. However, the major functions of the software are addressed in the figures. Functions which are associated with OM-900 communications or data acquisition are generally displayed in their own blocks; in many cases, however, the program statements which they represent are only a few lines long. On the other hand, blocks which are not associated with the use of the OM-900 system often represent hundreds of lines of computer code. The details of these functions are not discussed, because the purpose of this paper is to demonstrate the capabilities and effectiveness of desktop data-acquisition systems such as the OM-900. However, three subroutine listings have been included which demonstrate some basic calculations necessary to set up the data acquisition. These listings also illustrate command structures for the OM-900 data-acquisition system.

Initialization Program

Figure 6 represents the flow for the initialization program. Its primary data-acquisition-system functions are to open communication lines between the PC-AT and the OM-900 and external processors and reset the OM-900 to its power-up condition. However, the program is also responsible for initializing system variables and allowing the user to specify the real-time data which are to be displayed during a wind-tunnel run. For example, it allows the user to specify calibration coefficients for the ARES balance and to specify parameters associated with the rotor system being tested. These values are stored for later use in converting balance voltages to engineering units and calculating rotor-performance coefficients. The program allows the user to specify up to 14 real-time variables which are displayed digitally when the data-acquisition system is active. It also allows the user to set up the real-time plotting capabilities of the system. Up to two plots may be requested and any of 25 system variables for the ordinate or abscissa are selected. Ranges for the axes are interactively specified by the user. Finally, the program manages the transfer to the real-time data-acquisition and display program.

Data-Acquisition and Display Program

During ARES testing, data acquisition takes place nearly continuously. That is, when an actual data point is not being recorded, the model balance, angle of attack, rotor speed, and tunnel conditions are constantly being monitored, reduced, and displayed in near real time. To accomplish this, an interrupt-driven routine was written. Figure 7 is a flow diagram of the routine.

The first action which the program takes is to enable an interrupt on the communication line connected to the OM-900. While this interrupt is enabled, the arrival of any character on the communications port will force an immediate transfer to a communications interrupt-service routine which reads the data from the OM-900. To avoid an inadvertent interrupt, the communications buffer is cleared before the interrupt is enabled. The communications interrupt-service routine is discussed in greater detail subsequently.

Once the communications interrupt has been enabled, program variables are initialized if necessary, and the OM-900 is initialized and activated using the "OM900Set" subroutine shown in appendix A. During OM-900 initialization, the OM-991 CPU module is commanded to delay all data output to the PC by 850 msec, the OM-916 analog input module is set for an analog input range of ± 2.0 V.

and a frequency counter on the OM-913 digital I/O module is commanded to begin counting the 60-per-revolution pulses with a 1-sec gate time. This allows the OM-913 to read the current ARES rotor speed (in rpm) and update it in an internal register once every second. Upon completion of these initialization processes, the OM-900 is actively acquiring and internally updating rotor-speed information. Next, the OM-916 analog input module is commanded to enter the high-speed, data-acquisition mode and take data from the ARES strain-gage-balance and shaft angle-of-attack sensor at 476 samples per second for a time calculated by the "CalcSamp" subroutine shown in appendix B. The time is calculated for five rotor revolutions, based on the most recent rotor rotational speed available from the OM-913. If the rotor speed is below 300 rpm (650 to 780 rpm is nominal), the system considers the rotor to be nonrotating, and the module is instead commanded to take data for 375 msec. Once acquired, these data are averaged and the results are returned to the PC after the requested 850-msec gate-time delay. The gate-time delay is necessary because the CPU module stops sending timing signals to all system modules except the analog input module during high-speed analog data acquisition. The associated interruption in timing signals temporarily resets the ARES rotor-speed register on the digital I/O module to zero. The specified gate-time delay allows the module to resume frequency-counting operations long enough for the ARES rotor speed to be refreshed before the next interrogation by the PC.

While the OM-900 is actively acquiring and manipulating data, the PC is free to continue with other system functions. However, the OM-900 is able to interrupt PC processing at any time through the communications interrupt. Once the OM-900 is activated, the display on the PC is created. This process includes setting the screen for high-resolution graphics, loading in a library of alpha-numeric graphics characters, drawing the axes for the first plot (if plots are requested), building the tabular variable display, setting up the function-button interrupts, and writing the command menu on the bottom of the screen.

At this point, the program enters a continuous loop as shown in figure 7. This loop is responsible for continually updating the current values of wind-tunnel pressures and temperature, and reducing these to usable values for density, velocity, Mach number, and dynamic pressure. Upon completion of tunnel parameter calculations, the program begins reducing the most recent ARES data received from the OM-900 to engineering units. To accomplish this reduction, the routine accesses a variable array which contains the most recent mean voltages

acquired from the ARES balance and angle-of-attack sensor; the routine also uses the most recent value of rotor rpm.

The engineering-units conversion subroutine first enters a loop to calculate the appropriate engineering units for each balance-channel mean value. These values are computed based on the calibration coefficients entered by the user when executing the initialization program. The values are then corrected for any zero offset and adjusted for interactions between individual balance channels. Tare corrections associated with the ARES are then applied. Reduced balance-channel data are then resolved into wind-axis components (i.e., lift and drag) and are nondimensionalized into rotor-performance coefficients. The reduced balance-channel data, rotor-performance coefficients, rotor-speed and attitude information, and wind-tunnel parameters are stored in a common variable array for access by other program routines.

Upon return from the engineering-units subroutine, the program makes the necessary updates to the real-time variables and any plot displayed on the screen. The routine then loops to obtain new tunnel parameters as shown in figure 7. The loop is generally executed 3 to 4 times per second and allows the user to view the most recently available data in a near real-time environment.

Once the program reaches the continuous loop shown in figure 7, the only way to modify the program actions are through interrupts and their associated service routines. The interrupt-service routines allow for crucial system functions, such as data transfer, and provide user control over the system as a whole. Two of these interrupt-service routines are diagrammed in figures 8 and 9 and are discussed in the following sections.

Communications interrupt-service routine. One of the most crucial interrupt-service routines is the communications interrupt. It is called "ReadData" and is shown in appendix C. Once enabled, this interrupt is activated each time incoming OM-900 data arrive on the PC serial I/O port. Therefore, this routine reads the mean ARES balance voltages and shaft angle of attack as returned by the OM-900. It then requests that the current value of rotor rpm stored in the OM-913 module be returned immediately. All these values are stored in variables for use in data reduction in the engineering-units conversion routine. Finally, the routine requests that the OM-900 take five more revolutions of balance and angle-of-attack data, average it, and return it to the PC after the 850-msec gate-time delay. This action effectively completes the cyclic data-acquisition loop and thereby provides the PC with completely new

ARES data nominally every 1 to 1.3 sec, depending on rotor speed. Upon completion of the communications interrupt-service routine, control is returned to the process that was being executed immediately prior to the interrupt.

Data-storage interrupt-service routine. The interrupt-service routine which allows data to be acquired and subsequently stored on the PC is shown in figure 9 and is referred to as the data-storage routine. The routine is initiated through an interrupt connected to a function key on the PC. Therefore, the user may execute the data-storage routine at any time by striking the appropriate function key. The routine initially disables the communications interrupt, so that the cyclically updated data acquisition is inhibited. The data-storage interrupt itself is then disabled to ensure that the routine is not inadvertently reexecuted during processing. The command and data buffer on the OM-900 is then cleared to eliminate old command and data transfers between the PC and the OM-900. Sample rates and acquisition times are calculated based on user selectable values for the number of rotor revolutions required, the number of samples required per revolution, and the most recent value for rotor rpm obtained from the internal register on the OM-913. The OM-900 is commanded to acquire the data as per user request, and the mean values for balance channels and angle of attack are returned to the PC. These data are reduced using the engineering-units conversion subroutine; the data are displayed digitally and on the plots, and symbols are used to distinguish data points. The data are stored in a file on the PC hard disk, along with rotor rpm, wind-tunnel parameters, and point identification. If time-history data are requested by the user, the mean data are followed by a stream of data representing the waveforms from the strain-gage-balance, the angle-of-attack, and the once-per-revolution channels. These data are stored in a voltage format on a separate hard-disk file, along with values that identify the data point, number of samples, and sampling-frequency information. Upon completion of data storage, the routine supplies the commands to the OM-900 to resume the cyclic data acquisition and enables both the communications and data-storage interrupts. Control then returns to the interrupted process.

Other interrupt-service routines. The other interrupt-service routines used with the system are designed to allow for the user interface and control over the data acquisition and display. The interrupts are typically assigned to PC function buttons which are keyed to a two-line menu system at the bottom

of the display. When using the menu, the user can specify sampling rates, clear plots, change plot symbols, exchange plots, change the R-12 purity used in tunnel parameter calculations, activate the data-storage routine, and access a variety of other test-specific routines. The menus also provide the user with an interface to the initialization program in order to request changes to the real-time display values and plots.

Results

The OM-900/PC-AT data-acquisition system affords a convenient, reliable, and accurate method of acquiring data for the limited number of channels necessary for this test. Typically, a completely new set of near real-time data is displayed on the screen every 1 to 1.3 sec. Up to two plots can be viewed by the user, one at a time, which provides a continuous graphical display of user-selected, real-time variables. Figure 10 shows a typical display used during the ARES testing. Data acquisition and storage of data points took approximately 15 sec when only mean balance data were stored and up to 2 min when dynamic data were stored, depending upon the requested sampling rates and the number of rotor revolutions. The data collected were processed and plotted off-line for further engineering analysis.

Examples of the data obtained using the data-acquisition system are shown in figures 11 and 12. Figure 11 contains reduced ARES performance data. The plot shown is nondimensional rotor lift plotted against nondimensional rotor torque required for a specific forward-flight velocity. An example of the time-history data resolution attainable with the OM-900 is shown in figure 12. The figure shows 5 revolutions of data from the ARES balance normal-force channel. The data were taken at a sampling rate of 1250 samples per second for the six balance channels, the shaft angle-of-attack channel, and the once-per-revolution channel. As shown, the frequency resolution is quite good and is more than adequate for this type of rotorcraft testing, for which frequencies higher than 120 Hz are of little interest.

Conclusions

Data have been acquired for a rotorcraft test in the Langley Transonic Dynamics Tunnel using a desktop data-acquisition system. The system, which consists of an IBM PC-AT and an Omega Engineering OM-900 stand-alone interface system, is well suited for acquiring high-speed data on a limited number of analog channels. Based on the information obtained during this research effort, the following conclusions have been reached:

1. The OM-900 operating in tandem with a personal computer is capable of acquiring and storing relatively high-frequency data accurately, efficiently, and at a reasonable cost.

2. Interrupt-level programming can be effectively implemented with the data-acquisition system to increase its power and flexibility by allowing for both real-time processing and data storage.

3. QuickBASIC is an effective tool for the data-acquisition-system programming. It provides for access to keyboard and communications interrupts, as well as high-resolution graphics, without resorting to assembly-language programming.

NASA Langley Research Center
Hampton, VA 23665-5225
May 11, 1989

Appendix A

OM900Set: OM-900 setup routine

```
SUB OM900Set (NumSampRT) STATIC

rem      GENERAL NOTES: Device #1 in PRINT and INPUT statements
rem      provides communications with the OM-900 throughout the
rem      listings.

rem      Command OM-991 CPU to delay all communications to the
rem      host PC by the 850 msec gate time.

PRINT #1. "@EOLDelay=850"

rem      Command OM-916 Analog Input module to enter the ±2.0
rem      Volt range mode.

PRINT #1. "#1. VIR=-3"

rem      Activate a frequency counter on the OM-913 Digital Input/
rem      Output module to begin acquiring rotor RPM.

PRINT #1. "#3. FREQ14=ON(0)"

rem      Command OM-916 Analog Input module to acquire data from
rem      the shaft angle transducer and 6 balance channels at a
rem      rate of 476 samples per second for NumSampRT samples.
rem      The Nth=3 sub-command tells the module to accept only
rem      every third sample.
rem
rem      Sample Rate = Max. Sample Rate / # channels / Nth
rem                  = 10000 / 7 / 3
rem                  = 476.2

PRINT #1. "#1. BVIN[": NumSampRT: "] 1.2.3.4.5.6.7:NTH=3"

rem      Command OM-916 to return mean voltages for the channels
rem      after data acquisition is complete. Return to calling
rem      routine.

PRINT #1. "#1. BVMEAN 1.2.3.4.5.6.7"

END SUB
```

Appendix B

CalcSamp: real-time data sample calculation

SUB CalcSamp STATIC

rem Calculate the maximum real-time sample rate based on the
rem number of channels being acquired. For real-time
rem sampling, the number of channels (NumChans) is 7.

rem NOTE: RT in variable names refers to Real-Time.

MaxRTRate = 10000.0 / NumChans

rem Calculate the sample time required for NumRevsRT rotor
rem revolutions of data to be acquired.

TimeOneRev = 60.0 / RPM

SampTimeRT = NumRevsRT * TimeOneRev

rem Calculate the number of samples required to obtain the
rem data at a sample rate of 476 samples per second. The
rem quantity (SampTimeRT * MaxRTRate) is divided by 3
rem since the OM-916 module is commanded to retain only
rem every third sample (see appendixes A and C).

NumSampRT = INT((SampTimeRT * MaxRTRate) / 3)

rem If the rotor rotational speed is less than 300 RPM, set
rem NumSampRT to acquire 375 msec of data. Return to
rem calling routine.

IF RPM < 300.0 THEN NumSampRT = INT((0.375 * MaxRTRate) / 3)

END SUB

Appendix C

ReadData: real-time data return routine

ReadData:

```
rem      Queue data acquisition interrupt and disable communications
rem      interrupt.

      KEY(1) STOP
      COM(1) OFF

rem      Read the number of samples acquired and the mean voltages
rem      from the shaft angle transducer and the 6 balance
rem      channels.

      INPUT #1. N. F(1). F(2). F(3). F(4). F(5). F(6). F(7)

rem      Command OM-991 CPU to return rotor RPM immediately. then
rem      reset to delayed communications.

      PRINT #1. "@EOLDelay=0"
      PRINT #1. "#3. Freq14"
      INPUT #1. RPM
      IF RPM = 0. THEN RPM = 0.1
      PRINT #1. "@EOLDelay=850"

rem      Check for overflow conditions on 6 balance channels.

      FOR I = 1 TO 6
          IF ABS(F(I)) > 1.98 THEN LOCATE 21.1
          PRINT "Channel": I: "overflow.":
      NEXT I

rem      Command OM-916 Analog Input module to acquire data from
rem      the shaft angle transducer and 6 balance channels at
rem      a rate of 476 samples per second for NumSampRT
rem      samples. See appendix A for explanation of the Nth=3
rem      sub-command.

      PRINT #1. "#1. BVIn[": NumSampRT: "] 1.2.3.4.5.6.7:Nth=3"

rem      Command OM-916 to return mean voltages for the channels
rem      after data acquisition is complete.

      PRINT #1. "#1. BVMean 1.2.3.4.5.6.7"

rem      Re-activate communications interrupt and data acquisition
rem      interrupt. Return to calling routine.

      COM(1) ON
      KEY(1) ON

      RETURN
```

References

1. *Complete Data Acquisition and Computer Interface Handbook and Encyclopedia, Volume 1.* Omega Engineering, Inc., c.1987.
2. Mantay, Wayne R.; Yeager, William T., Jr.; Hamouda, M-Nabil; Cramer, Robert G., Jr.; and Langston, Chester W.: *Aeroelastic Model Helicopter Rotor Testing in the Langley TDT.* NASA TM-86440. USAAVSCOM TM 85-B-5, 1985.
3. *Microsoft® QuickBasic Compiler for IBM® Personal Computers and Compatibles.* Microsoft Corp., c.1986.



Figure 1. Data-acquisition system.

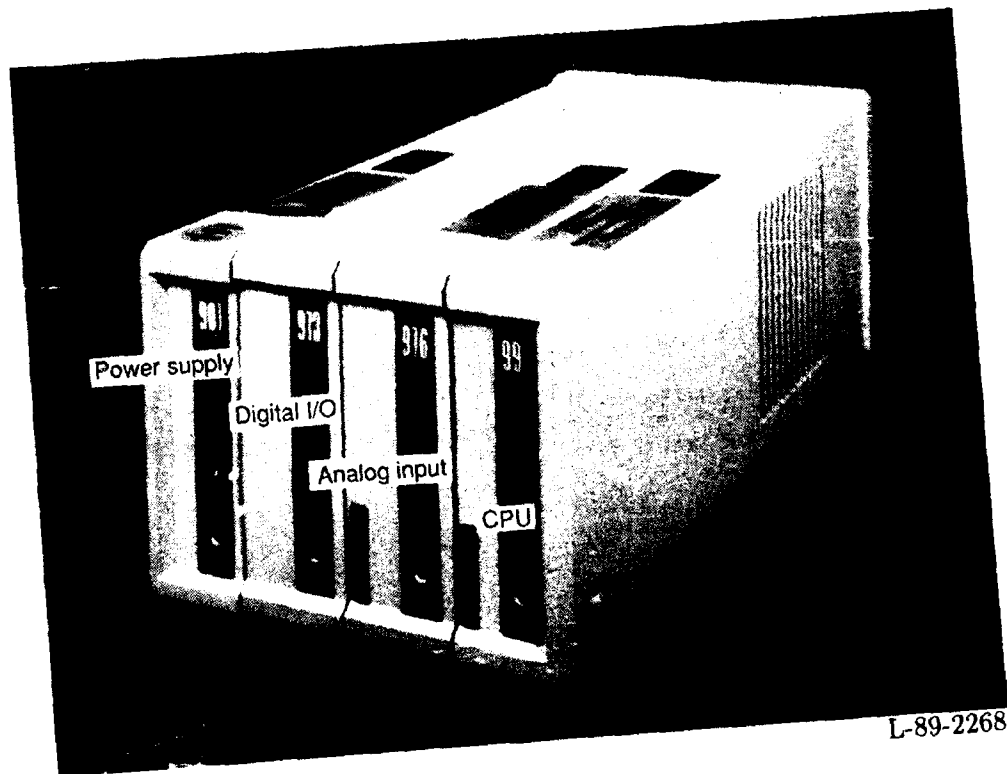
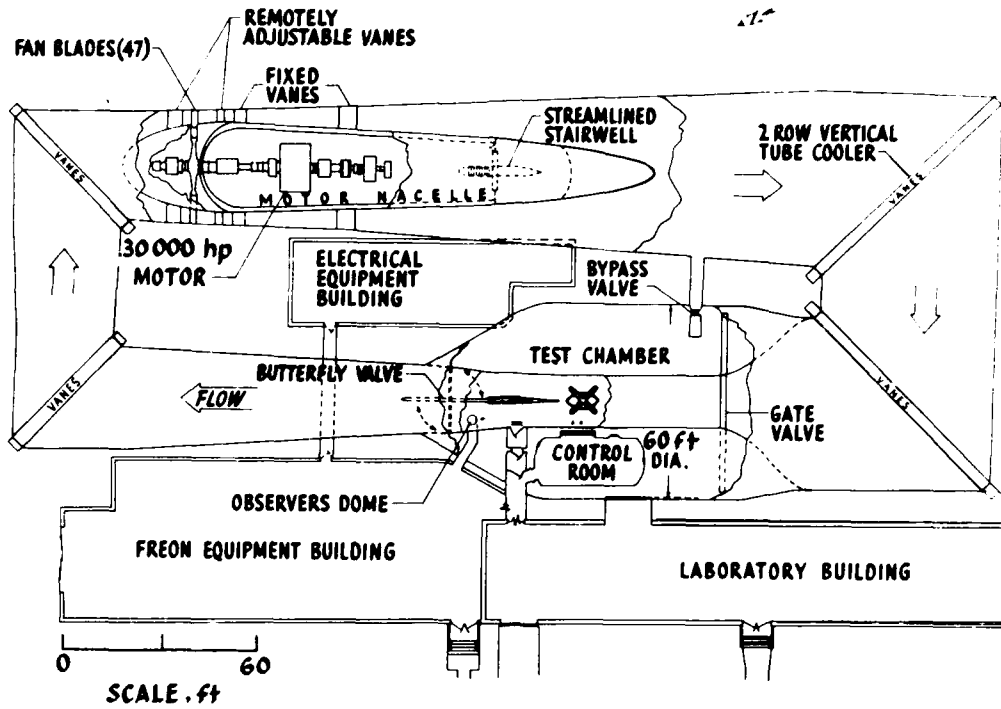
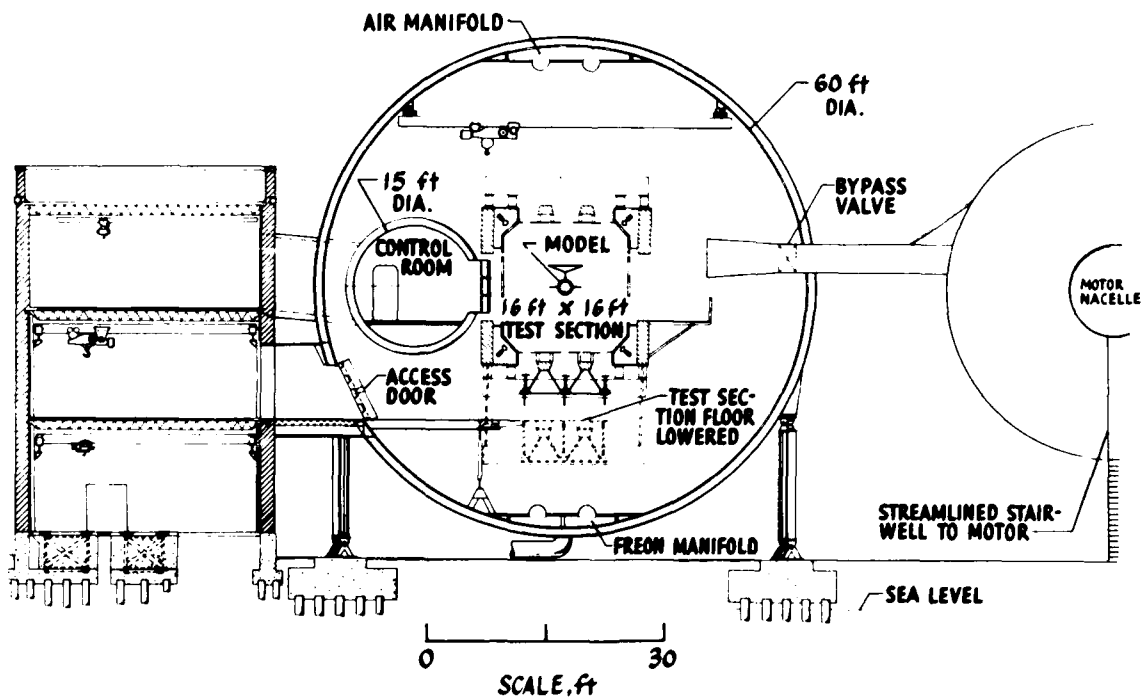

Figure 2. Omega OM-900 data-acquisition equipment.



(a) Tunnel platform.



(b) Tunnel cross section.

Figure 3. Langley Transonic Dynamics Tunnel.

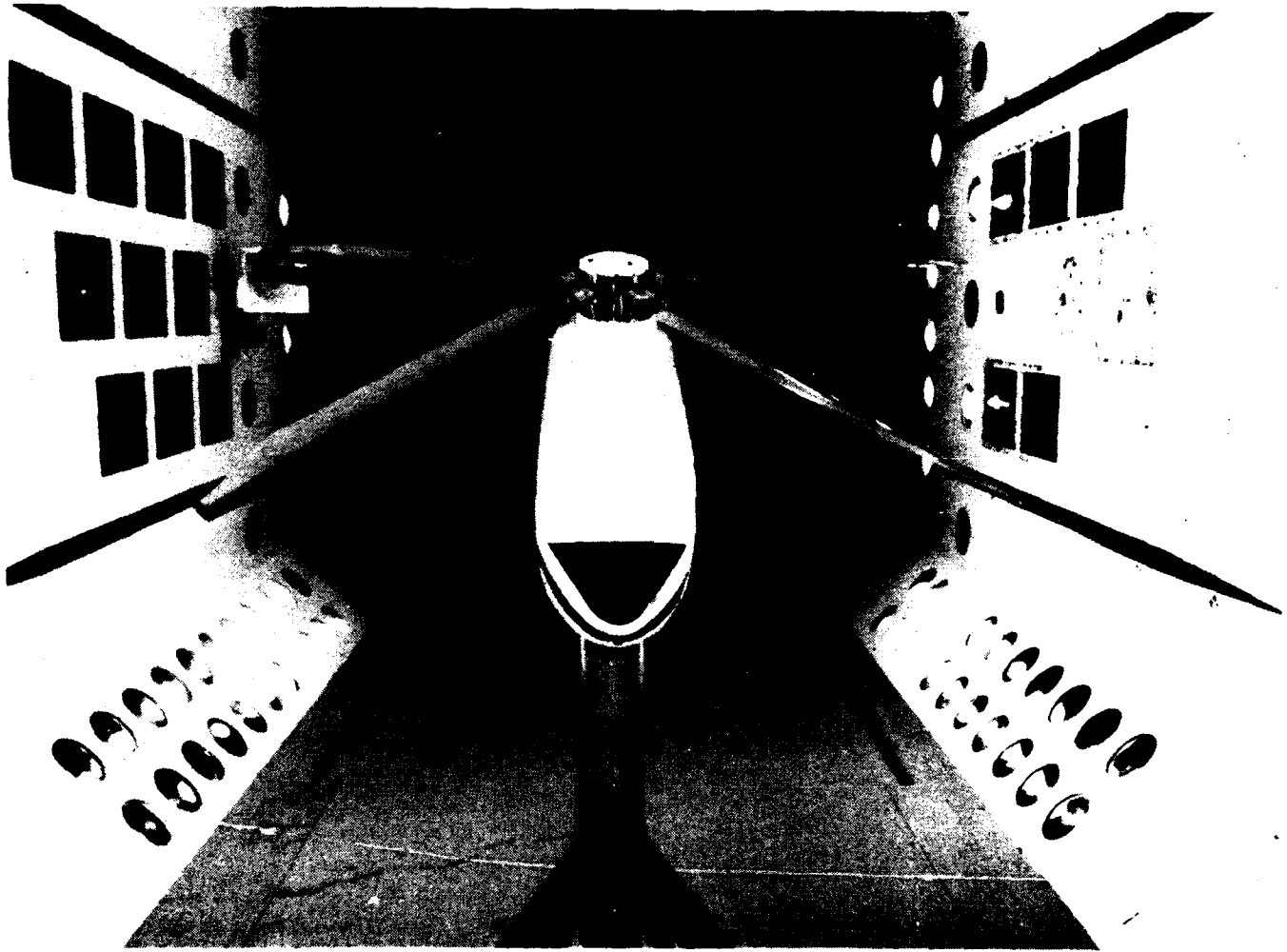

L-85-12,990

Figure 4. Aeroelastic rotor experimental system model in Langley Transonic Dynamics Tunnel.

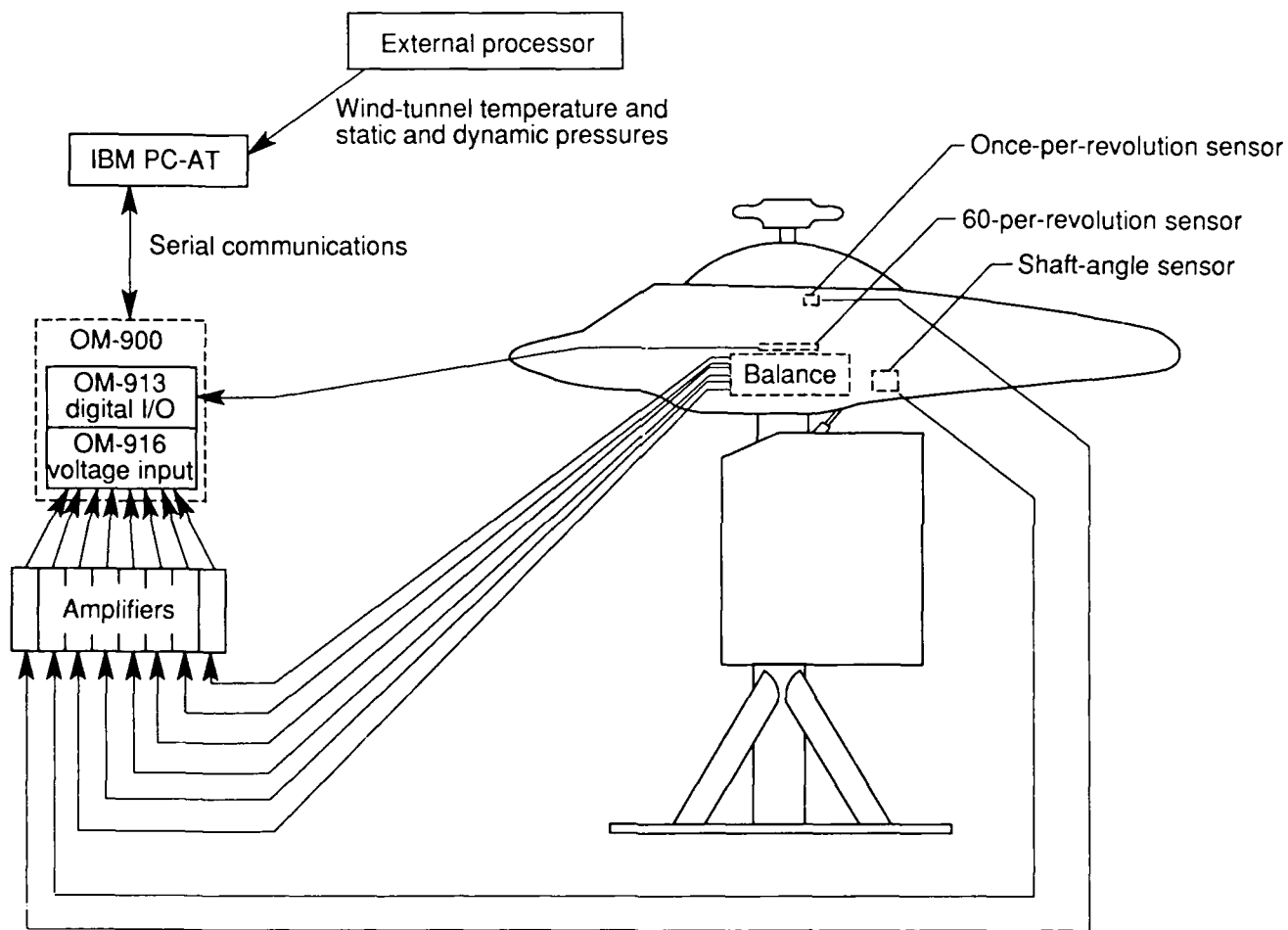

Figure 5. Data-acquisition-system setup.

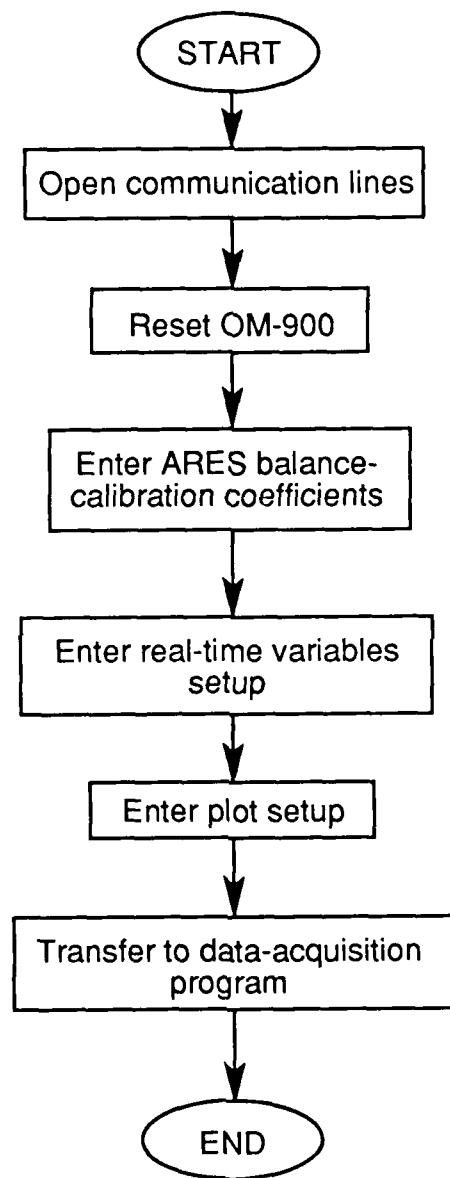

Figure 6. Initialization program.

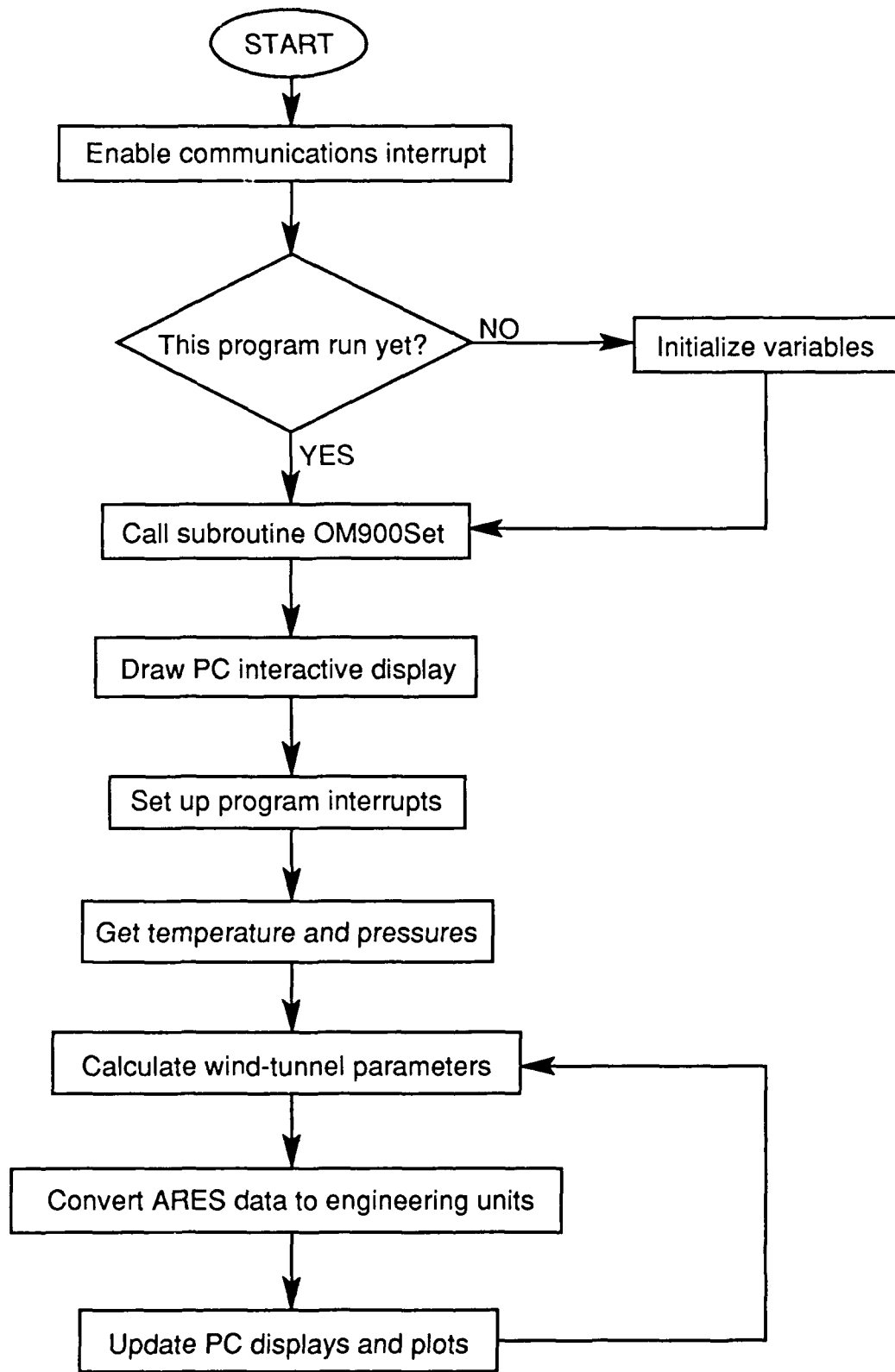

Figure 7. Real-time data-acquisition and display program.

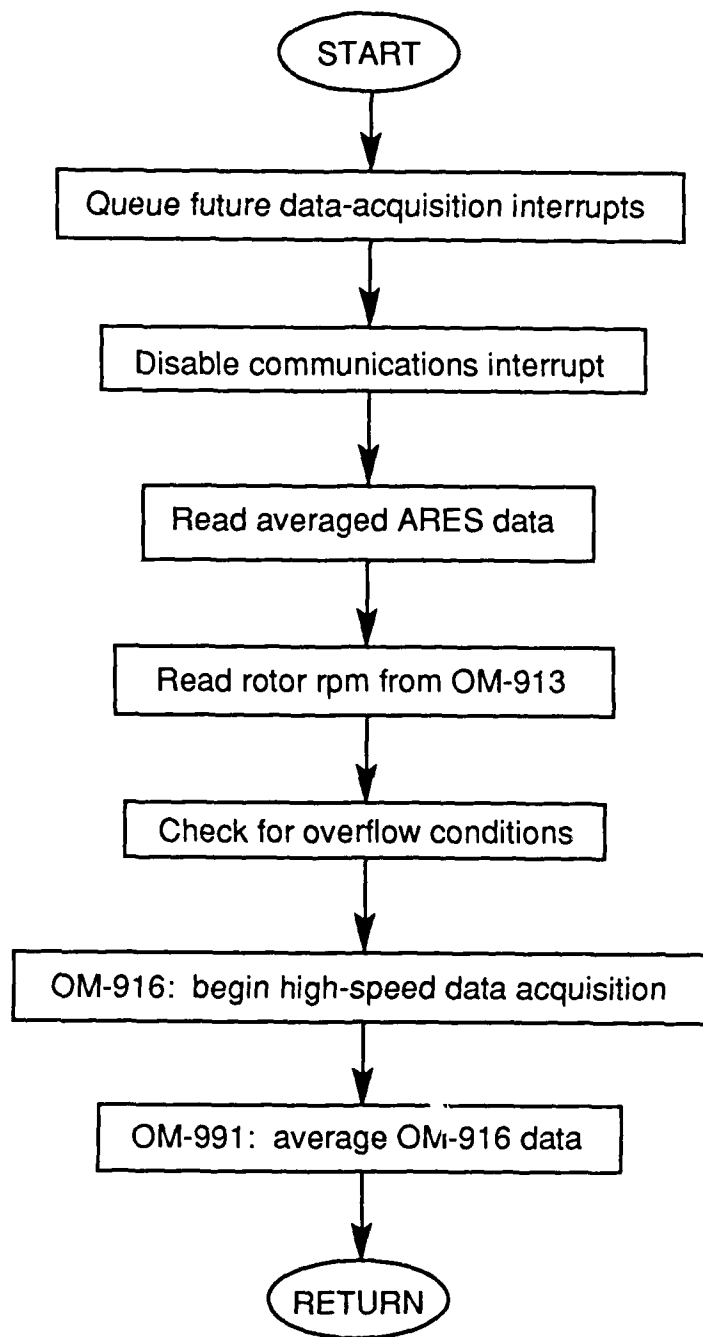

Figure 8. Communications interrupt-service routine.

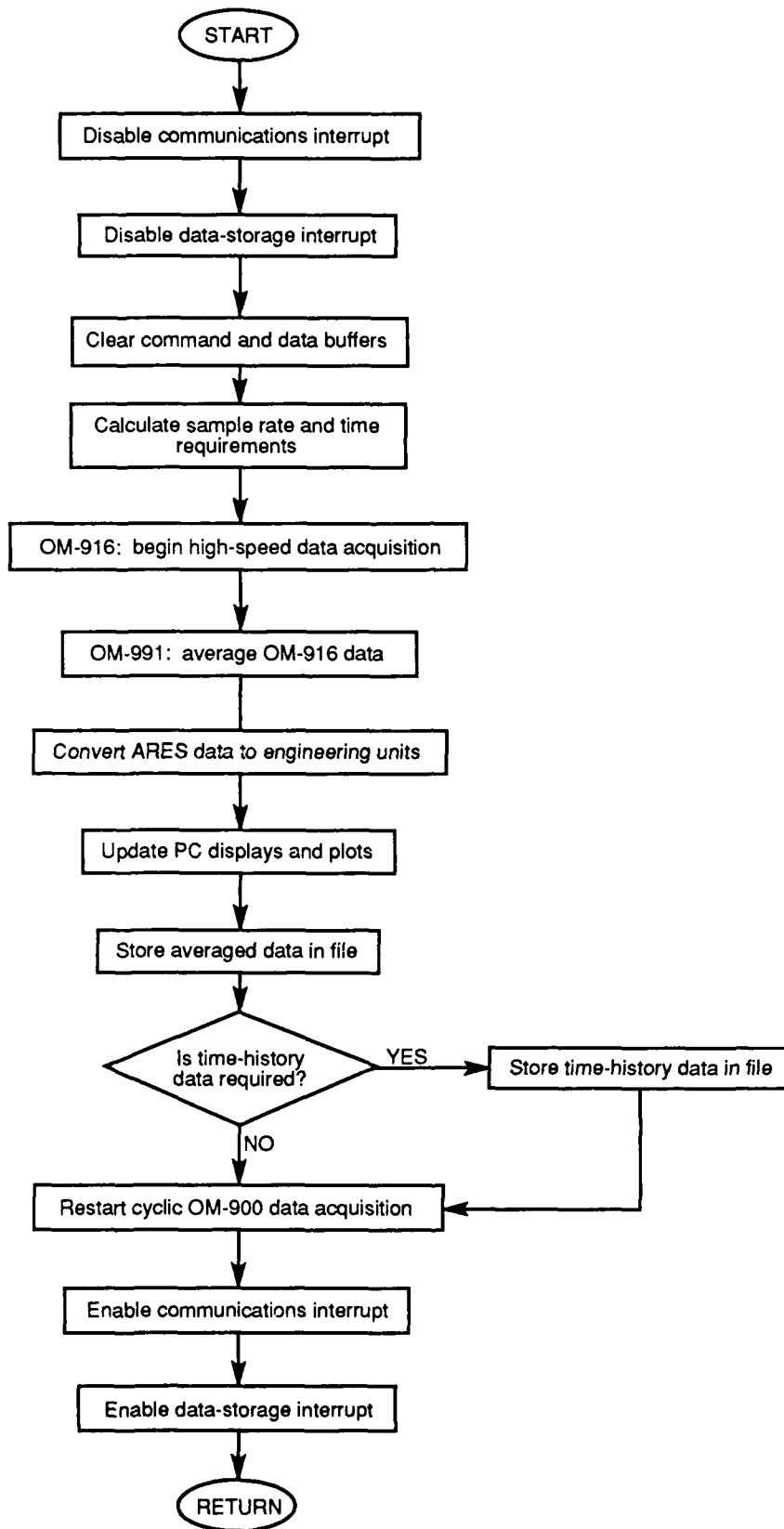

Figure 9. Data-storage interrupt-service routine.

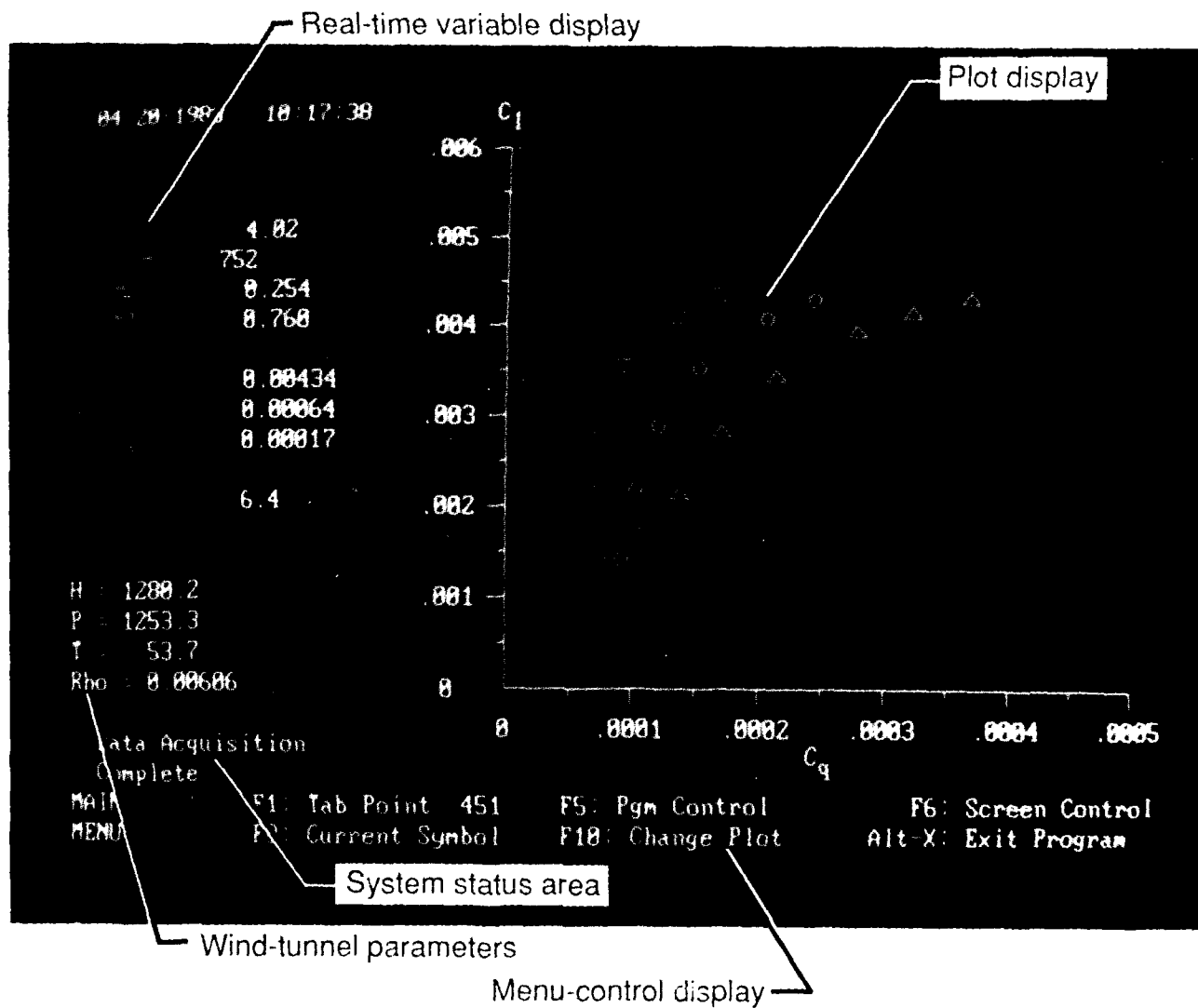

Figure 10. Sample PC interactive display.

L-89-2264

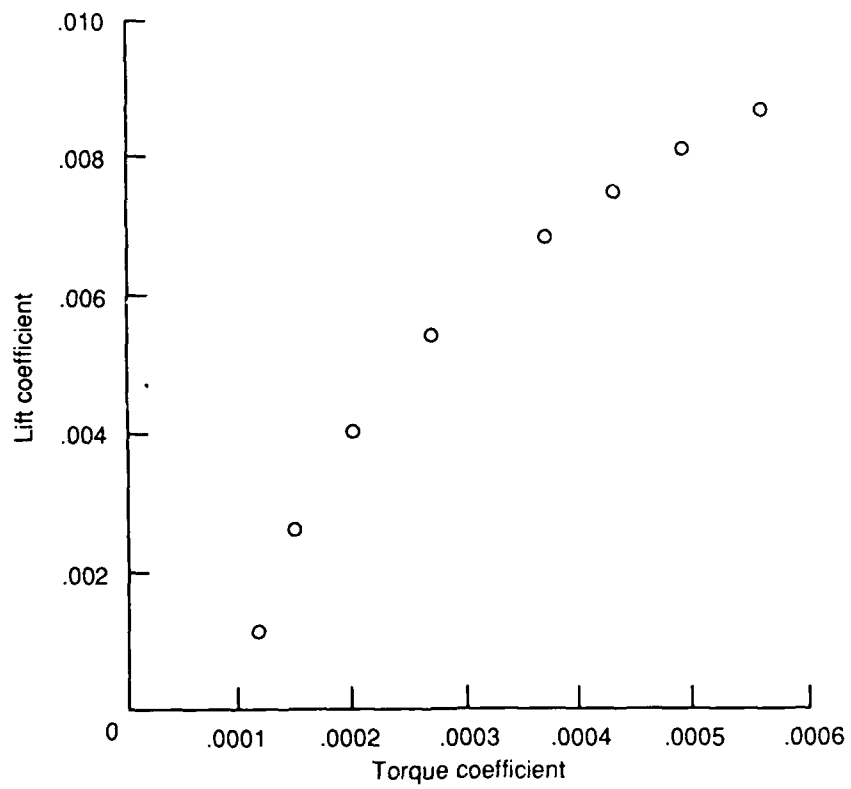

Figure 11. ARES rotor-performance data. $V = 48.5$ ft/sec ($\mu = 0.15$).

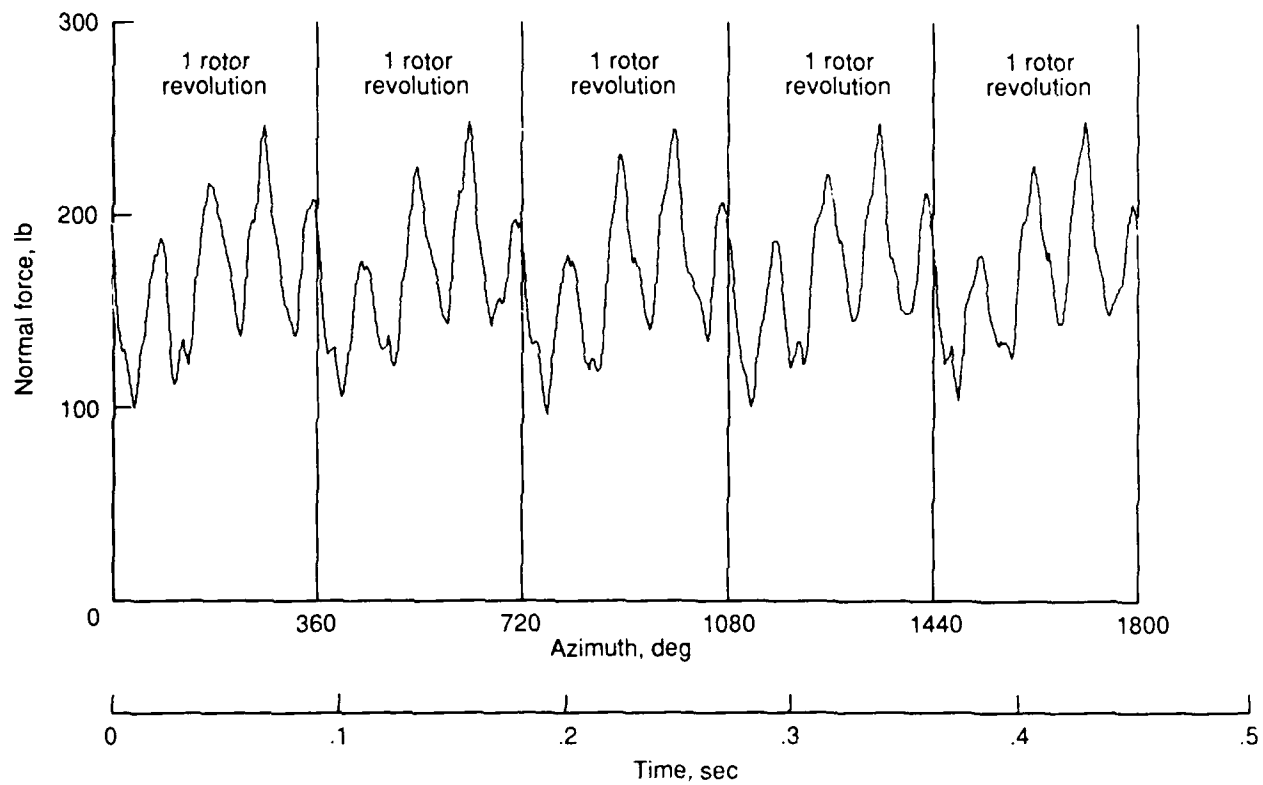

Figure 12. ARES time-history data.



Report Documentation Page

1. Report No. NASA TM-4119 AVSCOM TM-89-B-003		2. Government Accession No.		3. Recipient's Catalog No.	
4. Title and Subtitle Application of a PC Based, Real-Time, Data-Acquisition System in Rotorcraft Wind-Tunnel Testing			5. Report Date July 1989		
			6. Performing Organization Code		
7. Author(s) Matthew L. Wilbur			8. Performing Organization Report No. L-16565		
			9. Performing Organization Name and Address Aerostructures Directorate USAARTA-AVSCOM Langley Research Center Hampton, VA 23665-5225		
12. Sponsoring Agency Name and Address National Aeronautics and Space Administration Washington, DC 20546-0001 and U.S. Army Aviation Systems Command St. Louis, MO 63120-1798			10. Work Unit No. 505-63-51-03		
			11. Contract or Grant No.		
15. Supplementary Notes Matthew L. Wilbur: Aerostructures Directorate, USAARTA-AVSCOM, Hampton, Virginia.			13. Type of Report and Period Covered Technical Memorandum		
			14. Army Project No. 505615964		
16. Abstract Data have been acquired for a rotorcraft test in the Langley Transonic Dynamics Tunnel using a desktop data-acquisition system. The system, which consists of an IBM Personal Computer AT (PC-AT) and an Omega Engineering OM-900 stand-alone interface system, is well suited for acquiring high-speed data on a limited number of channels. The data-acquisition system and the interrupt-driven software, which provides the capability for near real-time, cyclic data acquisition as well as data storage and display, are described herein.					
17. Key Words (Suggested by Authors(s)) Data-acquisition systems Personal computers Helicopters Model rotor testing			18. Distribution Statement Unclassified Unlimited Subject Category 62		
19. Security Classif. (of this report) Unclassified		20. Security Classif. (of this page) Unclassified		21. No. of Pages 22	22. Price A03