

Naval Research Laboratory

Washington, DC 20375-5000

2



NRL Report 9226

AD-A213 134

DTIC FILE COPY

# A Review of Laser Filter Materials

JEANNE A. WELCH

*Applied Optics Branch  
Optical Sciences Division*

September 26, 1989

DTIC  
ELECTE  
OCT 0 5 1989  
S D & D

Approved for public release; distribution unlimited.

89 10 4 055

**REPORT DOCUMENTATION PAGE**

1a REPORT SECURITY CLASSIFICATION <b>UNCLASSIFIED</b>		1b RESTRICTIVE MARKINGS	
2a SECURITY CLASSIFICATION AUTHORITY		3 DISTRIBUTION AVAILABILITY OF REPORT <b>Approved for public release; distribution unlimited.</b>	
2b DECLASSIFICATION/DOWNGRADING SCHEDULE		5 MONITORING ORGANIZATION REPORT NUMBER(S)	
4 PERFORMING ORGANIZATION REPORT NUMBER(S) <b>NRL Report 9226</b>		7a NAME OF MONITORING ORGANIZATION	
6a NAME OF PERFORMING ORGANIZATION <b>Naval Research Laboratory</b>	6b OFFICE SYMBOL (if applicable) <b>6530</b>	7b ADDRESS (City, State, and ZIP Code)	
6c ADDRESS (City, State, and ZIP Code) <b>Washington, DC 20375-5000</b>		9 PROCUREMENT INSTRUMENT IDENTIFICATION NUMBER	
8a NAME OF FUNDING/SPONSORING ORGANIZATION <b>Naval Air Systems Command</b>	8b OFFICE SYMBOL (if applicable) <b>Air 51646</b>	10 SOURCE OF FUNDING NUMBERS	
6c ADDRESS (City, State, and ZIP Code) <b>Washington, DC 20361</b>		PROGRAM ELEMENT NO <b>63262N</b>	PROJECT NO
		TASK NO <b>W0591</b>	WORK UNIT ACCESSION NO
11 TITLE (Include Security Classification) <b>A Review of Laser Filter Materials</b>			
12 PERSONAL AUTHOR(S) <b>Welch, J. A.</b>			
13a TYPE OF REPORT <b>Final</b>	13b TIME COVERED FROM <b>10/87</b> TO <b>9/88</b>	14 DATE OF REPORT (Year, Month, Day) <b>1989 September 26</b>	15 PAGE COUNT <b>28</b>
16 SUPPLEMENTARY NOTATION			
17 COSATI CODES		18 SUBJECT TERMS (Continue on reverse if necessary and identify by block number)	
FIELD	GROUP	Dye-impregnated poly carbonates      Color glasses	
		Interference filters                      Power limiters	
		(Continues)	
19 ABSTRACT (Continue on reverse if necessary and identify by block number)			
<p>This report presents a discussion of laser eye-protection filtering materials. Four classes of filters are evaluated for immediate and future filtering capabilities. Salient features required for near-term multiwavelength filtering are discussed in general, and the effectiveness of several filter materials as laser protection is assessed. Spectral illuminances for the most promising eye-protection filters are computed for representative day- and night-lighting conditions to approximate visual acuity.</p>			
20 DISTRIBUTION/AVAILABILITY OF ABSTRACT <input checked="" type="checkbox"/> UNCLASSIFIED/UNLIMITED <input type="checkbox"/> SAME AS RPT <input type="checkbox"/> DTIC USERS		21 ABSTRACT SECURITY CLASSIFICATION <b>UNCLASSIFIED</b>	
22a NAME OF RESPONSIBLE INDIVIDUAL <b>J. A. Welch</b>		22b TELEPHONE (Include Area Code) <b>(202) 767-3005</b>	22c OFFICE SYMBOL <b>Code 6532</b>

**18. SUBJECT TERMS (Continued)**

Illuminance	Visual acuity
Luminous transmittance	Multiwavelength
Laser eye protection	

## CONTENTS

INTRODUCTION .....	1
THE THREAT AND EYE DAMAGE .....	1
LASER EYE PROTECTION .....	3
LEP FILTER MATERIALS .....	3
LEP EFFECTIVENESS .....	12
CONCLUSIONS .....	13
REFERENCES .....	18
APPENDIX A — Experimental Optics and Electronics .....	19
APPENDIX B — Electro-Optics Assessment Facility .....	21

Accession For	
NTIS CRA&I	<input checked="" type="checkbox"/>
DTIC TAB	<input type="checkbox"/>
Unannounced	<input type="checkbox"/>
Justification: _____	
By _____	
Distribution/ _____	
Availability Codes	
Dist	Avail and/or Special
A-1	

## A REVIEW OF LASER FILTER MATERIALS

### INTRODUCTION

Because of the growing number of lasers on the modern battlefield, efforts to protect sensors and personnel from laser threats are of prime concern to the defense establishment. Both immediate and long-term protection are sought. Near-term protection seeks to harden against existing deployed threats, while long-term solutions will protect against emerging threats.

The scope of this report is to assess the effectiveness of several filters as near-term laser eye protection and to examine the effects on visual acuity. The effectiveness of general classes of filter materials for long-term protection is also evaluated.

### THE THREAT AND EYE DAMAGE

The most common laser threats on the battlefield are the laser range finder and the laser target designator. The oldest range finders employ ruby lasers, while newer model range finders and most designators employ neodymium: (YAG and glass) or CO<sub>2</sub> technology. These military laser applications benefit from using covert (invisible) lasers. In contrast to most coherent radiation, CO<sub>2</sub> laser light (8 to 10  $\mu\text{m}$ ) does not pose a direct threat to the eye for two reasons: the threshold for damage in the far-infrared is high, and the far-infrared is not transparent to most glasses and plastics.

Several other mature laser technologies exist but are not commonly employed in military systems. These include argon ion and krypton ion continuous-wave (CW), and doubled-Nd:YAG pulsed systems in the visible spectrum, and excimer and tripled-Nd:YAG pulsed systems in the ultraviolet spectrum. Ultraviolet lasers, although covert, are not generally employed because they are easily blocked by clear glass materials and by most plastics. Continuous-wave lasers generally are not used in designating and ranging applications where short bursts of laser radiation are preferred.

Future deployment may be expected for the copper vapor laser in the blue-green and the tunable Alexandrite laser in the near-infrared. Ideally, near-term hardening efforts should include these lasers. Figure 1 summarizes the threat wavelengths.

Finally, wavelength tunability such as that available with vibronic lasers in the near-infrared or from Raman-shifted laser radiation poses a significant spectrum-wide threat. This agility introduces a severe filtering challenge that could require total spectral hardening.

The entire discussion of laser vision hardening can be applied to any sensor system, but only the eye is discussed in detail here. For the spectral response of the eye see Fig. 2. This discussion of laser eye protection (LEP) deals with the unaided eye. The presence of magnifying optics will decrease viewing thresholds by the magnification factor squared [1].

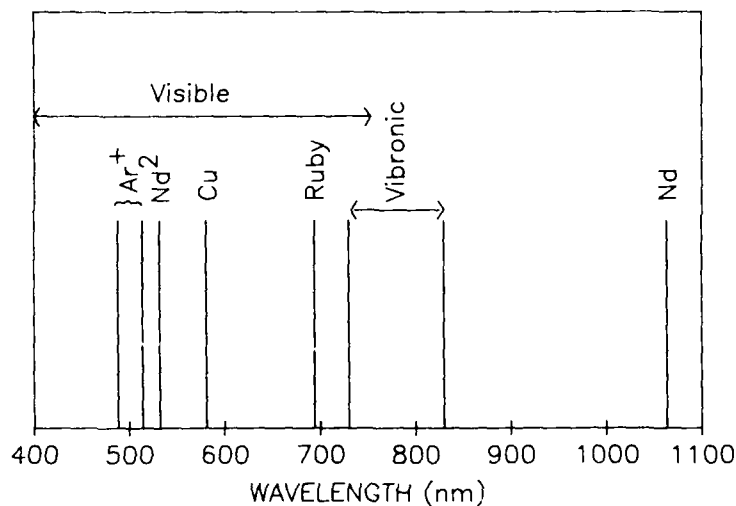

Fig. 1 - Laser threat schematic

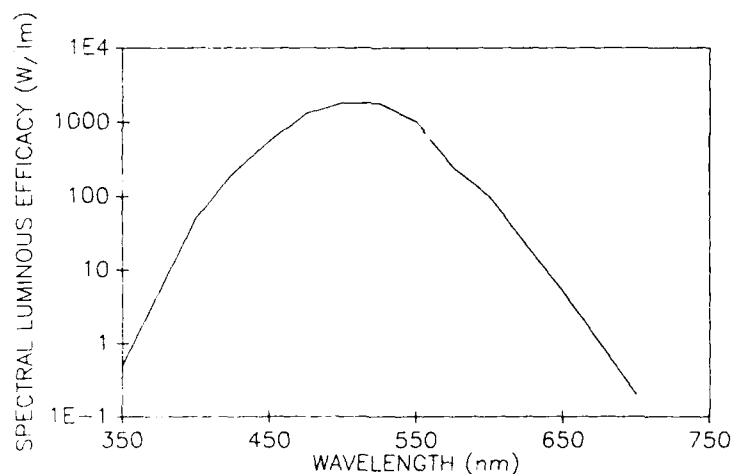

Fig. 2 - Spectral response of the human eye: scotopic (as indicated by — solid line), and photopic\* (as indicated by .... dots) [6]

Although laser systems deployed to date are not designed specifically as antipersonnel weapons, accidental exposure is possible. More importantly, damage from friend or foe is likely, and odds favor exposure in training sessions [2]. Two threat mechanisms exist: indirect and direct viewing of laser radiation. Indirect exposure results when laser radiation must pass through an intervening scattering medium, such as the atmosphere or an aircraft canopy, inducing diffused reflections, i.e., dazzle or glare. Direct viewing poses an immediate damage threat to the eye at energies above the thresholds [1] given in Table 1. Although not usually damaging to the eye, dazzle impairs vision and impedes the operator's continued functioning.

\*Spectral luminous efficacy allows radiometric units (those of the light source) to be converted to photometric units (those of the eye).

Table 1 — Hazardous Laser Light Levels

	Pulsed ( $< 5 \mu\text{s}$ )	CW (Short Exposure)
IR ( $> 1.4 \mu\text{m}$ )	15 mJ/cm <sup>2</sup>	40 mW/cm <sup>2</sup>
Near IR (0.7 - 1.4 $\mu\text{m}$ )	2.5 $\mu\text{J}/\text{cm}^2$	1.5 mW/cm <sup>2</sup>
Visible (0.4 - 1.1 $\mu\text{m}$ )	0.5 $\mu\text{J}/\text{cm}^2$	0.3 mW/cm <sup>2</sup>
UV ( $< 0.4 \mu\text{m}$ )	3 mJ/cm <sup>2</sup>	30 mW/cm <sup>2</sup>

Note: Much shorter pulses or long exposures ( $> 10\text{s}$ ) reduce the permissible levels further.

## LASER EYE PROTECTION

To define the broadest acceptable counter to the near-term eye threat, hardening in four spectral regions is required; broadband coverage in the ultraviolet and the near-infrared, and narrow-band coverage in the green (Nd:YAG/argon ion) and red (ruby). With the long list of potential threat systems capable of deployment, long-term filtering solutions will be characterized by the ability to harden against threats throughout the ultraviolet, visible, and infrared spectral regions. The goal is to obtain the maximum protection against deployed threats while retaining the maximum LEP luminous transmittance. Based on known technologies, the goals in the near-term are optical densities of at least 4 in the ultraviolet and infrared, and at least 3 in the visible.\*

Given a number of acceptable hardening designs, the most effective design for an LEP is determined by the anticipated lighting conditions and the environment in which it is used. For instance, in a confined environment with many obscurations, the damage potential for all but the outward-looking direction is significantly reduced. Where dazzle is the predominant threat, protection is easily provided with low optical-density LEP. Also, the physical form of the LEP should be considered in terms of use to provide maximum comfort and protection. While a helmet visor is practical for the aviator, an eyeglass form is more practical for a tanker, and a wraparound for the ground troop. Whenever possible, the LEP should be built into another system to reduce the human participation required in its use. Thus, LEP should be installed in any direct view optics. Also, all should provide ballistic projectile protection.

## LEP FILTER MATERIALS

Generally, all LEP filters can be classified as absorbers (dye-impregnated polycarbonates and colored glasses), interference materials or power limiters. These classes are discussed in accordance to their salient hardening features and any of their limitations. Several specific filters were chosen for study to illustrate how spectral differences in the filter materials alter the effectiveness of the LEP in terms of transmittance. These materials were measured to verify their spectral characteristics. Details of the filter measurement are included in Appendix A.

\*These optical densities are determined with calculations using the equations and threat parameters in Ref. 1 based on the known energies, divergencies and anticipated pathlengths for deployed lasers.

Dye-impregnated polycarbonates are available with a variety of filtering capabilities. The material is made by uniformly dispersing one or more dye absorbers throughout the polymer medium. Because of the uniform distribution of absorber throughout the medium, laser protection is not affected by scratches or surface marring. The polymers used provide excellent ballistic impact resistance, but their optical quality is often inferior to that of glasses. Optical densities are easily changed with dye absorber concentration, and molding into a variety of shapes is possible. Unfortunately, nondivergent laser beams at large power densities are capable of boiling or melting the polycarbonate filters, thus causing unexpected burnthrough, but this is not an existing battlefield problem because laser radiation is generally of the diffuse targeting type. Some dye-impregnated polymers, however, lose their filtering capability over periods of time because of age or exposure to sunlight; this degeneration is known as solarization.

Colored glasses composed of dissolved or suspended coloring agents in glassy materials have been used for their filtering capabilities for a long time. Many visible filters are available, but the selection of infrared filters is limited. These filter materials are uniform, are not altered by minor scratching, and have excellent optical quality. Optical densities of colored glasses are difficult to control in the manufacturing process; instead, optical densities are determined typically by the glass thickness. Colored glasses are subject to thermal shock, impact shock, and solarization.

Interference filtering materials including holographic transmittance gratings and dielectrics make up a broad class of materials that rely on interference with light to provide their filtering capabilities. The most important feature of this class of filtering materials is that extremely narrow rejection bands are possible (as low as 5 nm), thus maximizing the overall luminous transmittance of the filter. However, all of these materials exhibit strong dependence on the angle of the incident radiation; as designed, only light normal to the material is strongly filtered.

Nonlinear optical materials or power limiters, such as optical switches and liquid crystals, are thought to be critical as future hardening materials. Such materials are designed to switch from transparent to opaque when hit by radiation exceeding a specified threshold. Limiters have been constructed to counter nanosecond-pulse threats across a broad spectral region. As a still immature technology, current designs are limited as LEP, especially with high pulse repetition frequency or continuous-wave lasers. At high frequency, a simple limiter will be opaque to the eye, effectively blinding the user; fast electronics will not be affected by this timing problem. Research efforts on power limiters have intensified in recent years [3]. Figure 3 shows a spectrum for a slow (ms) low optical-density liquid-crystal limiter.\* Although the spectral response of the filter is uniform, the optical density is low, and the temporal response is unacceptably slow.

Several specific filter materials are also discussed in detail; they include infrared blocking materials, polycarbonate filters that protect in the green, and multiple-wavelength LEP. These materials are evaluated for LEP, as specified, for spectral blocking capabilities and optical densities. Visual acuity is also assessed. Table 2 gives percent luminous transmittances (ratio of filtered and unfiltered eye response without regard to lighting conditions) for the filter materials.

Two promising materials that provide infrared hardening are Schott Glass Technologies BG39<sup>†</sup> and Fred Reed Optical KG3<sup>‡</sup> glasses, see Figs. 4 and 5. The BG39 spectrum extends further into the

\*The liquid crystal limiter was provided by John Lang, Optical Protection Incorporated, 503 N. Roosevelt Boulevard, Falls Church, VA 22044.

†Schott Glass Technologies, 400 York Ave., Duryeo, PA 18643.

‡Fred Reed Optical Co., 127 Bryn Mawe, SE, Albuquerque, NM 87125.

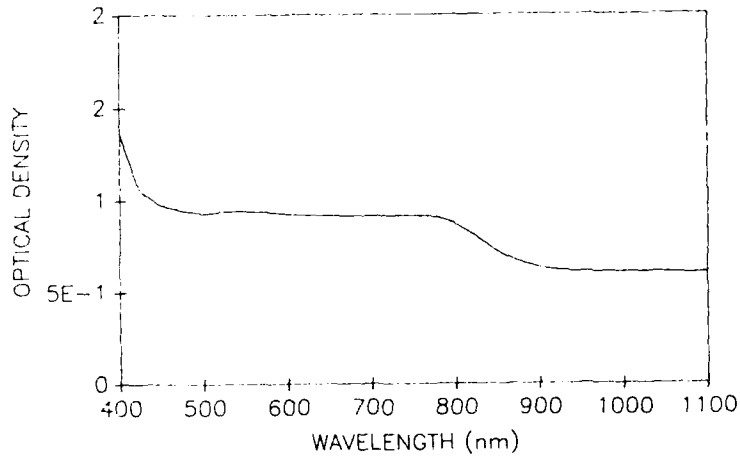

Fig. 3 — Liquid crystal limiter spectrum\*

Table 2 — Luminous Transmittance

Material	LT(%)
BG39	65
KG3	72
Heat reflecting	
Glendale NDGA	30
Glendale argon ion	48
Gentex FB1	55
FB1/KG3	40
Argon ion/KG3	35
FB1/BG39	35
Argon ion/BG39	31
Glendale FV2	24
GEC hologram	36
Glendale 89A	28
Glendale B	45
Glendale C	15

\*The liquid crystal limiter was provided by John Lang, Optical Protection Inc., 503 N. Roosevelt Blvd., Falls Church, VA 22044.

JEANNE A. WELCH

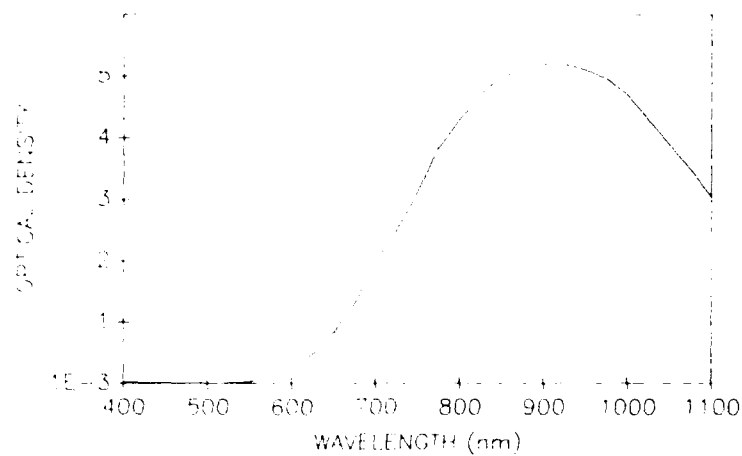

Fig. 4 — Schott Glass Technologies BG39 filter spectrum, 1 mm thickness

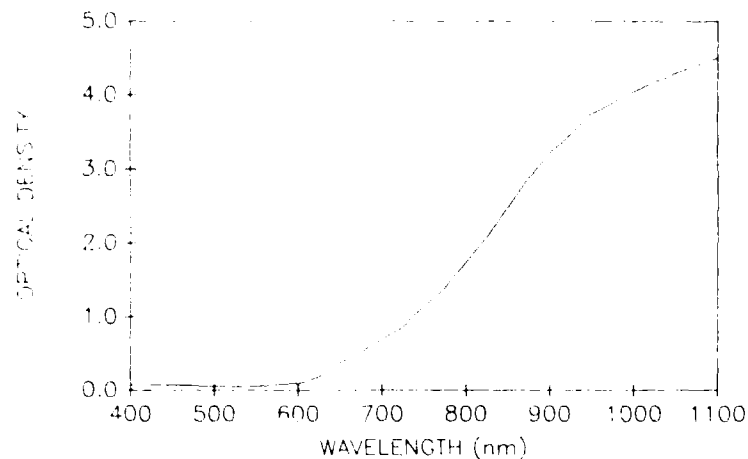

Fig. 5 — Fred Reed Optical KG3 filter spectrum, 3 mm thickness

visible than does that of KG3. This reduces the luminous transmittance of the BG39 with respect to KG3, Table 2, but improves BG39 blocking capabilities against the Alexandrite (vibronic) and Ruby lasers. However, BG39 filters in the spectral region corresponding to the output of a pilot's heads up display, thereby reducing its effectiveness. Still, BG39 is the filter of choice in most threat situations.

Other infrared-blocking materials include the Spindler and Hoyer heat-reflecting filter\* in Fig. 6 and the Glendale Protective Technologies NDGA polycarbonate† in Fig. 7. The heat-reflecting filter or hot mirror is not a recommended hardening material, because the optical density is low and reflections from it can also yield hazardous laser radiation levels. The polycarbonate filter blocks throughout the visible and infrared spectral regions and yields substantially less luminous transmittance than materials discussed previously do; see Table 2.

\*Spindler and Hoyer, 459 Fortune Blvd., Milford, MA 01757.

†Glendale Protective Technologies, 130 Crossways Park Dr., Woodbury, NY 11707.

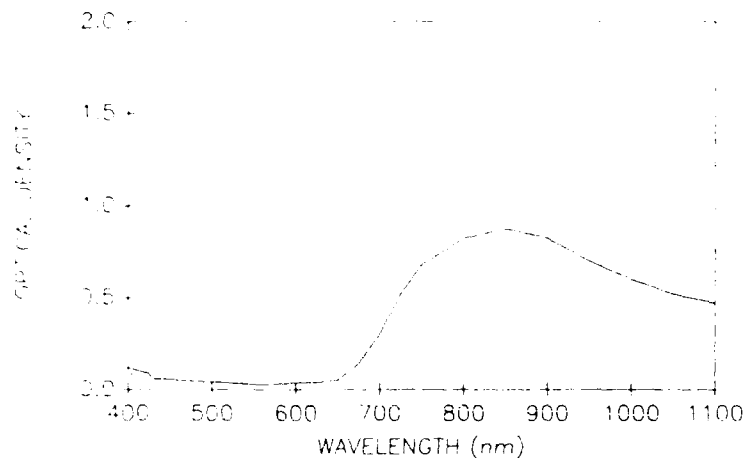

Fig. 6 — Spindler and Hoyer heat reflecting filter spectrum

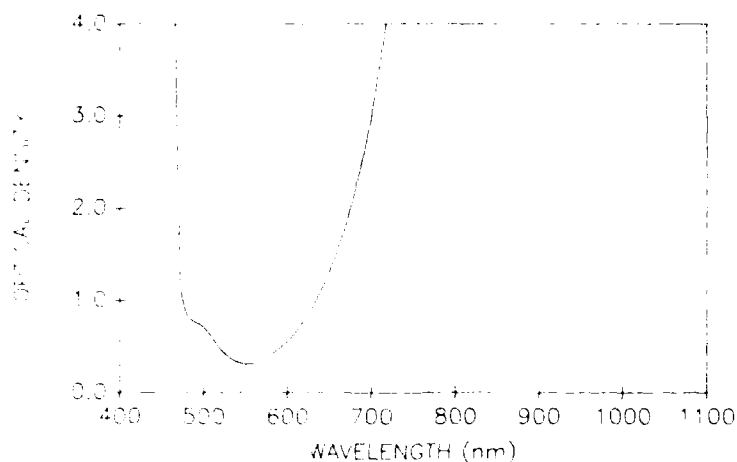

Fig. 7 — Glendale Protective Technologies NDGA filter spectrum

Two materials that show promise for laser hardening in the green are the Glendale Protective Technologies Argon ion polymer\* and the Gentex FBI polymer† shown in Figs. 8 and 9. The Gentex (FBI) provides minimally higher luminous transmittances than does the Glendale Protective Technologies by transmitting more of the blue spectrum. Both materials provide impact protection and can be easily shaped. Also, both provide protection throughout the ultraviolet. Because the Gentex filter provides marginal protection at doubled Nd:YAG (2% with a 1.5 mm thick sample), the argon ion filter is preferred. FBI optical densities at doubled Nd:YAG can be improved if thick or concentrated samples are used. Any hardening material that blocks argon ion/doubled Nd:YAG also blocks an important cockpit phosphor. The phosphor is being redesigned.

In many laser bands protection can be provided by stacking filters, such as the infrared-blocking and green-blocking filters already discussed, see Figs. 10 through 13. In addition to the advantage of

\*Glendale Protective Technologies, 130 Crossways Park Dr., Woodbury, NY 11707.

†Gentex, Carbondale, PA 18407.

JEANNE A. WELCH

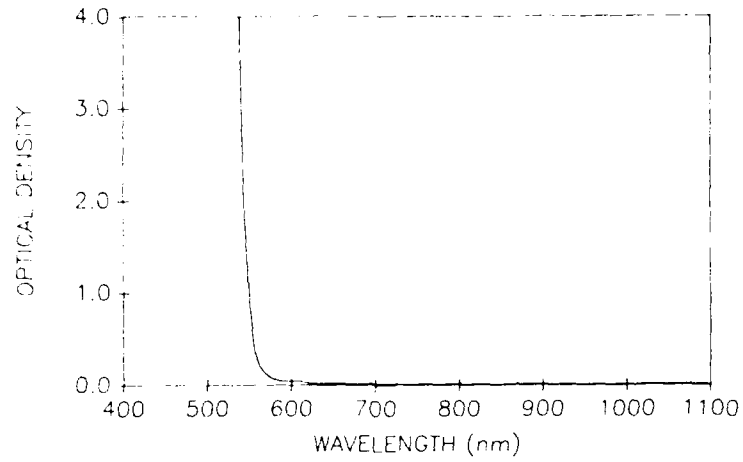

Fig. 8 — Glendale Protective Technologies argon ion filter spectrum

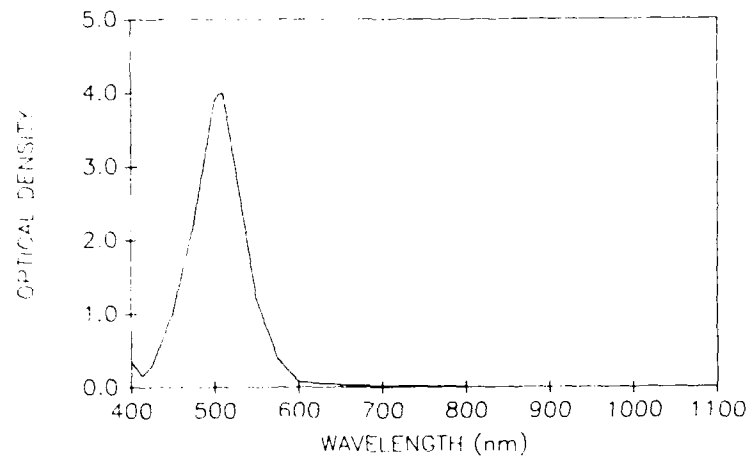

Fig. 9 — Gentex FBI filter spectrum, 1.5 mm thickness

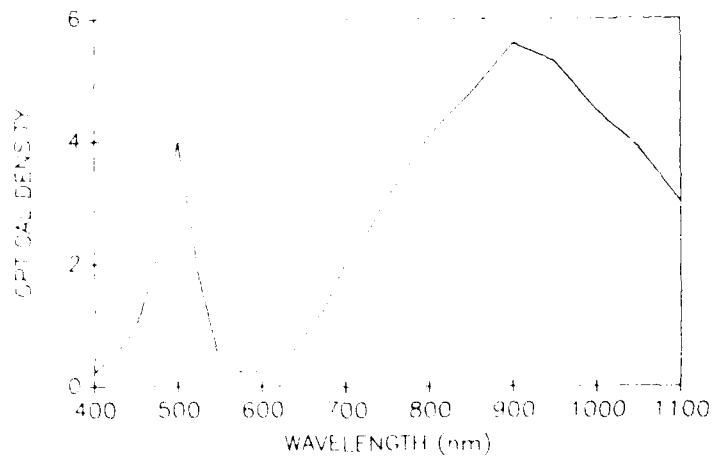

Fig. 10 — FBI/BG39 combination filter spectrum

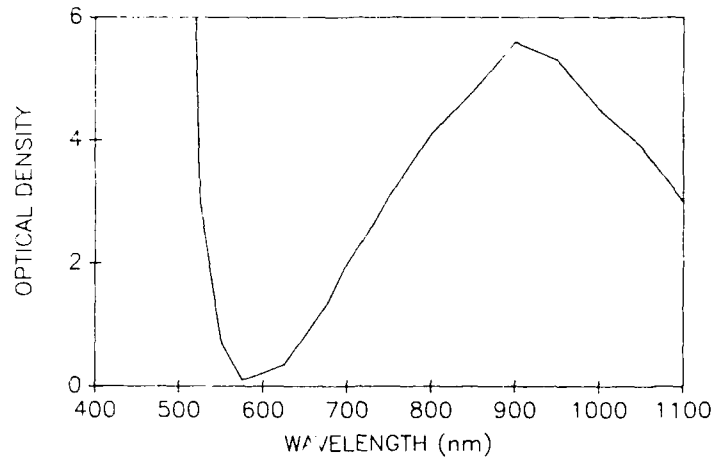

Fig. 11 — Argon ion/BG39 combination filter spectrum

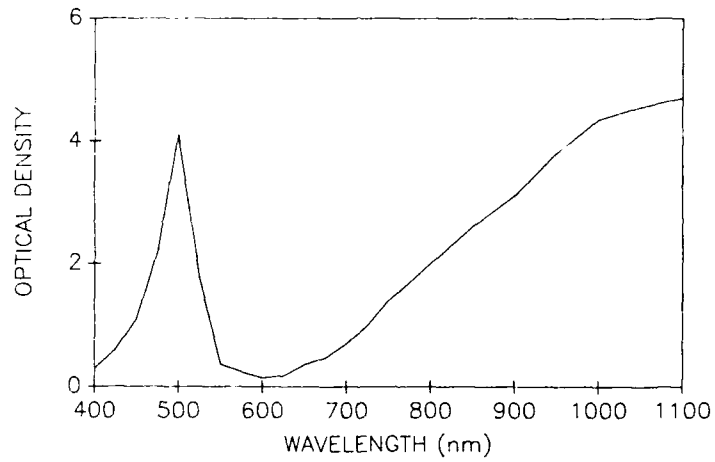

Fig. 12 — FBI/KG3 combination filter spectrum

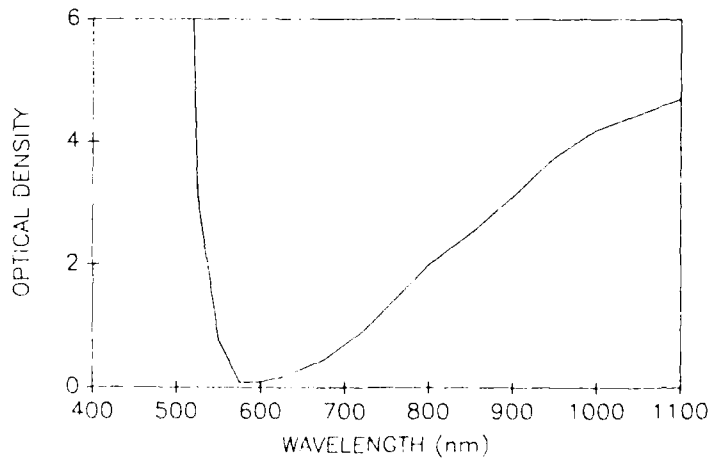

Fig. 13 — Argon ion/KG3 combination filter spectrum

multiple laser rejection, stacked combinations can be engineered as single element or as multiple-component designs; deployment dictates the final design. All are subject to the combined limitations cited.

Figure 14 shows the spectrum of the Glendale Protective Technologies TGBS1/FV2 (see \* footnote on page 7). This filter provides adequate protection in all specified laser regions. Table 3 gives the optical densities measured at several laser lines. At 488 nm, the reflectance of the LEP is approximately 20%. This is higher than expected for an ordinary spectacle and suggests that specular reflections from this LEP are potential hazards. The LEP protects throughout the infrared and is suitable to counter Alexandrite lasers. Laser hardening exists at the ruby wavelength and is also present at the green wavelength. The FV2 measured is available in a standard aviator frame and is lightweight and comfortable.

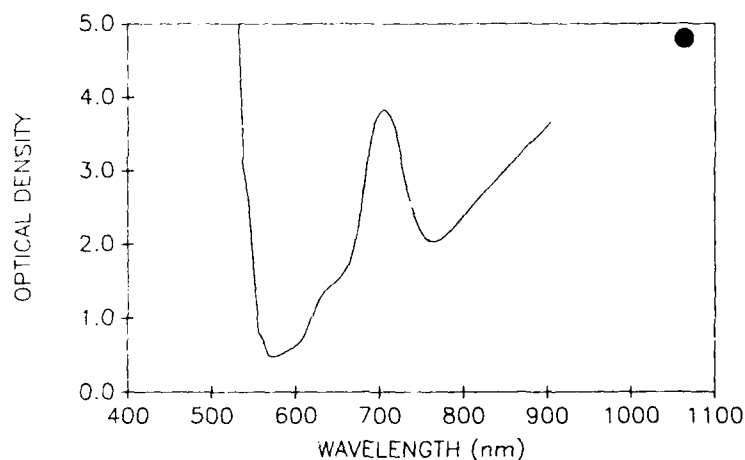

Fig. 14 — Glendale Protective Technologies TGBS1/FV2 filter spectrum

Table 3 — FV2 Optical Densities

Wavelength	Optical Density
1064	4.8
694	3.9
633	1.4
532	5.0
514	>4.7
488	>>4.4

Reference 4 gives a discussion of the GEC Avionics\* holographic filter. This filter provides adequate protection in one spectral band but only marginal or poor protection throughout the rest of the spectrum. The dependence of the filter on incident angle results in a  $\pm 30^\circ$  field of regard. Other measurements [3,5] have reported fields of regard as low as  $\pm 20^\circ$ . This LEP was measured in an aviator-like frame.

\*GEC Avionics Inc., 2975 Northwoods Parkway, Atlanta, GA 30366.

Three other commercial materials are available but have proved to be of limited value. The Glendale Protective Technologies 89A is basically a lower optical density version of the FV2, however it does not provide adequate protection in the visible; see Fig. 15. This LEP was measured as a helmet visor. The Glendale Protective Technologies broad spectrum "B" (Fig. 16) and "C" series provide extensive spectral protection but are strictly laboratory safety glasses with low luminous transmittances and intended to be used under restricted operating conditions.

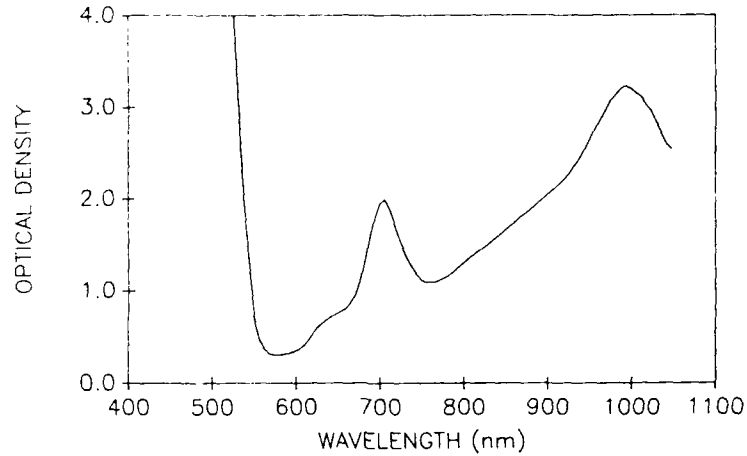

Fig. 15 — Glendale Protective Technologies 89A filter spectrum

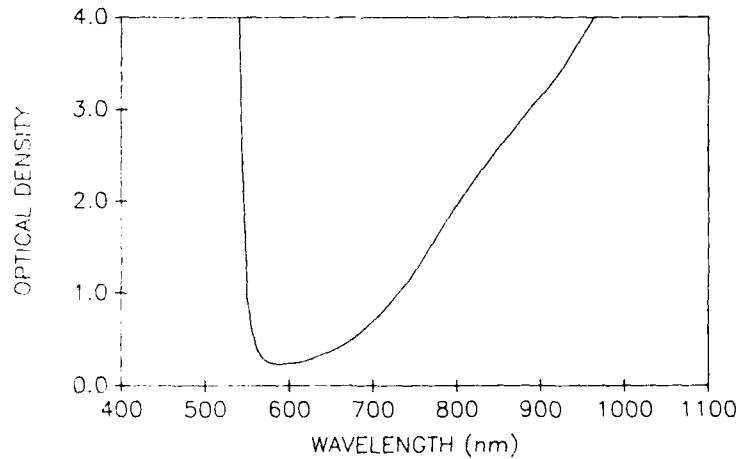

Fig. 16 — Glendale Protective Technologies LGB filter spectrum

An additional laser threat is introduced when either the Copper vapor laser or Raman shifting complicates the LEP scheme by blocking virtually all visual spectral response, see Fig. 1. This complication eliminates colored filters and dye-impregnated polymers as effective LEP alternatives because of the broadness of their spectra. Narrow-band interference filters or holograms remain a possibility, but multiple-wavelength LEP luminous transmittances would be reduced significantly. This stresses the need for broadband LEP, such as power limiters, to counter the anticipated future threat. As a result, extensive research on power-limiting materials is now in progress [4] and could produce an effective laser hardening alternative in the future. Ultimately, to obtain transparency at high pulse repetition frequencies and to provide effective protection, a power limiter requires partial opacity in the visible.

### LEP EFFECTIVENESS

Obviously several designs meet the general requirements that define adequate near-term laser protection: the FV2 and four stacked combinations: Gentex and argon ion filters in combination with BG39 and KG3 filters. To further refine the choice of LEP, several factors must be considered; they include how and where the LEP is used.

The most effective physical form for the LEP may dictate the choice of hardening materials. For instance, a glassy material is not appropriate for an aviator visor but is acceptable for laser spectacles, especially if optical quality or visual correction is an issue. Similarly, easily damaged materials such as in the interference-type filters are not employed in harsh environments that rapidly degrade the interference coatings. Therefore, the most effective LEP design must be determined for each viewing condition.

The best LEP provides adequate protection against the threat while it provides the highest transmittance of photons to the retina. For the human eye, integrating the transmittance of the eye, the lighting conditions, and the filtering over the visible spectrum give the illuminance of photometric flux (lumens) reaching the retinal surface.

$$E_f = \int \tau_f(\lambda) f_{eye}(\lambda) f_{light}(\lambda) d\lambda$$

Here

- $\tau_f(\lambda)$  is the transmittance of the filter,
- $f_{eye}(\lambda)$  is the photopic or scotopic transmittance of the eye, see Fig. 2, and
- $f_{light}(\lambda)$  is the incident spectrum.

Figures 17 and 18 show typical day and night spectra. The above equation is generalized to any sensor by substituting  $f_{sensor}(\lambda)$  for  $f_{eye}(\lambda)$ .

Correlation of the transmitted flux to visual acuity and range is not straightforward. For instance, removal of the blue end of the spectrum, where light scattering (glare) is the greatest, can improve contrast perceptibly. To a first approximation, however, it is assumed that a material yielding a higher integrated illuminance leads to improved visual acuity that in turn yields longer viewing range.

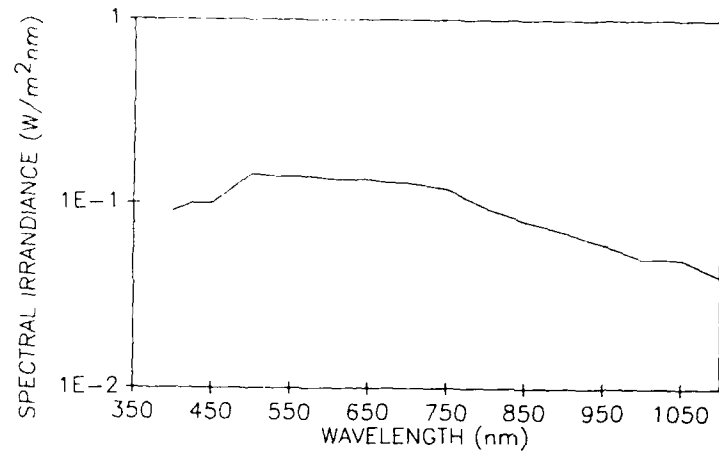

Fig. 17 — Solar irradiance at sea level [6]

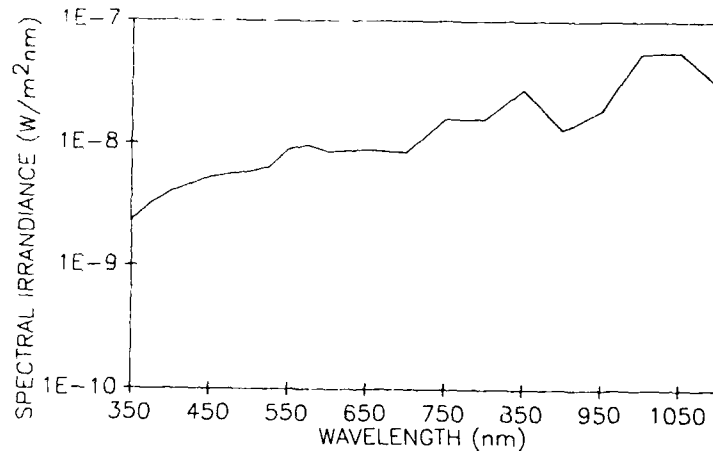

Fig. 18 — Natural night sky spectral irradiance

Representative calculations that use the two-lighting conditions in Figs. 17 and 18 are reported here. Figures 19 through 23 show the convolved daylight (photopic) spectral illuminances of the most effective LEP designs, and Figs. 24 through 28 show the corresponding night-light (scotopic) spectral illuminances. Table 4 reports the integrated illuminance reaching the retina.

## CONCLUSIONS

Of the LEP hardening packages, the FV2, Gentex/BG39 or argon ion/BG39 is preferred for near-term deployment. The FV2 is relatively inexpensive and commercially available, while either combination filter would have to be designed and developed. On the basis of the simple physical examination of the filter transmittance characteristics, all three LEP designs provide comparable and adequate coverage. Both combination filters provide adequate protection in the infrared and at the ruby wavelength. The argon ion/KG3 protects both the argon ion and doubled Nd:YAG bands, while the Gentex filter does not at doubled Nd:YAG. The Gentex filter can be modified by concentrating the dye absorber to provide more protection. This lowers the luminous transmittance of the Gentex/KG3 combination to a level comparable to that of the argon ion/KG3. Also, the BG39 stacked combinations protect against near-infrared vibronic lasers.

JEANNE A. WELCH

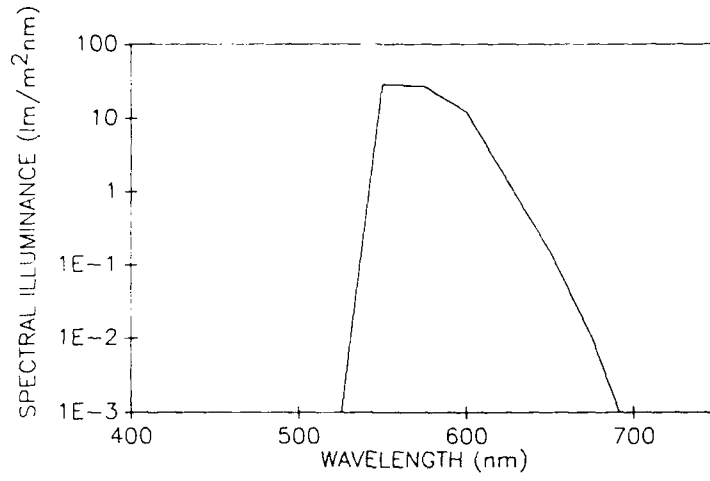

Fig. 19 — FV2 daylight illuminance

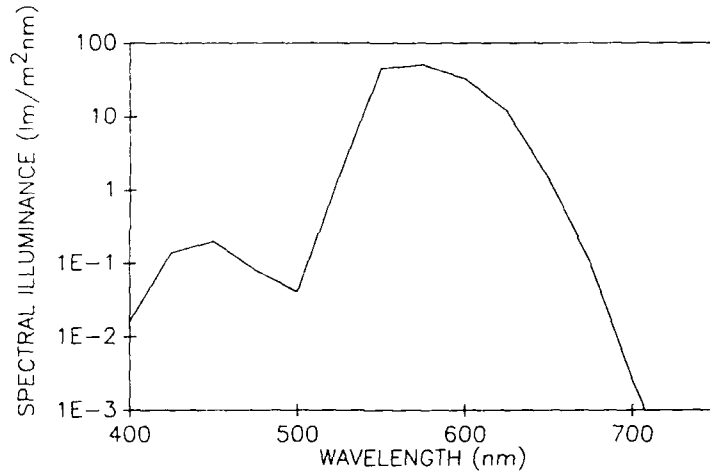

Fig. 20 — FB1/BG39 daylight illuminance

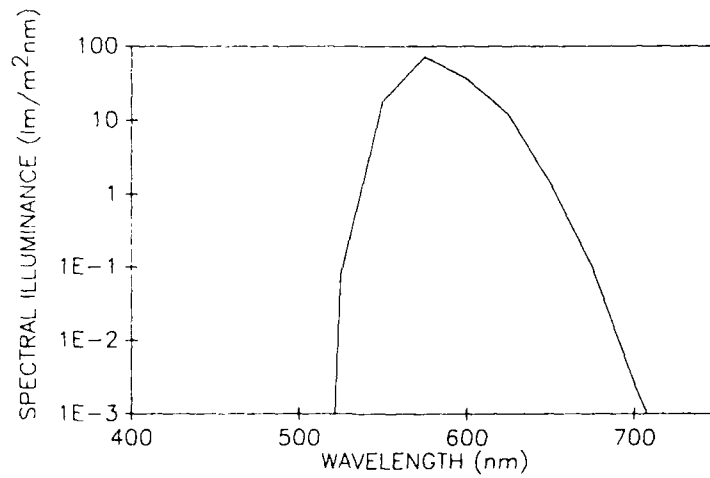

Fig. 21 — Argon ion/BG39 daylight illuminance

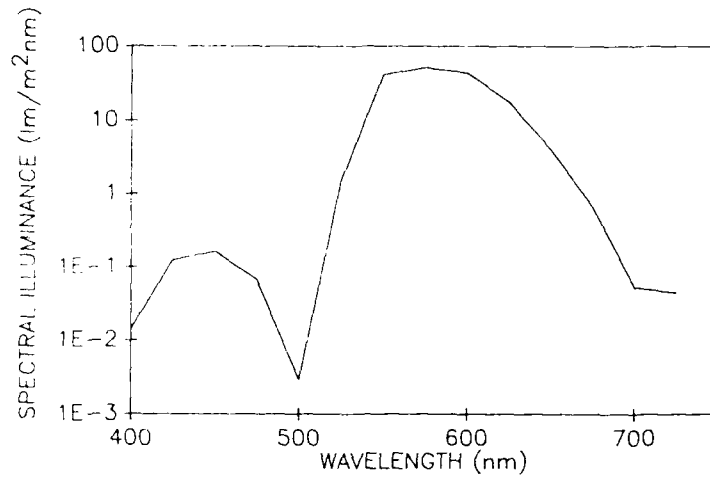

Fig. 22 — FBI/KG3 daylight illuminance

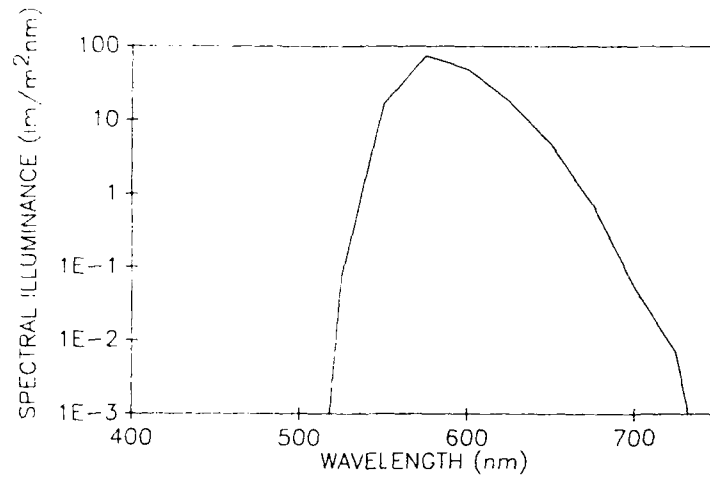

Fig. 23 — Argon ion/KG3 daylight illuminance

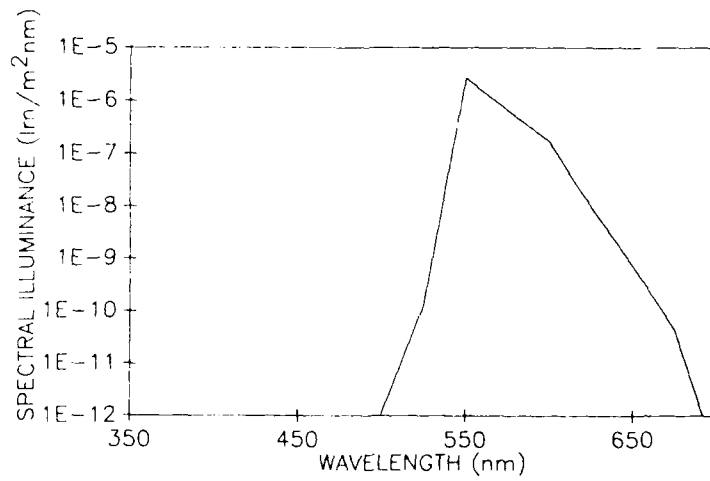

Fig. 24 — FV2 nightlight illuminance

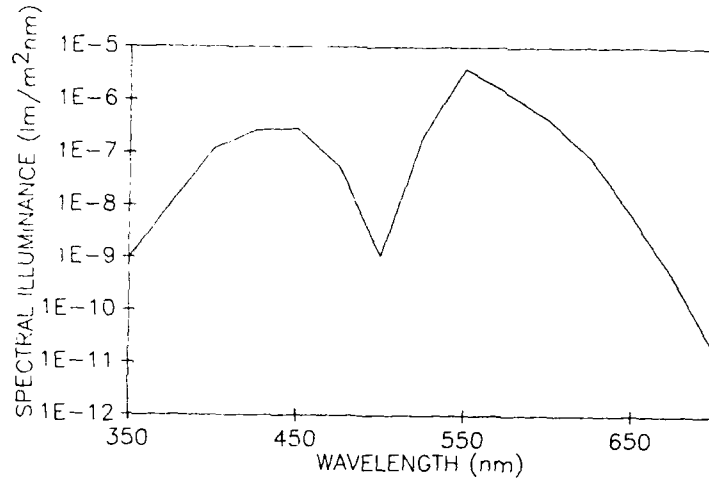

Fig. 25 — FBI/BG39 nightlight illuminance

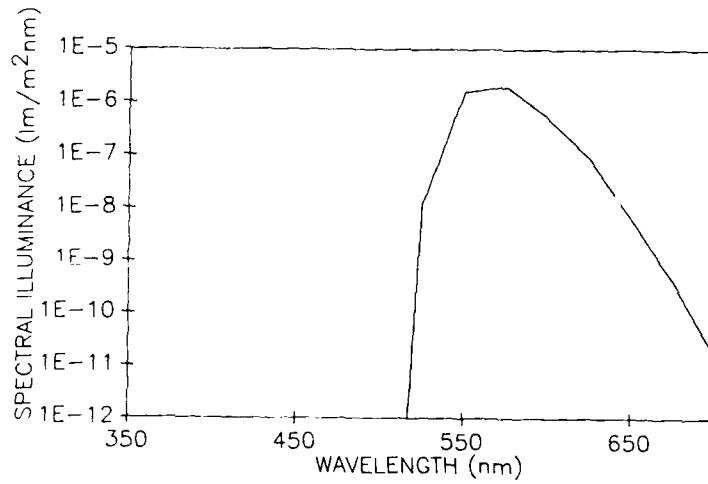

Fig. 26 — Argon ion/BG39 nightlight illuminance

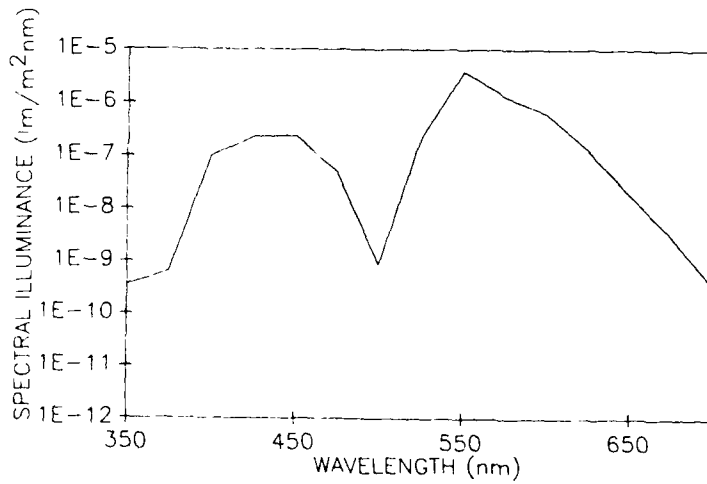

Fig. 27 — FBI/KG3 nightlight illuminance

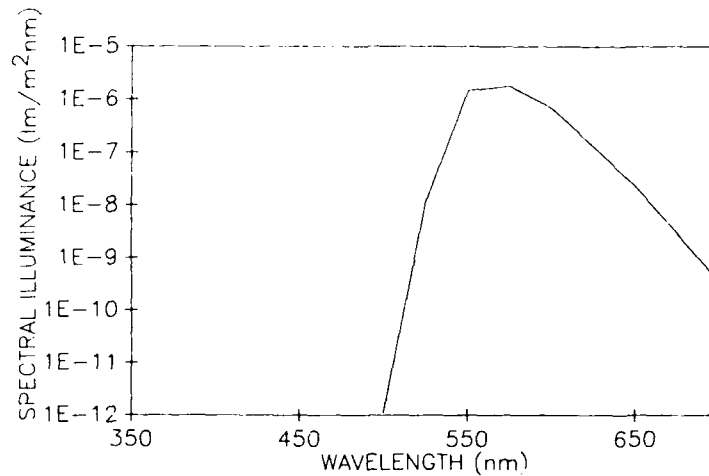

Fig. 28 — Argon ion/KG3 nightlight illuminance

Table 4 — Illuminance ( $lm/m^2$ )

Filter	Nightlight Scotopic	Daylight Photopic
None	$2.4 \times 10^{-6}$	$1.0 \times 10^5$
FV2	$1.8 \times 10^{-7}$	$1.7 \times 10^4$
Gentex/KG3	$2.6 \times 10^{-7}$	$4.0 \times 10^4$
Argon ion/KG3	$1.1 \times 10^{-7}$	$4.1 \times 10^4$
Gentex/BG39	$1.7 \times 10^{-7}$	$3.6 \times 10^4$
Argon ion/BG39	$1.1 \times 10^{-7}$	$3.5 \times 10^4$

On the basis of the light transmitted to the eye, see Table 4, the choice of LEP is more clear-cut. The argon ion/BG39 is slightly favored in daylight viewing, and the Gentex/BG39 is slightly favored at night when the night-light is noticeably shifted to the blue end of the spectrum.

A more detailed investigation of visual acuity is required for future eye protection. A real need exists for physical experimentation to correlate visual acuity to filtering and lighting conditions. This investigation must be conducted in an environment where there are strict, reproducible lighting conditions. Ideally, the lighting is variable from full sun to 100% overcast starlight to achieve the most detailed results. To avoid subjective visual examinations, some form of image processing system must be employed for target recognition. The best facility for night vision is the Dark Tunnel Facility associated with RSRE in Malvern, England. But other, more limited, facilities exist. Appendix B gives a reprinted description of the Dark Tunnel Facility with typical night lighting conditions in Figs. B1 and B2. Finally, long-term exposure studies should be undertaken in the future to determine if an LEP is robust.

JEANNE A. WELCH

**REFERENCES**

1. "American National Standard for the Safe Use of Lasers," ANSI Z136.1-1986 (1986). "Controls of Hazards to Health from Laser Radiation," Department of the Army Technical Bulletin TB MED 254, 1985.
2. A.M. Johnson "Eyesafe Lasers for Military Use," *Lasers and Optronics*, June 1988.
3. B.C. Nordwall, "Laser Advances Spur Pentagon Efforts to Protect Flight Crewmember's Eyes," *Aviation Week and Space Technology* (1988).
4. J.A. Welch "Transmittances Studies of Two Antilasars Spectacle Materials," NRL Memorandum Report 5994, 1987.
5. J.B. Sheehy, "Optical Evaluation of Instrument Interference Filters," Report No. NADC 85065-60, 1985.
6. L.J. Pinson, *Electro Optics* (J. Wiley and Sons, New York, 1985).

## Appendix A

### EXPERIMENTAL OPTICS AND ELECTRONICS

A visible-near-infrared spectrum for each of the laser hardening materials has been verified by the optical layout shown in Fig. A1. A quartz-halogen lamp and monochromator were used for the relative spectral measurement, and a calibration laser and power meter were used for the absolute transmittance and to verify measurements of optically dense materials.

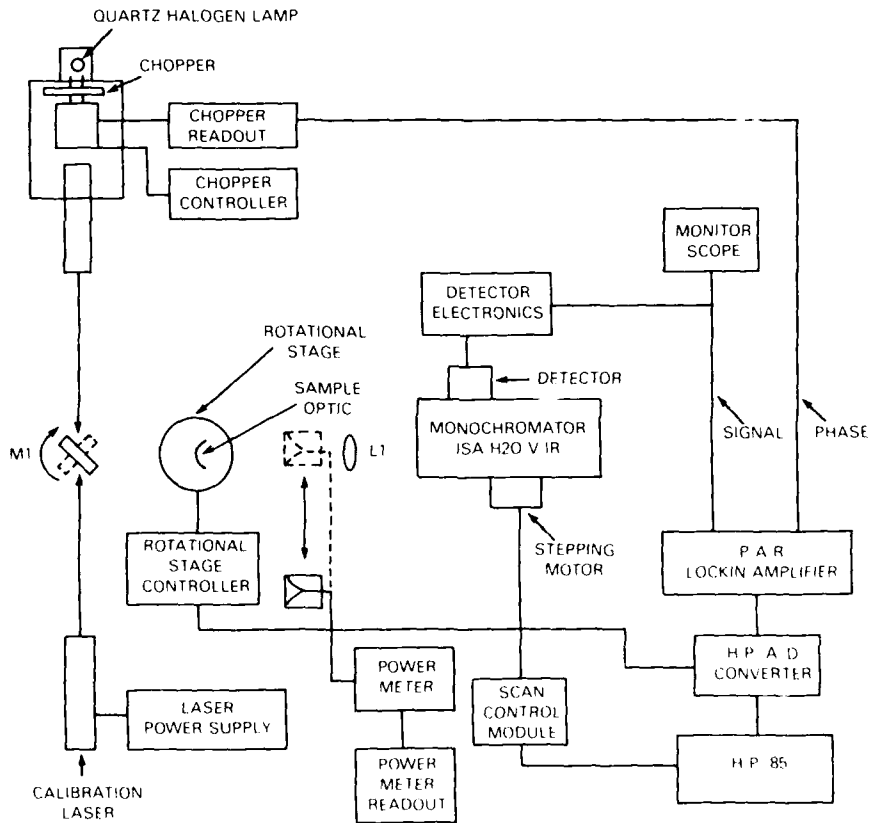

Fig. A1 — Schematic representation of the filter transmittance experiment

The 0.2 m Instruments SA monochromator has a stepping-motor driven, 800-grooves/mm, holographic grating blazed at 600 nm with a spectral range of 300 to 1100 nm. The 0.5-mm entrance and exit slits give an equivalent slit width of 3 nm. For each measurement, the spectrum between 400 and 1100 nm has been covered in 233 resolution-limited steps of 3 nm.

The light source for the spectral measurement was a quartz-halogen lamp with a tungsten filament. The output beam was incident normal to the filter. Several of the laser hardening materials investigated were molded with curved surfaces. To reduce interference in the signal by diffracted light incident at angles other than normal, the beam was narrowed to 0.3 cm with an iris. This provided a minimal spot on the curved material without reducing the signal intensity significantly. The beam was focused onto the entrance slit by a single 100 mm focal-length lens. The detector was a silicon diode that sat directly at the exit slit. To eliminate background noise, the source was chopped at 370 Hz.

A Stanford Research Systems Model SR530 or a PAR Model 5204 lock-in amplifier with a 0.3-s time constant was used for data collection with the chopper providing the reference signal. To facilitate the data collection and analysis, the output of the lock in was processed with an HP59313A A/D converter and an HP85A desktop computer.

To verify the angular response, data were collected with the hardening filter material mounted on a rotational stage with the two-rotational axes aligned. When the filter was rotated, a sample area of interest on the filter was probed with respect to angle of incidence.

To determine the absolute transmittance spectra reported here, the raw spectrum, the baseline or source spectrum, and, for at least one wavelength, the absolute transmittance are required.

The baseline spectrum is the result of the combination of the individual spectra of the radiation, the monochromator grating, the detector, the optics, and the intervening atmosphere. By removing this strong intensity variation over the spectral region of interest, the sample is normalized.

The absolute transmittance measurement at one well-defined wavelength provides baseline calibration. A laser works well in calibration work because the output is spectrally narrow, which allows the beam to pass through the sample without obscuration. Measurement with a power meter before and after the test sample gives the extinction at the calibration laser wavelength directly. Several lasers, including an HeNe, an Nd:YAG, a doubled Nd:YAG, and an argon ion were used for the absolute transmittance measurements.

**Appendix B**  
**ELECTRO-OPTICS ASSESSMENT FACILITY**

The main purpose of this facility is to provide a simulation of night-sky-lighting conditions so that assessments of night-vision equipment can be carried out at any time under controlled conditions rather than conducting field trials at night when conditions are not controllable (Figs. B1, B2).

The lighting system provides nine levels of illuminance ranging from twilight through moonlight, down to overcast starlight that is 1000 times darker than moonlight. These nine levels are spectrally corrected, that is they have the correct color and infrared content to provide a reasonable match to published data for natural-night-sky levels (Figs. 23, 24). In addition, there are two higher light levels that are not spectrally corrected to simulate the higher twilight region so that the cross over from day-sight to night-sight operation can be assessed under controlled conditions.

The lighting system consists of 81 raft, that have been hung in a specified array. Each raft contains forty tungsten lamps, each individually housed with the appropriate color or infrared filter and aperture at the output of the housing. Combinations of lamps on each raft are switched on depending on the light level selected. A different combination of lamps is used for each light level. The type of lamp used has a rated life of at least twice that of a standard tungsten lamp, and it is underrun by 6%, from a stabilized supply to increase the life even more. A fault monitoring control unit detects and shows the location of the failure of any of the 3240 lamps used in the system. The lighting system provides a high degree of uniform lighting at floor level that is approximately 1 acre in area.

The system is controlled by a master control unit that can be plugged in at various places in the tunnel area. Each of the four viewing rooms has a control point socket, but only one master control unit can be used at one time. All viewing rooms have a light level display panel if required.

Since the *dark tunnel* floor is approximately 100 m by 40 m, the horizontal field of view is 20°, and the vertical field of view is 5° when looking at the target wall from the viewing rooms. This large area of simulated night-illumination condition also enables mobility experiments to be carried out. There is a battery powered *golf caddy* vehicle to which low-light driving aids can be fitted for assessment.

Several types of targets are available; large USAF type resolution patterns, scale models of various tanks, and APCs. The models are of 1 to 10 and 1 to 20 scale, and some can be radio controlled to provide moving targets. *Action Men* in correct-service-camouflage clothing provide good man-target simulation.

The *dark tunnel* floor has been painted with a special paint to provide a reasonable match to the spectral reflectivity of natural grass. A natural grass bank is also available with coniferous bushes as a realistic background that can be wheeled into position.

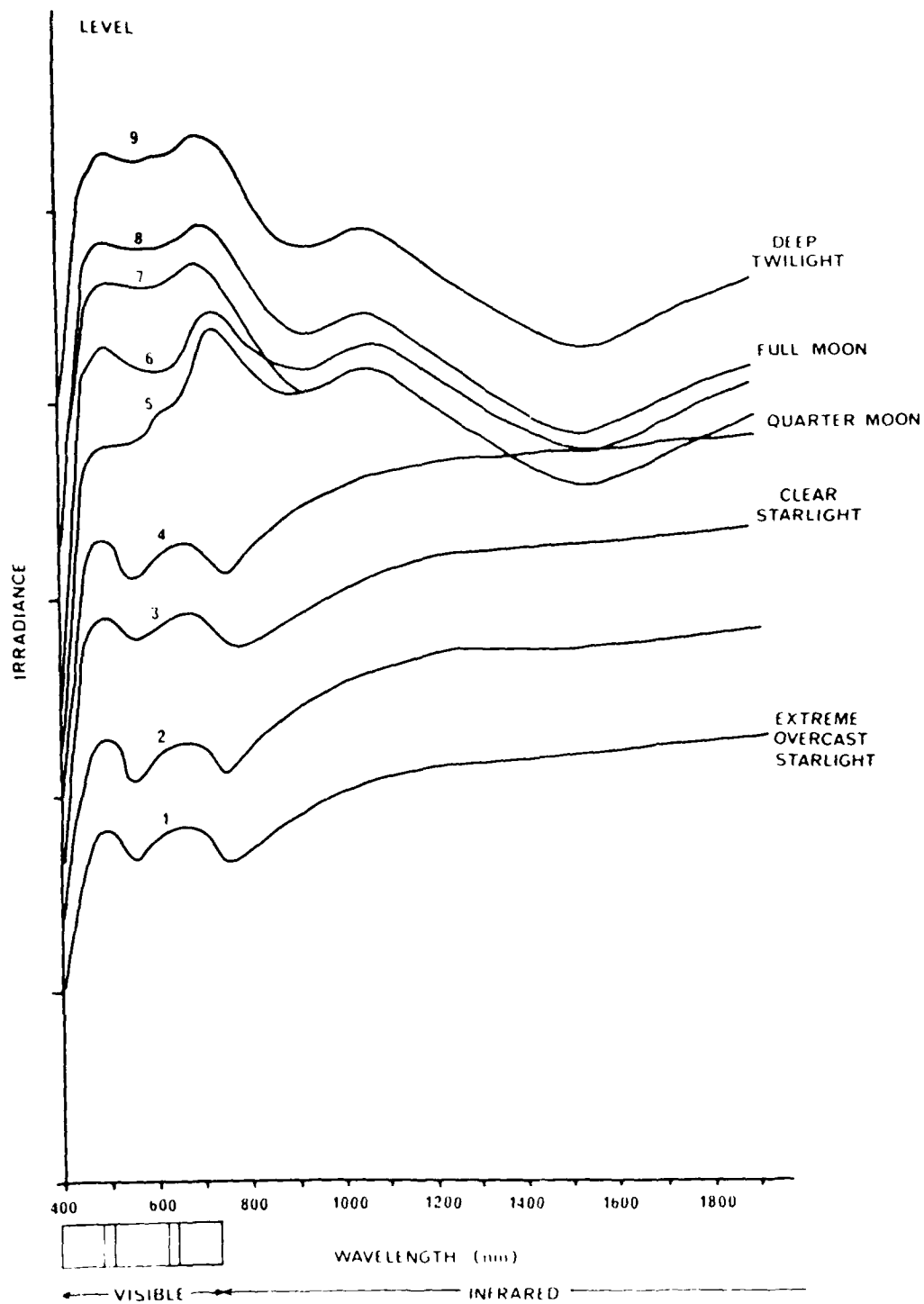

Fig. B1 -- Nightlight irradiances\*

\*This description was reproduced from material provided by the Dark Tunnel Facility.

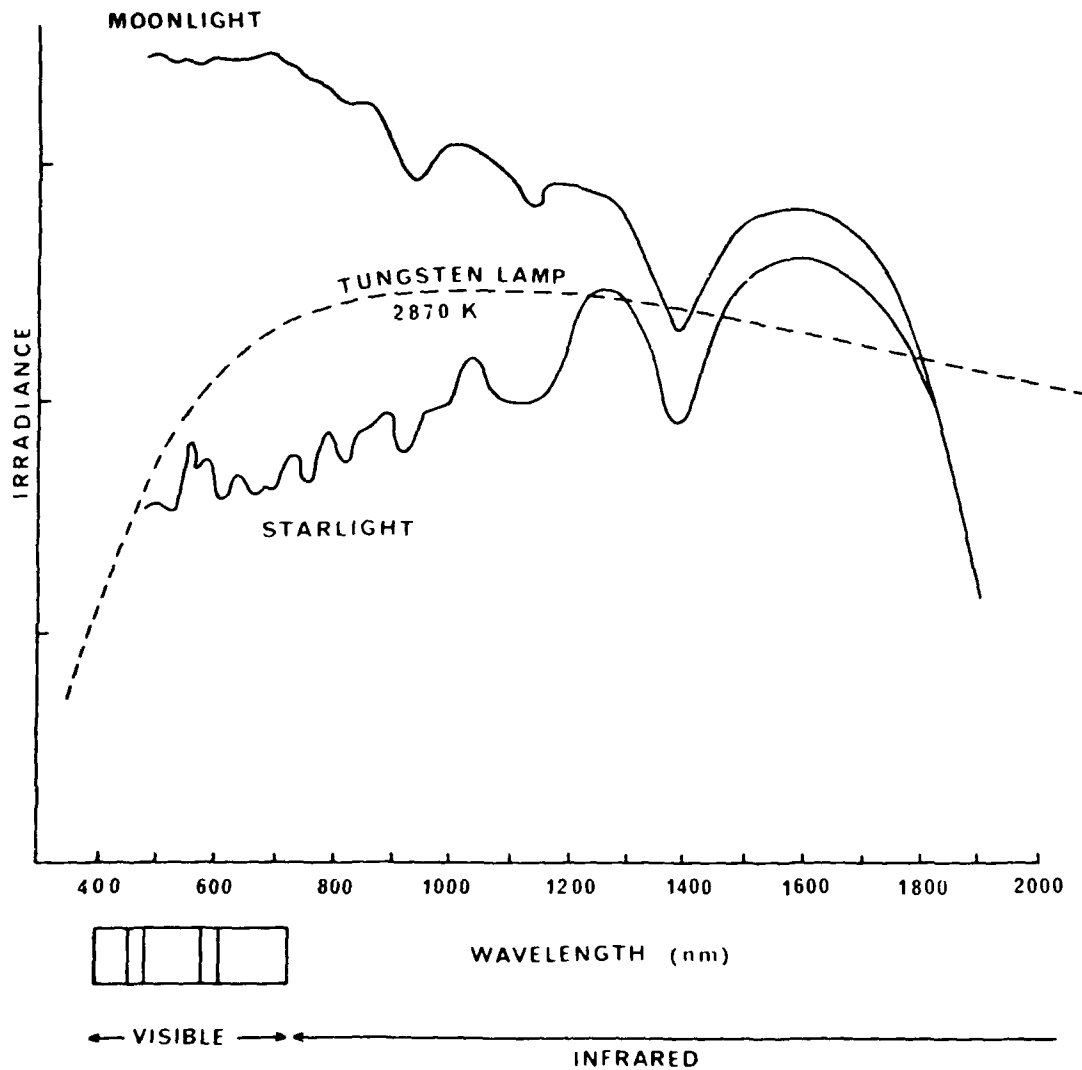

Fig. B2 — Dark Tunnel irradiance vs starlight and a 2870 K tungsten lamp\*

An access point exists next to the viewing rooms where full size vehicles can be brought in, providing the floor is adequately protected. The vehicle bay can be used to house vehicles during assessment, and has a 1 ton hoist to allow work to be performed on the vehicles.

All access doors are fitted with a laser interlock system that has intruder alarm and auto cut off to allow the use of class 4 lasers within the facility.

A steel bullet catcher has been built on the target wall to allow live firing of small bore ammunition under controlled low-light conditions.

\*This description was reproduced from material provided by the Dark Tunnel Facility.