

4

FILE COPY

RADC-TR-89-170
Final Technical Report
October 1989



AD-A213 367

CONFIGURATION DEVELOPMENT FOR ROMENET

RJO Enterprises, Inc.

Lawrence Rhue

APPROVED FOR PUBLIC RELEASE; DISTRIBUTION UNLIMITED

DTIC
ELECTE
OCT 04 1989
S **D**
CB

ROME AIR DEVELOPMENT CENTER
Air Force Systems Command
Griffiss Air Force Base, NY 13441-5700

89 10 4 038

This report has been reviewed by the RADC Public Affairs Division (PA) and is releasable to the National Technical Information Service (NTIS). At NTIS it will be releasable to the general public, including foreign nations.

RADC-TR-89-170 has been reviewed and is approved for publication.

APPROVED:

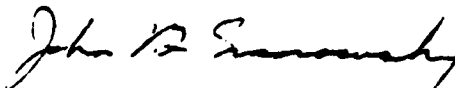

JOHN B. EVANOWSKY
Project Engineer

APPROVED:



JOHN A. GRANIERO
Technical Director
Directorate of Communications

FOR THE COMMANDER:

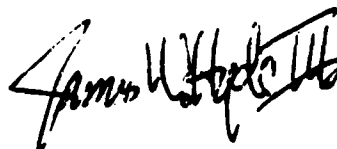

JAMES W. HYDE III
Directorate of Plans & Programs

If your address has changed or if you wish to be removed from the RADC mailing list, or if the addressee is no longer employed by your organization, please notify RADC (DCLD) Griffiss AFB NY 13441-5700. This will assist us in maintaining a current mailing list.

Do not return copies of this report unless contractual obligations or notices on a specific document require that it be returned.

UNCLASSIFIED

SECURITY CLASSIFICATION OF THIS PAGE

REPORT DOCUMENTATION PAGE				Form Approved OMB No. 0704-0188	
1a. REPORT SECURITY CLASSIFICATION UNCLASSIFIED		1b. RESTRICTIVE MARKINGS N/A			
2a. SECURITY CLASSIFICATION AUTHORITY N/A		3. DISTRIBUTION/AVAILABILITY OF REPORT Approved for public release; distribution unlimited.			
2b. DECLASSIFICATION/DOWNGRADING SCHEDULE N/A		4. PERFORMING ORGANIZATION REPORT NUMBER(S) N/A			
6a. NAME OF PERFORMING ORGANIZATION RJO Enterprises, Inc		6b. OFFICE SYMBOL (If applicable)		5. MONITORING ORGANIZATION REPORT NUMBER(S) RADC-TR-89-170	
6c. ADDRESS (City, State, and ZIP Code) 81 Hartwell Ave Lexington MA 02173		7a. NAME OF MONITORING ORGANIZATION Rome Air Development Center (DCLD)			
6d. ADDRESS (City, State, and ZIP Code) Griffiss AFB NY 13441-5700		7b. ADDRESS (City, State, and ZIP Code) Griffiss AFB NY 13441-5700			
8a. NAME OF FUNDING/SPONSORING ORGANIZATION Rome Air Development Center		8b. OFFICE SYMBOL (If applicable) DCLD		9. PROCUREMENT INSTRUMENT IDENTIFICATION NUMBER F09603-87-G-0659	
8c. ADDRESS (City, State, and ZIP Code) Griffiss AFB NY 13441-5700		10. SOURCE OF FUNDING NUMBERS			
		PROGRAM ELEMENT NO NAVY/920B	PROJECT NO JDLO	TASK NO 20	WORK UNIT ACCESSION NO 01
11. TITLE (Include Security Classification) CONFIGURATION DEVELOPMENT FOR ROMENET					
12. PERSONAL AUTHOR(S) Lawrence Rbue					
13a. TYPE OF REPORT Final		13b. TIME COVERED FROM Oct 87 to Jan 88		14. DATE OF REPORT (Year, Month, Day) October 1989	
15. PAGE COUNT 40					
16. SUPPLEMENTARY NOTATION N/A					
17. COSATI CODES			18. SUBJECT TERMS (Continue on reverse if necessary and identify by block number)		
FIELD	GROUP	SUB-GROUP			
25	05		Packet Switching, Communication Networks, Testing		
14	02				
19. ABSTRACT (Continue on reverse if necessary and identify by block number) A detailed Network Design Plan which specified the architecture and facility engineering required to implement a scaled Defense Data Network was prepared under this effort. It included a requirements analysis and detailed diagrams showing all major network elements, topology, functions and relationships. The output of this effort will be published as procurement information as each of the associated tasks are initiated.					
20. DISTRIBUTION/AVAILABILITY OF ABSTRACT <input checked="" type="checkbox"/> UNCLASSIFIED/UNLIMITED <input type="checkbox"/> SAME AS RPT <input type="checkbox"/> OTC USERS			21. ABSTRACT SECURITY CLASSIFICATION UNCLASSIFIED		
22a. NAME OF RESPONSIBLE INDIVIDUAL John B. Evarowsky			22b. TELEPHONE (Include Area Code) (315) 330-7751		22c. OFFICE SYMBOL RADC (DCLD)

DD Form 1473, JUN 86

Previous editions are obsolete.

SECURITY CLASSIFICATION OF THIS PAGE

UNCLASSIFIED

EXECUTIVE SUMMARY

As the Air Force increases computer automation of decentralized, mission-effective strategic and tactical systems, the need for secure, robust, and accessible communications resources increases. At present, the Defense Data Network (DDN), a packet switched network, is the primary communications resource available to the Air Force.

The performance and management of packet networks under stress as well as their susceptibility and vulnerability to exploitation have not been fully evaluated under the increased, mission critical traffic loads that are expected. The ability of subnetworks around the world to internetwork must be assessed. Common transmission paths supporting voice, data, and message switching must be developed to provide redundant media paths in time of need.

The Rome Air Development Center's (RADC) Wide Area Networks (WAN) laboratory has identified the need for a scaled DDN testbed network to perform experimental analysis and simulation in these areas. A five node (4 stationary, 1 mobile) packet network testbed called ROMENET is being planned for implementation. ROMENET will be deployed in the RADC WAN laboratory with interconnection to various trunking media and subnetworks including testbeds at Mitre/Bedford and FLATBED at Langley AFB. ROMENET implementation is expected to be phased over three years.

Allocation For	
Project	<input checked="" type="checkbox"/>
DDN	<input type="checkbox"/>
Other	<input type="checkbox"/>
by	
Distribution /	
Availability Codes	
Dist	
A-1	

TABLE OF CONTENTS

	<u>Page</u>
EXECUTIVE SUMMARY.	i
TABLE OF CONTENTS.	ii
 SECTION 1 - INTRODUCTION	
1.1 BACKGROUND	1-1
1.2 SCOPE AND OBJECTIVE.	1-1
 SECTION 2 - REQUIREMENTS ANALYSIS	
2.1 GENERAL.	2-1
2.2 TACTICAL REQUIREMENTS.	2-1
2.3 NETWORK TECHNOLOGIES EXPERIMENTS	2-1
2.3.1 Internetworking.	2-2
2.3.2 <u>Voice/Data Integration</u>	2-2
2.4 NETWORK COMMUNICATION VULNERABILITY ASSESSMENT	2-2
 SECTION 3 - NETWORK ARCHITECTURE	
3.1 GENERAL.	3-1
3.2 PACKET SWITCHING NODES	3-2
3.3 HOSTS.	3-2
3.4 INTERFACES	3-3
3.5 PERIPHERALS.	3-3
 SECTION 4 - ROMENET CONFIGURATION	
4.1 ROMENET BLOCK DIAGRAM.	4-1
4.2 ROMENET PARTS LIST	4-2
 SECTION 5 - SITE ENGINEERING	
5.1 GENERAL.	5-1
5.2 PHYSICAL REQUIREMENTS.	5-1
5.3 FLOOR PLAN	5-2
 SECTION 6 - TEST AND ACCEPTANCE	
6.1 GENERAL.	6-1
6.2 INSTALLATION AND OPERATION	6-1
 SECTION 7 - PHASED IMPLEMENTATION OF ROMENET	
7.1 GENERAL.	7-1
7.2 EQUIPMENT ACQUISITION.	7-1
7.3 PERSONNEL.	7-2

TABLE OF CONTENTS (CONTINUED)

LIST OF APPENDICES

<u>Appendix</u>		<u>Page</u>
A	Response to RADC Concerns.	A-1
B	PSN Operational Test Checklist	B-1
C	MC-Host Operational Test Checklist	C-1

LIST OF ILLUSTRATIONS

<u>Figure</u>		<u>Page</u>
3-1	ROMENET Network Layout	3-1
4-1	ROMENET Patch Panel Configuration.	4-1
5-1	NEPA L5-30R Receptacle.	5-1
5-2	NEPA 5-15R Receptacle	5-1
5-3	ROMENET Floor Plan	5-2

LIST OF TABLES

<u>Table</u>		<u>Page</u>
4-1	ROMENET Parts List	4-3
7-1	ROMENET Implementation	7-1
7-1	ROMENET Personnel Requirements	7-2

SECTION 1

INTRODUCTION

1.1 BACKGROUND

This document presents a plan prepared by RJO Enterprises and BBN Communications Corporation (BBNCC) for the design of ROMENET, a DDN-like testbed for the Rome Air Development Center (RADC) Wide Area Networks (WAN) laboratory. ROMENET is intended to provide RADC with the ability to test and evaluate the performance and vulnerability of the Defense Data Network (DDN) technologies in support of specific Major Command programs and activities at RADC.

ROMENET will support experimentation with packet switched network technologies and includes facilities to analytically evaluate the performance of the network and its associated equipment and media. In addition, ROMENET will provide a simulation vehicle for controlled interference or jamming into the media for vulnerability assessment. Through interfaces with the RADC Battle Management Laboratory (BML), ROMENET will allow the Air Force to assess the restorative and performance characteristics of the network under stressed conditions. The closed environment of ROMENET makes it ideal for creating and testing routing algorithms and network control protocols.

RJO and BBN personnel have met with RADC engineers to discuss ROMENET objectives and associated network architecture. These meetings have been followed by configuration research, site engineering, and interviews with professional staff at BBN Labs, RADC, Mitre/Bedford, and Tactical Air Command Headquarters (TAC HQ), Langley AFB.

1.2 SCOPE AND OBJECTIVE

This plan describes current requirements defined for ROMENET implementation. These requirements have been used to specify a mini-DDN configuration needed for RADC experimentation. A proposed parts list for acquisition is provided and phased implementation strategy is suggested.

A draft of this document was presented at the ROMENET Design Plan meeting held on December 21, 1987. Several issues, identified as action items at this meeting, were addressed in a letter submitted by RJO on January 6, 1988. (See Appendix A.)

SECTION 2

REQUIREMENTS ANALYSIS

2.1 GENERAL

This section describes the technical requirements of the ROMENET testbed. Through interviews with members of RADC's Wide Area Networks group, three global areas of networking study were identified for ROMENET: Tactical Requirements, Network Technologies Experiments, and Communications Vulnerability Assessment (CVA). The following sections describe these areas.

2.2 TACTICAL REQUIREMENTS

The USAF uses leading edge computer-based technologies to automate weapon systems and related command and control activities. Such automation usually requires highly interactive communication between systems on both a local and wide area basis. Therefore, it is important to evaluate the robustness of proposed communication resources, such as the DDN, and mobile transmission platforms under mission conditions.

Two areas of networking study have been defined for support of the automated systems, which compose the Tactical Air Command System (TACS): 1) Multi-Level Security (MLS) and 2) communication requirements assessment for Automated Decision Aids. These efforts will develop security requirements for each theater of operations as well as determine the internetworking and interoperability strengths impacting the Tactical Scenario. ROMENET needs to provide a diverse array of configurations that allow testing of various media, internetworking, packet switching, security, and reconstitution.

TAC currently has two testbeds in operation; one is located at TAC HQ, Langley AFB; and the other is located at Mitre in Bedford, Massachusetts. The TAC HQ testbed is referred to as Force Level Automation Testbed (FLATBED). Interconnection of RADC's BML and these two testbeds over ROMENET's packet switched facilities will allow full scale evaluation of TAC aids.

2.3 NETWORK TECHNOLOGIES EXPERIMENTS

The RADC Wide Area Networks (WAN) laboratory has the ability to simulate and test telecommunications networks. The laboratory contains voice switches, a variety of analog and digital transmission media, computers, and test equipment to support network experiments. Once ROMENET is deployed in the laboratory, various network technologies tests will be conducted. Tests that have been defined include: internetworking and interoperability, voice/data integration, and routing.

2.3.1 Internetworking

Internetworking is the ability of heterogeneous networks and communications equipment to interoperate. The study of the behavior of internetwork protocols under mission stress as well as the development of protocols for internetwork management are of interest to the Services.

Presently, the United Kingdom and Australia have expressed interest in the testing of internetworking concepts. In this effort, a technical cooperation agreement called STP V has been made among the governments of Australia, Canada, New Zealand, the United Kingdom, and the United States. ROMENET will provide a prime closed system for studies in this area.

2.3.2 Voice/Data Integration

Limited transmission bandwidth has created the desire for the common management and allocation of resources among voice, data, and message networks. The need to accommodate all of this traffic on common transmission facilities has led to many commercial and military integration efforts including Integrated Services Digital Networking (ISDN). The ability of one network, such as a packet network, to use a voice, data, or message switched network as a restorative pathway is a key concept addressed under project Forecast II, PT-14 "Survivable Communications Networks".

RADC will study voice and data integration by testing an intelligent T1 multiplexer on the trunk side of a ROMENET packet switch. Experiments will be performed that transmit X.25 packets over idle voice/data channels in the T1 bitstream. This integration allows greater utilization of available bandwidth.

2.4 NETWORK COMMUNICATION VULNERABILITY ASSESSMENT

RADC is developing techniques in Communication Vulnerability Assessment (CVA). The network control protocols, developed for the DDN, may be vulnerable to disruption or CCM attacks by hostile forces. ROMENET experiments are needed to determine the effects of various trunk media attack activities, such as jamming, and to uncover and quantify these vulnerabilities. Since end-to-end encryption, such as BLACKER, will be used for DDN application, the interaction between exploitation activities and encryption techniques presents an additional area of study. Long term growth of the DDN to include various trunk media with different communications characteristics and potentials for exploitation will change DDN vulnerabilities in unknown ways. Threats to the DDN in the CVA areas of susceptibility, feasibility, accessibility, and interceptibility can be simulated on ROMENET.

SECTION 3

NETWORK ARCHITECTURE

3.1 GENERAL

Performance of the experiments cited in Section 2 will require a network configuration that allows testing of advanced routing algorithms as well as the behavior of the network under stress. A four node network is the minimum configuration that will allow alternate routing characteristics to be tested upon failure of a single node. The study of battlefield deployed switches and media under mission scenarios requires the acquisition and placement of a mobile node. Finally, the monitoring, control, and reconfiguration of the network must be established by a control center within the ROMENET architecture.

ROMENET will initially consist of four stationary and one mobile BBCC Packet Switching Nodes (PSN) and one BBCC C/7 Network Operations Center (NOC). The configuration is shown in Figure 3-1. All of the equipment, except the mobile PSN, will be housed in the RADC WAN laboratory. A communications platform, such as a van, will be used for the mobile PSN installation. Experiments centered on mobile network operations may require moving the C/7 NOC to the mobile platform. The topological design of the testbed can be varied to accommodate individual test requirements. In general, each PSN will be biconnected, as are those in the DDN. The C/7 NOC can be connected to any of the PSNs. A variety of transmission media can be used to interconnect the switches. A patch panel, which enables topology and media to be easily modified for each experiment, will be provided.

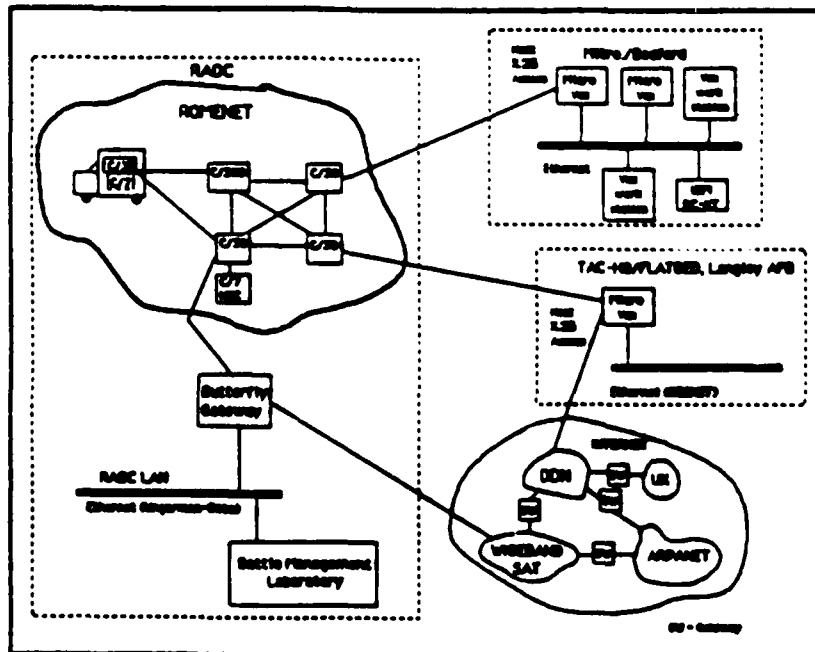

FIGURE 3-1 ROMENET NETWORK LAYOUT

The mobile PSN will allow remote testing with media such as radio and microwave. The RADC Local Area Network (LAN) will access ROMENET via the BBN Butterfly gateway currently located in the WAN lab. The FLATBED network at Langley AFB and the testbed at Mitre/Bedford will access ROMENET through X.25 host connections, which can be installed in Digital Equipment Corp (DEC) MicroVax computers residing in each testbed. As ROMENET matures, these host connections may be replaced with intelligent gateways.

3.2 PACKET SWITCHING NODES

The Packet Switching Nodes (PSNs) for ROMENET will contain switching components and operating software identical to DDN nodes. To reflect the smaller scale of ROMENET, the PSNs will not have a full population of I/O boards. There will be one C/3000, three C/30s and one C/3R PSN.

The C/30 is the primary PSN currently deployed in the DDN. The C/300 is a newer packet switch that contains a faster Central Processing Unit (CPU) and additional memory. All newly installed DDN nodes will be C/300s. The Defense Communications Agency (DCA) is currently upgrading many of the PSNs in the DDN to C/300s. The C/300 processes 900 packets per second and has a maximum of 64 total interfaces of which 14 interfaces may be trunks. The C/30 processes 400 packets per second and has a maximum of 44 total interfaces of which 14 interfaces may be trunks. Total interfaces include both hosts and trunks. While each PSN contains a different CPU, they are all microcoded to allow execution of the same instruction set. The C/30 is less expensive than the C/300 and is upgradable to a C/300. The C/3R is a ruggedized version of a smaller C/3 PSN that will be installed and tested in the communications vehicle. The C/3R has 12 host and trunk interfaces.

3.3 HOSTS

The host computers that will be connected to ROMENET have not been selected. With five PSNs, ROMENET will have the ability to connect many types of hosts. Pseudo-hosts will need to be added to ROMENET for simulation and traffic generation. ROMENET can use protocol analyzers, personal computers, or other test equipment to provide the X.25 data. The BBN PSN will transmit any host's data in X.25 or 1822 protocol.

Two of the hosts being considered for connection to ROMENET are the MicroVax at FLATBED and one of the host computers at Mitre. The MicroVax host at FLATBED is connected to a DECNET Ethernet LAN and the DDN. At Mitre, hosts are connected to an Ethernet LAN, which is not connected to the DDN. Hosts located at Mitre include MicroVaxs, MicroVax/GRX workstations, and IBM PC-XTs.

3.4 INTERFACES

The interfaces to ROMENET will be through hosts and gateways to other networks. An optional Terminal Access Controller (TAC) connected to ROMENET will allow the WAN laboratory technicians to communicate through the network without first logging on to a host.

Access to the network will be required for TAC HQ/FLATBED and Mitre/Bedford. The LAN at FLATBED may be connected to the network either through an interface board installed in the MicroVax at Langley or a gateway. A connection to FLATBED may also be established through the DDN. Mitre/Bedford may be connected to ROMENET through an interface board in a MicroVax or through a gateway. This plan proposes the use of X.25 host connections at each location. In addition, a connection to the RADC Command and Control laboratory will be needed. This connection may be made through the LAN at RADC or directly to the Command and Control laboratory. The Butterfly gateway in the WAN laboratory will provide communication paths to the Wideband Satellite Network and RADC's LAN. The Wideband Satellite Network is a part of the INTERNET, which consists of approximately 1000 interconnecting networks including the DDN, ARPANET, and UK packet networks. Figure 3-1 shows potential ROMENET interfaces.

3.5 PERIPHERALS

In addition to PSNs and gateways, ROMENET will be connected to network monitoring centers, test equipment, and transmission media. BBN's C/7 Network operations Center (NOC) will provide network management facilities for ROMENET. A C/7 will be connected to one of the four nodes in the WAN laboratory. The C/7 may be moved between the mobile communications platform and the laboratory as experiments require. The NOC will monitor and control, collect statistics, and report on the network. Both the test equipment and the transmission media will be determined by the experiment being run. The test equipment will consist of protocol analyzers, digital and analog line analyzers, and any other test equipment needed to complete a particular experiment. All connections to ROMENET will be made through patch panels to allow flexibility in the physical reconfiguration of the network.

SECTION 4

ROMENET CONFIGURATION

ROMENET's configuration was developed based on the network architecture described in Section 3. This section contains a block diagram that describes the physical layout of ROMENET as well as a parts list required for initial implementation.

4.1 ROMENET BLOCK DIAGRAM

A block diagram of the proposed ROMENET configuration is presented in Figure 4-1. This diagram shows the equipment connected to the patch panels. The PSNs and C/7 will be connected to RS-232 and RS-449 patch panels. Also connected to these digital patch panels are the Butterfly gateway, local hosts, and terminals. The remaining connections will be through the transmission media section of the patch panel that will be connected to transmission facilities. A separate analog patch panel should be provided for the testing and reallocation of analog facilities.

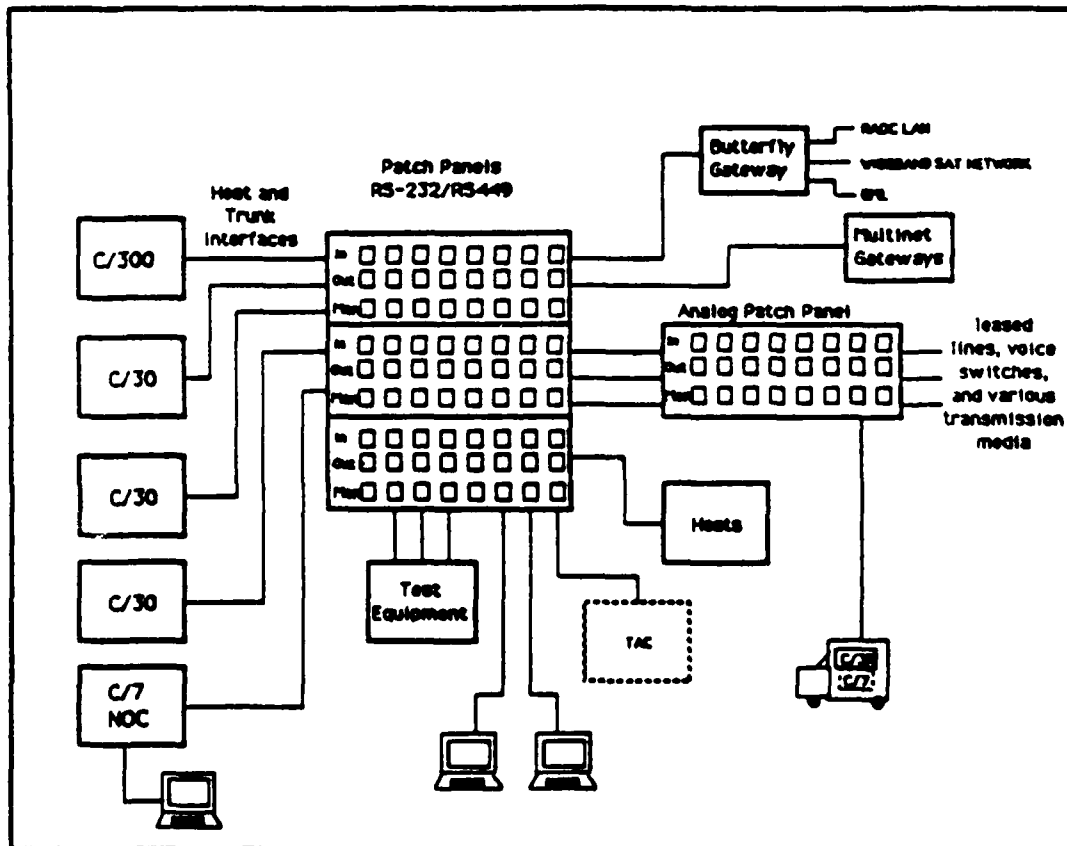

FIGURE 4-1 ROMENET PATCH PANEL CONFIGURATION

4.2 ROMENET PARTS LIST

Table 4-1 is a parts list for the proposed ROMENET configuration. The list is organized by equipment model. The first items listed are the C/30 PSNs and their accompanying hardware. All three C/30s will be equipped with identical hardware and capable of supporting a total of 26 host and trunk interfaces, with a maximum of 14 trunks. In addition to the processor board (MBP) and the memory board (MBN), each PSN will have two I/O boards, one MII and one MSYNC board. The MII will be fitted with four DIDF2 daughterboards, four MMB3 daughterboards and two MMR2 daughterboards. A DIDF2 board will support one 1822 Distant Host (DH) interface, while an MMB3 supports an RS-449 trunk and an MMR2 board supports an RS-232 trunk. The MSYNC board provides 16 host and trunk X.25 interfaces. Gateways are interfaced to the PSN using host ports. Two fantails will be provided with each PSN for interface of RS-449 and RS-232 trunks and hosts. BBN fantails are connected to the MII and MSYNC boards.

The C/300 configuration will be identical to the C/30 but will have two additional MSYNC boards. The additional MSYNC boards increase the maximum number of host and trunks supported to 74, although the restriction to a maximum of 14 trunk interfaces still applies. Two more fantails have been added to the list to support the additional trunks.

The C/3R supports 10 RS-232 and 2 RS-449, for a total of 12 host and trunk interfaces with a maximum of 12 trunks. There are no fantails or daughterboard options since the C/3R is delivered completely configured. The C/7 will provide a network management system for ROMENET. The C/7 includes a 340 MB Winchester (Fixed) Disk Drive and Controller and a Magnetic Tape Drive and Controller. The C/7 NOC can be configured to support a maximum of 16 DDN PSN load units. ROMENET's configuration of five PSNs will have a PSN load unit value of 10.

Interface boards, installed in the MicroVaxs, or gateways will be required to communicate with TAC-HQ/FLATBED, Mitre/Bedford, and RADC Command and Control laboratory. A B1822 interface card installed in the BBN Butterfly gateway, which is located in the WAN laboratory, will provide a communications link to the RADC LAN and the Wideband Satellite Network, which is a subnetwork of the INTERNET.

Over 150 RS-449, RS-232, and 1822 cables will be required to support the network. The parts list shows fewer cables since it is unlikely that 150 interfaces will be needed. In addition to the cables, a patch panel has been included. This patch panel will support both RS-232 and RS-449 interfaces and will provide the laboratory with flexibility in the physical reconfiguration of ROMENET.

Additional peripherals listed include 2 terminals and the NOC workstation. The terminals will be used for restarting a node without the use of the C/7 NOC. Texas Instruments 703 terminals are listed; however, any 300 baud RS-232 terminals will suffice. The NOC workstation is a color-graphics IBM PC/AT-based network monitor. The workstation is not essential to network operation but does provide a user-friendly operator interface to ROMENET.

**TABLE 4-1
ROMENET PARTS LIST**

Description	Part Number	Quantity
<u>C/30</u>		
C/30 with MSYNC 110V	C3120-4	3
MII board	5401-1	3
MMB3 RS-449 Daughterboard	5467-1	12
MRR2 RS-232 Daughterboard	5463-1	6
DIDF2 1822 DH Daughterboard	5442-1	12
8L-BAL/5405, RS-449, fantail	5457-2	3
8 unlocked RS-232, fantail	5453-2	3
<u>C/300</u>		
C/300 with MSYNC 110V	C3130-4	1
MII board	5401-1	1
MMB3 RS-449 Daughterboard	5467-1	4
MRR2 RS-232 Daughterboard	5463-1	2
DIDF2 1822 DH Daughterboard	5442-1	4
MSYNC I/O board	5405-1	2
8L-BAL/5405, RS-449, fantail	5457-2	4
8 unlocked RS-232, fantail	5453-2	2
<u>C/3R</u>		
C/3R, 10 RS-232, 2 RS-449	C3108-1	1
<u>C/7 NOC</u>		
C/7 Network Operations Center	C7171-1	1
*NOC workstation	6081-1	1
<u>OTHER</u>		
B1822 Butterfly Interface	1107874-01	1
ACC interface boards and software		2
*Texas Instrument 703 terminal	6080-1	2
1822 interface cable	5498-3	8
RS-449 cable		75
RS-232 cable		15
RS-232 patch panel		1
RS-449 patch panel		2
*Analog patch panel		1
*Protocol Analyzer		1
*Analog line tester		1
*Terminal Access Controller		1
*Optional		

SECTION 5

SITE ENGINEERING

5.1 GENERAL

ROMENET will be deployed in RADC's WAN laboratory. This laboratory is located in Building 3 at Griffiss Air Force Base, in Rome, New York. This section describes the physical requirements for the network, and provides a floor plan showing the location of the equipment in the laboratory.

5.2 PHYSICAL REQUIREMENTS

The RADC WAN laboratory meets the site requirements needed for ROMENET equipment installation. Since all BBN equipment is shipped in boxes not more than 63 inches high, 30 inches wide, and 38 inches deep, sufficient clearance should be provided at the loading dock and any doors leading to the laboratory. The floor must be strong enough to support the weight of the equipment. The single heaviest piece of equipment will be the 300 MB disk drive, which weighs 550 pounds (252 kg). All of the other equipment will weigh 200 pounds or less.

The RADC Wan Laboratory has a raised computer floor, which will provide room for cables as well as air conditioning. The air in the computer room should be maintained in a range of 10 to 32 degrees C. (50 to 90 degrees F.) and have a relative humidity of 20 to 80%, non-condensing.

The C/30s, C/300, and C/7 NOC will have a Power Distribution Unit (PDU) with a required power input of single-phased 90-135 VAC, 47-63 Hz. The receptacles for the PSNs will be NEMA L5-30Rs (see Figure 5-1). The C/7 will require two standard NEMA 5-15R receptacles (see Figure 5-2). All power outlets for the equipment should be three-wire outlets. The ground wires will run, uninterrupted, to the circuit box and be grounded to the building's metal frame. The ground bars in each cabinet will be tied together and connected to the AC ground of the system power supply, the cassette drive, and the power distribution unit. All national fire and electrical codes must be followed.

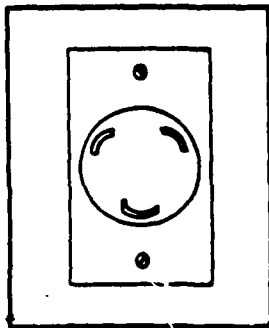

FIGURE 5-1 NEMA L5-30R RECEPTACLE

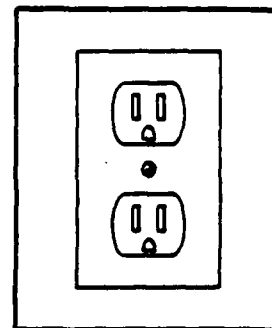

FIGURE 5-2 NEMA 5-15R RECEPTACLE

The mobile communications platform must have appropriate air conditioning and ventilation. The C/7 NOC and C3R PSN must be adequately secured with the C/7's hard disk locked when in transit. Properly grounded single-phased 90-135 VAC, 47-63 Hz power input must be available for the C/7 and C3R PSN. All the BBN equipment will be rack mounted in BBN-provided cabinets. The patch panels and gateways will require a separate cabinet.

5.3 FLOOR PLAN

The ROMENET equipment will be located in the northwest corner of the RADC VAN laboratory. Figure 5-3 shows a layout of the lab and the location of the equipment. The floor space required is approximately 144 inches by 100 inches. The equipment, itself, will occupy 144 inches by 30 inches of floor space; the additional space is required for opening cabinet doors for maintenance. The demarcation point of the network will be located on the wall directly behind the equipment.

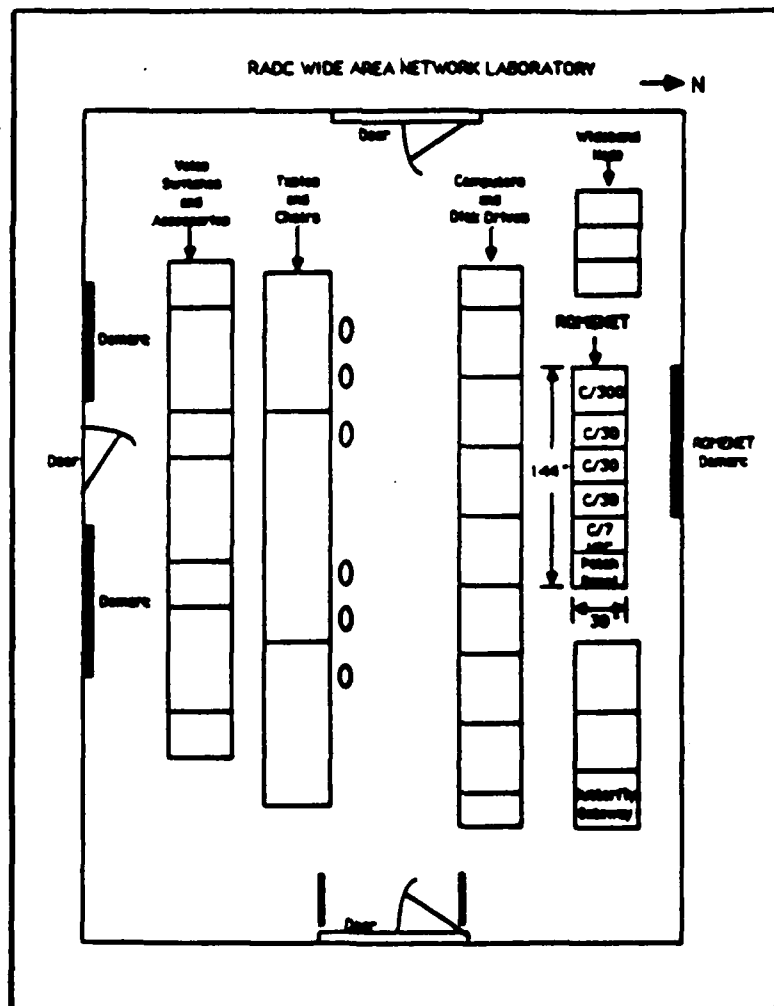

FIGURE 5-3 ROMENET Floor Plan

SECTION 6

TEST AND ACCEPTANCE PROCEDURES

6.1 GENERAL

The network test and acceptance procedures are based largely on BBN documentation. When the equipment arrives at the Wide Area Networks (WAN) laboratory and is unpacked, it should be inspected for damage. If there is any damage, an RJO representative should be contacted. The cabinets must be installed in the location identified in Section 5.3. All of the equipment must be installed according to site requirements listed in Section 5.2.

6.2 INSTALLATION AND OPERATION

The major steps in the installation and start-up operation of ROMENET are listed below:

1. Physically align, level, and secure all equipment. Connect cables.
2. Perform C/7 NOC start-up procedures:
 - a. Attach power;
 - b. Power-up;
 - c. Load and execute diagnostics;
 - d. Load operating system;
 - e. Start Network Utilities (NU);
 - f. Configure the network data base to include all nodes, trunks, gateways, and hosts; and
 - g. Start NETLOG.
3. Perform C/30 start-up procedures beginning with seed PSN (connected to NOC):
 - a. Attach power;
 - b. Power-up;
 - c. Load and execute stand-alone diagnostics;
 - d. Download software from C/7 NOC;
 - e. Start-up and test; and
 - f. NETLOG on NOC should report "node up".
4. Connect X.25 line analyzers and pass traffic.
5. Connect hosts (local then remote) and gateways.

Appendices A and B include operational checklists for the PSN and NOC that should be completed by a field engineer at the time of installation. Specific software loading instructions are provided in BBN documentation, "NU Installation Guide", BBNCC Report No. 5689. It is suggested that RADC assign one person as the data base administrator for ROMENET.

SECTION 7

PHASED IMPLEMENTATION OF ROMENET

7.1 GENERAL

ROMENET and associated experiments will mature and be implemented over a period of time. This section describes a phased implementation of ROMENET that would allow RADC to expand ROMENET over the next three years, as funding and personnel allow.

7.2 EQUIPMENT ACQUISITION

Phased implementation of the network is shown in Table 7-1. A minimum of 3 PSNs (2 C/30s, 1 C/3R) will be required to run TAC's experiments, test the mobile node, and perform network technology and CVA experiments. In addition, the Butterfly gateway interface board, X.25 boards for FLATBED and Mitre, and the leased lines needed to support these connections are required. A patch panel is included in the initial phase to provide easy reconfiguration of the equipment.

The acquisition of a C/300 in the second year and a C/30 in the third year completes the ROMENET configuration. The additional PSNs will allow more complex experimentation, involving alternative routing algorithms and CVA techniques, to be conducted.

TABLE 7-1

ROMENET IMPLEMENTATION

	Equipment	Quantity
1st YEAR	C/30 PSN	2
	C/3R PSN	1
	C/7 NOC	1
	Butterfly Interface Board	1
	ACC Interface Board and Software (For MicroVax host connections)	2
2nd YEAR	C/300 PSN	1
3rd YEAR	C/30 PSN	1

7.3 PERSONNEL

ROMENET will require three types of personnel support: operations, engineering, and systems programming. Operations support will be needed to run and maintain the network on a daily basis. Operations will also assist RADC in network testing. Engineering support will aid RADC in the full cycle of network operations including performance of network experiments. This support includes the development, implementation, and reporting of network studies. Programming staff will provide the ability to rewrite routing algorithms, network control routines, and protocols to suit the needs of each experiment. An estimated three year staffing plan is presented in Table 7-2. RADC must create an experimentation schedule before accurate personnel requirements can be provided.

TABLE 7-2

ROMENET PERSONNEL REQUIREMENTS

	Personnel	Manpower
1st YEAR		
	Network Operations	1.0
	Systems Programmer/Analyst	1.0 - 2.0
	Senior Engineer	1.0
2nd YEAR		
	Network Operations	1.0
	Systems Programmer/Analyst	2.0
	Senior Engineer	1.0
3rd YEAR		
	Network Operations	1.0
	Systems Programmer/Analyst	2.0
	Senior Engineer	1.0

APPENDIX A
Response to RADC Concerns

January 6, 1987

Mr. John Evanowsky
USAF/AFSC
Rome Air Development Center/DCLD
Griffiss AFB NY 13441-5700

Dear John:

At the December 21st ROMENET Design Plan meeting, you and John Salerno brought up four main concerns that were not adequately answered at that time. These were:

- 1) What are the specific differences between the standard DDN C/30 and the ROMENET C/30 configurations?
- 2) What are the costs for the DDN specified options?
- 3) What are the specific differences between the C/7 and C/70 NOCs? Can the C/7 be used for software development?
- 4) Will BEN provide source code and system programming support at RADC?

This memo is presented to you as a response to these outstanding issues.

1. DDN C/30 Vs. ROMENET C/30

Attached is a comparison matrix that compares the standard DDN C/30 configuration with the proposed ROMENET C/30 configuration. The DDN configuration includes a five-rack cabinet, which contains a rack for the C/30 and a 64 port TAC, two racks for the adapter chassis to support plug-in KG-84A cryptos, and two communication racks to support digital patch panels and telephone line terminator blocks for TAC-connected terminal lines.

Other than the additional racks and TAC, the C/30 itself is identical except for port configuration. Per RADC request, we have included RS232 ports as part of the port

allocation. Each PSN is equipped with 26 ports. Both systems run identical PSN software, which is currently release 6. Testing of release 7 is underway.

TEMPEST certified enclosures for the DDN C/30 are available.

2. Costs for DDN Options

The DDN equipment is priced through an IDIQ agreement between BBN and DCA. Specific options such as the crypto racks are not on the commercial price list for quotation to RJO. At this time, BBN is conducting negotiations with DCA and is unable to provide pricing information to RJO for this equipment. RADC may contact Lt. Col. Alan Maughn of DCA to obtain quotes on the DDN configuration. If you wish to acquire any of these options for ROMENET through RJO, I will request that BBN perform a custom cost quotation for those specific items.

3. C/1 Vs. C/10 NOC

The C/1 differs from the C/10 in three ways:

- a. The C/1 contains one 340 MB Winchester disk whereas the C/10 has two.
- b. Both systems run the same microcode and operating system. The network application software for the C/1 is limited to providing NOC services for 16 load units whereas, the C/10 will support larger networks with up to 160 BBN PSNs. A load unit is defined as follows:

C/3 PSN = 1 load unit
C/30 PSN = 2 load units
C/300 PSN = 3 load units

Hosts and circuits in a network are not counted as load units. The proposed ROMENET configuration requires a load unit capacity of 10. The load unit limitation is seen at the user level when using the DBEDIT command associated with the network database.

- c. The C/10 costs \$110,000 more than the C/1. The C/1 can easily be upgraded to a C/10 if RADC should require additional capacity.

The footprints of the C/1 and C/10 are identical. They possess the same computing power and run the same applications, such as software development and electronic mail. The C/1 is provided as an economical NOC for small networks.

C/7 Software Development

Until recently, BBN performed software development for the PSNs on C/70s. Currently, they use a combination of C/70s and VAXs, with the C/70 required for compilation. The C/70 and the C/7 come stock with basic development tools (e.g., compiler, editor, and debugger). Internal tools used by BBN are not supported; however, it is possible to acquire them for RADC use through contract negotiation.

The C/7 can be used for PSN software development. If the NOC application code is to be written on the C/7 for subsequent execution on a C/70, the load unit values would have to be set for the C/70.

4. BBN Software Development

After several discussions with BBN, it was determined that on-site software development using BBN PSN source code is negotiable. However, access and rights to the source code would be restricted to BBN personnel. It was expressed to RJO that such support will be costly and that RADC might prefer to have such development work done at BBN. On-line transfer of files over the DDN would be possible.

I hope that this memo has supplied answers that will allow you to make prudent technical decisions. I will call you to establish a conference call date that will allow you to suggest edits to the final ROMENET Design Plan and ask additional questions. In addition, I would like to discuss future business opportunities for RJO assistance to RADC with the ROMENET implementation. I have included an updated ROMENET parts list as an addendum to this document.

Professionally yours;

Larry Rhee
RJO - Boston
Telecommunications Group Manager

**TABLE 4-1
ROMNET PARTS LIST (REVISED 01/04/88)**

Description	Part Number	Quantity
<u>C/30</u>		
C/30 with MSYNC 110V	C3120-4	3
MII board	5401-1	3
HMB3 RS-449 Daughterboard	5467-1	12
HMR2 RS-232 Daughterboard	5463-1	6
DIDF2 1822 DE Daughterboard	5442-1	12
8L-BAL/5405, RS-449, fantail	5457-2	3
8 unlocked RS-232, fantail	5453-2	3
<u>C/300</u>		
C/300 with MSYNC 110V	C3130-4	1
MII board	5401-1	1
HMB3 RS-449 Daughterboard	5467-1	4
HMR2 RS-232 Daughterboard	5463-1	2
DIDF2 1822 DE Daughterboard	5442-1	4
MSYNC I/O board	5405-1	2
8L-BAL/5405, RS-449, fantail	5457-2	4
8 unlocked RS-232, fantail	5453-2	2
<u>C/3R</u>		
C/3R, 10 RS-232, 2 RS-449	C3108-1	1
<u>C/7 NOC</u>		
C/7 Network Operations Center	C7171-1	1
*NOC workstation	6081-1	1
<u>OTHER</u>		
B1822 Butterfly Interface	1107874-01	1
ACC interface boards and software		2
*Texas Instrument 703 terminal	6080-1	2
1822 interface cable	5498-3	8
RS-449 cable		75
RS-232 cable		15
RS-232 patch panel		1
RS-449 patch panel		2
*Analog patch panel		1
*Protocol Analyzer		1
*Analog line tester		1
*Terminal Access Controller		1
*Optional		

APPENDIX B
PSN OPERATIONAL TEST CHECKLIST

PSN OPERATIONAL TEST CHECKLIST

Date: _____ Network: _____
 MC Operator: _____ PSN Number: _____
 Site Name: _____ C/30 S/W: _____
 Work Order #: _____

1. Start time of tests: _____
2. Reload request trap reported by neighboring PSN. _____
3. Load the PSN. _____
4. PSN reports up on NETLOG _____
5. Monitor modem loops set up by Field Engineer, record whether line is looped (y/n).

Modem _____	Looped _____	Modem _____	Looped _____
Modem _____	Looped _____	Modem _____	Looped _____
Modem _____	Looped _____	Modem _____	Looped _____
Modem _____	Looped _____	Modem _____	Looped _____
6. Request Field Engineer unloop all modems. _____
7. For each host, run NITEST, and record the type of loopback used (F = external at fantail, NN = node modem, NH = host modem, NE = node ECU, HE = host ECU). For 1822 hosts record the NITEST results (number of error free bytes) in data field.

Host _____	Loop _____	Data _____	Host _____	Loop _____	Data _____
Host _____	Loop _____	Data _____	Host _____	Loop _____	Data _____
Host _____	Loop _____	Data _____	Host _____	Loop _____	Data _____
Host _____	Loop _____	Data _____	Host _____	Loop _____	Data _____
8. Unloop all host interfaces. _____
9. Completion time of tests: _____
10. Comments:

MC Operator Signature _____

APPENDIX C
MC-HOST OPERATIONAL TEST CHECKLIST

NC-HOST OPERATIONAL TEST CHECKLIST

Date: _____ PSN Number: _____
Sys. Integrator: _____ PSN Port: _____
C/70 s/n: _____ Network: _____
Work Order # _____

1. Login to C/70:
Telnet back to NC-host. _____
Turn on NU. _____
Turn on netlog. _____
Turn on ltbody. _____
2. Databases:
Display data block for host, line, and node. _____
Display lines. _____
Enter dcredit and change node name. _____
Reject exit. _____
Correct exit. _____
Enter dcredit and change TAC name. _____
Exit and display new names. _____
Change back to correct names. _____
3. TAC Editing:
Enter tacedit and display port config. _____
List ports. _____
Change data rate. _____
Display change, and quit. _____
4. Throughput Report:
Generate report. _____
5. Status Report:
Generate report. _____
6. Notes:

Tested by: _____
System Integration Engineer