

1

Design Study of a Modular Gas-Cooled, Closed-Brayton  
Cycle Reactor for Marine Use.

by

RICHARD DARYL LANTZ

OFF THE BODY

B.S., United States Naval Academy  
(1980)

DTIC  
ELECTE  
OCT 12 1989  
S D D

SUBMITTED TO THE DEPARTMENT OF  
OCEAN ENGINEERING  
IN PARTIAL FULFILLMENT OF THE  
REQUIREMENTS OF THE DEGREES OF

NAVAL ENGINEER

and

MASTER OF SCIENCE IN NUCLEAR ENGINEERING

at the

MASSACHUSETTS INSTITUTE OF TECHNOLOGY

June 1989

© Richard Daryl Lantz, 1989. All rights reserved

The author hereby grants to M.I.T. and to the U.S. Government permission to reproduce and to distribute copies of this thesis document in whole or in part.

Signature of Author: Richard D Lantz  
Department of Ocean Engineering, May 12, 1989.

Certified by: Lawrence M Lidsky  
Lawrence M. Lidsky  
Professor, Department of Nuclear Engineering  
Thesis Supervisor

Certified by: A. Douglas Carmichael  
A. Douglas Carmichael  
Professor, Department of Ocean Engineering  
Thesis Reader

Accepted by: Al F Henry  
Allan Henry, Chairman  
Department Graduate Committee, Department of Nuclear Engineering

Accepted by: A. Douglas Carmichael  
A. Douglas Carmichael, Chairman  
Departmental Graduate Committee, Department of Ocean Engineering

DISTRIBUTION STATEMENT A  
Approved for public release  
Distribution Unlimited

89 10 10 139

Design Study of a Modular Gas-Cooled, Closed-Brayton  
Cycle Reactor for Marine Use.

by

Richard D. Lantz

Submitted to the Department of Ocean Engineering on 12 May 1989 in partial fulfillment of the requirements of the degrees of NAVAL ENGINEER and MASTER OF SCIENCE IN NUCLEAR ENGINEERING at the MASSACHUSETTS INSTITUTE OF TECHNOLOGY.

ABSTRACT

A conceptual design of a direct Brayton-cycle marine power plant is presented. The design is a modification of the commercial MGR-GT, as proposed by James Staudt, sized to produce 40,000 shaft horsepower (SHP) and 5 MW of ship service electrical power.

The requirements of a shipboard power plant are discussed and the design changes that must be made to the components of a commercial power plant in order to fit them into the demanding environment of a ship at sea are detailed.

The final design consists of an 80-MWth passively-safe pebble bed reactor with an outlet temperature of 850°C. The reactor powers two separate closed Brayton cycle power conversion loops operating at a compressor discharge pressure of 8.2 MPa. Other features of the system are compact highly efficient heat exchangers, an advanced integrated electric propulsion system using solid state power converters and frequency changers, magnetic bearings, and high speed generators, both helium and water cooled. These features combined to produce system efficiencies exceeding 45%.

Results show that the use of a direct cycle electric drive power plant for ship propulsion is an attractive alternative. The heat exchangers and rotating machinery can be made compact and light, but the direct use of the commercial reactor core is not viable because of weight and size. A small, fast spectrum core is one potential solution for the heat source if it can be produced within the constraints of passive safety. Also further work needs to be done to optimize the turbine-compressor-generator system.

Thesis Supervisor: Dr. Lawrence M. Lidsky,  
Title: Professor of Nuclear Engineering.

ACKNOWLEDGMENTS

The author wishes to express his gratitude to the United States Navy for the opportunity of pursuing the course of studies at M.I.T.

To Professor Lidsky my sincere appreciation for the support, guidance, and understanding during the work on this thesis, especially during the times when things were not proceeding very well.

Finally, my deepest appreciation and love to my wife, Kathy, and my daughter, Elizabeth, whose unflagging support and understanding made the long hours at the computer somewhat bearable.

Accession For	
NTIS CRA&I	<input checked="" type="checkbox"/>
DTIC TAB	<input type="checkbox"/>
Unannounced	<input type="checkbox"/>
Justification	
By	<i>pr [signature] form 50</i>
Distribution	
Availability Codes	
Dist	Avail and/or Special
<i>A-1</i>	

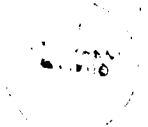

## Table of Contents

ACKNOWLEDGMENTS .....	3
Chapter 1 Introduction and Background .....	8
1.1 Introduction. ....	8
1.1.1 Previous work. ....	8
1.1.2 Marine Reactors. ....	11
1.1.3 Marine Environment. ....	14
1.2 MGR-GT. ....	16
1.3 Platforms. ....	21
Chapter 2 Requirements and Design Philosophy. ....	23
2.1 Design Philosophy. ....	23
2.2 Design Requirements. ....	24
Chapter 3 Brayton Cycle Analysis. ....	28
3.1 Method of analysis. ....	28
3.1.1 Cycle Selection. ....	28
3.1.2 Cycle analysis. ....	30
3.2 Results. ....	37
3.3 Nomenclature. ....	38
Chapter 4 Reactor Design. ....	39
4.1 Design Objectives and Considerations. ....	39
4.2 Fuel. ....	39
4.2.1 Fission Product Containment. ....	41
4.2.2 Mechanical Properties. ....	43
4.3 Core Type. ....	44
4.4 Reactor Safety .....	46
4.4.1 Loss of Coolant. ....	47
4.4.2 Shock Loading. ....	54
4.4.3 Water Ingress. ....	55
4.4.4 Primary Coolant Retention. ....	57
4.5 Core Size. ....	58
4.5.1 Criticality. ....	58
4.5.2 Core length. ....	60
4.6 Radiation Shielding. ....	61
4.7 Reactor Design Summary .....	62
Chapter 5 Mechanical Design. ....	66
5.1 Heat Exchanger Design. ....	66
5.1.1 Regenerator. ....	66
5.1.2 Precooler. ....	69
5.2 Bearing Design. ....	72
5.2.1 Magnetic Bearings Properties .....	72
5.3 Turbomachine design. ....	78
5.3.1 Baseline Turbomachine. [8] .....	78
5.3.2 Scaling Relationships. ....	79
5.3.3 Turbomachine Design Results. ....	80

Chapter 6 Electrical Design. ....	83
6.1 Design Considerations. ....	83
6.2 Integrated Electric Propulsion. ....	83
6.3 Generator. ....	86
6.3.1 Generator Cooling. ....	86
6.3.2 Propulsion Generator. ....	89
6.3.3 Ship Service Generator. ....	90
6.4 Propulsion Motor. ....	91
6.5 Power Conversion Equipment. ....	91
 Chapter 7 Control and Control Systems. ....	 93
7.1 Reactor Control. ....	93
7.2 Power Plant Control. ....	94
 Chapter 8 Design Summary. ....	 97
8.1 Reactor Compartment Arrangement. ....	97
8.2 Component Summary ....	101
8.3 Weight Summary. ....	104
 Chapter 9 Conclusions and Closing Remarks. ....	 105
9.1 Areas for Future Study. ....	106
 Bibliography ....	 108
Appendix A Heat Transfer Program. ....	110
A.1 Program Theory and User Guide. ....	110
A.2 Materials. ....	113
A.3 HEAT.BAS Input File. ....	118
A.4 Source Code Listing for HEAT.BAS ....	119
Appendix B Heat Exchanger Analysis. ....	128
B.1 Regenerator Design Program COMPHX.BAS ....	128
B.1.1 Method of Analysis. ....	129
B.1.2 Input file for COMPHX.BAS ....	135
B.1.3 Sample Output from COMPHX.BAS ....	137
B.1.4 Source Code Listing for COMPHX.BAS ....	138
B.2 Precooler Design Program PRECOOL.BAS. ....	158
B.2.1 Sample Output from PRECOOL.BAS ....	159
B.2.2 Source Code Listing for PRECOOL.BAS ....	160
 Appendix C Heat Exchanger Surfaces Characteristics. ....	 164
 Appendix D Heat Exchanger Surface Performance Data. ....	 166

## List of Figures

WANL concept 140,000 HP power plant. ....	9
Isometric view of WANL concept 25,000 HP power plant. ....	10
The MGR-GT in a below grade silo. ....	20
Efficiency comparison between Brayton cycle variations ....	29
Regenerated split shaft Brayton cycle. ....	32
Brayton cycle efficiency as a function of various parameters ....	34
Fuel pebble and TRISO fuel particle. ....	40
Coated particle failure fraction against temperature. ....	43
One-dimensional Marine MGR-GT Reactor Model. ....	50
Centerline Temperature after depressurized loss of flow. ....	51
Reactor radial temperature profile during LOCA. ....	53
Effect of power level on centerline temperature during LOCA. ....	54
Reactivity effect of water ingress on MGR-GT. ....	56
Section through Marine MGR-GT core. ....	63
Side view of the Marine MGR-GT reactor. ....	64
Radial magnetic bearing. ....	74
Axial Magnetic Bearing. ....	74
Basic arrangement of auxiliary bearings. ....	75
Active magnetic bearing control system. ....	76
Diagrammatic representation of inertial axis control. ....	77
Single shaft AIEP system single line diagram. ....	84
Historical generator power density trends. ....	88
Section view through reactor compartment. ....	98
Top view of marine MGR-GT reactor compartment. ....	99
Side profile of marine MGR-GT reactor compartment. ....	100
Thermal conductivity of reactor materials. ....	115
Specific heat of reactor materials. ....	116
Regenerator arrangement. ....	132
Plain-fin, plate-fin surface 46.45T. ....	166
Strip-fin, plate-fin surface 1/9-24.12. ....	167
Surface S 1.50-1.00, Staggered tube bank, plain tubes. ....	168
Surface s 1.50-1.25(s), staggered tube bank, plain tubes. ....	169
Finned circular tubes, surface CF-8.72(c). ....	170
Surface 8.0-3/8T, Finned circular tubes. ....	171

## List of Tables

Characteristics of the MGR-GT reactor heat source. ....	18
Possible Platforms. ....	21
Ship angles at which equipment must remain operational. ....	25
Initial Brayton cycle parameters. ....	30
Conditions at the Marine MGR-GT cycle locations. ....	37
Activity concentration in HTGR's. ....	41
Typical properties of Graphite-Matrix fuel compacts. ....	44
Initial temperature distribution and power density. ....	49
Initial core size estimates. ....	59
Marine MGR-GT reactor summary. ....	65
Reactor weight summary. ....	65
Regenerator performance results. ....	68
Input parameters for use in the Precooler design. ....	70
Precooler performance and sizing results. ....	71
Advantages of active magnetic bearings. ....	73
MGR-GT turbomachine characteristics. ....	78
Results of turbomachine scaling calculations. ....	80
Estimated characteristics of the marine MGR-GT turbomachines ....	82
Electric propulsion system benefits. ....	85
Design characteristics of the marine MGR-GT generators. ....	90
Design characteristics of the marine MGR-GT motor. ....	91
Power Converter Characteristics. ....	92
Reactor control system design considerations. ....	93
Speed-Time profile for naval vessels. ....	95
Marine MGR-GT Plant parameters and equipment summary. ....	103
Reactor compartment component weight summary. ....	104
List of material codes and materials in HEAT.BAS. ....	113
Sample input file for HEAT.BAS ....	118
HEAT.BAS source code listing. ....	119
Sample input file for COMPHX.BAS ....	136
Sample output from COMPHX.BAS. ....	137
COMPHX.BAS source code listing. ....	138
Sample output from PRECOOL.BAS. ....	159
PRECOOL.BAS source code listing. ....	160
Heat exchanger surfaces used in COMPHX.BAS. ....	164

## Chapter 1 Introduction and Background

### 1.1 Introduction.

This paper investigates the feasibility of using a modular gas-cooled closed Brayton-cycle gas turbine reactor as a power plant for naval vessels by developing a self-consistent prototype design. Although this concept has been studied for over twenty years, recent advances in fuel design, materials, components, an ever increasing amount of gas reactor experience, plus recent political and social attitude changes have shown that this system warrants renewed attention.

#### 1.1.1 Previous work.

The idea of using a closed Brayton cycle with a gas cooled reactor as the heat source is not a new idea. The closed-cycle gas turbine was first introduced in 1936 [8] and the idea of coupling it with a gas-cooled reactor was introduced soon after. It was considered by the navy as early as the early fifties, when the navy began design work on the USS Nautilus (SSN-571). The Nautilus was eventually powered by a pressurized water reactor. In 1974 the Westinghouse Astronuclear Laboratory (WANL) presented a design concept for a 140,000 SHP closed Brayton cycle plant.

Figure 1-1 shows the WANL concept. The concept used a closed Brayton cycle with helium as the working fluid. The core is a graphite moderated, epithermal spectrum reactor, using TRISO fuel particles in extruded graphite fuel elements. The fuel is highly enriched  $U^{235}$ . The containment is shaped in an inverted 'T' with two sections. The upper section contains the reactor core, control drums and the primary shield. The lower section contains two power conversion loops, each consisting of a turbine - compressor - heat exchanger package coupled to a superconducting generator. It also contains helium storage bottles, emergency cooling system, a fission product cleanup system, support structure, and second-

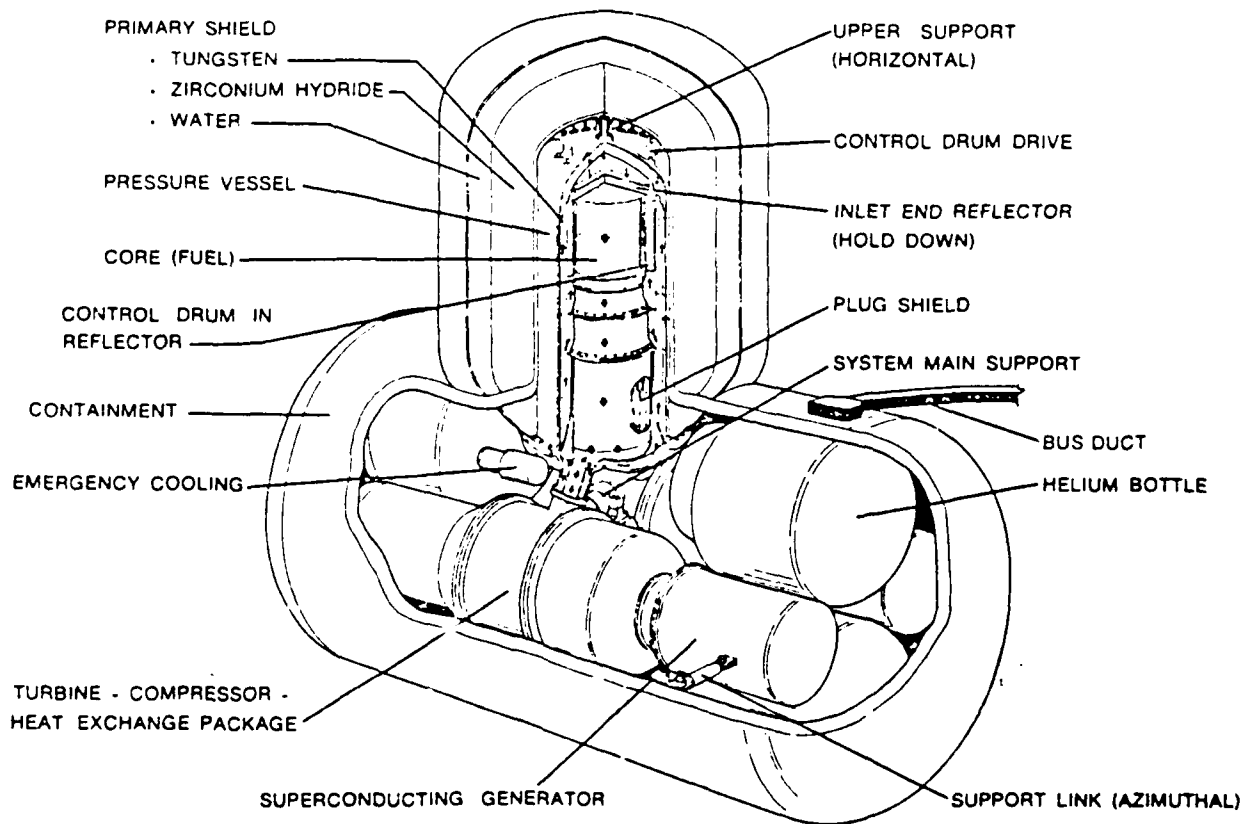

Figure 1-1. Isometric view of the WANL concept 140,000 HP Closed-Brayton cycle power plant. [4]

The priority of the WANL design was compactness. The entire unit is only 32 feet high, 18 feet wide, and 34 feet long. To achieve this compact design expensive shielding materials, and superconducting generators were used to arrange the plant as tightly as possible. With the compact shield and the highly power dense core, the plant cannot passively dissipate decay heat. This requires a quick reaction emergency cooling system to prevent core damage upon loss of cooling. Since water is not compatible with core materials, this emergency cooling system has to be gas based. Also, maintenance would be difficult because everything is packed so tightly together. Due to the high technical risk (along with

other factors) the WANL design was never funded, so development did not proceed.

During the same time frame WANL also designed a smaller (25,000 shaft horsepower) plant concept based on the NERVA reactor core. This concept is shown in Figure 1-2. The system is basically the same as the larger module except the containment arranged longitudinally instead of vertically. The system is direct drive with a single power conversion loop consisting of a turbine - compressor - heat exchanger package coupled to a reduction gear and propulsion shaft. Again, funding and development did not proceed.

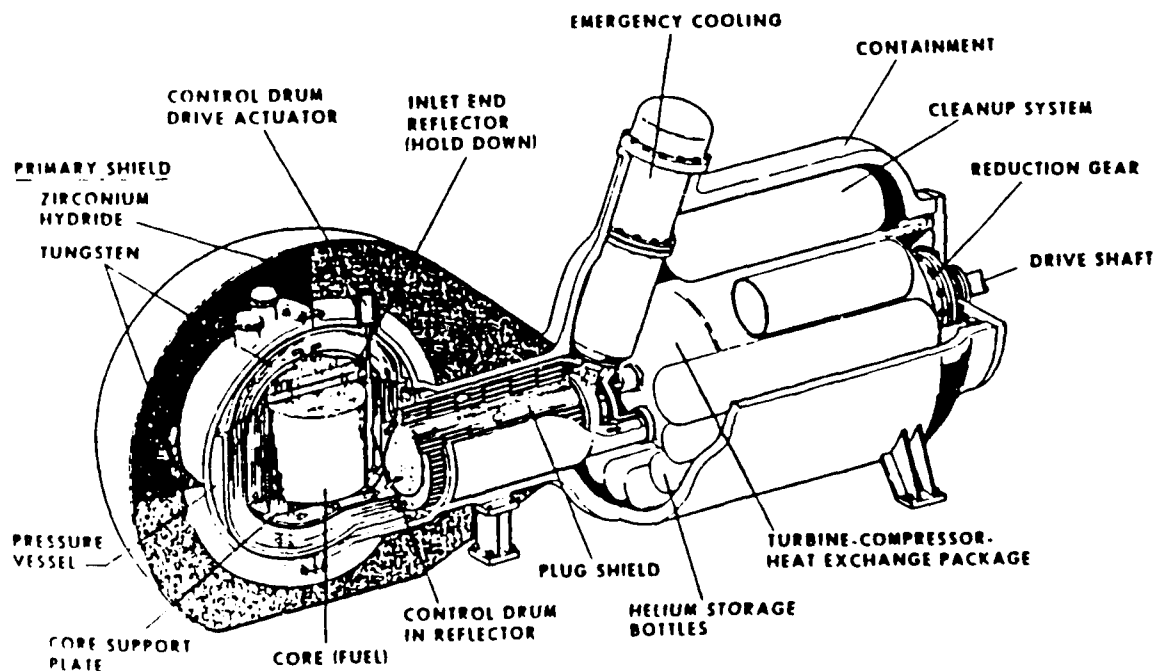

Figure 1-2. Isometric view of the WANL concept 25,000 HP Closed-Brayton cycle power plant. [4]

More recently, design studies of an MGR Brayton cycle power plant for commercial power generation have been conducted at MIT and in the United States and Germany. The Germans have acquired a wealth of experience in large closed-cycle gas turbines, having operated fossil fueled units since 1956. The largest, Oberhausen 2, operates at 50 MW(e)

and is a test facility for designing a large HGTR-GT. The German nuclear power industry has also operated large pebble bed reactors at the temperatures necessary to make the gas turbine economical.

In the United States there is only one commercial gas cooled reactor in operation, the 330-MWe Fort St. Vrain power station in Colorado. It is a nuclear steam system that has suffered many problems over its history. Many of the problems arising from water ingress into the helium coolant loop from the gas circulator bearings.

The General Atomic Company has conducted an extensive design study of a large direct Brayton cycle plant. Their design focused on a plant with a power level ranging from 800 to 1200 MWe with from two to four power conversion loops. All plant components were to be contained in a prestressed concrete reactor vessel. The program was terminated because of economic reason arising from the many technical problems which arose during the study.

The MIT design is for a smaller, modular plant. (See sect. 1.2) It is the MIT design that the design for this reactor will be based.

### 1.1.2 Marine Reactors.

Nuclear power has long been recognized as an ideal power source for naval vessels. Although there are many advantages, the principle benefit is elimination of refueling or battery charging. In general, surface ships carry enough fuel for five to six thousand miles at their most economical speed. Conventional submarines use a diesel engine to travel on the surface and batteries or some other air independent propulsion system when submerged. Non-nuclear submarines must carry both fuel and batteries, a double burden. The range of diesel submarines on the surface is about the same as a surface vessel, but current battery

technology limits the submerged endurance to a few hours. In order to achieve even this modest range, five to ten percent of total ship displacement is fuel and two to three percent of a submarine's weight is battery.

A nuclear power plant gives both surface ships and submarines virtually unlimited range, and it frees a large amount of space and weight that previously had to be devoted to fuel. Without the fuel load to consider, ships can be made smaller, or the same size ship could carry a larger payload.

Nuclear reactors have been used in marine propulsion since the USS Nautilus was launched in 1954. Since that day almost all submarines have been nuclear powered along with many large surface combatants. Smaller ships, such as frigates and destroyers, have not been nuclear powered. The pressurized water reactor is too big, too heavy, and too expensive to justify installation in the smaller ships.

In this country, the pressurized water reactor coupled to a Rankine power conversion cycle has been virtually the only nuclear power plant used to power ships. Although the PWR has been a proven, reliable power plant at sea for over thirty years, it suffers from the following problems which prevent nuclear power from reaching its full potential.

- **Low Thermal Efficiency.** Because of the difficulty of significantly superheating a PWR, Thermal efficiency is limited to around 30%. This low efficiency results in a great deal of latent heat being rejected to the sea. Besides the obvious energy waste, the heat wake generated by the waste heat could increase the detectability of the ship. To be fair, all thermal power plants reject most of their generated heat, but higher efficiency means more usable power for the same heat loss.
- **Large Component Size.** Due to the relatively low energy density of saturated steam, machinery, piping, turbines, and other steam system components are much larger than

in conventional superheated steam plant designs. This is a weight and volume penalty that reduces some of the benefits over fossil fueled ships gained by eliminating the fuel load.

- **Lack of Inherent Safety.** The U.S. nuclear power program has an undeniably excellent safety record. This is due to superb operator training, well engineered systems, and a management system that treats safety as the most important aspect of the operation. This is engineered safety, however, not inherent safety. The systems to ensure the engineered safety of the naval PWR can be five to ten percent of the reactor plant weight. An inherently safe system can possibly save some of this weight and space. All of the safety system weight and volume cannot be recovered since inherently safe nuclear systems generally are larger and heavier than similar systems in a standard reactor.
- **Heavy Weight Concentration.** The PWR is a high density system compared to non-nuclear ship systems. Heavy shielding, large pumps, thick pressure vessels and piping, combine to produce the heaviest single ship system besides the hull. This generally requires that it be placed low and in the center of the ship. This increases shielding requirements, and makes the ship more difficult to arrange.
- **High Maintenance Costs.** Radiological controls, safety graded systems, and intensive training makes maintenance expensive and time consuming.

An inherently safe closed Brayton cycle power plant has the potential to correct all of the above deficiencies.

### 1.1.3 Marine Environment.

There are many design differences between a reactor for ship propulsion and commercial power reactor used by utilities. Most of these differences are a result of their respective environments. The major environmental differences and their consequences are detailed below:

**MOTION:** A marine reactor is constantly subjected to the motion of the vessel it is installed upon. It is not uncommon for a vessel to experience roll motions up to 50 degrees from vertical at periods of 10 to 30 seconds. Pitch and heave accelerations can also become significant depending on the location in the ship. On the other hand, except during earthquakes, a commercial reactor can expect to have a stable platform for its entire operating life.

This motion has several design consequences. Foundations and structural members must be heavier and stronger to prevent lateral movement as well as provide vertical support. Since ocean forces are cyclic more attention must be paid to structural fatigue in those support members. Rotating machinery such as turbines, generators, etc. have to be oriented so that lateral bearing forces are reduced. This usually means that the large rotating machinery must be oriented fore and aft to reduce the effects of ship roll. Finally, components which require gravity for operation, such as control rods dropping by gravity in a scram, must take the motions of the ship into account in the design.

**SHOCK:** Because a naval vessel has to go in harms way, shock is an important design consideration. The shock forces and motions produced by a weapons explosion or a collision are fundamentally different from earthquake loads. Shock forces have a higher frequency and magnitude than earthquake forces but are of a shorter duration.

Shock has to be considered in every level of the design process. At the component level, individual components (electronics, turbines, foundations, etc.) have to be shock hard-

ened, while at the system level, the effects of shock induced motions and forces have to be considered in the arrangement of components, subsystems and the interfaces between those systems. It does not do any good to have shock hardened components if they bump into other components or tear out their connectors during a shock. The design consequences of shock are increased clearance between components, more and stronger support structures, and flexible connections. A full shock analysis is beyond the scope of this paper, however; qualitative shock considerations will be discussed where appropriate.

**Power Ramp.** A commercial power reactor lives in a very stable power environment. It is taken up to full power and, barring casualties or emergencies, it stays at a constant power level all the time. When power changes are required, they are done gradually and slowly. This is not the operating climate of a naval power plant. Even discounting emergencies, normal operations and maneuvering requires rapid and frequent power changes.

This necessity to change power level rapidly and safely impacts the design in several ways. The reactor control system has to be more extensive than a civilian design in order to control power peaking and allow rapid power level changes. This means more control rods and/or a large negative temperature coefficient. On the non-nuclear side of the plant, turbines and other equipment must be able to respond rapidly to power changes, meaning again, more and faster control systems (higher capacity throttle valves, or a larger inventory control system.) An energy storage system (such as a large steam drum) can be used to make power increase transients smoother at the reactor. The storage system supplies power to the ship until the reactor can catch up. Likewise, for a rapid decrease in power, energy has to be dumped until the reactor can be powered down.

**Corrosion.** Corrosion is a major concern in all power plant designs, commercial or marine. A marine reactor operates in the very corrosive environment of the sea. The power

plant itself is isolated from the sea and salt spray by the containment system so the corrosive effects of the surrounding environment on the design is minimal. Where the environment makes a difference is in the interface systems (heat exchangers and ventilation for example.) The corrosive environment affects the design in material selection for interface systems, and could require additional heat exchangers.

## 1.2 MGR-GT.

The marine power plant design is based on the design of the Modular Gas Reactor - Gas Turbine (MGR-GT) as proposed by Lidsky and Staudt of the MIT Reactor Innovation Program. [8] The MGR-GT is a system intended for commercial electricity production. The focus of this paper is to take the commercial MGR-GT, size it to meet shipboard requirements, and make any other changes necessary to adapt it to the harsh environment of a ship at sea. This section gives a brief description of the MGR-GT as a system. A more detailed description of individual parts will be in the chapters on that particular component. In the chapters that follow the components used in the MGR-GT will be used as the baseline for the marine version.

The following is a list of the design objectives of the MGR-GT design. [8]

- System placed in a below-grade silo.
- Flowpath permitting sweeping the reactor vessel with cool helium.
- Minimum machinery-module vessel size, and no larger than the reactor vessel.
- Flowpath maintaining low pressure difference across inner tube of concentric ducts.
- Flowpath that minimizes system pressure losses.
- Vertical turbomachine configuration, allowing easy access for machine removal from silo.

- Net turbomachine thrust in a direction opposite machine weight to minimize thrust-bearing load.
- All bearings in a low-temperature environment.
- Generator submerged in high-pressure, low-temperature helium.
- Plate-fin recuperator fins loaded in tension only.
- Easy access to heat exchangers, especially the precooler, for inspection and maintenance.

Figure 1-3 shows the layout of the MGR-GT in a below grade silo. The plant is in two steel pressure vessels connected by concentric cross-flow ducts. All power system components except electrical power conversion and distribution equipment are contained in the silos. Shown in the drawing are the core, pressure vessels, ducting, generators, turbine, compressor, regenerators, precooler, and the inventory control vessels.

The reactor heat source is a 200 MW pebble bed design using helium as a coolant.

Table 1-1 lists the reactor characteristics:

The MGR-GT is passively safe. It is designed so that the combination of a large negative temperature coefficient and the TRISO ceramic fuel enables the core to survive a total loss of coolant accident with failure to scram without damage to the core or release of fission products. The temperature coefficient rapidly shuts down the reactor while the small size allows generated heat to dissipate into the surrounding environment. [8]

The rest of the plant is a closed cycle gas turbine and associated equipment for control, start up, and electric power generation. The following gives a thumbnail sketch of the MGR-GT showing the major features

Table 1-1. Characteristics of the MGR-GT Reactor Heat Source.

Core Type	Pebble Bed cylindrical, graphite reflected on all sides
Power Level	200 MW(th)
Active Core Length	10 meters
Core Diameter	3 meters
Pressure Vessel Length	27 meters
Pressure Vessel Diameter	6 meters
Fuel Type	TRISO Coated Fuel Particles formed into 6 cm diameter spheres.
Enrichment	7%
Coolant	Helium
Reactor Exit Temperature	850°C
Moderator	Graphite
Refueling	Continuous

- The compressor, turbine, and generator are on a single shaft supported by active magnetic bearings. There are also auxiliary mechanical bearings used for start-ups and emergency landings.
- A highly effective plate-fin regenerator is used to increase cycle efficiency.
- A shell and tube precooler using fresh water on the cold side. The water will either be cooled in a cooling tower or by another water source such as a river or pool.
- The generator operates at a high rotational speed to reduce size and weight and is cooled by high pressure helium.
- A load commutated inverter system is used for electrical frequency conversion.
- Inventory control is used for normal power level changes with turbine bypass to the precooler available for emergencies and shutdown cooling.

- System pressure (compressor outlet) approximately 8 MPa.

Again, for a more detailed description of the individual systems see the chapter associated with the component.

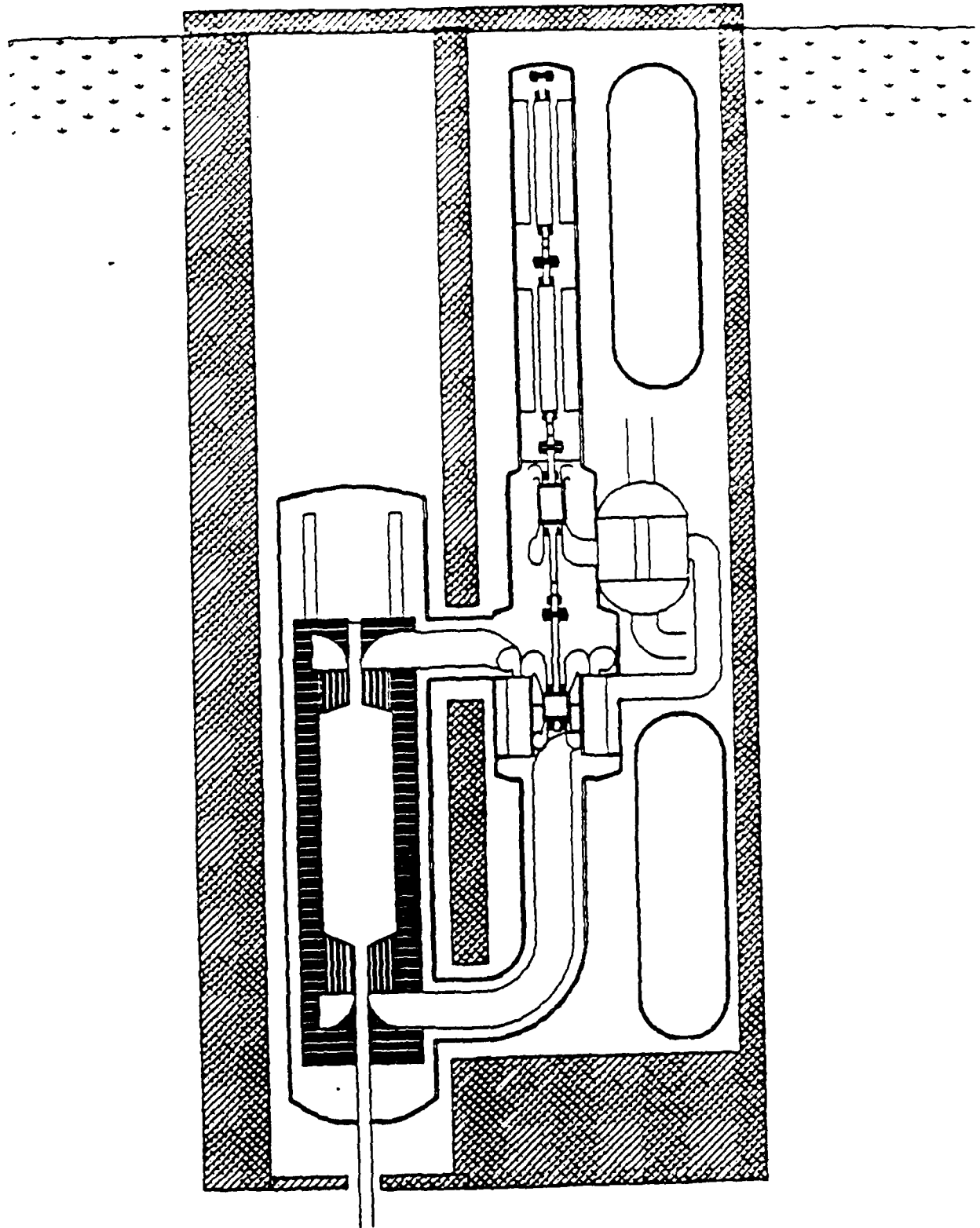

Figure 1-3. The MGR-GT in a below-grade silo [8]

### 1.3 Platforms.

This is to be a modular design that should find use in almost any naval vessel with little or no modification to the basic characteristics of the ship. This will set the desired power level and will determine the optimum size for the system. Table 1-2 lists various naval platforms and their requirements.

Platform	SHP	Shafts	SHP/Shaft	Power Level*	
				$\eta_r = .3$	$\eta_r = .5$
Aircraft Carrier (CV)	260000	4	65000	680	408
Battleship (BB)	212000	4	53000	555	333
Cruiser (CG)	80000	2	40000	209	125
Destroyer (DDG)	80000	2	40000	209	125
Submarine (SS)	30000	1	30000	79	48
Frigate (FFG)	40000	1	40000	105	63
Auxiliary	20000	1	20000	52	31

\* Power level is the required plant power level (in MW) of a thermal power plant at the thermal efficiencies shown. Note: This total does not include electrical power generation or power needed for aircraft operations.

In Table 1-2 SHP is shaft horsepower, Shafts is the number of propulsion shafts, and power level is the thermal power level required to produce the required SHP if the ship were nuclear powered. Of the above platforms only the carriers, cruisers, and submarines have nuclear powered variants. The power level is calculated from the SHP data from the following formula:

$$\text{Power level (MWth)} = \frac{\text{SHP}(7.457 \times 10^{-4})}{\eta_m \cdot \eta_r}$$

$\eta_m$   $\equiv$  Mechanical efficiency, accounts for the losses in the power transmission. It is also the ratio of power provided at the shaft to the power at the engine.  $\eta_m = .95$  is used for the above analysis.

$\eta_r$   $\equiv$  Thermal efficiency. Ratio of thermal power supplied by reactor to net work out. For PWR's  $\eta_r \equiv .30$

Based on the data in Table 1-2 a module size of 40000 SHP will be chosen. Using this size one module would be installed on frigates and submarines. Cruisers and destroyers will have two modules (one per shaft), while carriers and battleships would require 8 modules (two per shaft). The above result of one propulsion module per shaft for the smaller ships and two modules per shaft for the larger ships is the same as conventional designs. This is a convenient result since it means that if the reactor/engine room combination can be fit into the existing engine room volume of the smallest of the above ship types then the module design would fit into any ship. It would then simply be a matter of how many. In general, frigates and submarines have the smallest engine rooms for the installed shaft horsepower therefore the module design will be based on those ship types.

## Chapter 2 Requirements and Design Philosophy.

This chapter covers the design boundaries and the priorities used to optimize the plant and make decisions in the face of conflicting requirements. The first section details the design philosophy and priorities while the second section details the bounds of the design. By bounds I mean the performance requirements and engineering details that must be met in order for the power system to be considered a successful design.

### 2.1 Design Philosophy.

All large system designs are study in compromise. It would be nice if all one had to do to design the "best" system would be to pick the best components and put them together. This is not the case however, and a good system design often requires a loss of capability in one area in order to improve the whole. Priorities must be set in order to make intelligent decisions about design choices. The following lists the design priorities in their order of importance.

1. Safety.
2. Size.
3. Weight.
4. System Efficiency.
5. Technical Risk.
6. Cost.
7. Modularity.

In the design process the above priorities allow trade-offs to be made in a consistent and systematic manner.

## 2.2 Design Requirements.

Based on the requirements of the ocean environment, principles of naval architecture, and existing ship designs, the marine variant of the MGR power plant will be subject to the following design constraints:

**Design Standards.** U.S. Navy design standards will be adhered to for all components and systems. These specifications are spelled out in General Specifications for Ships (GEN-SPECS). GENSPECS includes Navy design standards for shock, roll, pitch, stability, and material quality among other things.

**Electric Drive.** Because of the difficulty in producing effective rotating shaft seals for high pressure helium systems, the system must be sealed. To accomplish this, the only product of the power system will be electricity. The ship use electric propulsion and auxiliary systems.

**Risk.** Where possible, "off the shelf" components will be used to reduce technical risk. Previous design work on high-temperature gas turbine reactors was never funded, partly because the design required significant research and development work on either components or materials in order to be viable. Using known technology will increase the chance that program development and deployment could be funded at a later date.

**Size.** The reactor and all associated support equipment must fit into the volume available in existing ships. In general this consists of the reactor compartment and engine rooms of existing PWR powered ships. Based on the machinery box sizes of the platforms in section 1.3 the volume envelope for a submarine will be a cylinder 10 m in diameter by 20 m long. A frigate module will be used to set the size of the surface ship module. A reasonable average for the machinery box of a frigate size ship would be 10 m high by 10 m wide by 20 m long.

**Safety.** The goal is passive safety, including safety during a core flooding accident. If passive safety should be unobtainable for all accidents then the plant should be passively safe for the majority of accidents, and additional safety systems as needed are to be included in the design to ensure safety in the other accidents.

**Modularity.** This is to be a modular design that will allow it to be included in almost any new construction naval vessel. Ideally the entire power generating plant (unfueled) would be able to be built off-site and transported to the shipbuilding site and installed within the vessel. The only difference between different ships would be the number of units installed. If the above is not feasible the module could be built into the ship using common components.

**Motion.** Table 2-1 gives the GENSPECS equipment motion qualifications. At the ship angles listed power plant equipment must remain fully operational. The requirements are different for surface ships and submarines.\*

Table 2-1. Ship angles at which equipment must remain operational. All angles in degrees. [9]

Condition	Submarines		Surface Ships
	Submerged	Surfaced	
Trim	30	7	5
List	15	15	15
Pitch	10	10	10
Roll	60	30	45

\*The requirements for aircraft carriers are less stringent than either submarines or other surface vessels, therefore plants which meet the above requirements will automatically be qualified for CVs.

In addition to the above, the plant must be able to survive a roll of 90 degrees. (ie. the equipment should be mounted so that it does not fall off its foundations if turned on its side momentarily).

**Containment.** The containment system must fully enclose all primary plant components. The main design goal is for the reactor compartment/engine room to be able to withstand the pressure of a primary loop rupture without venting to atmosphere or other ship's compartments.

**Refueling.** The degree of difficulty of refueling will determine the refueling cycle. It will be assumed that the core will not be continuously refueled for reasons listed elsewhere. If refueling is "difficult", i.e. requiring disassembly or cutting, the refueling cycle should be as long as possible, ten to twelve years with a minimum acceptable refueling cycle of four years\*. This would allow refueling to coincide with overhaul cycles. On the other hand if refueling is "easy", the refueling cycle can be reduced to one or two years.

**Power Requirements.** The power plant must be able to provide all power requirements of the ship. The power requirements of all U.S. naval vessels are as follows: 1) Propulsion; 2) Ships service electrical (60 Hz 3-phase); 3) 400 Hz ships service electrical.

**Enrichment.** There are no restrictions on enrichment except those dictated by other design constraints such as passive safety.

**Redundancy.** A high level of reliability is required for all vital components. Where possible, redundant components will be used to ensure adequate reliability. If redundancy is not possible (such as the reactor itself) the component must be made as reliable as possible

---

\*The minimum refueling interval is set by the four year minimum allowable time period between overhauls as specified by GENSPECS. Current maintenance philosophy is to perform major overhauls only when major equipment and system upgrades and conversions are needed.

and a backup system should be provided. Along with multiple redundant components the plant should be flexible enough so that the various components can be cross-connected to provide power in several configurations.

**Working Fluid.** Helium will be the working fluid of choice. In large commercial high-temperature reactors helium has proven to be the best working fluid. There are other possible working fluids, such as the other noble gasses, and their use will be discussed.

**Materials.** Material selection will be the same as the MGR-GT, unless investigation shows that a particular material is incompatible with the marine environment.

**Fuel.** TRISO ceramic fuel will be used. The final form (prismatic, pebble bed, particle bed, etc.), and enrichment is discussed later in the paper. This design decision effectively rules out using a fast spectrum core. Although a fast core has many attractive features (compact, high power density, long life, no reactivity increase with water ingress) the focus of this work will be the MGR-GT core. (See Chapter 4.)

**Temperatures & Pressures.** Temperatures and pressures at the controlling points in the cycle will be the same as in the MGR-GT. These are:

Turbine Inlet Temperature	850°C
Compressor Inlet Temperature	30°C
Compressor Discharge Pressure	8 MPa

## Chapter 3 Brayton Cycle Analysis.

This chapter details the methods and assumptions used to analyze the closed Brayton cycle portion of the power plant. The object of this analysis is to estimate the cycle parameters including temperature, pressure, mass flow rate, and overall cycle efficiency. Symbols used are listed in the nomenclature section at the end of this chapter.

### 3.1 Method of analysis.

#### 3.1.1 Cycle Selection.

There are many possible machinery arrangements possible for a closed Brayton cycle power plant. These range from simple, single shaft systems, to intercooled, regenerated, multiple shaft systems with several turbine-compressor pairs and separate power turbines. In general, all of these systems can be analyzed to a good level of accuracy by only three different variations of the simple cycle; regenerated, intercooled, or reheated. Each variation adds to the efficiency of the basic cycle in different ways.

The cycle chosen for this plant design is a regenerated cycle. This cycle combines good efficiency with the least complexity. This is shown graphically in Figure 3-1. The other cycles were rejected for various reasons. The reactor flow path for a cycle with reheat is complicated and difficult to achieve; therefore, it is not considered a viable alternative. The basic cycle is the simplest, requiring, the least equipment and cost. It is used extensively in aircraft and in open-cycle marine gas turbines, however; at the temperatures and pressures of this design the simple cycle has no significant efficiency advantage over current reactor designs. Intercooling alone does not increase effectiveness significantly over the basic cycle. In fact, at low pressure ratios, intercooling reduces cycle efficiency. The combination of intercooling and regeneration (ICR Cycle) does produce better efficiency than regeneration alone.

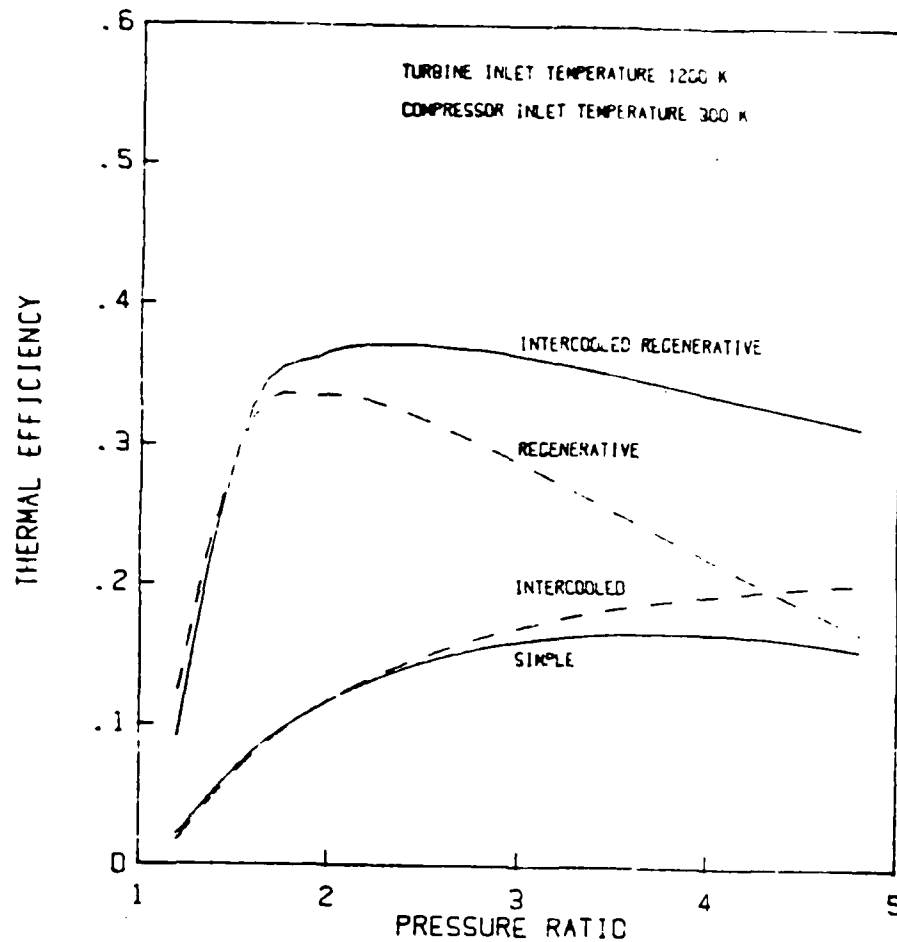

Figure 3-1. Effect of intercooling and regeneration on the thermal efficiency of closed Brayton cycles as a function of pressure ratio. [22]

In a sensitivity analysis performed by Staudt, he found that the ICR cycle was about 3% more efficient than a non-intercooled cycle at the pressure ratio for maximum efficiency (which for a regenerative cycle is about 2) and the pressures and temperatures of interest. This 3% increase in efficiency is bought at the cost of at least one more turbomachine and heat exchanger along with more ducting for each power conversion loop. As in the MGR-GT this modest improvement is not considered worth the additional complexity.

### 3.1.2 Cycle analysis.

Figures 3-2a and b show a recuperated Brayton cycle and defines the cycle points for this analysis. Each point in the cycle is defined uniquely by the pressure, temperature and mass flow rate,  $\dot{m}$ , at that point\*. The cycle analysis is performed by first defining known conditions at several points, along with the net power required and the performance efficiencies of the various components. This becomes an iterative process since the performance of components is often a function of the mass flow rate, temperature, and pressure.

Table 3-1 lists the set cycle parameters. They were chosen so that the cycle would resemble the MGR-GT as much as possible. The differences between the cycles are due to the lower power requirement of the marine version, plus the marine power plant has two power conversion loops per reactor while the MGR-GT has only one.

Table 3-1. Initial Brayton cycle parameters and set points.

Net Power Output per loop ( $W_{net}$ )	18.6 MW
Compressor Discharge pressure (P2)	8.2 MPa
Compressor Inlet temperature (P1)	30 °C
Turbine Inlet Temperature (T4)	850 °C
Compressor pressure ratio (r)	2.05
Recuperator effectiveness ( $\epsilon$ )	0.95
Turbine polytropic efficiency ( $\eta_{pt}$ )	0.90
Compressor polytropic efficiency ( $\eta_{pc}$ )	0.90
Generator efficiency ( $\eta_g$ )	0.98
Motor efficiency ( $\eta_m$ )	0.95

\* Since helium can be treated as an ideal gas with constant specific heat,  $C_p$ , enthalpy (h) is directly proportional to absolute temperature (T) and is given by  $h = C_p T$ .

The reactor heat source will supply two identical CBC power generating loops. Each loop will provide half of total ship power requirements. Therefore each loop must provide 20,000 HP for propulsion and 2500 MW of ships service electrical load. Net Power ( $W_{net}$ ) is the power at the turbine shaft for each loop. Converting to watts, and accounting for the efficiency of the power transmission train gives  $W_{net}$ .

The pressures and temperatures in Table 3-1 were based on the MGR-GT. The pressure ratio ( $r$ ) and regenerator effectiveness were picked from Figure 3-3 which shows the pressure ratio for maximum efficiency based on relative pressure drop and recuperator effectiveness. The efficiencies,  $\eta_{pr}$  and  $\eta_{pc}$ , are somewhat lower than the efficiencies of well designed commercial turbomachines. The values chosen were conservative estimates of turbine and compressor efficiencies. [3]

Once the above set points are chosen, the cycle is analyzed point by point until the temperature and pressure at each point is known. Each cycle point can be related to other points in the system by a series of well known thermodynamic principles and equations. The equations that follow are based on the assumption that helium behaves as an ideal gas and all losses in the system are included in the component efficiencies and pressure drops.

**Point 1-2.** Adiabatic compression by the compressor. Points 1 and 2 are related by the work required by the compressor to produce the proper pressure ratio  $r$ .

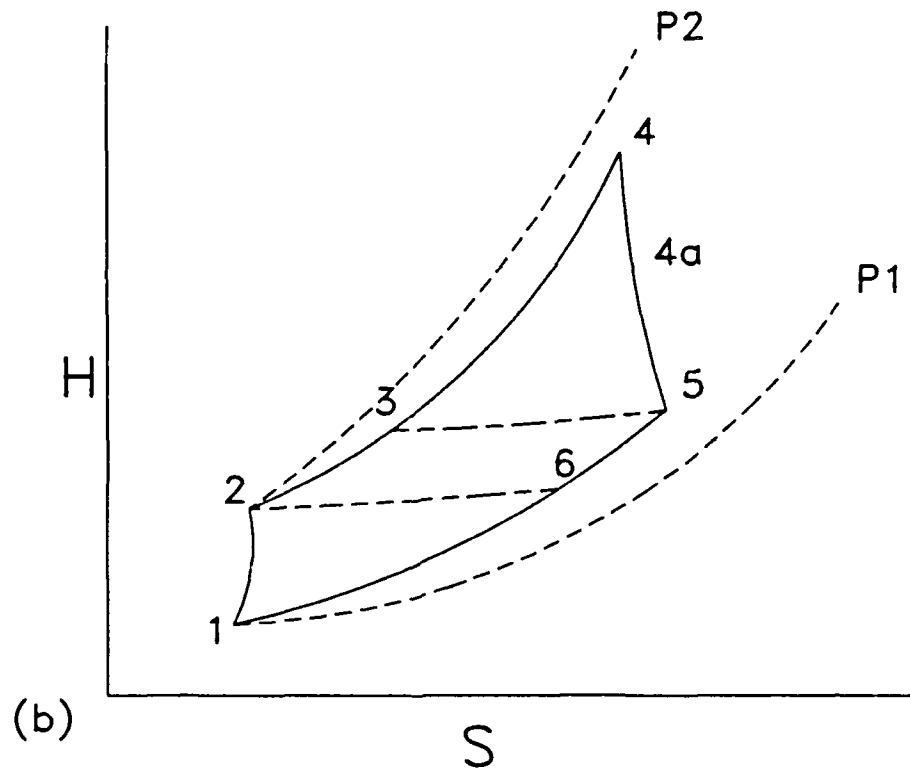
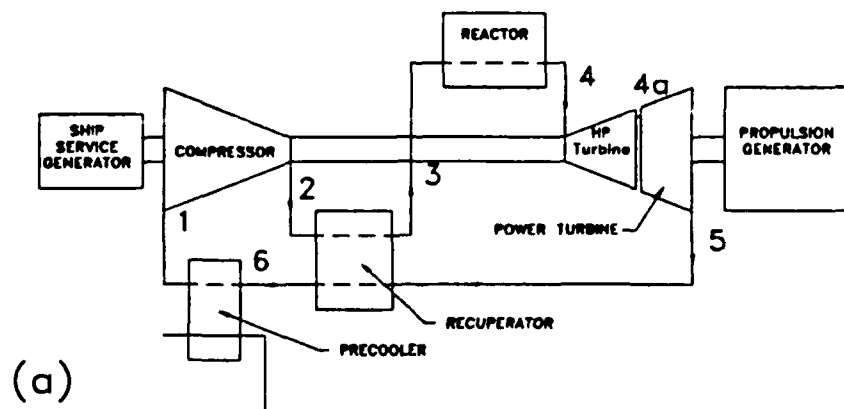

Figure 3-2. A recuperated Brayton cycle.  
 (a) Cycle diagram  
 (b) H-S diagram

$$r = \frac{P_2}{P_1} \quad 3-1.$$

$$\frac{T_2}{T_1} = r^{\frac{(\gamma-1)}{\gamma \eta_{pc}}} \quad 3-2.$$

$$W_c = C(T_1 - T_2) \quad 3-3.$$

$$C \equiv \dot{m}C_p$$

**Point 2-3.** Heat addition in the Recuperator. Energy from the turbine exhaust is used to preheat the compressor discharge helium. The amount of heat transferred depends on the effectiveness of the heat exchanger used. The relative pressure drop between 2 and 3 ( $\delta P_{rc}$ ) is also determined by the regenerator characteristics. Note that this particular cycle is highly regenerated. There is more heat added to the working fluid in the regenerator than in the reactor.

$$\epsilon = \frac{T_3 - T_2}{T_5 - T_2} = \frac{T_5 - T_6}{T_5 - T_2} \quad 3-4.$$

$$P_3 = P_2(1 - \delta P_{rc}) \quad 3-5.$$

**Point 3-4.** Heat addition in the Reactor core. All energy input to the system occurs at this point. There is also a pressure drop which is given by equation 3-7 below. [8] This equation uses a correlation for the core friction coefficient ( $\Psi$ ) which is dependent on the Reynolds number ( $Re$ ) and other directly measurable core characteristics (such as height, and pebble diameter) This pressure drop and the drop across the regenerators are one of the main

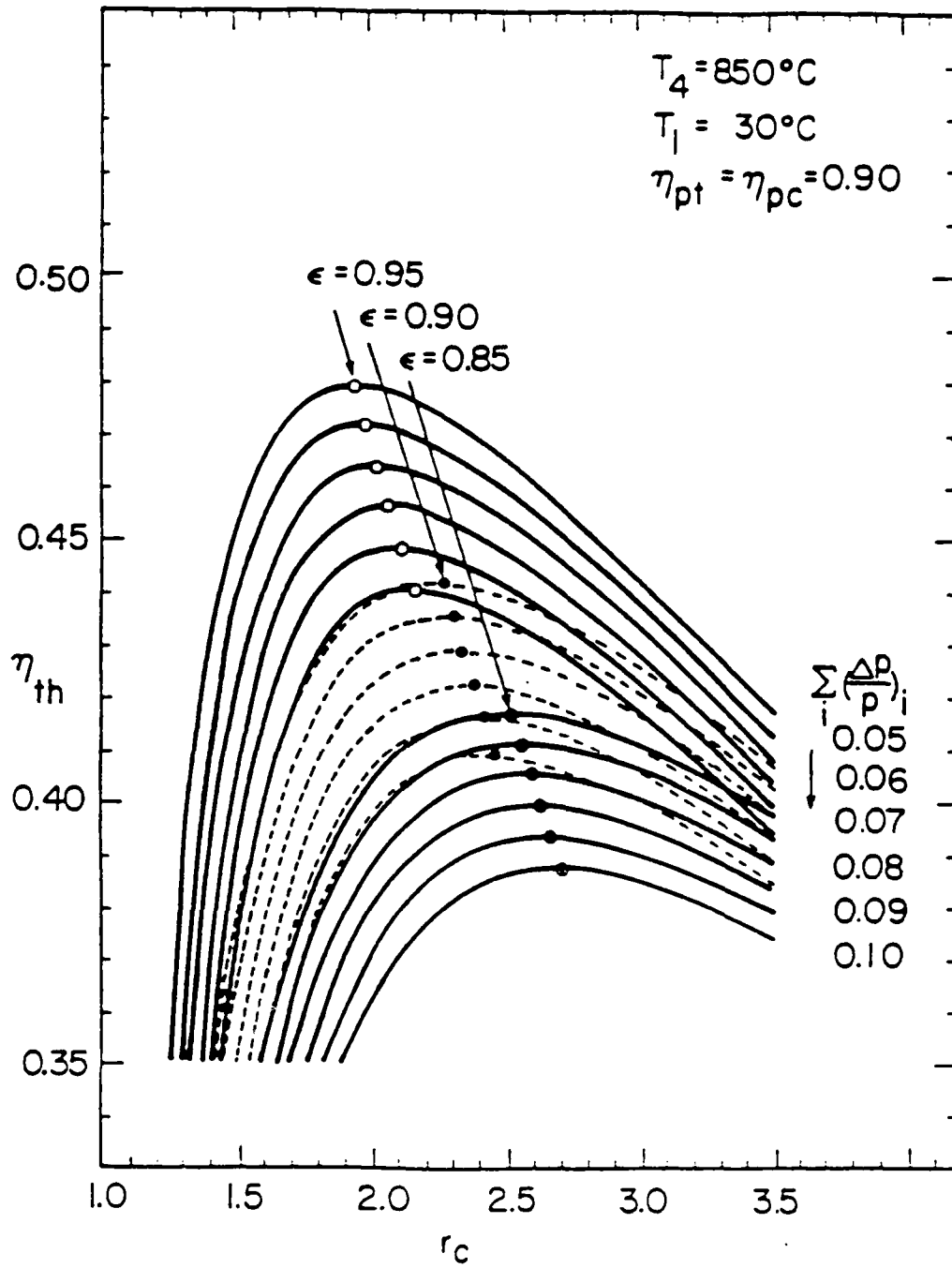

Figure 3-3. Brayton cycle efficiency as a function of pressure ratio, recuperator effectiveness and pressure loss. [8]

reasons to operate at high pressure. Not only does the heat transfer characteristics of helium improve at higher pressure but the relative pressure drop across components also drops as pressure is raised.

$$Q_r = C(T_4 - T_3) \quad 3-6.$$

$$\Delta P = \Psi \frac{\rho v^2}{2d_h} = \frac{9}{8} (133.3 + 3.663 \text{Re}^{0.905}) \frac{(1-\phi)^2 \mu H \bar{G}}{\phi^3 \rho d_k^2} \quad 3-7.$$

$$\text{Re} = \frac{G d_h}{\mu} = \frac{2}{3} \left( \frac{1}{1-\phi} \right) \left( \frac{\bar{G} d_k}{\mu} \right) \quad 3-8.$$

**Point 4-5.** Adiabatic Expansion through the turbine. Initially the presence of two turbines will be ignored to simplify the calculations. Cycle point 4a will be estimated later after points 4 and 5 are found. The above produces a very good estimate as long as the pressure drop between the exit of one turbine and the entrance of the other is negligible. The power produced by the turbines is exactly the energy (per second) removed from the helium between points 4 and 5. The work produced also has to equal the sum of the compressor work and the net power. The last requirement provides the iteration condition for the system of equations.

$$W_r = C(T_4 - T_5) = W_{net} + W_c \quad 3-9.$$

$$\frac{T_4}{T_5} = \left( \frac{P_4}{P_5} \right)^{\frac{(\gamma-1)}{\gamma} \eta_{pr}} \quad 3-10.$$

**Point 5-6.** Heat transfer in the regenerator. The temperature drop between points 5 and 6 will be the same as the temperature rise between points 2 and 3. The relative pressure drop across the hot side ( $\delta P_{rh}$ ) will not be the same as the cold side since the regenerator may have a different surfaces on each side and the pressure is lower. (See sect. 5.1 and App. B.)

$$P_5 = P_4(1 - \delta P_{rh}) \quad 3-11.$$

**Point 6-1.** Heat rejection to the environment. At this stage the helium is brought back to the initial temperature and pressure in the precooler, rejecting its latent heat in the process. The relative pressure reduction across the precooler ( $\delta P_{pc}$ ) is generally very small and is a function of the heat exchanger chosen.

$$Q_c = C(T_6 - T_1) \quad 3-12.$$

$$P_6 = P_1(1 + \delta P_{pc}) \quad 3-13.$$

To perform the analysis the above equations were programmed into a spreadsheet. Then initial guesses for mass flow rate, and heat exchanger pressure drops were entered. Because the system of equations is overdetermined, (more equations than unknowns) the spreadsheet calculated two different values for  $T_5$ . The mass flow rate was then adjusted up or down until the calculated values for  $T_5$  matched. When the two values match the system is consistent. Because the new calculated mass flow rate may not be the same as the mass flow rate used in the heat exchanger analysis program COMPHX.BAS (App. B), the heat exchanger analysis program is run again using the new cycle values and mass flow rate. This process is repeated until a stable solution is achieved. This usually took no more than 4 or 5 iterations. Once total turbine and compressor power are determined, the conditions at the power turbine inlet (point 4a) can be estimated by finding the helium conditions at the point where turbine work would equal compressor work plus ships service generator load.

### 3.2 Results.

Table 3-2 lists the results of the above calculations. It describes the expected helium conditions at the various points in the marine MGR-GT at full power with both power conversion loops on line. The effectiveness and pressure drops across the regenerator and pre-cooler were the values calculated using the heat exchanger analysis programs described in Appendix B. and the heat exchangers as described in section 5.1.

Table 3-2. Conditions at the Marine MGR-GT cycle locations.

<u>Point</u>	<u>Location</u>	<u>Temp (°C)</u>	<u>Press. (MPa)</u>
1	Compressor Inlet	30.0	4.00
2	Compressor Outlet	143.9	8.20
3	Reactor Inlet	582.5	8.13
4	Turbine Inlet	850.0	8.08
4a	Power Turbine Inlet	717.0	5.10
5	Turbine Outlet	605.6	4.09
6	Precooler Inlet	167.0	4.01
Helium mass flow rate		=	27.4 kg/s
Turbine Power			
	HP turbine	=	18.2 MW per side
	Power turbine	=	16.6
	Total Power	=	34.8
Compressor Power		=	16.2 MW per side
Cycle thermal efficiency		=	48.8%
Reactor Power Level		=	38.1 MW per side 76.2 MW total

## 3.3 Nomenclature.

<u>Symbol</u>	<u>Meaning</u>	<u>Units</u>
$d_h$	Hydraulic diameter	m
$d_k$	Fuel pebble diameter	m
H	Core Height	m
$\dot{m}$	Mass flow rate	kg/s
$C_p$	Specific heat	J/kg $\cdot$ K
G	Mass velocity based on flow area	kg/m <sup>2</sup> s
$\bar{G}$	Average mass velocity based on frontal area	kg/m <sup>2</sup> s
P	Pressure	Pa
T	Temperature	$^{\circ}$ K
Q	Heat flow (r-reactor,c-cooler)	W
W	Power (t-turbine,c-compressor)	W
$\Delta P$	Pressure drop across pebble bed core	Pa
$\rho$	Helium density	kg/m <sup>3</sup>
$\mu$	Dynamic viscosity	Pa s
Re	Reynolds number	
$\phi$	Core-void volume fraction	
$\Psi$	Core-friction coefficient	
$\epsilon$	Heat exchanger effectiveness	
$\delta P_x$	Relative pressure drop across a heat exchanger where in place of x: rc = Regenerator-cold side rh = Regenerator-hot side pc = Precooler	

## Chapter 4 Reactor Design.

This chapter details the reactor heat source design. Objectives are discussed first then fuel properties and choices followed by core structure and vessel design. Finally the final chosen design is summarized at the end of the chapter.

### 4.1 Design Objectives and Considerations.

The reactor heat source design follows closely the MGR-GT reactor design. Differences between the two reactors are made so the marine design follows the constraints and requirements listed in Chapter 2. As will be seen later, this decision prevented a detailed study of other possible heat sources. In particular a gas-cooled fast reactor was not considered at this time. Although a fast spectrum reactor has the potential to address many of the problems that will be discussed later, the focus of this investigation was to use the MGR-GT design as much as possible. The fast core will be the subject of future research. The MGR-GT reactor is a low-enrichment, graphite-moderated, thermal reactor. Modification of this design into a marine variant results in a large core.\* Attempts to make the core more compact, while still keeping within the design constraints from Chapter 2, proved to be very difficult. This is discussed in greater detail later in this chapter.

There were three major core design considerations: 1) maintain full passive safety; 2) minimize core size; and 3) use a proven fuel design, to minimize technical risk.

### 4.2 Fuel.

For a thermal helium-cooled reactor design, at the temperatures of interest, there does not seem to be a better choice than TRISO based fuel. TRISO fuel consists of micro-grains of fissile material surrounded by layers of refractory ceramic material. Figure 4-1 shows a

---

\* Large in comparison to naval PWR reactor cores.

diagram of a TRISO fuel particle and how the particles are incorporated into a graphite matrix to form a fuel pebble. Since the particle-graphite matrix is an extrudable mixture it can be formed into almost any convenient shape, the most common being spheres, and hexagonal prisms. The prismatic fuel is formed with channels for coolant flow and control rods. The TRISO fuel can also be formed into a porous block with a very high effective surface area. This is the basis for a form of particle bed fuel used in the NERVA\* reactor design.

There is a large knowledge base associated with TRISO based fuel. In this country the Fort St. Vrain power plant uses prismatic fuel elements while in Germany the AVR, a small, 15 MWe, pebble bed plant, in operation since 1967, has operated with helium outlet temperatures as high as 950°C. This knowledge base makes TRISO fuel a low risk choice.

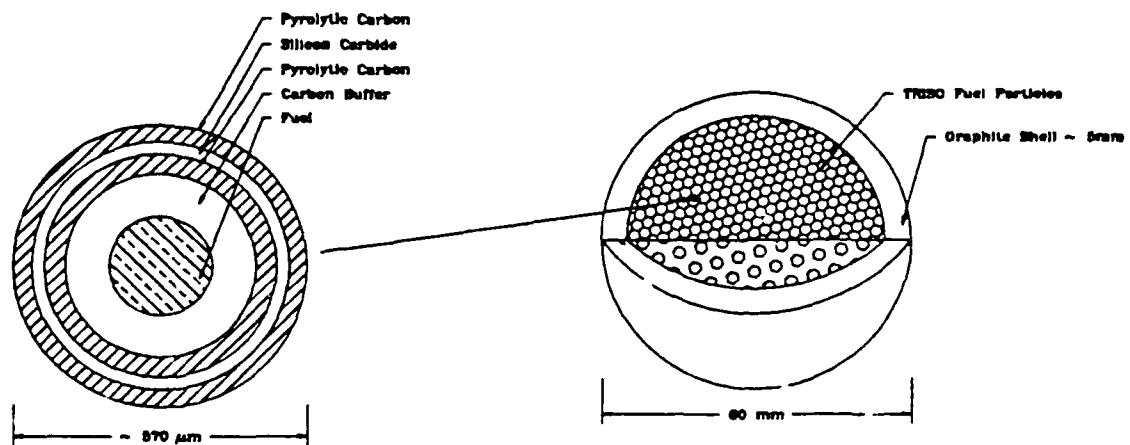

Figure 4-1. Fuel Pebble sectioned to show TRISO fuel particles embedded in a graphite matrix. A cross section of a fuel particle is shown on the left.

\* The NERVA (Nuclear Engine for Rocket Vehicle Application) reactor is a high power density reactor for space applications.

#### 4.2.1 Fission Product Containment.

With the TRISO coated fuel particles the two major parameters affecting fission product release is temperature and fuel quality. It has been determined that if fuel temperature remains below 1600°C there will not be significant fuel damage resulting in fission product release. This is shown in figure 4-2. Izenson [3] calculated that for a 200 MW pebble bed reactor with an outer radius of 3 meters, in an underground containment, peak fuel temperatures in the hottest region of the core did not exceed 1600°C during a depressurized loss of coolant accident (LOCA). This temperature is dependent on the heat transfer characteristics of the reactor structure and its ability to transfer heat to the ground through the containment. I confirmed this result with the marine MGR-GT design. (See section 4.4)

The other significant source of fission product release is defective fuel particles and entrained heavy metal atoms in the carbon layers outside the silicon diffusion layer. Given that the reactor does not operate at fuel temperatures above 1600°C, the defects are expected to be the major source of fission product release. [3] Any increase in fuel quality will decrease directly the circulating activity. Table 4-1 lists the circulating activity in current plants.

Table 4-1. Activity Concentration in HTGRs with TRISO fuel. Ci/m<sup>3</sup> [21]

Isotope or Class	AVR	FSV
Noble gases	$1.4 \times 10^{-2}$	$2.3 \times 10^{-1}$
Tritium	$3.0 \times 10^{-3}$	$5.0 \times 10^{-5}$
Si <sup>90</sup>	---	$5.0 \times 10^{-4}$
Ag <sup>110m</sup>	$2.8 \times 10^{-10}$	---
I <sup>131</sup>	$1.3 \times 10^{-10}$	$4.5 \times 10^{-4}$
Cs <sup>134</sup>	$8.0 \times 10^{-11}$	$3.8 \times 10^{-4}$
Cs <sup>137</sup>	$3.0 \times 10^{-11}$	$9.8 \times 10^{-4}$

The values for the AVR are probably more applicable since it uses higher quality fuel and has not had the water ingress problems of Fort St. Vrain. It should be noted that even the higher levels found at Fort St. Vrain are orders of magnitude less than water cooled plants.

Another possible avenue for fission product release is from particle damage from shock. Warships are subject to shock loading on occasion and it is important that the fuel remain intact when the ship is subject to shock loading (such as an explosion or collision.) Although the fuel compact may be damaged or broken by shock (see the next section) the real containment structure is the silicon carbide layer of the TRISO microsphere. This tiny layer is extremely tough and it is unlikely that any shock loading that the ship can survive would break microspheres in sufficient numbers to constitute a major release. Even though fission products are retained, if the fuel geometry were shattered the small particles (dust and small fragments) might be a very severe contamination source.

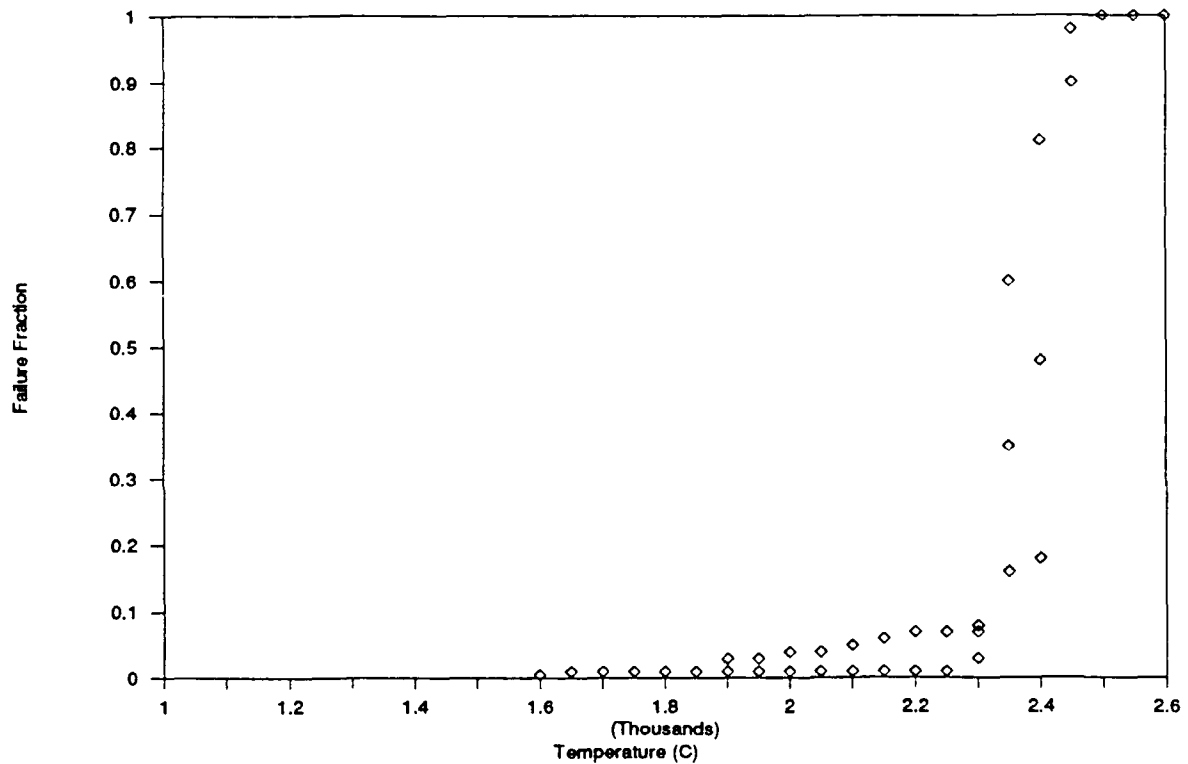

Figure 4-2. Coated particle integrity against temperature. [19]

#### 4.2.2 Mechanical Properties.

The graphite matrix fuel has very good mechanical properties for a reactor material. As listed in Table 4-2 it is dense, strong, chemically stable, and has a higher thermal conductivity than stainless steel. Although it is not strong enough to be used as structural material, it has good shock resistance. Pebbles manufactured for AVR and other pebble bed reactors must withstand a drop of 30 feet onto a steel floor without damage.

Table 4-2. Typical Properties of Graphite-Matrix Fuel Compacts. [14]

---

Graphite density	1.90 - 1.95 g/cm <sup>3</sup>
Crushing Strength*	8000 psi
Thermal Expansion (to 1000°C)	48.75x10 <sup>-6</sup> /°C
Thermal Conductivity (radial) at 2000°C	0.3 W/(cm <sup>2</sup> )(°C/cm)
Electrical resistivity	3.5x10 <sup>-3</sup> Ω-cm
Permeability (He @ 1 atm)	2x10 <sup>-3</sup> cm <sup>2</sup> /sec
Pore Structure	<1% of porosity due to pores > 1 μ in diameter
Radiation Stability	<0.1% contraction after 6x10 <sup>19</sup> fissions/cm <sup>3</sup> at 1100 - 1500°C

---

### 4.3 Core Type.

There are several types of core designs to consider. These are: 1) Pebble Bed; 2) Prismatic; 3) Particle Bed. All of the above use the proven TRISO coated fuel particles and have advantages and disadvantages which will be discussed briefly below.

#### 4.3.1 Pebble Bed.

The main advantage of the pebble bed core is refueling. The plant can be designed to be continuously refueled while on-line. With on line refueling there is a very low reactivity swing over the life of the plant. The fuel reaches a steady state level of burnup quickly after initial start-up. Although continuous, on-line refueling in a vessel at sea is not a good idea,\*\* the capability exists for a partial core exchange at sea or alongside a tender to reduce reactivity swing over lifetime. Even when on-line or partial refueling is not being used, a

---

\* Values for crushing strength and thermal expansion are average values. Both properties are dependent on grain orientation, which is not well defined in a spherical compact.

\*\* The fuel handling and storage equipment would add too much, weight, volume, and complexity to the plant design to be considered worthwhile.

pebble bed core can be refueled in batch without disassembly of the reactor. The refueling evolution could be as simple as opening a series of valves and letting the spent core drain out of the bottom of the reactor. The new core could be loaded just as easily. In reality, this would have to be a tightly controlled evolution since the spent core would be extremely radioactive. With proper procedures and equipment I believe that the pebble bed core could be loaded and unloaded without major disassembly of either the reactor or the ship and, in the case of submarines, the large pressure hull cut required to remove the core. Without major disassembly the evolution should be much quicker and easier than a conventional refueling. Assuming the above is true then the reactor need not be designed to go for long periods of time between refueling, thus less reactivity needs to be loaded into the core, simplifying the fuel design. Another advantage is that this type of core has been proven in operation in the two German reactors AVR and THTR, thus reducing risk.

The major disadvantage of this core type is a larger pressure drop across the core than either the prismatic or particle bed cores. However; as primary coolant pressure is increased the difference in pressure drop between the core types becomes less significant [8]

Another disadvantage is that the pebbles are "loose" inside the core. Because of the motions of the ship loose pebbles can be tossed about inside the core, damaging themselves and reflector material. This motion can be corrected by filling the core to the top and ensuring the pebbles are fully packed.

#### 4.3.2 Prismatic.

The prismatic core's main advantage is its lower pressure drop. Even though raising system pressure decreases the difference between core types, the loss is still less than an equivalent pebble bed. The prismatic core also is a proven technology having been used in the Fort St. Vrain reactor. The fuel elements are securely locked in place, thus making it

more resistant to ship motion than the pebble bed.

The major disadvantage of the prismatic core is in refueling. Because refueling requires at least partial disassembly of the reactor vessel, refueling would be a much more difficult evolution than in the pebble bed core. Because of this, the core would have to be designed to go at least eight, and preferably twelve years between refueling so that refueling would coincide with overhaul schedules. The excess reactivity that would have to be carried around to accomplish this would significantly affect the fuel design. The usual method employed to extend core life while keeping the core compact is to increase the enrichment and add burnable poisons. While there is no question that this could be done, it is unclear if it could be accomplished while still keeping the reactor safe from a core flooding accident. Further study is needed to answer this very important question.

#### 4.3.3 Particle Bed.

The particle bed core is a very attractive alternative, promising high power densities with a low pressure drop. It shares the major disadvantage of the prismatic core in that it requires partial disassembly to refuel. Its other disadvantage is that it is new technology and not yet a proven concept. A small, high-power-density, fast-spectrum particle bed core, has great potential.

### 4.4 Reactor Safety

Passive safety is the major design requirement for this reactor, and it turns out to be the limiting factor on enrichment, and thus core size. Although the plant could be designed for engineered safety, as PWR's are operated today, the safety equipment will add weight, volume, and complexity to the final system, all of which are to be avoided if possible in a ship design. Passive safety also makes sense from a public safety consideration and it would be politically more attractive, (thus increasing the probability of it getting funded). On the down

side passively safe cores are larger thus requiring larger pressure vessels and more shielding. The question is which weighs less or is smaller, a large safe core or a smaller core with installed safety equipment. With the above in mind safety issues must be addressed in the following areas: 1) Fission product containment during normal operation and accidents; 2) Reactivity insertion due to water ingress; 3) Primary coolant retention during a depressurization accident; 4) Radiation shielding of personnel. Fission product retention during normal operation discussed above. Accidents, water ingress, and shielding are discussed in the sections that follow.

#### 4.4.1 Loss of Coolant.

For most reactor plants a catastrophic loss of coolant accident (LOCA) is the basis event. In the commercial MGR-GT design this accident limits the average power density to 6 or 7 MW/m<sup>3</sup> and the radius is limited by the thermodynamic properties of the materials in the core and surroundings.

To investigate this design point in the marine variant I developed the program HEAT.BAS to perform a one-dimensional transient heat conduction analysis. The objective was to verify that the final core configuration would not exceed 1600°C during a LOCA. HEAT.BAS was written in QuickBASIC and runs on IBM style personal computers. It is fully described in Appendix A. along with a sample input file and source code.

##### 4.4.1.1 Problem Assumptions.

The following summarizes the assumptions used in modeling the reactor and initial conditions for the problem.

1. Surface of the shielding water tank remains at a constant 50°C. The shielding water tank is a large water filled tank which has both its own cooling system and is in direct thermal contact with the sea through the hull of the ship. Given the long time frame associated with the postulated accident, 50° is probably a conservative estimate.
2. No credit is taken for axial heat conduction, heat loss through the ends of the core, or any natural circulation of helium within the core. Again this assumption will produce a conservative estimate.
3. The power density, and initial temperature distribution will be the same as the MGR-GT since the core radius is approximately the same and the exit temperature is the same. The values used are given in Table 4-3. They represent the steady state conditions at full power at the axial position in the core where the highest temperature is reached after the casualty. This is approximately where  $z/H = .2$ ;  $z$  is distance from core entrance and  $H$  is core height. [7]
4. The volume fraction of pebbles is  $\frac{V_{\text{pebbles}}}{V_{\text{core}}} = 0.61$ .
5. The pebble diameter is 6 cm.
6. The pebble bed emissivity is 0.8 and the emissivity of outer surface of the core barrel, the outer and inner surface of the pressure vessel, and the inner surface of the shielding water tank is 0.6.
7. The accident is assumed to start at time 0 with depressurization of the reactor core. Any helium cooling due to expansion is ignored and the reactor power falls off according to the decay heat fraction (ie. the reactor trips at time 0 with the core at atmospheric pressure.)

Table 4-3. Initial power density and temperature distribution used in the transient accident analysis.

---

<u>Radius (m)</u>	<u>Temperature (°C)</u>	<u>Power Density (W/cc)</u>
0.05	582	8.21
0.1	580	8.15
0.2	579	8.10
0.4	572	7.60
0.5	565	7.30
0.6	560	7.25
0.7	552	7.24
0.8	544	6.80
0.9	542	6.67
1.01	539	7.33
1.06	538	7.00
1.12	537	6.87
1.24	536	6.90
1.30	531	3.00
1.35	530	0
1.45	425	0
1.55	320	0
1.57	310	0
1.77	200	0
1.80	185	0
1.85	170	0
1.87	50	0

---

8. All heat generation is in the active core, radiation heating in the reflector or vessels is not included.
9. Dimensions and materials used are shown in Figure 4-3.

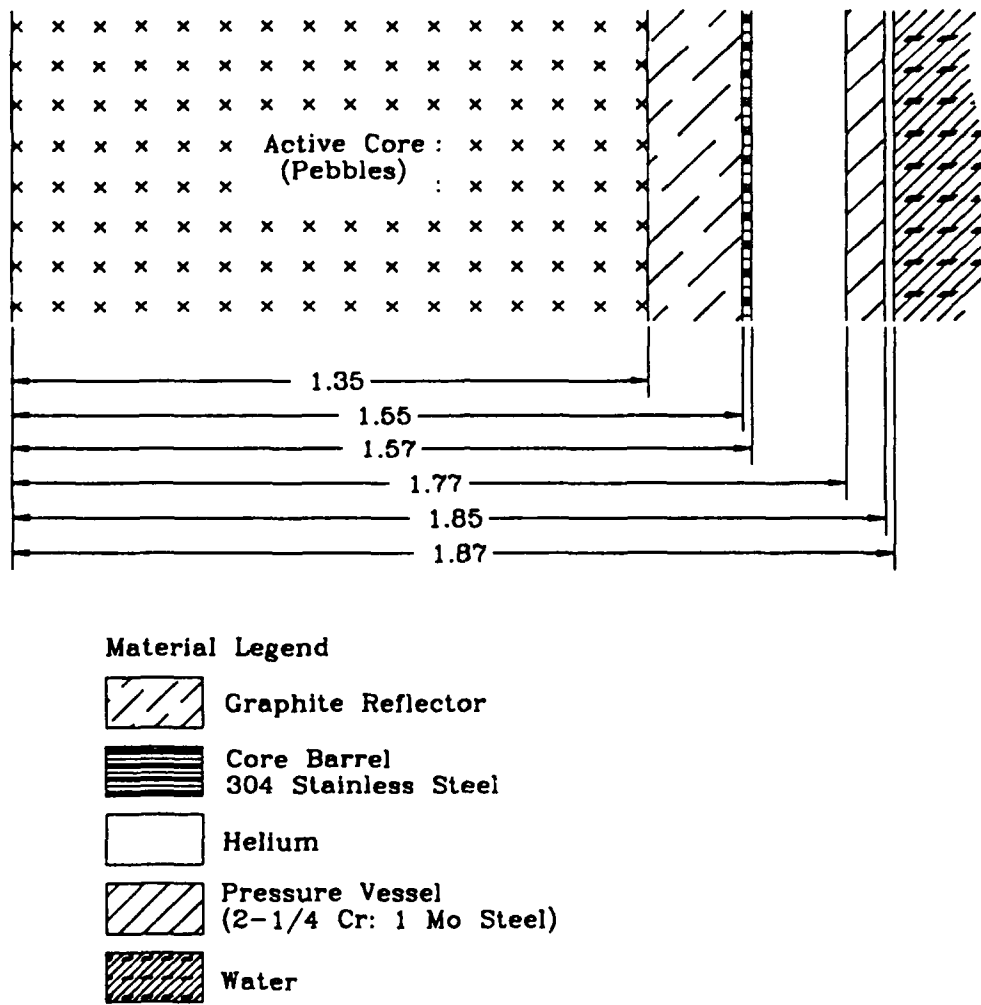

Figure 4-3. One-dimensional model for the Marine MGR-GT reactor showing dimensions and materials used.

4.4.1.2 Results.

HEAT.BAS was run using the above assumptions, dimensions, and materials. Figure 4-4 shows the centerline temperature plotted against time since event initiation. After the initial sharp temperature increase, the heat generation decays until heat rejection into the sur-

rounding water equals the heat addition. For the baseline case (linear heat generation rate = 39 MW/m) peak temperature reaches 1400°C at  $t=39$  hours. The temperature then gradually falls off, until at 100 hours after the event, centerline temperature drops to just under 1300°C.

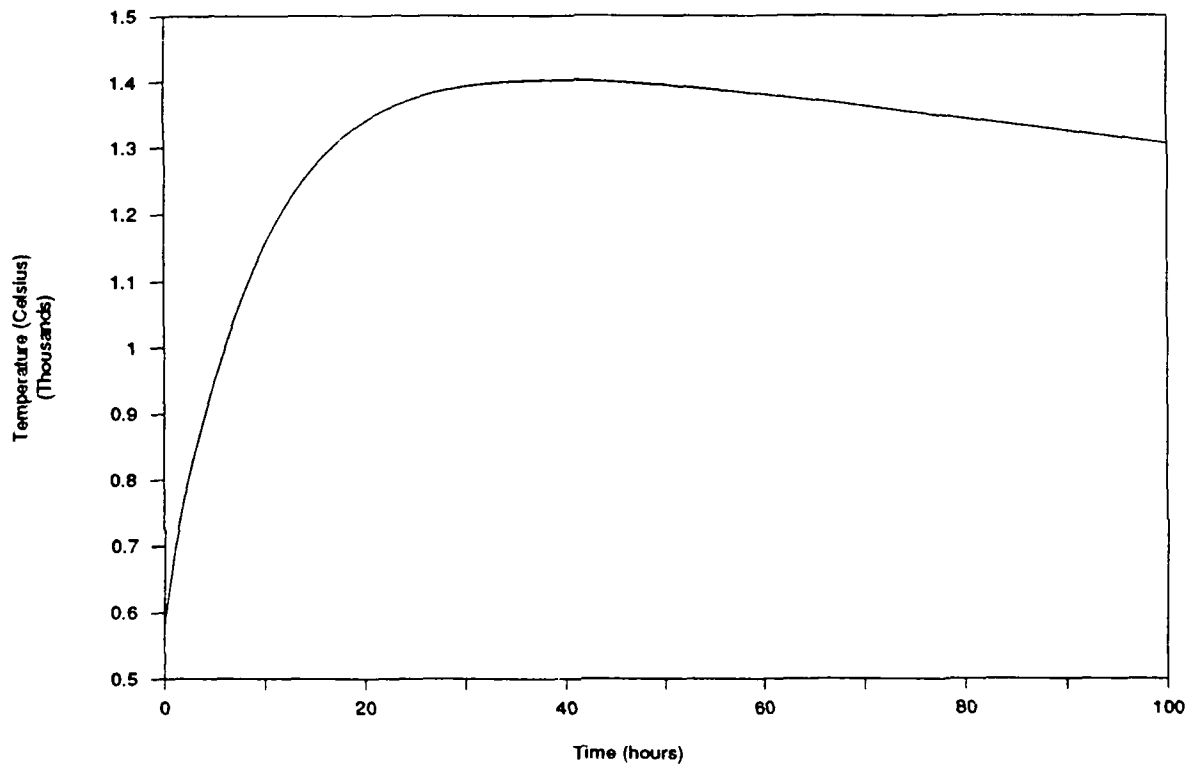

Figure 4-4. Core centerline temperature as a function of time after a depressurized loss of flow accident (baseline power level 39 MW/m).

Notice that even with the conservative model, centerline temperatures never get close to the 1600°C required for fuel damage. There is a safety margin of 200 degrees at the baseline power level.

Figure 4-5 shows the radial temperature distribution for various times after the casualty. The top trace corresponds to the maximum centerline temperature 39 hours after event initiation. Of note here is that even though the center is at 1400°C the pressure vessel remain well below any temperature where damage could occur. Note that this is not the point of maximum vessel temperature. That would be near the top of the pressure vessel as the heat in the core rises.

A simple sensitivity analysis was also performed to determine what power level the reactor could operate at without exceeding the 1600°C limit. This is show in Figure 4-6. The three cases correspond to linear power level of 39, 49, and 59 MW/m (100%, 115%, and 125% baseline power level). The initial temperature distribution is the same for all three cases\* and the power density was increased by the same percentage at each node. Each case was run until centerline temperature reached a maximum. The results were then plotted and compared to baseline.

As the power level increased, the reactor reaches maximum centerline temperature quicker and at a higher value (1560°C at 37.7 hours @ 49 MW/m, 1703°C at 36.2 hours @ 59 MW/m). The results indicate that it would be safe to operate the reactor at 49 MW/m. However, since operating at 49 MW/m does not allow a reduction in reactor size because of criticality, the 200 degree safety margin afforded by operating at the lower power level will be used as a hedge against uncertainty.

---

\* It was assumed that the temperature distribution would not be significantly different at different power levels since the reactor operates at a constant exit temperature with the mass flow rate setting power level.

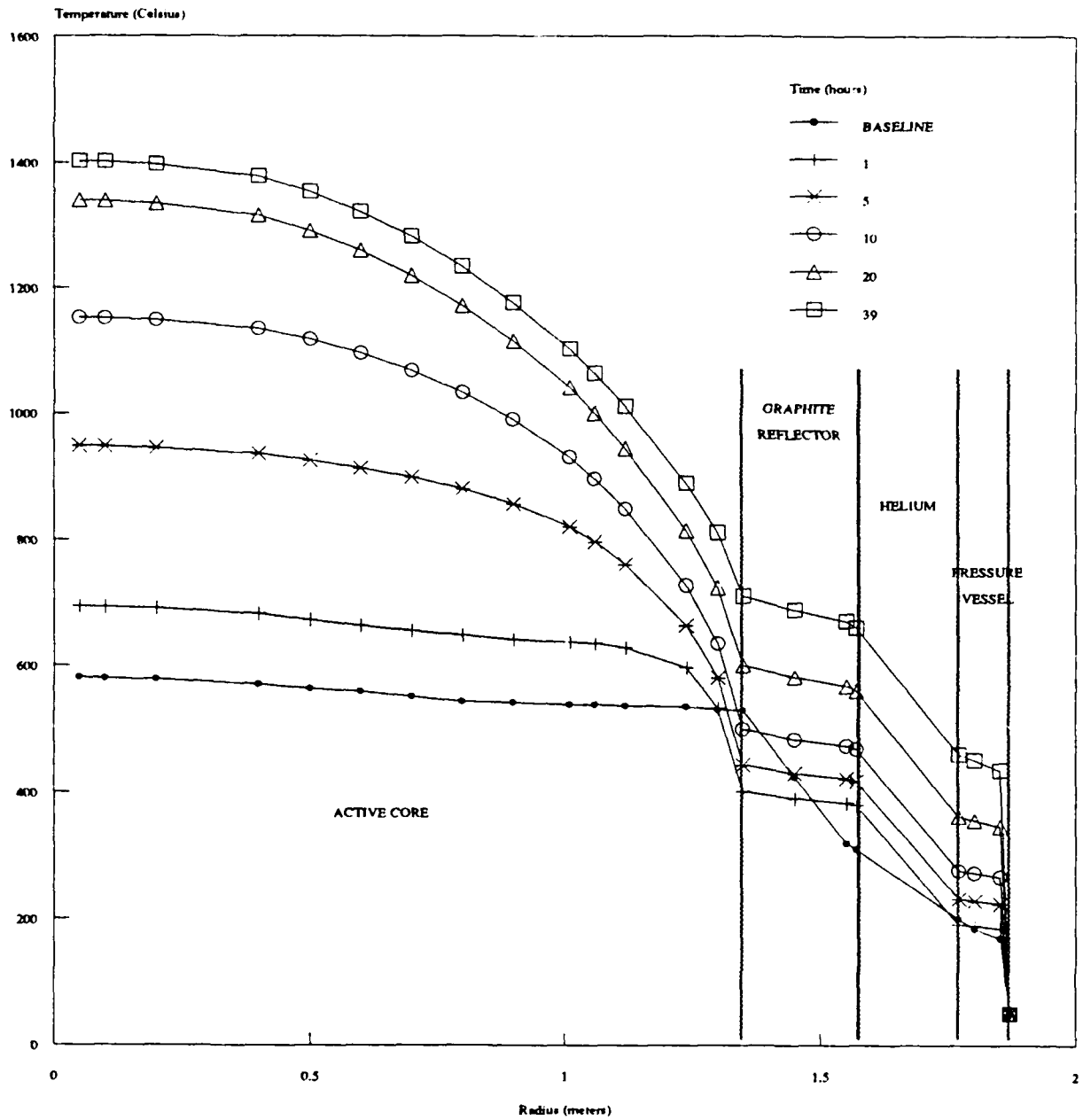

Figure 4-5. Radial temperature distribution history following a depressurized loss of flow accident. Temperature distribution peaks at 39 hours after event.

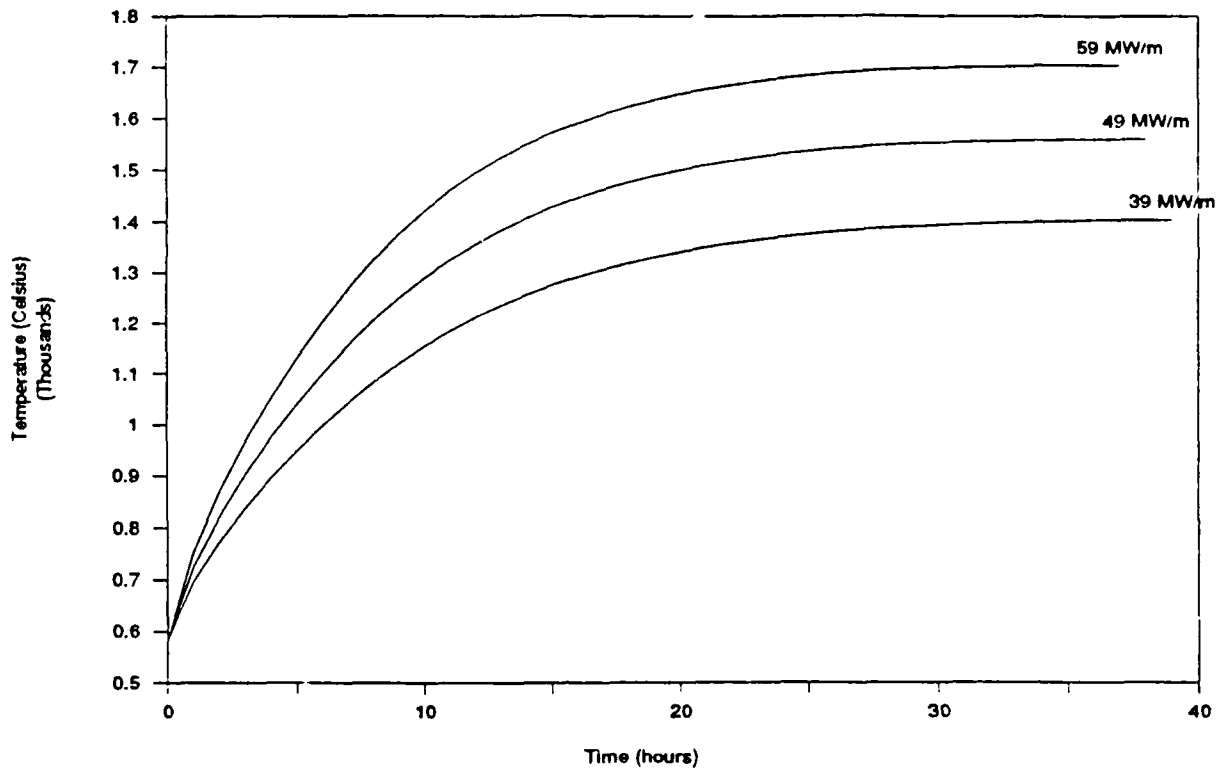

Figure 4-6. Effect of increasing linear power level on the core centerline temperature as a function of time after a depressurized loss of flow accident. The traces end at the time of peak temperature. The power level indicated is the average power produced by one meter of core length.

#### 4.4.2 Shock Loading.

The shock resistance of graphite moderated cores is an open question. Nuclear graphite when new has good strength and shock resistance (see sect. 4.2.2.) Whether or not these properties persist as they age in a neutron flux remains to be seen.

Of the three core types mentioned above the pebble bed is the most shock resistant. Assuming a shock load sufficient to break core graphite but not other core structures (control rods, piping, supports, etc.) the pebble bed's properties will not change much. As mentioned

above, damage to the pebbles does not cause loss of fuel containment. The broken pebbles will simply act like smaller pebbles. The above does not apply, of course to the graphite reflector, which could be significantly damaged by shock. For that reason, in the marine variant, the amount of graphite reflector is kept to a minimum, serving more as a thermal buffer for the core barrel than a reflector. Instead, the shielding water tank also serves as a reflector. The axial reflectors are unfueled pebbles so they are also immune to shock. With this configuration even if the radial graphite reflector is damaged the pieces should not move much and will tend to act as another unfueled pebble.

In a prismatic core the fuel is cooled by helium flowing through channels molded into the prismatic elements. Shock damage to this type of configuration could change the flow characteristics tremendously. Again, containment is not lost, but fragments could block flow passages in other elements causing local hot spots and possible fuel failure.

The conclusion is that the marine variant MGR-GT core should be very shock tolerant.

#### 4.4.3 Water Ingress.

Water ingress is a serious casualty in a graphite moderated reactor for several reasons. The first of which is that the superheated water vapor could react with the hot graphite causing degradation of the reactor structure and potential release of entrained fission products. The second and more serious problem is the large insertion of reactivity caused by the water. Izenon comments in his paper that the reactivity effects of water ingress were mostly a function of the heavy metal content of the fuel. By limiting the heavy metal content of the fuel to about ten grams per pebble and about eight percent enrichment, water ingress of any amount did not cause a reactivity increase greater than the delayed neutron fraction. [3] This is shown in Figure 4-7 as the increase in reactivity ( $\Delta k_{eff}$ ) as a function of the amount of water entering the core. Reactivity insertion was calculated for both the base core and a core con-

taining a small (0.1% wt) Gadolinium poison.

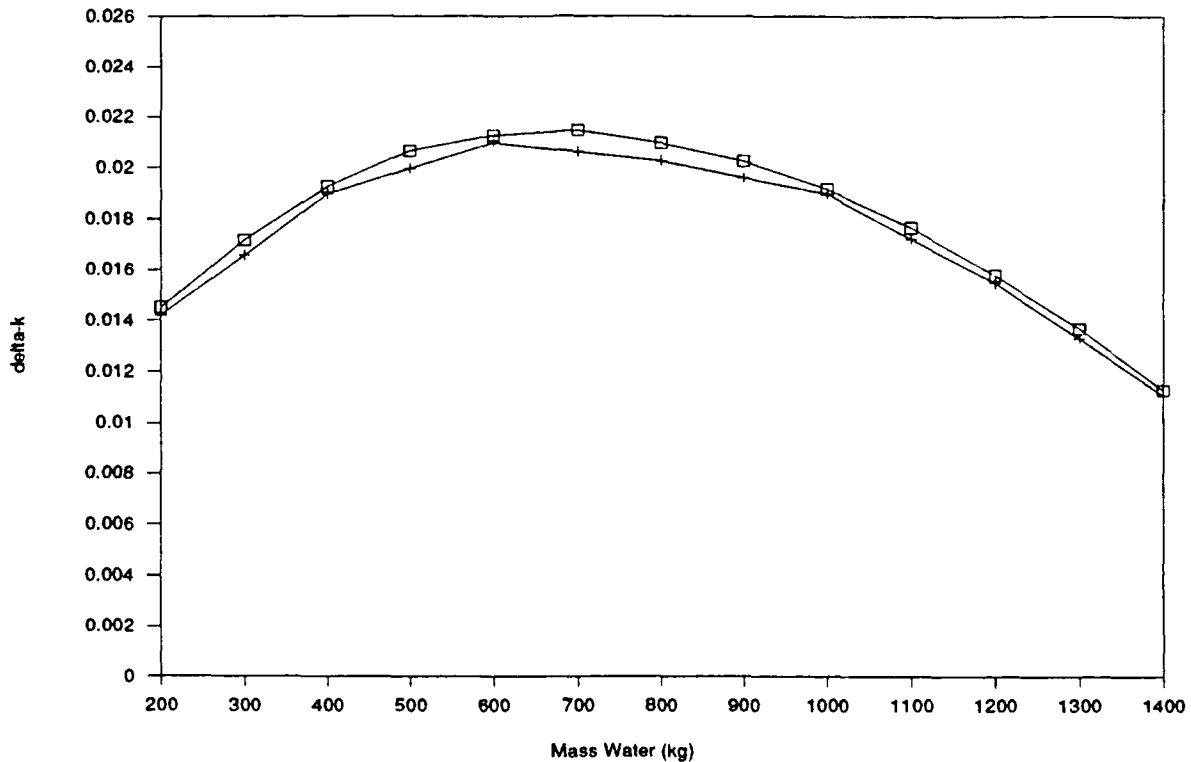

Figure 4-7. Reactivity effect of water ingress on the base and poisoned cores of the MGR-GT. The upper trace is the base core and the lower trace is the poisoned core. Enrichment = 7.5% wt  $U^{235}$ . The poisoned core has 0.1% wt Gadolinium. [3]

Although Gadolinium lowers the reactivity insertion the effect is slight and any advantage gained in the water ingress is offset by an increase in reactor power peaking. [3]

The Westinghouse Astronuclear Laboratory (WANL) conducted a feasibility study in 1979 of a large highly enriched gas-turbine reactor for a low specific weight power plant. They concluded that in that particular core the reactivity insertion due to core flooding was sufficient to cause the core to go super prompt critical. This is a serious consequence for a

reactor that is surrounded by water, and it tends to support Izenson's results that high enrichment increases susceptibility to damage from water ingress. The WANL reactor design operated in the epithermal region so their solution was to use a spectral shift type poison such as Gadolinium to reduce the reactivity. [4] Another possibility is to go to a fast core and again use thermal poisons to shut down the reaction when water enters. Much future work needs to be done in this area.

From the above, the marine core will be limited to the same 7.5% enrichment of the MGR-GT.

#### 4.4.4 Primary Coolant Retention.

An accident which causes the sudden depressurization of the primary system is potentially serious due to spreading of contamination, and the resulting pressurization of the reactor compartment/engine room. This is most significant for submarines because venting to the atmosphere is not an option. Assuming a catastrophic breach in the pressure boundary, turbine deblading or pipe rupture for example, with the entire helium inventory, including the inventory control vessels, venting into the compartment. The helium would expand into about 3 to 4 times their initial volume. With the primary system at 80 atmospheres, the compartment will equalize at between 16 to 20 atmospheres (530 to 660 feet of water). Modern submarine pressure hulls should easily withstand this pressure\*. Thermal shock to the pressure boundary should not be a great problem since in general the reactor compartment is surrounded by fluid which will keep structural temperatures down.

---

\* Although submarine pressure hulls are built to withstand external pressure, ring-stiffened cylinders are stronger with internal pressure than external pressure since buckling is not a problem with a cylinder in tension.

## 4.5 Core Size.

Core size is a complicated function of several factors; these are, criticality, thermal hydraulics, core life, control margin, and safety. The interaction of these factors will set or limit reactor characteristics. Given a pebble bed graphite moderated core with TRISO fuel particles, this section details how the reactor was sized and the assumptions used.

### 4.5.1 Criticality.

Reactor criticality calculations were performed using the Nodal Graphite Code (NGC) developed by Ediz Tanker. NGC is a two-dimensional nodal code for solving group diffusion equations. [15] The code uses a quadratic nodal scheme which permits mesh spacings twice as large as those required for finite difference codes. The program is written in FORTRAN and runs on desk-top personal computers. NGC requires the user to divide the core into a convenient mesh and provide the group cross sections for each node. Once the above is done the program will calculate  $k_{eff}$ .

The cross sections used to estimate  $k_{eff}$  for this design were the group cross sections used in the MHTGR by GA Technologies. The MHTGR is a five region annular, cylindrical core, graphite reflected on all sides, with an inner reflector. The cross sections were averaged over the MHTGR spectrum to produce the group constants. Although the spectrum for the MHTGR is not the same as the Marine MGR-GT it provides a starting point and it will give general limits for core and reflector size.

For my NGC calculations I used two-group cross sections and two material regions, active core, and graphite reflector. For the core region I used the MHTGR core cross sections. For the radial and axial reflector I used the cross sections for MHTGR region five. The following summarizes the results using this configuration.

**Bare core.** Bare core calculations were performed analytically and with NGC to get a starting point and to confirm NGC results. Core radius had to be at least 1 meter in order to achieve criticality ( $k_{\text{eff}} = 1$ ). Criticality was not very sensitive to core length and as long as the length was greater than about 2 meters the core could be effectively treated as an infinite cylinder.

**Reflected core.** Once bare core calculations were completed reflectors of various sizes were added to try to bring  $k_{\text{eff}}$  up to 1.25. A  $k_{\text{eff}}$  of 1.25 was used as a rough margin to give the core some extra reactivity for Xenon override, and to allow control margin and burn-up. Table 4-4 lists the results.

Table 4-4. Initial Core Size Estimates.

Active Core Radius	1.25 m
Active Core Length	3.00 m
Radial Reflector Thickness	50 cm
Axial Reflector Thickness	75 cm
Approximate enrichment	7%
$k_{\text{eff}}$	1.22

The above results were more reassuring than useful. What they showed is that the critical dimension is radius. Length had very little effect as long as it was greater than the core diameter. Also the addition of a reflector did not decrease total reactor radius. The smallest total radius (core & reflector) was the bare core. There was no combination of reflector and core that I could find which resulted in a smaller total radius than the bare core. The effect of the reflector was to either maintain the same  $k_{\text{eff}}$  with a smaller fueled region, or increase  $k_{\text{eff}}$  while keeping the diameter of the fueled region constant. They were also

reassuring in that even though the cross sections used were for an annular prismatic core, the dimensions were similar to the dimensions of the MGR-GT. Since length only seemed to effect overall power level and not  $k_{eff}$ , the above results led to the decision to use the MGR core dimensions as the basis of the marine design.

#### 4.5.2 Core length.

Reactor length was set primarily by the core power level. From Chapter 3, the required reactor power level to produce 40,000 SHP is about 80 MW(th). From 4.4 the core can operate safely at 39 MW/m of core length at the chosen diameter. Simple arithmetic results in an active core length of about 2 meters. However, since this is less than the core diameter (2.7 meters) setting the reactor length at 2 meters would result in excessive neutron leakage and a lower  $k_{eff}$ . For this reason I set the reactor length at 3 meters. The increased length will allow the reactor to operate at a lower power level than it is capable of.

The benefits of the lower power level are:

1. A longer core life since there is less burn-up.
2. Increased safety margin.
3. More control drum worth due to the increased length and better aspect ratio. A long thin core is better for periphery control than a short fat one because the rods are longer and the radial leakage is higher in the thin cores. A short fat core would be better if internal control rods were used.
4. Heat transfer is enhanced since the heated length is greater.

The major drawbacks are:

1. The larger core is harder to arrange within the ship envelope.
2. More shielding is required to cover the increased length

3. Core pressure drop is directly proportional to core length, so a long thin core has a higher relative pressure drop than a short fat one at the same pressure and mass flow rate.

Another alternative is to increase system power level to use the extra length. At 40 MW/m a 3 meter core is capable of being safely operated at 120 MW. This would correspond to a system power level of 60,000 SHP. Since the power conversion equipment (turbines, generators, heat exchangers, etc.) would have to be enlarged to match this is not a viable option for a small ship design. It may be a good choice for the carrier design since it would drop the total number of plants needed from eight to five or six.

#### 4.6 Radiation Shielding.

Because of the low activation cross section of helium, it is not expected that the primary system outside of the reactor itself will require shielding from manned areas. Any fission product plate-out or radioactive dust which may accumulate on piping or in components will cause radiological precautions to be needed during maintenance but the component pressure vessel and insulation along with the reactor compartment bulkheads should be sufficient for the primary system.

Primary reactor shielding, intended mainly to stop neutrons, will come from the shielding water tank which surrounds the reactor. The shielding water tank also acts as a heat sink as explained above. Additional shielding is provided by fuel oil\* or other tanks separating the reactor compartment from manned spaces. Where intervening tanks are not possible, such as the shielded tunnel in a submarine or above the reactor compartment in a surface vessel the shielding will be extensive.

---

\* All nuclear powered ships have emergency power generators (diesel or gas turbine) for use when reactor power is unavailable.

Because of the large size of the reactor core the shielding will be a major component of the plant weight. To estimate the shield weight reference 17 will be used. In reference 17 several shield designs were presented for a gas-cooled, intermediate spectrum reactor, at a power level of 100 MW thermal. A lead-water shield is used to reduce dose rate to 0.5 mR/hour at the edge of the shield. Water is used as the thermal neutron shield and lead is used for the gamma shield. The shield consists of 25 cm of lead at the pressure vessel surrounded by 180 cm of water. Using the core dimensions listed below in Table 4-5 the shield dimensions can be estimated. The thermal neutron shield will be a 1.8 meter thick water tank 6.7 meters high. The tank inner radius is 1.85 meters and the outer radius is 3.65 meters. Surrounding the core tank is a 25 cm thick lead  $\gamma$ -shield. The lead is positioned several centimeters away from the inner wall of the shielding tank to allow fluid circulation. This results in approximately 230 metric tons of water and 260 metric tons of lead, a total radial shield weight of about 490 metric tons. This figure can be taken as a practical upper limit of shield weight since in a actual shield design the reactor would not be shielded equally all around. Heavy shielding would go around manned spaces, such as the overhead in a surface ship and the shielded passageway in a submarine, while other areas would get little or no shielding (the bottom for example).

#### 4.7 Reactor Design Summary

This section summarizes the design of the reactor heat source. Figure 4-8 shows a cross section through the marine MGR-GT reactor core. Figure 4-9 shows two side profiles. The left hand side is a section through a control drum and the right hand side is through the co-axial helium ducts. Co-axial ducts are used to reduce insulation requirements on ducting and to lower the temperature of pressure boundaries. Notice that with this flow arrangement the reactor vessel is continuously swept with 'cool' compressor discharge helium.

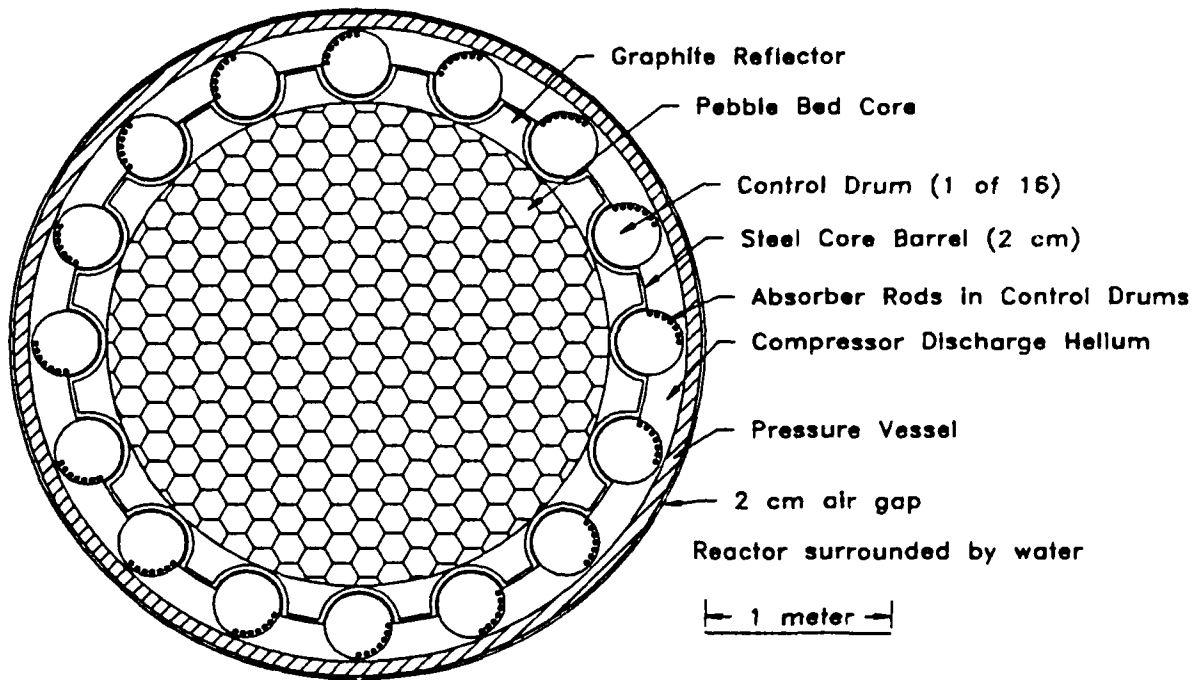

Figure 4-8. Section through Marine MGR-GT core showing pressure vessels and control drums. The reactor is surrounded by the shielding water tank and is separated from the tank by a 2 cm air space. The hatching in the central core denotes pebble, not hexagonal, fuel elements.

Table 4-5 summarizes the marine reactor characteristics and Table 4-6. gives the weight summary. Weights were estimated using the geometry shown in Figures 4-8 and 4-9 along with known density for the various materials. This weight estimate does not include foundations.

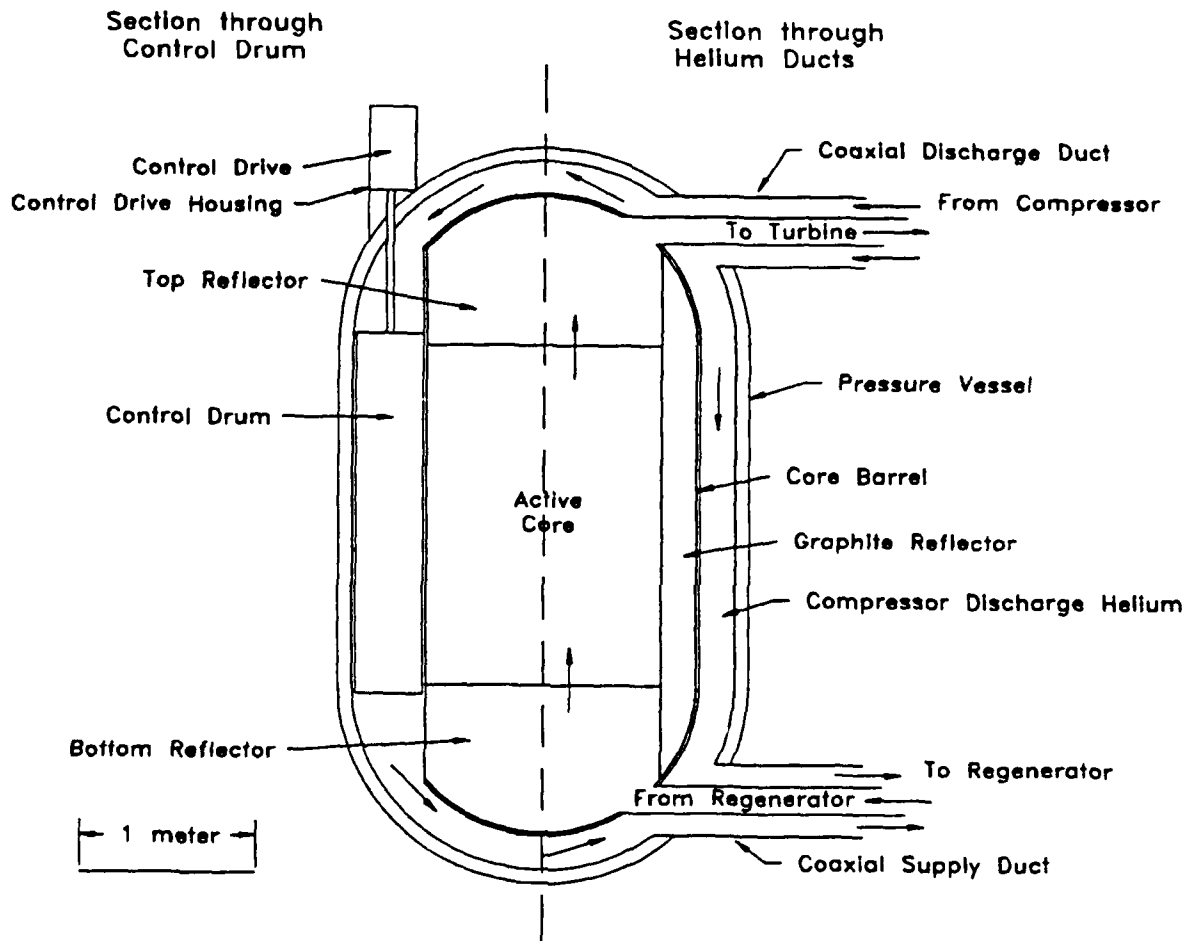

Figure 4-9. Side profile of the Marine MGR-GT showing gas flow path. Pressure vessel and Control drum are cooled by compressor discharge flow.

Table 4-5. Marine MGR-GT Reactor Summary.	
Pressure Vessel	
Height	6.7m
Outer Diameter	3.7 m
Thickness	8 cm
Active Core	
Type	Pebble Bed
Height	3 m
Diameter	2.7 m
Fuel	~ 92645 Fuel Pebbles 6 cm diameter loaded with 7 g Uranium
Enrichment	~ 7.5% U <sup>235</sup>
Control	16 Reflector/Absorber Drums.

Table 4-6. Reactor Weight Summary.	
Component	Weight (metric tons)
Core pebbles	17.3
Graphite reflector	4.5
Core Barrel	10.5
Control drums	9.0
Pressure Vessel	44.7
Upper Reflector Pebbles	8.8
Lower Reflector Pebbles	8.8
Total	103.6

## Chapter 5 Mechanical Design.

### 5.1 Heat Exchanger Design.

System heat exchangers form a crucial part of the overall design. Because of the relatively poor heat transfer characteristics of gasses, compared to water, heat exchangers of high effectiveness, low pressure drop, and small size are difficult to create. Small size is obviously necessary to reduce both weight and volume. High effectiveness and low pressure drop are critical factors in cycle thermal efficiency. This was shown in Chapter 3, Figure 3-3. In order for this design to be successful reasonable sized heat exchangers with good effectiveness and pressure drops need to be found.

This section details the design of the main system heat exchangers, the regenerators and the precoolers.

#### 5.1.1 Regenerator.

The regenerator is the only gas-gas heat exchanger in the entire system. Shell and tube designs have traditionally been used in commercial applications because they are rugged and relatively easy to inspect and repair. Their main disadvantage is size. Because of the need for compactness, traditional shell and tube heat exchangers will not work.

In recent years the technology necessary to design and build compact plate-fin heat exchangers for use in high-temperature, high pressure difference applications has greatly improved. Their greatest use has been in the large gas-turbine powered, gas pipeline compressors. These regenerators have accumulated thousands of hours of operating experience with not one failure. [8] Using the same technology on the marine MGR-GT should be a relatively simple task, especially since the marine recuperator will be operating in a clean helium environment. The clean environment means that the fouling caused by combustion gasses cannot occur, thus the heat exchanger passages can be made as small as necessary to

meet design objectives.

The regenerators were designed using the effectiveness-NTU method as detailed in Kays and London's *Compact Heat Exchangers*. [11] The mechanics of this method were incorporated into a heat exchanger analysis program COMPHX.BAS. COMPHX.BAS and the effectiveness-NTU method are detailed fully in Appendix B.

The first step in using the program was to define general cycle parameters (Chapter 3) such as required effectiveness, maximum pressure drop, and entrance and exit temperature and pressure. Then several heat exchanger surfaces were selected from the surface geometries listed in Reference 11. These surfaces are listed for reference in Appendix C.

The main selection criteria was the compactness ratio,  $\alpha$ , which is defined as the ratio of surface area to heat exchanger core volume, the higher the  $\alpha$ , the more compact the heat exchanger. For this study, every heat exchanger surface with  $\alpha$  greater than  $800 \text{ ft}^2/\text{ft}^3$  ( $2600 \text{ m}^2/\text{m}^3$ ) was analyzed using COMPHX and the Brayton cycle analysis spreadsheet from Chapter 3. Of the five surfaces used the best performance came from surfaces 46.45T and 1/9-24.12 in Kays & London\*. The characteristics of these two surfaces are shown in Figures D-1 and D-2. Surface 46.45T has plain fins which extend the full length of the heat exchanger, while in surface 1/9-24.12 the fins are short offset strips which serves to interrupt the flow.

For the initial analysis at least, the same surface was used on both hot and cold sides of the heat exchanger. After the results of the initial analysis were done it was noticed that most of the total pressure drop through the heat exchange was on the hot side. The fluid velocity on the hot side is higher than the cold side because of the lower pressure (therefore density.)

---

\*These surfaces are numbered 1-18 and 3-17 in Appendix C.

To try to mitigate the hot side pressure loss, a surface with larger flow passages was used on the hot side (1/8-20.06) with surface 1/9-24.12 on the cold side. While this configuration successfully lowered the pressure loss, it resulted in a much larger volume and weight, rendering it unacceptable. Table 5-1 summarizes the results of the analysis for the three surfaces, 46.45T, 1/9-24.12, and the combination 1/9-24.12 & 1/8-20.06. Stainless steel was the material used with a separating plate thickness of .1 cm.

Table 5-1. Regenerator performance analysis and sizing results.

	<u>1/9-24.12</u>	<u>46.45T</u>	<u>Combination</u>
<u>Size Summary</u>			
Core length (m)	1.5	1.5	1.75
Frontal area (m <sup>2</sup> )	2.5	2.5	3.5
Height* (m)	2.4	2.4	2.6
Core volume (m <sup>3</sup> )	3.75	3.75	6.13
Weight (Mtons)	10.4	14.2	17.2
<u>Performance Summary</u>			
Effectiveness (%)	94.9	93.2	94.9
NTU	18.6	13.7	18.9
Pressure drop (%)			
Hot-side	1.81	1.06	.35
Cold-side	.71	.42	.93
Total	2.52	1.48	1.28
<u>System Performance</u>			
Massflow (kg/s)	27.4	26.6	26.47
Thermal efficiency	.488	.487	.497

The performance of the three regenerators is very close, especially between 46.45T and 1/9-24.12. The plain fin surface is less effective and weighs more, but has a lower pressure drop than the strip fin surface. As a result they have an almost identical effect on system

\* Height includes cross-flow headers.

performance. The best system thermal efficiency is achieved by the combination heat exchanger. However to achieve a 95% effectiveness it had to be 7 tons heavier and twice the volume of 1/9-24.12. In a tight design, the marginal efficiency increase does not justify the weight and size. Though either of the other two would be acceptable, the lower weight of the strip-fin exchanger gives it the advantage.

### 5.1.2 Precooler.

Unlike the regenerator the precooler has helium gas on only one side. With water on the other side, corrosion and fouling must be taken into account. For this reason a simple cross-flow shell and tube heat exchanger will be used. The helium will be on the shell side with water flowing through the tubes. Shell and tube heat exchangers work well with a high pressure difference between the two fluids and can easily be made robust and shock resistant. With this arrangement the tubes can be easily finned to augment the heat exchange surfaces (although it will be seen later that this does not produce the most compact design) and the water plenum and tubes can be accessed relatively easily for maintenance.

The use of tubes also facilitates locating and fixing leaks. A plate-fin exchanger would be more compact but a leak between the two sides would be difficult to locate and even more difficult to repair. In the regenerator a leak will reduce system performance by a small amount but it will not damage the system. A leak in the precooler, however, will either result in potentially contaminated helium escaping to the environment or worse, water ingress into the primary system. A leaky tube is easy to locate and repair (plug or replace.)

Once the choice of heat exchanger type is sizing is done using the same effectiveness-NTU method employed in sizing the regenerators. The difference between the two being two different fluids and cross-flow instead of counter-flow. The major concerns in the design

are: 1) minimum size, 2) minimal pressure drop, 3) reasonable water mass flow. For the purposes of this analysis the parameters listed in Table 5-2 considered as constants in the problem.

Table 5-2. Input parameters for use in the Precooler design.

<u>Parameter</u>	<u>Value</u>
<u>Helium Conditions</u>	
Massflow	27.4 kg/s
Temperature: Inlet	167 °C
Outlet	30 °C
Inlet Pressure	4.01 MPa
Pressure Drop	.25 %
<u>Water Conditions</u>	
Inlet Temperature	20 °C
Massflow	250 kg/s (~4000 gpm)
<u>Heat exchanger Material</u>	304 Stainless steel

With the input conditions defined the next step is to select several candidate surface geometries from Reference 11. Only heat exchangers with circular tubes were considered for reasons given above. Four configurations were selected based again on the largest values of  $\alpha$ . Two of them were bare circular tubes with different diameters and tube pitch, one contained circular tubes with circular fins and the last used circular tube with continuous fins (like a car radiator). Figures D-3 through D-6 show the surface geometry and performance characteristics. The characteristics are included as data statements in the PRECOOL.BAS source code.

The program PRECOOL.BAS was then run to size the precooler using the four surfaces. The program is explained in detail in Appendix B, however what it basically does is

pick an initial guess at the dimensions of the heat exchanger, then analyze it using the helium and water parameters from Table 5-2. If the results do not match requirements the dimensions are adjusted until they do. Table 5-3 lists the results.

Table 5-3. Precooler performance and sizing results.

	<u>CF-8.72</u>	<u>S 1.50-1.00</u>	<u>S 1.50-1.25</u>	<u>8.0 3/8T</u>
Tube length (m)	1.93	1.92	<b>1.20</b>	1.87
Width (m)	.82	.73	<b>1.19</b>	.72
Depth (m)	2.59	.99	<b>.756</b>	3.38
Frontal area (m <sup>2</sup> )	1.58	1.40	<b>1.43</b>	1.43
Volume (m <sup>3</sup> )	4.09	1.39	<b>1.08</b>	4.84
Number of tubes	4215	5289	<b>11901</b>	4603
Weight (kg)*	3564	534	<b>346</b>	3528
Effectiveness	.932	.932	<b>.932</b>	.932

Based on the results in Table 5-3, a precooler using surface S 1.50-1.25 is clearly the best choice. It is somewhat surprising that the bare tubes did better than the finned surfaces. The explanation for this is that the finned surfaces rely on the fins for most of the heat transfer. The tubes are relatively widely spaced in comparison to the bare tube surfaces. The relatively poor thermal conductivity of stainless steel reduces the effectiveness of the fins. Therefore the primary heat exchange surface is the tubes themselves. The bare tube surfaces use smaller tubes at a fine pitch so they have more effective heat exchange area per unit volume than the finned surfaces. If a more conductive material were used (such as aluminum) the situation would be different.

\* Weight is weight of tubes and fins. It does not include headers, support plates, or the outer envelope. The weight of the other items will be roughly proportional to volume.

## 5.2 Bearing Design.

One of the major problems in closed cycle systems is keeping the circulating fluid clean. Contaminants in the system are constantly circulating unlike a open cycle where they quickly leave the circuit. Keeping the system clean is especially important in this reactor design. If lubricants from the bearings of the rotating machinery were to enter the circuit the results could range from contamination and fouling of flow passages in heat exchangers and the core to chemical reaction with core graphite and reactivity excursions. Much of the poor availability of the Fort St. Vrain nuclear power plant can be traced to water ingress from the water-lubricated bearings on its gas circulators. [8][18]

### 5.2.1 Magnetic Bearings Properties

Although fluid lubricated bearings are generally very reliable and the technology well established prevention of leakage requires complicated seals and extensive supporting equipment. Gas bearings have been used with great success in small high speed systems, however, the technology base for the large gas bearings that this reactor design requires does not exist. Because of the severe potential problems associated with mechanical bearing lubrication systems (either water or oil). The only bearing system considered for this design was active magnetic bearings.

Active magnetic bearings work by levitating the rotating equipment with a magnetic field instead of a fluid film. The technology is not new, and several companies (mostly French) currently market bearings and control systems large enough to handle the needs of the marine MGR-GT. Table 5-4. lists the major advantages of magnetic bearings in this application.

### Bearing Configuration.

Table 5-4. Advantages of Active Magnetic Bearings.[18]

- 
- Elimination of system contamination by lubricant ingress
  - Elimination of fire and explosion hazards
  - Elimination of costly lubrication equipment and complex sealing and gas buffering systems
  - Lower power consumption and overall system volume than comparable fluid lubricated bearings
  - Reduced bearing frictional parasitic losses
  - Unlimited bearing service life (no contact or wear surfaces)
  - High rotational speed capability
  - Vibration free operation (ability to pass critical speeds)
  - Alignment and balancing simplification
  - Continuous monitoring of rotor status
  - Responsive to rapid system transients
  - Reduced maintenance
  - Simplicity of operation and control (computer system)
  - Potential for very high reliability.
- 

Magnetic bearings consist of two types: radial bearings, which maintain the rotor position in the center of the bearing; and axial bearings, which maintain the longitudinal position of the rotor. Radial bearings resemble electric motors in construction. (Fig. 5-1) The outer stator is electrically divided into four electromagnetic quadrants. Each quadrant contains north and south poles which attract the rotor when current is supplied to its poles. In an axial

bearing, a flat solid ferromagnetic disk, fitted radially to the shaft, is used for the rotor. Electromagnets are positioned on both sides of the disk. By varying the current flowing to each magnet the disk is attracted to either side thus creating a double acting thrust bearing. (Fig. 5-2)[20]

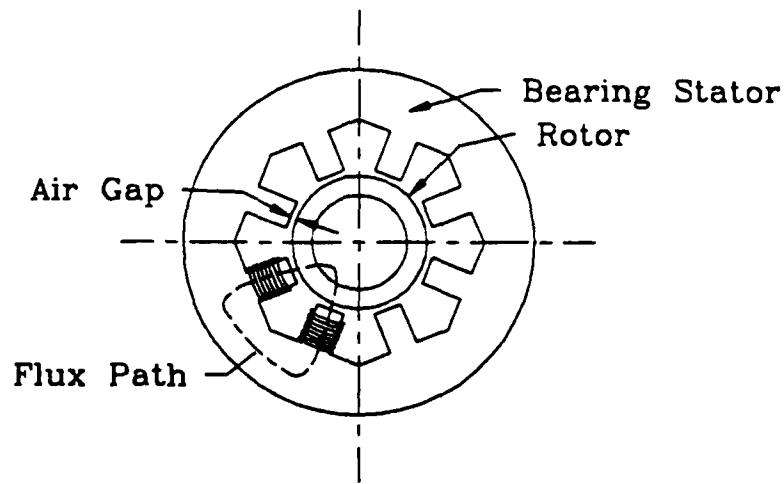

Figure 5-1. Radial Magnetic Bearing. [20]

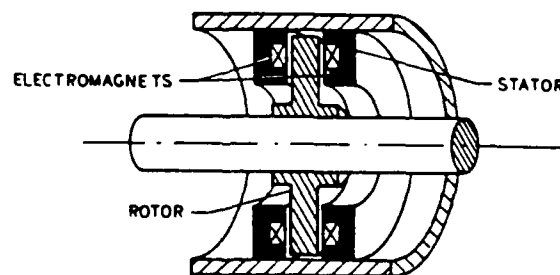

Figure 5-2. Axial Magnetic Bearing. [20]

Since the magnetic bearing is a non-contact bearing, auxiliary mechanical bearings have to be included as a backup in case of power failure, bearing overload, or other bearing failure. They would only be in use during shutdown, or other temporary or emergency situations. The bearings have to be dry-lubricated to prevent the very same lubricant ingress problems that the magnetic bearings were being used for in the first place. Figure 5-3 shows how the auxiliary bearings would be employed in a magnetic bearing machine.

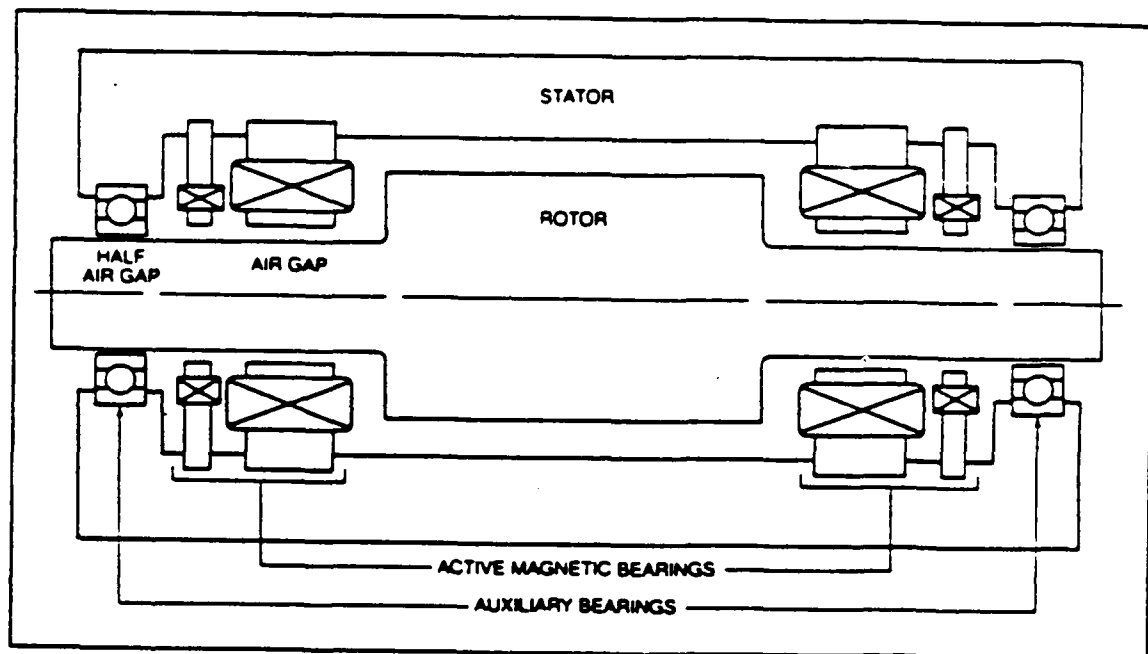

Figure 5-3. Basic arrangement of auxiliary bearings in machine with magnetic bearings. [8]

### Bearing Control.

Since attractive magnetic bearings are unstable an active control system is used to keep the bearing in position (Fig 5-4.) Integral to the bearing position sensors are used to continuously determine the exact location of the rotor. This position information is then fed back into a closed-loop control system with a proportional, integral, derivative controller. The

control system generates an error signal which goes to power amplifiers. The resulting current change corrects any error in the rotor position. The damping and stiffness of the system is a function of parameters programmed into the controller. Unlike mechanical bearings, these parameters can be changed as conditions require, making the bearing very responsive, especially at shaft critical speeds.

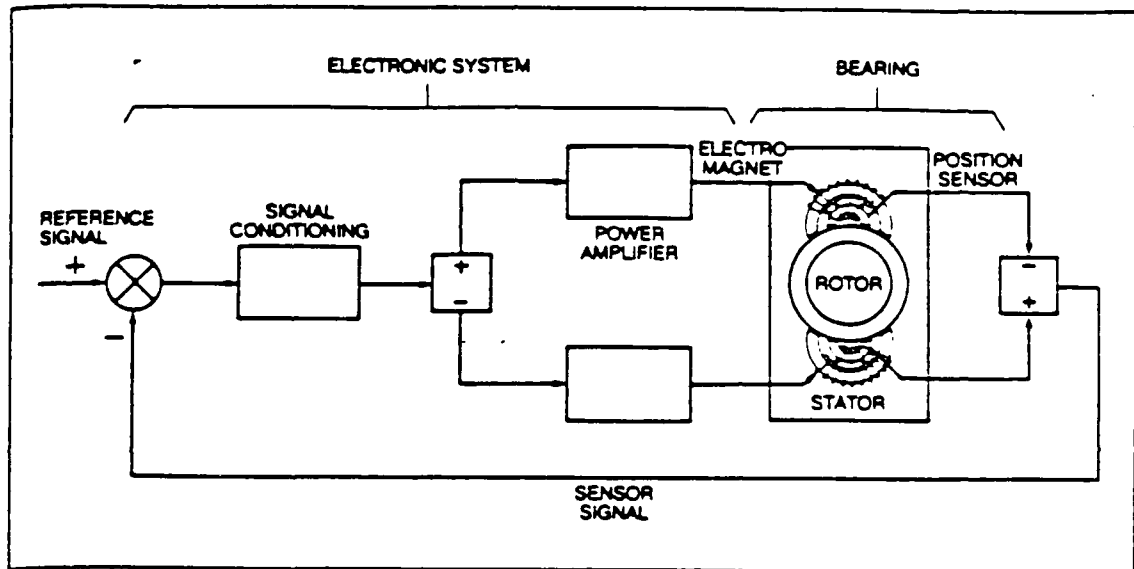

Figure 5-4. Diagram of an active magnetic bearing control system. [8]

### Vibration Reduction and Automatic Balancing.

Another attractive feature for magnetic bearings is their ability to automatically balance a rotor through inertial axis control, and active vibration reduction. Figure 5-5 shows a representation of how automatic balancing works. The rotor effectively is allowed to rotate around its inertial axis instead of its geometric axis. As long as the imbalance is not too great, the result is very quiet and smooth operation with no forces transmitted into the supports. Also by placing vibration sensors on the bearing the control system can create oppos-

ing forces to cancel the vibration. In tests on a auxiliary turbine for a forced draft blower vibration and sound level reduction of between 10 and 25 dB were achieved.[20] This is very attractive for a submarine application where noise reduction is very important.

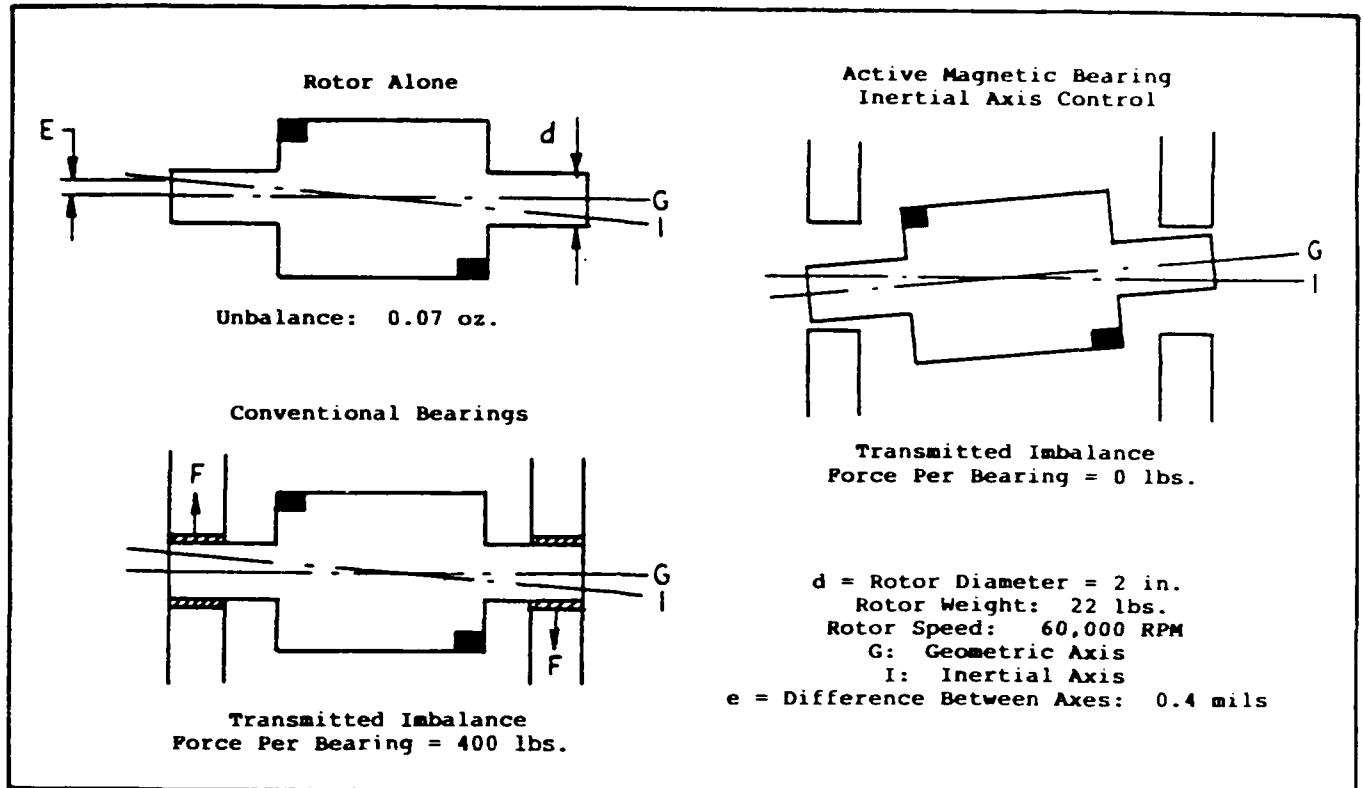

Figure 5-5. Automatic balancing: a diagrammatic representation of how inertial axis control works.[20]

### Reliability.

Although reliability data on installed magnetic bearing systems are still being accumulated, it being a new technology, the operating data as of 1985 on industrial applications, showed that in over 38,000 hours of operation there were 26 failures (12 on one machine). In all cases the power amplifier was at fault and in no case was there any damage other than the failed electronics. [8] Therefore the reliability of the system seems to be a function of the reliability of the electronics. This is fortunate, from a maintenance point of view, since it is

much easier to carry extra electronic modules and replace them at sea than to repair bearings. As experience is gained, the problems with the early systems should be corrected and magnetic bearings should become very reliable.

### 5.3 Turbomachine design.

The turbine and compressor design will follow the design method proposed by Staudt for the MGR-GT. The method used to design the turbines for the marine variant is to take the baseline machine from Reference 8 and apply some scaling relationships. For this purposes of this paper both turbines in the split shaft arrangement are assumed to operate at the same speed. This is not necessarily true but as will be seen later both shafts have to drive generators, and it is much more difficult to design an acceptable high speed generator than it is to design a high speed turbine.

#### 5.3.1 Baseline Turbomachine. [8]

The MGR-GT turbomachine combination is used as the baseline for the scaling relationships of the next section. Table 5-5 lists the characteristics.

Table 5-5. Characteristics of the MGR-GT turbomachinery.

	<u>Turbine</u>	<u>Compressor</u>
Stages	6	15
RPM	10000	10000
Tip Diameter (cm)	86.2	73.3
Bladed length (cm)	63.0	130
Poly. Eff. (Expected)	.931	.937
Poly. Eff. (minimum)	.91	.91

### 5.3.2 Scaling Relationships.

In Reference 8 Staudt derives a series of scaling relationships for turbomachines. The relationships allow one to study the effects of changing plant parameters (pressure, mass flow rate, etc.) on turbomachine size. Once a 'good' design is found, good estimates can be made of other machines with different system parameters. The basis of the equations that follow are that blade velocity triangles and blade stress remains constant.

The first set of scaling ratios relate the blade tip diameter ( $D_t$ ) and rpm ( $N$ ) to changes in system pressure, power level held constant:

$$D_t = D_t^* \sqrt{\frac{P^*}{P}} \quad 5-1.$$

$$N = N^* \sqrt{\frac{P}{P^*}} \quad 5-2.$$

The second set of scaling ratios relates the blade tip diameter and rpm to mass flow rate  $\dot{m}$  (power level) and number of stages ( $n$ ), pressure held constant:

$$D_t = D_t^* \sqrt{\frac{\dot{m}}{\dot{m}^*}} \quad 5-3.$$

$$N = N^* \sqrt{\frac{\dot{m}^*}{\dot{m}}} \quad 5-4.$$

$$D_t = D_t^* \left( \frac{N^*}{N} \right)^{\frac{1}{3}} = D_t^* \left( \frac{n}{n^*} \right)^{\frac{1}{4}} \quad 5-5.$$

As can be seen from the above that increasing the system pressure reduces machine size and increases the speed. At constant pressure, lowering the mass flow and thereby the power level produces the same effect, smaller size and faster.

The final scaling equation relates rpm, and number of stages (n) and mass flow between any two machines with the same inlet and exhaust temperatures and pressure ratios.

$$n^{.75} \cdot N \cdot \left( \frac{\dot{m}}{\rho} \right)^5 = \text{constant} \quad 5-6.$$

### 5.3.3 Turbomachine Design Results.

Using the above equations will produce turbomachines similar in performance to the baseline machine. This is in absence to any consideration of what is attached to the machine. Recalling from Chapter 3 the expected cycle conditions for the marine version, the pressure and temperature were the same as the MGR-GT but the mass flow was only 27.4 kg/s verses 150 kg/s in the MGR-GT. The results using two different scaling methods (same number of stages, and set RPM) are listed below.

Table 5-6. Results of using scaling relationships to size marine MGR-GT turbomachinery.

	<u>Turbine</u>		<u>Compressor</u>	
Stages	6	20	15	72
RPM	23307	7200	23307	7200
Tip Diameter (cm)	36.0	96.1	31.3	81

From the above it can be seen that both designs produced by scaling relationships were unacceptable. The first design is nice and compact, but at 23,000 rpm, designing an acceptable generator becomes very difficult. The second design produces a marginally acceptable turbine, but the compressor at 72 stages would be too long and unwieldy to be used.

The conclusion is that the design parameters that formed the basis of the MGR-GT design would not be acceptable in the smaller version. A solution would be to reduce system pressure, this is also unacceptable. A lower pressure would greatly increase the core pressure drop and heat exchanger size. Discussions with several mechanical engineers have led me to the conclusion that an acceptable turbine/generator package can be designed, but it would take a dedicated design that is beyond the scope of this work. For the purposes of the rest of the analysis I will assume the turbine-compressor package is the same size as the MGR-GT and rotating 7200 rpm. It is probably not a good assumption that the turbomachinery can be the same size at 7200 rpm as it was at 10,000. However, several suitable 7200 rpm generators were found in the literature, and none which had a higher rotational speed. This does not imply that a suitable generator does not exist, just that it was not found.

To estimate the size of the two turbines in the split shaft design it was assumed the two turbines were one turbine with the shaft split at the proper location. The high pressure (HP) turbine must power the compressor and the ships service generator. This is a total power requirement of 18.8 MW. The power turbine must power only the propulsion generator, for a total requirement of 16.0 MW. Using the above assumptions and the characteristics of the MGR-GT turbomachinery, the marine variant will have the following characteristics.

Table 5-7. Characteristics of the marine MGR-GT turbomachinery.

	<u>Turbine</u>		<u>Compressor</u>
	<u>Compressor</u>	<u>Power</u>	
Stages	4	3	15
RPM	7200	7200	7200
Pressure* (MPa)	8.1	5.1	8.2
Temperature (°C)	850	717	30
Tip Diameter (cm)	68.4	86.2	73.3
Bladed length (cm)	42.0	31.5	130
Poly. Eff. (minimum)	0.9	0.9	0.9

---

\* Pressure is at turbine inlet or compressor outlet.

## Chapter 6 Electrical Design.

This chapter details a possible electrical system design. A full electrical analysis of the system including optimization and component design was not performed. The intent of this chapter is to discuss technology and the broad requirements that the electrical system would have to meet. Possible equipment configurations will be discussed along with advantages and disadvantages found.

### 6.1 Design Considerations.

In designing the power system the following design consideration were adopted:

- Generators must rotate at the same rpm as the prime mover. (No reduction gears allowed)
- Ships service power must be 'clean', ie. none or few harmonics, constant voltage and frequency independent of ship maneuvering.
- Minimum size and weight.
- No rotating mechanical seals subject to full system helium pressure are allowed. (to reduce helium leakage)
- Components should require no more than 'medium-risk' in development. Thus superconducting motors and generators will not be considered.
- Both the propulsion bus and ship service bus will operate at the same frequency. This will allow propulsion generator to power ship service loads if necessary.

### 6.2 Integrated Electric Propulsion.

There are several methods to transfer power from the turbines to the ship. They include direct drive, direct drive through reduction gears, direct energy conversion, and integrated electric propulsion. Direct drive can be ruled out immediately because the slow speed of the

rotating machinery (~180 rpm) would require huge turbomachinery. Direct drive through reduction gears would allow both the turbines and propellers to operate at their most efficient RPM. This method was also rejected because of the weight of the reduction gear and support equipment plus the difficulty of producing effective high pressure helium mechanical seals\*. Direct energy conversion of the scale required has not been demonstrated, and in keeping with the philosophy to minimize risk, rejects this method. This leaves integrated electric drive. A proposed single line diagram for a single shaft AIEP system is shown in Figure 6-1.

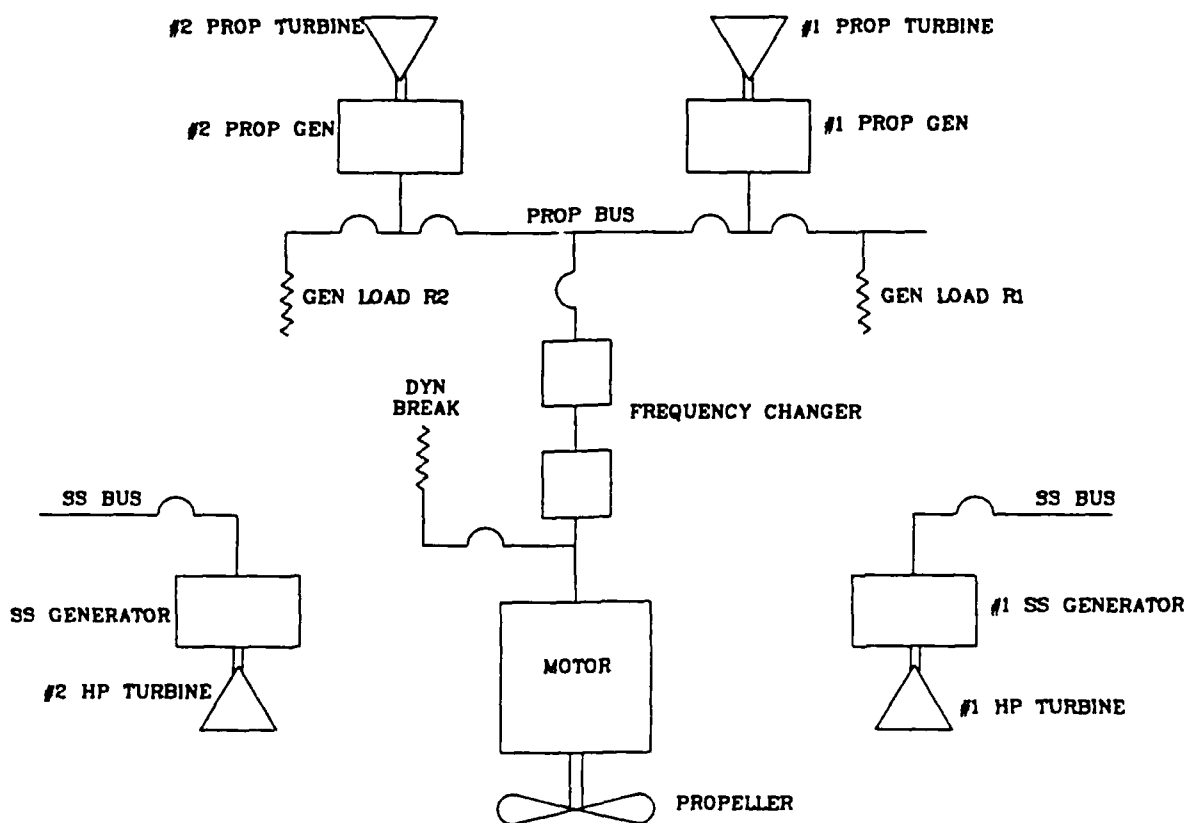

Figure 6-1. Integrated electric propulsion plant system, single line diagram. [adapted from Ref. 22]

\* In commercial power plants much of the helium leakage can be traced to the mechanical seals. Also seal lubrication could represent a potential contamination source for the primary system.

In an integrated electric drive ship, both ships service power and propulsion are derived from the same prime mover, in this case, the closed cycle turbines. This method of propulsion has been a source of great debate in recent years and it is not the intent of this paper to enter that debate. Advanced Integrated Electric Propulsion (AIEP) simply seems to be the best method for this particular choice of prime mover. Although electric propulsion has been used since before World War II, recent advances in power electronics and electric machine design has sparked renewed interest in this propulsion form. Some of the more significant advantages of AIEP are listed in Table 6-1.

Table 6-1. Electric propulsion system benefits. [22]

- 
- Arrangement flexibility for propulsion plant components
  - Variable reduction ratio between the prime mover and thruster
  - Increased control flexibility
  - Reversibility for unidirectional prime movers without gears or CRP propellers
  - Ease of electrical cross current capability
  - Distributed prime mover operating hours
  - Survivability Improvements
  - Facilitates ships service power from propulsion prime mover
  - Ease of automation
  - Ability to create a totally enclosed power system to reduce helium loss
- 

There are three main components that must be considered. The generators, which convert mechanical rotation to electric power; the power conversion equipment, solid state frequency converters to provide maneuvering and reversing capability to the third component,

the main propulsion motor. The motor that will be discussed is for either single shaft ships or twin shaft, twin reactor plant systems. It will not be appropriate for aircraft carriers or any other ship which requires more than one power module per shaft.

### 6.3 Generator.

The design of the system generators depends on several factors. They must be cooled, be compatible with the prime mover, and they must generate power that the system can use. The more efficient the cooling system the smaller the design. With the advent of reliable, efficient, solid state, frequency converters and power conditioners the generator can, for the most part, generate any convenient frequency and the power converters can do the rest. As discussed in section 5.3 the optimum turbine design requires a very high rpm, therefore the generators will be designed with the highest rpm possible.

The optimum use of equipment and space would be to have one generator coupled to a single turbine on each power loop. These two generators would power a single ships power bus, which would supply all ships loads, propulsion or ships service. In practice this has not been possible because of the harmonics and transients generated when the ship maneuvers. Modern electronic systems require cleaner power than is possible with this arrangement. Transients propagate too quickly for power conditioners to catch when the systems are linked electrically. With the arrangement shown in Figure 6-1 the only linkage between the two systems is thermodynamically through the reactor. This creates a natural buffering system which smooths out propulsion transients. The system therefore requires two different generator designs; a 2.5 MW ships service generator, and a 17 MW propulsion generator.

#### 6.3.1 Generator Cooling.

The cooling system for the generators has to effectively cool the generators without allowing either primary system helium to leak to the environment or outside agents, such as

water or oil, to leak in. This can be accomplished by one of two methods. The first is to cool the generator with high pressure helium. The second is to use water cooling in a pressurized casing.

**Helium Cooled.** Large commercial generators have cooled with hydrogen for since the 50's. The hydrogen cooling technology is well understood and could be applied directly to a helium cooled design. Helium has only slightly worse heat transfer characteristics than hydrogen and pumping power and windage losses would be similar. With the generator casing pressurized to near Brayton cycle system pressure, the rotating seal between the generator and compressor or turbine could be very simple and cooled by gas leakage. This was the method proposed for the MGR-GT [8]. Some disadvantages of this system are that it requires a separate helium system with cooler and circulator within the generator casing, and it results in a larger, heavier machine than the all water cooled machine.

**Water Cooling.** Recently (70's) techniques have been developed using water to remove the heat generated in both the stator and rotor. Water cooled machines have been used by central station utility generators for several years to increase power density. Figure 6-2 shows the improvement in power density realized by various cooling techniques versus the year of introduction. The increase in power density afforded by water cooling is quite dramatic. Another plus is that NAVSEA has determined that the risk of water cooled motors and generators is acceptable, thus clearing the way for their use aboard ship.[22]

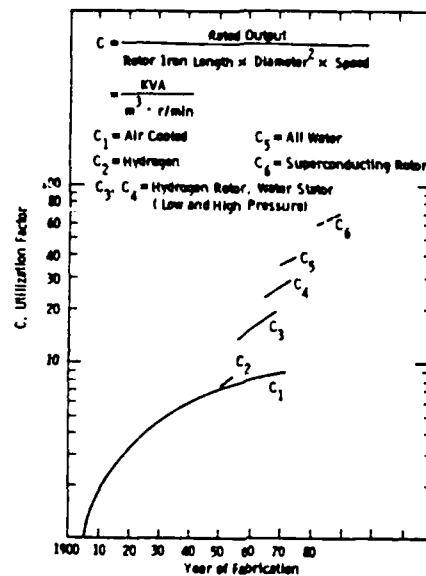

Figure 6-2. Historical generator power density trends.[22]

Water cooling in no way prevents the casing from being sealed and pressurized with helium to prevent leakage around the mechanical seal between the generator and the prime mover. The risk of water ingress into the primary system is minimal for two reasons. The first is the water will be at a lower pressure than the helium so any leakage will be helium leaking into the water not the other way around. The second is that the generator is separated from the primary system by a gas cooled seal around the shaft. The only way water could leak into the primary system is for both the generator cavity and the primary system to loose pressure and the generator cavity fill to the level of the seals. The helium cooled design also has the potential for water ingress since the helium cooler is integral to the generator casing.

Because of the significant weight and volume savings water cooled stators and rotors will be employed in this design.

### 6.3.2 Propulsion Generator.

Each propulsion generator has to provide 16 MW. It would have to rotate at 23,000 rpm to optimize the turbine. To design an acceptable generator at such a high speed is probably possible but no previous design could be found to support this. The 'best' rpm would have to be a trade off between the turbines and the generators. Several designs with similar power levels at speeds up to 7200 rpm were found and it was decided to use one of these. This decision puts a severe constraint on the turbine design, as mentioned earlier, but I feel designing a slower speed high-pressure helium turbine would pose less technical difficulties than a high speed motor design. A good compromise will probably be in the range of 11 to 15 thousand rpm. The generator design chosen comes from a design program written by Jim Davis of MIT [1] His program performs an optimization analysis of water-cooled, electric motors and generators for use in ship propulsion. He analyzed 25,775 HP machines with speeds ranging from 180 rpm to 7200 rpm. It was one of the 7200 rpm design that were chosen. Table 6-2 lists the generator characteristics.

### 6.3.3 Ship Service Generator.

Because of the small size of the ship service generator water cooling adds unnecessary complexity to the design. The ship service generators will therefore be helium cooled. This makes the ship service generator almost the same size as the propulsion generator. Design characteristics were taken from Reference 24 which describes the Toshiba super motor drive system. The difference between motors and generators are generally a matter of application, not design. The motor listed is only intended to get a idea of the size and weight not to be a detailed application. Its characteristics are also listed in Table 6-2.

Table 6-2. Design characteristics of the Marine MGR-GT generators.

	<u>Ship Service</u>	<u>Propulsion</u>
Machine type	Synchronous Helium Cooled	Synchronous Water cooled
Number of Pole pairs	4	4
Shaft RPM	7200	7200
Power (HP/MW)	3400/2.5	25,775/19.2
Synchronous frequency (Hz)	480	480
Rotor radius (m)		.204
Active length (m)		1.08
Overall length (m)	2.0	1.94
Overall diameter (m)	1.0	.57
Weight (kg)	4000	3136
Full load efficiency	.97	.98

## 6.4 Propulsion Motor.

The propulsion motor is the largest mechanical component of the entire system. The requirement for high power with low speed generally requires a large diameter motor. Again with water cooling technology the motor can be made smaller. A design for a 60 Hz 40,000 HP motor is described in reference 23. The characteristics of this motor is listed in Table 6-3.

Table 6-3. Design characteristics of the Marine MGR-GT Propulsion Motor.

---

Machine type	Synchronous-Water cooled
Shaft RPM	0-180
Power (HP)	40,000
Synchronous frequency (Hz)	60
Overall length (m)	4.9
Overall diameter (m)	3.81
Weight (kg)	60100
Full load efficiency	.96

---

## 6.5 Power Conversion Equipment.

In recent years there has been a revolution in power electronics. Rectifiers, controlled converters, inverters, and cycloconverters based on liquid cooled thyristor stacks, have all been developed to the point where their use in a shipboard environment will involve little risk. U.S. manufacturers have supplied many power conditioners to applications in industry at similar power levels for many years therefore little problem is seen in performing the power conversion necessary to control the motor or provide ship service power. In reference 23 a water cooled frequency changer/power converter for a surface ship application. The

characteristics of the power converter is given in Table 6-4. Each power converter module consists of six semi-conductor devices arranged in a stack. Each thyristor is located between two liquid cooled heat sinks. The cooling system uses deionized water to control corrosion. Each of these units can handle 15 MW so only one unit is required per module.

Table 6-4. Power Converter Characteristics.[23]

---

Type:	Converter-Inverter with DC link, line commutated.
Rating:	15 MW, 6300V ac supply
Weight:	22,700 lbs. (10300 kg)
Auxiliaries:	Deionized cooling water; uninterruptable power supply
Size:	L - 260" (6.6 m) W - 54" (1.4 m) H - 84" (2.1 m)

---

## Chapter 7 Control and Control Systems.

This chapter will briefly discuss the methods of control available for this power plant. Reactor control will be discussed first then power plant control and speed control.

### 7.1 Reactor Control.

The primary method of reactor control will be through the negative temperature coefficient. This will ensure that reactor power will follow load over the entire power range. Reactivity control is needed at start up, to set reactor outlet temperature and to compensate for burn-up and Xenon build up. Once temperature is set and the reactor is at steady state it will automatically and quickly follow load changes while maintaining basically constant temperature.

Because of the height of the reactor core and pressure vessel control rods could not be used. For that reason, reflector/absorber drums are installed around the edge of the reactor core. The drums extend the length of the core and are 40 cm in diameter. They are constructed of nuclear graphite in a light steel container. The steel supports the graphite and provides a wear surface for the drum supports. The current design uses 16 drums spaced evenly around the edge of the core. Figure 4-8 and 4-9 show the proposed lay out. This design is for illustration only. Reactor control calculations were not performed because it was not deemed necessary at this point in the design. The control system shown illustrates some features which will probably be necessary once more a more detailed analysis is performed.

Table 7-1 lists some of these design considerations.

Table 7-1. Reactor plant control system design considerations.

- Since the core is batch refueled a large reactivity control margin is needed to compensate for burn-up and allow control at end of life.

- The drums are relatively large so the reactivity difference between positions is significant.
- The drive mechanism is in a pressurized housing with no mechanical seals, this is to prevent helium leakage.
- The control drums are cooled by the compressor discharge flow which sweeps the reactor vessel.
- Control drives should be designed so that power is required to keep the drums in the 'out' position. In that way if control power is lost the drums will automatically rotate into the core, (passive scram on loss of control power)
- Power peaking will be high in an edge controlled reactor. If later studies show unacceptable peaking with peripheral control drums, in core control rods will be necessary. Possibly inserted from the side. Material selection for in core rods will be difficult given the high temperatures.

## 7.2 Power Plant Control.

Since the reactor heat source provides an effectively constant turbine inlet temperature, the only two effective control methods available are turbine bypass or inventory control. Both methods work by adjusting the mass flow rate through the system. Bypass control is effective at all power levels, however since the heat source sees basically a constant load, bypass control is very inefficient during off design point operations. Inventory control, on the other hand, reduces mass flow by lowering system pressure. The advantage is plant efficiency remains relatively constant over the full range of inventory control. The major disadvantage is that it requires a large storage volume to contain the removed inventory. For any practical system both bypass and inventory control systems must be used.

The range of control of each system depends on the volume available for control inventory vessels, the speed of response desired, Control valve size, and the operating profile. The operating profile is important because it determines how much time the system spends at off design points. According to GENSPECS a typical naval vessel is expected to have the following speed-time profile while at sea.

Table 7-2. Speed-time profile for naval vessels.

<u>Speed</u>	<u>Time at or below speed (%)</u>
1/4	9%
1/2	23%
3/4	38%
Full	25%
Flank	5%

Since the ship spends most of its time at 3/4 power and 68% of the time above the 50% power level, 50% is a reasonable lower limit for inventory control with bypass control below 50%. This will require inventory control vessels capable of storing half of the full system inventory. A passive transfer system (Bleed off at compressor discharge, injection at compressor inlet) would reach its storage capacity when storage vessel pressure is equal to compressor discharge pressure. Since most of the primary volume is at or near compressor discharge pressure this method of inventory control would require a storage volume approximately equal to the entire primary system volume to achieve 50% control. This is obviously unacceptable in a volume limited ship design.

Required storage volume can be reduced if helium is pumped out of the system using transfer compressors. This allows the inventory control vessels to be at a higher pressure, thus reducing volume. The power necessary to run the transfer compressors is the controlling factor in this design. For a power decrease, the system is operating at a higher power level than is required. This power can be used to run the transfer compressors. For a power

increase, the storage vessels will be at a higher pressure than the primary system so no pumping power is needed until the primary system and the storage vessels equalize. A storage system pressure of twice the system pressure at 50% power level, reduces the required storage volume by half. Although the detail of such a process have not been worked out the trends are at least in the right direction. The capacity and response time for such a system will have to be the subject of a future study.

reactor.

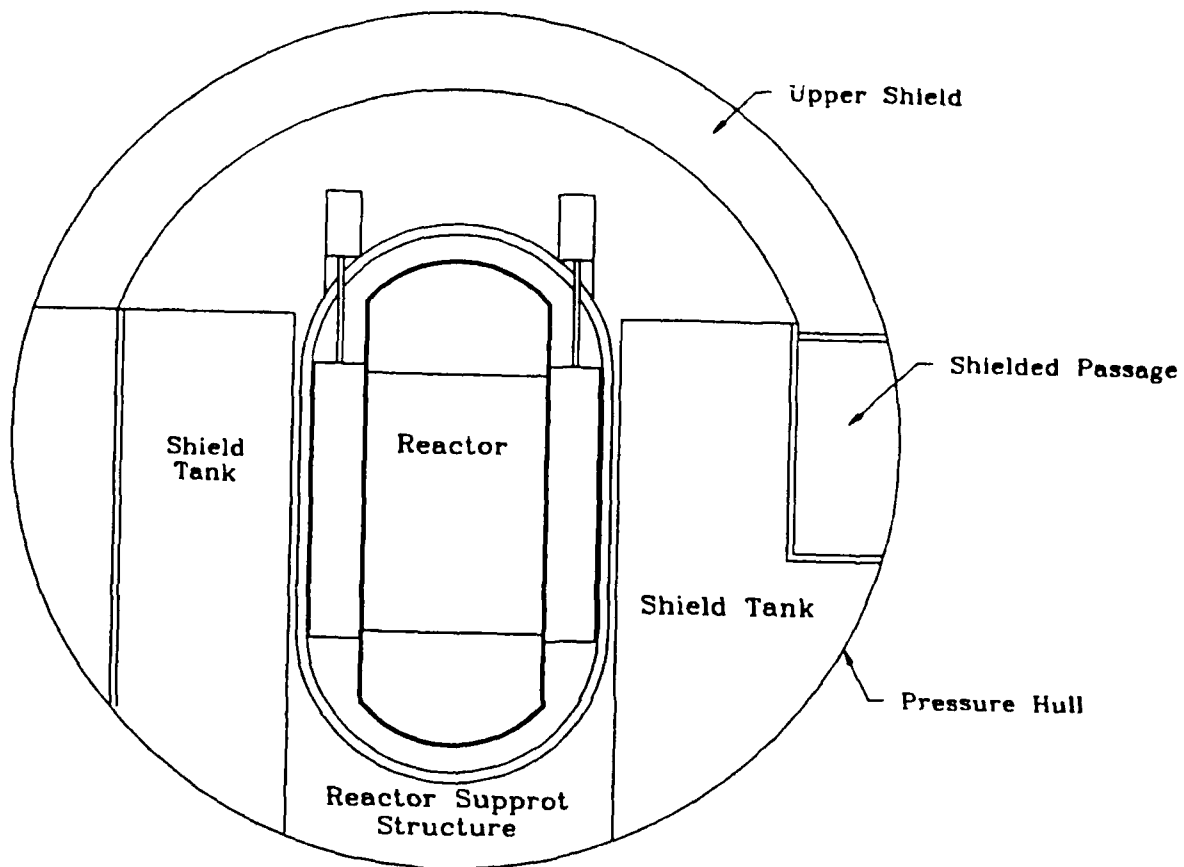

Figure 8-1. Section through Reactor Compartment. (Submarine)

### Marine MGR-GT Reactor Compartment Top Profile

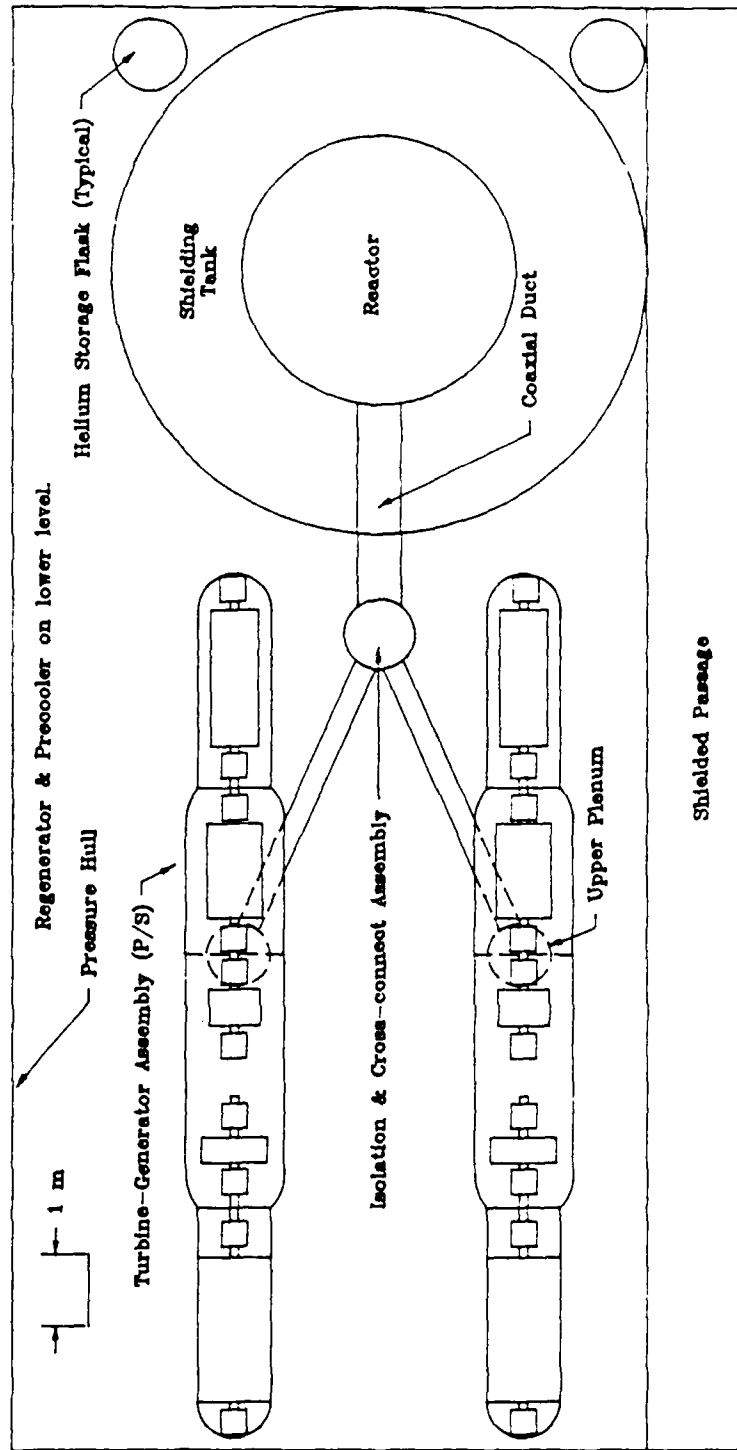

Figure 8-2. Top view of marine MGR-GT Reactor compartment.

### Marine MGR-GT Reactor Compartment Side Profile

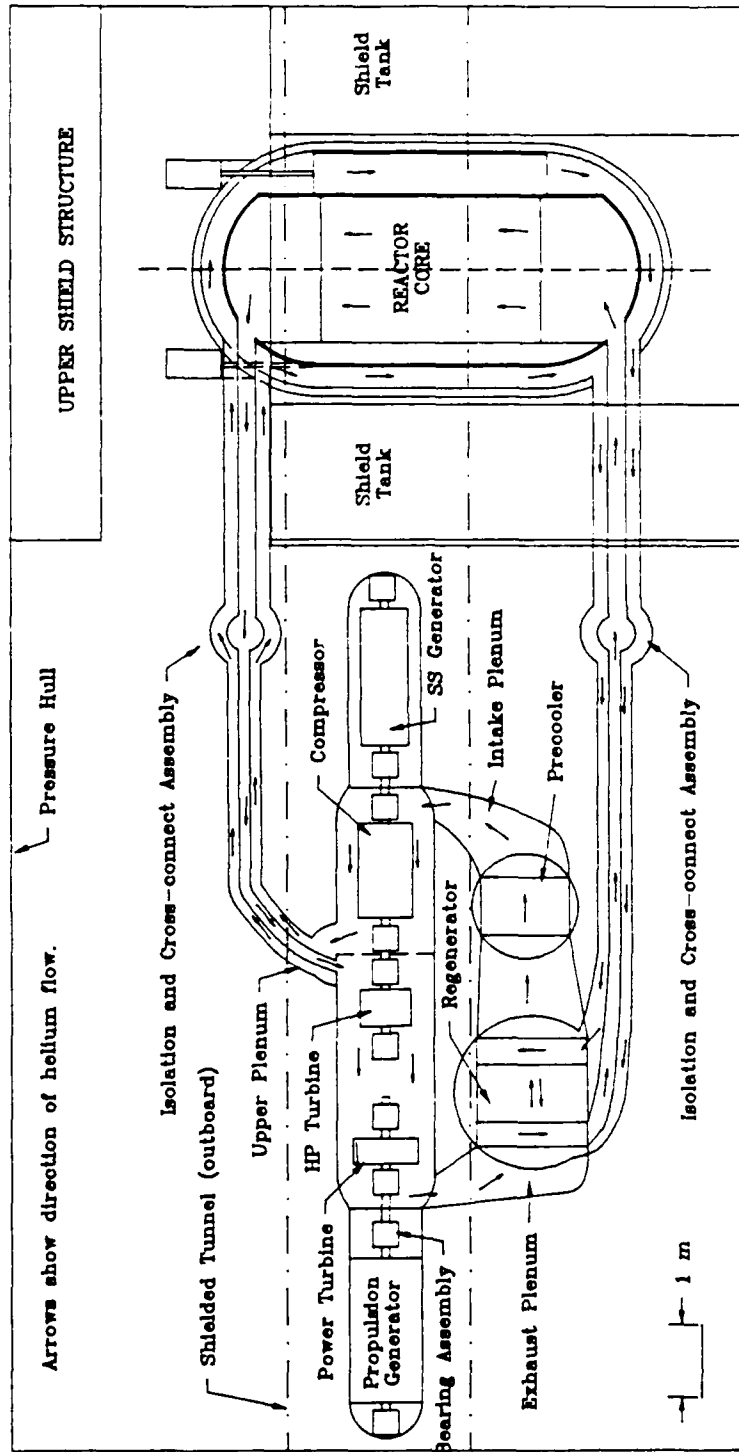

Figure 8-3. Side profile of marine MGR-GT RC showing helium flow path.

## 8.2 Component Summary

This section summarizes the major component designs:

**Reactor.** The reactor is an 80 MWth helium-cooled pebble bed reactor. The major characteristics are:

- **Passive safety.** The system is capable of withstanding a loss of coolant accident without system damage, by rejection of decay heat into the shielding water tank and ultimately into the sea.
- **Coolant pressure** at 8.2 MPa with a core exit temperature of 850°C.
- **Coolant flow path** which sweeps the pressure vessel with relatively low temperature helium. This cools the pressure vessel and allows current ASME pressure vessel codes to be used.
- **Potential for quick batch refueling** without major disassembly.
- **High negative temperature coefficient** at all power levels promotes stable operation
- **Reflector/absorber drums** used for reactivity control.
- **Size:** Vessel is 6.7 m high and 3.7 m in diameter.

**Shielding.** Reactor shielding consists of a 1.8 m water tank which acts as a neutron shield. The reactor vessel is surrounded by a 25 cm thick lead gamma shield. The shield is designed to limit exposure to .5 mR/hr at the shield surface.

**Electric Plant.** The electric plant is an integrated ship propulsion system that provides both propulsive power and ships service power from the same prime mover. Power is generated at high frequency (480 Hz) and is converted to 60 Hz using solid state frequency converters and power conditioners. The main propulsion motor (40,000 HP) is driven by two propulsion generators through a water-cooled, thyristor based, frequency converter. Both the main motor and the propulsion generators use water cooled stators and rotors to reduce size

and weight. The ships service generators are cooled by high pressure helium. The electrical system provides flexibility in that ships propulsion generators can provide ships service power if required. Table 8-1 summarizes the electrical power plant components.

**Closed Brayton Cycle.** The system is powered by a highly recuperated Closed Brayton Cycle. The equipment configuration chosen is a split shaft system with the compressor, ship service generator, and the high pressure turbine on one shaft, and the low pressure, or power turbine, and propulsion generator on the other shaft. All components are enclosed in a common casing and are supported by active magnetic bearings. The split shaft arrangement decouples ship service power generation from the propulsion bus, and it facilitates reactor start up by allowing the ship service generator to act as a motor to power the compressor, thus circulating helium until the reactor gets to power. The power for start-up would be provided by the emergency generators or shore power. The system heat exchangers feature low specific pressure drop, <3%, and high effectiveness. The regenerator is a compact plate-fin arrangement while the pre-cooler is a shell and tube heat exchanger to facilitate repairs and inspections. The Brayton cycle components are also summarized in Table 8-1.

Table 8-1. Marine MGR-GT Plant Parameters and Equipment Summary.

<u>Turbomachinery</u>			
	<u>Turbine</u>		<u>Compressor</u>
	<u>HP</u>	<u>Power</u>	
Stages	4	3	15
RPM	7200	7200	7200
Pressure* (MPa)	8.1	5.1	8.2
Temperature (°C)	850	717	30
Tip Diameter (cm)	68.4	86.2	73.3
Bladed length (cm)	42.0	31.5	130
Poly. Eff.	.9	.9	.9
<u>Heat Exchangers</u>			
	<u>Precooler</u>		<u>Regenerator</u>
Surface (ref 11)	S-1.50-1.25		1/9-24.12 (both sides)
Volume (m <sup>3</sup> )	1.08		3.75
Length (m)	.756		1.5
Frontal Area (m <sup>2</sup> )	1.43		2.5
Weight (kg)	1500		10400
Relative Pres. Drop	.0025		.0252
Effectiveness	.93		.949
<u>Electrical Components</u>			
	<u>Generator</u>		<u>Propulsion</u>
	<u>SS</u>	<u>Prop.</u>	<u>Motor</u>
Cooling	He	Water	Water
Number of Pole Pairs	4	4	
Shaft RPM	7200	7200	0-180
Frequency	480	480	60
Power (HP/MW)	3400/2.5	25,775/19.2	40,000
Length (m)	2.0	1.94	4.9
Diameter (m)	1.0	.57	3.8
Weight (kg)	4000	3136	60100
Full load efficiency	.97	.98	.96

\* Pressure is at turbine inlet or compressor outlet.

### 8.3 Weight Summary.

This section summarizes the weight estimates for the reactor compartment components studied above. These weights are for the component only. They do not include foundations, supports, piping, insulation, valves, or the weight of fluid and support equipment.

Table 8-2. Reactor Compartment Component Weight Summary.

Component	Number Installed	Total Weight (tons)	Remarks
Reactor	1	105	
Shielding	1	490	Lead-water shield completely surrounding reactor.
Regenerator	2	20.8	10.4 each
Precooler	2	3	1.5 each
Turbomachinery	2	<u>26</u>	
Subtotal		644.8	

As can be seen above the estimated weight of the reactor plant components alone is over 600 tons. Most of this is reactor shielding. This weight must be reduced in order to have a viable design.

## Chapter 9 Conclusions and Closing Remarks.

There have been many studies of using nuclear gas turbines on board ship. They have all concluded that the system warranted further study, but the technology just was not to the point where it was feasible at the time. This particular design can say the same thing to a point. The technology to support a closed Brayton cycle and electric propulsion either exists or will exist in the near future. The ability to create low-pressure drop, highly effective compact heat exchangers and the continued refinement and development of magnetic bearings removes the major disadvantages of the closed Brayton cycle that many previous studies have focused on. Advances in power electronics brings effective electric propulsion technology within reach. Everything is in place except the heat source.

As this design stands the reactor heat source is too big and too heavy to be practical on smaller ships (submarines, frigates, and destroyers.) While it is true that some weight and volume is saved outside of the reactor, any gain is more than offset by the weight and size of the core and its required shielding. In Reference 17 Hsu states that an acceptable maximum weight for a reactor subsystem (core and shielding) is 300 tons. Assuming this is true the marine MGR-GT is over 200 tons too heavy. Unless the reactor can be made smaller this system will not be suitable for shipboard use.

I feel the major driver in the reactor size is passive safety (including water ingress). While there is no question that passive safety in a civilian power plant is worth almost any design compromise to achieve, the same thing may not be true of naval power plants. Although passive safety should certainly be a goal, it cannot be sought at the expense of all else. The bottom line is that any good ship design is the result of compromise. The system must be safe, but it must also work.

## 9.1 Areas for Future Study.

Most of the future study needs to be on size reduction for the reactor heat source and concurrently the radiation shield. The following summarizes the areas that effect core size and some possible solutions.

**Reactor Size.** Reactor criticality studies were performed using a two group approximation and the NGC program. The cross sections used in the calculations came from the MHTGR. The MHTGR is a five region cylindrical reactor with an annular core and using prismatic fuel. Although the flux averaging used to calculate the cross sections cannot be the same for this design they were considered close enough for preliminary studies and to get rough sizes. Before more detailed studies could be conducted more accurate cross sections applicable to pebble bed reactors need to be developed.

**Enrichment.** Cross sections used in NGC corresponds to an enrichment of 7%. Once more accurate cross sections are developed, the effects of various enrichments can be studied. The goal here is to reduce reactor size and to ensure enough excess reactivity is loaded at beginning of life to last until the next refueling and to provide Xenon override.

**Water Ingress.** The water ingress problem is the one potential Achilles' Heel in the system. Much further study is required in this area, for if the core cannot tolerate a core flooding casualty, it cannot be considered a feasible design.

**Fast Core.** Of all the possible solutions to the problem of core size I feel that going to a fast spectrum core could be the best solution. Fast cores are small and very power dense and generally have a high burnup and a long life. Water ingress is not a problem as far as reactivity is concerned, if the spectrum is softened by water ingress the reactor will simply shut down instead of the reactivity insertion caused in the Pebble bed core. The main ques-

tion that needs to be answered is whether such a core can be made passively safe. Without the thermal mass of the graphite temperature changes will probably be very rapid. The question is can heat be radiated away rapidly enough to prevent fuel damage.

**Plant Control.** More work needs to be done on how inventory control on a system with more than one turbine-compressor group would work. Questions to be answered are: what are the response times, can the two systems be operated independently or must they always portion the load equally, what is the optimum volume and pressure of the storage vessels, and the mass capacity of the compressors to get the desired response.

**High-Speed Generator/Lower Speed Turbine.** It was discussed in Chapter 5 that applying the turbine scaling equations produced either turbomachines that were too large or rotated too fast to design a reasonable generator without using reduction gears. More study needs to be done on optimizing the generator-turbine combination. There should be some combination of rpm, number of stages, and system pressure that produces an acceptable generator and turbine.

**Bibliography**

- 1 Davis, J.C., **A Comparative Study of Various Electric Propulsion Systems and Their Impact on a Nominal Ship Design.** Engineer's Thesis, Ocean Engineering Department, MIT. June 1987.
- 2 Goldsmith, M.S., **Evaluation of a Gas-Cooled Fast Breeder Reactor for Ship Propulsion.** Engineer's Thesis, Department of Nuclear Engineering, Massachusetts Institute of Technology. August, 1972.
- 3 Izenson, M. G., **Effects of Fuel Particle and Reactor Core Design on Modular HTGR Source Terms.** MITNPI-TR-012, October, 1986.
- 4 Mahoney, D. P., **An Evaluation of a Nuclear Power Plant for a Surface Effect Ship.** Engineer's Thesis, Ocean Engineering Department, MIT, May 1977.
- 5 Nightingale, R.E., ed. **Nuclear Graphite.** Academic Press, New York. 1962.
- 6 Polmar, N., **The Ships and Aircraft Of the U.S. Fleet, Twelfth Edition.** United States Naval Institute, Annapolis MD, 1983.
- 7 Sanchez, R.G., **Passive Heat Removal: Sensitivity Study for Modular Pebble Bed Reactors.** MITNPI-TR-015, Massachusetts Institute of Technology. January 1987.
- 8 Staudt, James E., **Design Study of an MGR Direct Brayton-Cycle Power Plant.** MITNPI-TR-018, Massachusetts Institute of Technology. May 1987.
- 9 **General Specifications for Ships of the United States Navy.** Department of the Navy, Naval Sea Systems Command. 1987 edition.
- 10 Pitts, Donald R., and Sissom, Leighton E. **Theory and Problems of Heat Transfer.** Schaum's Outline Series, McGraw-Hill Book Co., New York. 1987.
- 11 Kays, W. M., and London, A. L. **Compact Heat Exchangers, Third Edition.** McGraw-Hill Book Company, New York. 1984.
- 12 Ness, Jon C. "Computer Program for Performance and Sizing Analysis of Compact Counter-Flow Plate-Fin Heat Exchangers." David W. Taylor Naval Ship Research and Development Center report PAS 82-41. December 1982.
- 13 Goodman, J. Jovanovic, V., Ganley, J., And Covert, R. **The Thermodynamic and Transport Properties of Helium.** General Atomics report No. GA-A 13400, General Atomic Company. October 1975.

- 14 Simnad, M., and Zumwalt, L. Editors. **Materials and Fuels for High-Temperature Nuclear Energy Applications.** Proceedings of the National Topical Meeting of the American Nuclear Society, San Diego, April 11-13, 1962. The MIT Press, Cambridge, Mass. 1962.
- 15 Tanker, Ediz. Personal correspondence and a copy of NGC.
- 16 GA Technologies Inc. Letter to Dr. Allen Henry of MIT describing the MHTGR Core and listing the Macroscopic and Microscopic cross sections. August 14, 1987.
- 17 Hsu, C, and Shu, H, "Energy Sources and Converters." **Proceedings of the Submarine Technology Workshop.** University of Rhode Island, 13-14 Aug 1974. Pages 111-153.
- 18 McDonald, Colin F. "Active Magnetic Bearings for Gas Turbomachinery in Closed-Cycle Power Plant Systems." ASME paper number 88-GT-156, June 1988.
- 19 Shepard, L.R. "Modular High-Temperature Gas-Cooled Reactor." **Nuclear Energy.** Vol. 27, No. 1 Feb. 1988, 37-47.
- 20 Hendrickson, T.A.; Leonard, J.S.; and Weise, D.A. "Application of Magnetic Bearing Technology for Vibration Free Rotating Machinery." **Naval Engineers Journal,** May 1987, 107-111.
- 21 Martin, J.L., Lanning, D.D., Lidsky, L.M. "Modular Gas Reactor "Lift-off" Source Term: Data Needs and Experimental Plans." MIT Report, 1988.
- 22 Class notes, MIT Course 13.21, "Ship Power and Propulsion." 1988.
- 23 Jolliff, J.V., and Greene D.L. "Advanced Integrated Electric Propulsion: A Reality of the Eighties." **Naval Engineers Journal,** April 1982. Pages 232-252.
- 24 Tanaka, H. "Super Motor Drive System", Toshiba Corporation sales pamphlet.

## Appendix A Heat Transfer Program.

The depressurized loss of coolant accident was analyzed using the program HEAT.BAS. HEAT.BAS is a general purpose code that solves the one-dimensional transient heat conduction problem for any axi-symmetric cylindrical body. It is written in Quick-BASIC Version 4.5 and runs on personal computers. The program is based on the method outlined by Sanchez in his report *Passive Heat Removal: Sensitivity Study for Modular Pebble Bed Reactors*. [7]

### A.1 Program Theory and User Guide.

The program uses the modified explicit method to solve the transient problem. In this method the object to be analyzed is partitioned into radial nodes. A heat balance between nodes is performed and the change in temperature for each node at the desired time step is calculated. This process is repeated for each node at every time step. After each time step the nodal temperatures are saved and become the initial conditions for the next iteration.

The program assumes that the outermost node is at constant temperature and the center-line temperature is the same as the temperature of the first node. This corresponds to a constant temperature exterior boundary condition and a zero heat flux central boundary condition. This sets the boundary conditions for the problem.

The Equation A-1 is the heat balance equation used in the normal explicit method. It basically states that the temperature at any node  $j$  at one time step in the future is the temperature it is now plus the change in temperature due to the net heat added to or removed from the node. There are three heat addition terms. The first two are the heat flow from the two adjacent nodes and the third is the heat generation term.

$$T_j(t + \delta t) = T_j(t) + \frac{\delta t}{C_j} \{ K'_{j-1} [T_{j-1}(t) - T_j(t)] + K'_{j+1} [T_{j+1}(t) - T_j(t)] + Q_j \} \quad \text{A-1.}$$

$K_i^j$  is the effective heat transfer coefficient from node i to node j,  $C_j = (\rho C_p V)_j$  and contains the material properties of node j.  $Q_j$  is the heat generation rate and includes the decay heat fraction  $f(t)$ , t in seconds.

$$Q_j = q_0 f(t) V_j \quad \text{A-2.}$$

$$f(t) = .0622[t^{-2} - (t + 3.184 \times 10^7)^{-2}]$$

$$V_j = \pi(r_j^2 - r_{j-1}^2) \quad \text{A-3.}$$

Two types of heat transfer between nodes are allowed, conduction, and radiation. The program handles this by using two different methods to calculate the effective linear thermal conductance between nodes ( $K_i^j$ ). The program determines the type of heat transfer from the input file.

$K_i^j$  for conductive heat transfer between nodes is estimated using the following formula [10]:

$$K_i^j = \frac{2\pi k}{\ln \frac{r_j}{r_i}} \quad \text{A-4.}$$

which is the formula for heat conduction through a hollow cylinder. k is the thermal conductivity of node j,  $r_i$  and  $r_j$  are the radii of nodes i and j.

For radiation heat transfer between nodes (such as across a helium gap) the equation for radiative heat transfer between concentric cylinders is used. (Equation A-5) [10]

$$K_i^j = \frac{2\pi r_j \sigma}{\frac{1}{\epsilon_j} + \frac{1 - \epsilon_i}{\epsilon_i} \cdot \frac{r_j}{r_i}} \cdot \frac{T_i^4 - T_j^4}{T_i - T_j} \quad \text{A-5.}$$

where  $r$  is nodal radius,  $\sigma$  is the Stefan-Boltzmann constant, and  $\epsilon$  denotes the emissivity of the surface. Since radiation is a surface effect, the effective volume of a radiation node is the not the volume between the nodal radii (Equation A-3) but it is based on the  $t_{\max}$  formula (equation A-8). The desired time step is substituted for  $t_{\max}$  and the equation is solved for volume. This method ensures a stable solution and models the heat transfer more accurately.

The modification to the explicit method uses the following equation to achieve a stable solution using larger time steps than would normally be allowed by the normal explicit method. [7]

$$T_j(t + \delta t) = T_j(t) + \frac{1}{1 + Z_j} \left( \frac{\delta t}{C_j} (K_{j-1}^j (T_{j-1}(t) - T_j(t)) + K_{j+1}^j (T_{j+1}(t) - T_j(t)) + Q_j) + Z_j (T_j(t) - T_j(t - \delta t)) \right) \quad \text{A-6.}$$

where  $T_j(t)$  is the temperature at node  $j$  at the current time,  $T_j(t + \delta t)$  is the temperature at node  $j$  one time step in the future,  $T_j(t - \delta t)$  is the temperature at node  $j$  one time step in the past.

$Z_j$  is a factor which is supposed to provide a stable solution at any time step. However, during trial runs in HEAT.BAS the range of stability was increased by only a factor of about two. For example, if a two second time step was stable using the unmodified method then a four second time step was usually stable with the modified equation.  $Z_j$  is a smoothing factor which performs a weighted average of the temperature change over more than one time step. This smoothing factor does not provide absolute stability but it does delay the onset of instability and reduces the oscillation amplitude after instability develops.

$Z_j$  is defined as follows:

$$Z_j \equiv \begin{cases} \frac{1}{2} \left( \frac{\delta t}{(\delta t_{\max})_j} \right), & \text{if } \frac{\delta t}{(\delta t_{\max})_j} > 1 \\ 0, & \text{if } \frac{\delta t}{(\delta t_{\max})_j} \leq 1 \end{cases} \quad \text{A-7.}$$

$$\delta t_{\max} = \frac{(\rho C_p V)_j}{K'_{j-1} + K'_{j+1}} \quad \text{A-8.}$$

$t_{\max}$  is the time step which will provide a stable solution. It is a function of the material properties of the node and the nodal volume  $V_j$ .

## A.2 Materials.

HEAT.BAS uses the following codes to designate the material for each node. The program uses the material code to calculate the temperature dependent thermal property for each node. Where correlations or mathematical models are available they are used. If no equation is available, tabular data is used and the properties are determined by linear interpolation for the desired temperature.

Table A-1 List of material codes and material used in HEAT.BAS.

Material Code	Material
0	Core pebbles
1	Graphite
2	304 stainless steel)
3	2 1/4 Cr Mo steel
4	Helium
5	Reflector to core interface
6	Test Material (Constant Material properties)

The method of calculation and equations used for each of the materials listed in Table A-1 are as follows.

**Core Pebbles.** The core pebbles' thermal conductivity is calculated using the modified Zehner-Schluender model. This model is valid for high temperatures and includes radiation between the pebbles and conduction through the pebbles. [7]

$$\lambda_{eff} = \left\{ (1 - \sqrt{1 - \phi})\phi + \frac{\sqrt{1 - \phi} \left( \frac{B_z + 1}{B_z} \right)}{\left( \frac{2}{\epsilon} - 1 \right) \left( 1 + \frac{1}{\left( \frac{2}{\epsilon} - 1 \right) \Lambda_f} \right)} \right\} 4\sigma T^3 d$$

A-9.

$$B_z \equiv 1.25 \left( \frac{1 - \phi}{\phi} \right)^{\frac{10}{9}}$$

$$\Lambda_f \equiv \frac{\lambda_f}{4\pi\sigma T^3 d}$$

$$C_p = (1 - \phi)C_p^g + \phi \cdot C_p^{He} \quad \text{A-10.}$$

$$\rho = (1 - \phi)\rho_g + \phi \cdot \rho_{He} \quad \text{A-11.}$$

where

- T absolute temperature in °K.
- $\phi$  porosity of pebble bed.
- $\epsilon$  emissivity of pebbles.
- $\sigma$  Stefan-Boltzmann constant.
- $C_p$  specific heat in J/kg·°K. (Superscript indicates either graphite or helium).
- $\lambda_{eff}$  effective thermal conductivity in W/m·°K.
- $\lambda_f$  thermal conductivity of pebble (graphite) in W/m·°K.
- $\rho$  density in kg/m<sup>3</sup>. (subscript indicates either graphite or helium).

**Graphite, 304 Series Stainless Steel and 2 1/4 Cr Mo Steel.** The heat transfer properties of graphite and steel are provided in tabular form. The program uses a subroutine to look up the specific heat and the thermal conductivity of the material as a function of temperature. Linear interpolation is used to obtain values between the tabulated temperatures. Densities were

considered constant at  $1700 \text{ kg/m}^3$  for graphite,  $7800 \text{ kg/m}^3$  for 304 stainless steel, and  $7675 \text{ kg/m}^3$  for CrMo steel. Figures A-1 and A-2 show the specific heat and thermal conductivity of the various materials as a function of temperature. [7]

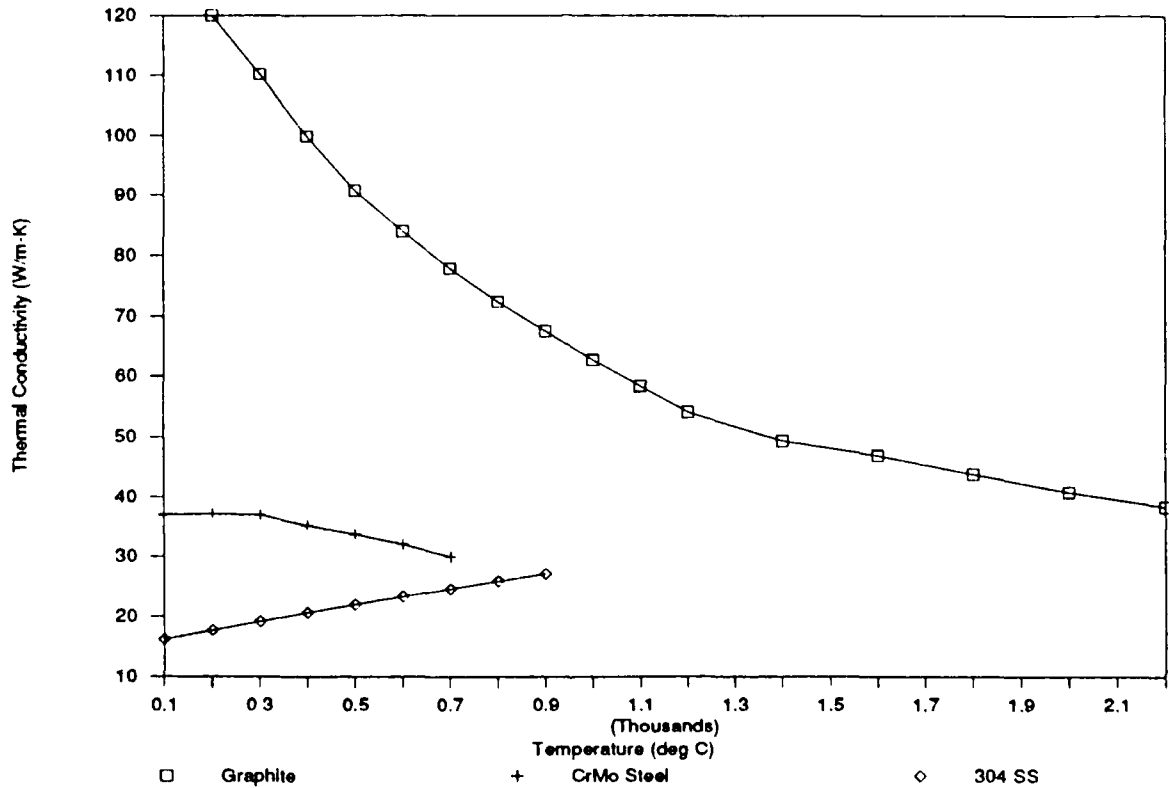

Figure A-1 Thermal conductivity of Graphite, 304 Stainless Steel and 2 1/4 Cr Mo Steel as a function of temperature. [7]

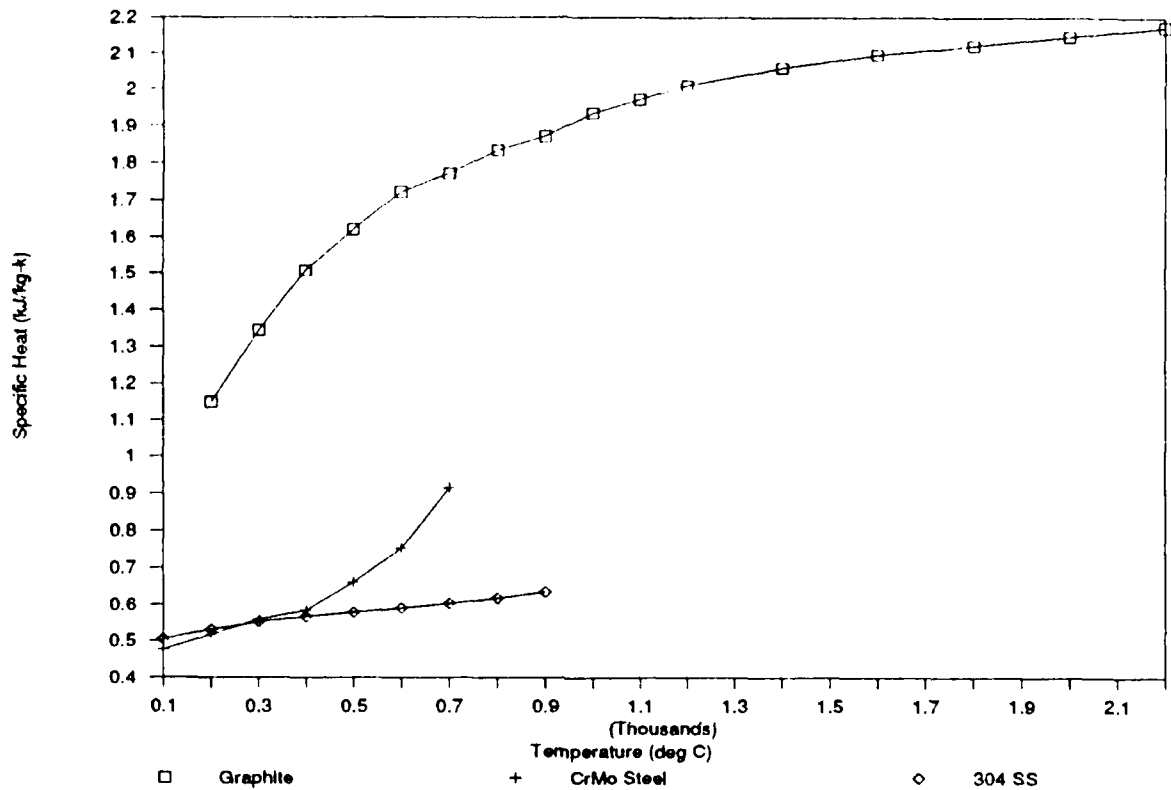

Figure A-2 Specific Heat of Graphite, 304 Stainless Steel and 2 1/4 Cr Mo Steel as a function of temperature. [7]

**Helium.** The thermal properties of helium at atmospheric pressure were calculated using the following correlations and equations. [7]

$$K(P,T) = .002682(1 + .001123P)T^{.71(1 - .0002P)} \quad \text{A-12.}$$

$$C_p = 5195. \text{ J/kg}^\circ\text{K} \quad \text{A-13.}$$

$$\rho(P,T) = \frac{48.14(P/T)}{\left(1 + \frac{.446P}{T^{1.2}}\right)} \quad \text{A-14.}$$

where:

P = pressure in bars.  
T = absolute temperature in °K.  
C<sub>p</sub> = specific heat in J/kg°K.  
K(P,T) = thermal Conductivity in W/m-°K.  
ρ(P,T) = density in kg/m<sup>3</sup>.

### A.3 HEAT.BAS Input File.

The program works with an input file that must provide the following information for each node.

1. The outer radius of the node in meters.
2. The initial temperature in °C.
3. The material code. (See Table A-1) For nodes with conductive boundary conditions the code is for the material to the inside of the nodal radius. If the node is a radiating surface (such as the outer boundary of the pressure vessel) the code is for the material of the surface not the helium.
4. The emissivity on the interior surface of the node. (0 is used for a conductive boundary condition.)
5. The emissivity on the outer surface of the node.
6. The initial heat generation rate (power level) of the node in  $W/m^3$

Table A-2 shows a sample input file. The file is an ASCII file with the entries either in columns (as shown in Table A-2) or separated by commas. The nodal radii do not have to be in order but no two nodes are allowed to have the same radius.

Table A-2. Sample input file for HEAT.BAS

0.05	582	0	0	0	8210000
0.1	580	0	0	0	8150000
0.2	579	0	0	0	8100000
0.4	572	0	0	0	8010000
0.5	565	0	0	0	7600000
0.6	560	0	0	0	7300000
0.7	552	0	0	0	7250000
0.8	544	0	0	0	7240000
0.9	542	0	0	0	6800000
1.01	539.3	0	0	0	6670000
1.06	538.5	0	0	0	7330000
1.12	537	0	0	0	7000000
1.24	536	0	0	0	6870000
1.3	531	0	0	0	6900000
1.35	530	5	0	0	3000000
1.45	425	1	0	0	0
1.55	320	1	0	0	0
1.57	310	2	0	0.6	0
1.77	200	3	0.6	0	0
1.8	185	3	0	0	0
1.85	170	3	0	0.6	0
1.87	50	3	0.6	0	0

## A.4 Source Code Listing for HEAT.BAS

```

*****
/*
/*   one dimensional heat conduction for a cylindrical core
/*
/*   The program requires the initial temperature and power distribution
/*   and solves for the centerline temperature after shutdown with no
/*   normal heat removal
/*
*****

DECLARE SUB DATAPREP ()
DECLARE SUB HEATTRAN (K!, r1!, r!, Temp1!, Temp!, e1!, e2!, q1j!, jK1!)
DECLARE SUB HOPROP (t!, p!, rho!, Cp!, K!)
DECLARE SUB MPROP (t!, Cp!, K!, prop() AS ANY)
DECLARE FUNCTION INTERP! (r!, a!, b!)
DECLARE FUNCTION Keff! (t!, por!, emis!, d!, K!)
DECLARE SUB SORTNODE ()
DECLARE SUB MATPROP (n%, t!, rho!, Cp!, K!)
DECLARE FUNCTION DECAYPOWER! (t!)

'   *****initialization section
DEFINT I-N
CONST pi = 3.141592654#, s = 5.6697E-08, TRUE = -1, FALSE = 0
hepres = 1: rhog = 1700: por = .39: d = .06: emis = .8

TYPE infilerec
    radius      AS SINGLE
    inittemp    AS SINGLE
    mattype     AS INTEGER
    bcin        AS SINGLE
    bcout       AS SINGLE
    initpower   AS SINGLE
END TYPE

TYPE matrec
    Temp        AS SINGLE
    K           AS SINGLE
    Cp          AS SINGLE
END TYPE

'   ***** dimension arrays
DIM SHARED graph(1 TO 16) AS matrec
DIM SHARED ss304(1 TO 10) AS matrec, CrMo(1 TO 8) AS matrec
DIM Temp(100), Told(100), Tnew(100), heat(100), r(100)
DIM mtype(100) AS INTEGER
DIM bcin(100), bcout(100), v(100)
DIM inrec AS infilerec

```

```

      *****Load material property arrays *****
      FOR i = 1 TO UBOUND(graph): '           Graphite
        READ graph(i).Temp, graph(i).K, graph(i).Cp
      NEXT i
      FOR i = 1 TO UBOUND(ss304): '           Stainless steel
        READ ss304(i).Temp, ss304(i).K, ss304(i).Cp
      NEXT i
      FOR i = 1 TO UBOUND(CrMo): '           Cr Mo Steel
        READ CrMo(i).Temp, CrMo(i).K, CrMo(i).Cp
      NEXT i

      SCREEN 0, 0, 0: CLS
      PRINT "ONE DIMENSIONAL TIME DEPENDENT HEAT TRANSFER PROGRAM"
      PRINT "FOR A CYLINDRICAL CORE."
      PRINT

      ***** load problem *****
      name$ = "input.000"
      out$ = "heat.out"
      PRINT "WHAT IS THE NAME OF THE INPUT FILE <" ; name$ ; "> ";
      INPUT x$: PRINT
      IF LEN(x$) <> 0 THEN name$ = x$
      OPEN name$ FOR INPUT AS #1

      ***** find number of nodes *****
      FOR n = 0 TO 100
        IF EOF(1) THEN EXIT FOR
        LINE INPUT #1, r$
        IF r$ = "" THEN EXIT FOR
      NEXT n
      CLOSE 1
      OPEN name$ FOR INPUT AS #1

      ***** load node properties *****
      FOR i = 1 TO n
        INPUT #1, r(i), Temp(i), mtype(i), bcin(i), bcout(i), heat(i)
        Temp(i) = Temp(i) + 273.15
      NEXT i
      Temp(0) = Temp(1)
      PRINT "What is the name of the output file<" ; out$ ; "> ";
      INPUT x$
      IF x$ = "" THEN x$ = out$
      OPEN x$ FOR OUTPUT AS #2
      INPUT "What is the time step"; dt
      CALL SORTNODE: '           ***** sort nodes by radius
      CALL DATAPREP: '           ***** find effective nodal volumes
      *****

      ***** input file loaded and sorted -- start calculations
      t = 0: '           *****set initial time
      ***** start of time loop *****

```

```

DO: ' ***** start with the exterior node and work toward the center
    t = t + dt: ' ***** elapsed time in seconds
    time = t / 3600: ' ***** convert to hours
    ' ***** check for a radiation outer boundry and get
    ' ***** heat transfer coefficients for outer node
    IF bcin(n) = 0 THEN q = .5 * (Temp(n - 1) + Temp(n)) ELSE q = Temp(n)
    CALL MATPROP(mtype(n), q, rho, Cp, K1!)
    HEATTRAN K1!, r(n - 1), r(n), Temp(n - 1), Temp(n), bcout(n - 1), bcin(n), q2j, jK2!
    q2j = -q2j
    /*****
    ' ***** loop thorough nodes *****
    FOR j = n - 1 TO 1 STEP -1
        il = j - 1
        IF bcin(j) = 0 THEN
            ' ***** Conduction only *****
            CALL MATPROP(mtype(j), .5 * (Temp(il) + Temp(j)), rho, Cp, K1!)
            HEATTRAN K1!, r(il), r(j), Temp(il), Temp(j), bcout(il), bcin(j), qlj, jK1!
            ELSE
                ' ***** Radiation node *****
                CALL MATPROP(mtype(j), Temp(j), rho, Cp, K1!)
                HEATTRAN K1!, r(il), r(j), Temp(il), Temp(j), bcout(il), bcin(j), qlj, jK1!
            END IF
            q = heat(j) * DECAYPOWER(t) * v(j): ' ***** calculate decay heat
            ' ***** calculate new temperature for node j
            IF jK1! + jK2! = 0 THEN tmax = dt ELSE tmax = rho * Cp * v(j) / (jK1! + jK2!)
            IF dt / tmax > 1 THEN Zj = .5 * (dt / tmax - 1) ELSE Zj = 0
            Tnew(j) = Temp(j) + (dt * (qlj + q2j + q) / rho / Cp / v(j)) / (1 + Zj) + Zj *
            (Temp(j) - Told(j))
            jK2! = jK1!: ' ***** setup for next node
            q2j = -qlj
        NEXT j
        ' ***** End of node loop ***
        /*****
        ' ***** New temperature distribution has been found *****
        ' ***** print the distribution once an hour to an output file
        ' ***** and check for temperature reduction to end program
        Tnew(n) = Temp(n)
        Told(n) = Temp(n)
        FOR i = 1 TO n
            Told(i) = Temp(i)
            Temp(i) = Tnew(i)
        NEXT i
        ' ***** print every hour
        IF FIX(time) <> FIX(time - dt / 3601) THEN
            PRINT #2, time;
            FOR i = 1 TO n: PRINT #2, USING "#####.##": Tnew(i) - 273.15; : NEXT i
            PRINT #2,
            PRINT time, Tnew(1) - 273.15, Tnew(1) - Thold, telaps - TIMER: Thold = Tnew(1)

```

```

        telaps = TIMER
    END IF
    Told(0) = Temp(0)
    Temp(0) = Tnew(1): ' approximate central boundry condition
    LOOP UNTIL Told(0) >= Temp(0) AND time > 1
'*****end of time loop*****
'
' ***** Central temperature has started to drop end program
PRINT
PRINT "Max Centerline temperature is"; Told(0); " at t ="; time; "hours"
PRINT #2, time;
FOR i = 1 TO n: PRINT #2, USING "#####.##"; Tnew(i) - 273.15; : NEXT i
END
'*****end of main program*****
'
' ***** Data statements for graphite *****
'
'          T          K          Cp
DATA 473.15, 120.      , 1150.00
DATA 573.15, 110.2543, 1344.455
DATA 673.15, 99.89896, 1507.8
DATA 773.15, 90.76186, 1620.885
DATA 873.15, 84.06132, 1721.405
DATA 973.15, 77.96992, 1771.665
DATA 1073.15, 72.48766, 1834.49
DATA 1173.15, 67.61454, 1872.185
DATA 1273.15, 62.74142, 1935.01
DATA 1373.15, 58.47744, 1972.705
DATA 1473.15, 54.21346, 2010.4
DATA 1673.15, 49.34034, 2060.66
DATA 1873.15, 46.90378, 2098.355
DATA 2073.15, 43.85808, 2123.485
DATA 2273.15, 40.81238, 2148.615
DATA 2473.15, 38.37582, 2173.745
'
' ***** data statements for 304 stainless steel *****
'
'          T          K          Cp
DATA 273.15, 14.8      , 470.00
DATA 373.15, 16.199, 504.4492
DATA 473.15, 17.7383, 531.1502
DATA 573.15, 19.2043, 552.0922
DATA 673.15, 20.6703, 567.2752
DATA 773.15, 22.063, 578.7933
DATA 873.15, 23.3824, 591.3585
DATA 973.15, 24.6285, 602.8766
DATA 1073.15, 25.9479, 617.536
DATA 1173.15, 27.194, 634.2896
'
' ***** data statements for 2 1/4 Cr Mo Steel *****
'
'          T          K          Cp
DATA 273.15, 36.2      , 440.
DATA 373.15, 37.0661, 475.384

```

```

DATA 473.15, 37.2755, 516.217
DATA 573.15, 37.0661, 558.6205
DATA 673.15, 35.2862, 585.319
DATA 773.15, 33.8204, 660.703
DATA 873.15, 32.1452, 751.792
DATA 973.15, 30.0512, 915.124
END

```

## SUB DATAPREP

```

'      Data prep subprogram calculates effective nodal volume
SHARED Temp(), Told(), heat(), r(), mtype() AS INTEGER, n
SHARED bcin(), bcout(), v(), dt
FOR i = 1 TO n - 1: '      ***** start loop through nodes
    il = i - 1: ip1 = i + 1
    Told(i) = Temp(i): '      ***** initialize temp history array
    IF bcin(i) <> 0 THEN
'      *****find effective volume of a radiation boundary surface*****
        CALL MATPROP(mtype(i), Temp(i), rho, Cp, K1!)
        HEATTRAN K1!, r(il), r(i), Temp(il), Temp(i), bcout(il), bcin(i), q1j, jK1!
        CALL MATPROP(mtype(ip1), Temp(ip1), rho1, Cp1, K2!)
        HEATTRAN K2!, r(i), r(ip1), Temp(i), Temp(ip1), bcout(i), bcin(ip1), q2j, jK2!
        v(i) = (jK1! + jK2!) / rho / Cp * dt * 1.25
        v(i + 1) = -v(i): '      ***** subtract volume from next node
    ELSE
'      ***** Conduction node
        v(i) = v(i) + pi * (r(i) ^ 2 - r(il) ^ 2)
    END IF
    PRINT i, r(i), v(i)
NEXT i
Told(n) = Temp(n)
'      ***** print file header
FOR i = 0 TO n
    PRINT #2, i; : NEXT i: PRINT #2,
FOR i = 0 TO n
    PRINT #2, r(i); : NEXT i: PRINT #2,
    PRINT #2, 0!;
FOR i = 1 TO n
    PRINT #2, USING "#####.#" ; Temp(i) - 273.15; : NEXT i: PRINT #2,
END SUB

FUNCTION DECAYPOWER (t) STATIC
'      ***** Function calculates the decay power fraction as a function
'      of time in seconds
IF t < 1 THEN
    DECAYPOWER = EXP(-2.809489 * t)
ELSE
    DECAYPOWER = .0622 * (t ^ (-.2) - (t + 3.184E+07) ^ (-.2))
END IF
END FUNCTION

```

```

SUB HEATTRAN (K!, r1, r, Temp1, Temp0, e1, e2, qj, jKl!) STATIC
/
/   ***** calculate the heat transferred from adjacent node
/   input variables
/   k!      Thermal conductivity of node
/   r1     radius of inner node
/   r      radius of node
/   Temp1  temperature of inner node
/   Temp0  temperature of node
/   e1     boundary condition into node (emissivity)
/   e2     boundary condition out of inner node (emissivity)
/   output variables
/   qj     heat transferred from inner node
/   jKl!   effective linear heat transfer coefficient

IF Temp1 - Temp0 = 0 THEN
  qj = 0: jKl! = 0: /   ***** no temperature difference between nodes
ELSE
  IF e2 = 0 THEN
/
/   ***** Conduction only
  qj = 2 * pi * K! / LOG(r / r1) * (Temp1 - Temp0)
  ELSE
/
/   ***** radiation boundary with conduction through helium
/   radiation first
  qj = 2 * pi * r1 * S / (1 / e1 + (1 - e2) / e2 / r * r1) * (Temp1 ^ 4 - Temp0 ^ 4)
  CALL HePROP(.5 * (Temp1 + Temp0), hepres, x, y, Kh!)
  qj = qj + 2 * pi * Kh! / LOG(r / r1) * (Temp1 - Temp0)
  END IF
  jKl! = qj / (Temp1 - Temp0):
  ENI IF
END SUB

SUB HePROP (t, p, rho, Cp, K!) STATIC
/
/   ***** Helium properties as a function of temperature and pressure
/   input variables
/   t      Temperature in 'K
/   p      pressure in bars
/   output variables
/   rho    density in kg/m^3
/   K!     thermal conductivity
/   Cp     Specific heat

rho = 48.14 * (p / t) / (1 + .446 * p / t ^ 1.2)
K! = .002682 * (1 + .001123 * p) * t ^ (.71 * (1 - .0002 * p))
Cp = 5195
END SUB

FUNCTION Keff! (t, por, emis, d, K!) STATIC
/
/   ***** This function computes the effective thermal conductivity
/   through a pebble bed using the modified Zehner-
/   Schulender equation
/   input variables

```

```

'          t      Temperature 'K
'          por    Porosity of pebble bed
'          emis   emissivity of pebbles
'          d      diameter of spheres
'          K!     Thermal conductivity of graphite at temp t
'
Bz = 1.25 * ((1 - por) / por) ^ (10 / 9)
b = 4 * S * d * t ^ 3
gammaf = K! / b / pi
a = 2 / emis - 1
c = SQR(1 - por)
Keff! = b * ((1 - c) / a + c / a * (Bz + 1) / Bz / (1 + 1 / a / gammaf))
END FUNCTION

SUB MATPROP (n, t, rho, Cp, K!) STATIC
' ***** Subroutine to find the various material properties given temp
' the following code is used
' N= 0 Core pebbles
'   1 graphite reflector
'   2 core barrel (currently 302 stainless)
'   3 Pressure vessel (currently 2 1/4 Cr Mo steel
'   4 helium
'   5 Reflector to core
'   6 Test Material (Constant Material properties)

SHARED por, emis, d, hepres, rhog
SELECT CASE n
CASE 0: ' core pebbles
' to find keff for the pebble bed the porosity, emissivity, and
' pebble diameter are defined in the main module
CALL MPROP(t, Cpg, Kg!, graph()): ' graphite properties
K! = Keff!(t, por, emis, d, Kg!)
CALL HePROP(t, hepres, rhoh, Cph, Kh!): ' Helium properties
rho = rhog * (1 - por) + rhoh * por
Cp = (1 - por) * Cpg + por * Cph
CASE 1: ' graphite
CALL MPROP(t, Cp, K!, graph())
CASE 2: ' 302 stainless
CALL MPROP(t, Cp, K!, ss304())
rho = 7800
CASE 3: ' 2 1/4 Cr Mo steel
CALL MPROP(t, Cp, K!, CrMo())
rho = 7675
CASE 4: ' helium
CALL HePROP(t, hepres, rho, Cp, K!)
CASE 5: ' reflector to core interface node
CALL MPROP(t, Cpg, Kg!, graph()): ' graphite properties
pl = por / 2
K! = Keff!(t, pl, emis, d, Kg!)
CALL HePROP(t, hepres, rhoh, Cph, Kh!): ' Helium properties

```

```

        rho = rhob * p1 + rhog * (1 - p1)
        Cp = (1 - p1) * Cpg + p1 * Cph
CASE 6: ' test material (constant material properties)
        Kl = 50
        Cp = 2000
        rho = rhog
CASE ELSE
        PRINT n
        STOP
END SELECT
END SUB

SUB MPROP (t, Cp, Kl, prop() AS matrec) STATIC
' ***** Finds the material properties as a function of temp
'
n = UBOUND(prop)
t1 = prop(1).Temp
IF t < t1 THEN
        Cp = prop(1).Cp
        Kl = prop(1).K
        EXIT SUB
ELSEIF t >= t1 AND t <= prop(n).Temp THEN
        FOR i = 2 TO n
                i1 = i - 1
                IF prop(i).Temp >= t THEN
                        ratio = (t - t1) / (prop(i).Temp - t1)
                        Cp = ratio * (prop(i).Cp - prop(i1).Cp) + prop(i1).Cp
                        Kl = ratio * (prop(i).K - prop(i1).K) + prop(i1).K
                        EXIT SUB: ' <= normal exit
                ELSE
                        t1 = prop(i).Temp
                END IF
        NEXT i
        END IF
        BEEP
        PRINT "ERROR, Temperature out of range of tabulated values"
        PRINT "Temperature ="; t; " Allowable range is"; prop(1).Temp; "to"; prop(i).Temp
        END
END SUB

SUB SORTNODE
' ***** this subroutine sorts the nodes in order of radius
' it also checks for duplicate radii and gives a warning
'
        SHARED Temp(), heat(), r(), mtype() AS INTEGER, n
        SHARED bcin(), bcout()
        FOR i = 0 TO n
                FOR j = i + 1 TO n
                        IF r(j) = r(i) THEN
                                BEEP

```

```
      PRINT "Input file contains two nodes with the same radius"; r(i)
      PRINT "program cannot continue."
      END
    END IF
    IF r(i) > r(j) THEN
      SWAP r(i), r(j)
      SWAP Temp(i), Temp(j)
      SWAP heat(i), heat(j)
      SWAP mtype(i), mtype(j)
      SWAP bcout(i), bcout(j)
      SWAP bcin(i), bcin(j)
    END IF
  NEXT j, i
END SUB
```

## Appendix B Heat Exchanger Analysis.

This section outlines the methods used to design the main system heat exchangers, the regenerators and the precoolers. The regenerators were analyzed using the program COMPHX.BAS and the precoolers were designed using the program PRECOOL.BAS. Both programs were written in QuickBASIC version 4.5 and run on IBM XT type personal computers.

### B.1 Regenerator Design Program COMPHX.BAS

COMPHX.BAS performs a complete analysis of a compact, plate-fin, counter flow heat exchanger with cross flow headers. It performs this analysis using the effectiveness-NTU method [11]. Where effectiveness is defined by either equation B-1 or B-2 and NTU (Number of heat Transfer Units) is a non-dimensional parameter defined in equation B-3.

$$\epsilon = \left( \frac{C_h}{C_c} \right) \frac{T_{h_{in}} - T_{h_{out}}}{T_{h_{in}} - T_{c_{in}}} \quad \text{B-1.}$$

$$\epsilon = \frac{T_{c_{out}} - T_{c_{in}}}{T_{h_{in}} - T_{c_{in}}} \quad \text{B-2.}$$

Where  $C$  is a flow stream capacity rate defined as  $C \equiv \dot{m}C_p$ ,  $\dot{m}$  is the mass flow rate,  $C_p$  is the specific heat,  $A$  is the minimum flow area, and  $U_{av}$  is an average heat transfer coefficient.

$$\text{NTU} = \frac{AU_{av}}{C_{\min}} \quad \text{B-3.}$$

COMPHX.BAS was derived from a program written by Jon Ness as described in Reference 12. It was originally written in FORTRAN IV and was used to predict the

performance of recuperators installed on open cycle marine gas turbines. I have rewritten the program in QuickBASIC to run on personal computers and have added the ability to model non-uniform hot side gas flow conditions, either helium or a fuel-air mixture as the working fluid, and input in either metric or English units.

### B.1.1 Method of Analysis.

There are two different types of heat exchanger analysis. The first (or design problem) takes as input parameters the desired effectiveness, mass flow rate, and pressure drop and produces as output the size required. The second method (or analysis problem) is the inverse of the first method. In this method the size, mass flow rate, and inlet conditions are given and the heat exchanger performance is calculated. The choice of method depends on the specific problem, the first method tends to be better in the initial design phase, while the second is better at predicting the performance of a given design. COMPHX.BAS uses the second method.

The analysis procedure is summarized below:

1. **Define cycle conditions.** Fluid types (helium or air-fuel), mass flow rates ( $\dot{m}$ ), cold side inlet pressure ( $P_{c_m}$ ) and temperature ( $T_{c_m}$ ), hot side inlet temperature ( $T_{h_m}$ ) and outlet pressure ( $P_{h_m}$ ), along with flow velocities define the problem initial conditions.
2. **Select heat exchanger properties.** The user selects the counter flow length  $L$ , total frontal area  $A_f$ , material properties (metal density  $\rho$  and thermal conductivity  $k$ ), plate thickness  $a$ , and core matrix fin geometry. The fin geometry is specified separately for the hot and cold sides since different fin geometries could be used on each side. All necessary surface characteristics (such as plate spacing  $b$ , hydraulic radius  $r_h$ , fin thickness  $\delta$ , ratio of heat transfer area to volume between plates (compactness)  $\beta$ , and ratio of fin area to total area, are from reference 11 and are listed in Appendix C This

- completes the problem definition.
3. **Set up iterations.** Calculate the heat transfer and free flow areas on both sides, and make initial guesses for effectiveness and pressure drop. These initial guess will be iterated through the following steps until the processes converges on the final values.
  4. **Determine temperature dependent fluid properties.** Average hot side and cold side temperatures are used to calculate fluid properties. The assumed effectiveness is used to calculate temperatures based on equation B-1 and fluid properties are calculate using correlations in references 11 and 13.
  5. **Calculate Reynolds number on both sides.** Reynolds number is defined as:

$$N_r = \frac{4r_h G}{\mu} \quad \text{B-4.}$$

where  $G$  is the flow stream mass velocity  $G = \dot{m}/A_c$  and  $A_c$  is the free flow area on one side.

6. **Determine Stanton number  $N_{ST}$ , Colburn factor  $j = N_{ST}N_{PR}^{2/3}$ , and friction factor  $f$**  from the tabulated data from reference 11. The program has tabulated data for Colburn and friction factor as a function of Reynolds number for each of the surfaces in its data base. The desired values at the required Reynolds number are interpolated between the tabulated values.
7. **Calculate the heat transfer coefficient  $h$  using the equation**

$$h = NST \cdot G \cdot C_p \quad \text{B-5.}$$
8. **Calculate the fin effectiveness  $\eta_f$  and surface effectiveness  $\eta_o$  using:**

$$\eta_f = \frac{\tanh ml}{ml} \quad \text{B-6.}$$

$$m \equiv \sqrt{\frac{2h}{k\delta}} \quad \text{B-7.}$$

$$\eta_o = 1 - \frac{A_f}{A} (1 - \eta_f) \quad \text{B-8.}$$

9. Calculate the overall coefficient of heat transfer  $U$ , based on the cold-side area.

$$\frac{1}{U_{av}} = \frac{1}{\eta_o h_c} + \frac{1}{(A_h/A_c)\eta_o h_h} + \frac{a}{k} \quad \text{B-9.}$$

10. Calculate the new NTU and effectiveness. For a counter flow heat exchanger effectiveness is related to NTU by the following [11][12]:

$$\epsilon = \frac{1 - e^{-NTU(1-C_r)}}{1 - C_r e^{-NTU(1-C_r)}} \quad \text{B-10.}$$

In the case where  $C_r = 1$ , such as a closed cycle gas turbine with no bypass flow, the above reduces to the following.

$$\epsilon = \frac{NTU}{1 + NTU} \quad \text{B-11.}$$

This new value for effectiveness is compared with the initial guess. If the effectiveness has changed the new value is used as the initial guess and the process starts again at step 4 above.

11. Once effectiveness has converged the pressure drop is calculated. The pressure drop is composed of three major components: the header pressure drop, core pressure drop, and the bend pressure drop. These pressure losses are dependent on the geometry of the heat exchanger so for this program the configuration shown in Figure B-1 is used. Although the final heat exchanger may not look exactly like B-1 it should be close enough for this stage in the design process.

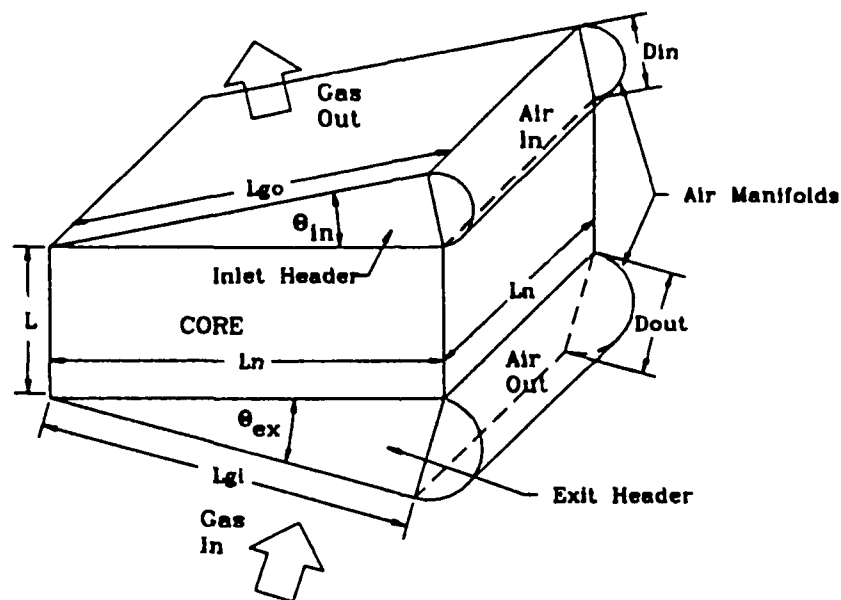

Figure B-1 Regenerator Arrangement Used for Pressure Drop and Weight Estimates.  
[12]

Again the calculated pressure drop is compared to the initial estimate. If it has changed the new pressure drop is used as the initial estimate and the process goes back to step 4. There is therefore two major loops; an outer pressure drop loop and an inner effectiveness loop. When both loops are satisfied the fluid conditions are set and all temperatures and pressures are known.

Of the three components of pressure drop the core loss is the most complicated. The following formula is used to estimate the core drop:

$$\frac{\Delta P_c}{P_1} = \frac{G^2 v_1}{2g_c P_1} \left[ (K_c + 1 - \sigma^2) + 2 \left( \frac{v_2}{v_1} - 1 \right) + f \frac{A}{A_c} \frac{v_m}{v_1} - (1 - \sigma^2 - K_e) \frac{v_2}{v_1} \right] \quad \text{B-12.}$$

The terms in brackets represent the four elements of the core drop: (1) entrance effects, (2) flow acceleration, (3) core friction, and (4) exit effects. In the above the K factors are entrance and exit loss coefficients,  $v_1$  and  $v_2$  is the fluid specific volume at the entrance and exit,  $\sigma$  is the ratio of free flow area to frontal area, and  $f$  is the friction factor from the tabulated data.

Pressure loss in the crossflow headers is handled by increasing the core loss by assuming the headers effectively make the core longer. The headers are triangular wedges so the average length is easily obtained.

Finally, the bend loss occurs where the fluid has to change direction as it moves from the headers into or out of the core. It is estimated by assuming it is a miter elbow with loss coefficient  $K_b$ .  $K_b$  is curve fit from the literature and is used in the same manner as the entrance and exit coefficients above. [12]

After the above is completed the program estimates the weight of the heat exchanger. This estimate is done in five parts: (1) weight of cold side fins, (2) weight of hot side fins, (3) total weight of separating plates, (4) enclosure weight, and (5) header weights.

The weight estimate for the fins and plate is based on the geometry of the fins (from the surface data base), the density of the metal, and core volume and frontal area. From the above data an average core density is determined. Multiply this density by the core volume to obtain core weight. Header density is assumed to be the same as the core so header weight is density times header volume.

Finally, the enclosure weight is based on the surface area. The area density of the enclosure is assumed to be  $15 \text{ lb/ft}^2$  and it includes metal, insulation, and supports. [12] This number obviously will not be good for every application, but it was based on marine gas turbine installations so it should be close.

### B.1.2 Input file for COMPHX.BAS

The input file is an ASCII file which contains all the input data necessary to run the program. It can be created with a pure ASCII text editor or the easiest way is to run the program and input the data manually. COMPHX.BAS will save the input data as a data file.

The file contains the following information:

<u>Line</u>	<u>Data</u>
1	Comment
2	Type of units (1 = English, 2 = Metric)
3	Cold side surface type, surface number, fluid code (1 = air-fuel, 2 = helium)
4	Hot side surface type, surface number, fluid code
5	Metal density, thermal conductivity, and plate thickness.
6	Frontal area, counter-flow length.
7	Cold side mass flow rate, inlet temperature, inlet pressure, and header velocity.
8	Hot side mass flow rate, exit pressure.
9	Number of horizontal nodes, number of vertical nodes.
10-?	Hot side velocity and inlet temperature for each node.
Last	Cold side and hot side fuel-air ratio.

Table B-1 Sample Input File for COMPHX.BAS

```
STRIP FIN SURFACE 1/9-24.12  
2  
3,17,2  
3,17,2  
7832.8,16,.1  
2.5,1.5  
27.4,417.1,8.2,30  
27.4,4.01  
1,1  
1,878.7  
0,0
```

## B.1.3 Sample Output from COMPHX.BAS

## COMPACT HEAT EXCHANGER ANALYSIS

RUN # 1 INPUT FILE 3\_17.IN

1 x 1 NODES

STRIP FIN SURFACE 1/9-24.12

CORE HEAT TRANSFER SURFACE

COLD-SIDE

HOT-SIDE

FIN TYPE

STRIP

STRIP

FIN AND SURFACE NUMBER

3-17

3-17

Fins/cm

9.496044

9.496044

FIN LENGTH (cm)

4.374007E-02

4.374007E-02

PLATE SPACING (cm)

.1905004

.1905004

HYDRAULIC RADIUS (cm)

3.025146E-02

3.025146E-02

FIN THICKNESS (cm)

1.016002E-02

1.016002E-02

COMPACTNESS (m<sup>2</sup>/cu m)

2831.365

2831.365

FIN/TOTAL AREA (m<sup>2</sup>/m<sup>2</sup>)

.857

.857

FLUID TYPE

HELIUM

HELIUM

LENGTH = 1.5 m

VOLUME = 3.749999 cu m

FRONTAL AREA = 2.5 m<sup>2</sup>

HEIGHT = 2.377325 m

METAL DENSITY = 7832.8 kg/cu m

WEIGHT = 10448.79 kgs

PLATE THICKNESS = .1 cm

K = 16 W/m-°K

## COLD HEADER DESIGN DETAILS

INLET

EXIT

DIAMETER (m)

.3504919

.5268331

VELOCITY (m /sec)

30

27.41736

## HEAT EXCHANGER CONDITIONS

COLD-SIDE

HOT-SIDE

INLET

EXIT

INLET

EXIT

PRESSURE (MPa)

8.2

8.141543

4.082453

4.01

TEMPERATURE (°K)

417.1

855.1212

878.7

440.6789

MASSFLOW (kg/sec)

27.4

27.4

PRESSURE DROP (%)

.7128874

1.806785

PRESSURE DROP (in H2O)

234.7874

296.2564

HOT SIDE WALL TEMPERATURE (°K)

867.5189

429.4602

REYNOLDS NUMBER

1134.089

1822.023

Tw-Tg (°K)

11.18117

11.21867

EFFECTIVENESS = 94.89191 %

NTU = 18.57682

TOTAL PRESSURE DROP = 2.519673 %

## B.1.4 Source Code Listing for COMPHX.BAS

```

*****
'      WRITTEN BY RICHARD D. LANTZ.   3-14-89
'      THIS PROGRAM PERFORMS COMPACT HEAT EXCHANGER PERFORMANCE AND
'      SIZING CALCULATION USING METHODS AND EMPIRICAL DATA FROM KAYS
'      AND LONDON'S "COMPACT HEAT EXCHANGERS".  THIS PROGRAM IS BASED
'      ON A PROGRAM WRITTEN BY JON NESS AS PUBLISHED IN DTNSRDC
'      REPORT PAS 82 - 41.
'      THE PROGRAM WAS WRITTEN IN QUICK BASIC AND IT ALLOWS
'      INTERACTIVE MODIFICATION OF INPUT PARAMETERS, THE USE OF AN INPUT
'      FILE, ALLOWS SAVING OF INPUT PARAMETERS AS AN INPUT FILE, ALLOWS
'      INPUT AND OUTPUT TO BE IN EITHER METRIC OR ENGLISH UNITS AND
'      ALLOWS A NON-UNIFORM GAS INPUT VELOCITY AND TEMPERATURE
'      DISTRIBUTION.  THE WORKING FLUID IS EITHER FUEL-AIR OR HELIUM.
'
*****
*****INITIALIZATION SECTION*****
'
DECLARE FUNCTION TANH! (X!)
DECLARE FUNCTION YN% ()
DECLARE FUNCTION MIN! (X!, Y!)
DECLARE SUB SURF (T%, NS%, S$, AA!, BB!, SF!, PS!, RH!, DEL!, BET!, FR!, WF!, WP!)
DECLARE SUB STAT (TYPE$, nn%, A!())
DECLARE SUB TRANSP (T!, FAR!, CP!, TK!, M'', MW!, GTYPE%)
DECLARE SUB INTERP (A!(), RE!, NST!, F!)
DECLARE SUB BENDLOS (X!, Y!)

CONST PI = 3.14159, R = 1545!, GC = 32.2
CONST S = "-", TRUE = -1, FALSE = 0, YES = -1, NO = 0
COMMON SHARED /TRANSP1/ A1, A2, A3, A4, A5, A6, A7, A8, B1, B2, B3, B4, B5, B6, B7, B8
COMMON SHARED /TRANSP2/ C1, C2, C3, C4, C5, C6, C7, D1, D2, D3, D4, D5, D6, D7
COMMON SHARED /TRANSP3/ E1, E2, E3, E4, E5, E6, E7, F1, F2, F3, F4, F5, F6, F7

OPTION BASE 1
DEFINT I-K
DIM TA(2), TG(2), TW(2), TGRW(2), XNRA(2), XNRG(2)
DIM SURFACES(4), STATSS(4)
DIM STATA(18, 4), STATG(18, 4)
READ A1, A2, A3, A4, A5, A6, A7, A8
  DATA 1.0115540E-25, -1.4526770E-21, 7.6215767E-18, -1.5128259E-14
  DATA -6.7178376E-12, 6.5519486E-08, -5.1536879E-05, 2.5020051E-01
READ B1, B2, B3, B4, B5, B6, B7, B8
  DATA 7.2678710E-25, -1.3335668E-20, 1.0212913E-16, -4.2051104E-13
  DATA 9.9686793E-10, -1.3771901E-06, 1.2258630E-03, 7.3816638E-02
READ C1, C2, C3, C4, C5, C6, C7
  DATA -6.2176401E-22, 7.1827364E-18
  DATA -3.1410386E-14, 6.7214720E-11, -7.5336781E-8, 6.1979074E-5, -4.81E-3
READ D1, D2, D3, D4, D5, D6, D7
  DATA 1.0404582E-19, -7.5213293E-16

```

```

DATA 2.1637607E-12,-3.1593096E-9,2.4649233E-6,-9.0800204E-4,1.1073E-1
READ E1, E2, E3, E4, E5, E6, E7
DATA 2.4724974E-21,-1.6756272E-17
DATA 4.1505396E-14,-3.9906519E-11,-9.1347177E-9,8.8743855E-5,2.98E-3
READ F1, F2, F3, F4, F5, F6, F7
DATA -2.0255169E-19,1.4196996E-15
DATA -3.9713025E-12,5.6582466E-9,-4.3414613E-6,1.8135009E-3,-3.3929E-1

FOR I = 1 TO 4: READ SURFACE$(I), STATS$(I): NEXT I
DATA "PLAIN", "PLAIN.STA", "LOUVERED", "LOUVERED.STA"
DATA "STRIP", "STRIP.STA", "WAVY", "WAVY.STA"

DIM C(2, 8), C$(2, 8)
FOR I = 1 TO UBOUND(C, 2)
  FOR J = 1 TO 2
    READ C(J, I), C$(J, I)
NEXT J, I
DATA 1, "in", .3937, "cm"
DATA 1, "ft", 3.28084, "m "
DATA 1, "ft3", 10.76391, "m3"
DATA 1, "cu ft", 35.31467, "cu m "
DATA 1, "°R", 1.8, "°K"
DATA 1, "psia", 145.0377, "MPa "
DATA 1, "lb", 2.2046, "kg"
DATA 1, "Btu/hr-ft-°R", .578176051, "W/m-°K"

DIM FTYPE$(2)
READ FTYPE$(1), FTYPE$(2)
DATA "AIR-FUEL", "HELIUM"
READ RHO, KI, ERR LIM, FTYPA%, FTYPG%, UT%
DATA 489., 12., .001, 1, 1, 1
READ E, DELPA, DELPG, IRUN
DATA .5, 0.01, 0.03, 1
READ TYP A%, NSA%, TYPG%, NSG%, NV%, NH%
DATA 3,14, 3,15, 1, 1
READ RLENI, AFRA, FARG, FARA
DATA 0.9275, 0.643, .0145, 0.0
READ WA, PINA, TINA
DATA 90.0, 116.4, 1040.5
READ WG, PEXG, TING
DATA 101.45, 14.70, 1646.4
READ VINA, Tp
DATA 90.0, .012
DIM VING(NV%, NH%), MDOT(NV%, NH%), TIN(NV%, NH%)
SCREEN 0, 0, 0: WIDTH 80: CLS

PRINT " *****"
PRINT " WELCOME TO THE PERFORMANCE PREDICTION "
PRINT " PROGRAM FOR COMPACT PLATE-FIN HEAT EXCHANGERS"
PRINT " HEAT EXCHANGER TYPE TO BE SPECIFIED AS FOLLOWS- "
PRINT " WHERE TYPE: "
GOSUB FINTYPE:

```

```

PRINT " THE PROGRAM WILL ACCEPT AN INPUT FILE OR THE HOT AND"
PRINT " COLD SIDE PARAMETERS CAN BE ENTERED MANUALLY."
PRINT
PRINT " OTHER INPUT IS SELF-EXPLANATORY."
PRINT " THE PROGRAM IS BASED ON A COMPUTER MODEL FOUND IN"
PRINT " DTNSRDC PAS 82-41."
PRINT " FOR A LISTING OF HEAT EXCHANGER SURFACE PARAMETERS"
PRINT " RUN THE PROGRAM SURFLIST."
PRINT "*****"
PRINT

'*****INPUT SECTION *****
'
TOP:
PRINT
PRINT " DO YOU WANT TO USE AN INPUT FILE? ";
IF YN% = YES THEN
  PRINT "FILE NAME <"; DOC$; ">";
  INPUT F$
  IF F$ <> "" THEN DOC$ = F$
  ON ERROR GOTO FILEERR1
  OPEN DOC$ FOR INPUT AS #1
  PRINT "READING RUN # "; IRUN; " FROM FILE "; DOC$
  LINE INPUT #1, COMMENT$
  INPUT #1, UT%: ' type of units
  INPUT #1, TYPA%, NSA%, FTYPA%: ' cold side surface
  INPUT #1, TYPG%, NSG%, FTYPG%: ' hot side surface
  INPUT #1, RHO, K!, Tp: ' heat exchanger properties
  INPUT #1, AFRA, RLENI: ' frontal area and core length
  INPUT #1, WA, TINA, PINA, VINA: ' cold side conditions
  INPUT #1, WG, PEXG: ' hot side conditions
  INPUT #1, NH%, NV%: ' number of nodes
  XMAX = 0!
  ' ** load hot side velocity, temp, and mass flow arrays
  REDIM VING(NV%, NH%), TIN(NV%, NH%), MDOT(NV%, NH%)
  FOR J = 1 TO NV%
    FOR I = 1 TO NH%
      INPUT #1, VING(J, I), TIN(J, I)
      VING(J, I) = VING(J, I) * C(UT%, 2): ' CONVERT TO ENGLISH UNITS
      TIN(J, I) = TIN(J, I) * C(UT%, 5)
      MDOT(J, I) = VING(J, I) / TIN(J, I)
      XMAX = XMAX + MDOT(J, I)
    NEXT I, J
  TING = 0!
  FOR J = 1 TO NV%
    FOR I = 1 TO NH%
      MDOT(J, I) = MDOT(J, I) * WG / XMAX * C(UT%, 7)
      TING = TING + TIN(J, I) * MDOT(J, I) / C(UT%, 7)
    NEXT I, J

```

```

TING = TING / WG
INPUT #1, FARA, FARG: ' fuel air ratio on both sides
CLOSE 1
ELSE
  DOC$ = "NONE"
END IF
/ ***** INPUT FILE HAS BEEN READ - ALLOW MODIFICATION
/
DO
  PRINT
  PRINT "THE INPUT FILE HAS THE FOLLOWING LABEL"
  PRINT COMMENT$
  PRINT "IS THIS CORRECT? ";
  I = YN%
  IF I = NO THEN
    PRINT "ENTER THE NEW LABEL"
    LINE INPUT COMMENT$
  END IF
  LOOP WHILE I = NO
DO
  IF UT% = 1 THEN A$ = "ENGLISH" ELSE A$ = "METRIC"
  PRINT
  PRINT A$; " UNITS ARE BEING USED. IS THIS CORRECT? ";
  I = YN%
  IF I = NO THEN UT% = 2 \ UT%
  LOOP WHILE I = NO
CALL SURF(TYPA%, NSA%, "COLD", AXA, BXA, SFA, BA, RHA, DELA, BETA, FRA, WFA, WPA)
CALL SURF(TYPG%, NSG%, "HOT", AXG, BXG, SFG, BG, RHG, DELG, BETG, FRG, WFG, WPG)
DO: CLS
  PRINT "THE CURRENT HEAT EXCHANGER MATERIAL PROPERTIES ARE AS FOLLOWS:"
  PRINT
  PRINT "DENSITY ", , RHO; C$(UT%, 7); "/"; C$(UT%, 4)
  PRINT "THERMAL CONDUCTIVITY ", K!; C$(UT%, 8)
  PRINT "PLATE THICKNESS", Tp; C$(UT%, 1)
  PRINT : PRINT "IS THE ABOVE CORRECT? "; : I = YN%
  IF I = NO THEN
    PRINT
    PRINT "DENSITY ("; C$(UT%, 7); "/"; C$(UT%, 4); ")";
    INPUT RHO
    PRINT "THERMAL CONDUCTIVITY ("; C$(UT%, 8); ")"; : INPUT K!
    PRINT "PLATE THICKNESS ("; C$(UT%, 1); ")"; : INPUT Tp
  END IF
  LOOP WHILE I = NO
  RHO = RHO * C(UT%, 7) / C(UT%, 4)
  Tp = Tp * C(UT%, 1)
  K! = K! * C(UT%, 8)

```

```

DO: CLS
PRINT "THE HOT SIDE FLUID IS "; FTYPE$(FTYPG%)
PRINT "THE COOL SIDE FLUID IS "; FTYPE$(FTYPA%)
PRINT "IS THE ABOVE CORRECT? "; : I = YN%
IF I = NO THEN
PRINT
PRINT "THE CHOICES OF FLUID TYPE ARE:"
U% = UBOUND(FTYPE$)
FOR J = 1 TO U%: PRINT "      "; J, FTYPE$(J): NEXT J
PRINT : PRINT
DO
PRINT "THE HOT SIDE FLUID IS (1 -"; U%; ") "; : INPUT J
LOOP WHILE J < 1 OR J > U%
FTYPG% = J
DO
PRINT "THE COLD SIDE FLUID IS (1-"; U%; ") "; : INPUT J
LOOP WHILE J < 1 OR J > U%
FTYPA% = J
PRINT
END IF
LOOP WHILE I = NO

DO: CLS
PRINT
PRINT " THE CURRENT CORE SIZE IS AS FOLLOWS:"
PRINT "FRONTAL AREA - "; AFRA; " ("; C$(UT%, 3); ")"
PRINT "COUNTERFLOW LENGTH - "; RLENI; " ("; C$(UT%, 2); ")": PRINT
PRINT " IS THE ABOVE CORRECT? "; : I = YN%
IF I = NO THEN
PRINT : PRINT "WHAT IS THE FRONTAL AREA "; C$(UT%, 3);
INPUT AFRA
PRINT "WHAT IS THE COUNTERFLOW LENGTH "; C$(UT%, 2);
INPUT RLENI
END IF
LOOP WHILE I = NO
AFRA = AFRA * C(UT%, 3): ' *** CONVERT TO ENGLISH UNITS
RLENI = RLENI * C(UT%, 2)

DO: CLS
PRINT "THE CURRENT COLD SIDE CONDITIONS ARE AS FOLLOWS:": PRINT
PRINT "MASS FLOW RATE - "; WA; C$(UT%, 7); "/s"
PRINT "VELOCITY - "; VINA; C$(UT%, 2); "/s"
PRINT "INLET TEMP - "; TINA; C$(UT%, 5)
PRINT "INLET PRESSURE - "; PINA; C$(UT%, 6): PRINT
PRINT " IS THE ABOVE CORRECT? "; : I = YN%
IF I = NO THEN
PRINT : PRINT "ENTER THE COLD SIDE CONDITIONS."
PRINT "MASS FLOW RATE ("; C$(UT%, 7); "/s)": : INPUT WA
PRINT "VELOCITY ("; C$(UT%, 2); "/s)": : INPUT VINA
PRINT "INLET TEMPERATURE ("; C$(UT%, 5); ")": : INPUT TINA

```

```

      PRINT "INLET PRESSURE      ("; C$(UT%, 6); ")"; : INPUT PINA
    END IF
    LOOP WHILE I = NO
    WA = WA * C(UT%, 7)
    TINA = TINA * C(UT%, 5)
    VINA = VINA * C(UT%, 2)
    PINA = PINA * C(UT%, 6)

    DO: CLS
      PRINT "THE CURRENT HOT SIDE CONDITIONS ARE AS FOLLOWS:": PRINT
      PRINT "TOTAL MASS FLOW RATE - "; WG; C$(UT%, 7); "/s"
      PRINT "EXIT PRESSURE      - "; PEXG; C$(UT%, 6): PRINT
      PRINT " IS THE ABOVE CORRECT? "; : I = YN%
      IF I = NO THEN
        PRINT : PRINT "ENTER THE HOT SIDE CONDITIONS.": PRINT
        PRINT "MASS FLOW RATE ("; C$(UT%, 7); "/s)"; : INPUT WG
        PRINT "EXIT PRESSURE  ("; C$(UT%, 6); ")"; : INPUT PEXG
      END IF
    LOOP WHILE I = NO
    WG = WG * C(UT%, 7): '          ***CONVERT TO ENGLISH UNITS
    PEXG = PEXG * C(UT%, 6)
    XMAX = 0!

    CLS
    PRINT "THERE ARE "; NH%; " HORIZONTAL AND "; NV%; " VERTICAL NODES."
    PRINT : PRINT "IS THIS CORRECT? ";
    IF YN% = YES THEN
      CLS
      PRINT "THE CURRENT HOT SIDE VELOCITY AND TEMPERATURE PROFILE IS AS FOLLOWS:"
      PRINT "NODE", "VELOCITY", "TEMPERATURE"
      PRINT , C$(UT%, 2); "/sec", C$(UT%, 5)
      FOR J = 1 TO NV%
        FOR I = 1 TO NH%
          PRINT "("; J; ", "; I; ")", VING(J, I) / C(UT%, 2), TIN(J, I) / C(UT%, 5)
        NEXT I, J
      PRINT
      PRINT " WANT TO CHANGE ANY HOT SIDE VELOCITIES OR TEMPERATURES? ";
      IF YN% = YES THEN GOSUB GASVELPRO2
    ELSE
      GOSUB GASVELPRO:
    END IF
    PRINT
    IF FTYPG% = 1 OR FTYPA% = 1 THEN
      DO: CLS
      PRINT "THE CURRENT HOT SIDE FUEL-AIR RATIO IS "; FARG
      PRINT "THE CURRENT COLD SIDE FUEL-AIR RATIO IS "; FARA
      PRINT : PRINT "IS THE ABOVE CORRECT? "; : I = YN%
      IF I = NO THEN
        PRINT
        INPUT "HOT SIDE FUEL-AIR RATIO IS? "; FARG

```

```

      INPUT "COLD SIDE FUEL-AIR RATIO IS? "; FARA
      END IF
      LOOP WHILE I = NO
      ELSE
        FARG = 0!
        FARA = 0!
      END IF
      /
      ***** CALCULATION SECTION*****
      /***** HEAT EXCHANGER CORE DIMENSIONS *****/
      /
      CALL STAT((STATS$(TYP A%)), NSA%, STATA())
      CALL STAT((STATS$(TYP G%)), NSG%, STATG())
      /
      CALL TRANSP(TINA, 0!, CPA, KA!, MUA, MA, FTYP A%)
      RU = R / MA
      RHOINA = PINA / TINA / RU * 144!
      DINA = SQR(4! * WA / RHOINA / VINA / PI)
      /***** HEAT TRANSFER AND FREE FLOW AREAS *****/
      /
      /***** INITIAL LOOP VALUES*****
      VOL = AFRA * RLENI
      ALHA = BETA * BA / (BA + BG + 2! * Tp)
      ALHG = BETG * BG / (BA + BG + 2! * Tp)
      AA = ALHA * VOL
      AG = ALHG * VOL
      ANODE = AFRA / NV% / NH%
      SIGA = ALHA * RHA
      SIGG = ALHG * RHG
      ACA = SIGA * AFRA
      ACG = SIGG * AFRA
      GA = WA / ACA
      ACANODE = ACA / NV% / NH%
      ACGNODE = ACG / NV% / NH%
      WANODE = WA / NV% / NH%
      FLA = VOL / AFRA
      XNCFE = SQR(AFRA)
      CMIN = 1!
      CA = 1!
      CG = 1!
      DELPT = DELPA + DELPG
      EOLD = 0!
      DPT = 0!
      /
      ***** START OF PRESSURE LOOP *****
      DO
        TBULKEA = 0!
        TBULKEG = 0!
        DPT = DELPT
        PEXA = PINA * (1! - DELPA)

```

```

PING = PEXG * (1 + DELPG)
FOR J = 1 TO NV%
FOR I = 1 TO NH%

      ***** START OF E-NTU LOOP ***
DO

      ***** FIND EXIT TEMPERATURES FOR EACH NODE
TEXA = E * (TIN(J, I) - TINA) * CMIN / CA + TINA
TEXG = E * (TINA - TIN(J, I)) * CMIN / CG + TIN(J, I)
TAVG = (TEXG + TIN(J, I)) * .5
TAVA = (TEXA + TINA) * .5

      ***** AVERAGE CORE FLUID PROPERTIES
CALL TRANSP (TAVA, FARA, CPA, KA1, MUA, MA, FTYPA%)
CALL TRANSP (TAVG, FARG, CPG, KG1, MUG, MG, FTYPG%)

      ***** AVERAGE CORE REYNOLDS NUMBERS
GG = MDOT(J, I) / ACGNODE
NRA = 41 * RHA * GA / MUA
NRG = 41 * RHG * GG / MUG

      *****STANTON NUMBER, COLBURN FACTOR, AND FRICTION FACTOR
CALL INTERP (STATA(), NRA, COLBFA, FA)
IF FA = 0! GOTO ERR1:
NRA = CPA * MUA / KA1: '          prandel number
NSTA = COLBFA / NRA ^ .666: '    stanton number
HA = NSTA * GA * CPA * 3600!: '  heat trans coeff
CALL INTERP (STATG(), NRG, COLBFG, FG)
IF FG = 0! GOTO ERR1:
NPRG = CPG * MUG / KG1
NSTG = COLBFG / NPRG ^ .666
HG = NSTG * GG * CPG * 3600!

      ***** FIN EFFECTIVENESS
MAL = SQR((21 * HA) / (K1 * DELA / 121)) * (BA / 241)
MGL = SQR((21 * HG) / (K1 * DELG / 121)) * (BG / 241)
ETAFA = TANH1(MAL) / MAL
ETAFG = TANH1(MGL) / MGL

      ***** SURFACE EFFECTIVENESS
ETAOA = 11 - FRA * (11 - ETAFA)
ETAOG = 11 - FRG * (11 - ETAFG)

      ***** OVERALL COEFFICIENT OF HEAT TRANSFER
RA = 11 / (ETAOA * HA) + 11 / ((AG / AA) * ETAOG * HG) + 11 / (K1 / (Tp / 121))
UA = 11 / RA
EOLD = E

      ***** NTU AND HEAT EXCHANGER EFFECTIVENESS
CA = WANODE * CPA * 3600!
CG = MDOT(J, I) * CPG * 3600!
CMIN = MIN1(CA, CG)
CR = MIN1(CMIN / CA, CMIN / CG)
NTU = AA * UA / CMIN / NV% / NH%

```

```

      IF CR = 1 THEN
        E = NTU / (1 + NTU)
      ELSE
        X = EXP(-NTU * (1 - CR))
        E = (1 - X) / (1 - CR * X)
      END IF
      TEXA = E * (TIN(J, I) - TINA) * CMIN / CA + TINA
      TEXG = E * (TINA - TIN(J, I)) * CMIN / CG + TIN(J, I)
      check for convergence
      LOOP WHILE (ABS(EOLD / E - 1) > ERRLIM)
      ****BOTTOM OF E-NTU LOOP

      TBULKEG = TBULKEG + MDOT(J, I) * TEXG
      TBULKEA = TBULKEA + WANODE * TEXA
    NEXT I, J

    LOOP COMPLETE - GET BULK PROPERTIES FOR REST OF PROGRAM
    AND CALCULATE EFFECTIVENESS & NTU

    TEXG = TBULKEG / WG
    TEXA = TBULKEA / WA
    TAVA = (TEXA + TINA) * .5
    TAVG = (TEXG + TING) * .5
    CALL TRANSP(TAVA, FARA, CPA, KA!, MUA, MA, FTYPA%)
    CALL TRANSP(TAVG, FARG, CPG, KG!, MUG, MG, FTYPG%)
    GG = WG / ACG
    NRA = 4! * RHA * GA / MUA
    NRG = 4! * RHG * GG / MUG
    CALL INTERP(STATA(), NRA, COLBFA, FA)
    CALL INTERP(STATG(), NRG, COLBFG, FG)
    IF COLBFA = 0! OR COLBFG = 0! GOTO ERR1
    CA = WA * CPA * 3600!
    CG = WG * CPG * 3600!
    CMIN = MIN!(CA, CG)
    CR = MIN!(CMIN / CA, CMIN / CG)

    ***** EFFECTIVENESS AND NTU FOR WHOLE HX *****
    E = (CA / CMIN) * (TEXA - TINA) / (TING - TINA)
    IF CR = 1 THEN
      NTU = E / (1 - E)
    ELSE
      NTU = LOG((1 - E) / (1 - CR * E)) / (CR - 1)
    END IF

    ***** PRESSURE DROP FOR WHOLE HX CALCULATED HERE***
    ***** INLET AND EXIT LOSS COEFFICIENTS *****

    CCA/G JET CONTRACTION -AREA RATIO
    CCA = .61000000001# - .14442945071# * SIGA + 1.0080347435# * SIGA ^ 2
    CCA = CCA - 1.7317560083# * SIGA ^ 3 + 1.1559407939# * SIGA ^ 4
    CCG = .61000000001# - .14442945071# * SIGG + 1.0080347435# * SIGG ^ 2
    CCG = CCG - 1.7317560083# * SIGG ^ 3 + 1.1559407939# * SIGG ^ 4
    NARA = NRA * .0001

```

```

NARG = NRG * .0001
KDA! = 1.1063960104# - .13322445533# * NARA + .11885428625# * NARA ^ 2
KDA! = KDA! - .033170530592# * NARA ^ 3
KDG! = 1.1063960104# - .13322445533# * NARG + .11885428625# * NARG ^ 2
KDG! = KDG! - .033170530592# * NARG ^ 3
KCA! = (1! - 2! * CCA + CCA ^ 2 * (2! * KDA! - 1!)) / CCA ^ 2
KCG! = (1! - 2! * CCG + CCG ^ 2 * (2! * KDG! - 1!)) / CCG ^ 2
KEA! = 1! - 2! * KDA! * SIGA + SIGA ^ 2
KEG! = 1! - 2! * KDG! * SIGG + SIGG ^ 2

```

\*\*\*\*\* PRESSURE DROPS \*\*\*\*\*

```

RHOEXA = PEXA / TEXA / RU * 144!
RHOING = PING / TING / RU * 144!
RHOEXG = PEXG / TEXG / RU * 144!
VEXA = .636 * VINA * SQR(RHOINA / RHOEXA)
DEXA = SQR(4! * WA / RHOEXA / VEXA / PI)
HINA = RHOINA / 2! / GC * VINA ^ 2!
DELPAC = .595 * HINA / PINA / 144!
ILA! = 1! - SIGA ^ 2! + KCA!
ILG! = 1! - SIGG ^ 2! + KCG!
SPVA = PINA / PEXA * TEXA / TINA
SPVG = PING / PEXG * TEXG / TING
ELA = (1! - SIGA ^ 2! - KEA!) * SPVA
ELG = (1! - SIGG ^ 2! - KEG!) * SPVG
SPVAM = 2! * PINA / (PINA + PEXA) * TAVA / TINA
SPVGM = 2! * PING / (PING + PEXG) * TAVG / TING
CFA = FA * AA / ACA * SPVAM
CFG = FG * AG / ACG * SPVGM
FAA = 2! * (SPVA - 1!)
FAG = 2! * (SPVG - 1!)
TLA = ILA! + FAA + CFA - ELA
TLG = ILG! + FAG + CFG - ELG
LHGING = SQR(XNCFL ^ 2! - DEXA ^ 2!)
LHGEXG = SQR(XNCFL ^ 2! - DINA ^ 2!)
ANGEXG = ATN(DINA / LHGEXG)
ANGING = ATN(DEXA / LHGING)
ANGINA = PI / 2! - ANGEXG
ANGEXA = PI / 2! - ANGING
HFXG = 1! + ((DINA + DEXA) / 2! / FLA)
HFXA = (LHGING / 2! + FLA + LHGEXG / 2!) / FLA

***** CORE PRESSURE LOSS
DELPAC = (GA / 144! / PINA) ^ 2! / 2! / GC * 1545! / MA * TINA * TLA * HFXA
DELPAC = (GG / 144! / PING) ^ 2! / 2! / GC * 1545! / MG * TING * TLG * HFXG
AHCMINA = SIGA * DINA * XNCFL
AHCMING = SIGG * XNCFL * LHGING
VINAH1 = WA / RHOINA / AHCMINA
VINGH1 = WG / RHOING / AHCMING
VINAC1 = VINAH1 * COS(ANGINA)

```

```

VINGC1 = VINGH1 * COS(ANGING)
CALL BENDLOS(ANGINA, KBINA!)
CALL BENDLOS(ANGING, KBING!)
VINAM = SQR((VINAH1 ^ 2! + VINAC1 ^ 2!) / 2!)
VINGM = SQR((VINGH1 ^ 2! + VINGC1 ^ 2!) / 2!)
DELPAB1 = RHOINA * KBINA! / 2! / GC * VINAM ^ 2!
DELPGB1 = RHOING * KBING! / 2! / GC * VINGM ^ 2!
AHCMEXA = SIGA * DEXA * XNCFL
AHCMEYG = SIGG * LHGEXG * XNCFL
VEXAH2 = WA / RHOEXA / AHCMEXA
VEXGH2 = WG / RHOEXG / AHCMEYG
VEXAC2 = VEXAH2 * COS(ANGEXA)
VEXGC2 = VEXGH2 * COS(ANGEXG)
CALL BENDLOS(ANGEXA, KBEXA!)
CALL BENDLOS(ANGEXG, KBEXG!)
VEXAM = SQR((VEXAH2 ^ 2 + VEXAC2 ^ 2) / 2!)
VEXGM = SQR((VEXGH2 ^ 2 + VEXGC2 ^ 2) / 2!)
DELPAB2 = RHOEXA * KBEXA! / 2! / GC * VEXAM ^ 2!
DELPGB2 = RHOEXG * KBEXG! / 2! / GC * VEXGM ^ 2!
DELPAB = (DELPAB1 + DELPAB2) / PINA / 144!
DELPGB = (DELPGB1 + DELPGB2) / PING / 144!
DELPA = DELPAC + DELPAH + DELPAB
DELPG = DELPGC + DELPGB
PEXA = PINA * (1! - DELPA)
PING = PEXG * (1! + DELPG)
PCDELPA = 100! * DELPA
PCDELPG = 100! * DELPG
DELPT = DELPA + DELPG
PCDELPT = 100! * DELPT
PCNE = 100! * E
LOOP WHILE (ABS(DPT / DELPT - 1!) > ERLIM): ' CHECK FOR CONVERGENCE
/
/ ***** BOTTOM OF PRESSURE LOOP*****
/ ***** WEIGHT CALCULATIONS OF THE HEAT EXCHANGER *****
/
WTA = AA * RHO * (FRA * DELA * WFA + Tp * (1! - FRA) * WPA) / 24!
WTG = AG * RHO * (FRG * DELG * WFG + Tp * (1! - FRG) * WPG) / 24!
WPLA = 15! * (4! * XNCFL * FLA + PI * XNCFL * (DINA + DEXA) + LHGING * DEXA + LHGEXG *
DINA)
WIE = (WTA + WTG) / VOL * (LHGING * DEXA * XNCFL + LHGEXG * DINA * XNCFL) / 2!
WHXT = WTA + WTG + WPLA + WIE
OVALHT = DINA + DEXA + FLA
/ ***** WALL TEMPERATURE CALCULATIONS AT CORE EXIT *****
/
/ *** TEMPERATURES ARE CALCULATED USING BULK AVERAGE ENTRANCE ***
/
/ *** AND EXIT TEMPERATURES, NOT PEAK CHANNEL TEMPERATURES ***
/
TA(1) = TEXA
TA(2) = TINA

```

```

TG(1) = TING
TG(2) = TEXG
FOR J = 1 TO 2
  CALL TRANSP(TA(J), FARA, CPA, KA!, MUA, MA, FTYPA%)
  CALL TRANSP(TG(J), FARG, CPG, KG!, MUG, MG, FTYPG%)
  XNRA(J) = 4! * RHA * GA / MUA
  XNRG(J) = 4! * RHG * GG / MUG
  CALL INTERP(STATATA(), XNRA(J), COLBFA, FA)
  IF COLBFA = 0! GOTO ERRI
  NPRA = CPA * MUA / KA!
  NSTA = COLBFA / NPRA ^ .666
  HA = NSTA * GA * CPA * 3600!
  CALL INTERP(STATG(), XNRG(J), COLBFG, FG)
  IF COLBFG = 0! GOTO ERRI
  NPRG = CPG * MUG / KG!
  NSTG = COLBFG / NPRG ^ .666
  HG = NSTG * GG * CPG * 3600!
  MAL = SQR((2! * HA) / (K! * DELA / 12!)) * (BA / 24!)
  MGL = SQR((2! * HG) / (K! * DELG / 12!)) * (BG / 24!)
  ETAFA = TANH!(MAL) / MAL
  ETAFG = TANH!(MGL) / MGL
  ETAOA = 1! - FRA * (1! - ETAFA)
  ETAOG = 1! - FRG * (1! - ETAFG)
  RA = 1! / (ETAOA * HA) + 1! / (AG / AA * ETAOG * HG) + 1! / (K! / (Tp / 12!))
  UA = 1! / RA
  TW(J) = TG(J) - UA / (AG / AA * ETAOG * HG) * (TG(J) - TA(J))
  TGRW(J) = TG(J) - TW(J)

```

```

NEXT J

```

```

***** OUTPUT SECTION*****

```

```

XCDELPA = PINA * .01 * PCDELPA * 1728! / 62.4
XCDELPG = PING * .01 * PCDELPG * 1728! / 62.4
OPEN "SCRN:" FOR OUTPUT AS #1
CLS
I = 1: GOSUB OUTPRINT:
GOSUB HOLD
RUN$ = "OUTPUT." + RIGHT$(STR$(IRUN), LEN(STR$(IRUN)) - 1)
CLS : LOCATE 8, 1
GOSUB CHECKOUT
LOCATE 10, 1
PRINT "RESULTS FROM RUN NUMBER "; IRUN; " HAVE BEEN PLACED IN FILE "; RUN$
OPEN RUN$ FOR OUTPUT AS #2
I = 2: GOSUB OUTPRINT:
CLOSE 2
PRINT : PRINT "DO YOU WANT A HARDCOPY? ";
IF YN% = YES THEN
  PRINT "SET UP PRINTER."
  PRINT "PRESS <RETURN> WHEN READY."

```

```

      WHILE INKEY$ = "": WEND
      OPEN "LPT1:" FOR OUTPUT AS #3
      I = 3: GOSUB OUTPRINT:
      CLOSE 3
    END IF

ERR1:
  PRINT "DO YOU WANT TO SAVE THIS RUN AS AN INPUT FILE? ";
  IF YN% = YES THEN
    RUN$ = DOC$
    GOSUB CHECKOUT
    DOC$ = RUN$
    OPEN DOC$ FOR OUTPUT AS #2
    PRINT
    PRINT "SAVING RUN # "; IRUN; " AS INPUT FILE "; DOC$: PRINT
    PRINT #2, COMMENTS$
    WRITE #2, UT%: '                                type of units
    WRITE #2, TYPA%, NSA%, FTYPA%: '                cold side surface
    WRITE #2, TYPG%, NSG%, FTYPG%: '                hot side surface
    WRITE #2, RHO / C(UT%, 7) * C(UT%, 4), KI / C(UT%, 8), Tp / C(UT%, 1)
    WRITE #2, AFRA / C(UT%, 3), RLENI / C(UT%, 2)
    WRITE #2, WA / C(UT%, 7), TINA / C(UT%, 5), PINA / C(UT%, 6), VINA / C(UT%, 2)
    WRITE #2, WG / C(UT%, 7), PEXG / C(UT%, 6)
    WRITE #2, NH%, NV%
    FOR J = 1 TO NV%
      FOR I = 1 TO NH%
        WRITE #2, VING(J, I) / C(UT%, 2), TIN(J, I) / C(UT%, 5)
      NEXT I, J
    WRITE #2, FARA, FARG
    CLOSE 2
  END IF
  PRINT : PRINT "DO YOU WISH TO MAKE ANOTHER RUN? ";
  CLOSE
  IF YN% = YES THEN IRUN = IRUN + 1: GOTO TOP:
  END

GASVELPRO:
  '
  GAS VELOCITY PROFILE WILL BE ENTERED
  PRINT "HOT SIDE VELOCITY DISTRIBUTION "
  DO: INPUT "HOW MANY HORIZONTAL NODES? "; NH%: LOOP WHILE NH% < 1
  DO: INPUT "HOW MANY VERTICAL NODES? "; NV%: LOOP WHILE NV% < 1
  REDIM VING(NV%, NH%), TIN(NV%, NH%), MDOT(NV%, NH%)

GASVELPRO2:
  IF NH% + NV% > 2 THEN
    PRINT " IS THE HOT SIDE INLET TEMPERATURE THE SAME FOR ALL NODES? ";
    I1 = YN%
    IF I1 = YES THEN
      PRINT "ENTER THE HOT SIDE INLET TEMPERATURE ("; C$(UT%, 5); ") ";
      INPUT TING
      TING = TING * C(UT%, 5)
    
```

```

        PRINT "ENTER THE VELOCITY ("; C$(UT%, 2); "/sec) FOR EACH NODE."
        PRINT
    ELSE
        PRINT "ENTER THE VELOCITY ("; C$(UT%, 2); "/SEC) AND TEMPERATURE ("; C$(UT%, 5);
        ") "
        PRINT "FOR EACH NODE POINT SEPARATED BY COMMAS.": PRINT
    END IF
    FOR J = 1 TO NV%
    FOR I = 1 TO NH%
NODE:    PRINT "NODE ("; J; ", "; I; ") - ";
        IF I1 = YES THEN
            TIN(J, I) = TING
            INPUT VING(J, I)
            VING(J, I) = VING(J, I) * C(UT%, 2)
        ELSE
            INPUT VING(J, I), TIN(J, I)
            IF TIN(J, I) = 0! THEN BEEP: GOTO NODE
            VING(J, I) = VING(J, I) * C(UT%, 2)
            TIN(J, I) = TIN(J, I) * C(UT%, 5)
        END IF
        MDOT(J, I) = VING(J, I) / TIN(J, I)
        XMAX = XMAX + MDOT(J, I)
    NEXT I, J
'    NORMALIZE THE NODAL MASS FLOW RATES & FIND AVE INLET TEMP
        TING = 0!
        FOR J = 1 TO NV%
        FOR I = 1 TO NH%
            MDOT(J, I) = MDOT(J, I) * WG / XMAX
            TING = TING + TIN(J, I) * MDOT(J, I)
        NEXT I, J
        TING = TING / WG
    ELSE
        PRINT "ENTER THE HOT SIDE INLET TEMPERATURE ("; C$(UT%, 5); ") ";
        INPUT TING
        TING = TING * C(UT%, 5)
        PRINT "ENTER THE VELOCITY ("; C$(UT%, 2); "/sec) ";
        INPUT VING(1, 1)
        MDOT(1, 1) = WG
        PRINT
    END IF
    RETURN

/*****OUTPUT SUBROUTINE*****/
,
OUTPRINT:
    PRINT #I, "COMPACT HEAT EXCHANGER ANALYSIS": PRINT #I,
    PRINT #I, "RUN #"; IRUN; "      INPUT FILE "; DOC$
    PRINT #I, NH%; "x"; NV%; "NODES"
    PRINT #I, COMMENTS

```

```

PRINT #I,
PRINT #I, "CORE HEAT TRANSFER SURFACE";
PRINT #I, TAB(35); "COLD-SIDE"; TAB(50); "HOT-SIDE"
PRINT #I,
PRINT #I, "FIN TYPE"; TAB(35); SURFACES(TYPA*); TAB(50); SURFACES(TYPG*)
PRINT #I, "FIN AND SURFACE NUMBER"; TAB(35);
PRINT #I, USING "###" ; TYPA*; S; NSA*; TYPG*; S; NSQ*
PRINT #I, "Fina/"; C$(UT%, 1); TAB(35); SFA * C(UT%, 1);
    PRINT #I, TAB(50); SFG * C(UT%, 1)
IF AXA <> 0 OR AXG <> 0 THEN
PRINT #I, "FIN LENGTH ("; C$(UT%, 1); ")"; TAB(35); AXA * C(UT%, 1);
    PRINT #I, TAB(50); AXG * C(UT%, 1)
END IF
PRINT #I, "PLATE SPACING ("; C$(UT%, 1); ")"; TAB(35); BA / C(UT%, 1);
    PRINT #I, TAB(50); BG / C(UT%, 1)
PRINT #I, "HYDRAULIC RADIUS ("; C$(UT%, 1); ")"; TAB(35);
    PRINT #I, RHA * 12 / C(UT%, 1); TAB(50); RHG * 12 / C(UT%, 1)
PRINT #I, "FIN THICKNESS ("; C$(UT%, 1); ")"; TAB(35); DELA / C(UT%, 1);
    PRINT #I, TAB(50); DELG / C(UT%, 1)
PRINT #I, "COMPACTNESS ("; C$(UT%, 3); "/" ; C$(UT%, 4); ")"; TAB(35);
    PRINT #I, BETA * C(UT%, 2); TAB(50); BETG * C(UT%, 2)
PRINT #I, "FIN/TOTAL AREA ("; C$(UT%, 3); "/" ; C$(UT%, 3); ")"; TAB(35);
    PRINT #I, FRA; TAB(50); FRG
PRINT #I, "FLUID TYPE"; TAB(35); FTYPES(FTYPA*); TAB(50); FTYPES(FTYPG*)
PRINT #I,
PRINT #I, "LENGTH = "; TAB(19); RLENI / C(UT%, 2); C$(UT%, 2); TAB(39);
    PRINT #I, "VOLUME = "; TAB(48); VOL / C(UT%, 4); C$(UT%, 4)
PRINT #I, "FRONTAL AREA = "; TAB(19); AFRA / C(UT%, 3); C$(UT%, 3); TAB(39);
    PRINT #I, "HEIGHT = "; TAB(48); OVALHT / C(UT%, 2); C$(UT%, 2)
PRINT #I, "METAL DENSITY = "; TAB(19); RHO / C(UT%, 7) * C(UT%, 4); C$(UT%, 7); "/" ;
C$(UT%, 4);
    PRINT #I, TAB(39); "WEIGHT ="; TAB(48); WHXT / C(UT%, 7); C$(UT%, 7); "■"
PRINT #I, "PLATE THICKNESS ="; TAB(19); Tp / C(UT%, 1); C$(UT%, 1);
    PRINT #I, TAB(39); "K ="; TAB(48); KI / C(UT%, 8); C$(UT%, 8)
IF I = 1 THEN GOSUB HOLD ELSE PRINT #I, STRING$(70, "-")
PRINT #I, "COLD HEADER DESIGN DETAILS"
PRINT #I, TAB(35); "INLET"; TAB(61); "EXIT"
PRINT #I, "DIAMETER ("; C$(UT%, 2); ")"; TAB(29); DINA / C(UT%, 2);
    PRINT #I, TAB(48); DEXA / C(UT%, 2)
PRINT #I, "VELOCITY ("; C$(UT%, 2); "/sec"; TAB(29); VINA / C(UT%, 2);
    PRINT #I, TAB(48); VEXA / C(UT%, 2)
PRINT #I, STRING$(70, "-")
PRINT #I, "HEAT EXCHANGER CONDITIONS"
PRINT #I, TAB(35); "COLD-SIDE"; TAB(57); "HOT-SIDE"
PRINT #I, TAB(30); "INLET"; TAB(43); "EXIT"; TAB(53); "INLET"; TAB(65); "EXIT"
PRINT #I, "PRESSURE ("; C$(UT%, 6); ")"; TAB(28); PINA / C(UT%, 6); TAB(39);
    PRINT #I, PEXA / C(UT%, 6); TAB(50); PING / C(UT%, 6); TAB(61); PEXG / C(UT%, 6)
PRINT #I, "TEMPERATURE ("; C$(UT%, 5); ")"; TAB(28); TINA / C(UT%, 5); TAB(39);
    PRINT #I, TEXA / C(UT%, 5); TAB(50); TING / C(UT%, 5); TAB(61); TEXG / C(UT%, 5)

```

```

PRINT #I, "MASSFLOW ("; C$(UT%, 7); "/sec"; TAB(33); WA / C(UT%, 7);
  PRINT #I, TAB(55); WG / C(UT%, 7)
IF FTYP% = 1 OR FTYPG% = 1 THEN
  PRINT #I, "FUEL-AIR RATIO"; TAB(33); FARA; TAB(55); FARG
END IF
PRINT #I, "PRESSURE DROP (%)"; TAB(33); PCDELPA; TAB(55); PCDELPG
PRINT #I, "PRESSURE DROP (in H2O)"; TAB(33); XCDELPA; TAB(55); XCDELPG; PRINT #I,
PRINT #I, "HOT SIDE WALL TEMPERATURE ("; C$(UT%, 5); ")";
  PRINT #I, TAB(50); TW(1) / C(UT%, 5); TAB(61); TW(2) / C(UT%, 5)
PRINT #I, "REYNOLDS NUMBER"; TAB(50); XNRG(1); TAB(61); XNRG(2)
PRINT #I, "Tw-Tg ("; C$(UT%, 5); ")"; TAB(50);
  PRINT #I, TGRW(1) / C(UT%, 5); TAB(61); TGRW(2) / C(UT%, 5)
PRINT #I, STRING$(70, "-")
PRINT #I,
PRINT #I, "EFFECTIVENESS = "; TAB(19); PCNE; "%"; TAB(39);
  PRINT #I, "NTU = "; TAB(48); NTU; PRINT #I,
PRINT #I, "TOTAL PRESSURE DROP = "; PCDELPT; "%"
RETURN

FINTYPE:
PRINT
PRINT " TYPE 1 - PLAIN FIN           SURFACE NUMBER = 1 TO 18 "
PRINT " TYPE 2 - LOUVERED FIN        SURFACE NUMBER = 1 TO 14 "
PRINT " TYPE 3 - STRIP-OFFSET FIN      SURFACE NUMBER = 1 TO 18 "
PRINT " TYPE 4 - WAVY FIN              SURFACE NUMBER = 1 TO 3 "
PRINT
RETURN

HOLD:
'      ***** Suspends program execution until a key is pressed
LOCATE 25, 10
PRINT "PRESS ANY KEY TO CONTINUE";
DEF SEG = 0: POKE 1050, PEEK(1052): DEF SEG
DO: LOOP WHILE INKEY$ = ""
CLS
RETURN

CHECKOUT:
'      CHECKS FOR A BAD OUTPUT FILE OR WARNS OF OVERWRITE
PRINT "WHAT IS THE NAME OF THE FILE <"; RUN$; ">";
INPUT F$
IF F$ = "" THEN F$ = RUN$
EFLAG = FALSE
ON ERROR GOTO FILEERR2
OPEN F$ FOR INPUT AS #2
CLOSE 2
ON ERROR GOTO 0
IF NOT EFLAG THEN
  PRINT "WARNING - FILE "; F$; " EXISTS. OVERWRITE?";
  IF YN% = NO GOTO CHECKOUT

```

```

END IF
RUN$ = F$
RETURN

FILEERR1:
IF ERR = 53 THEN
  ' get another file name
  PRINT "File "; UCASE$(DOC$); " not found."
  INPUT "FILE NAME"; DOC$
  RESUME
ELSE
  ' some other error, so print message and abort
  PRINT "Unrecoverable error--"; ERR
  ON ERROR GOTO 0
END IF

FILEERR2:
'          BAD OUTPUT FILE TRAP
IF ERR = 64 THEN
  PRINT "BAD FILE NAME - RETYPE"
ELSEIF ERR = 53 THEN
  EFLAG = TRUE
  RESUME NEXT
ELSE
  BEEP
END IF
RESUME CHECKOUT:

BADSURFNUM:
'          ***** BAD SURFACE NUMBER TRAP
CLS
PRINT "BAD SURFACE OR TYPE NUMBER"
GOSUB FINTYPE:
EFLAG = TRUE
RESUME NEXT
END

SUB BENDLOS (X, Y) STATIC
'          ***** subroutine to calculate the pressure loss at a bend
Z = X * 57.29578
Y = 2.922713E-02 - 2.639695E-03 * Z + 2.272872E-04 * Z ^ 2 - 1.850293E-06 * Z ^ 3 +
3.655184E-08 * Z ^ 4 - 4.49784E-10 * Z ^ 5 + 2.088911E-12 * Z ^ 6
END SUB

SUB INTERP (A(), RE, COL, F) STATIC
J = 1
WHILE RE < A(J, 1): J = J + 1: WEND
I = J - 1
IF J = 1 THEN
  PRINT " REYNOLDS NUMBER OUT OF RANGE OF PROGRAMMED TABLES = "; RE
  COL = 0!

```

```

      F = 0!
      EXIT SUB
ELSE
  IF A(J, 1) = 0! THEN
    F = A(2, 4) / RE
    COL = A(1, 4) / RE ^ .7
  ELSE
    Z = (A(I, 1) - RE) / (A(I, 1) - A(J, 1))
    COL = Z * (A(J, 2) - A(I, 2))
    COL = A(I, 2) + COL
    F = Z * (A(J, 3) - A(I, 3))
    F = A(I, 3) + F
  END IF
END IF
END SUB

FUNCTION MIN! (X!, Y!) STATIC
  IF X! > Y! THEN MIN! = Y! ELSE MIN! = X!
END FUNCTION

SUB STAT (TYPE$, nn%, A()) STATIC
' *****
' SUBROUTINE STAT RETURNS STANTON NUMBERS AND FRICTION FLOW DATA
' FOR THE TYPE HEAT EXCHANGER SPECIFIED
' *****
OPEN TYPE$ FOR RANDOM AS #10 LEN = 16
FIELD #1., 16 AS Z$
'           read data from data base
I = (nn% - 1) * 18
FOR J = 1 TO 18
  GET #10, J + I
  FOR K = 1 TO 4
    A(J, K) = CVS(MID$(Z$, (K - 1) * 4 + 1, 4))
  NEXT K, J
CLOSE 10
END SUB

SUB SURF (T%, NS%, SIDE$, AA, BB, SF, PS, RE, DEL, BET, FR, WF, WP) STATIC
' ***** Subroutine to return heat exchanger surface properties from the
' data base files.
SHARED C(), C$(), SURFACE$(), UT%, EFLAG
DO: CLS
PRINT "THE CURRENT "; SIDE$; " SIDE HEAT EXCHANGER SURFACE IS AS FOLLOWS:"
ON ERROR GOTO BADSURFNUM:
EFLAG = FALSE
OPEN SURFACE$(T%) + ".DAT" FOR INPUT AS #10
IF T% < 1 OR NS% < 1 THEN EFLAG = TRUE
FOR J = 1 TO NS%
  INPUT #10, A, AA, BB, SF, PS, RH, DEL, B, BET, FR, WF, WP
  IF EFLAG THEN CLOSE 10: EXIT FOR

```

```

NEXT J
ON ERROR GOTO 0
IF EFLAG THEN
  I = NO: '      CATCHES A BAD SURFACE OR TYPE NUMBER
ELSE
  RH = RH / 4!
  CLOSE 10
  PRINT : PRINT , SURFACE$(T%); " FINS"
  PRINT
  PRINT , "FIN TYPE - "; T%
  PRINT , "SURFACE NUMBER - "; J - 1
  PRINT
  PRINT "PLATE SPACING", , PS / C(UT%, 1); C$(UT%, 1)
  PRINT "FIN THICKNESS", , DEL / C(UT%, 1); C$(UT%, 1)
  PRINT "FINS/"; C$(UT%, 1), , SF * C(UT%, 1)
  IF AA > 0 THEN PRINT "FIN LENGTH", , AA / C(UT%, 1); C$(UT%, 1)
  PRINT "HYDRAULIC RADIUS", RH * 12 / C(UT%, 1); C$(UT%, 1)
  PRINT "COMPACTNESS", , BET * C(UT%, 2); C$(UT%, 3); "/" ; C$(UT%, 4)
  PRINT "FIN/TOTAL AREA", FR; C$(UT%, 3); "/" ; C$(UT%, 3)
  PRINT
  PRINT "IS THE ABOVE CORRECT? "; : I = YN%
END IF

IF I = NO THEN
  PRINT : PRINT "ENTER THE "; SIDE$; " SIDE HEAT EXCHANGER SURFACE"
  PRINT
  INPUT "FIN TYPE"; T%
  INPUT "SURFACE NUMBER"; NS%
END IF

LOOP WHILE I = NO
END SUB

FUNCTION TANH! (X) STATIC
  TANH! = (EXP(X) - EXP(-X)) / (EXP(X) + EXP(-X))
END FUNCTION

SUB TRANSP (T, FAR, CP, TK, MU, MW, GTYPE%) STATIC
' ***** SUBROUTINE TO GET TRANSPORT PROPERTIES AT SPECIFIED TEMP
  SELECT CASE GTYPE%
  CASE 1: '      AIR-FUEL MIXTURE TRANSPORT PROPERTIES
'*****
  IF T < 500! OR T > 2000! GOTO OUTFRANGE:
  IF FAR < 0! OR FAR > .034826 GOTO OUTFRANGE:
  CP = ((((((A1 * T + A2) * T + A3) * T + A4) * T + A5) * T + A6) * T + A7) * T + A8
  IF FAR <> 0! THEN
    CPF = ((((((B1 * T + B2) * T + B3) * T + B4) * T + B5) * T + B6) * T + B7) * T + B8
    CP = (CP + FAR * CPF) / (1! + FAR)
  END IF
  TK = (((((C1 * T + C2) * T + C3) * T + C4) * T + C5) * T + C6) * T + C7
  IF FAR <> 0! THEN

```

```

      TKF = (((((D1 * T + D2) * T + D3) * T + D4) * T + D5) * T + D6) * T + D7
      TK = (TK + FAR * TKF) / (1 + FAR)
END IF
TK = TK / 3600!
MU = (((((E1 * T + E2) * T + E3) * T + E4) * T + E5) * T + E6) * T + E7
IF FAR <> 0! THEN
      MUF = (((((F1 * T + F2) * T + F3) * T + F4) * T + F5) * T + F6) * T + F7
      MU = (MU + FAR * MUF) / (1 + FAR)
END IF
MU = MU / 3600!
MW = 28.97 - .946186 * FAR

CASE 2: '                HELIUM TRANSPORT PROPERTIES
      /*****
      CP = 1.2404
      MU = .0006388 * T ^ .687 / 3600!
      TK = .001062 * T ^ .687 / 3600!
      MW = 4.002602

CASE ELSE
      PRINT "INCORRECT FLUID NUMBER", GTYPE%
      END
END SELECT
EXIT SUB

OUTOFRANGE:
      PRINT SPC(10); "TRANSP INPUT OUT OF RANGE:  TEMP = "; T; "      FAR = "; FAR
      STOP
END SUB

FUNCTION YN% STATIC
      ROW = CSRLIN: COL = POS(0)
      DO
      DEF SEG = 0: POKE 1050, PEEK(1052): DEF SEG : ' clear keyboard buffer
      X$ = "": ANS$ = ""
      DO: X$ = INKEY$: LOOP WHILE X$ = ""
      IF X$ = "Y" OR X$ = "y" THEN ANS$ = "Y": YN% = YES
      IF X$ = "N" OR X$ = "n" THEN ANS$ = "N": YN% = FALSE
      IF ANS$ = "Y" OR ANS$ = "N" THEN
      LOCATE 25, 10: PRINT SPC(50);
      LOCATE ROW, COL: PRINT ANS$
      ELSE
      BEEP
      LOCATE 25, 10: PRINT "PLEASE ANSWER YES OR NO"; : ANS$ = ""
      END IF
      LOOP UNTIL ANS$ = "Y" OR ANS$ = "N"
END FUNCTION

```

## B.2 Precooler Design Program PRECOOL.BAS.

PRECOOL.BAS uses the design method, as opposed to the analysis method used in COMPHX.BAS, to size the cross-flow precoolers. It uses many of the same steps as outlined above in COMPHX.BAS however in this case effectiveness and pressure drop are given and size is iterated until the calculated effectiveness and pressure drop match the desired values.

PRECOOL.BAS sizes the cross-flow heat exchangers used for the precoolers. It was taken, with very few modifications, directly from Appendix C in Reference 8. The program is line for line the same as Staudt's program except I substituted an alternate effectiveness equation (Equation B.1 instead of B.2) which allowed me to model lower water mass flow rates than were allowed in Staudt's program. I made water mass flow rate an input which allowed me to calculate the capacity ratio (Equation B.10) and NTU (Equation B.11) instead of inputting them. Finally, I included tabulated values for the fluid properties of water (viscosity, thermal conductivity, and Prandtl number) so the user does not have to perform the interpolation manually.\*

The equation used for NTU is:

$$C_r = \frac{C_{water}}{C_{helium}} \quad \text{B.13.}$$

$$NTU = -C_r \ln \left( 1 + \frac{1}{C_r} \ln(1 - \epsilon) \right) \quad \text{B.14.}$$

For a more detailed description of the program theory see chapter five of Reference 8. A sample of the output and the program listing follow.

---

\* Water properties are from Pitts & Sissom.

## B.2.1 Sample Output from PRECOOL.BAS

```
*****
PRECOOLER DESIGN PROGRAM
HELIUM TEMPS:  INLET = 167 °C           OUTLET = 30 °C
HELIUM INLET PRESSURE = 4.01 MPa
HELIUM MASS FLOW = 27.4 KG/SEC
WATER:  INLET TEMP = 20 °C  OUTLET TEMP = 38.61398 °C
        MASS FLOW = 250 KG/SEC  3970.525 GPM
HEAT EXCHANGER SURFACE:  S 1.50-125 (s)
RATIO OF HEAT CAPACITIES, (CW/Ch) = 7.360062

CROSSFLOW HEAT EXCHANGER
*****
-----RESULTS OF CALCULATIONS-----
CROSSFLOW HEAT EXCHANGER DIMENSIONS
VOL = 1.077307 m3
-----TUBESHEET-----
# OF TUBES = 11901           TUBE LENGTH = 1.193399 m
WIDTH = 1.1811 m           DEPTH = .7643056 m
-----GAS FLOW-----
PRESSURE DROP = 2.601114E-03           FRONTAL AREA = 1.409524 m2
GEOMETRY RATIO = .6437702
EFFECTIVENESS = .9319728           NTU = 3.344671
*****
```

## B.2.2 Source Code Listing for PRECOOL.BAS

```

DECLARE FUNCTION INTERP! (T!, A!())
  CONST PIE = 3.14159, E = 2.71828
  DIM WPR(5), WK(5)
  FOR I = 0 TO 5
    READ WPR(I), WK(I)
    WK(I) = WK(I) * 1.729577: ' convert to metric units
  NEXT I

' TABULATED DATA FOR WATER PRANDEL NUMBER AND THERMAL CONDUCTIVITY
'
'      Pr      k
DATA 13.6,    .319
DATA 7.02,    .345
DATA 4.34,    .363
DATA 3.02,    .376
DATA 2.22,    .386
DATA 1.74,    .393

PRINT "Precooler design program"

' *****HEAT EXCHANGER DATA IS PROVIDED IN THE DATA STATEMENT WHICH FOLLOW
' THE DATA NEEDED AN THE UNITS REQUIRED ARE LISTED BELOW
'
'   PARAMETER          UNITS          VARIABLE USED
' OUTSIDE DIAMETER      m              OD
' EFFECTIVE FIN LENGTH  m              DF
' FIN PITCH              FINS/m       FP
' HYDRAULIC DIAMETE    m              RH
' FIN THICKNESS         m              DEL
' FREE FLOW/FRONTAL AREA m^2/m^2      SIGMA
' FIN AREA/TOTAL AREA  m^2/m^2      AFA
' HEAT TRANSFER AREA/VOLUME m^2/m^3    ALFA
' LONGITUDINAL TUBE SPACING m          DT
' TRANSVERSE TUBE SPACING m          WT
' J1, J2, F1, F2
' SURFACE NAME          S$

  READ OD, LF, FP, RH, DEL, SIGMA, AFA, ALFA, DT, WT, J1, J2, F1, F2, S$

'
'   ****DATA FOR SURFACE CF-8.72
DATA .01067, .0056, 343, .004425, .00048, .494, .876, 446, .02032, .024765
DATA .222, .402, .29, .246, "CF-8.72
'
'   ****DATA FOR SURFACE S 1.50-1.00
DATA .009525, 0, 0, .006071, 0, .333, 0, 220.1, .009525, .014288
DATA .299, .399, .384, .221, "S 1.50-1.00"
'
'   ****DATA FOR SURFACE S 1.50-1.25 (#)
DATA .00635, 0, 0, .005029, 0, .333, 0, 263.5, .007938, .009525
DATA .3460, .4153, .2999, .1842, "S 1.50-125 (#)"
'
'   ****DATA FOR SURFACE 8.0 3/8T
DATA .01021, .007595, 314.96, .00363, .00033, .534, .913, 587., .0220, .0254
DATA .1735, .4069, .13568, .2218, "8.0 3/8 T"

RH = RH / 4

```

```

' HEAT EXCHANGER PROPERTIES
ID = .95 * OD
KM = 16
'           helium and water properties
CPW = 4189
PRH = .668
CPH = 5193
R = 2077

' DATA INPUT
INPUT "HELIUM MASS FLOW RATE (KG/SEC)"; MH
INPUT "HELIUM INLET PRESSURE (MPa)"; P6
P6 = P6 * 10 ^ 6
INPUT "HELIUM INLET TEMPERATURE (C)"; T6
T6 = T6 + 273.15
INPUT "HELIUM OUTLET TEMPERATURE TO COMPRESSOR"; T1
T1 = T1 + 273.15
Q = MH * CPH * (T6 - T1)
INPUT "HELIUM SPECIFIC PRESSURE DROP"; DP

TOP:
INPUT "INLET WATER VELOCITY (m/sec)"; VW
GW = VW * 980
INPUT "INLET WATER TEMPERATURE (C)"; TWI
TWJ = TWI + 273.15
EFF = (T6 - T1) / (T6 - TWI)
PRINT "WHAT IS THE DESIRED WATER FLOW RATE (KG/SEC)";
INPUT MW
CWCH = MW * CPW / MH / CPH
TWO = ((T6 - T1) / CWCH) + TWI
PRINT "EFFECTIVENESS = "; EFF
NTU = -CWCH * LOG(1 + LOG(1 - EFF) / CWCH)
PRINT "NTU ="; NTU
UA = NTU * MH * CPH
TAVG = .5 * (TWO + TWI) - 273.15
PRINT "AVERAGE WATER TEMPERATURE IS"; (.5 * (TWO + TWI)) - 273.15
GOSUB VISCWATER: '           FIND VISCOSITY OF WATER
PRW = INTERP(TAVG, WPR()): '           FIND PRANDTL NUMBER
IF PRW = 0 THEN INPUT "PRANDTL NO."; PRW
KW = INTERP(TAVG, WK())
IF KW = 0 THEN INPUT "THERMAL CONDUCTIVITY (W/mK)"; KW
PRINT VISH, PRW, KW
TAV = .5 * (T1 + T6)
DENS = P6 / R / TAV
VISH = (6.7 + .044 * TAV) * .000001
GH = ((.006 * P6 * DP * DENS) / (.02 * NTU * .7631)) ^ .5

' START LOOP
DO
  REH = (GH * 4 * RH) / VISH
  FH = F1 * REH ^ (-F2)

```

```

JH = J1 * REH ^ (-J2)
HH = (JH * GH * CPH) / (PRH ^ (2 / 3))
PRINT "H he = "; HH; "W/m2K", "G he ="; GH; "KG/m2S"
PRINT "Re he = "; REH, "JH = "; JH
HW = (.023 * KW * (PRW ^ .4) * GW ^ .8) / ((VISW ^ .8) * (ID ^ .2))
PRINT "HW = "; HW
IF LE <> 0 THEN
  M = SQR((2 * HH) / (KM * DEL))
  ML = M * LF
  NF = ((EXP(ML) - EXP(-ML)) / (EXP(ML) + EXP(-ML))) / ML
  NOF = 1 - AFA * (1 - NF)
ELSE
  NF = 0
  NOF = 1
END IF
A = (OD - ID) * .5
AWA = 1 - AFA
U = 1 / ((1 / HH / NOF) + (A / KM / AWA) + (1 / HW / AWA))
PRINT "FIN EFF. ="; NF, "U ="; U
AH = UA / U
PRINT "Q ="; Q
VOL = AH / ALFA
AC = MH / GH
AFR = AC / SIGMA
L = VOL / AFR
DELP = FH * AH * GH * GH / 2 / P6 / AC / DENSH
GH = GH * ((DP / DELP) ^ .5)
LOOP UNTIL ABS((DELP - DP) / DP) < .05
  END OF LOOP

NT = INT(4 * MW / (GW * PIE * ID * ID) + .5)
PRINT "OUTPUT TO SCREEN (1) OR PRINTER (2)";
INPUT I%
IF I% = 2 THEN U$ = "LPT1:" ELSE U$ = "SCRN:"
OPEN U$ FOR OUTPUT AS #1
PRINT #1, STRING$(40, "**")
PRINT #1, "PRECOOLER DESIGN PROGRAM"
PRINT #1,
PRINT #1, "HELIUM TEMPS: INLET ="; T6 - 273.15; "'C", "OUTLET ="; T1 - 273.15; "'C"
PRINT #1, "HELIUM INLET PRESSURE ="; P6 * .000001; "MPa"
PRINT #1, "HELIUM MASS FLOW ="; MH; "KG/SEC"
PRINT #1, "WATER: INLET TEMP ="; TWI - 273.15; "'C", "OUTLET TEMP ="; TWO - 273.15; "'C"
PRINT #1, "      MASS FLOW ="; MW; "KG/SEC "; MW * 15.8821; "GPM"
PRINT #1, "HEAT EXCHANGER SURFACE: "; S$
PRINT #1, "RATIO OF HEAT CAPACITIES, (CW/Ch) ="; CWCH
PRINT #1,
PRINT #1, "CROSSFLOW HEAT EXCHANGER"
PRINT #1, STRING$(40, "**")
PRINT #1, "-----RESULTS OF CALCULATIONS-----"
ND = INT(L / DT + .5)

```

```

NW = INT(NT / ND + .5)
W = NW * WT
LT = AFR / W
PRINT #1, "CROSSFLOW HEAT EXCHANGER DIMENSIONS"
PRINT #1, "VOL ="; VOL; "m3"
PRINT #1, "-----TUBESHEET-----"
PRINT #1, "‡ OF TUBES ="; NT, "TUBE LENGTH ="; LT; "m"
PRINT #1, "WIDTH ="; W; "m", "DEPTH ="; L; "m"
PRINT #1, "-----GAS FLOW-----"
PRINT #1, "PRESSURE DROP ="; DELP, "FRONTAL AREA ="; AFR; "m²"
PRINT #1, "GEOMETRY RATIO = "; L / SQR(AFR)
PRINT #1, "EFFECTIVENESS ="; EFF, "NTU ="; NTU
PRINT #1, STRING$(40, "**")
CLOSE

PRINT "DO YOU WANT TO TRY AGAIN WITH THE SAME EXCHANGER AND HELIUM CONDITIONS"
INPUT N$
IF ASC(N$) = 121 OR ASC(N$) = 89 GOTO TOP
CLOSE
END

VISCWATER:
/
***** FINDING THE VISCOSITY OF WATER
IF TWAvg <= 100 OR TWAvg > 0 THEN
  IF TWAvg <= 20 THEN
    VISW = .001 * 10 ^ (1301 / (998.333 + 8.1855 * (TWAvg - 20) + .00585 * (TWAvg - 20)
^ 2) - 1.30233)
  ELSEIF TWAvg <= 100 THEN
    VISW = .001 * 10 ^ ((1.3272 * (20 - TWAvg) - .001053 * (TWAvg - 20) ^ 2) / (TWAvg +
105)) * 1.002
  END IF
ELSE
  PRINT "WATER VISCOSITY (PaS * 10^-5)";
  INPUT VISW
  VISW = VISW * .00001
END IF
RETURN
END

FUNCTION INTERP (T, A()) STATIC
IF T < 0 OR T > 100 THEN INTERP = 0
IF T = 100 THEN INTERP = A(5): EXIT FUNCTION
IF T = 0 THEN INTERP = A(0): EXIT FUNCTION
U = T / 20
A% = INT(U)
INTERP = (U - A%) * (A(A% + 1) - A(A%)) + A(A%)
END FUNCTION

```

## Appendix C Heat Exchanger Surfaces Characteristics.

The following table gives the characteristics of the heat exchanger surfaces in the surface data base for COMPHX.BAS.

Table C-1. Heat Exchanger Surfaces. [11]

FIN TYPE	PLATE SPACING in	FIN THICKNESS in	FINS/in	FIN LENGTH in	HYD. RADIUS in	BETA ft <sup>2</sup> /cu ft	AREA RATIO ft <sup>2</sup> /ft <sup>2</sup>
<b>PLAIN FINS</b>							
1- 1	0.500	.00600	16.00	0.000	.02535	423	.897
1- 2	0.750	.03200	3.01	0.000	.10638	98	.706
1- 3	0.750	.03200	3.97	0.000	.08460	119	.766
1- 4	0.470	.00600	5.30	0.000	.06048	188	.719
1- 5	0.405	.01000	6.20	0.000	.05460	204	.728
1- 6	0.823	.00800	9.03	0.000	.04566	244	.888
1- 7	0.250	.00600	11.10	0.000	.03036	367	.756
1- 8	0.440	.00800	11.11	0.000	.03459	312	.854
1- 9	0.330	.00600	14.77	0.000	.02544	420	.844
1-10	0.418	.00600	15.08	0.000	.02628	414	.870
1-11	0.250	.00600	19.86	0.000	.01845	561	.849
1-12	0.544	.01000	10.27	0.000	.03777	290	.863
1-13	0.249	.00600	11.94	0.000	.02820	393	.769
1-14	0.250	.00600	12.00	0.000	.02823	393	.773
1-15	0.256	.00600	16.96	0.000	.01695	608	.861
1-16	0.204	.00600	25.79	0.000	.01131	856	.884
1-17	0.345	.00600	30.33	0.000	.01203	813	.928
1-18	0.100	.00200	46.45	0.000	.00792	1333	.837
<b>LOUVERED FINS</b>							
2- 1	0.250	.00600	6.06	0.375	.04380	256	.640
2- 2	0.250	.00600	6.06	0.375	.04380	256	.640
2- 3	0.250	.00600	6.06	0.500	.04280	256	.640
2- 4	0.250	.00600	6.06	0.500	.04380	256	.640
2- 5	0.250	.00600	8.70	0.375	.03588	307	.705
2- 6	0.250	.00600	8.70	0.375	.03588	307	.705
2- 7	0.250	.00600	11.10	0.188	.03036	367	.756
2- 8	0.250	.00600	11.10	0.250	.03036	367	.756
2- 9	0.250	.00600	11.10	0.250	.03036	367	.756
2-10	0.250	.00600	11.10	0.375	.03036	367	.756
2-11	0.250	.00600	11.10	0.375	.03036	367	.756
2-12	0.250	.00600	11.10	0.500	.03036	367	.756
2-13	0.250	.00600	11.10	0.750	.03036	367	.756
2-14	0.250	.00600	11.10	0.750	.03036	367	.756

## STRIP FINS

3- 1	0.250	.00600	11.10	0.250	.03036	367	.756
3- 2	0.485	.00400	12.22	0.094	.03360	340	.862
3- 3	0.414	.00600	15.20	0.125	.02604	417	.873
3- 4	0.375	.01000	13.95	0.125	.02637	381	.840
3- 5	0.237	.00600	11.94	0.500	.02232	461	.796
3- 6	0.206	.00600	15.40	0.250	.01581	642	.816
3- 7	0.353	.00400	12.18	0.167	.02655	422	.847
3- 8	0.304	.00400	15.75	0.143	.02037	526	.859
3- 9	0.201	.00400	20.06	0.125	.01467	698	.843
3-10	0.205	.00400	19.82	0.125	.01515	680	.841
3-11	0.206	.00600	16.12	0.125	.01527	660	.823
3-12	0.255	.00600	16.00	0.125	.01833	550	.845
3-13	0.314	.00600	16.12	0.125	.01542	650	.882
3-14	0.147	.01600	5.00	0.143	.03825	257	.416
3-15	0.550	.01600	6.50	0.500	.05478	191	.795
3-16	0.100	.00600	16.00	0.125	.01764	578	.625
3-17	0.075	.00400	24.12	0.111	.01191	853	.857
3-18	0.051	.00200	19.74	0.100	.01200	923	.923

## WAVY FINS

4- 1	0.413	.00600	11.48	0.375	.03180	351	.847
4- 2	0.375	.01000	11.50	0.375	.02979	347	.822
4- 3	0.413	.00600	17.80	0.375	.02088	514	.892

## Appendix D Heat Exchanger Surface Performance Data.

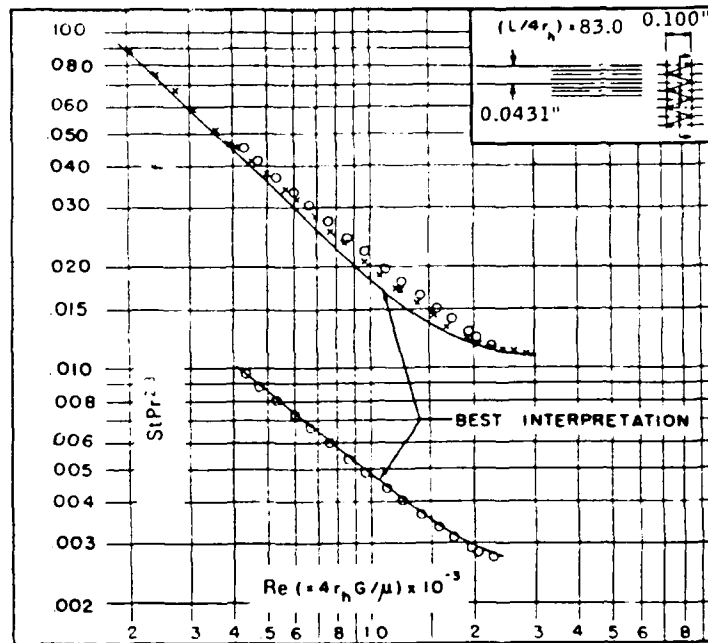

Fin pitch = 46.45 per in = 1829 per m

Plate spacing,  $b = 0.100$  in =  $2.54 \times 10^{-3}$  m

Fin length flow direction = 2.63 in =  $66.8 \times 10^{-3}$  m

Flow passage hydraulic diameter,  $4r_n = 0.002643$  ft =  $0.805 \times 10^{-3}$  m

Fin metal thickness = 0.002 in, stainless steel =  $0.051 \times 10^{-3}$  m

Total heat transfer area/volume between plates,  $\beta = 1332.45$  ft<sup>2</sup>/ft<sup>3</sup> =  $4372$  m<sup>2</sup>/m<sup>3</sup>

Fin area/total area = 0.837

Figure D-1. Plain-Fin plate-fin surface 46.45T.

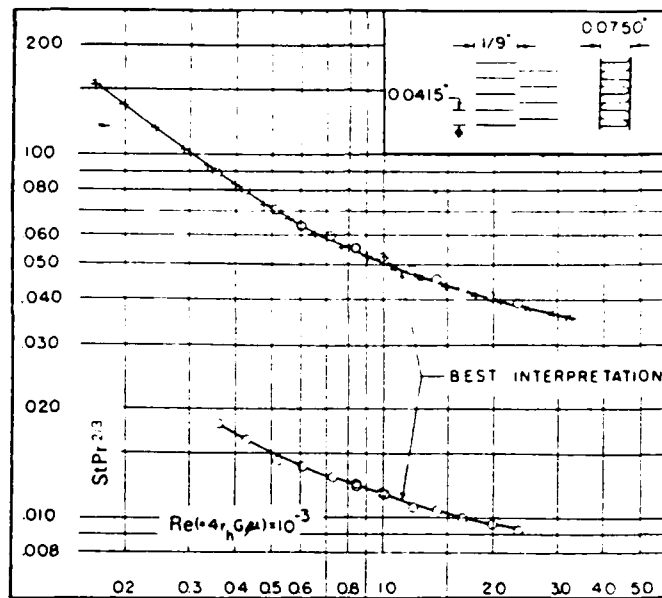

Fin pitch = 24.12 per in = 950 per m  
 Plate spacing,  $b = 0.075$  in =  $1.91 \times 10^{-3}$  m  
 Fin length = 0.111 in =  $2.8 \times 10^{-3}$  m  
 Flow passage hydraulic diameter,  $4r_h = 0.003966$  ft =  $1.209 \times 10^{-3}$  m  
 Fin metal thickness = 0.004 in =  $0.102 \times 10^{-3}$  m  
 Total heat transfer area/volume between plates,  $\beta = 862.7$  ft<sup>2</sup>/ft<sup>3</sup> =  $2,830$  m<sup>2</sup>/m<sup>3</sup>  
 Fin area/total area = 0.857

Figure D-2. Strip-fin plate-fin surface 1/9-24.12

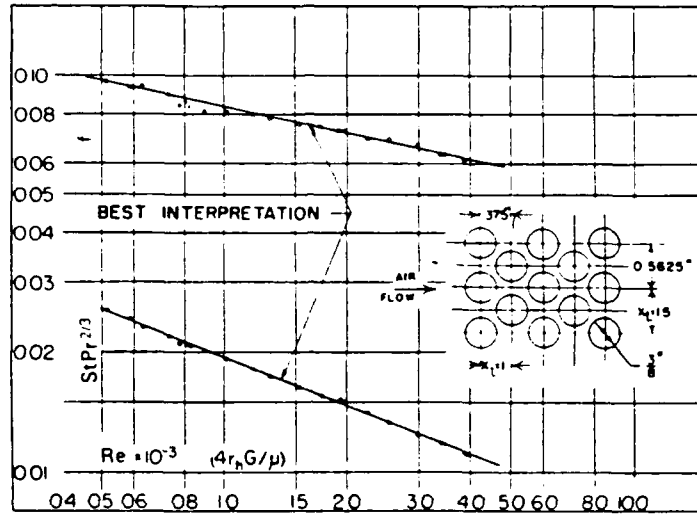

Tube outside diameter = 0.375 in =  $9.525 \times 10^{-3}$  m  
 Hydraulic diameter,  $4r_h$  = 0.0196 ft =  $6.071 \times 10^{-3}$  m  
 Free-flow area/frontal area,  $\sigma$  = 0.333  
 Heat transfer area/total volume,  $\alpha$  = 67.1 ft<sup>2</sup>/ft<sup>3</sup> = 220.144 m<sup>2</sup>/m<sup>3</sup>  
 Note: Minimum free-flow area is in spaces transverse to flow.

Figure D-3. Flow normal to a staggered tube bank, surface S 1.50-1.00

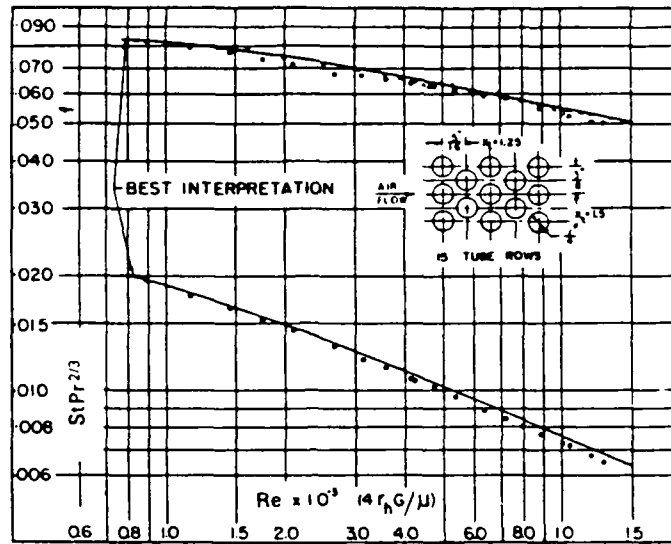

Tube outside diameter = 0.250 in =  $6.35 \times 10^{-3}$  m

Hydraulic diameter,  $4r_h = 0.0166$  ft =  $5.029 \times 10^{-3}$  m

Free-flow area/frontal area,  $\sigma = 0.333$

Heat transfer area/total volume,  $\alpha = 80.3$  ft<sup>2</sup>/ft<sup>3</sup> =  $263.451$  m<sup>2</sup>/m<sup>3</sup>

Note: Minimum free-flow area is in spaces transverse to flow.

Figure D-4. Flow normal to a staggered tube bank, surface S 1.50-1.25 (s)



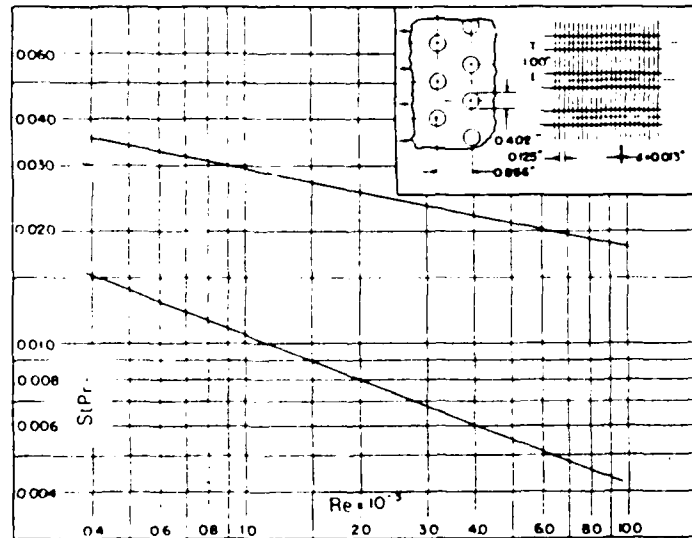

Tube outside diameter = 0.402 in =  $10.2 \times 10^{-3}$  m

Fin pitch = 8.0 per in = 315 per m

Flow passage hydraulic diameter,  $4r_h = 0.01192$  ft =  $3.632 \times 10^{-3}$  m

Fin thickness = 0.013 in =  $0.33 \times 10^{-3}$  m

Free flow area/frontal area,  $\sigma = 0.534$

Heat transfer area/total volume,  $\alpha = 179$  ft<sup>2</sup>/ft<sup>3</sup> =  $587$  m<sup>2</sup>/m<sup>3</sup>

Fin area/total area = 0.913

Note: Minimum free flow area in spaces transverse to flow.

Figure D-6. Surface 8.0-3/8T, Finned circular tubes, continuous fins.