

2

AD-A213 489

EVALUATION OF
IMO PRELIMINARY DRAFT RECOMMENDATION
ON FIRE TEST PROCEDURES FOR
UPHOLSTERED FURNITURE
(FP 32/WP.9 ANNEX 6)

WILLIAM H. McLAIN

U.S. COAST GUARD
Marine Safety Laboratories
Marine Fire and Safety Research Division
Avery Point, Groton, CT 06340 - 6096

EXHIBIT A

Final Report
December 1988

Document is available to the U.S. public through
The National Technical Information Service,
Springfield, Virginia 22161

DTIC
ELECTE
OCT 03 1989
S
E
D

Prepared for:

United States Coast Guard
Office of Marine Safety, Security,
and Environmental Protection
Washington, DC 20593

89 10 3 253

NOTICE

This document is disseminated under the sponsorship of the Department of Transportation in the interest of information exchange. The United States Government assumes no liability for its contents or use thereof.

This report does not constitute a standard, specification or regulation.

The United States Government does not endorse products or manufacturers. Trade or manufacturers' names appear herein solely because they are considered essential to the object of this report.

Technical Report Documentation Page

1. Report No. CG-M-5-89		2. Government Accession No.		3. Recipient's Catalog No.	
4. Title and Subtitle Evaluation of IMO Preliminary Draft Recommendation on Fire Test Procedures for Upholstered Furniture (FP 32/WP.9 Annex 6)				5. Report Date December 1988	
				6. Performing Organization Code 3308.56	
7. Author(s) William H. McLain				8. Performing Organization Report No. CG-MFSRD-69	
9. Performing Organization Name and Address Marine Safety Laboratories Marine Fire and Safety Research Division United States Coast Guard Avery Point, Groton, CT 06340-6096				10. Work Unit No. (TR AIS)	
				11. Contract or Grant No.	
12. Sponsoring Agency Name and Address Marine Technical and Hazardous Materials Division U.S. Coast Guard Department of Transportation Washington, D.C. 20593				13. Type of Report and Period Covered FINAL	
				14. Sponsoring Agency Code	
15. Supplementary Notes					
16. Abstract An evaluation was made of the fire test procedure outlined in "IMO Preliminary Draft Recommendation of Fire Test Procedures for Upholstered Furniture (FP 32/WP.9, Annex 6). This procedure prescribes methods for testing materials used in upholstered furnishings. The objective of this project was to determine how U.S. manufactured upholstery used by the marine industry will be affected by the proposed standard. Tests were conducted on six fabric materials currently used by the U.S. marine industry. All six materials passed the cigarette ignition test; five passed the simulated butane match test. Based on these results, it was concluded that the proposed IMO test would have a minimal impact on the U.S. manufactured seating materials used in the maritime industries.					
17. Key Words - ignition cigarette IMO fire test furniture				18. Distribution Statement This document is available to the U.S. public through the National Technical Information Service, Springfield, Virginia 22161	
19. Security Classif. (of this report) UNCLASSIFIED		20. SECURITY CLASSIF. (of this page) UNCLASSIFIED		21. No. of Pages	22. Price

Conversions to Metric Measures

When you know (symbol) Multiply by To find (symbol)

Length			
inches (in)	2.540	centimeters (cm)	
feet (ft)	30.48	centimeters (cm)	
feet (ft)	0.3048	meters (m)	
Area			
square inches (in ²)	6.452	square centimeters (cm ²)	
square feet (ft ²)	929.0	square centimeters (cm ²)	
square feet (ft ²)	0.09290	square meters (m ²)	
Volume			
fluid ounces, US (fl oz)	29.57	milliliters (ml); cubic centimeters (cm ³)	
gallons, US liquid (gal)	3.785	liters (l)	
cubic feet (ft ³)	0.02832	cubic meters (m ³)	
cubic yards (yd ³)	0.7646	cubic meters (m ³)	
Mass (weight)			
ounces, avoirdupois (oz)	28.35	grams (g)	
pounds (lb)	0.4536	kilograms (kg)	
Density			
pounds per cubic inch (lb/in ³)	27.68	grams per cubic centimeter (g/cm ³)	
pounds per cubic foot (lb/ft ³)	16.02	kilograms per cubic meter (kg/m ³)	
Pressure			
pounds per square inch (psi)	6895	pascals (Pa);	
pounds per square inch (psi)	0.0703	newtons per square meter (N/m ²)	
pounds per square inch (psi)	51.71	kilograms per square centimeter (kg/cm ²)	
pounds per square inch (psi)	0.06895	millimeters of mercury (mm Hg) at 0°C	
ches of water (in H ₂ O) at 60°F	1.867	bars (10 ⁵ N/m ²)	
ches of water (in H ₂ O) at 60°F	2.48.9	millimeters of mercury (mm Hg) at 0°C	
ches of water (in H ₂ O) at 60°F	0.002489	pascals (Pa)	
ches of mercury (in Hg) at 32°F	3386	bars (10 ⁵ N/m ²)	
ches of mercury (in Hg) at 32°F	0.03386	bars (10 ⁵ N/m ²)	
Energy			
British thermal units (Btu)	1055	joules (J); newton-meter (Nm)	
British thermal units (Btu)	0.2520	kilocalories (kcal)	
Thermal Conductance			
Btu / hr - ft ² - °F	0.0001356	calories / sec - cm ² - °C	
Btu / hr - ft ² - °F	0.4862	calories / hr - cm ² - °C	
Btu / hr - ft ² - °F	0.0005678	watts / cm ² - °C	
Heat Flow			
Btu / hr - ft ²	0.0007535	calories / sec - cm ²	
Btu / hr - ft ²	0.2712	calories / hr - cm ²	
Btu / hr - ft ²	0.0003154	watts / cm ²	

Fahrenheit Temperature

Conversions from Metric Measures

When you know (symbol) Multiply by To find (symbol)

Length			
millimeters (mm)	0.03937	inches (in)	
centimeters (cm)	0.3937	inches (in)	
meters (m)	39.37	inches (in)	
Meters (m)	3.281	feet (ft)	
Area			
square centimeters (cm ²)	0.1550	square inches (in ²)	
square centimeters (cm ²)	0.001076	square feet (ft ²)	
square meters (m ²)	1550	square inches (in ²)	
square meters (m ²)	10.76	square feet (ft ²)	
square meters (m ²)	1.196	square yards (yd ²)	
Volume			
milliliters (ml)	0.03381	fluid ounces, US (fl oz)	
liters (l)	0.2642	gallons, US liquid (gal)	
liters (l)	0.03531	cubic feet (ft ³)	
cubic centimeters (cm ³)	0.06102	cubic inches (in ³)	
cubic meters (m ³)	35.31	cubic feet (ft ³)	
cubic meters (m ³)	1.308	cubic yards (yd ³)	
Mass (weight)			
grams (g)	0.03527	ounces, avoirdupois (oz)	
grams (g)	0.002205	pounds (lb)	
kilograms (kg)	2.205	pounds (lb)	
Density			
grams per cubic centimeter (g/cm ³)	0.03613	pounds per cubic inch (lb/in ³)	
kilograms per cubic meter (kg/m ³)	0.06243	pounds per cubic foot (lb/ft ³)	
Pressure			
pascals (Pa);			
newtons per sq. meter (N/m ²)	0.000145	pounds per square inch (psi)	
bars (10 ⁵ N/m ²)	14.50	pounds per square inch (psi)	
kilograms per square centimeter (kg/cm ²)	14.22	pounds per square inch (psi)	
millimeters of mercury (mm Hg) at 0°C	0.01934	pounds per square inch (psi)	
millimeters of mercury (mm Hg) at 0°C	0.5357	inches of water (in H ₂ O) at 60°F	
bars (10 ⁵ N/m ²)	401.8	inches of water (in H ₂ O) at 60°F	
pascals (Pa)	0.00402	inches of water (in H ₂ O) at 60°F	
pascals (Pa)	0.000295	inches of mercury (in Hg) at 32°F	
bars (10 ⁵ N/m ²)	29.53	inches of mercury (in Hg) at 32°F	
Energy			
kilojoules	0.9478	British thermal units (Btu)	
kilocalories	3.968	British thermal units (Btu)	
Thermal Conductance			
calories / sec - cm ² - °C	7373	Btu / hr - ft ² - °F	
watts / cm ² - °C	1761	Btu / hr - ft ² - °F	
Heat Flow			

TABLE OF CONTENTS

	<u>Page</u>
1.0 INTRODUCTION.....	1
2.0 EXPERIMENTAL.....	1
2.1 CIGARETTE IGNITION TEST	1
2.2 BUTANE "MATCH" TEST	4
2.3 PASS/FAIL CRITERIA "PROGRESSIVE SMOLDERING"	4
3.0 RESULTS	7
3.1 MARINE UPHOLSTERY FABRIC TEST	7
3.2 COMMERCIAL UPHOLSTERY FABRIC TEST	7
4.0 DISCUSSION.....	17
5.0 CONCLUSIONS/RECOMMENDATIONS.....	17
 APPENDIX A. PRELIMINARY DRAFT RECOMMENDATION ON FIRE TEST PROCEDURES FOR UPHOLSTERED FURNITURE	 A-1

Approved For	
Name	<input checked="" type="checkbox"/>
Date	<input type="checkbox"/>
Unit	<input type="checkbox"/>
Signature	
Fy.....	
Dir.....	
App.....	
Dist.....	
A-1	



LIST OF ILLUSTRATIONS

<u>Figure</u>		<u>Page</u>
1	TEST APPARATUS	
	a. Test Frame in Upright Position.....	2
	b. Test Frame in Open Position.....	3
	c. Test Frame in Open Position Showing Placement of Polyurethane Foam Cushion.....	5
	d. Test Frame in Open Position Showing Placement of Fabric.....	5
2	CIGARETTE PLACEMENT	
	a. Polyester/Cotton Blend Commercial Fabric.....	6
	b. Close-up of Cigarettes in Crevice.....	6
3	CIGARETTE IGNITION TEST-Marine Wool/Cotton Blend	
	a. Start of Test.....	8
	b. Fifteen Minutes into Test.....	8
	c. Thirty Minutes into Test.....	9
	d. End of Test - No Further Charring.....	9
4	CIGARETTE IGNITION TEST-Marine Naugahyde	
	a. Start of Test.....	10
	b. Five Minutes into Test.....	10
	c. Close-up of Material at End of Test.....	11
5	CHAR INFORMATION	
	a. Partially Consumed Cigarette.....	12
	b. Polyurethane Cushions at End of Test.....	12
6	BUTANE "MATCH" TEST-Marine/Cotton Blend	
	a. Start of Test.....	13
	b. Material After Twenty Seconds of Flame.....	13
7	BUTANE "MATCH" TEST-Marine Naugahyde	
	a. Start of Test.....	14
	b. Material After Twenty Seconds of Flame.....	14
8	BUTANE "MATCH" TEST-Commercial Polyester/Cotton Blend	
	a. Start of Test.....	15
	b. Material After Twenty Seconds of Flame.....	15

LIST OF TABLES

<u>Table</u>	<u>Page</u>
I CIGARETTE SMOLDERING RATES.....	4
II MARINE UPHOLSTERY FABRICS.....	16
III COMMERCIAL UPHOLSTERY FABRICS.....	16

ACKNOWLEDGMENTS

The author wishes to acknowledge the able assistance of Ms. Denise Baird who set up and conducted the experimental work. Also, a debt of appreciation is owed to Mr. Dewey Gillard who gave freely of his advice and services to assist in the laboratory work.

1.0 INTRODUCTION

The Sub-Committee on Fire Protection of the International Maritime Organization (IMO) has considered the need for fire test procedures for upholstered furniture. A proposed test procedure (FP 31/WP.4, Annex 4) has been successfully used by a number of laboratories to identify upholstery materials and constructions susceptible to ignition by cigarette or match flames. Therefore, a "Preliminary Draft Recommendation of Fire Test Procedures for Upholstered Furniture" was set out by the sub-committee in FP 32/WP.9, Annex 6 (see Appendix A). The purpose of this project is to make a technical assessment of the test method outlined in the draft recommendation.

The proposed standard is intended to be a minimum for safety of upholstered furniture. At present there are no IMO standards in this area of fire prevention. It is derived from, and is similar to, a British standard, BS 5852, Part 1. The principle of the test procedure is to subject an assembly of upholstery materials to two sources of ignition: one, a smoldering cigarette, and the other a butane flame source approximating the caloric output of a burning match. The test materials are installed on a small steel frame representing the frame of a sofa or chair. The ignition sources are applied to the joint between the seat and the back. The materials tested are representative of those used in the finished end-use product for its cover, filling, and other components. For the cigarette ignition source the assembly passes the test if no flaming is observed, and, no "progressive smoldering" is present after one hour. For the butane "match" test, a pass is recorded if no smoldering or flaming is observed after two minutes following the removal of the flame. The cigarette ignition part of the proposed test is similar to the voluntary Upholstered Furniture Action Council (UFAC) tests and NFPA 260A and 260B used in the United States. The butane match ignition source is not required by the above U.S. Standards.

2.0 EXPERIMENTAL

2.1 CIGARETTE IGNITION TEST

Experimental tests were conducted to provide information on the susceptibility of the model furniture assembly to ignition by cigarettes. These tests emphasized the evaluation of ignition characteristics for fabrics used in the marine industry. Additional tests were made to provide information regarding specific test procedures, and the ignition properties of selected commercial upholstery fabrics. All tests were conducted in accordance with the protocol specified in WP32/.9, Annex 6.

All materials for the Upholstered Furniture tests (cigarettes, cushions, and fabric) were conditioned in an environmental chamber for a minimum of 16 hours at 25 degrees C and 50% humidity. The materials were removed from the environmental chamber immediately before the start of each test.

The test protocol requires the use of an unfiltered cigarette with the following characteristics:

length :	68 mm
diameter :	8 mm
mass :	1 g. nominal
smoldering rate :	12.0 +/-3.0 min/50 mm

Therefore, a survey was made of cigarette brands to verify that cigarettes were available that met these requirements. For this survey each cigarette was marked at 5 mm and 55 mm from the tip. The cigarette was lighted and drawn until the tip glowed, being careful not to pass the 5 mm mark. It was then impaled on a wire spike, inserted a maximum of 13 mm into the unlit end of the cigarette, and the time required to smolder a distance of 50 mm was recorded. Four cigarettes from each of five packs per brand were tested. An average smoldering rate was then calculated for each brand. The data is presented in Table I. Based on the results of the smoldering rate tests, two brands of cigarettes were selected; Pall Mall and Players Navy Cut. Pall Mall is the brand of cigarette specified by the Upholstered Furniture Action Council. Players Navy Cut is available in the United Kingdom.

The test apparatus consisted of two rectangular frames hinged together. The apparatus was constructed so that it could be locked in an upright position. The framework was made from flat steel bar stock and expanded steel mesh. The apparatus is shown in both the upright and open positions in Figures 1A and 1B.

The "fire exposure" for ignition requires that a lit cigarette be placed on the apparatus in the crevice formed by the junction between the two cushions not less than 50 mm from the edge. Then the test is monitored for one hour for signs of combustion or "progressive smoldering". If combustion or "progressive smoldering" does not occur, a result of "pass" is recorded and the test repeated. According to the test specifications the repeat test may be performed concurrently with the first, provided that a distance of 50 mm between cigarettes is maintained. Evaluation of this method indicated that two cigarettes did not interfere with each other when the 50 mm distance was observed.

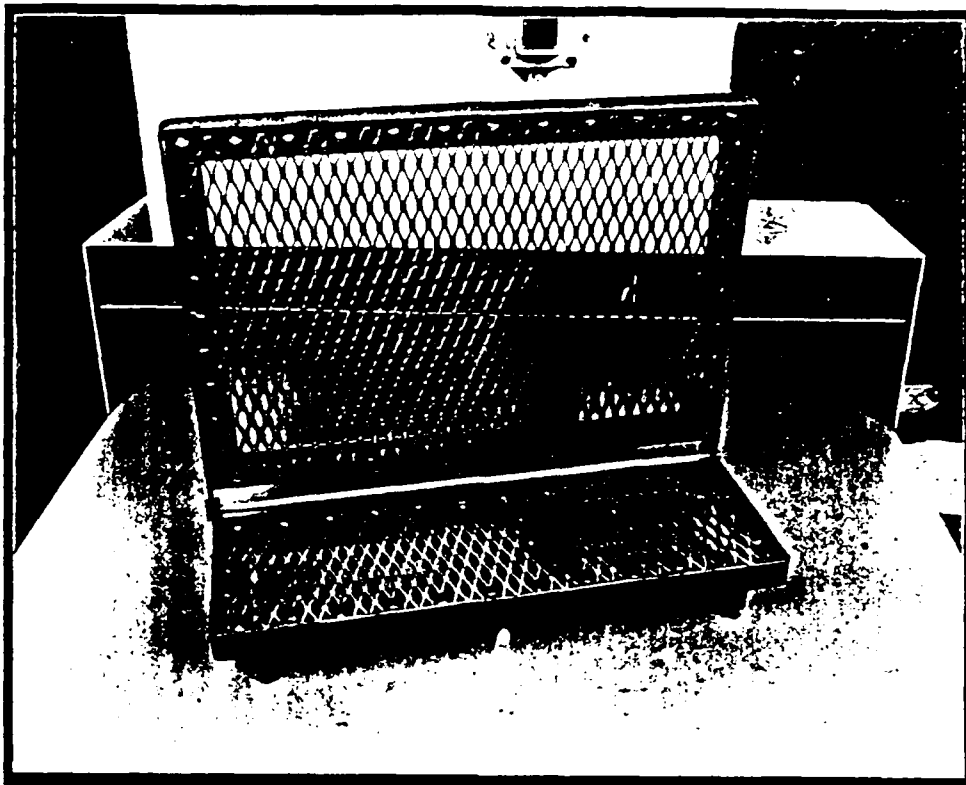

A. Test Frame in Upright Position

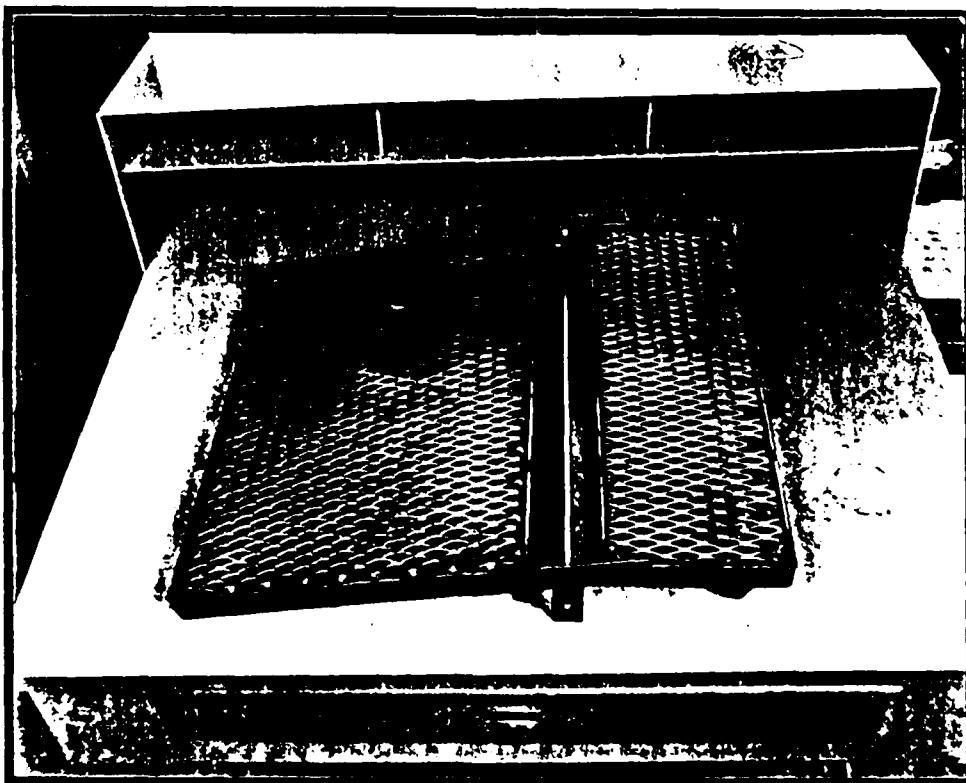

B. Test Frame in Open Position

FIGURE 1. Test Apparatus

TABLE I
CIGARETTE SMOLDERING RATES

Brand of Cigarette	Time to Burn 50 mm *
Raleigh	10.52
Pall Mall	10.92
Tareyton	9.21
Players (U.S. - filtered)	11.61
Players Special (filtered)	10.17
Players Navy Cut (Great Britain)	10.32
Lucky Strike	11.18
Camels	8.83

* Average value of 20 cigarettes for each brand.

During test operations, the test apparatus first was set in the open position with two polyurethane cushions in place as shown in Figure 1C. Then the fabric was placed over the cushions (Figure 1D), and the frame was put in an upright position and secured. Cigarettes were placed 50 mm from the edges of the apparatus. Figures 2A and 2B show placement of the cigarettes. The test was monitored at 5 minute intervals, recording vertical stain, vertical char, horizontal char, and the length of the cigarettes. Observations continued for up to one hour.

2.2 BUTANE "MATCH" TEST

A second test is a simulated "match" ignition test using a butane "match". The IMO requirements were met using a stainless steel burner tube (5/16 OD). The flame end of the tube was machined to the required 0.028 ID.

2.3 PASS/FAIL CRITERIA - "PROGRESSIVE SMOLDERING"

The use of the fire characteristic "progressive smoldering" as a pass/fail criteria was investigated. Since cigarette ignitions did not occur with the materials used in this study, progressive smoldering did not occur. To observe "progressive smoldering", the test conditions were modified by increasing the air draft over the test fixture. A clear indication of an

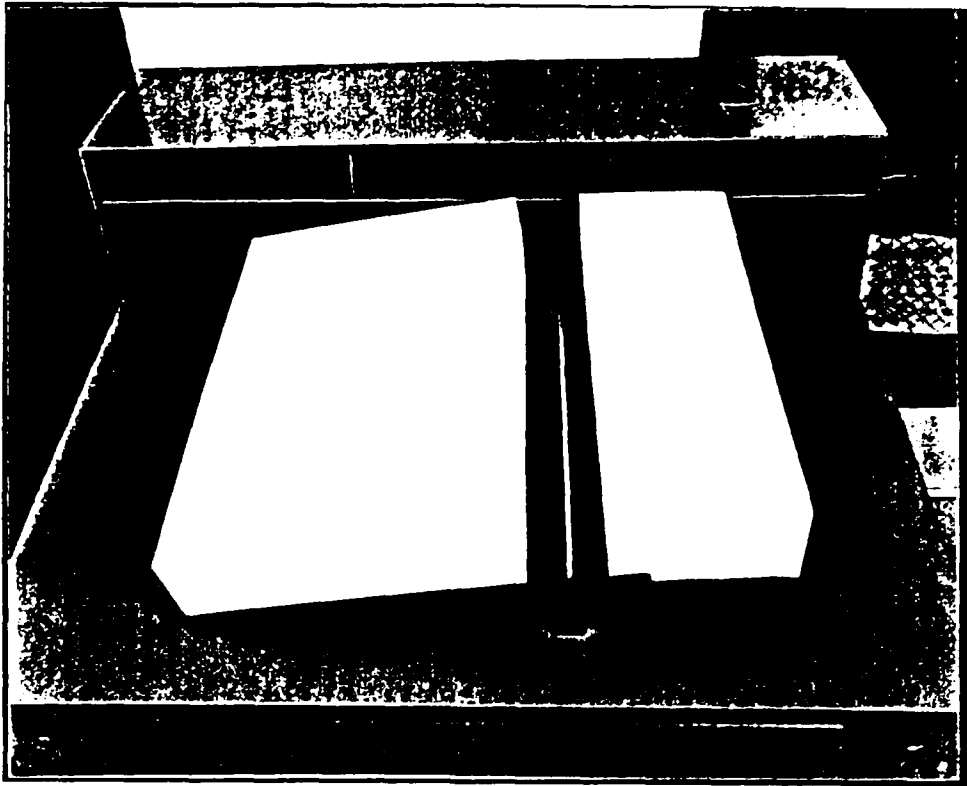

C. Test Frame in Open Position Showing Placement of Polyurethane Foam Cushions

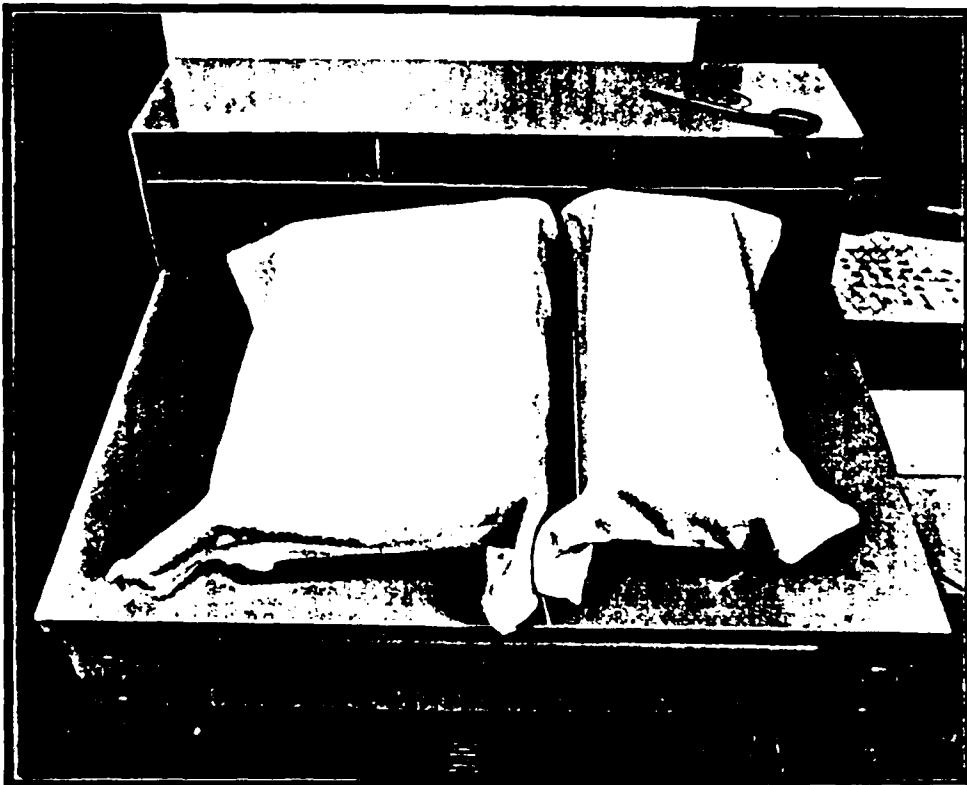

D. Test Frame in Open Position Showing Placement of Fabric

FIGURE 1. Test Apparatus (cont'd)

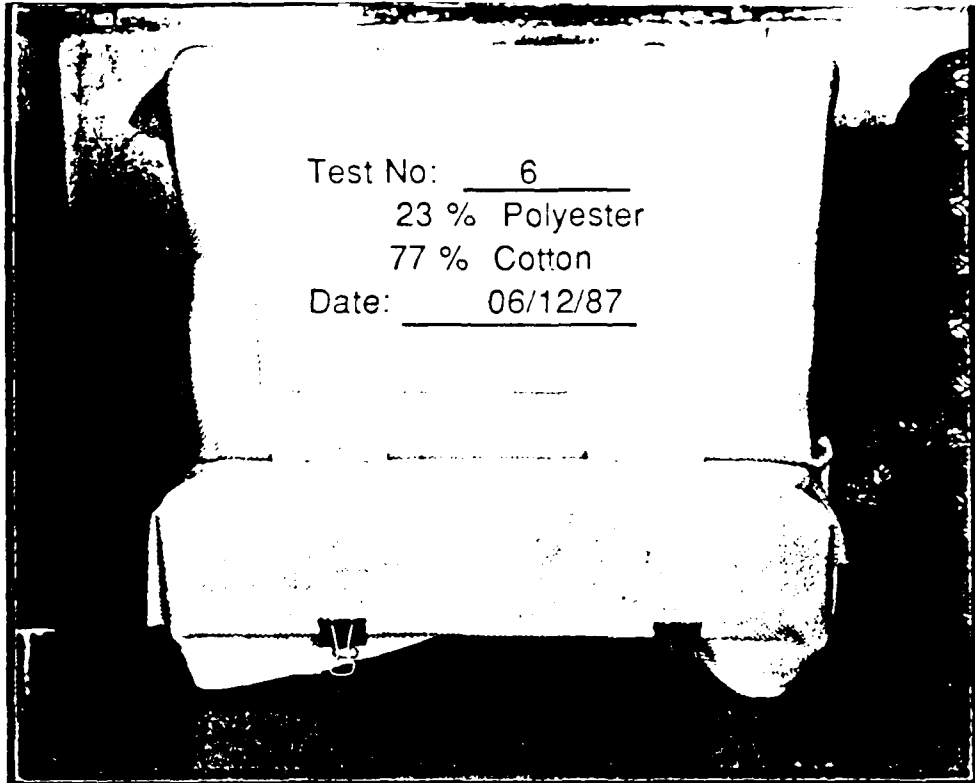

A. Polyester/Cotton Blend Commercial Fabric

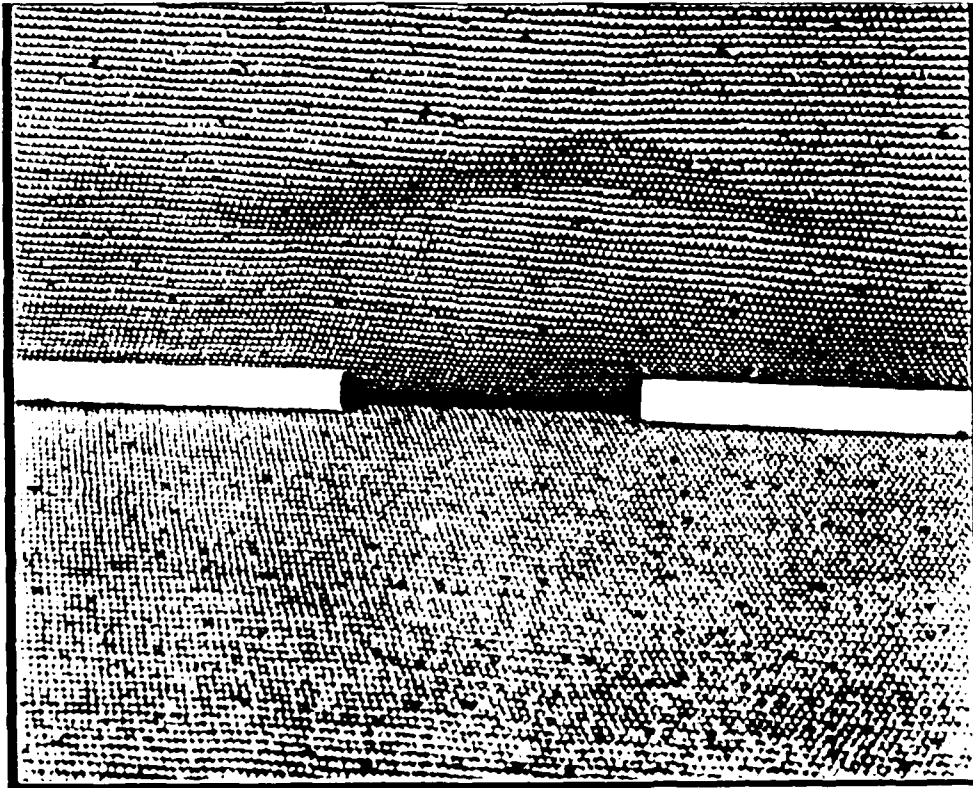

B. Close-up of Cigarettes in Crevice

FIGURE 2. Cigarette Placement

increase in "progressive smoldering" was visually observed by the increase in the rate of smoke evolution during the ignition process. Therefore, some materials which do ignite would be expected to exhibit an easily recognized "progressive smoldering".

3.0 RESULTS

3.1 MARINE UPHOLSTERY FABRIC TESTS

Six upholstery fabrics, currently sold for use in the maritime industry in the United States, were tested using the proposed test method. The fiber content of these fabrics included wool-cotton blends and 100% nylon or vinyl materials. The fabric weight ranged from 358 to 820 grams per square meter. Specific values of the chemical and physical properties and test results for each fabric are outlined in Table II. The values included in this table were obtained by an independent laboratory analysis of each material. Figure 3 shows the cigarette test progress for a marine wool/cotton blend. Figures 4A-C show a cigarette ignition test of material M-1, a marine naugahyde (Note in Figure 4C, the naugahyde melted, extinguishing the cigarette). Figure 5 shows the development of char in the polyurethane cushion for a modified test in which the air flow was increased to induce "progressive smoldering". Figures 6 and 7 show the flame development for a butane "match" test on two marine materials. All six marine fabrics passed the smoldering cigarette test. Five of the six materials passed the butane "match" test.

3.2 COMMERCIAL UPHOLSTERY FABRIC TESTS

Seven upholstery fabrics used for commercial furniture in the United States were also evaluated. The fiber content of these fabrics included polyester/cotton blends and 100% polyester materials. Their weight ranged between 214 to 440 grams/m². Specific values of the chemical and physical properties and test results for each fabric are outlined in Table III. All seven materials passed the smoldering cigarette test. Two materials passed the butane "match" test. Figure 8 shows the development of flaming for a commercial material which did not pass the butane "match" test.

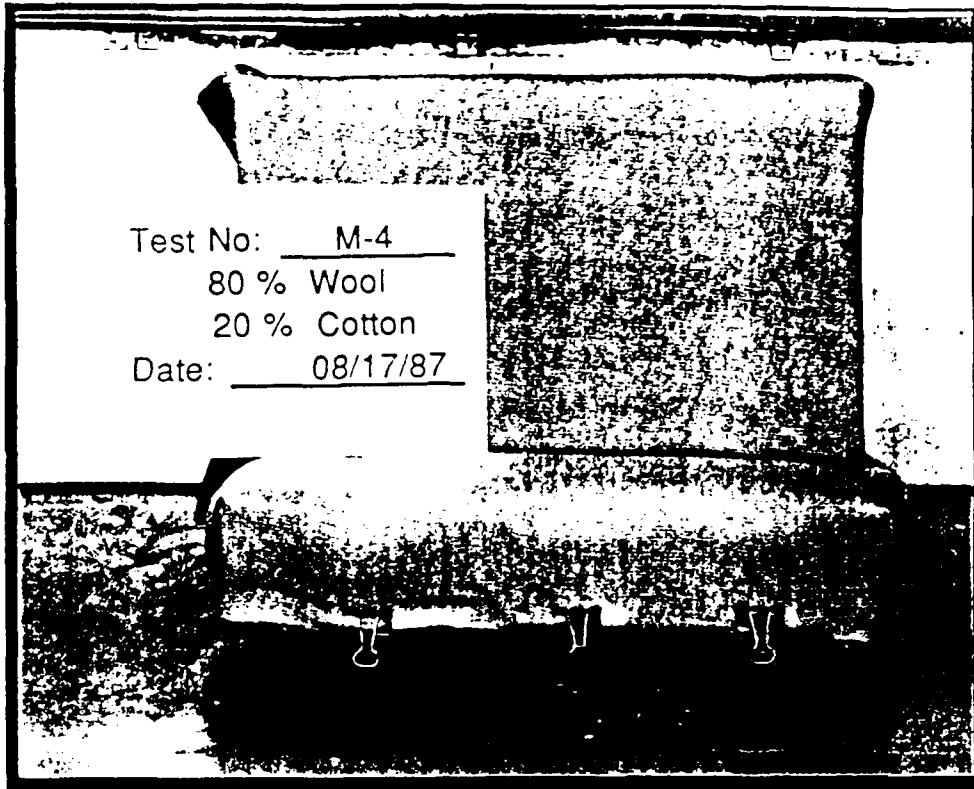

A. Start of Test

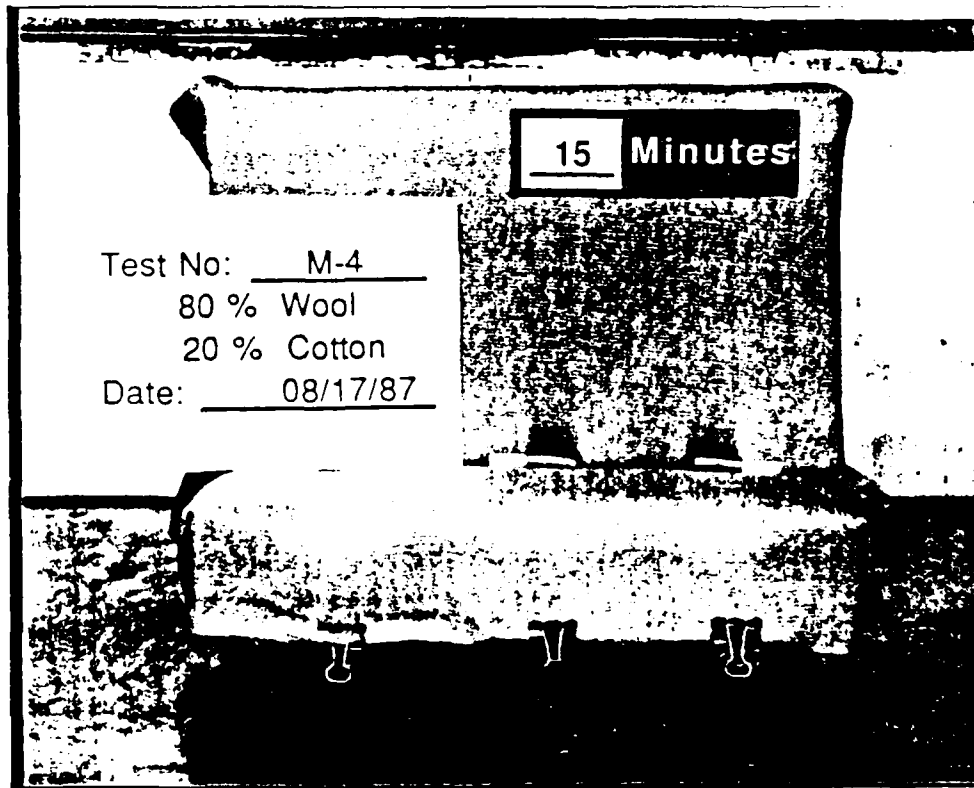

B. 15 Minutes Into Test

FIGURE 3. Cigarette Ignition Test-Marine Wool/Cotton Blend

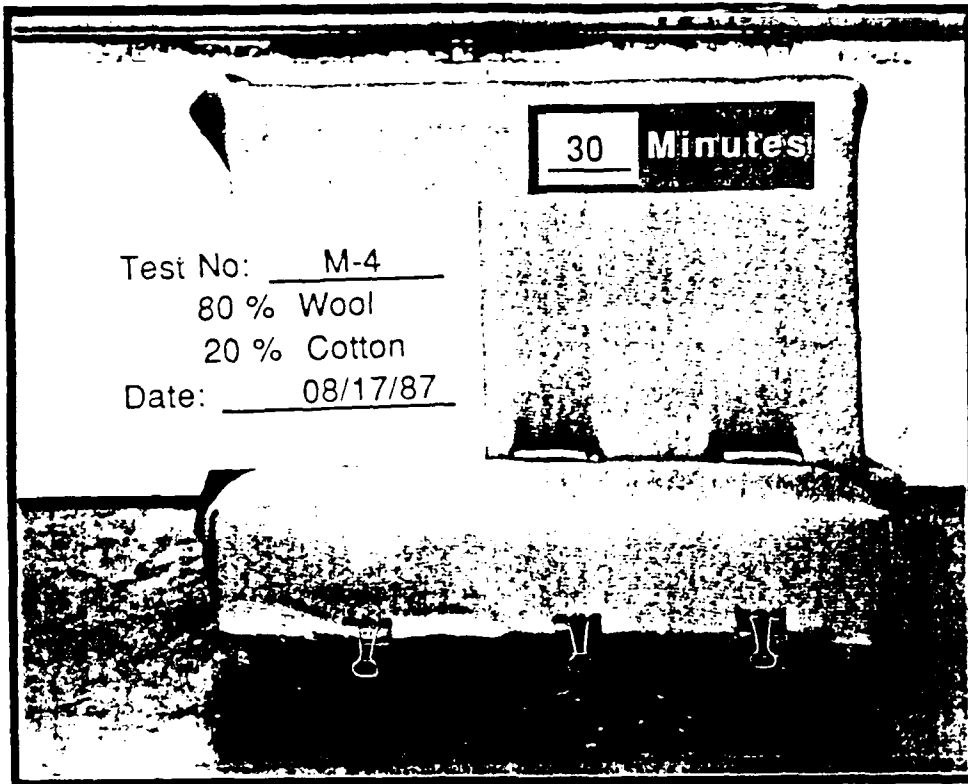

C. 30 Minutes Into Test

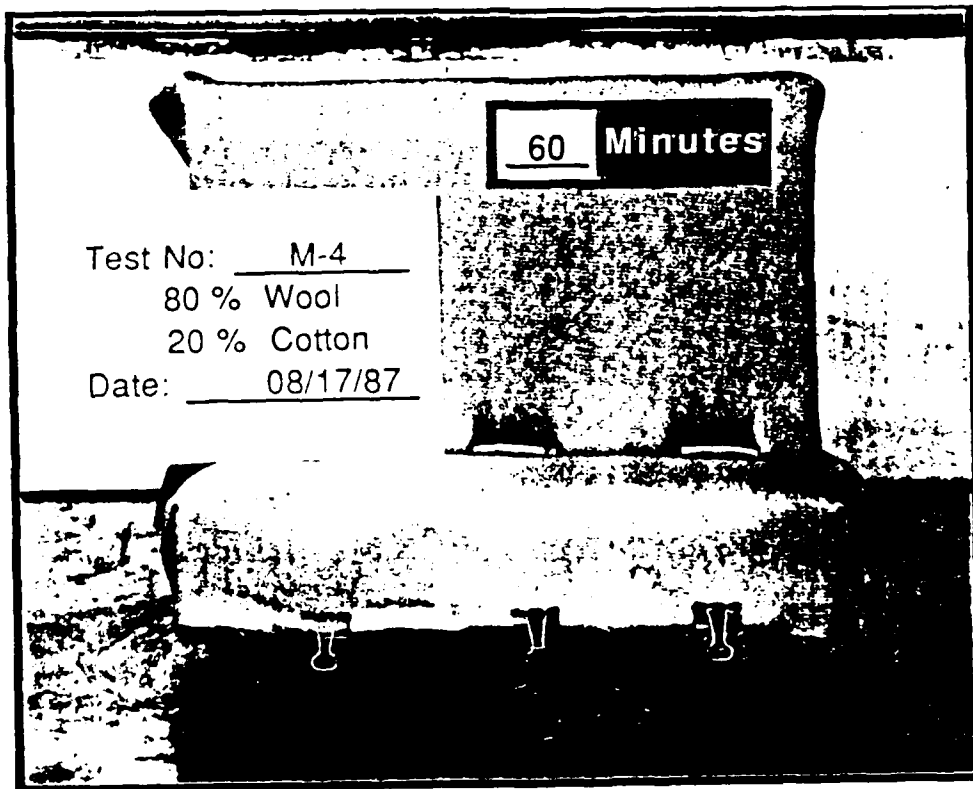

D. End of Test-No Further Charring

FIGURE 3. Cigarette Ignition Test-Marine Wool/Cotton Blend (cont'd)

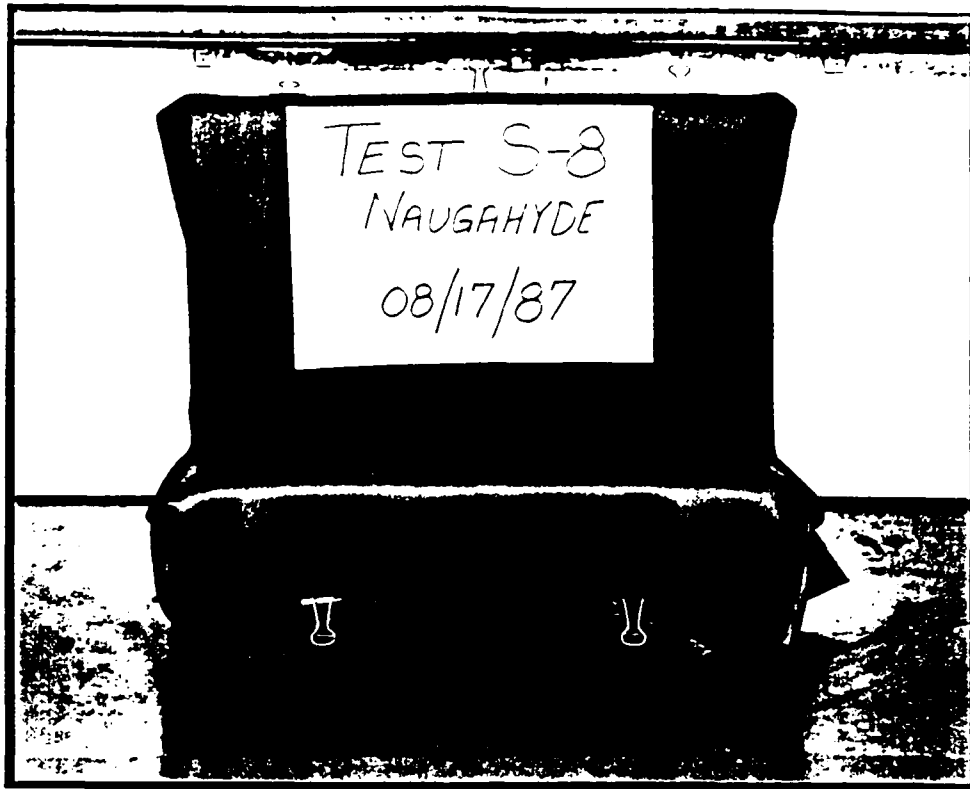

A. Start of Test

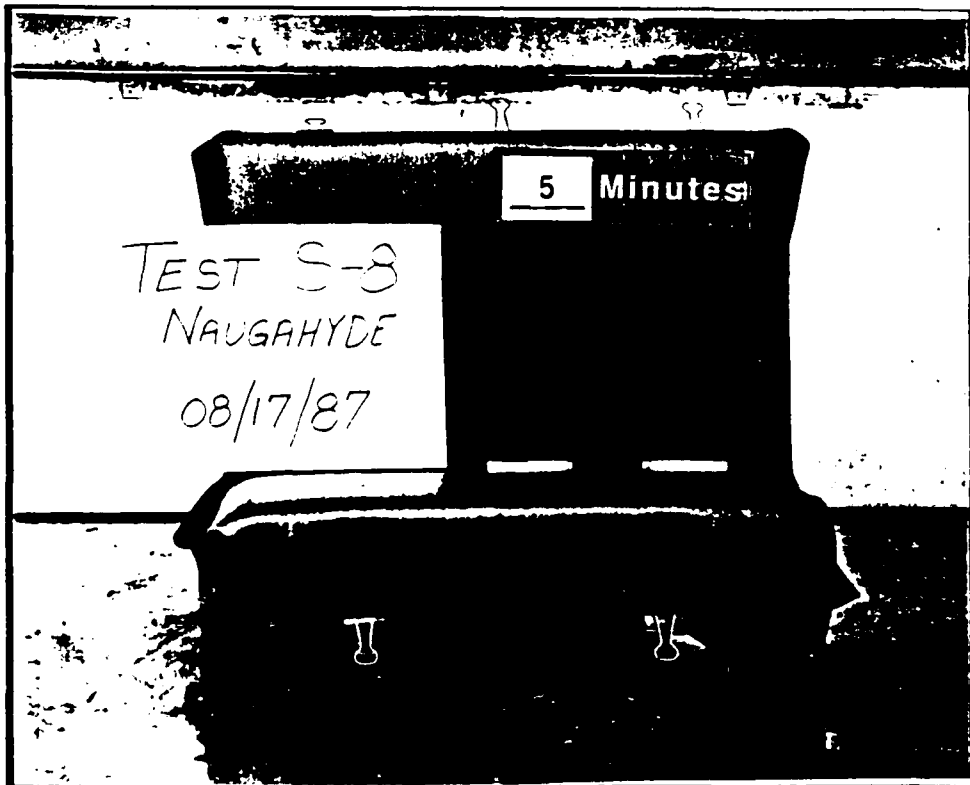

B. 5 Minutes Into Test

FIGURE 4. Cigarette Ignition Test-Marine Naugahyde

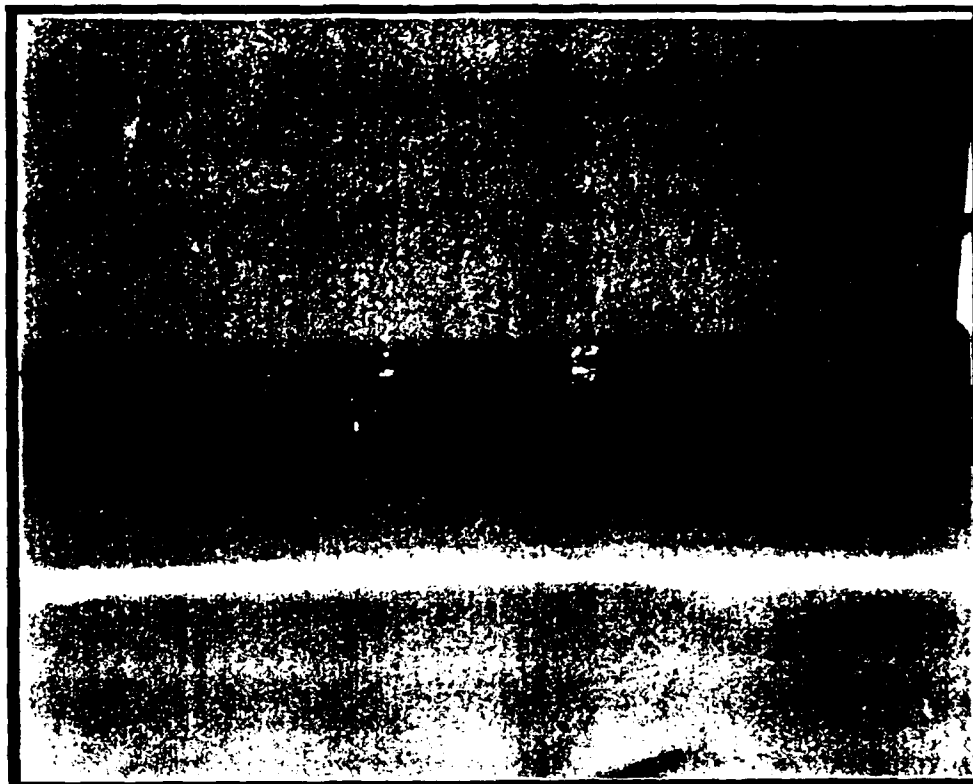

C. Close-up of Material at End of Test

FIGURE 4. Cigarette Ignition Test-Marine Naugahyde (cont'd)

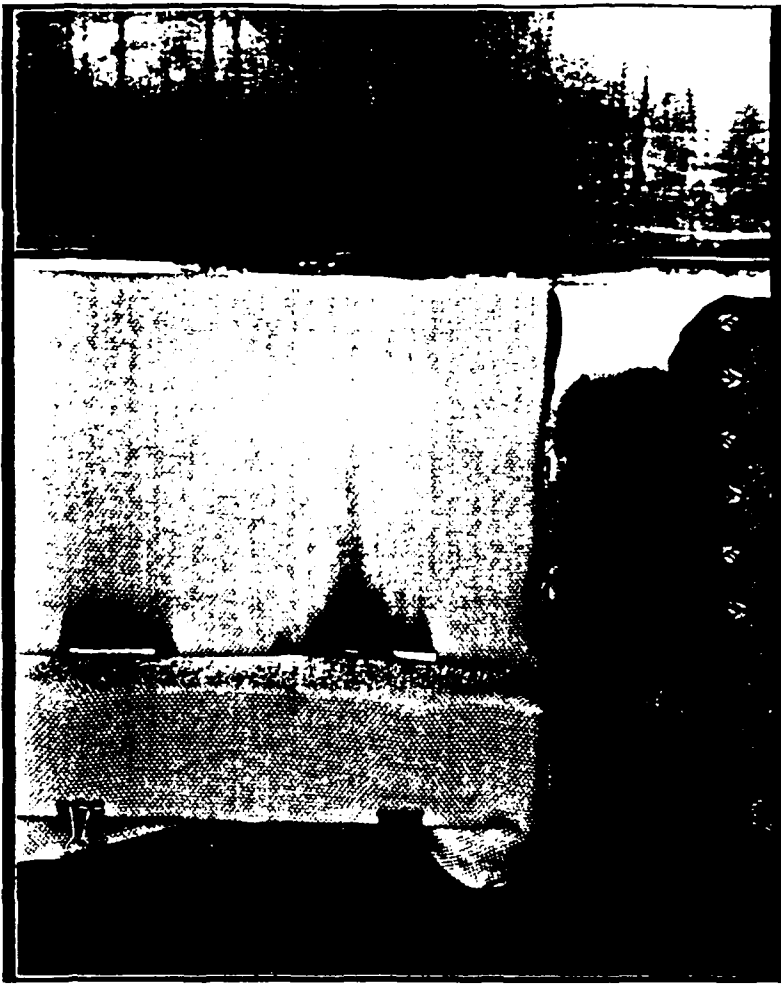

A. Partially Consumed Cigarette
(note charring of fabric)

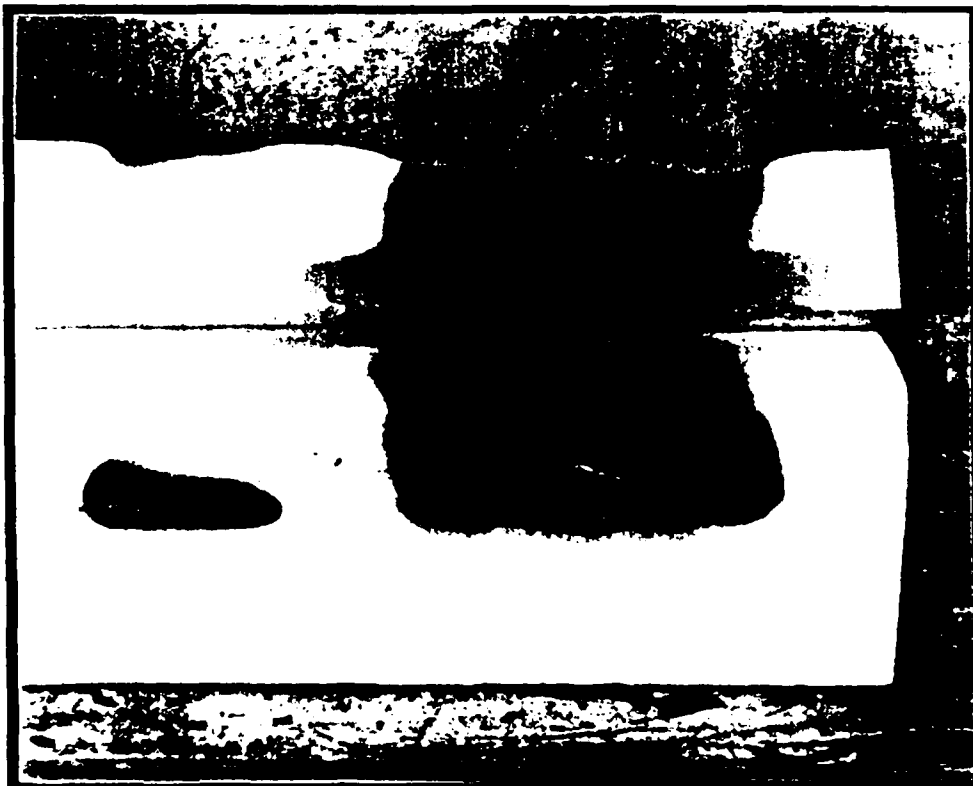

B. Polyurethane Cushions at End of Test

FIGURE 5. Char Formation

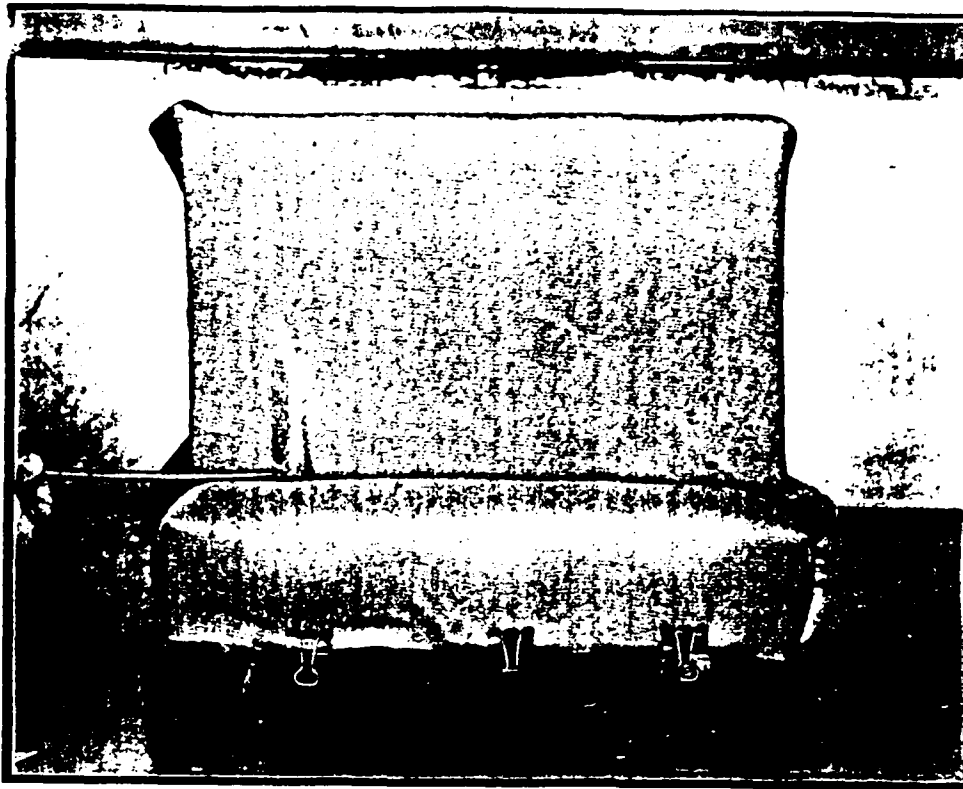

A. Start of Test

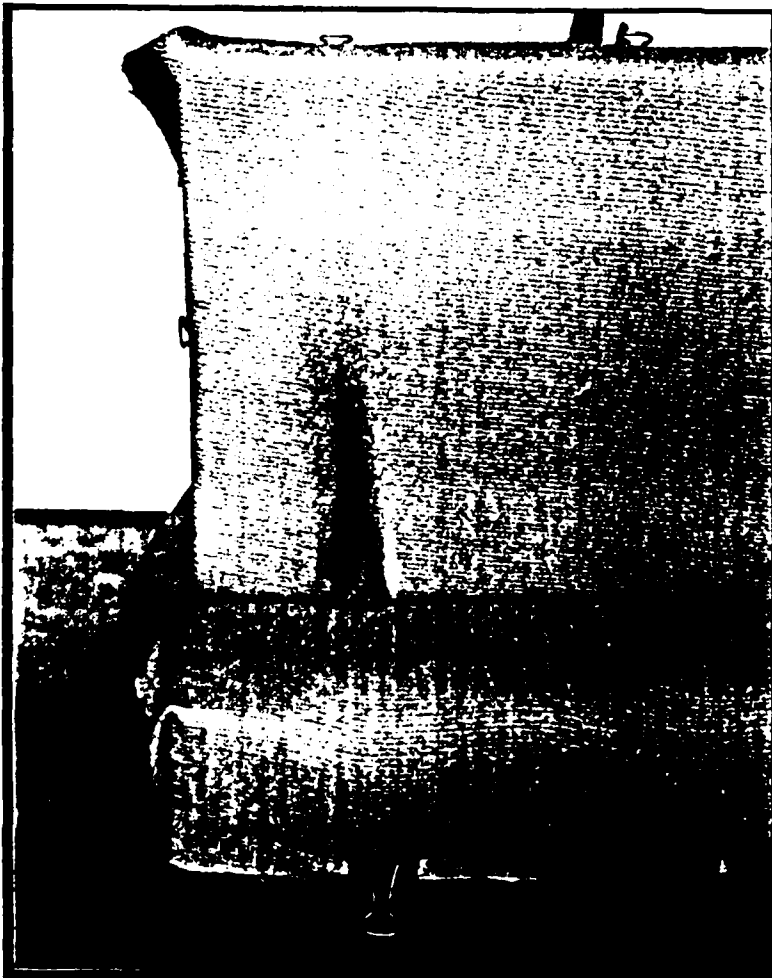

B. Material After Twenty
Seconds of Flame

FIGURE 6. Butane Match Test-Marine Wool/Cotton Blend

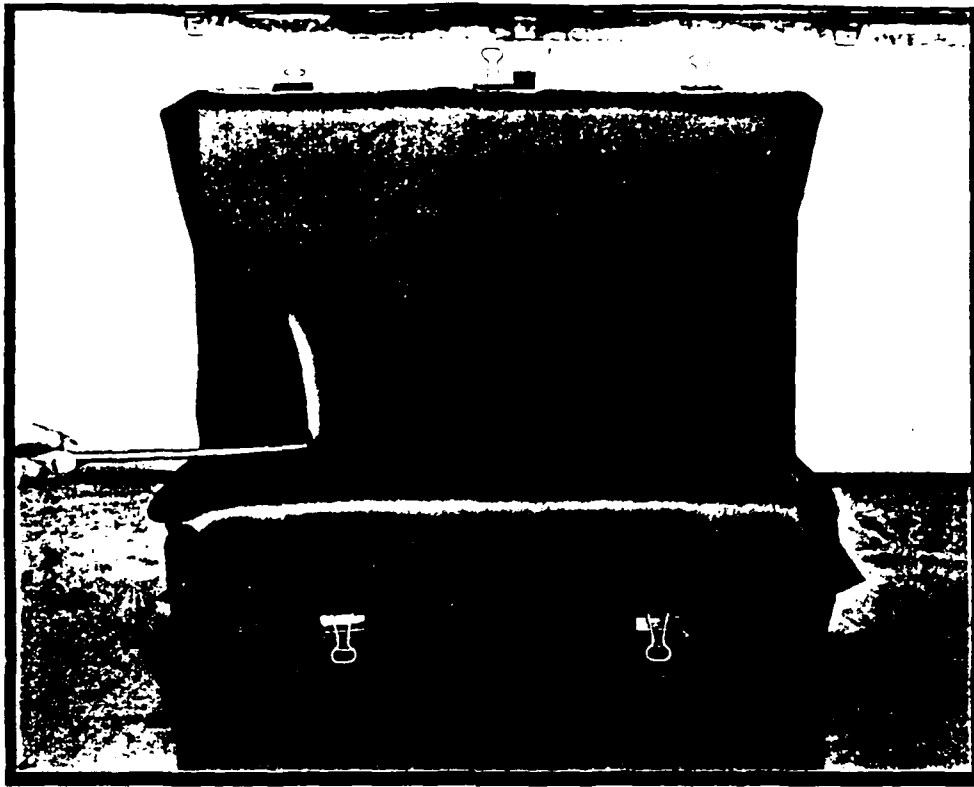

A. Start of Test

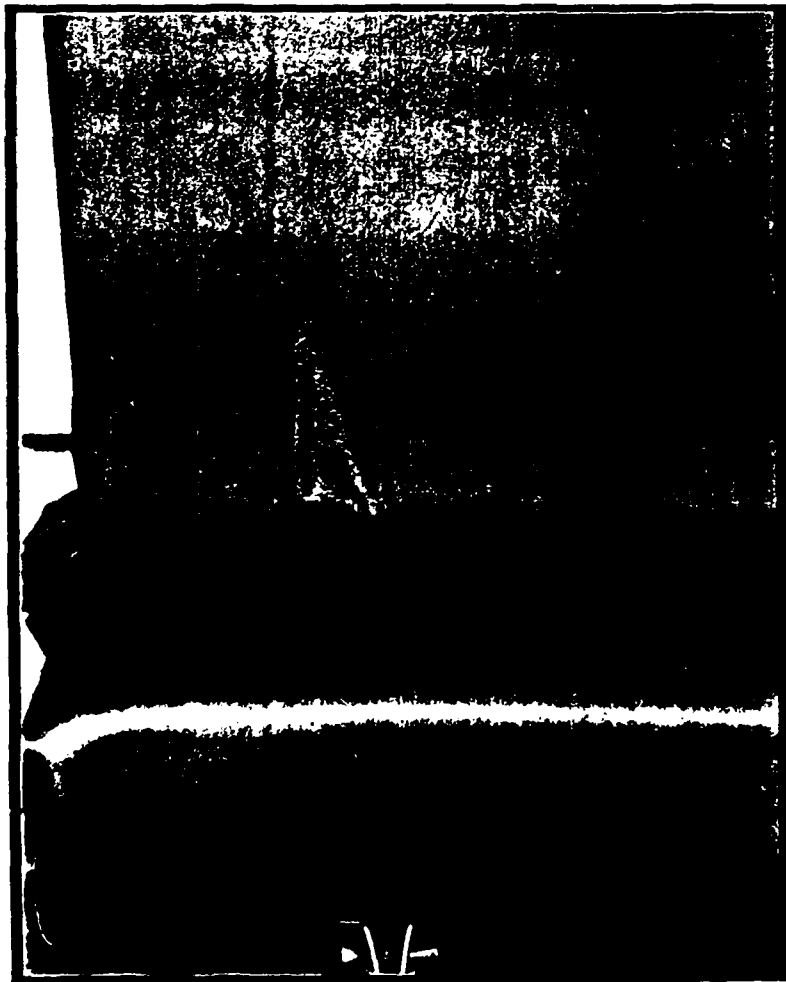

B. Material After Twenty Seconds of Flame

FIGURE 7. Butane Match Test-Marine Naugahyde

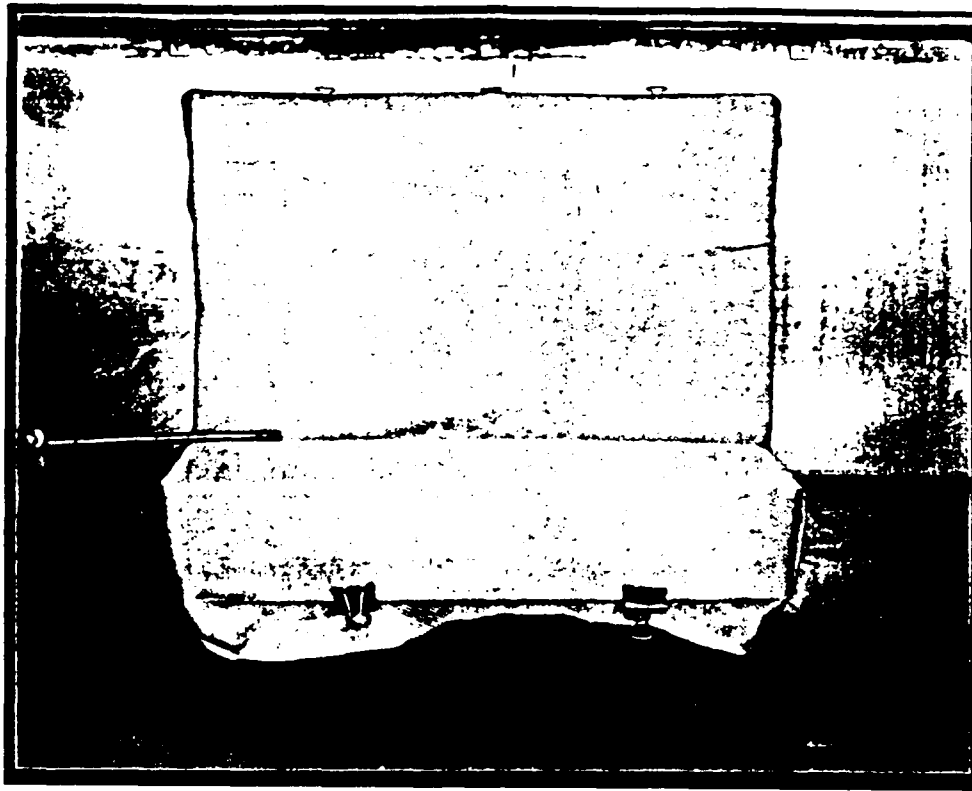

A. Start of Test

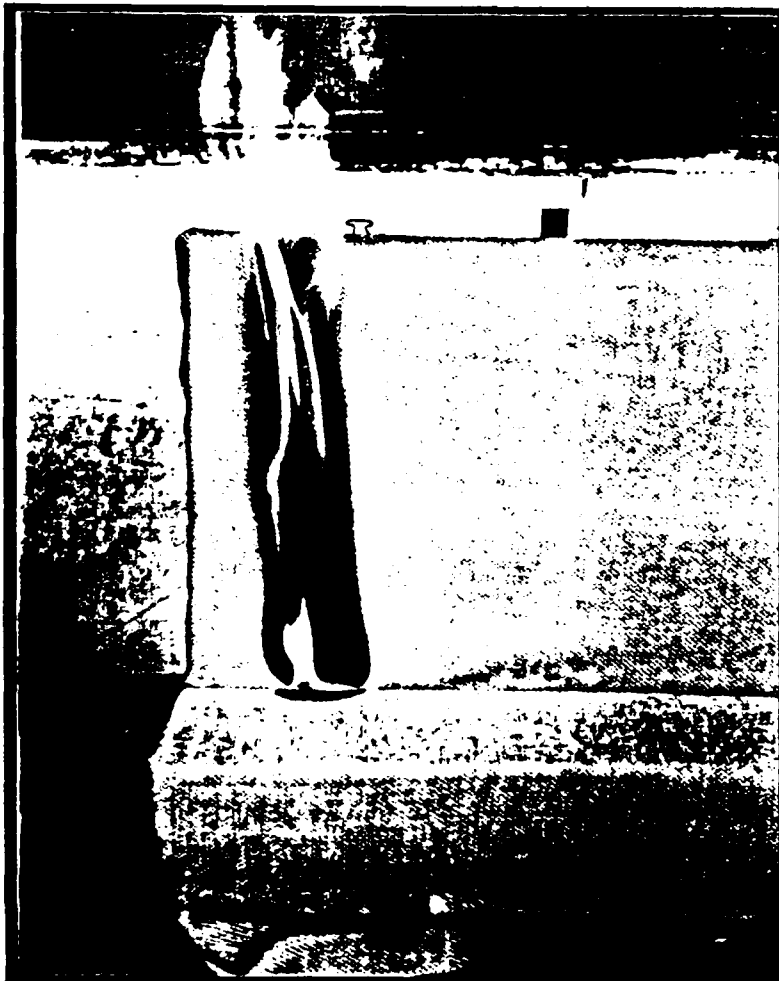

B. Material After Twenty Seconds of Flame

FIGURE 8. Butane Match Test-Commercial Polyester/Cotton Blend

TABLE II

MARINE UPHOLSTERY FABRICS

Test Mark	Fabric Weight (gms/m ²)	Fiber Content (percent)	Ends* (#/cm)	Picks** (#/cm)	Cigarette Test	Match Test
M-1	820	Vinyl	--	--	Pass	Pass
M-2	446	40 Cotton/60 Wool	5.2	7.1	Pass	Pass
M-3	358	35 Polyester-Cotton/ 65 Wool Face	12.6	15.0	Pass	Fail
M-4	546	80 Wool/20 Cotton	22.4	19.7	Pass	Pass
M-5	410	26 Nylon/ 73 Polyester	17.7	20.9	Pass	Pass
M-6	658	Nylon	4.7	5.5	Pass	Pass

TABLE III

COMMERCIAL UPHOLSTERY FABRICS

Test Mark	Fabric Weight (gms/m ²)	Fiber Content (percent)	Ends* (#/cm)	Picks** (#/cm)	Cigarette Test	Match Test
S-1	304	25 Polyester/75 Cotton/	14.9	24.0	Pass	Fail
S-2	214	Polyester	--	--	Pass	Pass
S-3	200	Polyester	39.8	17.3	Pass	Fail
S-4	400	77 Cotton/ 23 Polyester	5.9	15.0	Pass	Fail
S-5	246	2.5 Acetate/68.5 Nylon 29 Rayon	18.9	16.1	Pass	Fail
S-6	294	77 Cotton/ 23 Polyester	15.0	20.9	Pass	Fail
S-7	440	2 Acetate/70 Rayon/ 28 Polyester	28.3	55.1	Pass	Pass

* Warp threads

** Weft threads

4.0 DISCUSSION

The "Preliminary Draft Recommendation on Fire Test Procedures for Upholstered Furniture" is closely similar to the Upholstered Furniture Action Council test procedures developed as an industry standard in the United States. The major differences between the two methods are: (1) the UFAC test uses the length of char rather than the absence of "progressive smoldering" as a criteria for ignition by cigarettes; and (2), the UFAC tests do not include a butane "match" test. Other differences include the use of sheeting to cover the cigarette, and, the use of full scale test specimens for the UFAC procedures.

The inclusion of a flame ignition test such as the butane "match" test clearly restricts the use of materials currently in use in the United States for commercial fabrics. Although all the commercial fabrics passed the cigarette ignition test, less than 30% were able to pass the butane "match" test. One factor is fabric weight. The heavier thermoplastic fabrics required substantially more time than the lighter weight commercial fabrics before sufficient energy was transferred to melt the fabric and expose the polyurethane cushion. A second factor was the use of wool and wool/cotton blends in marine fabrics. These materials tend to form protective surface chars when exposed to the butane flame. Polyester blends and 100% polyester fabrics do not form highly protective chars but rather tend to liquefy and form holes exposing the cushion.

5.0 CONCLUSIONS/RECOMMENDATIONS

- o The proposed test method would have a minimum impact on United States manufactured upholstery materials used in the marine industries.
- o The proposed test method is relatively simple to set up and not difficult to use.
- o The butane "match" test may limit the use of some types of upholstery materials. These materials may include lightweight thermoplastic fibers such as are found in polyester blends. At present, these materials are not widely used in the marine industry in the United States.
- o Acceptance of the proposed test method is recommended for IMO use.

APPENDIX A

PRELIMINARY DRAFT RECOMMENDATION ON FIRE TEST PROCEDURES FOR
UPHOLSTERED FURNITURE

ANNEX 6PRELIMINARY DRAFT RECOMMENDATION ON FIRE TEST
PROCEDURES FOR UPHOLSTERED FURNITURE(Methods of test for the ignitability by smokers'
materials of upholstered composites for seating)

1 Scope

This test procedure prescribes methods for assessing the ignitability of material combinations e.g. covers and filling used in upholstered seating when subjected to either a smouldering cigarette or a lighted match as might be applied accidentally in the use of upholstered seats. It does not cover ignition caused by deliberate acts of vandalism.

2 Definition

For the purposes of this test procedure the following definition applies.

Progressive smouldering. An exothermic oxidation not accompanied by flaming which is self-propagating i.e. independent of the ignition source. It may or may not be accompanied by incandescence.

NOTE: In practice it has been found that there is usually a clear distinction between materials which may char under the influence of the ignition source but which do not propagate further (non-progressive) and those where smouldering develops in extent and spreads (progressive).

3 Principle

The principle is to subject an assembly of upholstery materials arranged to represent, in stylized form, the join between the seat and back (or seat and arm) surfaces of a chair to two sources of ignition; one being a smouldering cigarette, and the other a flaming source approximating to the calorific output of a burning match.

4 Health and safety operators

4.1 General

There is a considerable risk with these tests and precautions have to be taken.

4.2 Enclosure

For safety, the tests should be conducted in a suitable fume cupboard. If such a cupboard is not available, an enclosure should be constructed so that the tester is not exposed to the fumes (see clause 8).

4.3 Extinguishers

Accessible means of extinguishing the samples should be provided, for example a bucket of water, a fire blanket, or fire extinguisher.

5 Apparatus

5.1 Test rig

A suitable test rig is illustrated in figures 1 and 2. It shall consist of two rectangular frames hinged together and capable of being locked at right angles to each other.

The frames shall be made from nominal 25 mm x 3 mm steel flat bar and shall securely hold expanded steel platforms set 6 ± 1 mm below the top edge of the frames.

NOTE: The size of the mesh of the expanded steel is not critical, but a mesh size across the diagonals of approximately 28 mm x 6 mm has been found to be suitable.

The internal width and height of the back frame shall be 450 ± 2 mm x 300 ± 2 mm and the width and depth of the base frame 450 ± 2 mm x 150 ± 2 mm. A standard edging section may be used around the expanded steel to give protection and greater rigidity.

The sides of the frame shall extend beyond the back of each frame to provide for the hinge holes and to form the back legs. The hinge rod shall be of nominal 100 mm diameter steel, continuous across the back of the rig, and its axis 22.5 ± 0.5 mm beyond the back member of each frame.

The frames shall be lockable at right angles by a bolt or pin through each of the pairs of members forming the back legs. The front legs may be welded across the front corners of the base frame. The height of the legs shall be such as to leave a gap not less than 50 mm high between the base frame and the supporting surface.

For the tests the rig shall be sited within the enclosure (see 4.2) and the testing shall be performed in a substantially draught-free environment permitting an adequate supply of air.

5.2 Smouldering cigarette source

An untipped cigarette complying with the following requirements is needed:

length	68 mm approximately;
diameter	8 mm approximately;
mass	1 g nominal;
smouldering rate	12.0 ± 3.0 min/50 mm.

The smouldering rate shall be verified as follows on one sample from each batch of 10 cigarettes used.

Mark the cigarette, conditioned as described in 6.1, at 5 mm and 55 mm from the end to be lit. Light it as described in 8.2.1 and impale it horizontally in draught-free air on a horizontal wire spike inserted not more than 13 mm into the unlit end. Record the time taken to smoulder from the 5 mm to the 55 mm marks.

5.3 Butane flame ignition source

NOTE: This source has been designed to give a calorific output approximating to that of a burning match.

A burner tube consisting of a length of stainless steel tube (8.0 ± 0.1 mm outside diameter, 6.5 ± 0.1 mm internal diameter and 200 ± 5 mm in length) is connected by flexible tubing to a cylinder containing butane via a flowmeter, fine control valve, on-off valve (optional) and cylinder regulator providing an outlet pressure of 27.5 mbar*.

NOTE: Such steel tubing may be marketed as 5/16 in outside diameter, 0.028 in wall thickness. Where tubing of these dimensions is not readily available, stainless steel tubing of approximately similar dimensions may be used providing that the 50 mm length at the "flame" end of the tube is machined to the given sizes.

The flowmeter shall be precalibrated to supply a butane gas flow rate at 25°C of 45 ± 2 ml/min. The flexible tubing connecting the output of the flowmeter to the burner tube shall be 2.5 metres to 3.0 metres in length with an internal diameter of 7.0 ± 1.0 mm.

NOTE: Under these conditions the flame height is approximately 35 mm.

6 Atmosphere for conditioning and testing

6.1 Conditioning

The materials to be tested and the cigarettes shall be conditioned immediately before the test for 72 h in indoor ambient conditions and then for at least 16 h in an atmosphere having a temperature of 20 ± 5 °C and a relative humidity of $50 \pm 20\%$.

6.2 Testing

For testing, a substantially draught-free environment, having a temperature of 15°C to 30°C and a relative humidity of 20% to 70% shall be used.

* 1 mbar = 102 N/m^2 = 0.1 kPa.

7 Test pieces

7.1 General

The test piece materials shall be representative of the cover, filling and any other components to be used in the final assembly.

7.2 Cover material and fabric interliner

The cover size needed for each test is 800 ± 10 mm x 650 ± 10 mm. The long dimension shall be cut parallel to the selvedge. The cover may be constructed from smaller pieces of material provided that the location of the resulting seams does not occur within 100 mm of the area likely to be affected by the test.

The cover shall have triangular cut-outs 325 mm from one end on both sides. The cut-outs shall be positioned such that when assembled on the test rig the lie of any pile is down the back assembly and from the hinge to the front of the base frame. The size of these cut-outs shall be approximately 50 mm base and 110 mm high.

Where a fabric interliner is used it shall be cut to the same dimensions and in the same orientation as the cover for fitting to the test rig under the cover.

7.3 Upholstery filling

Two pieces, one 450 ± 5 mm x 300 ± 5 mm x 75 ± 2 mm thick, and the other 450 ± 5 mm x 150 ± 5 mm x 75 ± 2 mm thick are required for each test.

Some cushioning assemblies may consist of several layers that may be typically felt, wadding or different foams. In these cases the test pieces shall reproduce the upper 75 mm of the cushioning assembly.

Where the filling is less than 75 mm thick the test piece shall be built up to the required thickness by adding to the underside a further layer of the bottom material.

8 Test procedure

Warning

For safety, all tests should be carried out in a suitably constructed fume enclosure (see 4.2).

8.1 Preparation

8.1.1 Ensure that the means of extinguishment are close at hand (see 4.3).

8.1.2 Open out the test rig and thread the covering fabric and, if any, the fabric interliner behind the hinge bar.

8.1.3 Place the filling pieces under the covering fabric and, if any, the fabric interliner locating the filling pieces in the frame recesses, and allowing approximately 20 mm of fabric to wrap round the inside of the frames.

8.1.4 Lock the frames at right angles by the bolts or pins ensuring that the filling components are not displaced.

8.1.5 Fasten the fabric over the top, bottom and sides of the frame using clips and ensure that the fabric(s) is secured and under even tension.

8.2 Smouldering cigarette test

8.2.1 Light a cigarette (see 3.2) and draw air through it until the tip glows brightly. Not more than 8 mm of the cigarette shall be consumed in this operation.

8.2.2 Place the smouldering cigarette in position along the junction between the vertical and horizontal test pieces, allowing at least 50 mm from the nearest side edge, or from any marks left by any previous test, to the cigarette and simultaneously start the clock.

8.2.3 Observe the progress of combustion, and record any evidence of progressive smouldering (see clause 2) or flaming in the interior and/or cover.

NOTE: The detection of smouldering may be difficult and is eased by watching for smoke emerging at points at a distance from the cigarette. Smoke is most easily viewed by looking down a rising column by means of a mirror.

8.2.4 If progressive smouldering or if flaming of the upholstery components is observed at any time within a period of one hour of the placement of the cigarette, extinguish the test piece and record a failed result for the smouldering cigarette test.

8.2.5 If progressive smouldering or if flaming is not observed within the one hour period or if the cigarette fails to smoulder its complete length, repeat the test with a new cigarette placed in a fresh position not less than 50 mm from any previous test damage. If progressive smouldering or if flaming is not observed in this retest or if the cigarette fails to smoulder its complete length, record a pass result for the smouldering cigarette test unless the test piece fails the final examination specified in 8.4. Otherwise extinguish the test piece and record a failed result.

NOTE: This repeat test may be run concurrently with the first test.

8.3 Butane flame test

8.3.1 Light the butane emerging from the burner tube, adjust the gas flow to the appropriate rate (see 5.3) and allow the flame to stabilize for at least 2 minutes.

8.3.2 Position the burner tube axially along the junction between the seat and back so that the flame is not less than 50 mm from the nearest side edge or any marks left by any previous test, and simulataneously start the clock.

8.3.3 Allow the gas to burn for a period of 20 ± 1 s, then terminate by carefully removing the burner tube form the test pieces.

8.3.4 Observe for flaming or progressive smouldering (see clause 2) in the interior and/or cover. Disregard flames, afterglow, smoking or smouldering that cease within 120 seconds of the removal of the burner tube.

8.3.5 If flaming or progressive smouldering of the upholstery components is observed, extinguish the test piece. Record a failed result for the butane flame ignition source test.

8.3.6 If flaming or progressive smouldering is not observed, repeat the test at a fresh position as described in 8.3.2. If flaming or progressive smouldering is not observed in this retest, record a pass result for the butane flame ignition source test unless the test piece fails the final examination specified in 8.4. Otherwise extinguish the test piece and record a failed result.

8.4 Final examination

Cases of progressive smouldering undetected from the outside have been reported. Immediately after completion of the test programme on the assembly, dismantle and examine it internally for progressive smouldering. If this is present, extinguish the test piece and record a failed result for the relevant test source. For safety reasons ensure that all smouldering has ceased before the rig is left unattended.

Appendix A

Guidance notes

A.1 This test procedure prescribes methods for examining the ignitability, in defined circumstances, of an assembly of upholstery materials. These materials are combined together in a way intended to be generally representative of their end use in upholstered seating, and the ignition sources are a smouldering cigarette and a flame representing a burning match.

Thus the potential ignitability of using a particular cover, filling and interliner in combination can be assessed and this will allow the development of specifications concerned with ignition by smokers' materials. However, there are two important limitations, as follows:

- (a) The tests are concerned only with ignitability, and any controls of fire hazard have to consider, in addition, other aspects of fire performance such as rate of fire development, heat output, rate and quantity of smoke production and toxic gas evolution. Ideally, any attempts to reduce ignitability ought not to affect these other properties adversely.
- (b) The tests only measure the ignitability of a combination of materials used in upholstered seating and not of a particular finished item of furniture incorporating these materials. They give an indication of, but cannot guarantee, the ignition behaviour of the finished item of furniture. This limitation occurs because design features of the furniture can greatly affect its fire properties; any ignitability tests of a piece of furniture would therefore need to be carried out on the actual item and not on component materials or mock-ups. However, limited information on ignitability more specifically related to an intended design may be obtained as indicated in A.2 and A.3.

A.2 This test procedure prescribes laboratory tests for an assembly of materials which will give general guidance on the ignitability of finished furniture, but where more specific information is required, or in critical areas of end use, the principles may be applied to complete items or

components of furniture or to suitably modified test assemblies, some examples of which are given below. In such cases the sources described in 5.2 and 5.3 may be applied at positions which, as a general rule, correspond to those where the hazard of ignition occurs in use.

Example 1:

If a chair were to have a gap between the seat and back cushions, the placement of ignition sources in the angle of the test apparatus would be inappropriate. Instead, face ignition, where the sources are placed at the centre of the horizontal and vertical surfaces, would be more meaningful.

Example 2:

The test apparatus may be used to model the junction of any vertical and horizontal surfaces so that both arm and back constructions, if different, may be tested separately in conjunction with the seat.

Example 3:

The use of different materials in a back and seat of a chair may be reproduced in the test, two different cover fabrics being joined by sewing or staples behind the hinge bar.

Example 4:

If, in the final design, a loose cushion is to be placed on an upholstered seat platform, additional cigarette traps are produced between the loose cushion and the surrounding upholstery. This may be examined by constructing a loose cushion of the appropriate materials measuring $500 \pm 5 \text{ mm} \times 75 \pm 2 \text{ mm}$ to be placed on top of the horizontal surface of the normally assembled test arrangement.

A.3 Another way in which this test principle might be used is to give information about individual materials to be used in a combination. For example, the ability of a cover material to provide protection against ignition can be indicated by testing it in combination with a substrate of

known flammability; standard non-flame-retardant flexible polyether foam with a density of about 22 kg/m³ has been found to be suitable. Such information about the individual materials does not eliminate the need to test the actual combination, but it can help in the short-listing of material combinations and so reduce the overall amount of testing required.

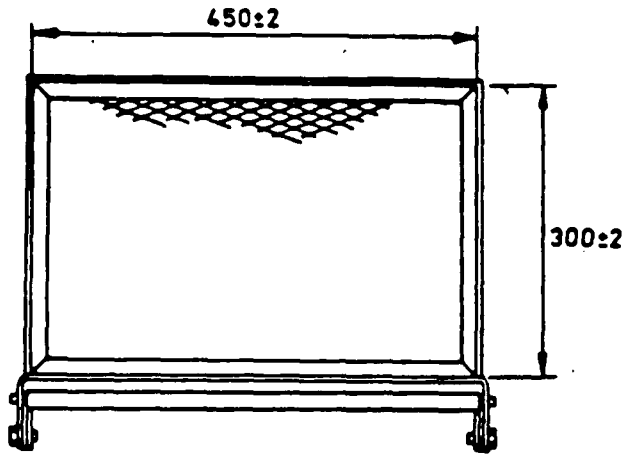

Front view
Scale 1:10

Unless tolerances are shown
dimensions are nominal.

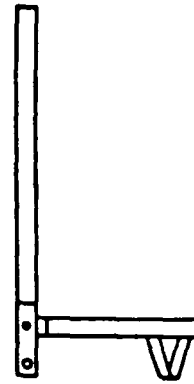

Side view

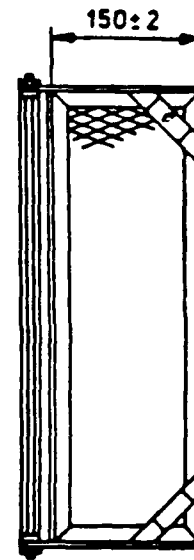

Inverted plan

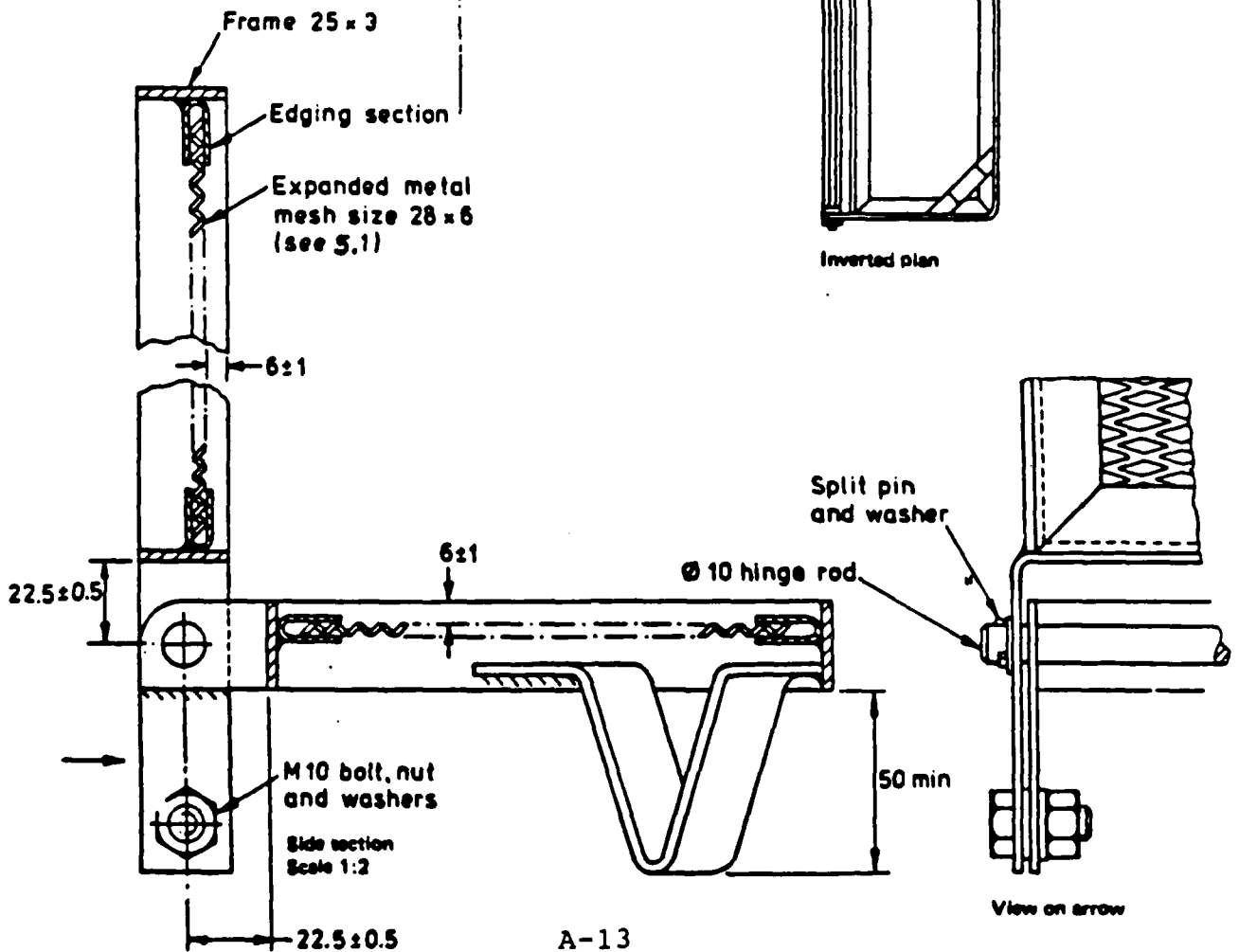

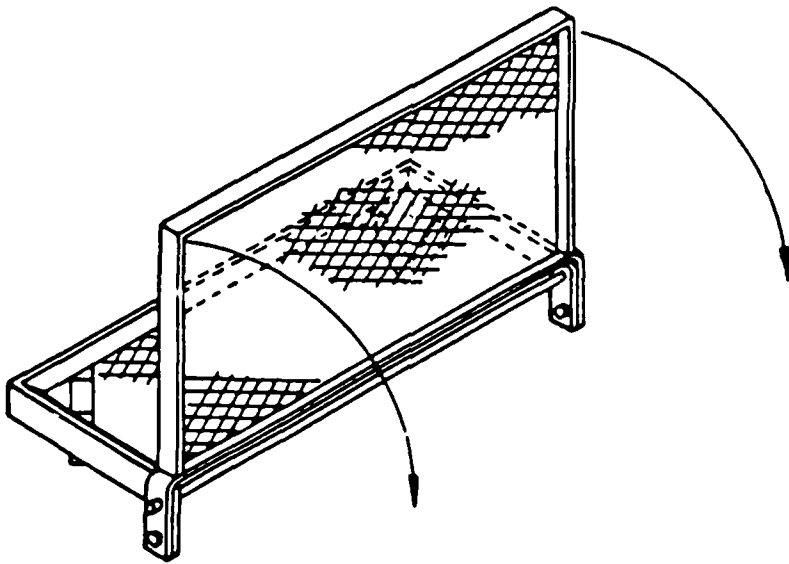

Test rig

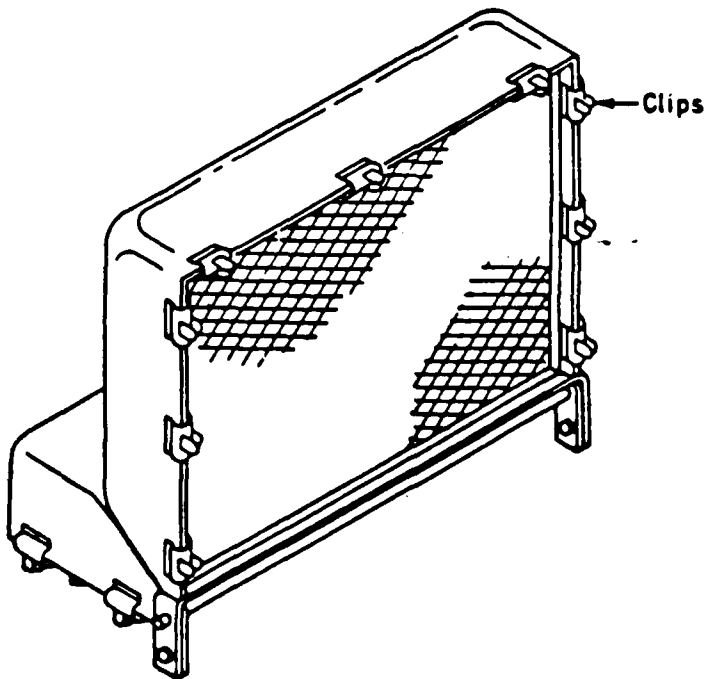

Test rig with cover and fillings

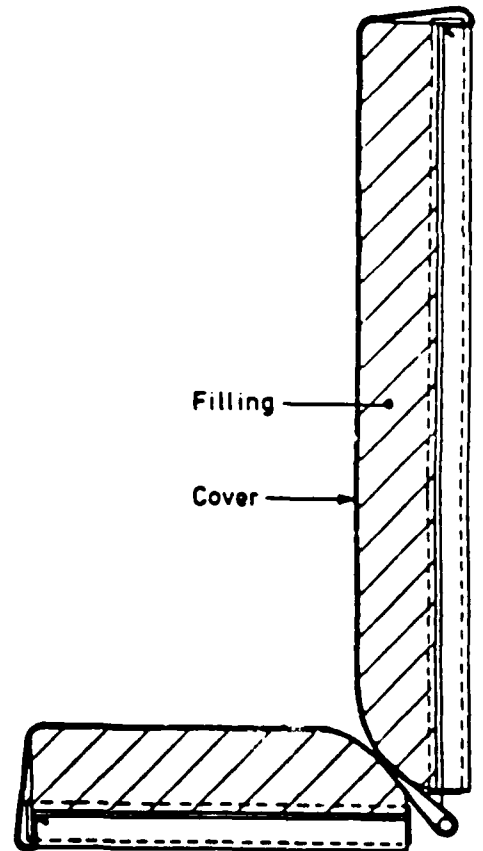

Vertical section

Figure 2. Test rig assembly