

2

Final Report

JUNE 1989

AD-A215 593

EVT 27-89

HALF-HIGH INTERMODAL SHIPPING
CONTAINER (ISC)
TRANSPORTABILITY TEST

DEC 20 1989
Dcs

STATEMENT A
Approved for public release
Distribution Unlimited

Distribution Unlimited

Prepared For:

U.S. Marine Corps
7th MEB
Twentynine Palms, CA 92278

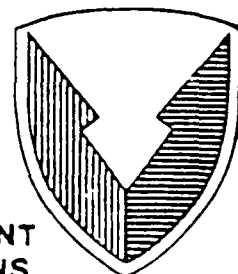

US ARMY
ARMAMENT
MUNITIONS
CHEMICAL COMMAND

US ARMY DEFENSE AMMUNITION
CENTER AND SCHOOL

EVALUATION DIVISION
SAVANNA, ILLINOIS 61074-9639

AVAILABILITY NOTICE

A copy of this report is furnished each attendee on automatic distribution. Additional copies or authority for reprinting of report may be obtained by written request from Director, U.S. Army Defense Ammunition Center and school, SMCAC-DEV, Savanna, IL 61074-9639.

DISTRIBUTION INSTRUCTIONS

Destroy this report when no longer needed. Do not return.

* * *

Citation of trade names in this report does not constitute an official endorsement.

* * *

The information contained herein will not be used for advertising purposes.

REPORT DOCUMENTATION PAGE

Form Approved
OMB No. 0704-0188

1a. REPORT SECURITY CLASSIFICATION UNCLASSIFIED			1b. RESTRICTIVE MARKINGS			
2a. SECURITY CLASSIFICATION AUTHORITY			3. DISTRIBUTION / AVAILABILITY OF REPORT UNLIMITED			
2b. DECLASSIFICATION / DOWNGRADING SCHEDULE						
4. PERFORMING ORGANIZATION REPORT NUMBER(S) EVT 27-89			5. MONITORING ORGANIZATION REPORT NUMBER(S)			
6a. NAME OF PERFORMING ORGANIZATION U.S. Army Defense Ammunition Center and School		6b. OFFICE SYMBOL (If applicable) SMCAC-DEV	7a. NAME OF MONITORING ORGANIZATION			
6c. ADDRESS (City, State, and ZIP Code) ATTN: SMCAC-DEV Savanna, IL 61074-6939			7b. ADDRESS (City, State, and ZIP Code)			
8a. NAME OF FUNDING / SPONSORING ORGANIZATION U.S. Marine Corps		8b. OFFICE SYMBOL (If applicable)	9. PROCUREMENT INSTRUMENT IDENTIFICATION NUMBER			
8c. ADDRESS (City, State, and ZIP Code) 7th MEB Twentynine Palms, CA 92278			10. SOURCE OF FUNDING NUMBERS			
			PROGRAM ELEMENT NO.	PROJECT NO.	TASK NO.	WORK UNIT ACCESSION NO.
11. TITLE (Include Security Classification) Half-High Intermodal Shipping Container (ISC) Transportability Test						
12. PERSONAL AUTHOR(S) A. C. McIntosh, Jr						
13a. TYPE OF REPORT FINAL		13b. TIME COVERED FROM _____ TO _____		14. DATE OF REPORT (Year, Month, Day) 1989 June	15. PAGE COUNT 30	
16. SUPPLEMENTARY NOTATION						
17. COSATI CODES			18. SUBJECT TERMS (Continue on reverse if necessary and identify by block number)			
FIELD	GROUP	SUB-GROUP				
19. ABSTRACT (Continue on reverse if necessary and identify by block number) The U.S. Army Defense Ammunition Center and School (USADACS), Evaluation Division, (SMCAC-DEV), was tasked by the U.S. Marine Corps, 7th Marine Expeditionary Brigade, FMF, to perform validation of the half-high (4 feet by 4 feet by 20 inches) Intermodal Shipping Container (ISC) for transportability, storage of ammunition aboard Maritime Prepositioned Ships (MPS). A sample container was supplied and tested with an inert load of 155MM M548 projectiles. Blocking and bracing procedures supplied by the Storage and Outloading Division (SMCAC-DEO) provided for 36 pallets of inert ammunition. The loaded container was subjected to Rail, Road Hazard, 30-Mile Road Trip, Panic Stops, Washboard and Shipboard Transportation Simulator (STS) tests. The half-high ISC satisfied all test requirements. Two problem areas were identified as a result of testing this container. The first problem area was the requirement for load baffling to prevent damage to the container roof bows. As a result, the payload was decreased by six ammunition pallets. The second problem was the angle of the loading ramp available to USADACS. When extended for loading, the ramp						
20. DISTRIBUTION / AVAILABILITY OF ABSTRACT <input checked="" type="checkbox"/> UNCLASSIFIED/UNLIMITED <input type="checkbox"/> SAME AS RPT. <input type="checkbox"/> DTIC USERS			21. ABSTRACT SECURITY CLASSIFICATION UNCLASSIFIED			
22a. NAME OF RESPONSIBLE INDIVIDUAL Thomas J. Michels, Chief, Evaluation Division			22b. TELEPHONE (Include Area Code) 815-273-8080	22c. OFFICE SYMBOL SMCAC-DEV		

19. Abstract (CONT)

presented a step to the loading forklift that prevented driving onto the container floor. To overcome this problem, an access ramp was placed at the end of the container loading ramp that provided easy forklift access.

U.S. ARMY DEFENSE AMMUNITION CENTER AND SCHOOL
Evaluation Division
Savanna, IL 61074-9639

REPORT NO. EVT 27-89

HALF-HIGH INTERMODAL SHIPPING CONTAINER

TRANSPORTABILITY TEST

TABLE OF CONTENTS

PART	PAGE NO.
1. GENERAL.....	1-1
A. Introduction.....	1-1
B. Authority.....	1-1
C. Objective.....	1-2
D. Conclusions.....	1-2
E. Recommendations.....	1-2
F. Approval.....	1-2
2. ATTENDEES.....	2-1
3. TEST PROCEDURES.....	3-1
4. TEST RESULTS.....	4-1
5. TEST PLANS.....	5-1

PART 1

INTRODUCTION

A. BACKGROUND. The U.S. Army Defense Ammunition Center and School (USADACS), Evaluation Division (SMCAC-DEV) was tasked by the U.S. Marine Corps, 7th Marine Expeditionary Brigade, FMF, to validate half-high (4 feet by 4 feet by 20 inches) ISC for transportability, storage of ammunition aboard Maritime Prepositioned Ships (MPS). A sample container was supplied for testing with an inert load of 155MM M548 projectiles. Blocking and bracing procedures supplied by the Storage and Outloading Division (SMCAC-DEO) provided for 36 pallets of inert ammunition. The loaded container was subjected to Rail, Road Hazard, 30 Mile Road Trip, Panic Stops, Washboard and STS tests. The half-high ISC satisfied all test requirements.

B. AUTHORITY. This test was conducted in accordance with mission responsibilities delegated by the U.S. Army Armament, Munitions and Chemical Command (AMCCOM), Rock Island, IL. Reference is made to Change 4, 4 October 1974, to AR 740-1, 23 April 1971, Storage and Supply Operations; AMCCOM R 10-17, 13 January 1986, Mission and Major Functions of USADACS.

C. OBJECTIVE. The objective of these tests was to determine if the Marine Corps half-high ISC would be suitable to road, ship and rail transportation environment.

D. CONCLUSIONS. The half-high ISC safely retained the inert load of 155MM M548 projectiles when subjected to Rail, Road and STS tests. Difficulties were observed in forklift access into the container during loading and unloading. Positioning of the roof bow mounts prevented testing with a full capacity load of projectiles.

E. RECOMMENDATIONS. It is recommended that the roof bow mounts be mounted to the top side rail so that more cube is available for loading. Consideration should be given to modifying the loading ramp design for easier access of the smaller forklifts (4,000 pounds).

E. APPROVAL. The Marine Corps half-high ISC is approved for the transportation of ammunition.

PART 2

ATTENDEES

Mr. A. C. McIntosh
Test Engineer
AV 585-8989
815-273-8989

Director
U.S. Army Defense Ammunition Center
and School
ATTN: SMCAC-DEV
Savanna, IL 61074-9639

Mr. Quinn Hartman
General Engineer
AV 585-8992
815-273-8992

Director
U.S. Army Defense Ammunition Center
and School
ATTN: SMCAC-DEV
Savanna, IL 61074-9639

Mr. Greg Willis
AV 585-8084
815-273-8084

Director
U.S. Army Defense Ammunition Center
and School
Storage and Outloading Division
ATTN: SMCAC-DEO
Savanna, Illinois 61074-9639

CWO-2 H. James Clay
AV 952-6512/7228
619-368-6512

Commander
U.S. Marine Corps
7th MEB
Twentynine Palms, CA 92278

PART 3

TEST PROCEDURES

A. RAIL IMPACT TEST. The test load or vehicle should be positioned in/on a railcar. For containers, the loaded container shall be positioned on a container chassis and securely locked in place using the twist locks at each corner. The container chassis shall be secured to a railcar. Equipment needed to perform the test includes the specimen (hammer) car, five empty railroad cars connected together to serve as the anvil, and a railroad locomotive. These anvil cars are positioned on a level section of track with air and hand brakes set and with the draft gear compressed. The locomotive unit pulls the specimen car several hundred yards away from the anvil cars and, then, pushes the specimen car toward the anvil at a predetermined speed, disconnects from the specimen car about 50 yards away from the anvil cars, and allows the specimen car to roll freely along the track until it strikes the anvil. This constitutes an impact. Impacting is accomplished at speeds of 4, 6, and 8 mph in one direction and at a speed of 8 mph in the opposite direction. The 4 and 6 mph impact speeds are approximate; the 8 mph speed is a minimum. Impact speeds are to be determined by using an electronic counter to measure the time required for the specimen car to traverse an 11-foot distance immediately prior to contact with the anvil cars.

B. HAZARD COURSE. The specimen being tested will be subjected to the road hazard course. Using a suitable truck/tractor or tactical vehicle, the vehicle/specimen of test method No. 1 shall be towed/driven over a hazard course two times at a speed of approximately 5 mph. The speed may be increased or decreased, as appropriate, to produce the most violent load response.

C. 30 MILE ROAD TRIP. Using a suitable truck/tractor and trailer, or tactical vehicle, the tactical vehicle/specimen load shall be driven/towed for a total distance of at least 30 miles over a combination of roads surfaced with gravel, concrete, and asphalt. Test route shall include curves, corners, railroad crossings, cattle guards, stops, and starts. The test vehicle shall travel at the maximum speed suitable for the particular road being traversed, except as limited by legal restrictions. This step provides for the tactical vehicle/specimen load to be subjected to three full airbrake stops while traveling in the forward direction and one in the reverse direction while traveling down a 7 percent grade. The first three stops are at 5, 10, and 15 mph, while the stop in the reverse direction is of approximately 5 mph.

D. WASHBOARD COURSE. Using a suitable truck/tractor, and/or tactical vehicle, the specimen shall be towed/driven over the washboard course at a speed which produces the most violent response in the particular test load as indicated by the resonant frequency of the suspension system beneath the load).

E. SHIPBOARD TRANSPORTATION SIMULATOR. The test load (specimen) shall be positioned onto the STS and securely locked in place using the cam lock at each corner. Using the procedure detailed in the operating instructions, the STS shall be started oscillating at an amplitude of 30 inches plus 2 inches, either side of center and a frequency of 2 cycles-per-minute (30 seconds plus 2 seconds total roll period). This frequency shall be maintained for at least 15 minutes during which time the load will be observed for apparent defects that could cause a safety hazard. The frequency of oscillation shall then be increased to 4 cycles-per-minute (15 seconds plus 1 second roll period) and the apparatus operated for 2 hours. If an inspection of the load does not indicate an impending failure, the frequency of oscillation shall be further increased to 5 cycles-per-minute (12 seconds plus 1 second cycle time).

and the apparatus operated for 4 hours. The operation does not necessarily have to be continuous; however, no change or adjustments to the load or load restraints shall be permitted at any time during the test. After once being set in place, the test load (specimen) shall not be removed from the apparatus until the test has been completed or is terminated.

US ARMY DEFENSE AMMUNITION CENTER AND SCHOOL

TRANSPORTABILITY ROAD COURSE

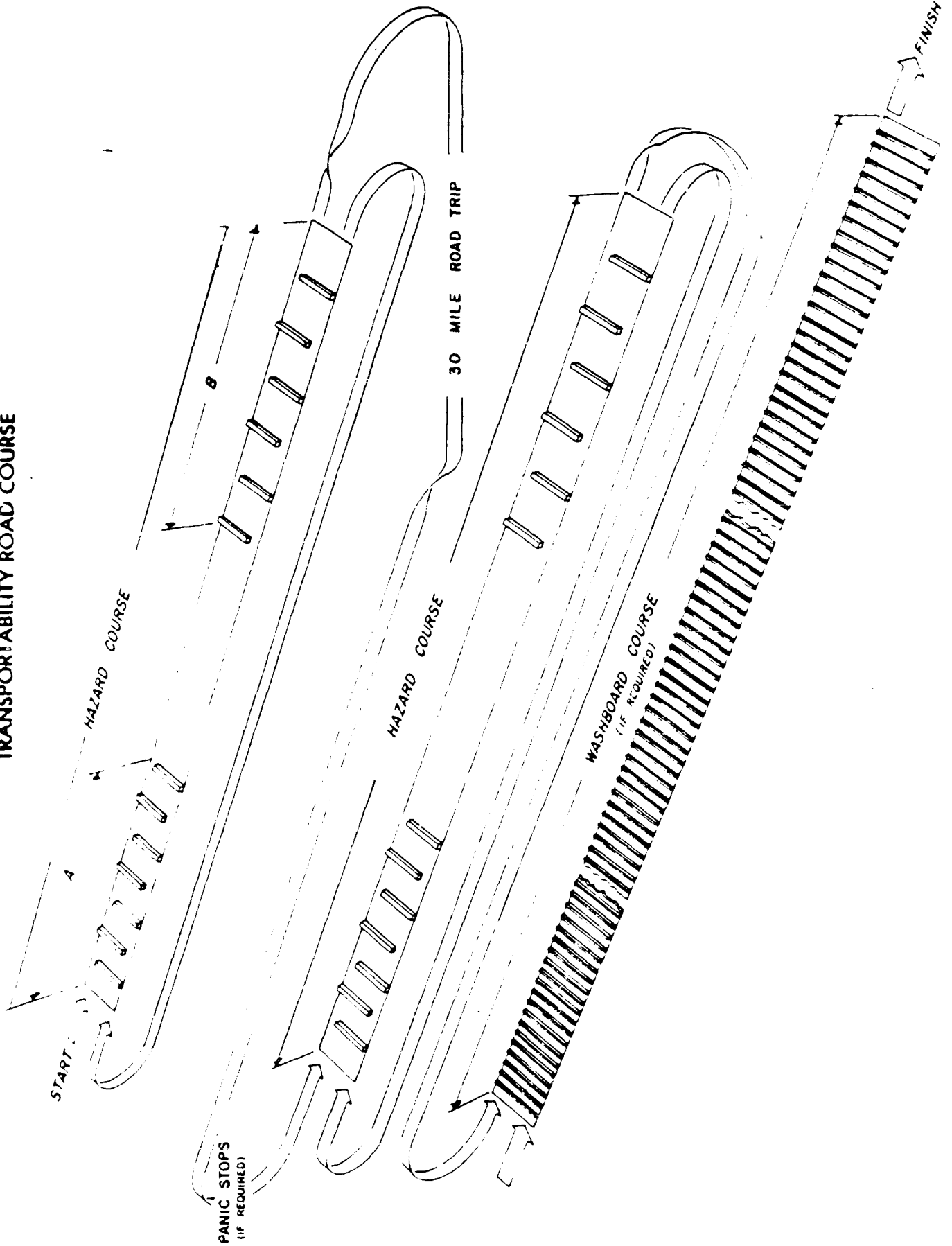

PART 4

TEST RESULTS

RAIL IMPACT DATA

TEST NO. 1

DATE: 23 MAY 1989

TEST SPECIMEN: TOFC with Half-High ISO container.

TEST CAR NO. TTX 153621 LT. WT. 74,800 pounds

LADING AND DUNNAGE WT. 37,570 pounds

TOTAL SPECIMEN WT. 112,370 pounds

BUFFER CAR (5 CARS) WT. 250,000 pounds

<u>IMPACT NO.</u>	<u>END STRUCK</u>	<u>VELOCITY (MPH)</u>	<u>IMPACT FORCE</u>	<u>REMARKS</u>
1	forward	3.81	120,860	Pallet tops chipping at rear of container.
2	forward	6.59	133,067	Container slipped 2 inches on chassis. Load shifted 5/8 inch to rear.
3	forward	8.65	238,007	Cracked forward end gate. Bulk of loading on gate center beam (2 by 5). Deflection caused upper beam to crack.
4	reverse	8.81	259,400	Cracked rear end gate beam. Identical damage cited in Impact 3.

RESULTS FROM THE RAIL IMPACT TEST OF THE
MARINE CORPS HALF-HEIGHT CONTAINER
DATE: 23 MAY 1989

TAPE CHANNEL 6 : RAIL COUPLER FORCE

TEST	SPEED MPH	PEAK VALUE POUNDS	DURATION MILLISECONDS	AREA POUNDS-SECONDS
IMPACT 1	3.81	120860.24	59.53	4685.15
IMPACT 2	6.59	133067.28	78.68	7518.17
IMPACT 3	8.65	238007.36	36.41	5675.70
IMPACT 4 (REVERSE)	8.81	259400.14	36.21	6181.03

RAIL IMPACT TEST OF MARINE CORPS HALF-HEIGHT CONTAINER
IMPACT 1: 3.81 MPH, DATE: 23 MAY 1989

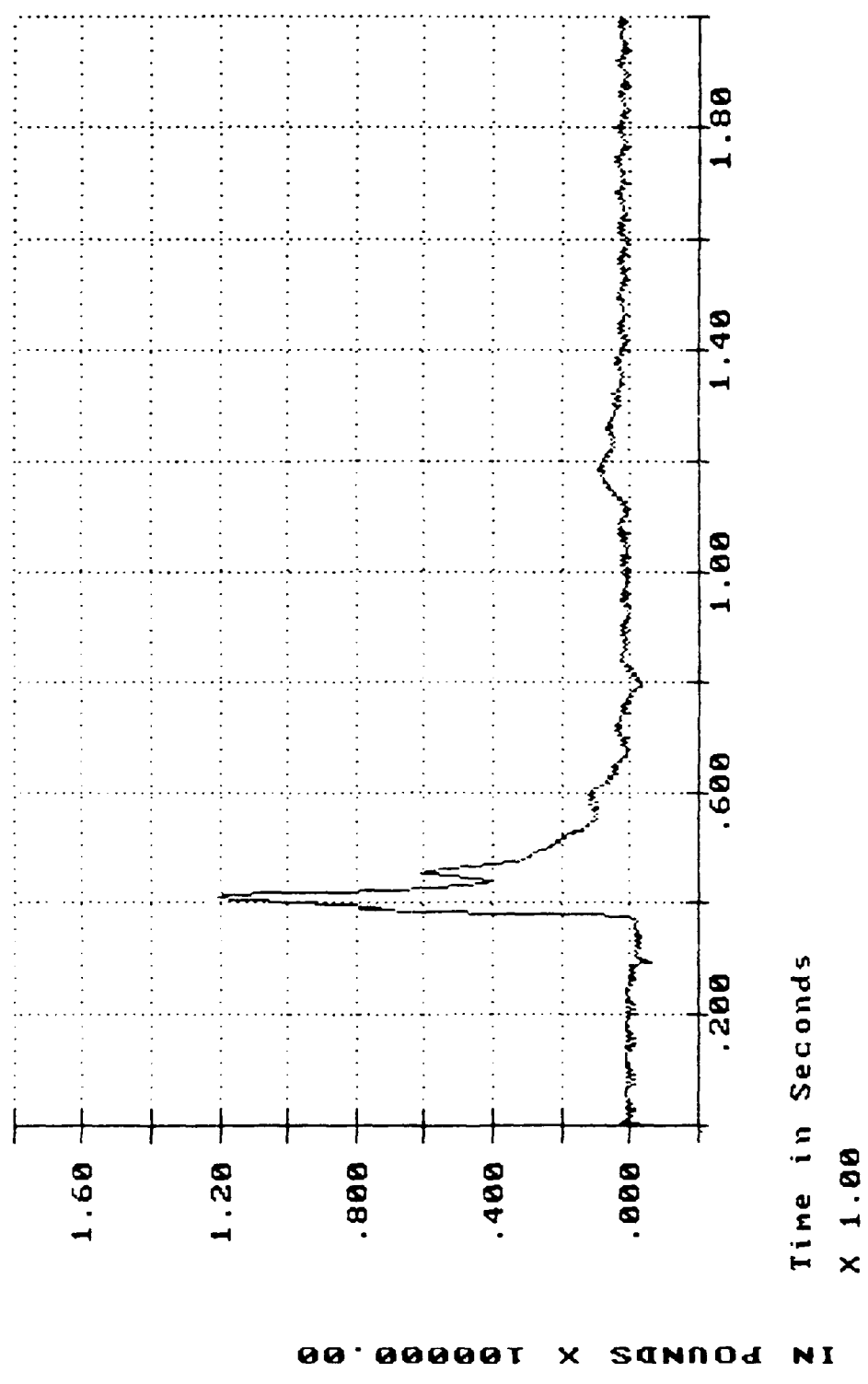

RAIL IMPACT TEST OF MARINE CORPS HALF-HEIGHT CONTAINER
IMPACT 2: 6.51 MPH, DATE: 23 MAY 1989

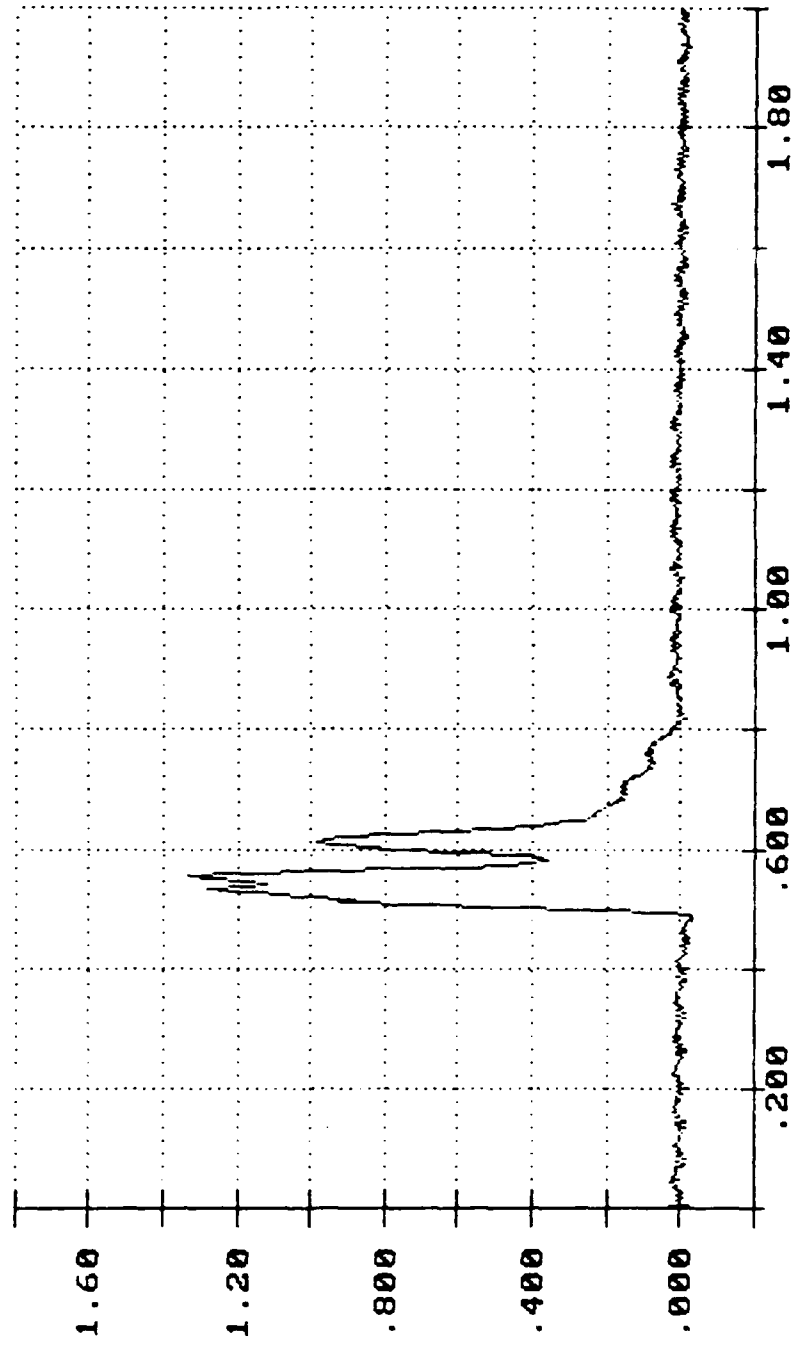

Time in Seconds
X 1.00

RAIL COUPLER FORCE
4-5 IN POUNDS X 100000.00

RAIL IMPACT TEST OF MARINE CORPS HALF-HEIGHT CONTAINER
IMPACT 3: 8.65 MPH, DATE: 23 MAY 1989

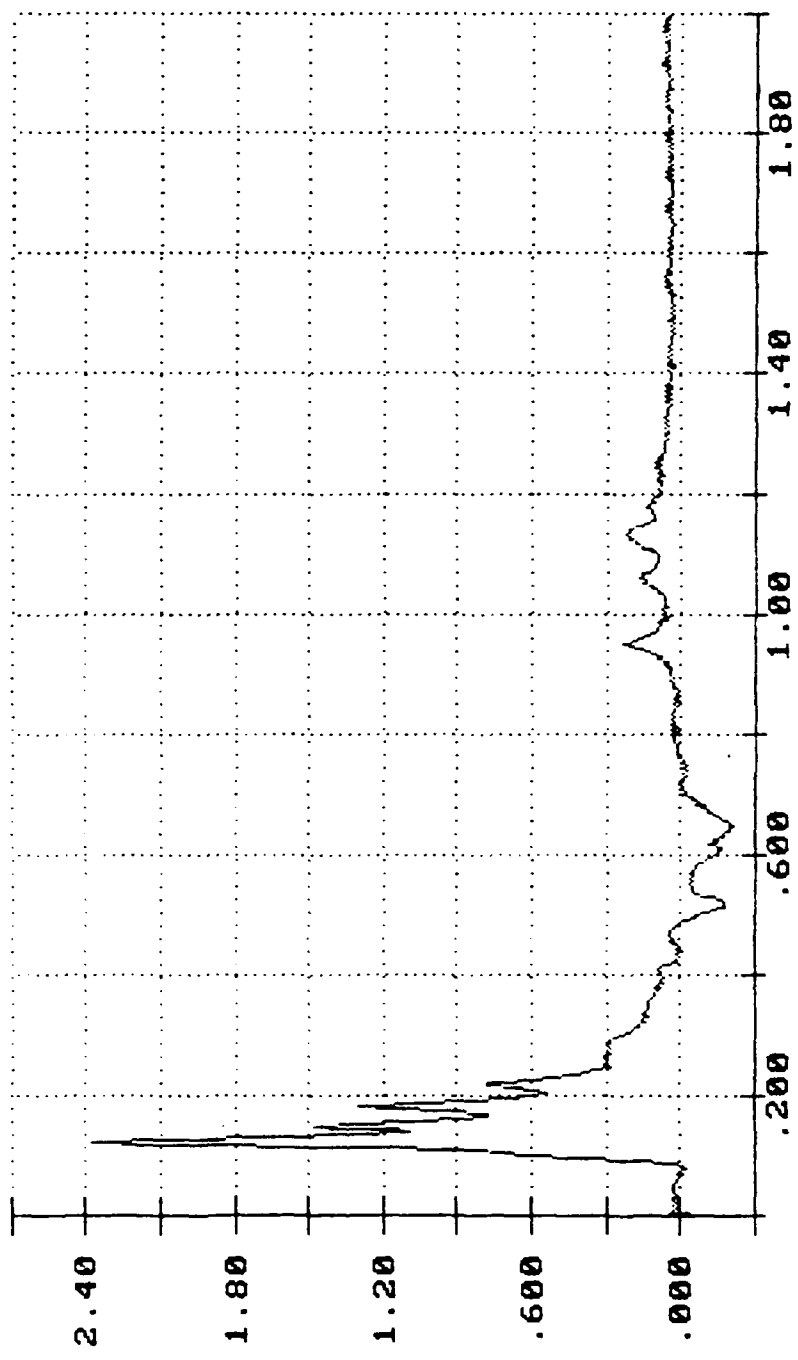

Time in Seconds
X 1.00

RAIL COUPLER FORCE
-9-
IN POUNDS X 100000.00

RAIL IMPACT TEST OF MARINE CORPS HALF-HEIGHT CONTAINER

IMPACT 4: 8.81 MPH, DATE: 23 MAY 1989

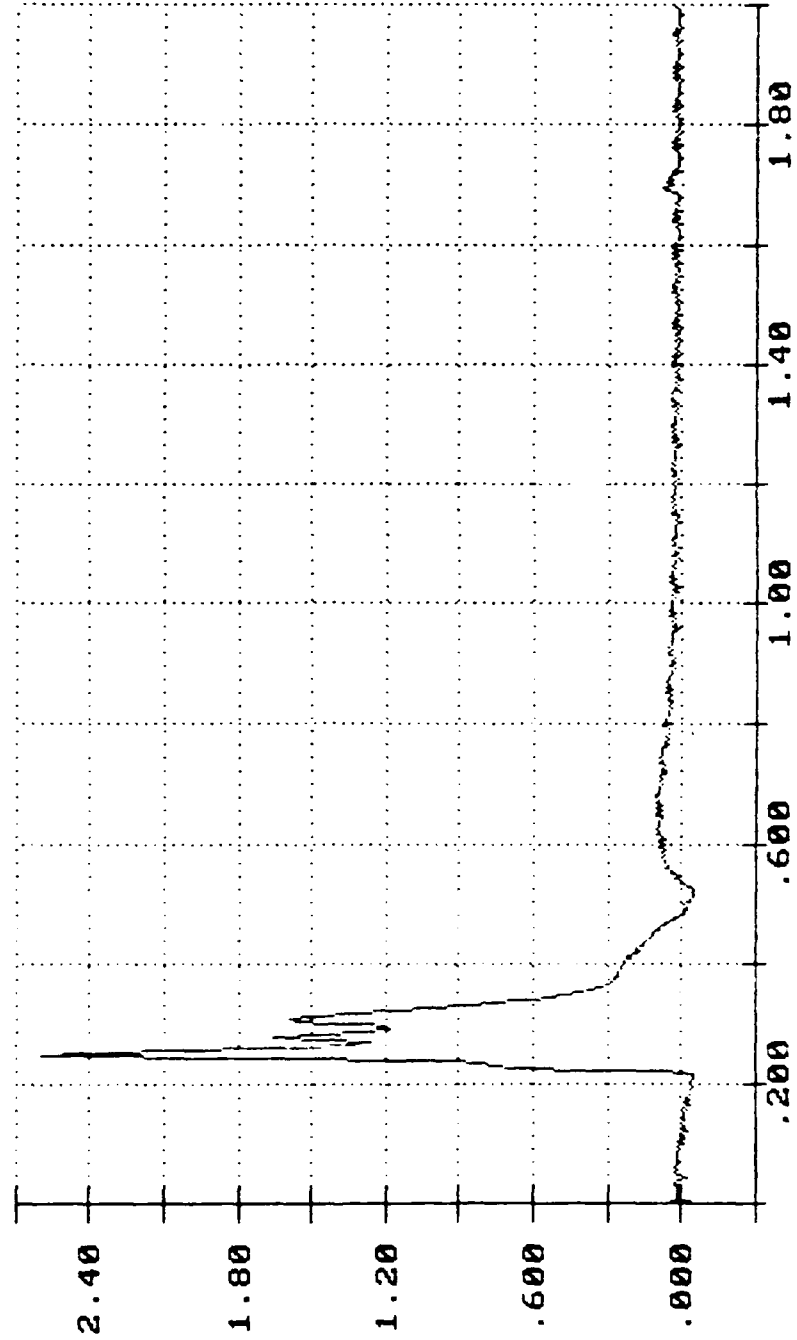

Time in Seconds

X 1.00

IN POUNDS X 10000.00

RAIL COUPLER FORCE

ROAD TEST DATA

TEST NO. 2

DATE: 23 MAY 1989

TEST SPECIMEN: Half-High ISO Container

PASS 1-A OVER FIRST SERIES OF TIES: 0.10 MIN 5.68 MPH

PASS 1-B OVER SECOND SERIES OF TIES: 0.10 MIN 5.68 MPH

REMARKS: No movement or damage to load

PASS 2-A OVER FIRST SERIES OF TIES: 0.10 MIN 5.68 MPH

PASS 2-B OVER SECOND SERIES OF TIES: 0.10 MIN 5.68 MPH

REMARKS: No movement or damage to load.

30 MILE ROAD TEST: No damage to load.

PANIC STOP TEST: No damage or load movement.

PASS 3-A OVER FIRST SERIES OF TIES: 0.10 MIN 5.68 MPH

PASS 3-B OVER SECOND SERIES OF TIES: 0.11 MIN 5.16 MPH

REMARKS: No damage to load.

PASS 4-A OVER FIRST SERIES OF TIES: 0.10 MIN 5.68 MPH

PASS 4-B OVER SECOND SERIES OF TIES: 0.095 MIN 6.00 MPH

REMARKS: No damage to load.

WASHBOARD COURSE: No damage to load.

SHIPBOARD TRANSPORTATION SIMULATOR: No damage to load or container.

PART 5
TEST PLANS

PROPOSED LOADING AND BRACING PROCEDURES
FOR 155MM SEPARATE LOADING PROJECTILES
(TALL UNIT) IN MARINE CORPS HALF HIGH
OPEN TOP INTERMODAL FREIGHT CONTAINER

INDEX

<u>ITEM</u>	<u>PAGE</u> (S)
GENERAL NOTES, AND MATERIAL SPECIFICATIONS -----	2
PALLET UNIT DETAILS -----	3
TYPICAL FULL LOAD PROCEDURES -----	4-5
GENERAL DETAILS -----	6-8

NOTE: This 8 page document delineates proposed outloading procedures to be used for the shipment of palletized units of 155MM separate loading projectiles (tall unit) in a Marine Corps half high open top container. The procedures as delineated are to be verified by rail impact, road transportability, and shipboard simulation tests prior to their approval for actual shipment.

Prepared during May 1989 by:

U.S. Army Defense Ammunition
Center and School
ATTN: SMCAC-DEO
Savanna, IL 61074-9639

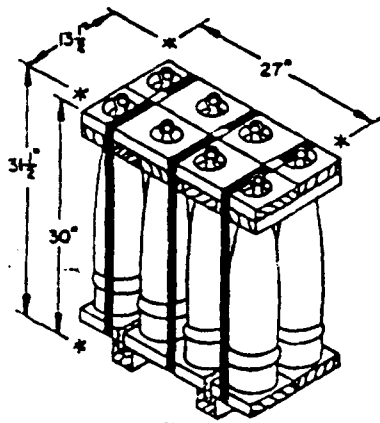

155MM, 8/PALLET (PALLET UNIT 1)

UNIT WEIGHT _____ 800 LBS (APPROX)
 CUBE _____ 6.6 CU FT

test unit

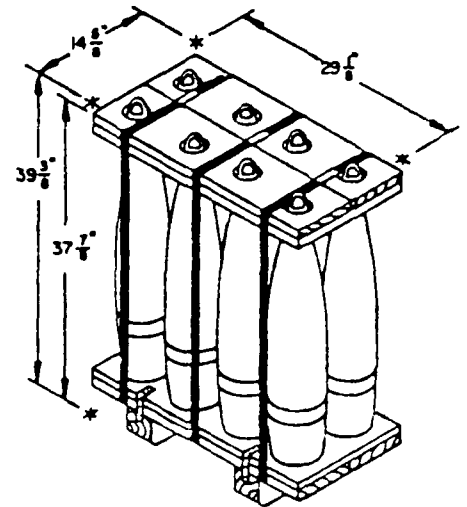

155MM, 8/PALLET (PALLET UNIT 2)

UNIT WEIGHT _____ 871 LBS (APPROX)
 CUBE _____ 9.7 CU FT

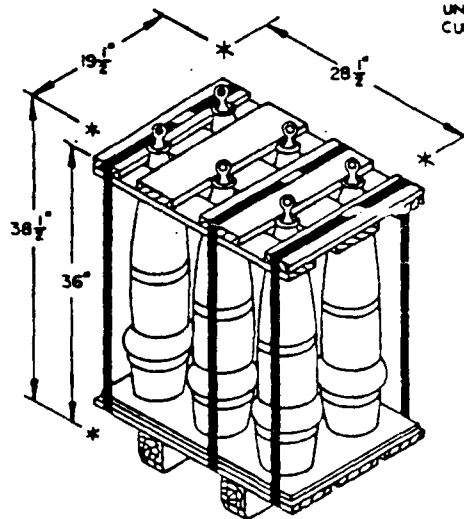

8" 6/PALLET (PALLET UNIT 3)

UNIT WEIGHT _____ 1,256 LBS (APPROX)
 CUBE _____ 12.4 CU FT

PALLET UNIT DETAILS

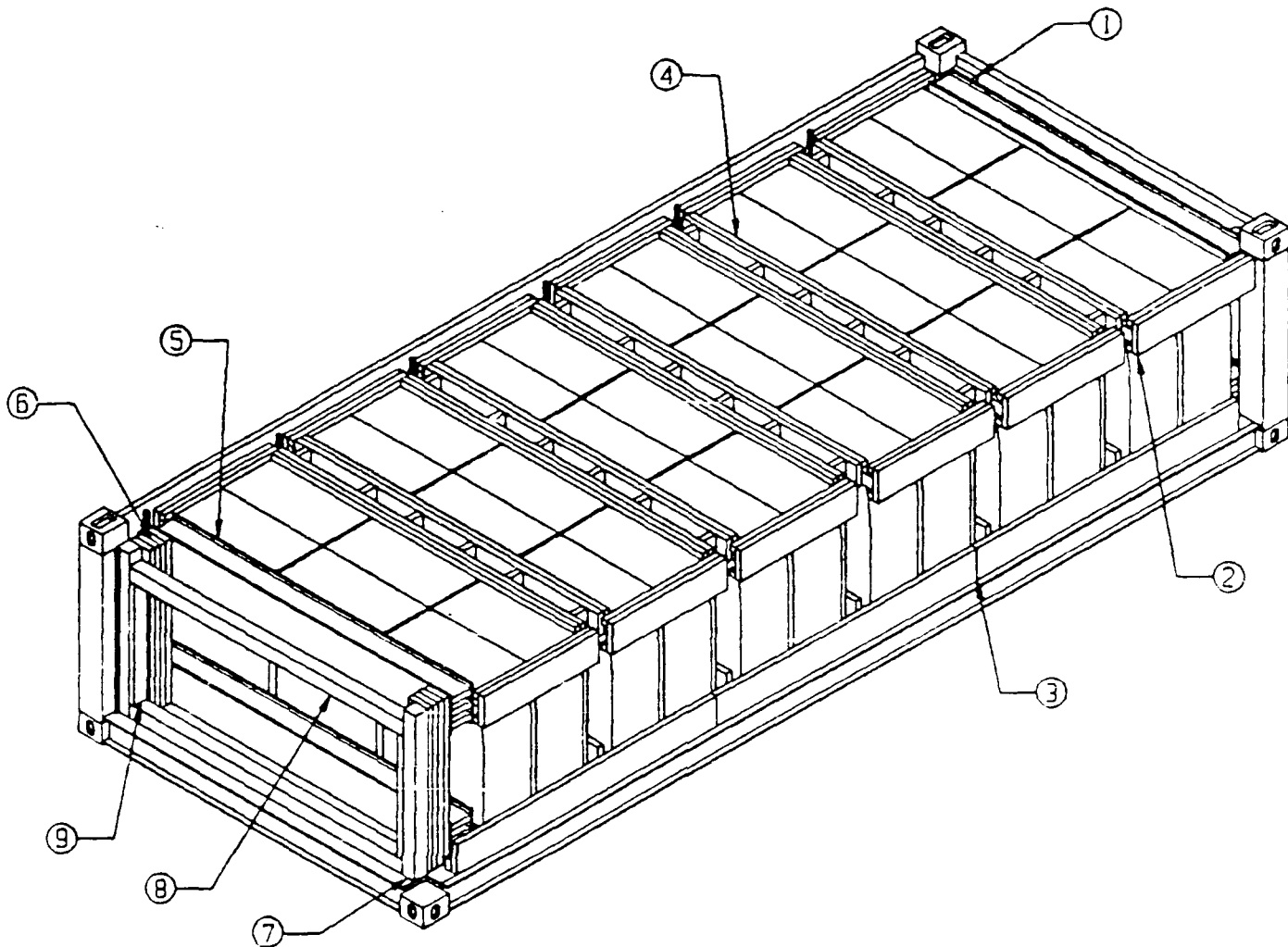

KEY NUMBERS

- ① FORWARD BLOCKING ASSEMBLY (1 REQD). SEE THE "FORWARD BLOCKING ASSEMBLY" DETAIL ON PAGE 6.
- ② UPPER SIDE FILL ASSEMBLY (12 REQD). SEE THE "UPPER SIDE FILL ASSEMBLY" DETAIL ON PAGE 7.
- ③ LOWER SIDE FILL ASSEMBLY (6 REQD). SEE THE "LOWER SIDE FILL ASSEMBLY" DETAIL ON PAGE 7.
- ④ SPACER ASSEMBLY (5 REQD). SEE THE "SPACER ASSEMBLY" DETAIL ON PAGE 8.
- ⑤ REAR BLOCKING ASSEMBLY (1 REQD). SEE THE "REAR BLOCKING ASSEMBLY" DETAIL ON PAGE 6.
- ⑥ FILLER PIECE, 2" x 6" x 40" (AS REQD). LAMINATE THE FIRST PIECE TO THE VERTICAL PIECE OF THE REAR BLOCKING ASSEMBLY $\frac{1}{4}$ -10d NAILS. LAMINATE EACH ADDITIONAL PIECE TO THE PREVIOUS IN A LIKE MANNER.
- ⑦ DOOR POST VERTICAL, 4" x 4" x 40" (2 REQD).
- ⑧ SPANNER PIECE, 4" x 4" BY CUT-TO-FIT (REF: 76-1/8") (2 REQD). TOENAIL EACH END TO THE DOOR POST VERTICAL $\frac{1}{2}$ -12d NAILS.
- ⑨ SUPPORT PIECE, 2" x 4" x 30" (2 REQD). NAIL TO THE DOOR POST VERTICAL $\frac{1}{4}$ -10d NAILS.

BILL OF MATERIAL

LUMBER	LINEAR FEET	BOARD FEET
2" X 2"	154	52
2" X 3"	56	28
2" X 4"	5	4
2" X 6"	163	163
2" X 8"	138	184
4" X 4"	19	26
NAILS	NO. REQD	POUNDS
6d (2")	180	1
10d (3")	588	9
12d (3-1/4")	8	1/4
1/2" PLYWOOD	46.6 SQ FT	64.1 LBS

LOAD AS SHOWN

<u>ITEM</u>	<u>QUANTITY</u>	<u>WEIGHT (APPROX)</u>
PALLET UNITS	36 ● 871 LBS	31,356 LBS
DUNNAGE		989 LBS
CONTAINER		4,760 LBS
TOTAL WEIGHT		37,105 LBS

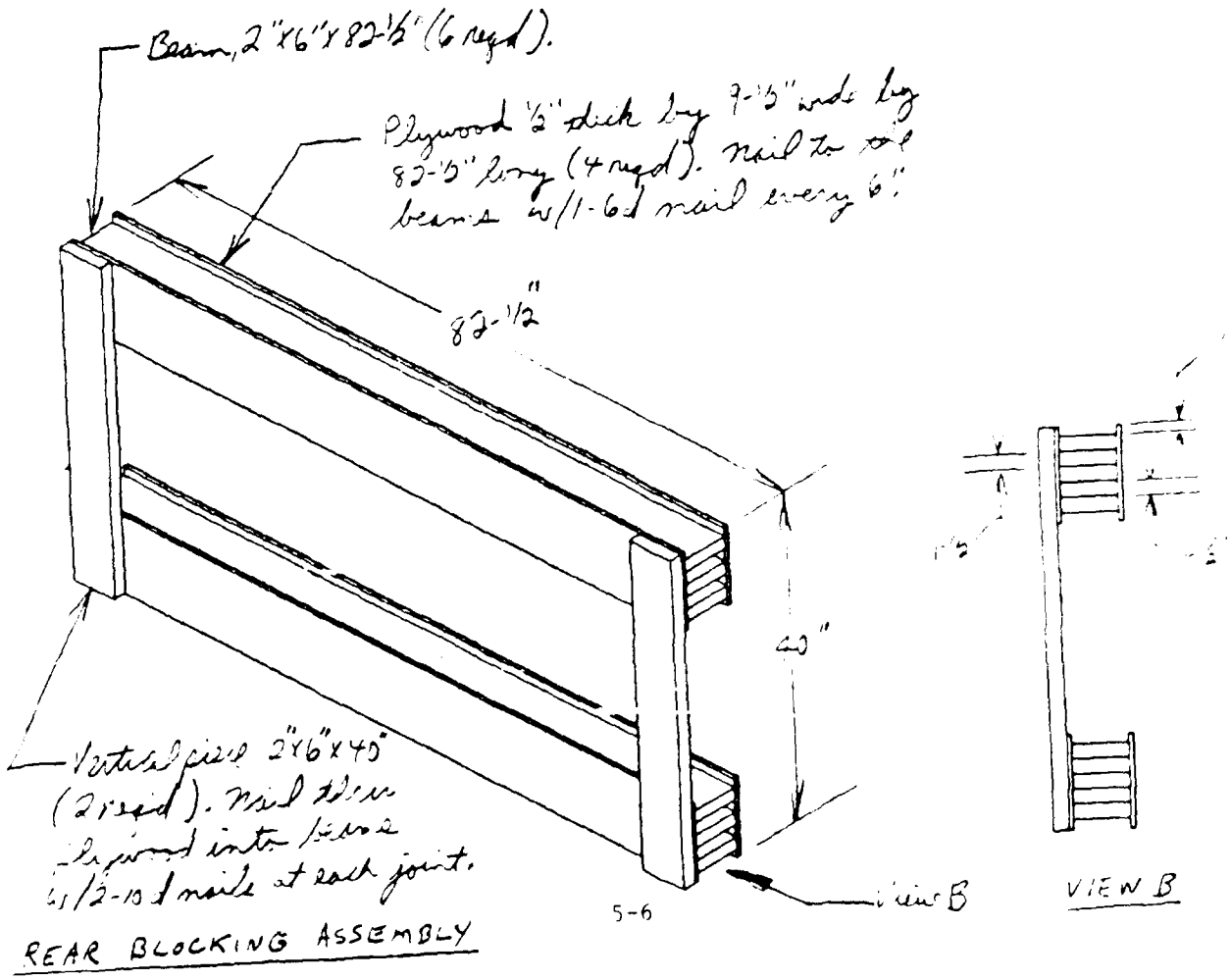
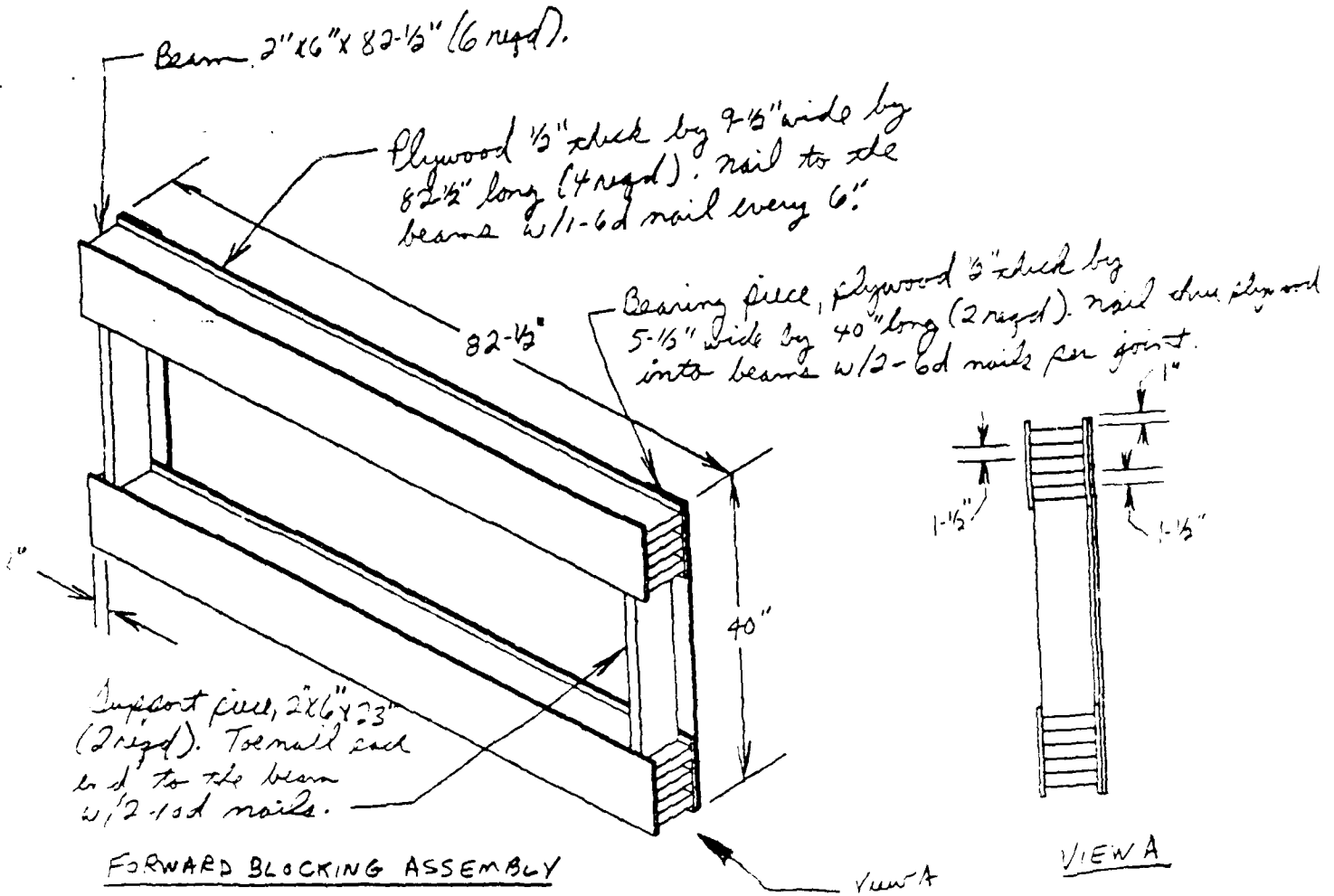

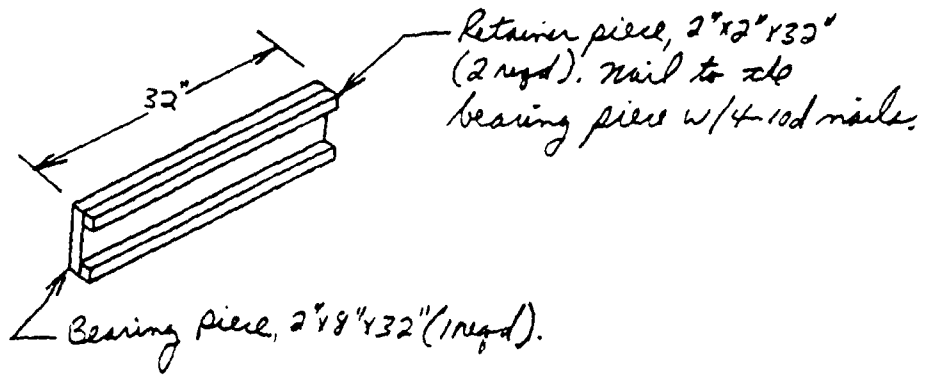

UPPER SIDE FILL ASSEMBLY

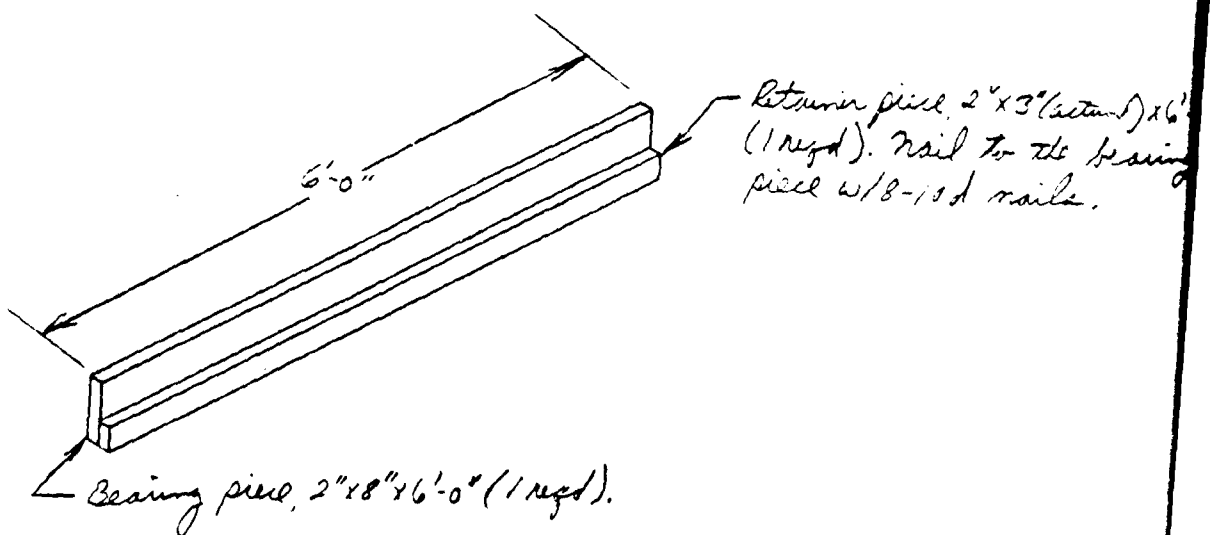

LOWER SIDE FILL ASSEMBLY

Upper bearing piece
 1" x 6" x 7'-0" (2 reqd).
 Nail to the spacer
 piece w/ 2-10d nails
 at each joint.

Lower bearing piece
 2" x 8" x 7'-0" (2 reqd).
 Nail to the spacer
 piece w/ 2-10d nails
 at each joint.

Spacer piece, 2" x 4" x 40" (6 reqd)

Upper retainer piece,
 2" x 2" x 7'-0" (2 reqd).
 Nail to the upper
 bearing piece w/ 8-10d
 nails.

Lower retainer piece, 2" x 3" (actual) x 8"
 (6 reqd). Nail to the lower bearing
 piece w/ 2-10d nails.

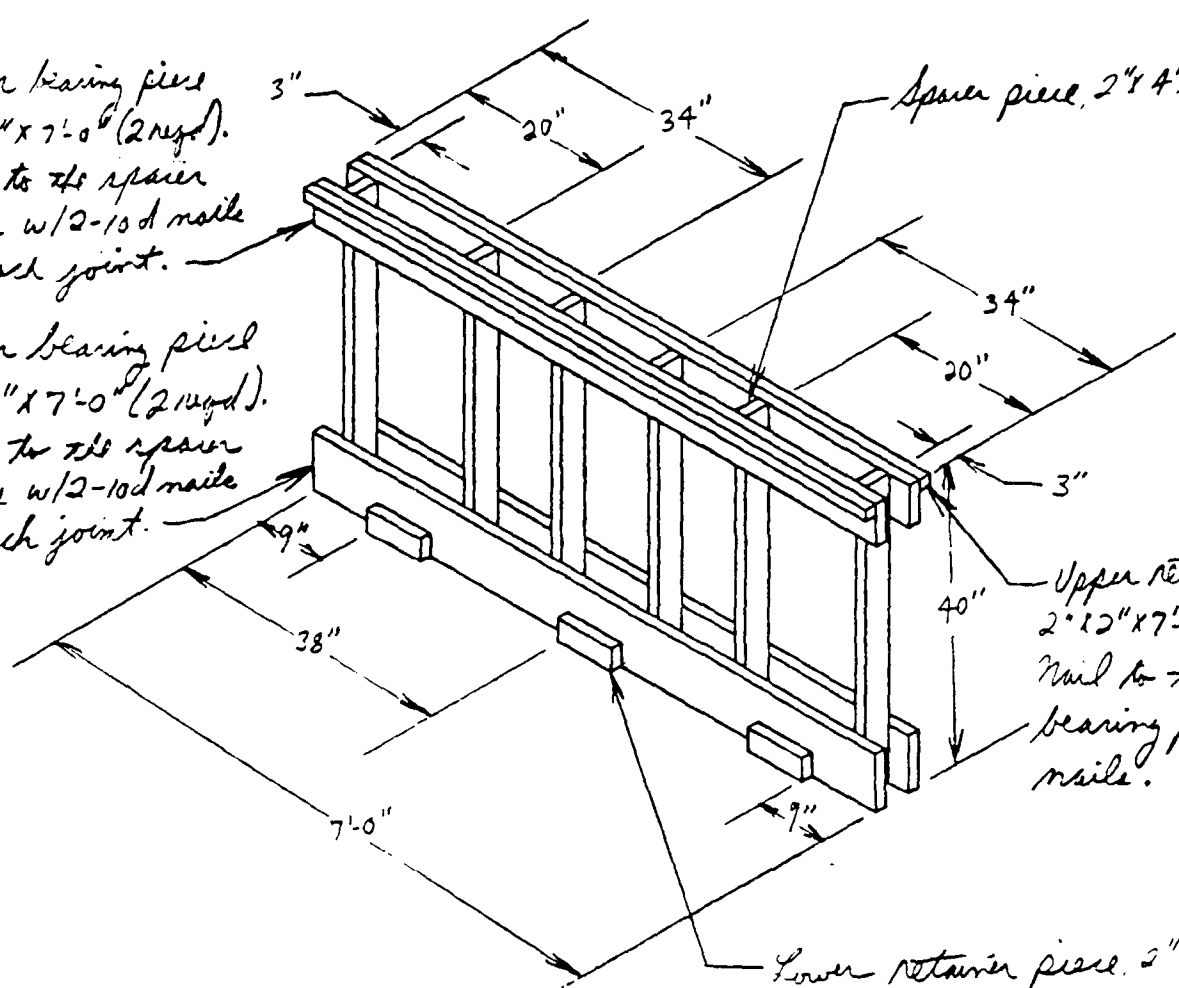

SPACER ASSEMBLY



CARGO CONTAINER PRODUCTION CERTIFICATE

18'-8" between faces of
corner posts (224")
40-1/2" internal height
cleaned w/ roof base

Design Type Number: AB/ 080 / 88

Certificate No. 88 LS 164-X

This certificate is for Thirty (30) Containers

Date 29th July, 1988

manufactured during July 1988

THIS IS TO CERTIFY that Thirty (30) Open Top with Tarp Containers

built by METALSINES-COMPANHIA DE VAGÕES DE SINES, SA - PORTUGAL

for MARTEC INTERNATIONAL TRADING CORPORATION, U.S.A.

have been thoroughly inspected at each stage of manufacture by ~~the attending Surveyor~~ ^{the attending Surveyor} ~~the Bureau of Shipping~~ ^{the Bureau of Shipping} and the details of design, materials, construction and workmanship of the containers conform to the applicable specifications and to the American Bureau of Shipping Rules For Certification of Cargo Containers.

The container(s) are constructed in accordance with prints reviewed on 7th April, 1988

reference T-3/9264; under general arrangement drawing 1-605-00-000; the prototype of which has

serial number MO2-2P-S1-001; was tested on 13 March 88 and 24 Jun 88, and subsequent dates:

and accepted with the issuing of prototype test certificates 88P 14269-X and 88 LR 153-X

Size 20' x 8' x 4'3"

Model OPEN TOP WITH TIR TARPAULIN AND RAMP

Max. Gross Wt.	20 320 kg	Tare Wt.	2 160 kg	Payload	18 160 kg
	44 797 lb		4 762 lb		40 035 lb

Manufacturers serial numbers: MO2-2P-S1-085 through MO2-2P-S1-114
through
through

Operating numbers: US MC 000 962-0 through US MC 000973-9
(with alpha prefix) US MC 000 974-4 through - -
US MC 000 976-5 through US MC 000992-9

Quality Control Superintendent

The undersigned has visited the plant of METALSINES
located at SINES, PORTUGAL
and carried out quality control surveillance as indicated in the Rules For Certification of Cargo Containers.

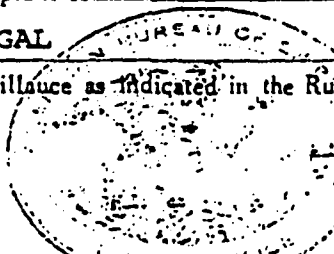

A. SALGADO Surveyor
American Bureau of Shipping

This certificate evidences compliance with the applicable Rules or other criteria of the American Bureau of Shipping and is issued solely for the use of the Bureau, its committees, its clients or other authorized entities. The certificate is a representation only that the containers have met the applicable Rules of the American Bureau of Shipping. The validity, applicability and interpretation of this certificate is governed by the Rules and standards of the American Bureau of Shipping who shall remain the sole judge thereof. Nothing contained in this certificate or in any report issued in contemplation of this certificate shall be deemed to relieve any designer, builder, owner, manufacturer, seller, supplier, repairer, operator or other entity of any warranty expressed or implied.

INTERNATIONAL CONVENTION FOR SAFE CONTAINERS (CSC)

THIS IS TO CERTIFY that the Containers identified on the obverse of this certificate meet the requirements of the International Convention for Safe Containers and the regulations promulgated by the United States Department of Transportation. The containers are hereby approved and the applicant may affix, to every container noted hereon, a Safety Approval Plate with Approval number:

USA/AB— 080 / 88

A. SALGADO Surveyor 

The containers identified on the obverse of this certificate carry an International Convention for Safe Container approval plate bearing the number _____

CUSTOMS CERTIFICATION (TIR)

THIS IS TO CERTIFY that the undersigned has visited the plant of the manufacturer to examine random containers from the group identified on the obverse of this certificate for adherence to the certificate of approval by design type for transport of goods under customs seal and found such containers in compliance.

Design Type Approval Certificate Number: USA/ —AB/

Surveyor

THIS IS TO CERTIFY that each of the containers identified on the obverse of this certificate have been manufactured in full compliance with the applicable certificate of approval by design type.

Quality Control Superintendent

The containers identified on the obverse of this certificate carry a Customs approval plate bearing the number P/DGV-019/88

INTERNATIONAL UNION OF RAILWAYS (UIC)

THIS IS TO CERTIFY that the containers identified on the obverse of this certificate have been constructed in accordance with approved drawings and are in compliance with UIC Code 592-1 OR.

The containers conform to the prototype of the design series; were tested to UIC Requirements; and are as represented on prints _____ These containers are to be registered with _____ and bear the participating railway code number _____

Surveyor

The containers identified on the obverse of this certificate are marked with UIC railway code number IC 94

WOOD TREATMENT

The exposed timber of the containers identified on the obverse of this certificate has been treated in accordance with the Australian Department of Health Regulations as set forth in "Cargo Containers and Unit Loads — Quarantine Aspects and Procedures."

Quality Control Superintendent

Treatment _____