

1.3

1.32

1.36

1.4



AD-A215 620

2

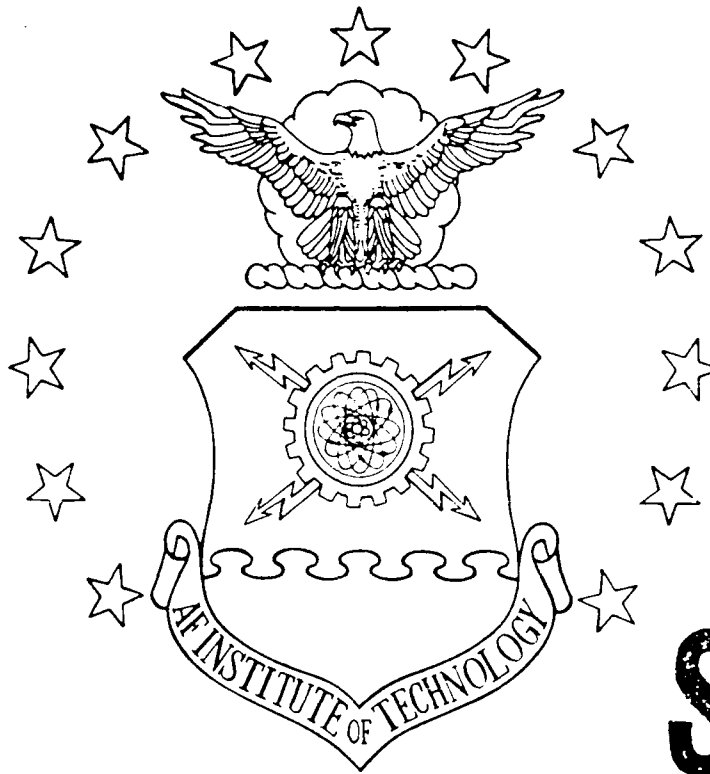

DTIC FILE COPY

DTIC
 ELECTE
 DEC 20 1989
 S D
 Day

DESIGN CHANGE NOTICES
 IN AIR FORCE SPARES ACQUISITION
 THESIS
 Joseph W. Burns
 AFIT/GLM/LSM/89S-5

DISTRIBUTION STATEMENT A

Approved for public release.
Distribution Unlimited

DEPARTMENT OF THE AIR FORCE
AIR UNIVERSITY

AIR FORCE INSTITUTE OF TECHNOLOGY

Wright-Patterson Air Force Base, Ohio

89 12 19 034

2

AFIT/GLM/LSM/89S-5

DTIC
ELECTE
DEC 20 1989
S D D

DESIGN CHANGE NOTICES
IN AIR FORCE SPARES ACQUISITION
THESIS

Joseph W. Burns

AFIT/GLM/LSM/89S-5

Approved for public release; distribution unlimited

The contents of the document are technically accurate, and no sensitive items, detrimental ideas, or deleterious information is contained therein. Furthermore, the views expressed in the document are those of the author and do not necessarily reflect the views of the School of Systems and Logistics, the Air University, the United States Air Force, or the Department of Defense.

Approved For	
NTIS	<input checked="" type="checkbox"/>
DTIC TAB	<input type="checkbox"/>
Unannounced	<input type="checkbox"/>
Justification	
By	
Distribution	
Availability Codes	
Dist	
A-1	

AFIT/GLM/LSM/89S-5

DESIGN CHANGE NOTICES
IN AIR FORCE SPARES ACQUISITION

THESIS

Presented to the Faculty of the School of Systems and
Logistics of the Air Force Institute of Technology
Air University
In Partial Fulfillment of the
Requirements for the Degree of
Master of Science in Logistics Management

Joseph W. Burns

September 1989

Approved for public release; distribution unlimited

Preface

This research describes Design Change Notices (DCN) and DCN processing in the Air Force to determine whether process improvements are possible and suggests alternative processes. A flow chart of the DCN process was developed and information about the different quantities and types of DCNs submitted was gathered.

I am indebted to many people for their help in the development of this thesis. The WR-ALC DCN process participants took time out from their hectic schedules to provide valuable information and insights. The HQ AFLC Provisioning Policy DCN Process Action Team members worked with me throughout this research, providing many good ideas and gently discouraging bad ones. I thank them all.

I want to express a special thanks to Mr Tom Watts who went out of his way, despite his own considerable workload, to provide advice and technical assistance from beginning to end. I also thank my advisor, Charles F. Youther, for his advice and patience, and especially, for his enthusiasm.

Finally, I thank my wife Rose, and my children Tyler, and Samantha. Rose for her love, encouragement, and support; and all three for helping me to smile and keep it all in perspective.

Table of Contents

	Page
Preface	ii
List of Figures	v
List of Tables	v
Abstract	vi
I. Introduction	1
General Issue	1
Problem Statement	3
Investigative Questions	4
Scope of the Research	4
Justification	5
Assumptions	6
II. Review of the Literature	7
Introduction	7
DCN Description	9
MIL-STD-1561B.	9
MIL-STD-1388-2A.	10
AFLCR 800-9.	12
AFLCM 65-33.	13
Air Force Addendum.	15
Summary	16
III. Methodology	17
Introduction	17
The Process Phase	18
Interviews.	18
Other ALC Inputs.	18
The Data Phase	19
The G064.	19
The Population.	20
Quantities of DCNs Versus Original Data.	21
Types of DCNs.	21
By TOCC.	21
ACNs Versus DCNs.	21
Procurable Versus Non-procurable.	22
Analysis	23
IV. Findings and Analysis	24
Introduction	24
The Process Phase	24
Stage 1.	26
Stage 2.	27
Stage 3.	28

	Page
Depot Team.	31
Stage 4.	31
Stage 5.	32
The Data Phase	33
Quantities of DCNs Versus Original Data.	33
By TOCC.	36
Additional Item.	36
Deleted item.	36
Modified Item.	37
Quantity Decrease.	37
Limited Application.	37
Typographical Error.	38
Quantity Increase.	38
ACNs Versus DCNs.	40
Procurable Versus Non-procurable.	43
V. Conclusions and Recommendations	45
Introduction	45
The Process Phase	45
The Data Phase	46
Quantity Versus Initial Submission.	47
By TOCC.	48
ACNs versus DCNs.	50
Procurable Versus Non-procurable.	54
General Discussion.	55
Summary	56
Bibliography	58
Vita	60

List of Figures

Figure	Page
1. DCN Process Flow	25
2. Quantities of DCNs per 100 Original Items.	35
3. Percentages of Types of Changes, WR-ALC.	39
4. Traditionally Identified ACNs	42
5. Not Traditionally Identified ACNs	42
6. LANTIRN Non-procurable DCNs.	44

List of Tables

Table	Page
1. Type of Change Codes	ii
2. ACN Decision Rules Table	53

Abstract

A new Air Force weapon system, if delivered before the support items needed to sustain its use, is not a credible threat or deterrent. To ensure concurrent delivery of support items and the end item, provisioning data, used to initiate procurement of the support items, is processed long before production of the end item is completed. Due largely to the complexity of new Air Force systems, changes to the design frequently occur after the original provisioning data is submitted. Design Change Notices (DCN) are used to notify the Air Force of changes that have occurred to the provisioning data. The volume of changes being submitted threatens to overwhelm the Air Force provisioning process and obviate the advantage of processing the data early to begin with.

This research describes DCNs and DCN processing in the Air Force. A flow chart of the current DCN process illustrates that the process is repetitive and inefficient, but the process is inextricably linked to the Air Force provisioning data system. A new data system must be developed to solve the process inefficiencies. In addition, many DCNs that are being submitted and processed do not impact support item procurement. These must be identified and edited out rather than be processed unnecessarily.

DESIGN CHANGE NOTICES IN AIR FORCE SPARES ACQUISITION

I. Introduction

General Issue

United States military strategy emphasizes technological superiority over numerical superiority. The reasoning goes that a relative few technologically advanced weapon systems will be able to overwhelm many technologically inferior systems. An inherent risk in this approach is that a single failure in a system that is planned to counter say, twenty systems, is the equivalent of twenty system failures for the other side. Weapon system support, maintenance, spares, and support equipment is especially critical in a technological superiority strategy.

Provisioning is defined as "the management process of determining and acquiring the range and quantity of support items necessary to operate and maintain an end item of materiel for an initial period of service (4:4)." Any new system of even moderate complexity will soon be useless unless the support items, primarily spare and repair parts and test equipment, that it needs are available. To claim that a new system is finally operational then, it is necessary to obtain not only the prime mission equipment, the end item, but also a complement of the support items

that are necessary to operate and maintain it.

In determining what specific support items and quantities are sufficient for a given system, the Air Force uses provisioning data which are normally supplied by the prime contractor. Each part in a system is described in this provisioning data in terms of, among other things, its probable failure rate, the way it will be repaired, and its place in the system's hierarchy of parts. Also included in the provisioning data are any tools, test equipment, or other sundry items required to operate, service, or repair the end item (5:5).

An Air Force technical staff reviews the data, ultimately recommends buy quantities for every item that will be required, and starts the procurement process that will eventually place each item in the quantities needed in the Air Force supply system (10:1: 8:11, 53-55). All this must be accomplished before successful fielding of the new system can occur. The process is time consuming and must be started early enough in the acquisition schedule of the end item that it can be completed by the time the end item is operational. It must at the same time be started late enough that the end item is sufficiently design stable. Naturally, if the design of the end item changes, the support items it requires will change as well. When that happens after provisioning has begun, some new and different

items will have to be procured and some items already being procured will have to be withdrawn from procurement.

Due largely to the complexity of new Air Force systems, some changes to the design frequently do occur after the provisioning process has begun. Design change notices (DCNs) are used to notify the government of changes that have occurred to provisioning data which add to, delete, supersede or modify items that have already been submitted by the contractor (5:13). Large numbers of changes are costly both in the expense of their preparation by the contractor and in the expense of their subsequent processing by government personnel. More importantly, these changes interfere with and delay the acquisition process, adversely affecting initial and subsequent operational capability of the end item by reducing the support capability available for its effective use.

Problem Statement

Large numbers of DCNs do occur during the development and acquisition of Air Force weapon systems. Provisioning policy on DCNs is not specific about processing procedures and governing regulations are not always in agreement. While the fact that every weapon system is different both in terms of equipment type and provisioning strategy suggests that the numbers and types of DCNs will be program specific, even the average quantities and types of DCNs being

submitted are unknown.

This study describes DCNs and current DCN processing in the Air Force to determine whether improvements are possible and suggests alternative processes.

Investigative Questions

To accomplish the objectives of this research, the following detailed questions were asked:

1. What is the DCN process?
2. Who are the players in the process and what are their individual requirements for the data?
3. How many and what types of DCNs are processed relative to the total number of line items?
4. How much variation in the types and numbers of DCNs exists among different contracts?

Scope of the Research

The bulk of Air Force weapon system management, including provisioning, is divided between five geographically separate Air Logistics Centers (ALCs). The responsibility for Air Force provisioning policy resides at the Air Force Logistics Command (AFLC) headquarters at Wright-Patterson Air Force Base, Ohio, but the specific processes by which that policy is implemented may vary dramatically between the five ALCs.

DCN process research was concentrated on provisioning at Warner Robins Air Logistics Center (WR-ALC), Georgia. The other four centers were solicited for input on their

procedures with regard to DCNs and these were also incorporated. Some support items that are not specific to a given WR-ALC program are not managed there, and part of their processing occurs at other locations. The off-base processing of these items is not a subject of this research.

DCN data examined were limited to data from programs that are assigned to WR-ALC. Data were drawn from provisioning contracts in the following three groupings: 1) an aggregate of all contracts within the WR-ALC provisioning database, 2) a small group of twelve completed contracts, and 3) contracts associated with the Low Altitude Navigation and Targeting Infrared System for Night (LANTIRN) program.

Justification

General Alfred G. Hansen, the AFLC commander, has emphasized the importance of quality in Logistics processes. Process Action Teams (PAT) have been organized throughout the command to improve process quality. The PAT is made up of personnel who are involved in different aspects of a given process. AFLC, through the Provisioning Policy Branch of the Directorate of Materiel Policy, requested that a study of DCNs be done in coordination with the efforts of two DCN PATs currently operating within AFLC. The results of this study together with the findings of the two PATs will be used to evaluate current provisioning policy concerning DCNs and will serve as a reference for the

rewrite of the DCN portion of the Air Force Provisioning Policies and Procedures regulation, AFLCR 800-9. Better guidance in AFLCR 800-9 is hoped to lead to reduced costs and increased readiness through more timely and efficient delivery of initial support.

Assumptions

This research is based on the following assumptions and limitations:

1) Completed programs in the aggregate are not significantly different than current and future programs in the aggregate, in terms of numbers and types of DCNs relative to each other and to the total number of line items.

2) Existing queries of the AFLC Management and Control of Provisioning System DSD G064 are valid (11:18; 15:1-6). The G064 is an interactive database that serves as an interface to the D220, the Air Force provisioning system.

3) Data are not segregated historically. DCN policy may vary even over the life of a single program, certainly over the aggregate of all programs to date. Therefore, data concerning a program represent the sum total of everything that has been submitted to date and do not necessarily reflect the latest provisioning policy.

II. Review of the Literature

Introduction

Virtually everyone involved with DCNs, at the plans and policy level as well as the working level, agrees that DCNs are a serious problem in Air Force acquisitions. According to the Information Resources Management Branch at Ogden ALC, "The processing of DCNs is probably the most difficult thing to do in the provisioning process, to say the least (16:1)."

In the fall of 1987 the approximate number of DCNs being processed at one time at each of the five ALCs ranged from 4,500 to 36,000 (13:2). The B-1B Strategic Bomber system probably set a record for a single program: over 187,000 DCNs submitted as of January 1988. A point of interest is that the United States General Accounting Office (GAO) mistakenly reported that 187,455 design changes had been submitted at that time; they were actually design change notices (12:30). This research will show that design changes and DCNs are two different things, and two DCNs are often submitted for only one design change. The consolation is small; the Air Force still processes them all. At the close of this research the number of DCNs on the B-1B had risen to over 228,000 and they are still coming in.

A function of the Headquarters AFLC Provisioning Policy Branch is to improve the provisioning processes, and the DCN problem is no exception. Their focus has been to emphasize

the segregation of DCNs into two categories, engineering-type change notices, and administrative-type change notices. This policy has been ill received in the field due to a lack of consensus that administrative-type changes occur in sufficient quantities to be worth the trouble, and a lack of understanding of what is to be gained if they are. The headquarters position is that administrative-type changes probably occur in significant numbers, are less important to provisioning than engineering-type changes, and may be handled separately, allowing the provisioning office to "make or not make the changes they deem appropriate (1:1)." Before this issue can be further addressed, two questions must be answered: what exactly is a DCN, and are administrative-type changes really different?

To address the first question, this review follows the description of DCNs through the hierarchy of governing regulations from Military Standard, through AFLC regulation, to AFLC Manual, and finally to the Air Force Addendum to the Military Standard. The emphasis of this drawn-out review of the definition of a DCN is to establish the difference between a notice due to an engineering change and a notice due to an administrative change and to explain why both are known as DCNs, thereby answering the second question.

DCN Description

MIL-STD-1561B. The Uniform Provisioning Procedures Standard for the Department of Defense, MIL-STD-1561B, provides the following definition for DCNs: "A design change notice is used to identify changes to Provisioning Technical Documentation (PTD) which add to, delete, supersede, or modify items previously listed which are approved for incorporation into the end item." It goes on to say that "The contractor shall notify the provisioning activity of all changes whether of a production or modification type which are approved for incorporation into the system/equipment furnished under the contract (5:13)."

The words design change; add to, delete, supersede, or modify items; and approved for incorporation into system/equipment are important. It is items that are being changed and not just data under this definition, and the items change because of a government approved change to the design of the system/equipment. This translates into a simplified working definition: DCNs identify changes to PTD resulting from approved changes to the design of the system/equipment. Corrections to data errors, about items that have not changed, having nothing to do with a change to the design, clearly do not fit, and are not DCNs under this definition. Indeed, a contractor requirement to notify the provisioning activity of error corrections is not addressed at all by this standard.

MIL-STD-1388-2A. MIL-STD-1561B is written to be compatible with MIL-STD-1388-2A and is to be used in conjunction with that document (5:iii,1). MIL-STD-1388-2A, DOD Requirements for a Logistic Support Analysis Record, does not specifically define DCNs so the MIL-STD-1561B definition applies. MIL-STD-1388-2A does acknowledge that errors and other types of changes will occur to provisioning data, and distinguishes them from DCNs. Under MIL-STD-1388-2A, provisioning data is reported in the LSA-036 Report. In Appendix B, 40.33.4, titled "LSA-036 Update and Design Change Notices," five types of updates are identified which can result when data is added, changed, or deleted affecting provisioning data previously delivered. The five updates are 1) Standard Data Update, 2) Quantity Data Update, 3) Key Data Update, 4) Associated Data Update, and 5) DCNs (3:236,237). The explanations for each of the five types of update are complicated, appear to be incomplete, and are certainly difficult to understand. They focus mainly on which data fields will need to be changed for each type of update. Not specified is the reason why each of the five types of updates might have occurred, only that changes had occurred. MIL-STD-1388-2A goes on to state that "DCN information is not distinguished from other updated data for a particular LSA-036 update (3:237)." So although at least some updates are not DCNs, it is impossible to tell whether a change was or was not a DCN once the update is made.

Recall the DCN working definition based on the definition in MIL-STD-1561B: DCNs identify changes to PTD resulting from approved changes to the design of the system/equipment. Some or all of the other four updates might also be the result of approved changes to the design. For example, a quantity change due to an approved design change seems to fit equally well into either the quantity data update or the DCN category. A quantity change to correct an error, however, would fit the quantity data update category but not the DCN category.

Also provided by MIL-STD-1388-2A are the Type of Change Codes (TOCC) used to segregate types of DCNs. The codes are listed in Table 1.

Table 1. Type of Change Codes

<u>TOCC</u>	<u>Explanation</u>
M	Modified item.
D	Deleted item.
T	Typographical error.
Q (or A)	Quantity adjustment.
L	Limited part application.
G	Deletion of data element.

Since the Air Force Provisioning System, D220, was designed around the old and now obsolete MIL-STD-1552A, changes are made by D220 to the original LSA-036 codes.

MIL-STD-1552A and consequently D220 does not recognize a G, deletion of data element (6:6). Air Force regulations reviewed do not explain what happens to a G TOCC when it enters the D220. It is assumed that a G TOCC is converted to M for modified item. In addition, D220 recognizes both a quantity increase and decrease so the Q becomes an A if the quantity actually increased and remains the same if the quantity decreased (7:6-2).

AFLCR 800-9. The Air Force Provisioning Policies and Procedures, AFLCR 800-9, is an Air Force regulation while the two military standards are DOD level. AFLCR 800-9 defines DCNs this way: "The DCN is the type of PTD used by the contractor to notify . . . the provisioning activity of all engineering changes . . . which are approved for incorporation into the end item on contract and which modify, add to, delete or supersede parts in the end item or its supporting equipment (8:57)." This definition is specific in stating that DCNs result from engineering changes that are approved. This detail, that approved changes are approved engineering changes, should prove to be an important and useful point since engineering changes proposals (ECP) are what are approved by the government to effect changes to the design, and they are well documented and carefully numbered (2:38-53). What AFLCR 800-9 does not do is identify or address changes to provisioning data due to other than approved engineering changes.

AFLCM 65-33. Any updates to the LSA-036 report are input directly into the AFLC Provisioning System, D220, as type of Provisioning Technical Documentation (PTD) "D" for Design Change Notice. AFLCM 65-33, the AFLC Provisioning System (D220) Users Manual, does recognize engineering changes and other than engineering changes. The former are identified as "Changes Resulting From DCNs" and the latter are identified as "Changes Not Resulting From DCNs." The shortened titles are DCNs and Change Actions (CA). Except for the different headings, the D220 output products are the same for either CAs or DCNs (7:6-11, 6-2). The differently titled products are processed through D220 in exactly the same way with the same processing times (7:5-21). Because both are submitted as "Design Change Notice," type PTD "D," and because no significant difference in processing is identified, both CAs and DCNs are widely known as DCNs.

According to AFLCM 65-33, D220 recognizes DCNs by an entry in the "engineering change authority" block on the D220 input tape. CAs, by default, are recognized by the lack of an entry in the engineering change authority block. It is this difference that the D220 system uses to separate and then title its output products (7:6-11). Whether the change authority field is an appropriate discriminator or not, it is the discriminator used by the D220.

More details are given in AFLCM 65-33 on differences between CAs and DCNs. These details appear to confuse the

issue, since the actual segregation is based on the change authority field. Under the heading "Type PTD" and subheading "D Design Change Notices" is the statement that, "an item received with a type PTD of 'D' and a TOCC 'D' delete, 'Q' quantity decrease, 'A' quantity increase, or 'L' limited, accompanied by an engineering change authority number shall be output as a 'Design Change Notice'." Of course the same is also true of the other TOCCs "M" and "T." Also stated is that "an item received with a type PTD of 'D' and a TOCC of 'T' typographical error shall be output as a 'Notice of Change Action' (7:6-2)." This is true, however, only if the Change Authority Block is blank in which case any other TOCC will produce a CA as well. A TOCC of M is not mentioned. Still elsewhere in the same chapter is the statement that CAs are indicated when the Change Authority field is not filled and portray quantity changes or corrections of typographical errors. These conditions correspond to TOCC Q or A, and T; left out are D, M and L, which also result in CAs if the Change Authority field is not filled. In the same paragraph it goes on to say that data elements that have been changed by the contractor independently will have a TOCC of T (7:6-12, 6-13). This is not necessarily true. TOCCs are assigned automatically by the field or fields that changed, not by the reason the field changed or on whose authority it was changed (3:180). It is unclear, how a TOCC of T could ever be automatically

assigned. A change of quantity from one to two could be due to typographical error, design change, or simple mistake.

Air Force Addendum. The MIL-STDs-1388-2A and 1561B Provisioning Requirements Statement Air Force Addendum, is uncomplicated. Under the heading "Design and Administrative change Notices," are the following "Categories": 1) "Design Changes which result from an approved Engineering Change Proposal (ECP), which require an entry in the Change Authority block," and 2) "Non-ECP changes resulting from omission or correction of data submitted by the contractor. These changes are considered Administrative Change Notices (ACNs). The Change Authority block . . . will be blank (9:2)." ACNs from the Air Force Addendum, correspond directly to CAs from AFLCM 65-33; the Change Authority block is blank. The Air Force Addendum goes on to say that two different methods for submittal are allowed for ACNs. They may be submitted just as any other update, with the extra requirement that the reason for the change be provided in a remarks block; and, if authorized by the ALC provisioning section, they may be submitted by message describing the changes to be made. How the information in the message is to be processed is not addressed. Headquarters AFLC Provisioning Policy does state that, for ACNs submitted by message, the provisioning office is "responsible to make or not make the changes they deem appropriate. (1:1)." .

Summary

What is commonly referred to as DCNs actually includes two different kinds of changes, DCNs and ACNs. DCNs result from a change to the design and ACNs, sometimes referred to as CAs, result from something other than a change to the design, specifically omissions or corrections. All of the regulations reviewed showed that DCNs were different than ACNs, although MIL-STD-1561B failed to recognize that ACNs exist. The change authority block was identified in AFICM 65-33 and the Air Force Addendum as being the sole discriminator between ACNs and DCNs, although MIL-STD-1388-2A stated that DCNs could not be distinguished from other types of updates once the updates were made. In no case were ACNs and DCNs referred to as subsets of a larger category, DCNs, although that is a common perception and both are submitted to the Air Force intermingled on a type of PTD titled "Design Change Notice."

III. Methodology

Introduction

This chapter describes the methodology used to address the research problem identified in Chapter I. The research effort was conducted in two phases: the process phase and the data phase.

The process phase was an investigation into the DCV process flow. Three sources of information were used for the process phase: 1) the governing regulations, particularly AFLCR 65-33, 2) on site interviews of participants in the process at WR-ALC, and 3) information prepared by the other four ALCs about their local processes. The combination of hands-on evaluation of the process at one center and information about the local processes supplied by the other centers provided the researcher a cost-effective method to access expertise at all five ALCs.

The data phase was a review of the data for provisioning contracts at WR-ALC to describe the quantities and types of DCVs found. Three types of contract groupings were covered: 1) the entire database at WR-ALC, 2) twelve selected completed contracts, and 3) a specific program by itself, LANTIRN.

The Process Phase

Interviews at WR-ALC and inputs from the other centers were used to develop an accurate although simplified block diagram of the DCN process. The block diagram is divided into five different stages. The stages of the DCN process are defined by the flow of the DCN into and out of the Air Force Provisioning System, the D220.

Interviews. Participants in the processing of DCNs at WR-ALC were interviewed. Participation was voluntary and confidential. The selection of interview subjects at each stage of the process was based on the recommendations of supervisors and peers, and the availability of those recommended and their agreement to be interviewed. The interview consisted of the following questions:

1. Which of the data fields of a DCN do you need to do your job?
2. What do you use them for?
3. Do you handle some DCNs differently than others?
4. If so, what are those differences?
5. Where do the forms come to you from?
6. Where do you send them and under what conditions?
7. Under what conditions, if any, is the DCN not necessary for you to do your job?
8. Under what conditions, if any, would you not send a DCN forward?

Other ALC Inputs. The Headquarters AFPC Provisioning Branch PAT on DCNs requested and received a description of

the DCN process flow from the four ALCs other than WR-ALC. The responses varied by level of detail but they were all very similar to the researcher's findings at WR-ALC.

The Data Phase

DCNs were categorized three different ways: 1) they were identified by one of seven TOCCs, 2) they were identified as being either ACNs or DCNs, and 3) they were identified as referring either to procurable or non-procurable items. The DCNs were analyzed by category within the context of the contract grouping to which they belonged. Three types of contract groupings were covered: 1) the entire database at WR-ALC, 2) twelve selected completed contracts, and 3) a specific program by itself, LANTIRN.

The G064. The G064 system at WR-ALC was queried for its content of selected information in an attempt to identify significant similarities and differences that might occur among the contract groupings. The G064 system is an on-line, interactive database that serves as an interface to the more cumbersome and dated flat file provisioning database, the D220 system. The G064 houses all the same data as the D220 and the user appears to be accessing the D220 directly. What actually happens is the G064 files are manipulated and then are periodically sent to the D220 as an update. Afterwards, the updated D220 sends the new files back to G064 for further editing (11:1-4). The G064

provides a fairly convenient, user-friendly means of accessing D220 data. Several G064 queries that directly or indirectly apply to DCNs already exist within the system and were suitable for this research (15:1-6).

The Population. There were 500 provisioning contracts in the G064 system in May of 1989 when the data were gathered. The entire population of all DCNs for all 500 contracts, representing almost ten years of provisioning, were queried to get an aggregate description of DCNs at WR-ALC.

Next, a selection of completed contracts was queried. Completed programs are significant because of the likelihood that the numbers and types of DCNs evolve as a system is produced and eventually fielded. Analyzing a combination of systems in different stages of production and fielding could result in a distorted picture of the types and numbers of DCNs over a program's life. For this research, completed contracts were defined as those contracts with little or no activity in the last two years. A letter requesting a listing of contracts that fit the definition for completed programs was sent to the provisioning office at WR-ALC. The expression "little or no" was deliberately inexplicit to allow the provisioners to use their own judgement as to whether significant numbers of changes had occurred. The letter was circulated among the provisioners for input. Only twelve programs finally were selected as completed and

they were investigated and combined to develop a composite of the completed contracts.

Finally a single program, LANTIRN, was investigated. LANTIRN was selected because it was a large and currently active system managed at WR-ALC that had experienced significant design changes.

Quantities of DCNs Versus Original Data. The three contract groupings were checked for the number of DCNs that were submitted for every 100 original items submitted.

Types of DCNs.

By TOCC. A key element in determining DCN type is the type of change code (TOCC). The TOCC is automatically generated based on the actual type of change that was made. Relative frequencies of the seven TOCCs were gathered for the three kinds of contract groupings.

The six type of change codes found on DCNs follow:

- M Modified item.
- D Deleted item.
- T Typographical error.
- A Quantity increase.
- Q Quantity decrease.
- L Limited part application.

Blank Additional items.

ACNs Versus DCNs. Only LANTIRN was evaluated for whether the changes were actually ACNs or DCNs. This required a closer look including a review of the change

authority block which is not accessed by the quantity and type query. Ten data fields, including Change Authority, were printed out for every DCN submitted on the LANTIRN program to date. Nearly 8,000 DCNs had been submitted. The Change Authority code identifies the authority for a change and is used to differentiate between administrative and engineering changes (3:180,194,458,554; 9:1). If there was an entry in the Change Authority field, the change was counted as a DCN; if the Change Authority field was blank it was counted as an ACN. The totals were used to develop the percentages of DCNs and ACNs.

Since the difference between ACNs and DCNs depended on only one field of information, the Change Authority field, that field was the subject of further scrutiny. Some of the filled Change Authority fields were determined to be not valid. They had entries such as "Adminchg." A second set of percentages was developed that included invalid Change Authority fields that indicated an administrative change as ACNs.

Procurable Versus Non-procurable. Items that were

originally selected for procurement are called procurable items. DCNs submitted against procurable items are defined for this research as procurable DCNs. Items that were originally not selected for procurement are non-procurable items. DCNs submitted against non-procurable items are

defined for this research as non-procurable DCNs. LANTIRN was reviewed for procurable versus non-procurable items.

Analysis

A process flow chart was created based on the information gathered from the AFLCM 65-33, the interviews at WR-ALC, and the inputs from the other four ALCs. The flow was then examined for any obvious redundancies or bottlenecks.

The data were analyzed by category to determine the types and relative quantities of DCNs being submitted. Knowledge about the types and quantities of DCNs was used to identify specific types of DCNs being submitted that were of sufficient magnitude to warrant further investigation or correction.

IV. Findings and Analysis

Introduction

This chapter consists of the results obtained from the two phases of research, the process phase and the data phase, as described in Chapter III.

The Process Phase

The particulars of DCN processing are largely left to the discretion of the individual ALCs. The Air Force provisioning policies and procedures manual, AFLCR 800-9, states that "DCN processing will be similar to LLIL [Long Lead Items List] processing (8:57)." Still, it follows that all the centers will follow very similar processes because there is more specific guidance on LLILs, and because all centers are using the same computerized provisioning system.

A review of applicable regulations, particularly AFLCM 65-33, interviews of DCN process participants at WR-ALC, and inputs requested from the four other centers describing their local processing were used to develop the DCN process flow chart in Figure 1. The chart and associated process flow are intended to represent a generic case that is the typical or most common case AFLC wide. Variations for specific requirements of any given program or center may and do occur.

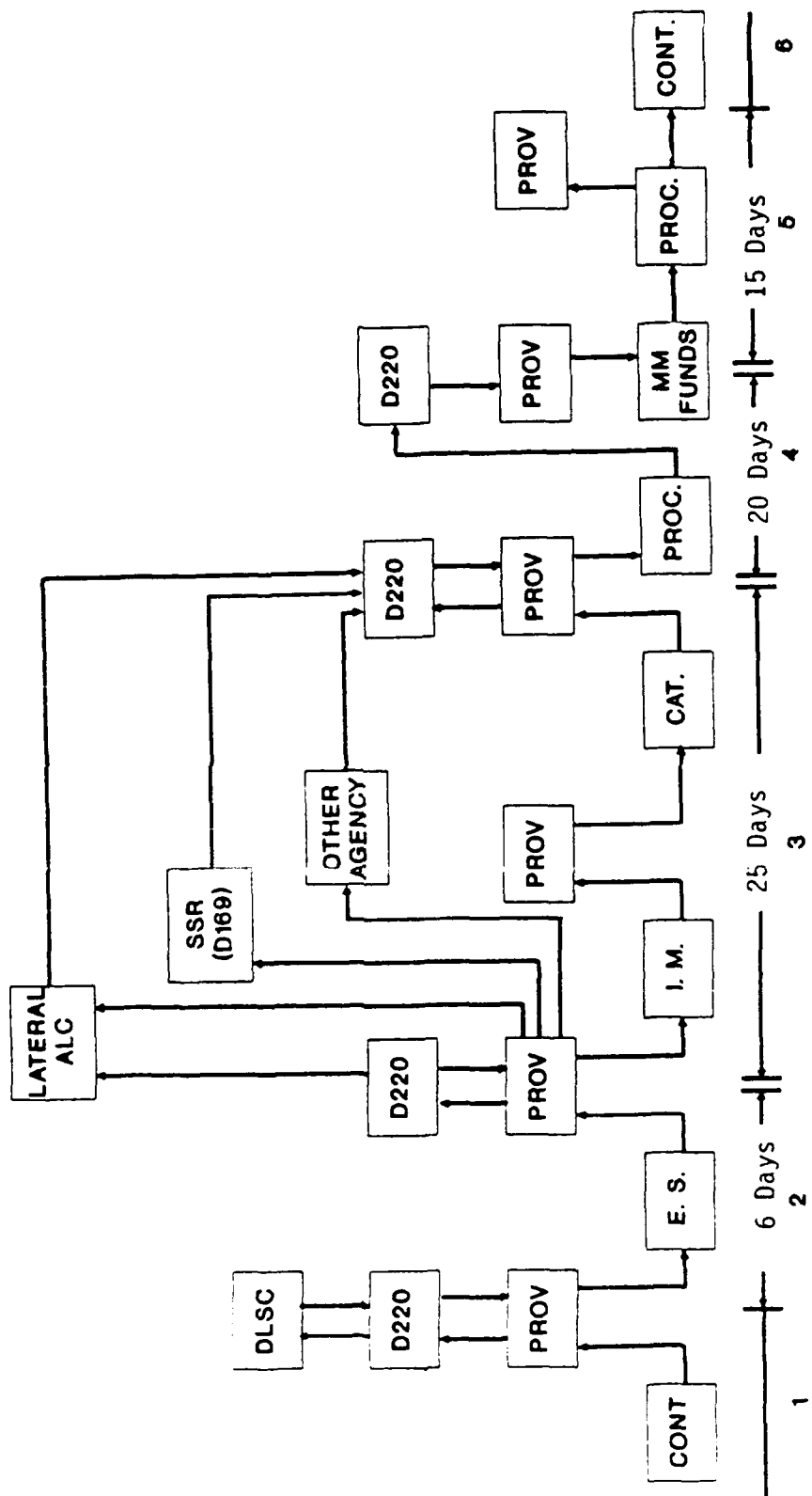

Figure 1. DCN Process Flow

The stages of the DCN process are defined for this document by the flow of the DCN into and out of the D220 system. The number of days identified with the stages represents the internal suspenses assigned by the D220 system. It is possible to change the D220 internal suspenses for any given program when it is deemed appropriate to do so (9:5-22). The primary actions taken at each stage, and the process flow from stage to stage, are described below. Notice in Figure 1 that the provisioning office handles the DCN six times. The major emphasis of the provisioning function is coordination, data input, and data integrity. The provisioning office is responsible for keeping track of the DCN and ensuring that it is processed in a timely manner. To a limited extent they are also responsible for ensuring that the other stages perform their functions correctly.

Stage 1. The first stage includes contractor submittal and initial actions by the ALC provisioning office. The contractor submits the DCN package of magnetic tape and Supplementary Provisioning Technical Data (SPTD) or drawings. The number of DCNs submitted at one time varies depending on program size, magnitude of engineering changes, and government direction. The provisioning office inspects the package and prepares control documentation for the purpose of tracking the DCN to completion. The tape is then input to the D220 system. Subsequent to this initial D220

input, all D220 inputs are made manually through the G064 keyboard.

D220 automatically interfaces with a Defense Logistics Support Center (DLSC) computer to screen and update the DCNs. The screen identifies stock numbers that have already been assigned for any items that are listed without stock numbers. For example, a DCN might be adding a part which, unknown to the contractor, is already in the Air Force inventory; this would greatly simplify the support of that part.

Stage 2. Next, D220 outputs the DCNs back to the provisioning office in the form of a Technical Review Document. This document is then forwarded with the SPTD to the equipment specialist (ES) for technical input.

The ES reviews the DCN to evaluate the technical data fields, particularly the failure and maintenance factor codes, to determine whether they are correct. For example, if the data indicate that a circuit card can be repaired in the field, it is the ES who approves that, yes, this item should be field repairable. But, if an extremely sensitive integrated circuit has been added to the card, that card may no longer be repairable outside the factory or depot, and a change will have to be made. Any changes to the data fields are made by circling the faulty data and handscribing the corrections below it. An ES code is then input to identify the individual equipment specialist who performed the

review. Then the ES returns the DCN to the provisioning office.

The provisioner checks the technical review document for completeness and accuracy. Discrepancies or questionable entries are returned to the equipment specialist for verification. Next, the provisioner inputs the equipment specialist's updates to the D220 by way of the G064. The ES code is the key to the D220 system that the technical review process is complete and Stage 3 may begin. Stage 2, the technical review process, takes six days or less.

Stage 3. An item manager (IM) review document is output to the provisioner from D220 once the technical review document updates are in. The provisioner then routes this document in one of the following three ways: 1) items managed by the Defense Logistics Agency (DLA) are routed to DLA through the supply support request (SSR) system, 2) items managed by other than DLA or Air Force are routed to those managing agencies, and 3) Air Force managed items are routed through either the prime or a lateral ALC. The prime ALC is the ALC assigned management responsibility for the end item, and many of the DCNs are for piece parts that are also managed by the prime ALC. When the part is managed at an ALC other than the prime, that ALC is designated the lateral ALC.

SSR. If the DCN is for an item that is managed by DLA or another service the D220 initiates an SSR through the D220/D169 interface. If the item has already been involved with the D220/D169 interface, for example, an SSR has gone out from the original provisioning and now a DCN has been generated to make a quantity change, then a DCN review document is output to the provisioner. The DCN review document with appropriate SPTD are sent to the SSR unit for manual processing. Since the time that DLA spends with the document is beyond the control of the provisioner and D220, the DCN review document is not suspended by D220 and the D220 update that occurs after the SSR is complete may occur at any time.

Other Agency. Items that are not Air Force or DLA managed are output from D220 as an IM review document to the provisioning office. They are then routed through the Secondary Inventory Control Activity (SICA) ALC to the managing agency for support. The SICA ALC is the ALC designated to represent the Air Force in dealings with the agency that has primary responsibility for a given item. When notification of positive support is received, D220 is updated and that DCN is completed.

Air Force Managed. DCNs for items that are Air Force managed are output from D220 to the provisioning office in the form of an item manager review document. DCNs for items that are locally managed, or prime, are sent to a

local item manager. Non-prime DCNs for items which are not stocklisted are forwarded to the appropriate lateral ALC provisioning office where they are handled in much the same way the prime items are handled. Non-prime DCNs for items which are stocklisted are sent directly to the lateral ALC by the D220 through the AFLC Responsive Circuit (ARC).

The item manager reviews the DCN for possible impact on existing order quantity computations. If there are no previous computations then an initial computation is accomplished. The item manager updates his records to reflect any changes that have resulted from the DCN. A method of support (MOS) code is checked or assigned by the item manager. The MOS code tells D220 whether or not the item will be procured on a Provisioned Item Order (PIO). The DCN is annotated to reflect the latest buy quantities as required. Buy quantities may be increased or decreased depending on the nature of the change identified by the DCN. The annotated IM review document is then returned to the provisioning office.

If a cataloging action is indicated, the provisioner forwards the IM review document to the cataloging section. The cataloging specialists review the DCN for a requirement for a National Stock Number (NSN). They then assign a temporary stock number and initiate the assignment of a permanent NSN. The DCN is annotated with the temporary number and returned to the provisioning office.

The IM review document updates are then input to D220 by the provisioner. The non-prime D220 sends the information back to the prime D220 at this point by way of the ARC system. DCNs from both the prime and non-prime ALCs should be back in the prime D220 by 31 days after initial establishment of the DCN in the D220. Stage 3 takes no more than 25 days.

Depot Team. For large quantities of related DCNs to be accomplished expeditiously, a depot team is sometimes formed to perform most of the actions required in Stages 2 and 3. Team members include a provisioner, an equipment specialist, an item manager, and a cataloger. DCN conveyance time between each of these disciplines and provisioning is eliminated. The provisioner annotates the technical review document with inputs from all participants who annotate their own copies for their records. The provisioner still must input technical review data to D220 and wait for an IM review document before inputting the IM and cataloging data, but the depot team can still be very effective for processing large quantities of DCNs.

Stage 4. The D220, having been updated with IM and cataloging information, next outputs a PIO review listing to the provisioner. It includes additional items to be procured as well as any changes that might have occurred to existing PIOs. This listing is sent by the provisioner to the procurement office.

The procurement office assigns a contract modification number (MOD-NR) for each entry in the review list and then inputs the MOD-NR directly to the G064 and consequently the D220. This is the only stage where the D220 is updated by someone other than the provisioner. Stage 4 is completed within 20 days.

Stage 5. Next D220 outputs a hard copy final PIO back to the provisioner. A PIO that deletes or withdraws a procurement is known as a delete PIO, and a PIO that procures an additional item is known as an add PIO. A small change to an item often results in a delete of that item and an add of the "new" slightly changed item. The provisioner matches up any delete PIOs that should be paired with any add PIOs so they will be processed at the same time. They are matched so the contractor will not receive a delete PIO and stop work only to find that an add PIO was coming for the same basic item. Then the provisioner forwards the PIO to the procurement office through the ALC's Materiel Management (MM) funds office. MM funds tracks spending by weapon system. The procurement office arranges for the printing and distribution of the PIOs to the contractor. A copy of each final PIO is also sent back to provisioning. Stage 5 should occur within 5 days.

The Data Phase

The DCNs were analyzed within the context of the contract grouping to which they belonged. Three types of contract groupings were covered: 1) the entire database at WR-ALC, 2) twelve selected completed contracts, and 3) a specific program by itself, LANTIRN.

First, the three contract groupings were evaluated for the quantities of DCNs versus the number of line items originally submitted. Next, they were evaluated for their relative quantities of the seven TOCCs. Finally, the LANTIRN program was evaluated for the numbers of ACNs versus DCNs, and procurable versus non-procurable DCNs. Procurable DCNs are DCNs submitted against items that were originally selected for procurement. Non-procurable DCNs are DCNs that are submitted against items that were not originally selected for procurement.

Quantities of DCNs Versus Original Data. Figure 2 displays the quantities of DCNs submitted per 100 original items. The entire database had about 20 DCNs per 100 original submittals, and LANTIRN had about 45. The completed contracts had far different results. They had about 225 DCNs per 100 original items. Original data were unavailable for three of the twelve completed contracts, but of the remaining nine, six had more DCNs than items originally submitted. One had no original submissions at all and two others had less than ten. In such cases it

appears likely that DCNs are being used for other than their primary purpose. For example, a small program might approve submitting only major subassemblies originally and use DCNs to submit all of the components.

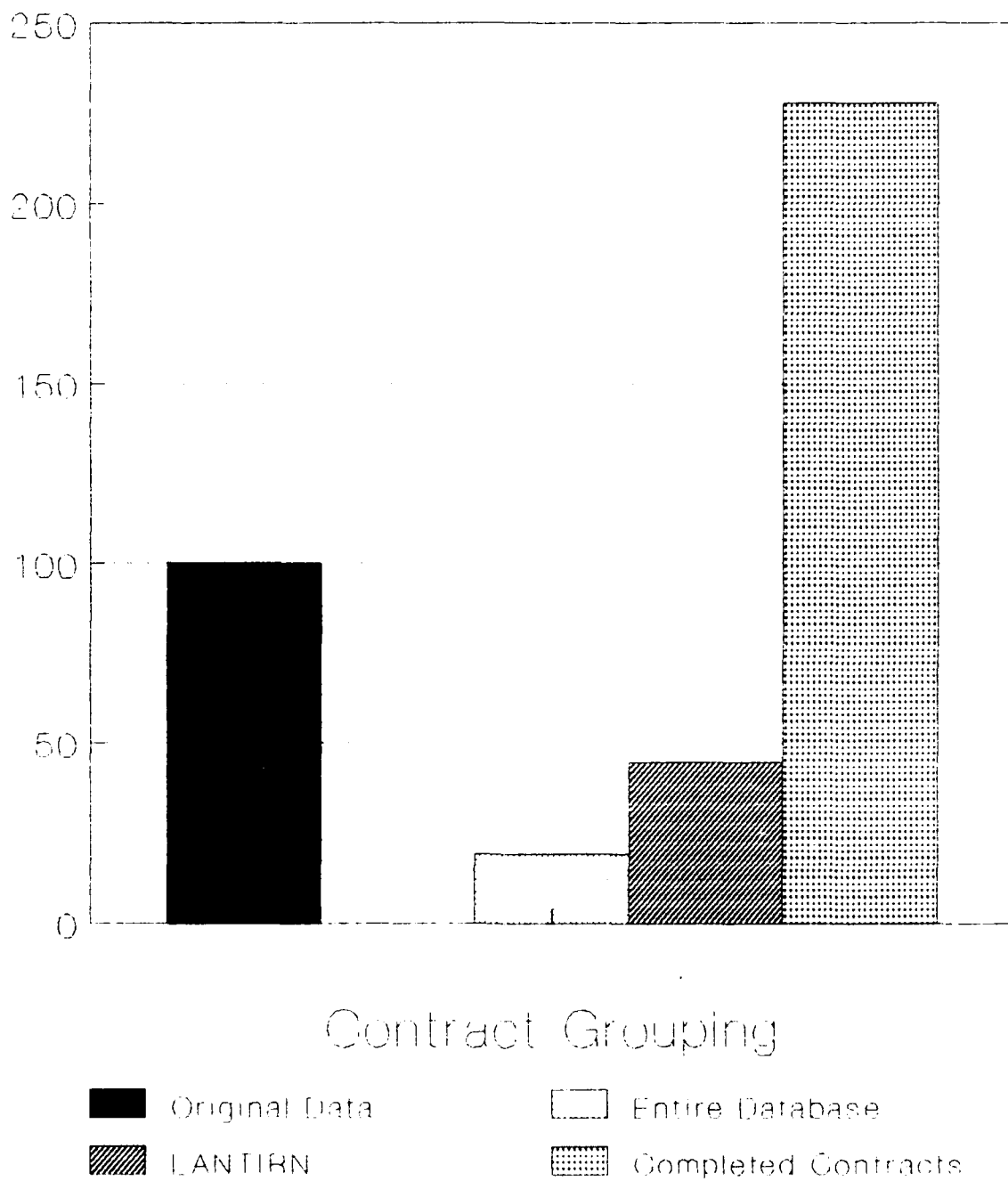

Figure 2. Quantities of DCNs per 100 Original Items

By TOCC. The different TOCCs and their relative percentages of total DCNs per contract grouping follows. The results are presented in figure 3. With a few exceptions the three contract groupings all had the same order by weight of the seven different TOCCs.

Additional Item. A blank TOCC indicates that the DCN is written to initiate an additional item into the provisioning record. Usually a DCN with a blank TOCC is associated with and replaces a DCN with a delete TOCC. An additional item DCN is referred to as a "to" and a deleted item DCN is referred to as a "from". In other cases, a blank TOCC means that a completely new item, a fuse for instance, has been added. Not surprisingly, blank TOCCs were the single most common of the change codes for all three of the contract groupings. Between 40 and 50 percent of all DCNs studied had blank TOCCs.

Deleted item. A TOCC of D is used for items that are to be deleted from the provisioning record. D is the second most prevalent TOCC for all three contract groupings, ranging from 24 to 42 percent. LANTIRN had the highest percentage of D codes, but it also had the highest number of blank codes. Note that upgrading a single component, a precision resistor to replace an ordinary resistor for example, requires submittal of two notices, one with a D and one with a blank TOCC. The facts that Ds and blanks are often paired together and that the two represented between

73 and 91 percent of all DCNs is noteworthy. In a GAO report on B-1B parts problems, design changes and design change notices are used interchangeably (7:30). They are not interchangeable. If a single part changes, two notices are likely to result.

Modified Item. Modified items are identified by a TOCC of M. They are items that have been changed as opposed to replaced. The change may result either from engineering or administrative requirements. The completed contracts had the highest percentage of modified items at 24.5 percent. The WR-ALC database had 15, and LANTIRN had 3 percent. The modification may be the result of an approved engineering change, or it may have resulted from an administrative change such as an erroneous data entry other than one caused by typographical error.

Quantity Decrease. A TOCC of Q indicates a decrease in the quantity of a given item with respect to the end item. The DCN submitted when one of three identical power supply's was no longer needed would have a TOCC of Q. Quantity decreases represented less than 10 percent of the DCNs for all three contract groupings.

Limited Application. Limited application changes are TOCC L. Limited application changes occur when a part is changed that only applies to some of the end items. For example, the first 50 aircraft off the assembly line might have one avionics system while the next 50 have an upgraded

avionics. The avionics systems and their spare parts will now have limited application to the serial numbered end items they came with. No L TOCCs were found in the completed contracts or in LANTIRN. The WR-ALC database had only 2.5 percent limited application DCNs.

Typographical Error. Typographical errors are corrected through the use of T coded DCNs. All three contract groupings had less than two percent typographical change DCNs. This is important in light of the fact that AFLCM 65-33 stated that data elements changed by the contractor would have a TOCC of T (7:6-12, 6-13).

Quantity Increase. A quantity increase is identified by the use of a TOCC of A. If a third power supply identical to two others was added to a system that previously had only the two, it would call for a quantity increase TOCC. None of the three contract groupings had even half of a percent of A coded DCNs.

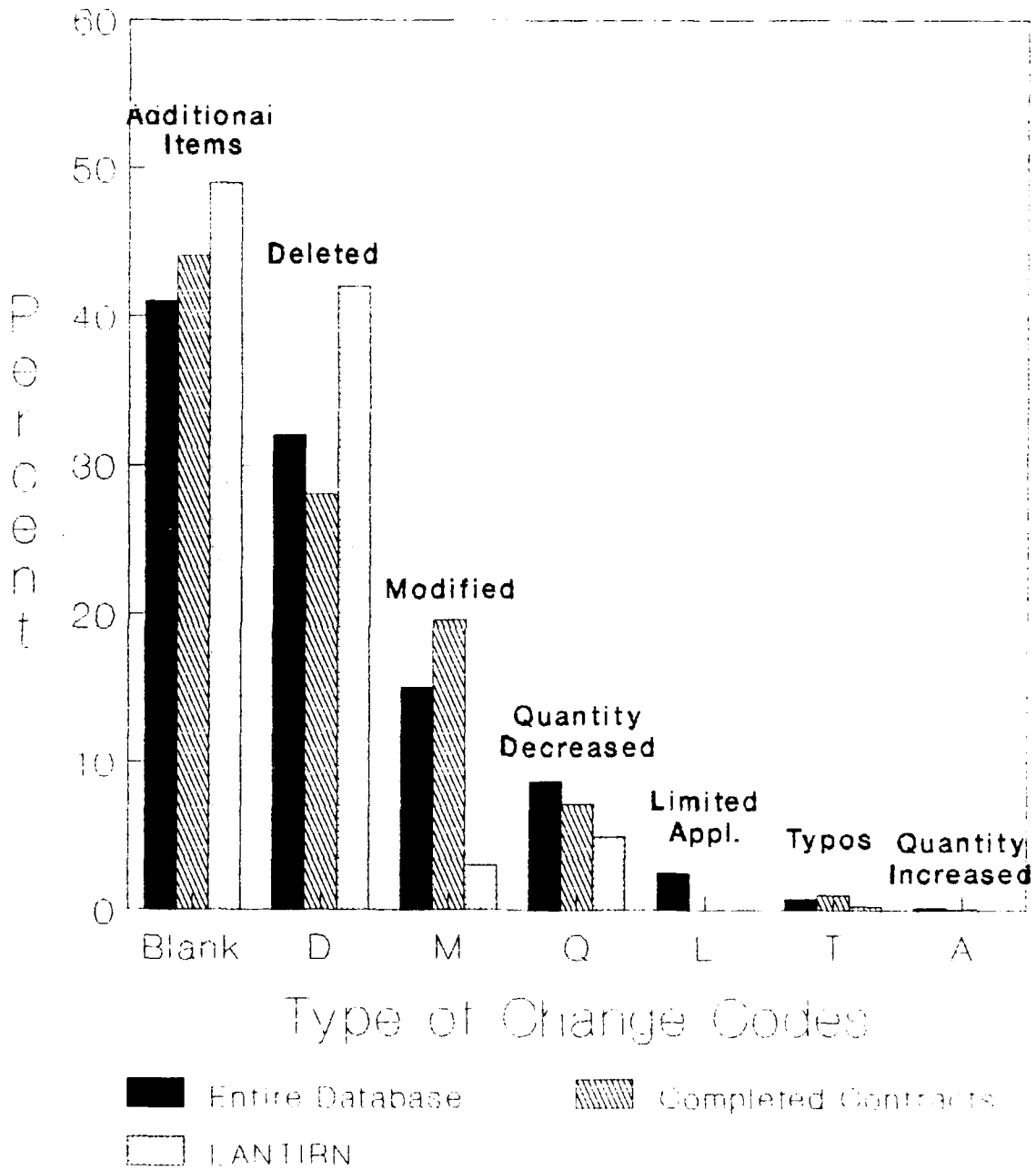

Figure 3. Percentages of Types of Changes, WR-ALC

ACNs Versus DCNs. The LANTIRN program was evaluated for the quantities of ACNs versus DCNs. Administrative change notices (ACN) occur for reasons other than government approved engineering changes. Errors in original data submissions, for example, would result in ACNs to correct them at a later date.

The "traditional" discriminator based on AFLCM 65-33 and the Air Force Addendum is that ACNs or Change Actions, (CAs) are identified by a blank Change Authority field or a TOCC of T. That is, they are not based on approved engineering changes. Using the "traditional" discriminator, only three percent of the changes submitted on LANTIRN were ACNs.

The weakness of using a blank Change Authority field to identify ACNs is that the field might be filled incorrectly with something other than a valid approved engineering change number. A review of the Change Authority fields on the LANTIRN DCNs did show up exactly that: inputs other than approved engineering change numbers. Instead of correctly identifying the authority by which the change was made, the block was sometimes filled with words such as "typo" or "admin-chg." No guidance was found that specifically stated what kind of "authority" was required for the Change Authority block or what the format should be, so it was not possible to validate or invalidate every change authority number for LANTIRN. Eliminating only the

change authority codes that were obviously not the result of approved engineering changes increased the percentage of LANTIRN ACNs from five percent to nineteen percent. These are considered to be "not traditionally identified." Traditionally and not traditionally identified ACNs are presented in Figures 4 and 5, respectively.

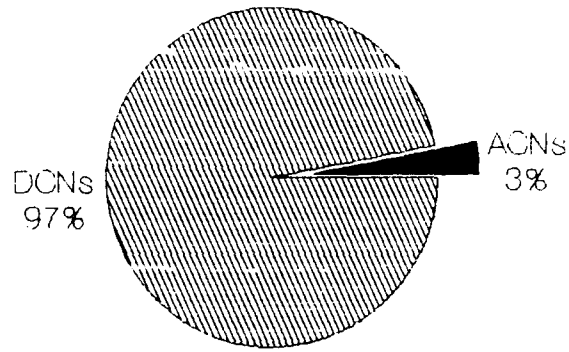

Figure 4. Traditionally Identified ACNs

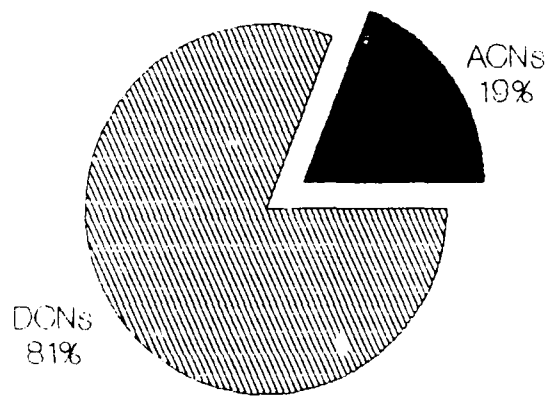
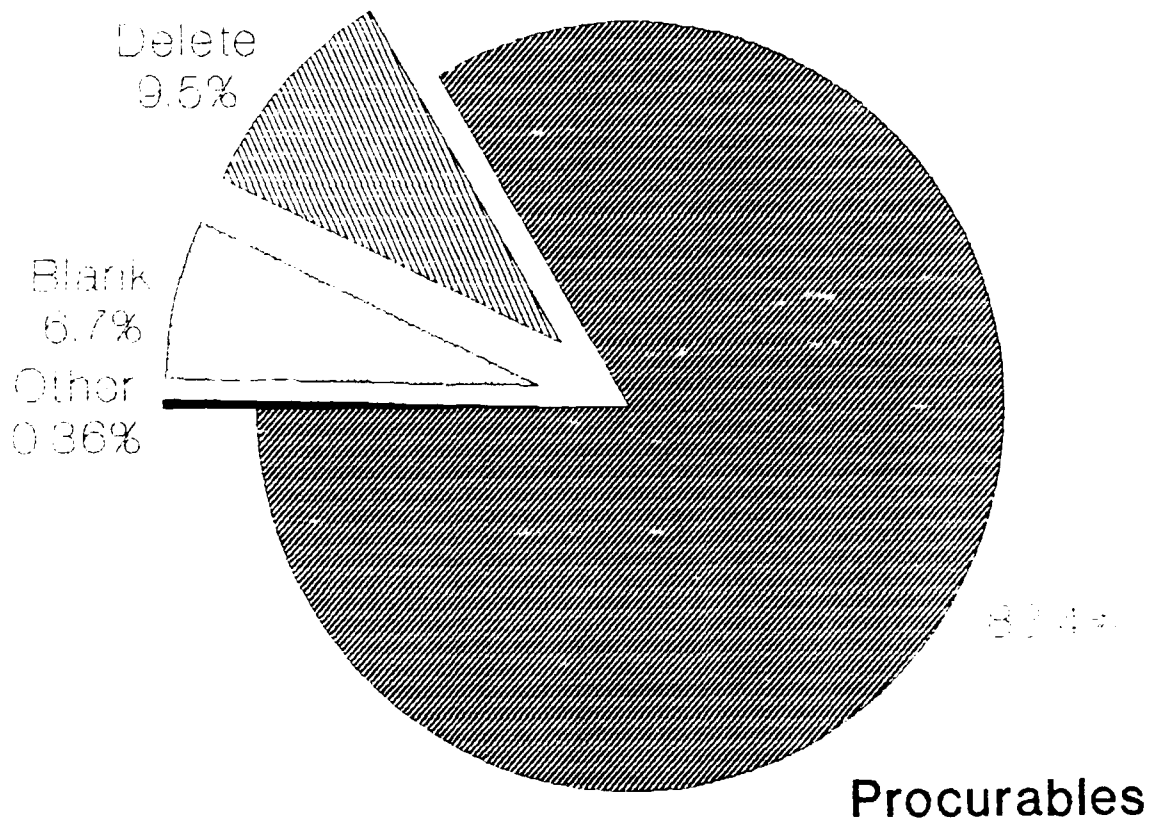

Figure 5. Not Traditionally Identified ACNs

Procurable Versus Non-procurable. The purpose of provisioning data is to provide information that can be used to select and procure support items necessary to operate and maintain the end item for some initial period of service (5:4). If a change is made to a non-procurable support item, one that has not been selected as necessary for the operation or maintenance of the end item, then the change will be much less important to the provisioning system than if the item had been procurable, or necessary. MIL-STD-1561B recognizes this and places a reduced time requirement on submittal of non-procurable items by the contractor (5:13). In fact, non-procurable items are accepted in the form of a listing instead of on formal DCNs, or they are not required at all. LANTIRN DCNs were reviewed for the number submitted against non-procurable items.

Of the 7,960 DCNs in the LANTIRN file, 1324, almost 17 percent, were against non-procurable type items. The 17 percent were made up primarily of delete and blank TOCCs. Other than their being for non-procurable items, the DCNs appeared to be routine, that is, made up primarily of add and delete TOCCs. It appears that, at least for LANTIRN, changes to non-procurable items may be being submitted the same way as any other change. Procurable versus non-procurable DCNs are presented in Figure 6.

Non-Procurables



(Broken Out by TOCC)

Figure 6. LANTIRN Non-procurable DCNs

V. Conclusions and Recommendations

Introduction

The purpose of this research was to describe DCNs and DCN processing in the Air Force. A flow chart of the way DCNs are currently processed was developed and information about the quantities and different types of DCNs submitted was gathered. This chapter contains conclusions and recommendations based on the information gathered as presented in Chapter IV.

The Process Phase

The review of the process phase resulted in the development of the process flow chart presented in Figure 1.

Conclusion. It was thought that the actual process flow might vary dramatically from one ALC to the next. This did not turn out to be the case. Because the D220 system input and output hard-copy products are needed at every stage in the process, and because the provisioning office is tasked with inputting updates and routing and tracking output documentation, the bulk of the process is fixed. Unfortunately, although the process is similar from ALC to ALC, it is not adequately described in the Air Force provisioning policies and procedures regulation. For the most part, the provisioning office serves as an interface between the D220 computer and the real users of the data

such as equipment specialists, item managers, catalogers and procurement officers. The DCN passes through the provisioning office six times before the process is complete. This time consuming and labor intensive processing system is obviously inefficient.

Recommendation. The computer portion of the DCN processing system should be improved to be able to route and track its own products and allow direct screen inputs. Some improvements could be made to the D220, but it is now frozen to change while a completely new system is developed that will route and track with direct screen inputs (14:1). The need for such a system is indisputable and its development and implementation should be a high priority for the Air Force. *In the meantime*, process changes to the existing system are unlikely. What can be done now is to better describe the existing process in the governing regulations, particularly AFLCR 800-9, Air Force Provisioning Policies and Procedures, in hopes that the existing procedures, if better understood, will work more smoothly. The process flow chart and accompanying explanation in Chapter IV should be readily adaptable to AFLCR 800-9.

The Data Phase

The Data phase of the research first provided quantities of DCNs versus original submittals. Next DCNs were broken down by TOCC, ACN or DCN, and Procurable or Non-

procurable. Relative percentages for the various types of DCNs were provided for three different types of contract groupings: the entire database at WR-ALC, selected completed contracts, and a specific program by itself, LANTIRN.

Quantity Versus Initial Submission. This phase of the research attempted to describe the numbers of DCNs likely to occur for a given number of items originally submitted. The results are graphically presented in Figure 2.

Conclusion. There is no apparent dependent relationship between the quantity of DCNs and the quantity of original submittals. Although the entire database averaged about twenty DCNs per hundred original data items, and LANTIRN more than doubled that figure to 44 per hundred, the completed contracts, at 228 DCNs per hundred items, were not in the same league. The extremely high numbers for the completed contracts appeared not to realistically represent a typical program. Out of nine completed contracts tested, six had more DCNs than items originally submitted, one had no original submissions at all, and two others had less than ten. It makes no sense that changes could be made if there were no data to begin with.

Recommendation. It is not proven by the data submitted here, but it does make sense intuitively, that 20 to 44 DCNs could be expected for every 100 items originally submitted. Numbers as high as 228 per 100 are far different and hint that other factors may be at work. Since one of

the completed contracts had no original items at all, and the other contracts had two or more changes submitted on average for every original item, it becomes apparent that the system was being used in a manner inconsistent with that for which it was originally intended.

One of the great strengths of the Air Force acquisition system is that most requirements, processes, and regulations can be tailored or at least tempered to make them compatible with the specific weapon system being acquired. Otherwise, there would be no need for, nor advantage to, weapon system management. Still, management tools like the provisioning system are not uncomplicated and should be used carefully. They evolve, slowly, incrementally, and in concert with many other systems. Imaginative management is to be applauded, but a good dose of caution is in order as well.

By TOCC. TOCCs are assigned automatically by the LSA software as described in MIL-STD-1388-2A. The percentages of the different Air Force TOCCs for the three contract groupings are presented in Figure 3.

Conclusion. There is little difference between programs as to the percentages of the various TOCCs that will be submitted. Blank for additional items and D for deleted items represent by far the majority of TOCCs submitted. One of each is submitted when an item is deleted and another item takes its place; this represents two DCNs

for one change. Large numbers of DCNs, then, can represent much smaller numbers of actual design changes.

That the relative quantities of the different TOCCs appeared comparable for all the contract groupings is useful because the general pattern is likely to be repeated for any new program. Unfortunately, the description in the regulations, of the different TOCCs and how they are assigned, is so obscure as to make the information about specific codes much less valuable than it could be. The D220 does not use a TOCC of G and converts Q to either Q for quantity decrease or A for quantity increase. Neither AFLCR 65-33, AFLC Provisioning System (D220) Users Manual, nor AFLCR 800-9, Air Force Provisioning Policies and Procedures, explain what happens to TOCC of G in the Air Force system, nor do they ever mention the Q to A conversions. A TOCC of T for typographical error is so seldom used as to be insignificant, but there is no code to differentiate the myriad other possible types of contractor errors.

Recommendation. The catch-all name of DCN should be replaced by Provisioning Data Update or something to that effect. This is much less confusing, more accurately represents what is really happening, and avoids misunderstandings about the magnitude of design changes in Air Force acquisitions. The GAO report to Congress on B-1B parts problems misleadingly stated that the Air Force had received 187,500 design changes from contractors (7:30).

These were really DCNs, not necessarily design changes. The actual number of design changes, that should have been reported to Congress, was certainly much less than what was actually reported.

A detailed but lucid explanation of how TOCCs are "automatically" assigned should be included in MIL-STD-1388-2A. Details of how the Air Force converts MIL-STD-1388-2A TOCCs to the codes assigned by D220 should be included in the Air Force Addendum and in AFLCM 65-33. An understanding of exactly how the TOCCs are assigned is needed to understand what is represented by any given TOCC. For example, it is very interesting to note that less than two percent of all DCNs had a TOCC of T, but the significance is lost if there is no way to tell whether a quantity increase, TOCC Q, was due to an actual change in the item quantity or was due to a typographical error, TOCC T.

MIL-STD-1388-2A and the associated software should be changed to expand the definition of TOCC T to include any error corrections not due to a change to the actual hardware. This is one way to get at some of the "why" of changes instead of just the "what." It is hoped that knowledge about why DCNs are occurring will lead to more proactive management and eventually to fewer DCNs submitted.

ACNs versus DCNs. ACNs are changes to provisioning data that are due to other than an approved change to the design. The percentage of LANTIRN DCNs that are due to

other than approved changes to the design are presented in Figure 4.

Conclusion. The LANTIRN program had a significant number of ACNs submitted. Using the guidance in the Air Force Addendum, that ACNs can be identified by a blank change authority field, there were only three percent ACNs. A closer analysis of what exactly was in those change fields that were filled revealed that many were filled with information other than what was expected. At least nineteen percent of DCNs submitted were actually ACNs. ACNs occur in large enough quantities (at least on LANTIRN) to warrant different processing procedures.

Recommendation. Only the LANTIRN program was evaluated for the number of ACNs submitted, so the large number of ACNs submitted could well be LANTIRN specific. The change authority fields on a larger selection of programs than just LANTIRN could be evaluated, but since the guidance on what ACNs are and how Change Authority fields should be filled out is weak, it is not certain that further research would be fruitful. The potential for large numbers of ACNs on any program is already clear. ACNs should be addressed immediately.

The first step is to strengthen guidance on what ACNs are and how Change Authority fields are to be filled out. MIL-STD-1561B should be changed to be compatible with MIL-STD-1388-2A in addressing updates other than those resulting

from approved changes. As recommended earlier, a category such as Provisioning Data Updates should be created that includes ACNs as well as DCNs. The Air Force Addendum, MIL-STD-1388-2A, and AFLCR 800-9 should be changed to be more specific about what is acceptable in the change authority field. The field should contain only the number of the engineering change that was approved by the government and resulted in the provisioning data change. If the change was due to other than an approved engineering change, the Change Authority field should be left blank.

Since ACNs are not due to approved changes to the design, it is reasonable to assume that they are much less likely to affect buy quantities of support items than DCNs which are due to actual design changes. Changes that do not affect support item buys are not significant to the provisioning process. Some ACNs however, may impact existing procurement actions or prompt new procurement actions. Those that do have an impact should be separated from those that do not. Provisioning specialists may be able, in many cases, to judge which ACNs will or will not affect procurement, but they do not have the experience nor the authority to make that decision. It is the equipment specialist and item manager that are ultimately responsible, so they must make the actual decision. However, if all ACNs must be routed through the equipment specialist and item

manager, the process is the same as that for DCNs, and the advantage of separating ACNs from DCNs is lost.

The problem might be overcome by the development of a simple yet formal decision rules table similar to that shown in Table 2. For example, if the part number does not change, and key named data fields do not change, then no further action is needed; if the part number is changed, the key fields are not changed, and procurement of the original part number has already been initiated, then only procurement need be involved; and so forth.

Table 2. ACN Decision Rules Table

	Rule	Action
A	part number changed part number not changed	B C
B	key data not changed key data changed	Forward PIO rev doc Forward Tech rec doc
C	key data not changed key data changed	No Action D
D	existing PIO no existing PIO	Forward PIO rev doc No Action

With such a table in hand, the provisioner would initiate further processing of only those ACNs that affect provisioning and would initiate that processing at the stage indicated. In the case of only procurement being involved, the provisioner would enter the technical review and IM review documents with no changes and would forward only the

PIO review document directly to the procurement office. The decision rules table development might best be managed by the Headquarters Provisioning Policy office, in collaboration with the five ALCs. The ALCs could provide the inputs and coordination of the various disciplines involved, particularly the equipment specialist and item management offices. By formally including the equipment specialist and item management offices in the decision rules table development, including the designation of key data fields, the authority problem might be overcome.

Procurable Versus Non-procurable. DCNs for non-procurable items are of no consequence to a provisioning system that exists to procure initial spares. The number of DCNs submitted for non-procurable items relative to procurable items is presented in Figure 5.

Conclusion. DCNs for non-procurable items represented over sixteen percent of the DCNs submitted against LANTIRN. If there is a policy that DCNs for non-procurable items should not be submitted, it is not being universally followed. Like ACNs that have no effect on provisioning, DCNs for non-procurable items have no effect on provisioning.

Recommendation. Ensure that contractors are directed not to submit DCNs for non-procurable items unless the change is such that the item is now recommended for procurement. For example, if a non-procurable item is being

slightly modified, a DCN should not be submitted, but if it is being modified to the point that it should now be a procurable item, a DCN should be submitted. Ideally, a D220 edit should be written to ignore DCNs that are for non-procurable items, but D220 changes are not being made because of the new provisioning system that is being developed. When DCNs for non-procurable items are submitted to the provisioning office, further processing should not be initiated.

General Discussion. Updates to provisioning data can be categorized by TOCC, they can be categorized as resulting from either administrative or engineering changes, and they can be categorized as affecting procurable or non-procurable items. These categories can be exploited to increase the efficiency of DCN processing, and recommendations have been made to that effect. In each case the category that is most important to provisioning is emphasized and the category least important is de-emphasized.

A single, broader, simpler category might be appropriate. DCNs could be segregated only by whether they affect provisioning or do not affect provisioning. All the fields of a DCN, Change Authority, TOCC, and the rest would be used. A decision table like the one recommended for processing ACNs, only far more detailed, would have to be developed. DCNs that do not affect provisioning would never be output for processing. This type of categorization would

be complex and would almost have to be computerized. In the long term, the segregation could be included in the software of the new provisioning system currently under development. By developing the small scope, manual decision rules table for ACNs, the feasibility of program encompassing all updates could be demonstrated or discredited.

Summary

The process flow documented is not subject to significant improvement because the baseline on the D220 system it supports is frozen. Opportunity does exist to document the process in the provisioning policy and procedures regulation.

No relationship between the number of original submittals and the number of DCNs was discovered, but programs managed in accordance with existing policies and procedures would be expected to have considerably less than a one to one ratio.

The most common DCNs are to delete items and to add items. Often the deletion and addition are for the same design change, so the number of design changes is substantially less than the number of DCNs.

The general category, DCNs, should be renamed and should include updates resulting from changes to the design. DCNs, as well as those not resulting from a change to the design, ACNs. ACNs appear to be of large enough frequency

to warrant development of their own special procedures. A decision rules table might be helpful for ACN processing.

A significant number of DCNs for non-procurable items are being submitted, apparently unnecessarily. DCNs for non-procurable items do not impact provisioning and should not be submitted nor processed.

DCNs could be segregated into two categories: either they affect provisioning or they do not. Those that do not should not be processed. Software should be developed as a part of any new provisioning system that could identify and edit out changes that do not impact provisioning.

Bibliography

1. Aceto, Joseph E. Correspondence. HQ AFLC, Wright-Patterson AFB OH, July 1988.
2. Department of Defense. Configuration Control-Engineering Changes Deviations and Waivers. MIL-STD-480B. Washington: HQ USAF, 15 July 1988.
3. Department of Defense. DOD Requirements for a Logistic Support Analysis Record. MIL-STD-1388-2A. Washington: HQ USAF, 20 July 1984.
4. Department of Defense. Provisioning of End Items of Equipment. DODD 4140.40. Washington: Government Printing Office, 28 June 1983.
5. Department of Defense. Provisioning Procedures, Uniform Department of Defense. MIL-STD-1561B. Washington: HQ USAF, 17 November 1984.
6. Department of Defense. Provisioning Technical Documentation Uniform DOD Requirements. MIL-STD-1552A. Washington: HQ USAF, 17 March 1981.
7. Department of the Air Force. AFLC Provisioning System (D220) Users Manual. AFLCM 65-33. HQ AFLC, Wright-Patterson AFB OH, 31 March 1988.
8. Department of the Air Force. Air Force Provisioning Policies and Procedures. AFLC Regulation 800-9. HQ AFLC, Wright-Patterson AFB OH, 20 June 1986.
9. Department of the Air Force. MIL-STDs-1388-2A and 1561B Provisioning Requirements Statement Air Force Addendum to DD Form 1949-2. AFLCR 800-9 Attachment 7. HQ AFLC, Wright-Patterson AFB OH, 25 Aug 88.
10. Department of the Air Force. Source, Maintenance, and Recoverability Coding of Air Force Weapons, Systems, and Equipments. TO 00-25-195. OC-ALC, Tinker AFB OK, 1 December 1984.
11. Department of the Air Force. User Manual for AFLC Management and Control of Provisioning System DSD G064. OO-ALC, Hill AFB UT, 10 November 1986.

12. General Accounting Office. Strategic Bombers: B-1B Parts Problems Continue to Impede Operations. Report to the Chairman, Committee on Armed Services, House of Representatives, GAO/NSIAD-88-190. Gaithersburg MD, July 1988.
13. Nucci, E. J. "Questionnaire on Design Change Notices." Correspondence. Electronic Industries Association, 2001 Eye Street, Washington DC, 1 February 1988.
14. Ostrognai, E. R. Correspondence. HQ-AFLC/DCS/MM, Wright-Patterson AFB OH.
15. "Query General Instructions." Unpublished G064 Query Guidance. HQ AFLC, Wright-Patterson AFB OH, 13 March 1987.
16. Shively, Jon W. Correspondence. OO-ALC, Hill AFB UT, 25 May 1989.

Vita

Joseph W. Burns was born on 30 August 1956 in Frankfurt, Germany. He graduated from high school in North Highlands, California in 1974. Mr Burns began his career in the Department of the Air Force at Sacramento Air Logistics Center in 1977. He served for four years in each of the Directorates of Supply, Maintenance, and Materiel Management while attending college part time. In 1984 he received an Associate of Arts degree in Business and an equivalent certificate in Electronic Computer Technology from American River College. In 1988 he received a Bachelor of Science degree in Business Administration (Production, Operations, and Systems Management) from California State University, Sacramento. In June of 1988 he entered the School of Systems and Logistics, Air Force Institute of Technology.

Permanent Address: 7509 Park Drive
Citrus Heights CA 95610

REPORT DOCUMENTATION PAGE				Form Approved OMB No. 0704-0188	
1a. REPORT SECURITY CLASSIFICATION UNCLASSIFIED		1b. RESTRICTIVE MARKINGS			
2a. SECURITY CLASSIFICATION AUTHORITY		3. DISTRIBUTION/AVAILABILITY OF REPORT Approved for public release; distribution unlimited			
2b. DECLASSIFICATION/DOWNGRADING SCHEDULE					
4. PERFORMING ORGANIZATION REPORT NUMBER(S) AFIT/GLM/LSM/89S-5		5. MONITORING ORGANIZATION REPORT NUMBER(S)			
6a. NAME OF PERFORMING ORGANIZATION School of Systems and Logistics		6b. OFFICE SYMBOL (If applicable) AFIT/LSM	7a. NAME OF MONITORING ORGANIZATION		
6c. ADDRESS (City, State, and ZIP Code) Air Force Institute of Technology Wright-Patterson AFB OH 45433-6583		7b. ADDRESS (City, State, and ZIP Code)			
8a. NAME OF FUNDING/SPONSORING ORGANIZATION		8b. OFFICE SYMBOL (If applicable)	9. PROCUREMENT INSTRUMENT IDENTIFICATION NUMBER		
8c. ADDRESS (City, State, and ZIP Code)		10. SOURCE OF FUNDING NUMBERS			
		PROGRAM ELEMENT NO.	PROJECT NO.	TASK NO.	WORK UNIT ACCESSION NO.
11. TITLE (Include Security Classification) DESIGN CHANGE NOTICES IN AIR FORCE SPARES ACQUISITION					
12. PERSONAL AUTHOR(S) Joseph W. Burns, B.S.					
13a. TYPE OF REPORT MS Thesis		13b. TIME COVERED FROM _____ TO _____		14. DATE OF REPORT (Year, Month, Day) 1989 September	15. PAGE COUNT 70
16. SUPPLEMENTARY NOTATION					
17. COSATI CODES			18. SUBJECT TERMS (Continue on reverse if necessary and identify by block number)		
FIELD	GROUP	SUB-GROUP			
15	05		Logistics Spare Parts Air Force Procurement		
19. ABSTRACT (Continue on reverse if necessary and identify by block number) Thesis Advisor: Charles F. Youter Assist Prof of Log Mgt Approved for public release: IAW AFR 190-1. <i>Larry W. Emmelhainz</i> LARRY W. EMMELHAINZ, Lt Col, USAF 14 Oct 89 Director of Research and Consultation Air Force Institute of Technology (AU) Wright-Patterson AFB OH 45433-6583					
20. DISTRIBUTION/AVAILABILITY OF ABSTRACT <input checked="" type="checkbox"/> UNCLASSIFIED/UNLIMITED <input type="checkbox"/> SAME AS RPT <input type="checkbox"/> DTIC USERS			21. ABSTRACT SECURITY CLASSIFICATION UNCLASSIFIED		
22a. NAME OF RESPONSIBLE INDIVIDUAL Charles F. Youter, Assist Prof			22b. TELEPHONE (Include Area Code) (513) 255-5023	22c. OFFICE SYMBOL AFIT/LSM	

UNCLASSIFIED

A new Air Force weapon system, if delivered before the support items needed to sustain its use, is not a credible threat or deterrent. To ensure concurrent delivery of support items and the end item, provisioning data, used to initiate procurement of the support items, is processed long before production of the end item is completed. Due largely to the complexity of new Air Force systems, changes to the design frequently occur after the original provisioning data is submitted. Design Change Notices (DCN) are used to notify the Air Force of changes that have occurred to the provisioning data. The volume of changes being submitted threatens to overwhelm the Air Force provisioning process and obviate the advantage of processing the data early to begin with.

This research describes DCNs and DCN processing in the Air Force. A flow chart of the current DCN process illustrates that the process is repetitive and inefficient, but the process is inextricably linked to the Air Force provisioning data system. A new data system must be developed to solve the process inefficiencies. In addition, many DCNs that are being submitted and processed do not impact support item procurement. These must be identified and edited out rather than be processed unnecessarily.

UNCLASSIFIED

END

FILMED

1-90

DTIC