

2

AD-A215 748



AN OPERATIONAL SUITABILITY EVALUATION  
 TECHNIQUE FOR AVIONICS SUPPORTED WITH  
 TWO-LEVEL MAINTENANCE

Thesis

Rodney C. Motley, B.S.  
 Captain, USAF

AFIT/GSM/ENS/89S-30

DISTRIBUTION STATEMENT A  
 Approved for public release;  
 Distribution Unlimited

DTIC  
 ELECTE  
 DEC 20 1989  
 S E D

DEPARTMENT OF THE AIR FORCE  
 AIR UNIVERSITY

**AIR FORCE INSTITUTE OF TECHNOLOGY**

Wright-Patterson Air Force Base, Ohio

89 12 20 058

AFIT/GSM/ENS/89S-30

AN OPERATIONAL SUITABILITY EVALUATION  
TECHNIQUE FOR AVIONICS SUPPORTED WITH  
TWO-LEVEL MAINTENANCE

Thesis

Rodney C. Motley, B.S.  
Captain, USAF

AFIT/GSM/ENS/89S-30

The contents of the document are technically accurate, and no sensitive items, detrimental ideas, or deleterious information is contained therein. Furthermore, the views expressed in the document are those of the author and do not necessarily reflect the views of the School of Systems and Logistics, the Air University, the United States Air Force, or the Department of Defense.

Accountability	
Approved	X
Disapproved	
Reviewed	
Not Reviewed	
Distribution	
Availability Codes	
Special	
A-1	

AFIT/GSM/ENS/89S-30

AN OPERATIONAL SUITABILITY EVALUATION TECHNIQUE  
FOR AVIONICS SUPPORTED WITH TWO-LEVEL MAINTENANCE

THESIS

Presented to the Faculty of the School of  
Systems and Logistics  
of the Air Force Institute of Technology  
Air University

In Partial Fulfillment of the  
Requirements for the Degree of  
Master of Science in Systems Management

Rodney C. Motley, B.S.

Captain, USAF

September 1989

Approved for public release, distribution unlimited

## Preface

The two-level maintenance concept for field support is being considered for many new avionics systems. Decisions must be made early in the development program as to which maintenance concept to pursue. This thesis develops a technique to quantify the operational suitability, in terms of its stated operational requirements, of a system supported with a two-level maintenance concept.

I would like to thank the personnel of ASD/RWW who provided needed insight to the ALE-47 Program. Special thanks go to Ms Kathleen Staub, ASD/RWWL, who provided much of the necessary logistics background information. I would especially like to thank Lt Col James Robinson, my thesis advisor, who guided me through this effort.

Finally, I must thank my family. The patience and understanding shown by my wife Susan and my daughter Molly were probably an effort equal to the thesis. Thanks to my mother-in-law for having them over so much of the time when I needed to work.

Rodney C. Motley

Table of Contents

	Page
Preface . . . . .	ii
List of Figures . . . . .	v
List of Tables . . . . .	vi
Abstract . . . . .	vii
I. Introduction . . . . .	1
Background . . . . .	1
General Issue . . . . .	3
Problem Statement . . . . .	5
Research Objective . . . . .	5
Sub-Objective . . . . .	5
Research Questions . . . . .	6
Limitation of Scope . . . . .	6
Definition of Terms . . . . .	7
II. Literature Review . . . . .	8
Introduction . . . . .	8
AN/ALE-47 Countermeasures Dispenser System . . . . .	8
Current Maintenance Operations . . . . .	11
Two-Level Maintenance Operations . . . . .	12
F-16 Two-Level Initiatives . . . . .	13
Alternative Modeling Techniques . . . . .	15
Simulation Languages . . . . .	19
Summary . . . . .	20
III. Methodology . . . . .	22
Introduction . . . . .	22
Problem Definition . . . . .	23
Data Collection . . . . .	26
Model Development . . . . .	28
Verification and Validation . . . . .	35
Determining Steady-State Conditions . . . . .	36
Experimental Design . . . . .	37
Summary . . . . .	40
IV. Results and Analysis . . . . .	41
Introduction . . . . .	41
Analysis of Means . . . . .	41

	Page
Sensitivity of Means to Shipping	
Frequency . . . . .	48
Analysis of Minimums . . . . .	50
Analysis of Surge . . . . .	54
Effect on Means . . . . .	59
Effect on Minimums . . . . .	60
Analysis of Factorial Experiment . . . . .	62
Summary . . . . .	66
V.    Conclusions and Recommendations . . . . .	67
Summary of Research . . . . .	67
Conclusions . . . . .	68
Recommendations . . . . .	72
ALE-47 System Program Office . . . . .	72
Further Study . . . . .	73
Appendix A: Basic Simulation Model SLAM II Network . . . . .	74
Appendix B: Basic Simulation Model SLAM II Code . . . . .	79
Appendix C: Means from Basic Simulation Model . . . . .	84
Appendix D: Wilk-Shapiro/Rankit Plots for Theater Means and Minimums . . . . .	85
Appendix E: Theater Histograms for Count of Daily Spares Level . . . . .	88
Appendix F: Paired t Test Results for Shipping Time Sensitivity Analysis . . . . .	91
Appendix G: Factorial Design Multiple Regression Output by Theater . . . . .	92
Bibliography . . . . .	94
Vita . . . . .	97

List of Figures

Figure	Page
1. CONUS Average Monthly Spares Histogram . . . . .	45
2. USAFE Average Monthly Spares Histogram . . . . .	45
3. PACAF Average Monthly Spares Histogram . . . . .	46
4. CONUS Minimum Monthly Spares Histogram . . . . .	51
5. USAFE Minimum Monthly Spares Histogram . . . . .	51
6. PACAF Minimum Monthly Spares Histogram . . . . .	52
7. CONUS War Surge Effects on Spares Level . . . . .	56
8. USAFE War Surge Effects on Spares Level . . . . .	57
9. PACAF War Surge Effects on Spares Level . . . . .	58

List of Tables

Table	Page
I. Specification Parameters . . . . .	10
II. Theater Ship Times (days) . . . . .	30
III. Number of Replications Needed . . . . .	43
IV. Theater Statistics (Basic Model) . . . . .	46
V. Confidence Interval Limits (Means) . . . . .	47
VI. Theater Statistics for Various Shipping Times . . . . .	48
VII. Theater Statistics (Minimums) . . . . .	52
VIII. Confidence Interval Limits (Means of Minimums) . . . . .	53
IX. Average Pre and Post Surge Spares Levels . . . . .	59
X. Probabilities of Average Spares Levels Being Greater Than Average Drop . . . . .	60
XI. P Values and Confidence Limits for Average Minimum Spares Levels Being Less Than Average Drop . . . . .	61
XII. Factor Values . . . . .	63
XIII. Factor and Interactions Contributions . . . . .	65

Abstract

The purpose of this study was to develop a technique for evaluating operational suitability of new avionics systems with a two-level maintenance support system. The technique was primarily needed early in the design phases of development programs. The focus would be on could a system meet its operational requirements as set down in program documentation such as the Systems Operational Requirements Document (SORD) with a two-level maintenance concept.

The study had two objectives: develop the technique and demonstrate it on a real system. The AN/ALE-47 Countermeasures Dispenser System was used to demonstrate the technique. A SLAM II simulation model was developed which used operational requirements and three system factors as input parameters. The system factors were reliability, testability, and the initial spares purchase.

Probability distributions were developed for the mean and minimum monthly theater spares level. The average drop in monthly spares level due to the stated war surge was determined. The probability of having enough spares to handle the war surge drop was determined. This allowed quantification of the operational suitability of the system with the two-level concept.

An additional analysis determined the general effects of each of the system factors on the monthly theater spares level through the use of a  $2^k$  Factorial Design. This information aids the user in determining which factors should receive attention to improve the operational suitability of the system with a two-level maintenance concept.

AN OPERATIONAL SUITABILITY EVALUATION TECHNIQUE  
FOR AVIONICS SUPPORTED WITH TWO-LEVEL MAINTENANCE  
CONCEPTS

I. Introduction

Background

Avionics (the electronics onboard aircraft) have become so complex and numerous that a significant portion of the Air Force maintenance structure exists simply to support them. The Air Force implements its maintenance structure in three levels consisting of organizational maintenance at the flight line, intermediate maintenance at a base level shop, and depot maintenance at a central location. From a warfighting capability perspective, there are several disadvantages with the three-level maintenance structure. It generates a large manpower requirement and is vulnerable during a war because of the required facilities and manpower. The maintenance structure must be protected and supported just as the aircraft, weapons, and supplies are. Mobility is an important issue in today's weapon systems since the intermediate maintenance support must be deployed to the conflict area with the weapons. In short, the three-level concept is large, bulky, and ties up airlift resources to move it to the new location, thus diminishing warfighting

capability. The Air Force wanted to improve warfighting capability, and in 1984 came out with the 'R & M 2000' initiative.

The R & M 2000 initiative recognizes the importance of reliability and maintainability of weapon systems to warfighting capability. The initiative requires quantified goals of new systems for:

- A. Increasing warfighting capability.
- B. Increasing survivability of the support infrastructure.
- C. Improving mobility.
- D. Lowering manpower requirements.
- E. Decreasing costs.

These goals are all supported by increasing system reliability, improving fault detection and isolation, and reducing the need for maintenance (11:1).

In response to R & M 2000, an alternative to the three-level concept, the two-level concept is being considered for many avionics systems. This concept eliminates the intermediate level of repair at the base level and alleviates some of the problems associated with the three level concept. Avionics which fail on the aircraft are removed and replaced with spares. The failed units are then shipped directly to the depot for repair. The two-level concept could be a way to streamline the maintenance support structure, providing the system is designed for support in

this manner. In theory, less manpower and support equipment are needed at the base level to support operations. If so, a more efficient, less vulnerable, and more easily deployed weapon system would result. Such a system would support the R & M 2000 goals and increase the Air Force's warfighting capability.

#### General Issue

There are many design decisions which affect whether a system can support flying operations with a two-level maintenance concept. Design decisions involve the system reliability, maintainability, and testability. These decisions generally occur well before the system design is finalized. Air Force personnel and defense contractors would like to know the design factor levels the system must achieve to support flying operations with a two level maintenance concept. No means are currently available for arriving at these levels.

System program office engineers need a tool which will allow rapid and accurate quantification of the effects various levels of reliability, maintainability, and testability will have on the system's capability to support flying operations. Such a tool would link operational requirements and system development parameters, clearly showing the effects of the system's design parameters on operations. Since it is difficult to significantly alter

reliability, maintainability, or testability after the design is finalized, the tool must be utilized early in the system design. However, early in the program, exact information is not always available so the model should utilize the stated operational requirements from the applicable System Operational Requirements Document. The using command provides this document to all programs in the early phases. A tool available early in the program would allow what if analyses to be performed within program and operational constraints.

Another important decision in operational suitability is determining the number of spares to purchase to support the system. This decision is mostly related to program funding, but can be more easily varied system design parameters. Any tool developed should aid the program office in determining the number of spares needed to support the system with a two-level concept.

Cost models exist which develop the costs associated with either a two-level or a three-level maintenance concept. Cost models generally only address the economy and not the effectiveness of the maintenance concept. The lowest cost solution may not always be the best solution in terms of capability to support a system in all scenarios. Maintenance concept effectiveness (or operational suitability) and economy should be considered when making a system support concept decision. Air Force System Program

Office personnel are responsible for making a decision based on the economy and the effectiveness of the system and its maintenance concept.

#### Problem Statement

SPO personnel need the capability to assess operational suitability of proposed maintenance concepts based on system design parameters, operational requirements, and projected spares purchases.

#### Research Objective

The objective of this research is to develop and demonstrate a technique to evaluate operational suitability of proposed maintenance concepts for a new weapon system.

#### Sub-Objective

This technique will be demonstrated on a new weapon system by providing an analysis of a proposed maintenance concept to a System Program Office. The system selected for demonstration purposes is the ALE-47 Countermeasures Dispenser System. The ALE-47 Program Office must decide on a maintenance concept. The office would like to evaluate the operational suitability of the ALE-47 with alternative maintenance concepts before making the decision. The office believes this is an important aspect which must be

considered in the decision. This will demonstrate the technique in the system program office environment.

### Research Questions

The following questions focus the research effort on the information needed to evaluate a system's operational suitability supported by a two-level maintenance concept:

1. Can a probability distribution be developed for the average monthly spares level at each operating location?
2. Can a probability distribution be developed for the minimum monthly spares level at each operating location?
3. What is the effect of wartime surge sortie generation rates on the system?
4. Can the influences of the design factors on the system's operational capability be quantified?

### Limitation of Scope

This research will not attempt to address the issue of cost of the two-level maintenance concept. Life Cycle Cost models exist and are available to the ALE-47 Program Office which can calculate costs for the different maintenance systems. This research will focus on determining whether the subsystem as designed can meet the operational requirements placed on the overall system.

## Definition of Terms

Unfamiliar terms are defined below. These are common operational terms used in the Air Force.

Avionics - electronics carried on aircraft. The avionics discussed in the research will be the ALE-47 Countermeasures Dispenser System.

Break Rate - an operational term reflecting the failures which require immediate maintenance to restore the system to mission capable status. Break Rate is the failure rate of the system derated to a sortie basis. It is equal to one minus the mission reliability for the system (10:14).

Sortie Generation Rate (SGR) - the average number of sorties produced per aircraft in a defined operating day (10:38).

## II. Literature Review

### Introduction

The literature review focuses on general topics relating to the research task. The ALE-47 and its operational requirements are described and discussed. Where and how the ALE-47 fits in with F-16 initiatives toward two-level maintenance is discussed. The two-level maintenance concept is described and contrasted with the three-level maintenance concept which is widely used for avionics today. The use of simulation in research such as this is also discussed. Finally, alternative models which could be utilized in the research are discussed.

### AN/ALE-47 Countermeasures Dispenser System

The ALE-47 Countermeasures Dispenser System is a replacement system for current operational dispenser systems. The program is a response to degraded aircraft survivability caused by more sophisticated threats. A computer controlled, reprogrammable dispenser with the capability to automatically or manually eject chaff, flares and expendable jammers was needed. It was originally conceived to replace the Air Force's AN/ALE-40, but the Navy also needed a replacement for its AN/ALE-39. The Undersecretary of Defense for Acquisition issued a directive to combine the two service's replacement efforts into one

program in November 1986. This single, joint program would satisfy the requirements of both services. In addition, the Army needed a replacement for its M-130 dispenser system so its requirements were added to the program. The ALE-47 will be a common countermeasures dispenser system for all services and should reduce operation and support costs to the Department of Defense (2:4).

Since the ALE-47 will be common to both the Air Force and Navy, the line replaceable units will be essentially the same but arranged in different configurations. One other difference will be present. The Navy uses round expendables and the Air Force uses square expendables. This is handled by a replaceable magazine insert which conforms to the service's expendables (4:61). The Air Force version of the ALE-47 consists of 7 Line Replaceable Units: 1 Cockpit Control Unit; 1 Programmer; 1 Safety Switch; 2 Sequencers; 2 Dispenser Assemblies (2:4). Different magazine assemblies can be inserted into the dispenser assemblies allowing the loading of different sizes and types of expendables. The ALE-47 will be able to sense the different loads carried onboard and upon receiving threat information from other systems, can dispense the proper countermeasure. The system may also be activated manually (2:4-5).

The ALE-47 is being developed by Tracor Incorporated on a four-year full scale development contract from the Air

Force. Tracor Inc. is based in Austin, Texas and is an industry leader in passive countermeasures. The contract price is 15.6 million dollars and includes five production options valued at 77 million dollars (5:105).

Table I outlines the operational requirements for the ALE-47 as stated in the system specification.

Table I. Specification Parameters

Parameter	Value
a. Host aircraft SGR (sorties/aircraft/day)	
Wartime (18 hr day)	
Day 0 to Day 6	3.1
Day 7 to Day 29	2.0
Day 30 and on	1.5
Peacetime (12 hr day)	1.2
b. Sortie Duration (hours)	
Wartime	2.0
Peacetime	1.5
c. False Removal Rate (percent)	1.0
d. Breakrate (percent)	
Wartime	0.195
Peacetime	0.146
e. Mean Repair Time (hours)	
On equipment	0.333

(1:150-151)

The maintenance support concept has not been chosen at this time. The three and two-level concepts are being considered. The program office believes that the ALE-47

could be supported with either but would prefer to recommend the most effective and economical concept.

#### Current Maintenance Operations

The Air Force currently uses a three level maintenance concept for avionics. This concept is efficient, maintaining peacetime readiness at an acceptable level while providing scarce part availability during wartime surge modes. It also gives personnel in the maintenance system the task of repairing items at their particular level. This allows each person to identify with his part in the maintenance process (3:72).

There are some drawbacks to three levels of maintenance. It creates a large and cumbersome system with large manpower requirements. Maintenance manpower requirements can be as high as 1,800 slots for a 72 aircraft fighter wing (6:3). This number includes people at all levels of maintenance. Large numbers of personnel creates a large and vulnerable main operating base which must be protected just as the weapons are. This can tie up valuable wartime assets protecting the air base instead of waging war. To decrease the vulnerability, the Air Force plans to disperse fighter wings into small units, making it harder to find the aircraft (6:3). The drawback with dispersal is that under a three level maintenance policy, maintenance manpower requirements would increase dramatically. Under

today's policy, deploying a squadron of 24 aircraft (based on F-15 and F-16 fighters) requires about 600 maintenance men per squadron (6:3). Simulation of F-16 operations have shown that deploying a wing of 72 into 18 groups of 4 aircraft each could almost double the manpower requirements because of the different, unique skills of the maintainers (6:3). If a two level concept could be implemented the maintenance personnel requirements at the intermediate level could be eliminated which would drastically reduce the manpower requirements for a deployment or a dispersal.

#### Two-level Maintenance Operations

The goal of using a two level maintenance concept is to improve unit mobility and flexibility by reducing manpower requirements. Failed units would be repaired at the aircraft on the flightline or removed and sent to the depot for repair. This should simplify maintenance at the organizational level since only limited repair work could be performed on the aircraft. It should also reduce the airlift requirements during a deployment because no intermediate level support equipment will have to be brought along for avionics repair. The maintenance structure is smaller, less vulnerable, and can be deployed more rapidly (3:72).

The drawback with two level maintenance is the greater dependency on the depot to quickly repair the failed items

and get them back to the operational bases. Airlift will be tied up assuring failed items get to the depot and repaired items get back to the bases. Inventory control will have to be tighter. The system also depends on high reliability of the items removed from the aircraft to cut down on the number of times they are shipped to the depot for repair (3:72). Another dependency is on the ability to properly identify a failed item. Once an item is removed it is sent all the way to the depot before it is checked again to see if it really is failed. If this percentage is too high, sortie generation capability will suffer over time.

One final drawback is the loss of the flightline maintainer's identification with real repair work. The flightline maintainer will simply be removing failed items and sending them to the depot for repair. The feeling of fixing the aircraft will not be as strong as when actual repair work was performed on the system. This effect on personnel will have to be accounted for when considering a two-level concept (3:72). The F-16 Program Office is studying the two-level concept for selected avionics.

#### F-16 Two-Level Initiatives

The F-16 System Program Office has an ongoing Support System Alternatives Study with General Dynamics. The study focuses on the Avionics Intermediate Shop (AIS) of the F-16. The objective of the study is to minimize the AIS through

reliability improvement and reduction of 'cannot duplicates' in the avionics which it supports (12:4). Improving reliability could allow some systems currently supported on the AIS to be switched to a two-level maintenance concept. Reliability goals which allow switching to a two-level concept must be determined. The goals are determined by life cycle repair costs for repairing the avionics at the various levels of repair. The lowest overall cost is assumed to be the optimum level (12:11-12). Cannot Duplicates are defined as items which confirm as failed on the aircraft but upon later testing off the aircraft check as serviceable (12:21). These become even more important in a two-level concept because the off aircraft testing is done at the depot instead of the AIS.

The ultimate objective of this study is to support the R&M 2000 goals. Cost, manpower, and mobility requirements will be reduced by having a smaller AIS. Survivability and combat capability will be improved by avionics improvements and a smaller AIS (12:7).

The ALE-47 would be supported on the AIS if a three-level concept is decided upon. A two-level concept would be more in line with the F-16 initiatives and help to reduce the AIS size. This should only be pursued if effective support can be achieved without reducing warfighting capability. Some modeling technique should be used to determine if capability will be affected.

### Alternative Modeling Techniques

There are several alternative methods to evaluate a two-level maintenance system. The system could be fully implemented and then evaluated. This is not an acceptable alternative because of the risks involved in implementing a system before its capability to support the weapon system has been demonstrated.

Another alternative is the development of a deterministic inventory model which accurately models the system since the maintenance system is basically an inventory system. There are two main assumptions associated with deterministic inventory models. Demand and lead time must be constant (26:682-683). Such a model would not be accurate since neither hold true for a maintenance system.

A stochastic process, such as a Markov Chain, could possibly be used to model the system. A system characteristic which varies with time is observed at discrete points in time in a Markov Chain (26:738-739). Markov Chains require the various states of the model to be independent of time (26:738-739). A Markov Chain could possibly be used to model the system if it remained essentially stationary such as in a peacetime environments. The dynamic behavior the system exhibits during surges could not properly be handled by a Markov Chain.

A simulation model could be used to evaluate the two-level maintenance system. Using simulation overcomes the problem of conducting experiments on the real system. Experimenting with a real system takes more time, cannot be replicated, costs more, and does not allow the extreme conditions to be analyzed safely (20:7). Analytical models of real systems can be developed but the real system is often too complex for the analytical model to accurately predict behavior. Simulation allows a model to be evaluated over time to estimate the model's characteristics through the use of computers (18:1). This allows analysis of a proposed system without actually having to build it before determining its characteristics. There exists a misconception that simulation is simply writing a program and getting results. The methodology of the simulation experiment is just as important as the building of the model itself (18:2).

There are several advantages of simulation. Analytical models often cannot accurately model real systems. Systems can be analyzed under different operating conditions. Alternative designs can be compared without having to build them. Control of the experiment can be maintained when using simulation unlike performing experiments on real world systems and simulation allows the system to be studied for long periods of time without actually having to operate it for that long (18:8).

There are also disadvantages associated with using simulation. Simulation is not cheap and is not always a time saving technique. Simulation is not reality. Only estimates of reality can be obtained from simulation. Often more faith is put in simulation results than is deserved because of the enormous amounts of data generated (18:8-9).

The advantages and disadvantages must be kept in mind when deciding to conduct a simulation study. In the case of the ALE-47, no real system exists right now but a policy must be decided. An estimate of the system's behavior over its operating life before actually fielding it would be very beneficial to the policy decision process. Since maintenance systems are dynamic and must be evaluated under several sets of conditions, simulation appears to be an acceptable method of evaluation.

Once the decision has been made to use simulation, the question arises whether to use an existing model or to build a new one. Dyna-METRIC will be examined as a possible candidate for the research.

Dyna-METRIC was developed by the Rand Corporation to provide information to improve wartime logistics support.

The Dyna-METRIC model was developed to study and predict the readiness of groups of aircraft squadrons as determined by a major subset of logistics resources, namely, those associated with component repair and resupply (15:2).

Dyna-METRIC is a synthesis of analytical and mathematical models with simulation (15:4-5). This allows it to handle

the dynamic behavior exhibited by the system when sortie rates vary (15:4). It breaks the maintenance system down into various sections such as sortie generation, supply, shipping, and repair. These sections are designated as "pipelines" which must be filled with enough spares to allow the system to operate properly (15:3). Calculations are made to determine the number of spares needed to fill the various pipelines (15:30). This measure can be used to develop the spares requirements for the system. The probability of meeting the required missions is also calculated to provide a measure of operational effectiveness (15:37).

"Version 4 of Dyna-METRIC was developed expressly to assess worldwide logistic support of aircraft components, including the depot-theater interactions" (16:1). It relates logistics resources and policies to wartime readiness. It provides a measure of operational performance under the effects of wartime and repair constraints. It also provides problem detection and spares requirements. It is designed to provide three levels of maintenance down to three levels of system repair. The three levels of repair are the Line Replaceable Unit, the Shop Replaceable Unit, and the piece part level. An aircraft is modeled as a collection of LRU's which must all be working for an aircraft to complete its sorties.

There are several assumptions made in Dyna-METRIC which are necessary for it to operate correctly. Repair is unconstrained. Aircraft availability and sortie generation capability are the operational performance parameters provided as output. Lists of problem components, a report of the depot workload, and recommended spares levels are also provided (16:8-10).

Dyna-METRIC does not appear to be suited to this research due to the assumptions which are made in it for operation. It requires much greater input information than is available on the ALE-47. It also does not provide a good measure of the dynamics of the system which is necessary for this study. The best alternative would be to develop a new model optimized for the research task of analyzing a single system which accepts the standard System Operational Requirements Document data as it is provided.

#### Simulation Languages

Once the decision has been made to develop a new model, a simulation language must be selected. The availability of the language, the type of problem, the amount of time available, and the programming effort are all important considerations when selecting a language. Also important is the computer languages which are known by the researcher (18:133). SLAM II is available to AFIT and the ALE-47 system program office on mainframe computers. Its

capabilities are well suited for the research task. Because of these factors, SLAM II on the mainframe computer was chosen as the simulation language for the research effort.

SLAM II is the Simulation Language for Alternative Modeling (21:2). It supports modeling of systems from a variety of points of view. It is capable of discrete event modeling with an event orientation, a process orientation, or both. It is also capable of continuous event modeling. SLAM II allows a pictorial representation of the system to be built using nodes and branches which is important for documenting the model to the ALE-47 Program Office. The nodes and branches are symbols which model elements in a process. Developing a SLAM II model requires combining these symbols into a network which represents the process being modeled. Entities then flow through the network during operation. The network can be built to the level of detail necessary for the simulation study. After the network is built, it is translated for computer execution (21:62-63). Output can be transported to personal computer software packages for analysis.

### Summary

This chapter has provided a review of the current literature on general subjects associated with this research. It presented information on the general system to be modeled, the two-level maintenance system, and on the

specific system, the ALE-47. Alternative modeling techniques were examined and a method selected.

### III. Methodology

#### Introduction

An examination of the operational suitability of the ALE-47 with a two-level maintenance concept is required to fulfill the research objectives. Since the ALE-47 does not physically exist today, a model of the two-level maintenance support structure is needed for evaluation purposes. The previous chapter discussed the two-level maintenance concept and its assumptions. Examination of alternative models revealed that none are particularly well suited for the research task. It was decided to perform a simulation study with a newly developed SLAM II model. The methodology defines the overall approach for model development and the experiments conducted with the model. Law and Kelton outline a ten-step approach to conducting a simulation study which is applicable for this research effort (18:43-46). Other authors, such as Kleijnen (17), Pidd (20), and Pritsker (21) provide similar outlines. The steps are as follows:

1. Formulate the problem and plan the study.
2. Collect data and define a model.
3. Check for validity of the model.
4. Construct a computer program and verify.
5. Make pilot runs.
6. Check for validity of output.

7. Design the experiments.
8. Make production runs.
9. Analyze output data.
10. Document and implement results.

These general tasks must be accomplished to conduct a simulation study. This chapter addresses steps 1 through 8. Chapters IV and V address steps 9 and 10 respectively.

#### Problem definition

An analysis of the operational suitability of the ALE-47 Countermeasures Dispenser System with the two-level maintenance concept is needed for decision purposes. There are two main reasons to use simulation in a study such as this. The comparison of model responses under different conditions is the first and the second is to investigate the relationships between the independent factors and the model's response (17:65). In the case of the ALE-47, both are reasons for conducting the simulation study. Combat capability in peacetime and wartime under various constraints needs to be quantified. The weights of the factors in relation to the response is important for determining possible tradeoffs in case the system does not achieve its warranted requirements or the amount of spares purchased is different from the anticipated.

The ALE-47 SPO must make a decision on which maintenance concept to pursue for the system. Operational

suitability is only one of several criteria to be considered when making such a decision. This study will evaluate the operational suitability of the ALE-47 with the two-level maintenance concept. The results will be used to determine how effectively the concept meets system operational goals. The results of this experiment will provide decision support information in the area of operational suitability to be considered along with other data when making the maintenance concept decision.

Base spares level is the measure of operational suitability chosen for this research. It is defined as the number of spares available on a daily basis at each base. Fighter wings must have minimum levels of spares to be operationally effective. If no spare is available, sorties must be flown without capability of the subsystem. Sorties will not be flown if subsystems on the mission essential subsystem list (MESL) are not operational. There are two mission essential subsystem lists, one for peacetime and one for wartime. Longer duty days and higher sortie rates are required in time of war. The ALE-47 would most likely not be on the MESL in peacetime since it is seldom exercised except for training purposes. However, it may be present on the list in time of war since proper operation of the ALE-47 can greatly enhance aircraft survivability. Its presence on the MESL has not been determined at this time. System utilization would have been implemented as a percentage of

sorties flown for peacetime and wartime but values could not be quantified. It is a program issue that has yet to be settled. System utilization was assumed to be 100 percent since a check of the ALE-47 would be made before each sortie and if a failure was detected, maintenance would be scheduled.

The spares level, as defined above, should be a response to several factors ranging from system design to Air Force policies. Three independent factors have been identified for this study. Reliability, testability, and spares purchase size of the ALE-47 are the three factors.

Reliability is implemented in terms of the system breakrate. Breakrate, as defined earlier, is a percentage of the time a system returns from a mission with a failure. The percentage is based on the exponential failure rate of the system for a set mission duration. The percentage must be recalculated for a change in mission duration.

Testability is implemented as a of percentage of false removals. False removals occur when a unit, thought to be failed, is removed from the aircraft and sent through the repair process. Upon later inspection, the unit turns out not to be failed. This is an additional percentage of the breakrate on a sortie basis.

Spares purchase size is given in terms of a percentage of the production buy. The program office provided 20 percent as a planning figure for the purpose of this study.

## Data Collection

Gathering sufficient information about the proposed maintenance system to allow simulation model development is an important step in the process. A list of the data necessary to develop the model follows.

1. Number of bases, location, and number of aircraft assigned for both peacetime and wartime.
2. Required system operational requirements.
3. Shipping times for failed items from each base to the depot.
4. Incoming inspection rates for items which pass operational status tests.
5. Depot maintenance times for the repair tasks.
6. Quality assurance reject rates for repaired items (those which are still not operational).
7. Shipping times to bases for repaired items.

These inputs will be gathered by using the ALE-47 Use Study (2), the ALE-47 Specification (1), and discussion with program personnel. The logistics manager was consulted as to the correctness of the maintenance system model and to provide any additional logistics data needed. System definition was provided by the system engineer. A walk through of the model was accomplished with the logistics manager and the reliability engineer to determine the validity of the model.

The simulation model is divided into three modules, the sortie generation module, the base supply module, and the depot module. The flying operations and maintenance procedures at each base are modeled in the sortie generation and supply modules. The depot repair process is modeled in the depot module. The two-level model contains the sortie generation, base supply, and depot modules. Discussion of the modules follows.

The sortie generation module models the sortie generation capability in each theater where the system will be used. The system's breakrate is on a per sortie basis and will be used to generate the system failures. Spare LRU's are maintained for each theater. These spares will be used to replace units on the aircraft as they fail. Enough spares must be available to meet the sortie goals.

The supply module will collect the failed LRU's and prepare them for shipping to the depot. The units will await weekly shipping in this module. Failed units will then enter the repair pipeline with its associated shipping time to the depot.

Upon arrival at the depot module, the units will be checked to verify that they are failed. False removals are identified at this point. Falsely removed units will be sent on the depot shipping point to be shipped back out to the bases thus shortening the depot pipeline time. The repair process at the depot will be modeled using the

gathered inputs. Once repaired, the units will be subjected to a quality check to verify they have been repaired. Those failing must go through the repair process again. Those passing will be shipped back to the bases and placed into supply. This is the conceptual framework for the development of the computer model.

#### Model Development

Appendix A contains the SLAM II network for the basic model. Appendix B contains the SLAM II code for the basic model. The network is broken into individual modules and should be referred to during the description of the modules.

The ALE-47 Specification and Use Study outline the operational requirements needed to develop a conceptual model. The program office determined these requirements to be the baseline for any studies conducted, allowing comparison with any other studies conducted. The model needs to be a macro view of flying operations which generate failures in the ALE-47. At this time, the F-16 C/D model is the only aircraft in the Air Force the ALE-47 will be operational on. The F-16 C/D flying operations need to be modeled in accordance with the operational requirements given to the program office. The exact number of F-16 C/D models and their location could not be determined because of classification so a decision was made to use the data provided in the use study pertaining to number of systems

and locations. These values were used in constructing the model. In accordance with the operational requirements, each aircraft flies the same number of sorties of the same length each day. There should be no differences between bases since each has the same number of aircraft as defined by the use study. The only difference between bases is the shipping time to the depot. Mr. T. P. Bramlett, the AN/ALE-40 Item manager at Warner-Robins Air Logistics Center was contacted to provide shipping times for the various bases for the current dispenser system. He stated that there were essentially only shipping times for each theater of operation. There are three basic theaters of operation for the F-16, the continental United States (CONUS), the European theater (USAFE), and the Pacific theater (PACAF). A distribution for shipping time to and from each theater was not known and data was not readily available. Mr. Bramlett stated that the average shipping time for each theater was known along with observed minimums and maximums. Since this data was known, a triangular distribution could be used to quantify the shipping times. A triangular distribution's input parameters are the minimum shipping time, the expected shipping time, and the maximum shipping time. These turn out to be very similar across theaters due to the availability of shipping by air. The shipping times are provided in the Table II.

Table II. Theater Ship Times (days)

Theater	Minimum	Expected	Maximum
CONUS	8	10	30
USAFE	8	12	30
PACAF	8	16	30

(7)

Since all bases are modeled exactly alike and the only difference being the theater ship time, it was decided to model the system in terms of theaters to simplify the model.

From a macro point of view, each theater generates a set number of sorties per day based on the sortie generation rates, the number of aircraft, and the flying hours per day. Since failures are dependent on the total number of sorties, not whether they were flown in singles, pairs, or four-ship formations, it was decided to generate the daily sorties one at a time. Each entity created is a sortie requirement which must be fulfilled. The total number of sorties which must be flown in any theater on a flying day is determined by multiplying the number of aircraft in the theater by the sortie generation rate. The number of sorties which must be launched each hour is determined by dividing the total daily sorties by the flying day length. The time between creation (TBC) of each entity is determined by taking the reciprocal of the hourly launches. This generates the time between sorties on an hourly basis which is necessary for creation of sorties by the simulation model. Sorties are created at

a rate which will satisfy the total daily sorties which must be flown. Each theater's total sortie rate is a global variable whose value can be easily switched at any time point. Different rates were developed for the wartime model. These change the total sortie rate during a war surge.

Total sorties flown is based on a limited flying day. Flying days during peacetime are set at 12 hours in accordance with the operational requirements in the specification (1:150-151). Operations close down for the night after 12 hours. The model handles this with a gate. The day gate in the model is opened for 12 hours and then closed for 12 hours. After an entity is created, the status of the day gate is checked. If day is open the entity continues. If not, the entity is sent to a terminate node.

Peacetime flying days are limited to 260 days per year in accordance with the ALE-47 Use Study (2:8). This works out to a 5 day flying week, 52 weeks per year. The flying week is handled the same as the flying day by the model. The week gate is opened for 120 hours and then closed for 48. The status is checked by each entity before it is allowed to proceed. If open, the entity proceeds. If not, the entity is routed to a terminate node.

If the entity has passed this far through the model unobstructed, it is now a sortie that must be flown to meet requirements. It is assigned a set of attributes which

determine whether it will fail on the sortie, what its shipping time to the depot will be, and whether it will be a false removal. Since failures and false removals are percentages, a uniform random number between zero and one is assigned to these attributes. Shipping time to the depot, from the depot, and the depot repair time are all assumed to be triangular distributions. These are assigned to attributes at this point also. Assigning these values at this point allows repeatability of the runs using the same random number seeds.

Once the entity's attributes have been assigned, it attempts to get an aircraft and fly a sortie. An assumption of the model is that any available aircraft can be used to fly a sortie when demanded. This approximates reality. This allows the sortie rate to be met while some aircraft are down for various reasons including awaiting spares. This also allows the base spares level to be zero and still no sorties lost providing there is time during the flying day to complete all missions. Aircraft are modeled as resources and are assigned to sorties through an await node. This allows any available aircraft to fulfill a sortie requirement. The status of the resource is checked before the entity enters the await node. If there are no aircraft available, the entity is routed through a lost sortie counter and then terminated. The number of lost sorties is collected and provided as output. If an aircraft is

available, it is utilized and departs on a 1.5 hour sortie.

After completion of the sortie, the system is checked for failure. The system breakrate is compared to the uniform random number assigned to the entity just after creation. If the random number is less than or equal to the breakrate, a failure has occurred and the entity is routed to the base supply module. If greater, no failure has occurred and the entity is routed to a free node which frees the aircraft resource to fly another mission. The entity is then terminated.

The base supply module performs two functions. It repairs the break on the aircraft with a spare if available and ships the failed system to the depot. The entity is split down two paths upon arrival. One entity is sent to the shipping await node and the other to the spares await node. If a spare is available the entity proceeds through the node and frees the aircraft resource so another sortie can be flown. If no spare is available, the entity waits in the await node until one arrives from the depot. Shipping occurs once a week on a regular basis. Systems which fail during the week await shipping. Shipping is handled by a gate. The gate is opened once every 168 hours and frees all the entities to be shipped to the depot. The frequency of opening the gate is assigned to a global variable. This allows the shipping frequency to be varied for sensitivity analysis. Entities are assigned a shipping time when

created based on the triangular distribution for the theater in which they reside.

Upon arrival at the depot, a check is performed to see if a false removal has occurred. The false removal rate is checked against a uniform random number assigned earlier. If less than or equal to the false removal rate, the entity has been falsely removed due to testability problems, and is sent directly to depot shipping to be shipped back to the theater. If greater than the false removal rate, the entity proceeds through the depot repair process. The repair process is unconstrained, an assumption that is also made by Dyna-METRIC (16:5). Discussion with Mr. Bramlett, the ALE-40 Item manager, confirmed this assumption. Repair of the current dispenser is basically unconstrained depending on the total depot workload (8). The dispenser's repair is generally basic electronic repair which can be handled fairly easily. Data was not readily available on the repair process but could be modeled with a triangular distribution based on data provided by Mr Bramlett. Repair is done on the average in 26 days, with a minimum of 18 days and maximum of 40 days (8). The repair time is assigned to an attribute upon creation of the entity. Upon completion of repair a quality control check is made to verify the system is operational. A uniform random number is assigned to an attribute and it is checked against a rejection rate of one percent. If the system fails the test, the repair process

is repeated. Upon completion the random number is reassigned and the check made again. The unit may fail again, just as in reality, since repair processes at this level often induce additional failures.

Once the system passes the quality check, it is sent to the depot shipping node where it awaits shipping back to its base. The shipping time is again modeled with a triangular distribution but a different value is drawn for the return shipping time. Once the entity arrives at the theater, it frees a spare resource and then is terminated.

A daily check is made of the spares level at each theater and is recorded in a tabular format for analysis in a spreadsheet or statistics software package.

#### Verification and Validation

A model's validity should be determined with respect to the purpose for which it was constructed. It is valid if it is accurate enough to provide acceptable results for the purpose of the study. Validating a model is part of a simulation study. Validation can take place in a subjective or objective manner and there are many techniques available to do so. The following is a list of techniques (23:33-34):

- A. Comparison to other models.
- B. Degenerate tests.
- C. Extreme-condition tests.
- D. Face Validity.

E. Fixed Values.

F. Predictive Validation.

Law and Kelton outline a three-step approach to validate simulations, consisting of constructing the model with high face validity, empirically testing the assumptions, and determining how representative the output is. High face validity during model construction is obtained by drawing on information from experts, using existing theories and knowledge, and comparing with other models. Flow diagrams of the simulation model were provided to people in the ALE-47 System Program Office familiar with the maintenance system being simulated. As iterations in the model developed and further information was needed, the same personnel were consulted as to the validity of the changes. Large, complex models exist which simulate maintenance systems. Dyna-METRIC is an example of such a model. Its documentation was reviewed to aid in proper development of the model. The ALE-47 System Program Office determined this is a valid model for the ALE-47 two-level concept. Since the model was accepted as valid for the study, experiments could be designed to answer the research questions.

#### Determining Steady-State Conditions

The initial starting conditions can bias the output from a simulation. The period of time necessary for the daily spare level in each theater to settle down to steady

state must be determined to eliminate biases in the output data due to the transient period. There are two basic approaches to eliminate this bias. A warm-up period can be used or the typical starting conditions can be input as the initial conditions (20:161). Determining typical starting conditions for this system was difficult so a warm-up approach was chosen. There are no easily implemented methods for determining the length of the warm-up period (20:161). This will be accomplished by plotting and comparing spares level as time advances over several pilot runs. Eight pilot runs of 5 years length were performed and plotted. A comparison was made across the eight runs to determine the transient phase. In all cases it was apparent steady state had been achieved by 4000 hours (about six months of simulated time). As a safety measure, it was decided to extend the run-in length to one year (8760 hours). Any transient effects should be overcome by this point.

#### Experimental Design

There are four experiments in the study which attempt to answer the research questions. The first is to develop a probability distribution for the monthly mean spares level for each theater. The second is to develop a probability distribution for the monthly minimum spares level for each theater. The third is to determine the effect of going to

war with its increased sortie rates on the spares level of each theater. The fourth is to determine the weights of each factor in determining the response.

Experiments one and two can be conducted from the same set of runs. Thirty independent samples of spares level for each theater over a thirty day period will be collected as output data. For experiment one, each sample's theater daily values will be averaged to provide a mean for each theater for each sample. The means will be used to develop a probability distribution for the mean spares level for each theater for a thirty day period. 95 percent confidence limits will be placed on the distribution. This will allow the theater mean spares level in a thirty day period to be stated within the confidence limits.

For experiment two, the same data can be utilized with the minimum value from each theater in each sample being identified. Theory states that extremes are known to follow one of three non-normal limiting distributions (9:199). Theory also states that minimums (the smallest extremes) are known to follow the Weibull distribution (9:200). The thirty minimum values from each of the theaters will be used to build a distribution which will be tested against the Weibull distribution. Ninety-five percent confidence limits will be placed on the distribution. If the distribution holds, this allows the theater minimum spares level in a thirty day period to be stated within the confidence limits.

If the distribution cannot be stated, nonparametric methods will be used for analysis of the minimums.

Experiment three will attempt to quantify the effects of the wartime surge. The average amount of time it takes the system to settle down to a new steady state will be determined in addition to the drop in the average daily spares level. The daily spares level will be collected throughout the length of the run. Several runs will be made. An average level for a thirty day period in peacetime just before the war surge will be collected. A similar average level for a thirty day period after wartime steady state has been reached will be collected. These two averages will be used to quantify the drop in average daily spares level for a thirty day period. The time taken to settle into a wartime steady state will be averaged across the runs. These two measures will be used to quantify the effects of the wartime surge on the system.

A full  $2^k$  factorial design will be used to determine the relative effects the three input factors have on sortie generation capability in experiment four. The  $2^k$  experimental design varies each factor at two levels and since there are three input factors this will require eight separate runs replicated several times. Comparison of the outputs will allow quantification of the effects of each factor on the spares level. In addition, the effects of interaction between the factors on spares level can be

determined from the full factorial design (14:116). The effects of each factor and the interactions will be tested for significance. This data can be used for tradeoff analyses between the factors if one does not achieve its projected level. The data will also prove useful if other program parameters change and force changes in these factors.

### Summary

This methodology provides the basis of a technique to evaluate the operational suitability of the two-level maintenance concept for systems which are still under development. The results of this experiment provides operational suitability information to the ALE-47 Program Office for use in their maintenance concept decision. It allows them to predict the minimum and average spares levels for a thirty day period. The effects of the wartime sortie rates and of each factor on the spares level can be quantified for the system. This methodology does not provide a generic model but does provide a framework which can be customized for any system under development.

## IV. Results and Analysis

### Introduction

This chapter describes the results obtained by using the model and conducting the experiments outlined in the previous chapter. The methods used to analyze the results are discussed with the results. In each experiment, it was necessary to achieve steady-state conditions before collecting data. It was also necessary to obtain independent observations. The methods described in the previous chapter were used to fulfill these requirements. Each experiment is discussed in the order performed.

It should be noted that no sorties were lost due to inadequate spares in any of the simulation runs. The theaters were all capable of the sortie generation rate. A run with a failure rate high enough to cause a failure every flight was made to verify that the lost sortie counter was operating properly. The data confirmed the counter was operating properly. The assumption that any aircraft available can fill the sortie requirement appears to be the reason no sorties were lost.

### Analysis of Means

The average monthly spares available in each theater after the system is in steady state is of interest since the ability of a unit to wage war depends on its available

supplies. Characterization of the average monthly spares level provides one measure of the operational suitability of the system with the two-level maintenance concept. A 95 percent confidence interval will be developed around the average monthly spares level for each theater under peacetime operating conditions.

Thirty replications of the basic model were made. Each replication resulted in data which consisted of one month (30 days) of daily observations of each theater's spares level. Each replication's data points were averaged to produce a mean for each theater for that particular replication. The result is thirty means for each theater. Each theater's means were analyzed separately. The means are listed in Appendix C. The central limit theorem states that

if random samples of  $n$  measurements are repeatedly drawn from a population with a finite mean  $\mu$  and a standard deviation  $\sigma$ , then, when  $n$  is large, the relative frequency histogram for the sample means (calculated from the repeated samples) will be approximately normal (bell-shaped) with mean  $\mu$  and standard deviation  $\sigma/\sqrt{n}$  (19:109).

Assuming independent data was generated as discussed earlier and using the central limit theorem, the data should follow the normal distribution. To verify that 30 replications were enough to satisfy confidence requirements, Equation (1) was used.

$$R / r = ( d / D )^2 \quad (1)$$

where R equals the number of replications needed for the desired confidence, r equals the number of pilot replications performed, d equals the confidence interval width calculated from the pilot runs, and D equals the desired confidence interval width (22). The pilot run confidence interval width, d, is calculated using a t statistic confidence interval. The estimate of the mean standard deviation, produced by the pilot run, is multiplied by the t value for the confidence desired and the number of replications. This value is subtracted from the mean to produce the lower confidence limit and added to the mean to produce the upper confidence limit. The difference between the limits is the confidence interval width. The desired confidence interval width was chosen to be 4 or plus or minus two spares. The number of replications necessary to obtain a 95 percent confidence interval on the means of each theater are given in Table III.

Table III. Number of Replications Needed

Theater	Number of Replications
CONUS	29.7
USAFE	27.1
PACAF	10.4

Halving the desired confidence interval width to 2 requires over 100 replications for the CONUS and USAFE theaters. A confidence interval width of 4 is reasonable for this study.

so it was decided not to expend additional computer time and resources for a smaller confidence interval width.

To graphically portray the shape of the data, a frequency histogram was generated for each theater's mean monthly spares level. The histograms are displayed in Figures 1, 2, and 3.

Just reviewing the frequency histograms for a bell shape does not constitute a test for the normal distribution. Additionally, the data was checked for normality using the Wilk-Shapiro/Rankit Plot (24:8.4). In the Wilk-Shapiro/Rankit Plot, the sample values are reordered according to their rank to generate order statistics. The expected value of each order statistic is defined as its "rankit". The rankits follow the normal distribution with mean 0 and variance 1. The rankits are then plotted against the order statistics. If the sample follows the normal distribution, the plot should show a linear trend with only slight random error (24:8.5). The Wilk-Shapiro/Rankit Plots for each theater are shown in Appendix D. Each theater's plot indicates the normal distribution is an acceptable distribution for the mean monthly spares level as was expected by the central limit theorem.

The means and standard deviations for each theater are listed in Table IV. The mean for each theater is the average of the mean from each replication. The standard

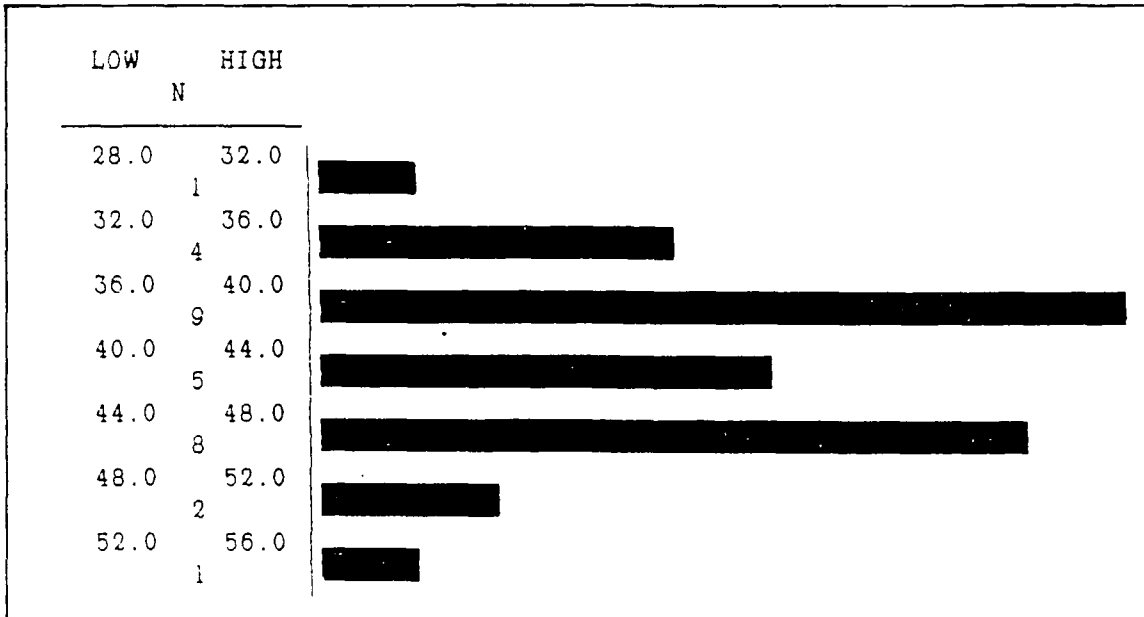

Figure 1. CONUS Average Monthly Spares Histogram

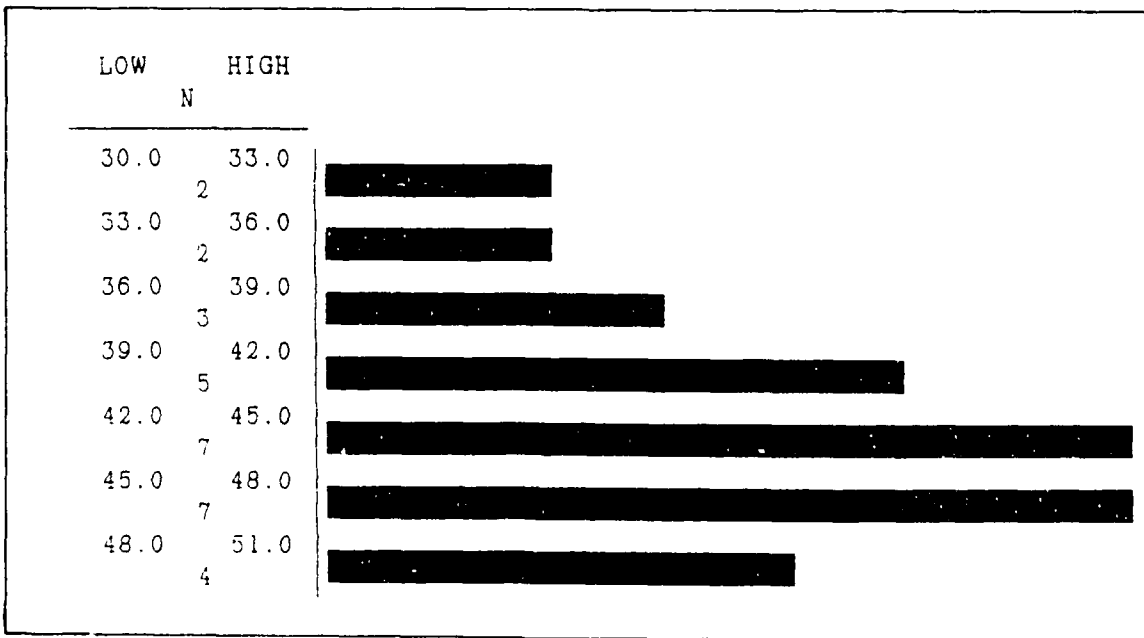

Figure 2. USAFE Average Monthly Spares Histogram

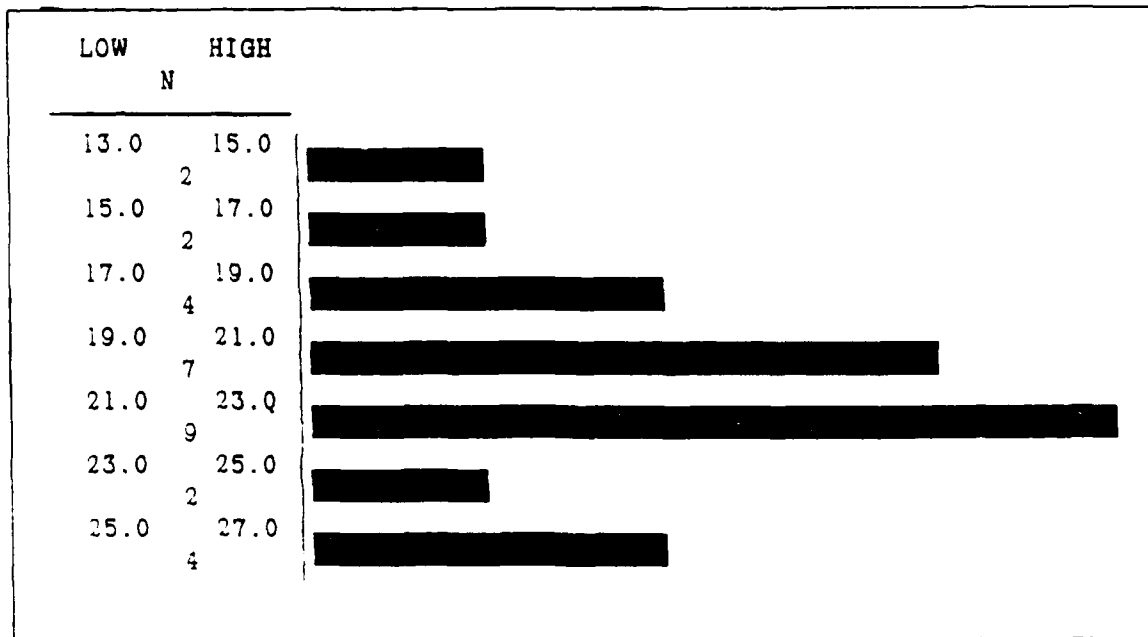

Figure 3. PACAF Average Monthly Spares Histogram

deviation of the mean is the sample standard deviation divided by the square root of 30, the number of samples.

Table IV. Theater Statistics (Basic Model)

Theater	Mean	Standard Deviation
CONUS	41.37	0.9742
USAFE	42.56	0.9289
PACAF	20.79	0.5753

An additional run of 10 years in length was made. A check of the normality of the system can be made by plotting the number of days a particular spares level was observed over the length of the run. The first year's data was dropped

from the analysis as before due to system warm-up time. The frequency histograms for each theater are shown in Appendix E.

Since it can be assumed that the distribution of the mean of the spares levels in each of the theaters follows the normal distribution, a confidence interval can be constructed around the mean. This will be used to quantify the true monthly mean spares level within limits. A 95 percent confidence interval was chosen for the experiment. The upper and lower confidence limits are given by Equation 2.

$$(y - 1.96\sigma , y + 1.96\sigma ) \quad (2)$$

where  $y$  is the observed sample mean and  $\sigma$  is the sample standard deviation. Table V summarizes the confidence limits at the 95 percent confidence level for each of the three theaters.

Table V. Confidence Interval Limits (Means)

Theater	Lower limit	Upper limit
CONUS	39.46	43.28
USAFE	40.74	44.38
PACAF	19.66	21.92

The analysis was performed under peacetime conditions and indicates the average monthly spares level should adequately support operations in each theater.

The confidence interval about the mean for each theater is important in determining the operational suitability of the two-level maintenance concept since the number of spares available significantly impacts the warfighting capability of an operational unit. The average number of spares expected to be in any theater in any given month can be an important planning tool.

Sensitivity of Means to Shipping Frequency. Since the frequency of shipping from each theater and to each theater could not be accurately quantified, a sensitivity analysis was conducted by varying the frequency of shipping in the model. Two additional runs were made of thirty replications each using the same data collection scheme. In the first run, shipping occurs every two days from each theater and from the depot. In the second, shipping occurs every fourteen days. The means and standard deviations from the runs for each theater are listed in Table VI.

Table VI. Theater Statistics for Various Shipping Times

Ship Time	Theater	Mean	Standard Deviation
2 days	CONUS	44.81	0.6452
	USAFE	43.68	0.8873
	PACAF	21.41	0.6648
14 days	CONUS	38.65	0.9848
	USAFE	37.73	0.8451
	PACAF	18.58	0.4172

To determine if there is a significant difference from the seven day shipping frequency assumption used in the basic model, a paired sample t-test was used twice. The comparison was made between the two and seven day models and the seven and fourteen day models. The null hypothesis in both tests was that the difference between the two means was equal to zero. The alternate hypothesis is that the difference between the means is not equal to zero, thus implying that there is some significant difference between the means. The confidence level for this test was 95 percent. The test statistic is defined by Equation (3).

$$t = d / (s/\sqrt{n}) \quad (3)$$

where d is the difference between the means, s is the standard deviation of the differences in the means, and n is the number of means (19:196). The software package STATISTIX was used to perform this test. The results are showed significant differences in the differences of the means for all combinations except USAFE and PACAF between the seven and two day models. The results are stated in Appendix F. For the purposes of this study, the seven day model results will be used. There are other simplifying assumptions employed in the model so this should be acceptable. Any additional studies should characterize the shipping frequency more accurately if possible.

The mean monthly spares level is only one measure of operational suitability, however. Another measure of

operational suitability which may be equally important is the minimum monthly spares level in each theater.

#### Analysis of Minimums

The average spares level for any theater appears to be a good measure of suitability but since the Air Force would like to be always ready to go to war the monthly minimum spares level would be of more interest in order to plan for all contingencies. Theory states that minimums follow the Weibull distribution, but the Weibull can assume the shape of many other distributions including the normal and exponential (13). The same data used in the analysis of means is used in the analysis of the minimums. The minimum value from each theater in each replication was identified. The thirty minimums for each theater then constituted the data set for analysis. First, a frequency histogram for each theater was constructed to graphically portray the distribution shape. The three histograms are shown in Figures 4, 5, and 6. The underlying distribution of the minimums is not apparent from the histograms. The minimums from each theater were tested for conforming to the Weibull distribution using the Kolmogorov-Smirnov Test in AID, the SLAM II data analysis package. Each set of data accepted the hypothesis that the data followed the Weibull. Additionally, the Wilk-Shapiro/Rankit Plot was used to check for normality. The Rankit Plots for each theater are shown

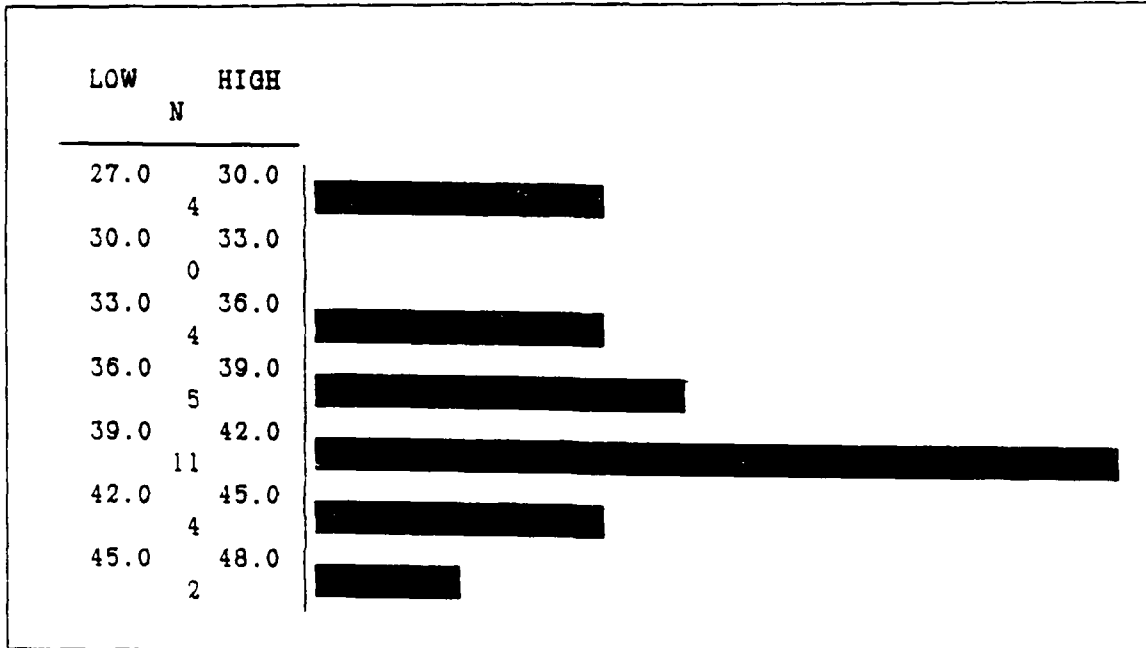

Figure 4. CONUS Minimum Monthly Spares Level

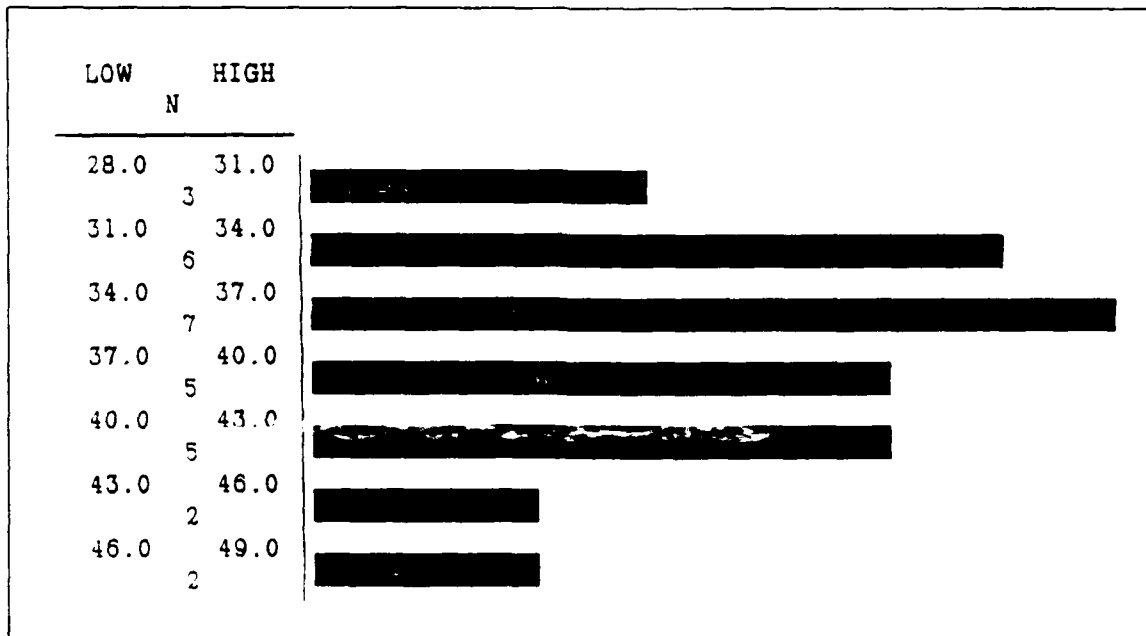

Figure 5. USAFE Minimum Monthly Spares Level

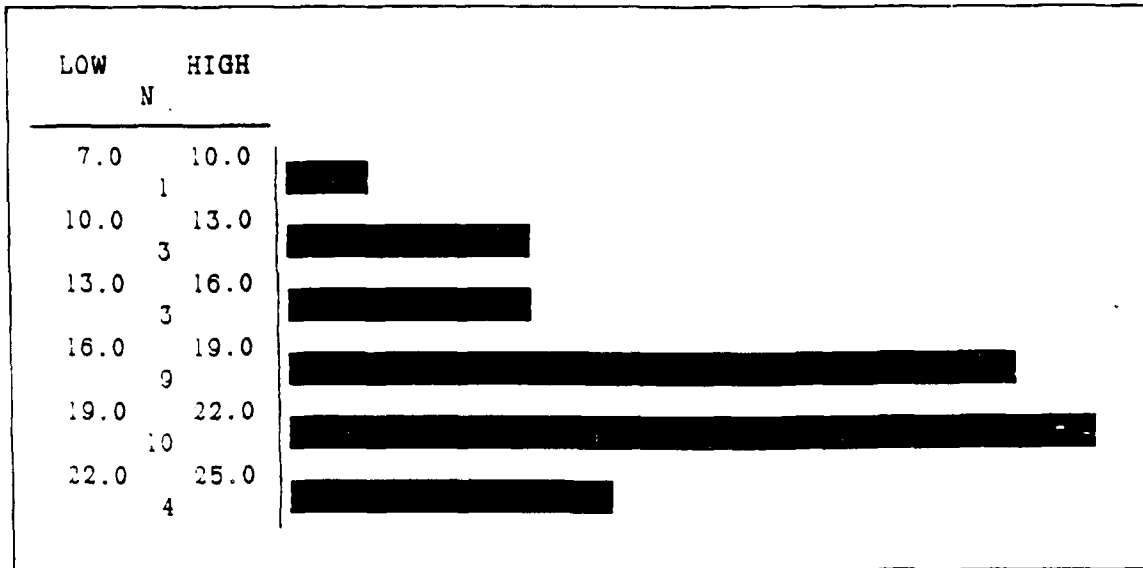

Figure 6. PACAF Minimum Monthly Spares Level

in Appendix D. In all three theaters, the plots indicate the normal distribution is also a possible model. If the minimums follow the normal distribution, means and standard deviations for each theater can be calculated. Table VII summarizes the means and their standard deviations of the minimums for each theater.

Table VII. Theater Statistics (Minimums)

Theater	Mean	Standard Deviation
CONUS	37.63	0.996
USAFE	39.20	0.919
PACAF	18.47	0.711

These represent the expected value of each theater's monthly minimums. If the normal is assumed, a 95 percent confidence interval can be developed around each theater's mean in order to make statements about the mean monthly minimum spares level. The confidence interval is given by the formula  $(y - 1.96\sigma, y + 1.96\sigma)$ . Table VIII summarizes the 95 percent confidence intervals for each theater.

Table VIII. Confidence Interval Limits  
(Means of Minimums)

Theater	Lower Limit	Upper Limit
CONUS	35.68	39.58
USAFE	37.40	41.00
PACAF	17.08	19.86

It should be noted that zero does not fall within any of the intervals even at the 95 percent confidence level. This implies that the chances of the spares level being zero is very small in each of the theaters.

Since the minimums passed tests for different underlying distributions, it is possible the data set is too small to accurately determine the distribution. Any analysis performed with this data should employ nonparametric statistics since the underlying distribution cannot be accurately determined.

## Analysis of Surge

Peacetime represents a fairly stable environment for the operation of the ALE-47, but wartime changes the aircraft sortie rates significantly. The higher sortie rates cause system failure more often and cause the whole maintenance system to settle to a new mean level in each theater. The objective of this experiment is to quantify the change in the mean spares level from peacetime flying rates to wartime surge rates. The change is examined in two dimensions. The first is the average drop in the mean spares level from peacetime to wartime. The second dimension is the amount of time necessary for the system to settle down to a steady mean spares level.

An additional module was added to the basic model which started the war surge after one year (8760 hours). It changed the sortie rates for each theater to the war surge rates stated in the specification. To accurately quantify the drop, the number of spares available in each theater was set to 100 percent in these runs of the model as opposed to 20 percent, the proposed rate. This precludes the chance that the surge drop would cause the level to drop to zero or below. Since the model does not collect values below zero, it would be impossible to quantify the drop if it went below zero. Starting with 100 percent spares allows the effects of the surge to be quantified by dropping from an average presurge level to an average post surge level. The

parameter of interest is the amount of the drop, not the pre and post levels themselves. The data collection scheme was changed to record daily values of each theater's spares level. The daily values for the five runs were averaged to produce an average daily spares level for each theater. Plots showing the effect of the war surge on each theater follow in Figures 7, 8, and 9.

The presurge average theater spares level is calculated using the daily spares levels observed from 4000 to 8760 hours. The war surge commences at the 8760 hour point. Each theater's plot is examined to determine an approximate point in time at which a new steady state is achieved. In the CONUS theater, the graph indicates post surge steady state is achieved at approximately the 11,500 hour point. A postsurge average spares level was calculated with the data from that point to the 20,000 hour point which ends the simulation run. This postsurge level is then subtracted from the presurge level to develop an average drop due to the war surge for each theater. CONUS restabilization occurs at approximately 11,500 hours which equates to approximately 113 days. This is the number of days necessary for the system to stabilize into steady-state at the new sortie generation rate of 1.5 sorties per aircraft per day. The stabilization point for USAFE is approximately 11,100 hours. This equates to approximately 98 days from the start of the surge. The PACAF stabilization point occurs at approximately 11,600 hours. This equates to

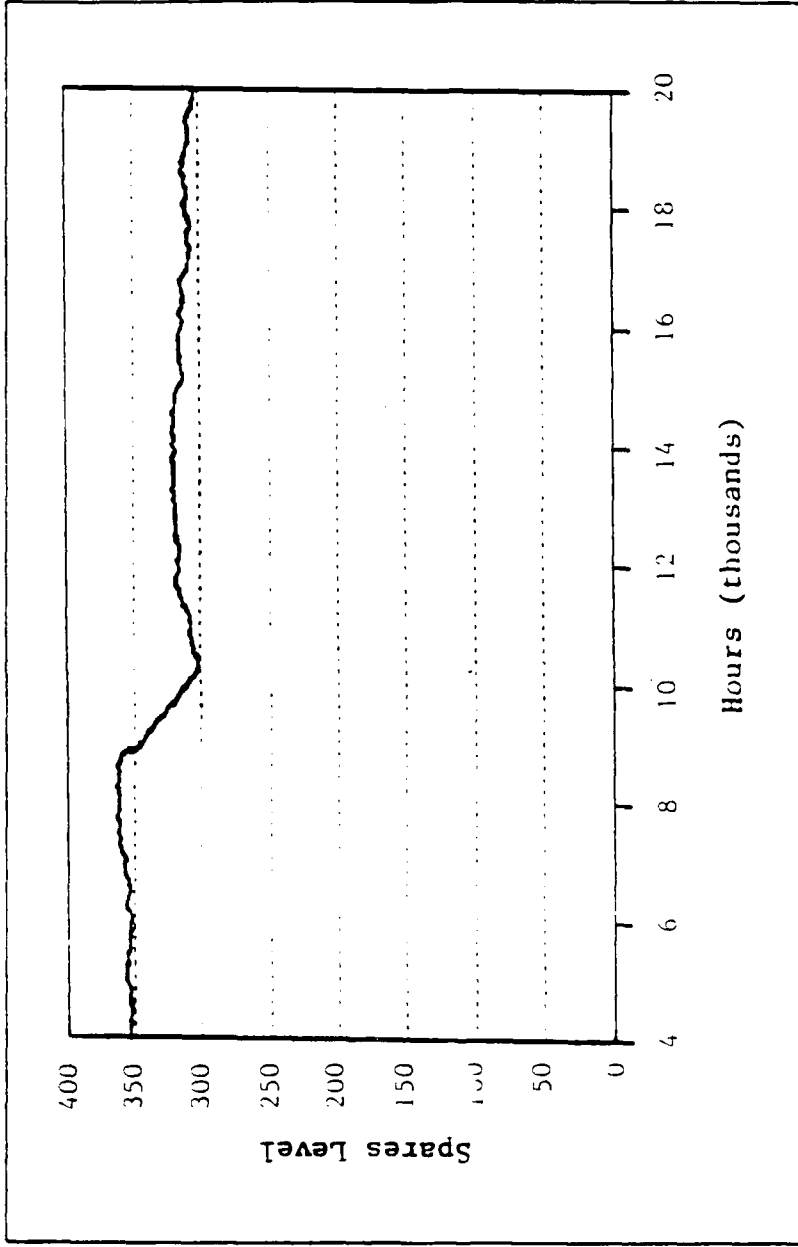

Figure 7. CONUS War Surge Effects on Spares Level

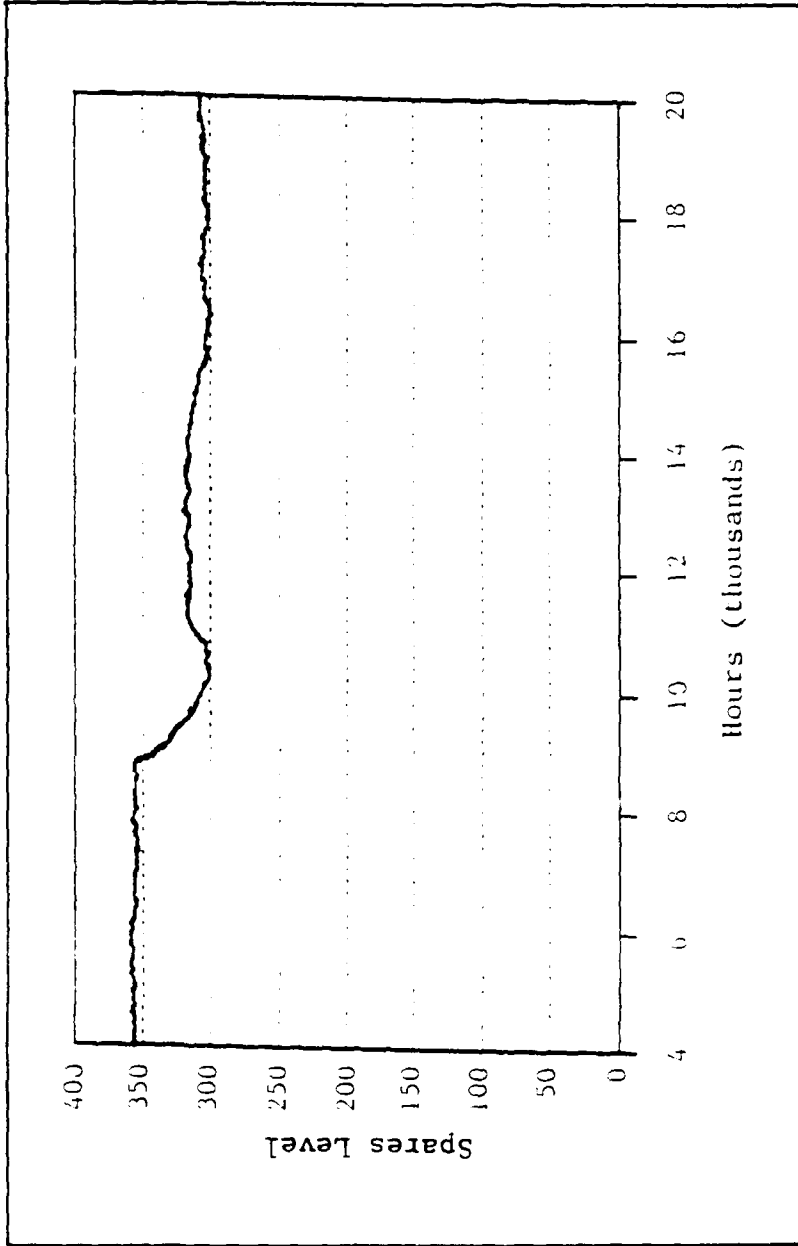

Figure 8. USAFE War Surge Effects on Spares Level

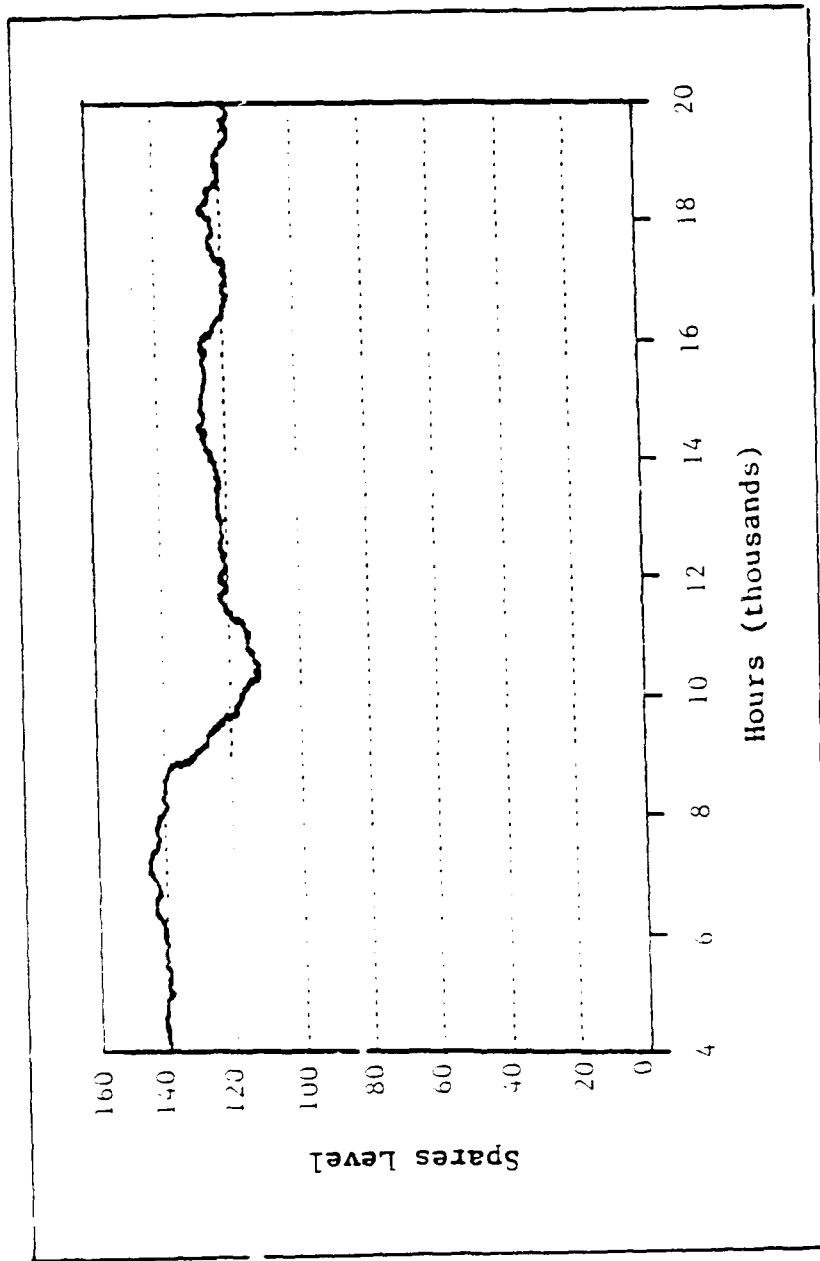

Figure 9. PACAF War Surge Effects on Spares Level

approximately 118 days. Table IX provides the pre and post surge average spares levels for each theater as well as the average drop in spares level for each theater.

Table IX. Average Pre and Post Surge Spares Levels

Theater	Presurge	Postsurge	Average Drop
CONUS	357.26	314.48	42.78
USAFE	356.88	310.34	46.54
PACAF	141.32	122.85	18.47

Effect on Means. Applying the average drop to the average monthly spares level in peacetime indicates shortages may occur providing no other parameters which affect the spares level are changed. Since the underlying distribution of the average monthly spares level in each theater was determined to be normal, Z scores were used to determine the probability of the average monthly spares level being greater than the average drop expected in the war surge. Z values were calculated for the drops in each theater using equation (4)

$$Z = (\mu - y) / \sigma \quad (4)$$

where Z is the calculated Z score to be looked up in a table,  $\mu$  is the sample mean for each theater, y is the average drop for that theater, and  $\sigma$  is the standard deviation of the mean for that theater. Z tables provide the probabilities which correspond to those values. The portion underneath the probability curve which is greater

than the Z value constitutes the probability of the monthly spares level for that theater being greater than the average drop. Table X summarizes the probability of the average monthly spares level being greater than the average drop calculated for the theater.

Table X. Probabilities of Average Spares Levels Being Greater than Average Drop

Theater	Probability of Mean Spares Level > Drop
CONUS	.395
USAFE	.217
PACAF	.769

Effect on Minimums. Since the underlying distribution of the minimums could not be accurately determined, a non parametric approach was used to evaluate the effects of the surge given the monthly spares level is near its minimum level. The purpose of this analysis is to predict the percentage of the values which are less than a certain value. This can be done using the binomial distribution. Binomial data is characterized by either being in a specified interval or not. The chance it will fall in the specified interval is defined as p. An estimate of p must be obtained. The number of values in each theater which were less than the average drop for that theater were counted. This number was divided by the number of observations in each theater. The number of observations in

each theater is thirty in this study. This division provides an estimated p value which can be used to develop a probability. Welch states that if  $Mp(1-p) > 9$ , the normal approximation to the binomial may be used (25:287). He also states, "this rule may be too conservative for some simulation work (25:287)." Ott states that if  $np < 5$  or  $n(1-p) < 5$ , the normal approximation to the binomial may be unsatisfactory (19:117). Formulas for the calculation of upper and lower p values within confidence limits are also given in Welch (25:287). The p values and their lower and upper limits are given in Table XI.

Table XI. P Values and Confidence Limits  
for Average Minimum Spares Levels  
Being Less than Average Drop

Theater	Lower	p Value	Upper
CONUS	0.613	0.800	0.812
USAFE	0.813	0.967	0.980
PACAF	0.292	0.467	0.479

These values represent the probability of not having enough spares to handle the average war surge drop if the spares level is at the average minimum value. This indicates that the ability of the theaters to surge in any given month can be severely limited by the system when at minimum values.

In order to characterize the drop due to the surge, it was decided to continue to fly the same number of aircraft

in each theater at the higher rates. In reality, planes from the CONUS would most likely deploy to the theater of conflict. The surge may be looked at as just a training exercise also. This point of view would allow the aircraft to remain in their normal operating theater. Some other items which would definitely affect the spares level in a real conflict would be aircraft attrition, production of additional spares for war, and speeding up of the shipping and depot repair times.

#### Analysis of Factorial Experiment

The full factorial experiment is used to examine the contribution of each factor and the interactions between them in determining the average monthly spares level in each theater. To generate the data for analysis, eight separate runs are made with the factors varied on a high and low basis. Thirty replications of each run were made. Each run has specific high and low value for reliability, testability, and spares purchase. Table XII lists the values for each factor in each of the runs. The high and low values for each are marked with + and - signs respectively.

Table XII. Factor Values

Run Number	Reliability	Testability	Spares Level
1	.000803 (+)	.01 (+)	10% (-)
2	.000876 (+)	.20 (-)	10% (-)
3	.000803 (+)	.01 (+)	30% (+)
4	.000876 (+)	.20 (-)	30% (+)
5	.002949 (-)	.01 (+)	10% (-)
6	.003504 (-)	.20 (-)	10% (-)
7	.002949 (-)	.01 (+)	30% (+)
8	.003504 (-)	.20 (-)	30% (+)

Low numerical values of reliability and testability are actually higher levels of the factors because of the way they are incorporated in the model. Higher reliability is modeled with a lower breakrate and higher testability with a lower false removal rate.

Using these values, simulation runs were made and average monthly values for each theater were calculated using the same procedure as in the analysis of means. These average values were then used to calculate the contribution of each factor toward the average monthly spares level. Equations 5-11 describe how the contribution of each factor is calculated.

$$R = (1 + 2 + 3 + 4 - 5 - 6 - 7 - 8) / 4 \quad (5)$$

$$T = (1 + 3 + 5 + 7 - 2 - 4 - 6 - 8) / 4 \quad (6)$$

$$SL = (3 + 4 + 7 + 8 - 1 - 2 - 5 - 6) / 4 \quad (7)$$

$$R/SL = (3 + 4 - 8 - 7 - 2 - 1 + 5 + 6) / 4 \quad (8)$$

$$R/T = (6 - 2 + 8 - 4 - 5 + 1 - 7 + 3) / 4 \quad (9)$$

$$T/SL = (6 + 2 - 8 - 4 - 5 - 1 + 7 + 3) / 4 \quad (10)$$

$$R/T/SL = (2 + 8 - 6 - 4 + 5 - 1 - 7 + 3) / 4 \quad (11)$$

where R is reliability, T is testability, and SL is the spares purchase size. The terms with slashes indicate the interactions between two or more of the factors. The numbers within the parentheses represent the simulation run number. The summation and subtraction of the runs represents the differences in the planes formed in space. The result is divided by four because the result represents the summation of differences at four points in space. The contributions of each of the factors and the interactions across each theater are summarized in Table XIII.

Table XIII. Factor and Interactions Contributions

Factor	CONUS	USAFE	PACAF
R	35.15	36.17	16.39
T	1.89	2.59	-0.48
SL	58.72	58.25	30.36
R/SL	15.72	16.06	5.45
R/T	-2.70	-1.79	-0.61
T/SL	2.01	1.84	-0.03
R/T/SL	-2.57	-2.54	-0.16

These contributions can be utilized as  $\beta$  coefficients to develop a regression equation that predicts the average monthly spares level. In this case, the program office would like to know approximately the relative contribution of each factor for planning purposes. The amount of spares purchased appears to have the greatest positive effect on the average monthly spares available in each theater. Reliability is the second most important, followed by the interaction between reliability and spares purchased. To test the significance of each of the effects, a multiple regression model which included all of the factors and their interactions was proposed. The software package STATISTIX was used to run a multiple regression on this model. The input values for each of the factors and the interactions was either a negative one (-1) or a positive one (1). These values represent the high and low values used on each of the factorial simulation runs. A matrix was developed for each theater which included the response from each run and the associated factor and interaction values for that run

(17:315-317). STATISTIX provides a t test for each of the factors and interactions significance. The results for each theater are provided in Appendix G. The results showed slight differences in the PACAF model verses the other two. In PACAF, four factors were determined to be insignificant. They were Testability, the Reliability/Testability interaction, the Testability/Spares Purchase interaction, and the Reliability/Testability/Spares Purchase Interaction. Only Testability was borderline insignificant in the other two theaters.

#### Summary

This chapter presented the four experiments which were used in the research. The procedures to produce the data and analyze the data were discussed. Assumptions were verified and results stated for each experiment. The results will be used to draw conclusions and make recommendations to the program office. The results will also be used as a basis for recommendations for further study. Chapter Five will discuss how the results support the research objectives and questions.

## V. Conclusions and Recommendations

### Summary of Research

The objective of this research was to develop and demonstrate a technique to evaluate the operational suitability of proposed maintenance concepts for new avionics systems. The system chosen for demonstration purposes was the ALE-47 Countermeasures Dispenser System. The four research questions focused on developing probability distributions for average and minimum spares levels, quantifying the effect of the war surge on those levels, and quantifying the effects of the design factors on the operational suitability of the system.

A simulation model was developed in SLAM II which used as input the operational requirements of the system as stated in the specification. Approximate numbers of aircraft and spares were used based on program information. The reliability levels stated in the warranty were used for field reliability.

Probability distributions were developed for the average monthly spares level and minimum monthly spares level in each theater. The effect of the war surge in each theater was determined in terms of the average drop in spares level and the length of time necessary for the system to settle down into steady state conditions after the surge.

A full factorial experiment was used to quantify the contribution of each factor to the average monthly spares level in each theater.

### Conclusions

The average monthly spares level for each theater can be described with a normal distribution. A mean and standard deviation was developed for the distribution with confidence limits placed around the mean. The average number of spares for a month can be quantified with this value for each theater. These values give an indication of the operational suitability of the system with the two-level maintenance concept. These by themselves are not a complete view of the operational suitability since the average is just that, an average. Maintenance personnel are most interested in the chance of running short of spares. This is tied more closely to the minimum value observed in a period of time.

Theory states that minimums follow the Weibull distribution. In this study the minimums passed tests for both the normal and weibull distributions. The Weibull distribution can take the form of a normal distribution so the theory may still be accurate. The minimum values were significantly lower than the average values and should be used for a worst case analysis of warfighting capability. The average and the minimum values only give an indication

that normal peacetime operations with the two-level maintenance concept do not unduly tax the available spares. Since these were developed under peacetime conditions, an important measure is what effect these peacetime levels have on the warfighting capability.

The war surge caused a significant average drop in spares level from peacetime to wartime in each theater. Applying the average drop to the average monthly spares level in peacetime indicates shortages may occur providing no other parameters which affect the spares level are changed. Since the underlying distribution of the average monthly spares level in each theater was determined to be normal, Z scores were used to determine the probability of the average monthly spares level being greater than the average drop expected in the war surge. Table X in Chapter IV summarized the probability of the average monthly spares level being greater than the average drop calculated for the theater. The values ranged from 0.217 in USAFE to 0.769 in PACAF.

Since the underlying distribution of the minimums could not be accurately determined, a non parametric approach was used to evaluate the effects of the surge given the monthly spares level is near its minimum level. The p values and their lower and upper limits are given in Table XI in Chapter IV. The probabilities range from 0.457 in PACAF to 0.967 in USAFE.

These values represent the probability of not having enough spares to handle the average war surge drop if the spares level is at the average minimum value. This indicates that the ability of the theaters to surge in any given month can be severely limited by the system when at minimum values. It should be noted that the analysis is a simplified worst case scenario. There are many additional factors which are not included in this analysis. In the case of an actual war in one theater, additional aircraft and spares would be deployed. Aircraft attrition would have to be factored in along with aircraft being down for other reasons such as battle damage and other critical systems down. The repair pipeline would most likely be accelerated and perhaps even additional spares purchased to support a war. The factors could not be quantified for this research but should be considered when assessing the warfighting capability. This research looked at the situation as a worst case analysis. This is done by assuming that aircraft are always available except for the ALE-47. If it is down, the aircraft is down. This is not the case in reality, but was used in this study for two reasons. First, the program office has no control over the rest of the aircraft and are only concerned with the ALE-47. Second, the breakrate of the ALE-47 is insignificant when compared with the total aircraft breakrate. If the total aircraft were modeled, the ALE-47 would most likely be in the noise level and not

significantly affect the aircraft's operational suitability at all. Aircraft are constantly down for a variety of reasons and the ALE-47 should not be significant.

The full factorial experiment examined the contribution of the three factors to the average monthly spares level in each theater. In each theater, the results were the same for the factors in terms of magnitude. When tested for significance, however, the results varied across theaters. The greatest contribution to spares level is the amount of spares purchased. The two-level maintenance system seems to settle down to a steady state average with the pipeline full based on all three factors. The more spares that were available in the beginning makes the average higher once steady state is achieved. Reliability of the system is the next most important contributor because it generates the failures. Testability or false removals is only a small portion of the generation of failed units for the pipeline. Since reliability is fairly high, this factor is almost insignificant. The interaction between spares purchased and reliability is a good contributor. The conclusion to be drawn from this is that if spares purchase size is based on system reliability, remember that it is not an equal tradeoff when determining the purchase amount. Another conclusion is that if achieving the warranted reliability appears not to be a problem, the best way to improve the operational suitability of the system would be to purchase

more spares. Spending money improving testability would have far less effect than spending it on spares.

### Recommendations

There are two areas for recommendations in this study. The first set of recommendations are applicable to the ALE-47 System Program Office. They apply to the decision between a two-level and three-level maintenance concept for the system. The second set of recommendations apply to the research itself. These recommend areas for further study using the model developed and areas for improvement in the model itself.

ALE-47 System Program Office. Using the operational requirements and program information available, the research indicates that the system is supportable with a two-level maintenance concept in peacetime. Spares may get very tight if a war surge of the magnitude stated occurs. The best method to improve the operational suitability of the system is to purchase additional spares. Improving reliability will influence the operational suitability but, since the warranty is already in place, it would not be prudent to open the warranty to try to change the reliability. Testability has little effect on operational suitability and should not be viewed as a method to greatly improve the system in the field.

Further Study. The research produced several areas open to further study. A more accurate assessment of the effects of a war is an area for further study. Improvements to the model would have to be made to better characterize the war surge. Items which must be identified would be the number of aircraft moved to the war theater, the number of spares taken with them, the possible acceleration of the repair pipeline, and whether new spares would be built.

Another area for model improvement would be to make the model itself more user friendly. As it stands now, some simulation experience with SLAM II is necessary to modify the input parameters. A user-friendly system would allow the SLAM code to be invisible to the user and allow the user to tailor the model to his specific system. This would be of great value in evaluating System Operational Requirements Documents, a task which system program offices are often required to perform.

Another area for additional study would be to develop a three-level maintenance concept model using the same assumptions and data. This would allow a comparison between the two concepts to determine if any significant differences in operational suitability exist. This would be of great value when making a decision on the support concept to pursue.

Appendix A. Basic Simulation Model SLAM II Network

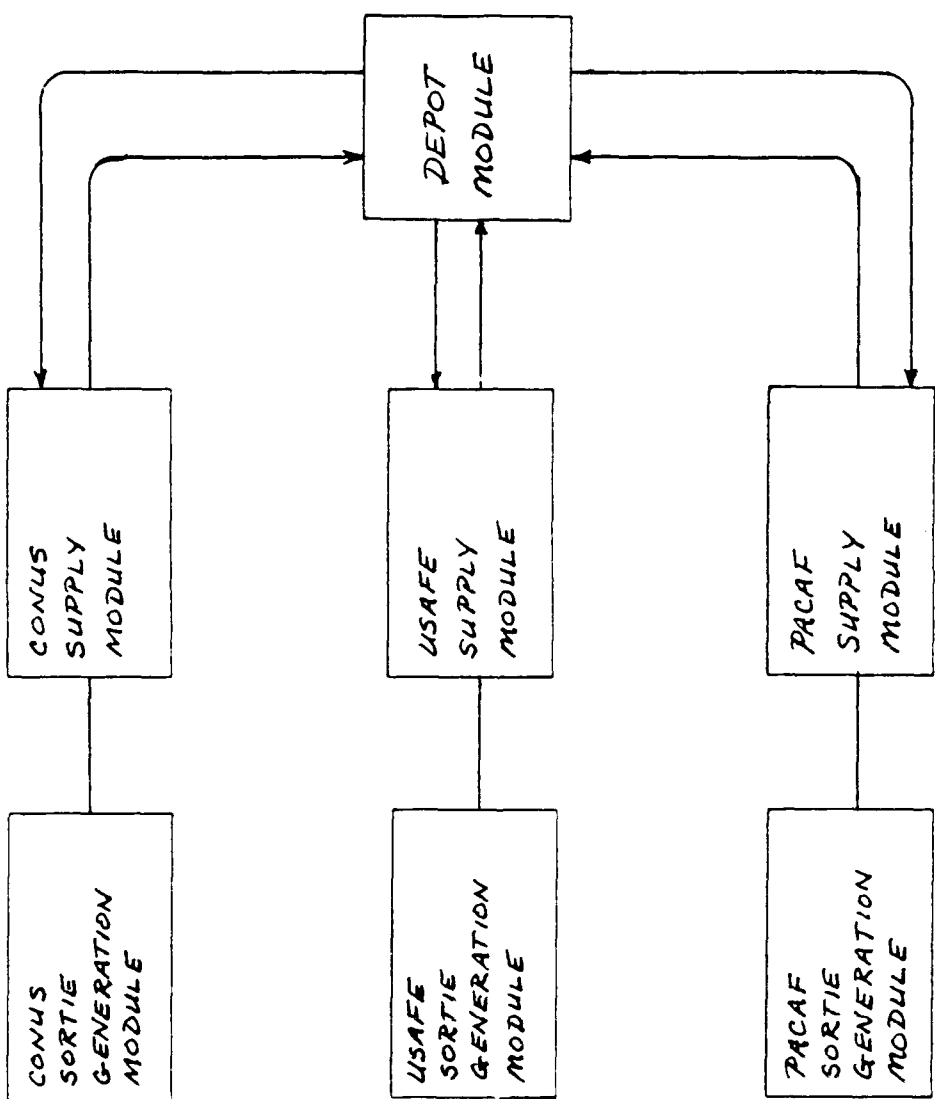

SLAM II Network Flow Diagram

ACA	390	2
ACB	390	5
ACC	156	8
DAY	CLOSE	11 13 15
WEEK	CLOSE	12 14 16

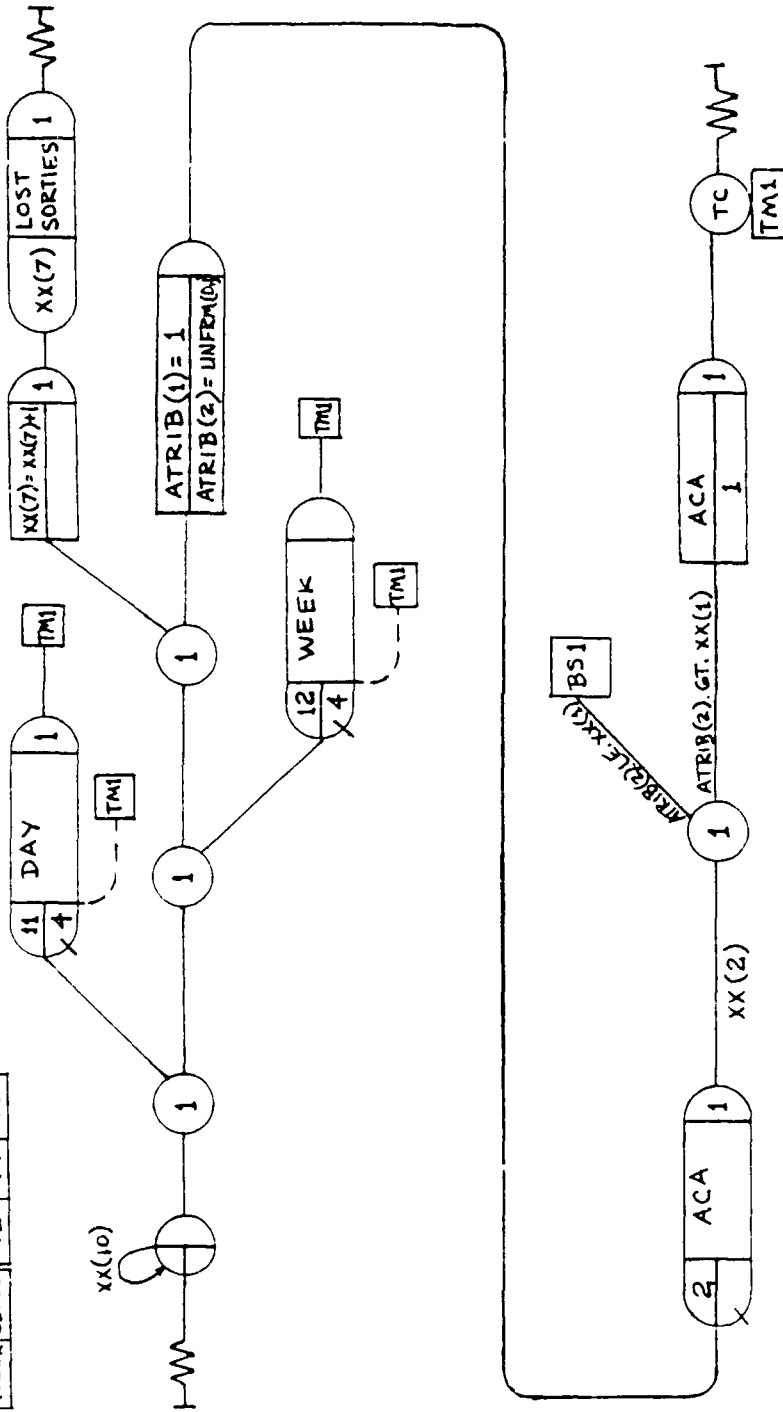

SORTIE GENERATION MODULE

SPLYA	75	1
SPLYB	75	4
SPLYC	35	7
SHIP	CLOSE	3 6 9 10

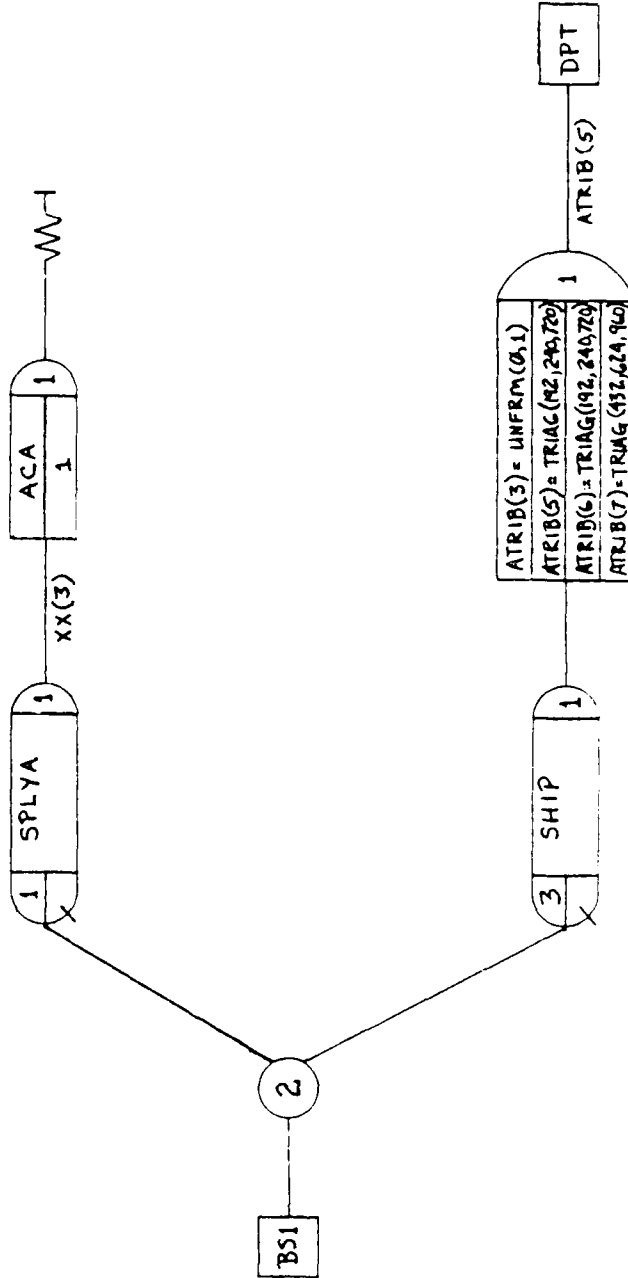

BASE SUPPLY MODULE

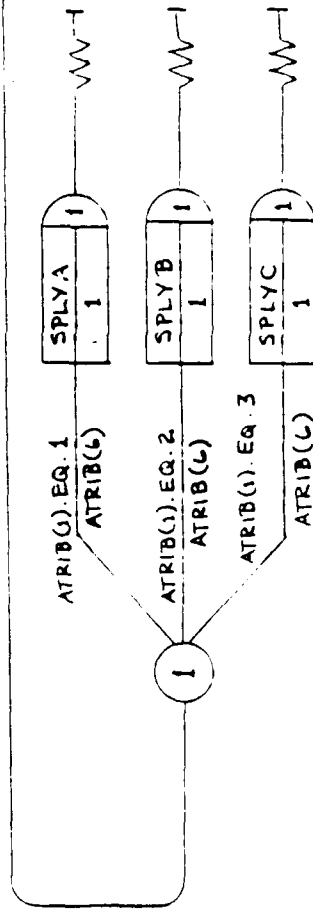
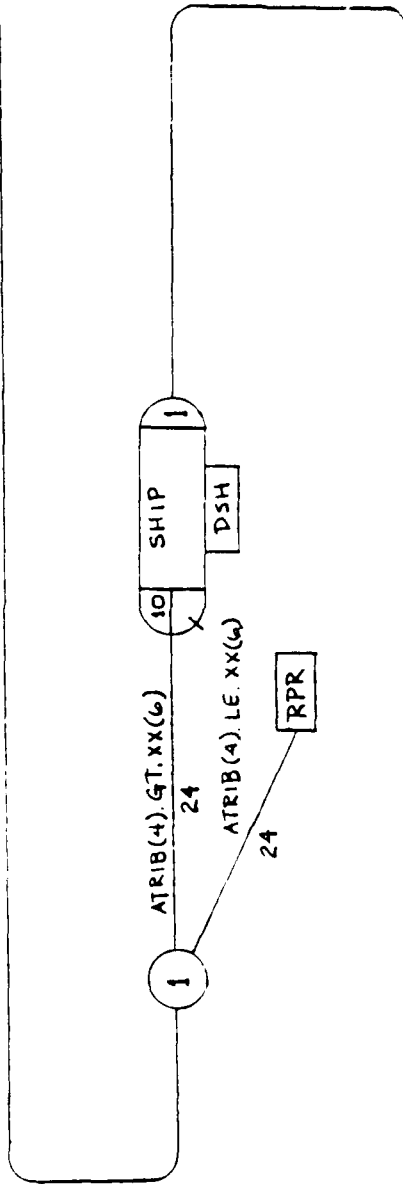
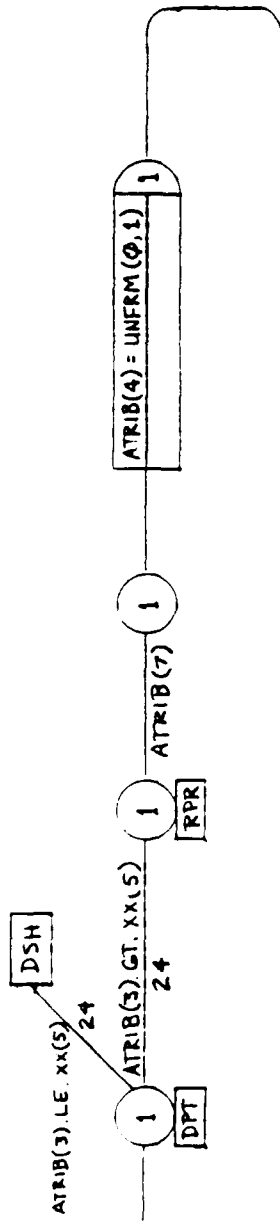

DEPOT MODULE

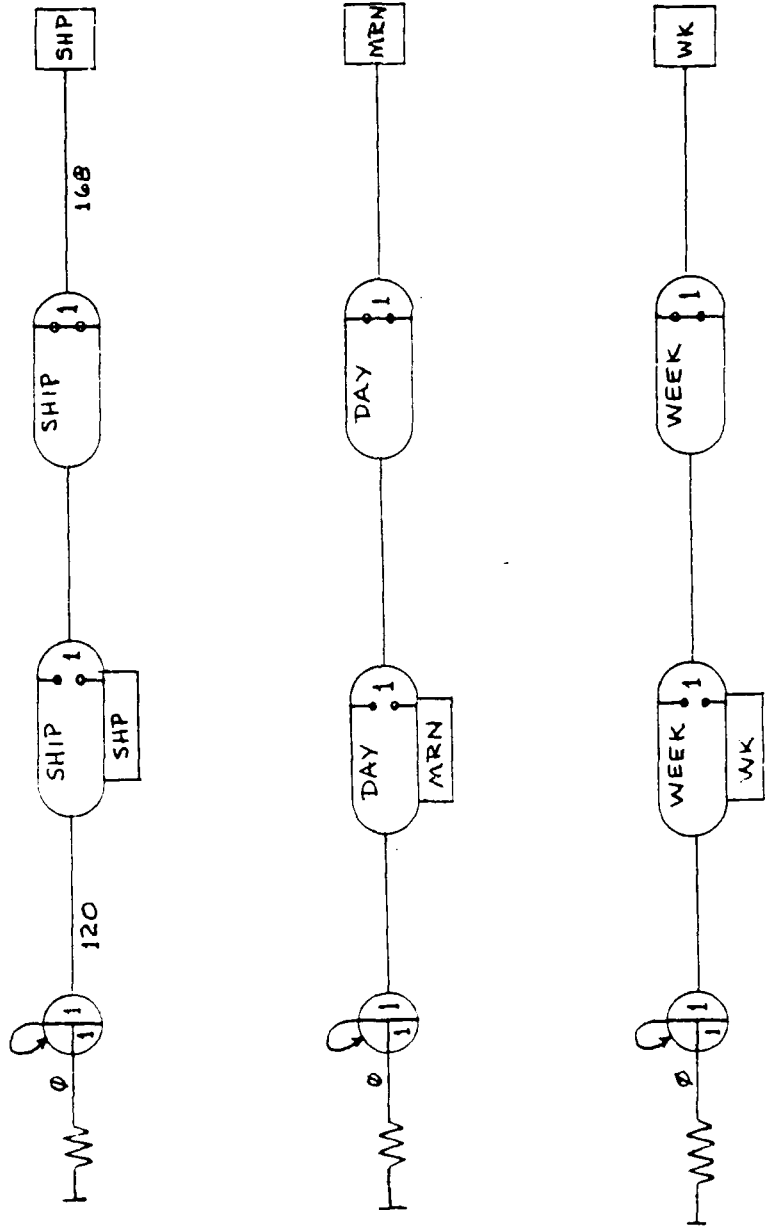

SHIPPING, DAY, AND WEEK MODULES

Appendix B: Basic Simulation Model SLAM II Code

```

GEN,RMOTLEY,HOUR MODEL,7/11/89,30,,,,,72;
LIMITS,16,7,5000;
INTLC,XX(1)=.001475;BREAKRATE+FRR
INTLC,XX(2)=1.5;SORTIE LENGTH
INTLC,XX(3)=1;ON EQUIP M TIME
INTLC,XX(4)=1;OFF EQUIP M TIME
INTLC,XX(5)=.01;FALSE REMOVAL RATE
INTLC,XX(6)=.01;QC FAIL RATE
INTLC,XX(7)=0;A LOST SORTIE COUNTER
INTLC,XX(8)=0;B LOST SORTIE COUNTER
INTLC,XX(9)=0;C LOST SORTIE COUNTER
INTLC,XX(10)=.025641;SGR (CONUS & USAFE)
INTLC,XX(11)=.0641026;SGR (PACAF)
INTLC,XX(12)=12;FLYING DAY LENGTH
INTLC,XX(13)=12;NITE LENGTH
INTLC,XX(14)=120;FLYING WEEK
INTLC,XX(15)=48;DOWN DAYS
;
;       TIME UNIT IS ONE HOUR
;
;   A IS CONUS
;   B IS USAFE
;   C IS PACAF
;
NETWORK;
    RESOURCE/SPLYA(75),1;   A SPARES
    RESOURCE/SPLYB(75),4;   B SPARES
    RESOURCE/SPLYC(35),7;   C SPARES
    RESOURCE/ACA(390),2;    A AIRCRAFT
    RESOURCE/ACB(390),5;    B AIRCRAFT
    RESOURCE/ACC(156),8;    C AIRCRAFT
    GATE/SHIP,CLOSED,3,6,9,10;
    GATE/DAY,CLOSED,11,13,15;
    GATE/WEEK,CLOSED,12,14,16;
;
;1****SORTIE GENERATION MODULE****
;
    CREATE,XX(10);        GENERATE SORTIE RATE
    GOON,1;
    ACT,,NNGAT(DAY).EQ.1,AD1;
    ACT,,NNGAT(DAY).NE.1;
    GOON,1;
    ACT,,NNGAT(WEEK).EQ.1,AW1;
    ACT,,NNGAT(WEEK).NE.1;
    GOON,1;
    ACT,,NNRSC(ACA).LT.1,LSA;
    ACT,,NNRSC(ACA).GE.1;
    ASSIGN,ATRI(1)=1,ATRI(2)=UNFRM(0,1);
    AWAIT(2),ACA;AIRCRAFT AVAILABLE?

```

```

ACT/1,XX(2);SORTIE
GOON,1;
ACT/2,,ATRIB(2).LE.XX(1),BS1;BREAK A
ACT/3,,ATRIB(2).GT.XX(1);NO BREAK A
FREE,ACA;RELEASE AC FOR ANOTHER MISSION
TM1 TERM;
;
AD1 AWAIT(11/4),DAY,BALK(TM1),1;
ACT,,TM1;
AW1 AWAIT(12/4),WEEK,BALK(TM1),1;
ACT,,TM1;
LSA ASSIGN,XX(7)=XX(7)+1.0;
COLCT,XX(7),LOST SORTIES A;
TERM;
;
;*****BASE SUPPLY MODULE*****
;
BS1 GOON,2;
ACT,0,,RR1;
ACT,0,,BH1;
RR1 AWAIT(1),SPLYA;WAIT FOR LRU
ACT/4,XX(3);R&R PART
FREE,ACA;
TERM;
BH1 AWAIT(3),SHIP;
ASSIGN,ATRIB(3)=UNFRM(0,1);
ASSIGN,ATRIB(5)=TRIAG(192,240,720);
ASSIGN,ATRIB(6)=TRIAG(192,240,720);
ASSIGN,ATRIB(7)=TRIAG(432,624,960);
ACT/5,ATRIB(5),,DPT;SHIP A TO DEPOT
;
;2*****SORTIE GENERATION MODULE*****
;
CREATE,XX(10); GENERATE SORTIE RATE
GOON,1;
ACT,,NNGAT(DAY).EQ.1,AD2;
ACT,,NNGAT(DAY).NE.1;
GOON,1;
ACT,,NNGAT(WEEK).EQ.1,AW2;
ACT,,NNGAT(WEEK).NE.1;
GOON,1;
ACT,,NNRSC(ACB).LT.1,LSB;
ACT,,NNRSC(ACB).GE.1;
ASSIGN,ATRIB(1)=2,ATRIB(2)=UNFRM(0,1);
AWAIT(5),ACB;AIRCRAFT AVAILABLE?
ACT/6,XX(2);SORTIE
GOON,1;
ACT/7,,ATRIB(2).LE.XX(1),BS2;BREAK B
ACT/8,,ATRIB(2).GT.XX(1);NO BREAK B
FREE,ACB;RELEASE AC FOR ANOTHER MISSION
TM2 TERM;
;

```

```

AD2  AWAIT(13/4),DAY,BALK(TM2),1;
      ACT,,,TM2;
AW2  AWAIT(14/4),WEEK,BALK(TM2),1;
      ACT,,,TM2;
LSB  ASSIGN,XX(8)=XX(8)+1.0;
      COLCT,XX(8),LOST SORTIES B;
      TERM;
;
;*****BASE SUPPLY MODULE*****
;
BS2  GOON,2;
      ACT,0,,RR2;
      ACT,0,,BH2;
RR2  AWAIT(4),SPLYB;WAIT FOR LRU
      ACT/9,XX(3);R&R PART
      FREE,ACB;
      TERM;
BH2  AWAIT(6),SHIP;
      ASSIGN,TRIB(3)=UNFRM(0,1);
      ASSIGN,TRIB(5)=TRIAG(192,288,720);
      ASSIGN,TRIB(6)=TRIAG(192,288,720);
      ASSIGN,TRIB(7)=TRIAG(432,624,960);
      ACT/10,TRIB(5),,DPT;SHIP B TO DEPOT
;
;3*****SORTIE GENERATION MODULE*****
;
      CREATE,XX(11);      GENERATE SORTIE RATE
      GOON,1;
      ACT,,NNGAT(DAY).EQ.1,AD3;
      ACT,,NNGAT(DAY).NE.1;
      GOON,1;
      ACT,,NNGAT(WEEK).EQ.1,AW3;
      ACT,,NNGAT(WEEK).NE.1;
      GOON,1;
      ACT,,NNRSC(ACC).LT.1,LSC;
      ACT,,NNRSC(ACC).GE.1;
      ASSIGN,TRIB(1)=3,TRIB(2)=UNFRM(0,1);
      AWAIT(8),ACC;AIRCRAFT AVAILABLE?
      ACT/11,XX(2);SORTIE
      GOON,1;
      ACT/12,,TRIB(2).LE.XX(1),BS3;BREAK C
      ACT/13,,TRIB(2).GT.XX(1);NO BREAK C
      FREE,ACC;RELEASE AC FOR ANOTHER MISSION
TM3  TERM;
;
AD3  AWAIT(15/4),DAY,BALK(TM3),1;
      ACT,,,TM3;
AW3  AWAIT(16/4),WEEK,BALK(TM3),1;
      ACT,,,TM3;
LSC  ASSIGN,XX(9)=XX(9)+1.0;
      COLCT,XX(9),LOST SORTIES C;
      TERM;

```

```

;
;*****BASE SUPPLY MODULE*****
;
BS3   GOON,2;
      ACT,0,,RR3;
      ACT,0,,BH3;
RR3   AWAIT(7),SPLYC;WAIT FOR LRU
      ACT/14,XX(3);R&R PART C
      FREE,ACC;
      TERM;
BH3   AWAIT(9),SHIP;
      ASSIGN,TRIB(3)=UNFRM(0,1);
      ASSIGN,TRIB(5)=TRIAG(192,384,720);
      ASSIGN,TRIB(6)=TRIAG(192,384,720);
      ASSIGN,TRIB(7)=TRIAG(432,624,960);
      ACT/15,TRIB(5),,DPT;SHIP C TO DEPOT
;
;*****DEPOT MODULE*****
;
DPT   GOON,1;
      ACT/16,24,TRIB(3).LE.XX(5),DSH;PART OK
      ACT/17,24,TRIB(3).GT.XX(5);PART FAILED
RPR   GOON;
      ACT/18,TRIB(7);DEPOT REPAIR
      GOON;
      ASSIGN,TRIB(4)=UNFRM(0,1);
      GOON,1;
      ACT/19,24,TRIB(4).LE.XX(6),RPR;FAIL QC CHECK
      ACT/20,24,TRIB(4).GT.XX(6);PASS QC CHECK
DSH   AWAIT(10),SHIP;AWAIT SHIPPING
      GOON,1;
      ACT/21,TRIB(6),TRIB(1).EQ.1,S1;SHIP TIME A
      ACT/22,TRIB(6),TRIB(1).EQ.2,S2;SHIP TIME B
      ACT/23,TRIB(6),TRIB(1).EQ.3,S3;SHIP TIME C
S1    FREE,SPLYA;
      TERM;
S2    FREE,SPLYB;
      TERM;
S3    FREE,SPLYC;
      TERM;
;
;*****SHIPPING MODULE*****
;
      CREATE,,,1,1;
      ACT,120;
SHP   OPEN,SHIP;
      ACT;
      CLOSE,SHIP;
      ACT,168,,SHP;

```

```

;
;*****FLYING DAY MODULE*****
;
      CREATE,,,,1,1;
MRN   OPEN, DAY;
      ACT, XX(12);
      CLOSE, DAY;
      ACT, XX(13), ,MRN;
;
;*****FLYING WEEK*****
;
      CREATE,,,,1,1;
WK    OPEN, WEEK;
      ACT, XX(14);
      CLOSE, WEEK;
      ACT, XX(15), ,WK;
;
      ENDNETWORK;
RECORD, TNOW, TIME, ,T, 24, 8760, 9480;
VAR, NNRSC(SPLYA), A, CONUS, 0, 80;
VAR, NNRSC(SPLYB), B, USAFE, 0, 80;
VAR, NNRSC(SPLYC), C, PACAF, 0, 80;
INIT, 0, 9480; 8760 HRS TRANSIENT
FIN;

```

Appendix C: Means from Basic Simulation Model

CONUS	USAFE	PACAF
39.54839	45.3871	20.12903
44.03226	45.6129	25.29032
43.3871	31.41935	25.29032
31.58065	50.45161	16.58065
39.6129	43.48387	24.51613
40.70968	38.25806	22.67742
47.64516	46.80645	17.16129
52.16129	41.80645	25.51613
38.93548	42.67742	21.45161
50.48387	48.41935	22.12903
37.51613	41.25806	21.6129
37.51613	33.51613	19.90323
37.29032	49.87097	23
40.80645	40.96774	23.22581
38.67742	44.87097	22.22581
44.96774	48.6129	17.16129
40.12903	45.16129	20
47.03226	38.87097	15.67742
37.93548	44.29032	18.51613
50.25806	44.16129	20.77419
45.58065	37.6129	22.96774
46.45161	45.41935	14.3871
32.70968	43.54839	20.96774
39.80645	39.3871	14.87097
45.09677	32.70968	25.25806
41.6129	44.06452	20.80645
44.96774	33.3871	19.29032
34.51613	45.54839	18
34.3871	48	21.80645
35.70968	41.25806	22.45161

Appendix D: Wilk-Shapiro/Rankit Plots for Theater Means and Minimums

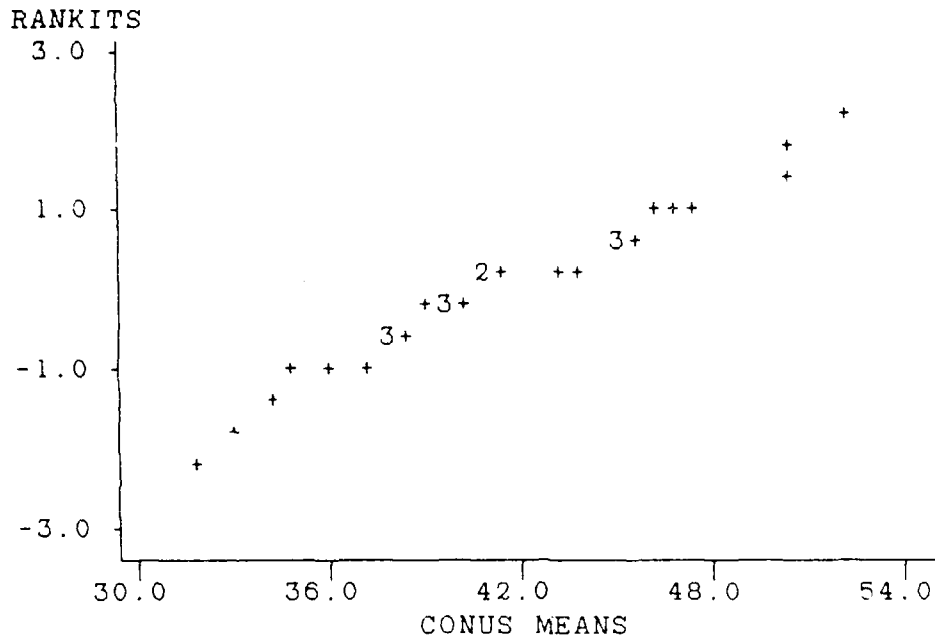

APPROX. WILK-SHAPIRO 0.9844 30 CASES PLOTTED

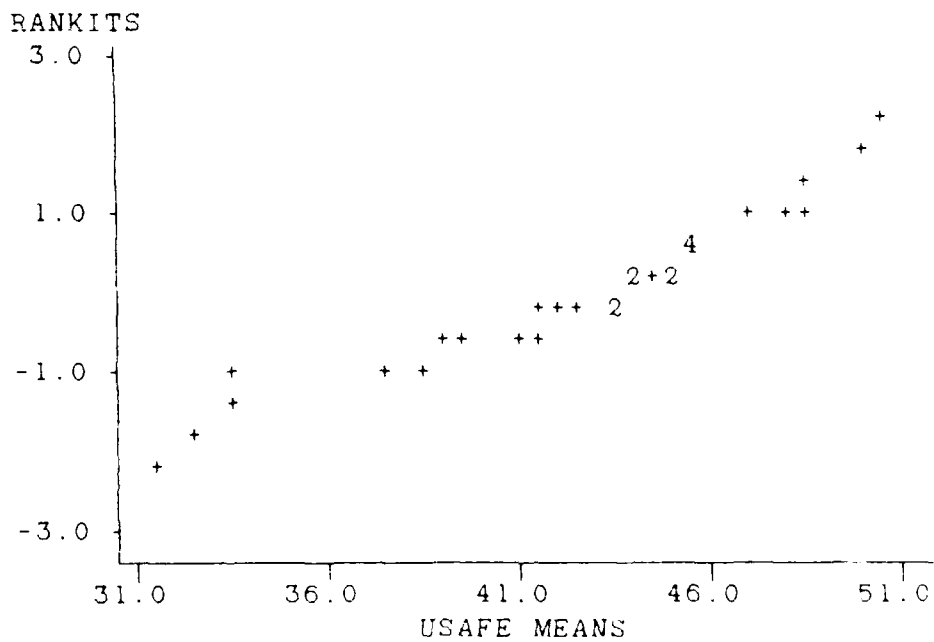

APPROX. WILK-SHAPIRO 0.9464 30 CASES PLOTTED

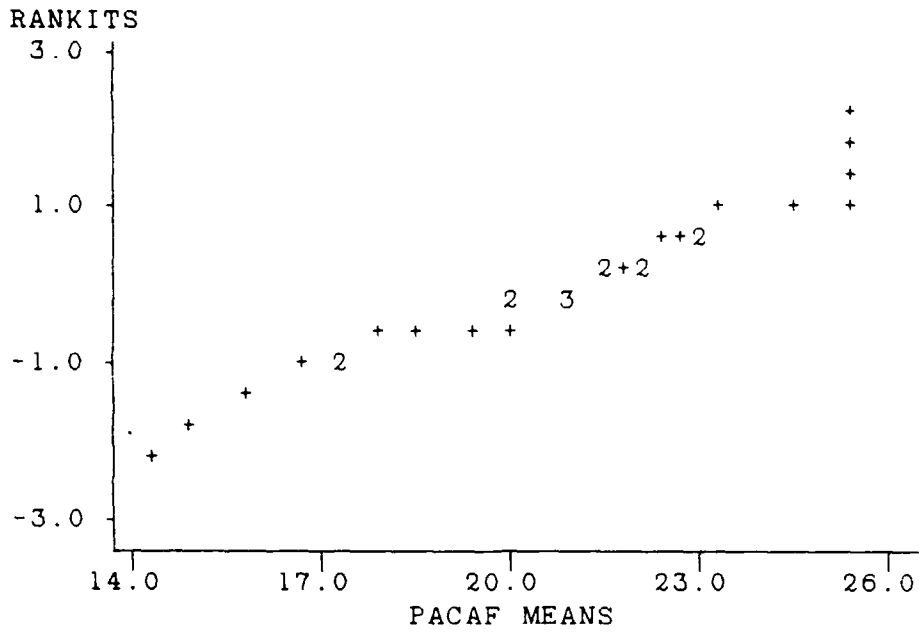

APPROX. WILK-SHAPIRO 0.9684 30 CASES PLOTTED

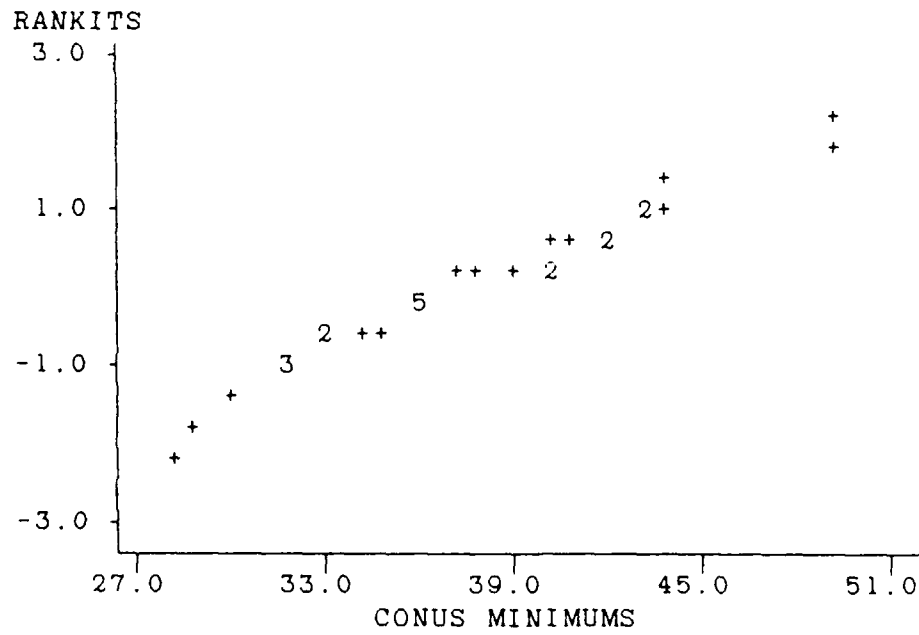

APPROX. WILK-SHAPIRO 0.9787 30 CASES PLOTTED

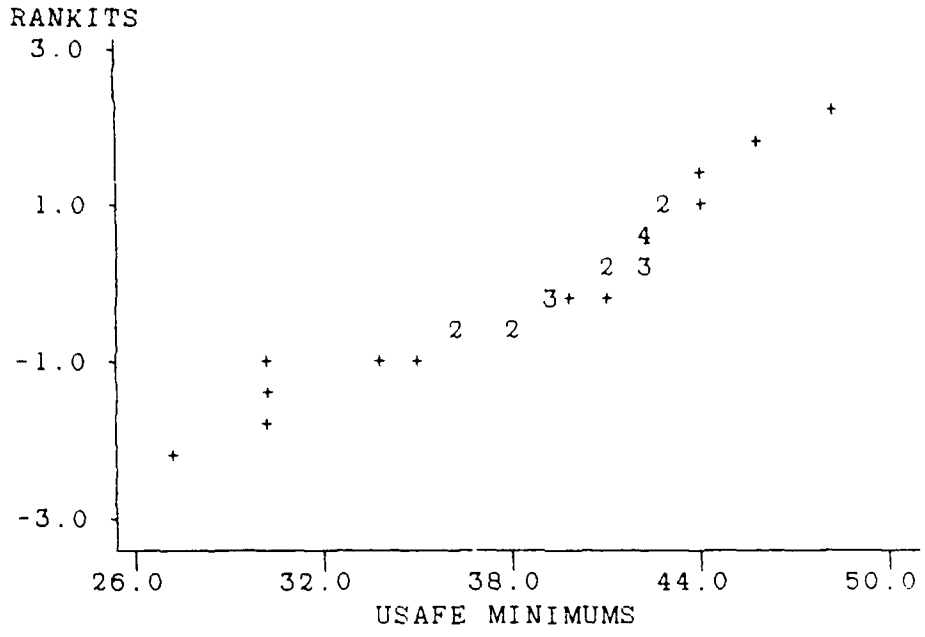

APPROX. WILK-SHAPIRO 0.9183 30 CASES PLOTTED

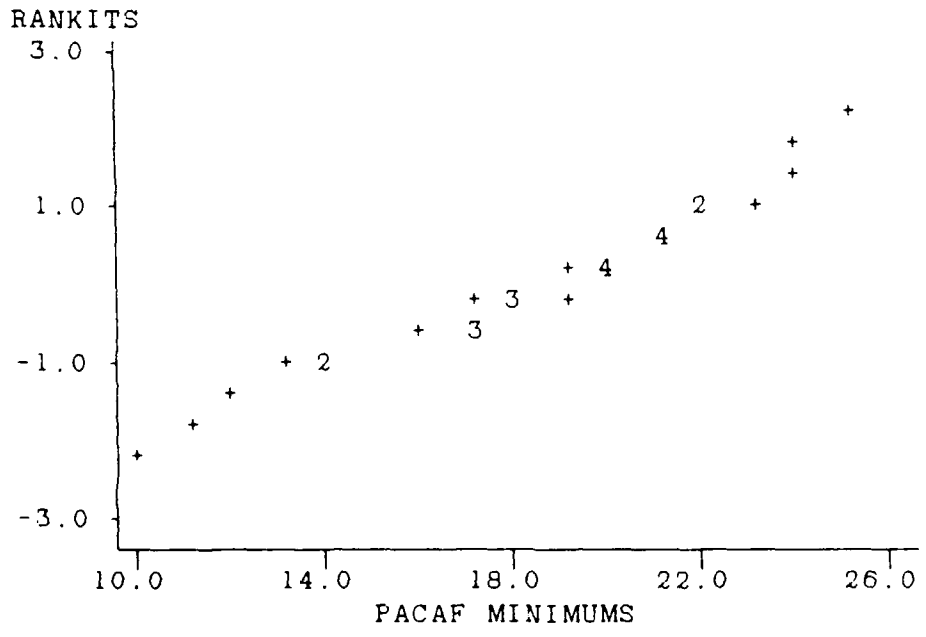

APPROX. WILK SHAPIRO 0.9685 30 CASES PLOTTED

Appendix E: Theater Histograms for Count  
of Daily Spares Levels

NUMBER OF DAYS AT SPARES LEVEL.  
FOR CONUS AIRCRAFT (9 YEARS OF DATA)

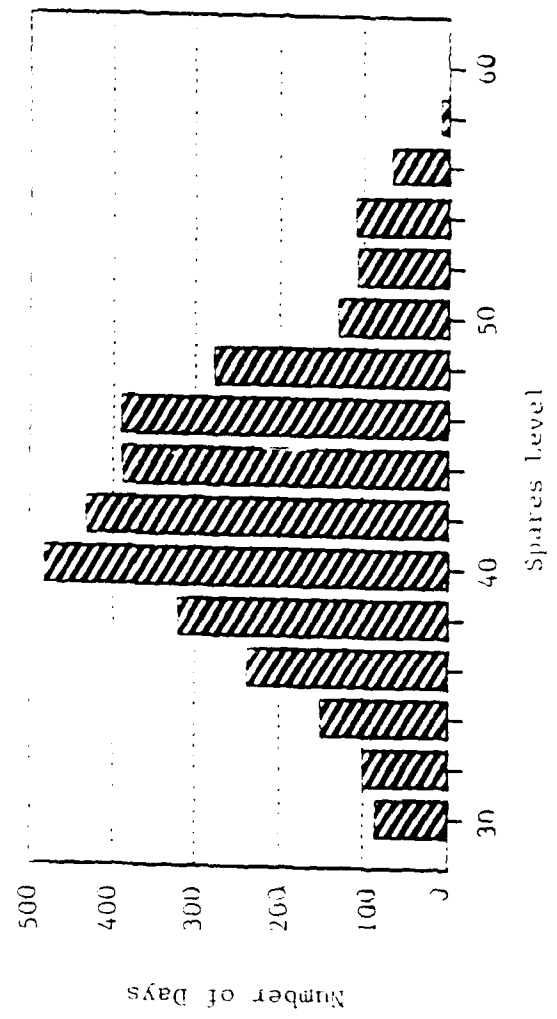

**NUMBER OF DAYS AT SPARES LEVEL  
FOR USAFE AIRCRAFT (9 YEARS OF DATA)**

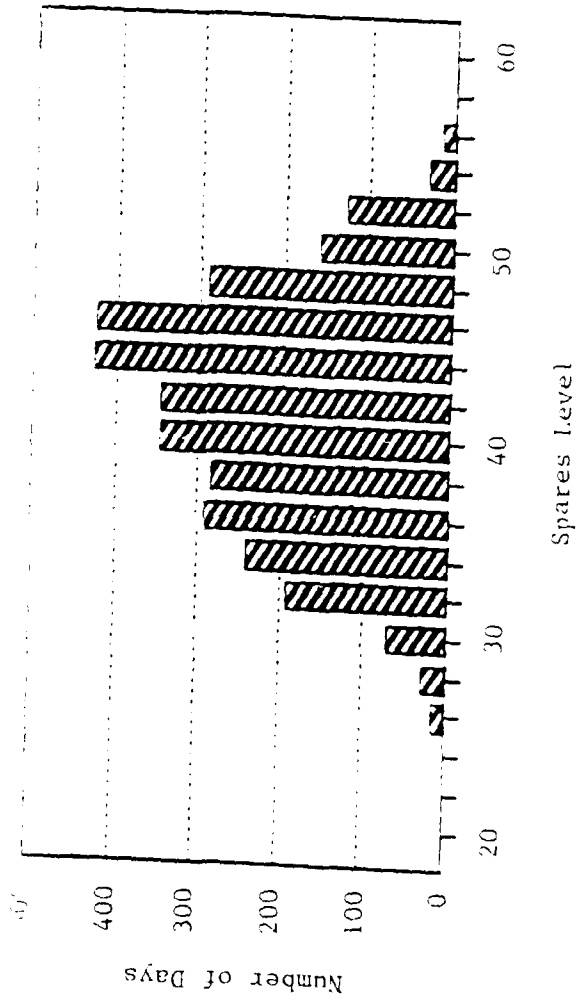

# NUMBER OF DAYS AT SPARES LEVEL FOR PACAF AIRCRAFT (9 YEARS OF DATA)

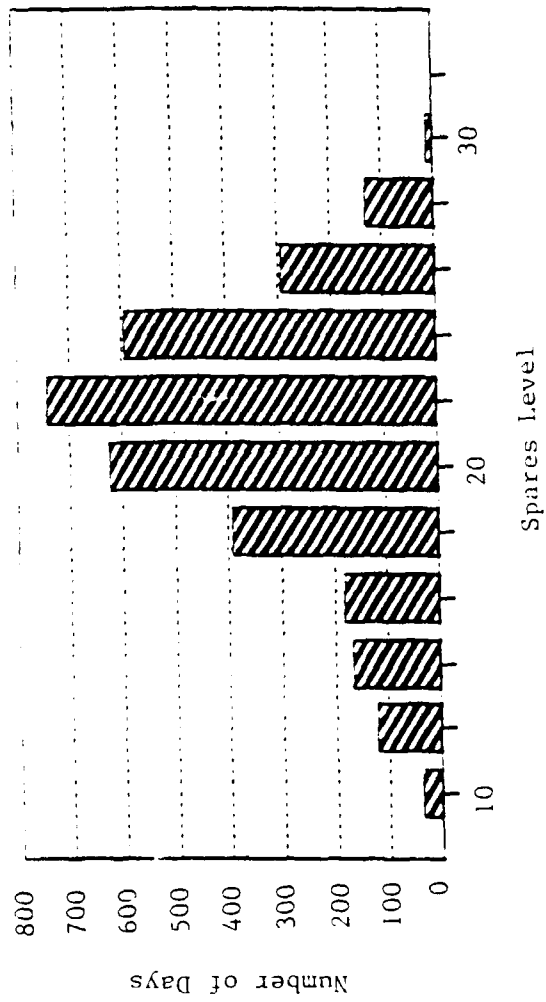

Appendix F: Paired t Test Results for Shipping Time  
Sensitivity Analysis

PAIRED T TEST FOR CONUS(7) - CONUS(2)  
MEAN -3.438 STD ERROR 8.918E-01  
T -3.85  
DF 29  
P 0.0006  
CASES INCLUDED 30 MISSING CASES 0

PAIRED T TEST FOR USAFE(7) - USAFE(2)  
MEAN -1.116 STD ERROR 0.996  
T -1.12  
DF 29  
P 0.2716  
CASES INCLUDED 30 MISSING CASES 0

PAIRED T TEST FOR PACAF(7) - PACAF(2)  
MEAN -6.183E-01 STD ERROR 9.098E-01  
T -0.68  
DF 29  
P 0.5021  
CASES INCLUDED 30 MISSING CASES 0

PAIRED T TEST FOR CONUS(7) - CONUS(14)  
MEAN 2.722 STD ERROR 1.092  
T 2.49  
DF 29  
P 0.0187  
CASES INCLUDED 30 MISSING CASES 0

PAIRED T TEST FOR USAFE(7) - USAFE(14)  
MEAN 4.827 STD ERROR 1.107  
T 4.36  
DF 29  
P 0.0001  
CASES INCLUDED 30 MISSING CASES 0

PAIRED T TEST FOR PACAF(7) - PACAF(14)  
MEAN 2.211 STD ERROR 7.346E-01  
T 3.01  
DF 29  
P 0.0054  
CASES INCLUDED 30 MISSING CASES 0

Appendix G: Factorial Design Multiple Regression Output by Theater

UNWEIGHTED LEAST SQUARES LINEAR REGRESSION FOR CONUS

PREDICTOR VARIABLES	COEFFICIENT	STD ERROR	STUDENT'S T	P
CONSTANT	39.080	3.6989E-01	105.65	0.0000
R	17.577	3.6989E-01	47.52	0.0000
T	9.4341E-01	3.6989E-01	2.55	0.0110
SP	29.362	3.6989E-01	79.38	0.0000
RT	-1.3488	3.6989E-01	-3.65	0.0004
RSP	7.8585	3.6989E-01	21.25	0.0000
TSP	1.0063	3.6989E-01	2.72	0.0069
RTSP	-1.2859	3.6989E-01	-3.48	0.0007

CASES INCLUDED 240 MISSING CASES 0  
 DEGREES OF FREEDOM 232  
 OVERALL F 1.293E+03 P VALUE 0.0000  
 ADJUSTED R SQUARED 0.9743  
 R SQUARED 0.9750  
 RESID. MEAN SQUARE 32.84

UNWEIGHTED LEAST SQUARES LINEAR REGRESSION FOR USAFE

PREDICTOR VARIABLES	COEFFICIENT	STD ERROR	STUDENT'S T	P
CONSTANT	39.122	3.3652E-01	116.26	0.0000
R	18.149	3.3652E-01	53.93	0.0000
T	1.3540	3.3652E-01	4.02	0.0001
SP	29.063	3.3652E-01	86.37	0.0000
RT	-0.9573	3.3652E-01	-2.84	0.0049
RSP	8.0898	3.3652E-01	24.04	0.0000
TSP	0.9823	3.3652E-01	2.92	0.0040
RTSP	-1.3290	3.3652E-01	-3.95	0.0002

CASES INCLUDED 240 MISSING CASES 0  
 DEGREES OF FREEDOM 232  
 OVERALL F 1.571E+03 P VALUE 0.0000  
 ADJUSTED R SQUARED 0.9787  
 R SQUARED 0.9793  
 RESID. MEAN SQUARE 27.18

UNWEIGHTED LEAST SQUARES LINEAR REGRESSION OF P

PREDICTOR VARIABLES	COEFFICIENT	STD ERROR	STUDENT'S T	P
CONSTANT	20.689	2.0899E-01	99.00	0.0000
R	8.1952	2.0899E-01	39.21	0.0000
T	-2.4032E-01	2.0899E-01	-1.15	0.2500
SP	15.179	2.0899E-01	72.63	0.0000
RT	-3.0430E-01	2.0899E-01	-1.46	0.1426
RSP	2.7266	2.0899E-01	13.05	0.0000
TSP	-1.4247E-02	2.0899E-01	-0.07	0.9025
RTSP	-7.9839E-02	2.0899E-01	-0.38	0.7033

CASES INCLUDED	240	MISSING CASES	0
DEGREES OF FREEDOM	232		
OVERALL F	998.2	P VALUE	0.0000
ADJUSTED R SQUARED	0.9669		
R SQUARED	0.9679		
RESID. MEAN SQUARE	10.48		

## BIBLIOGRAPHY

1. Aeronautical Systems Division, Air Force Systems Command. AN/ALE-47 Countermeasures Dispenser System Specification. 8 June 1988.
2. Aeronautical Systems Division, Air Force Systems Command. Use Study for AN/ALE-47 Countermeasures Dispenser System (CMDS). December 1988.
3. "Decentralized Maintenance Boosts Sortie Rates, Hours [TAC]," Aviation Week and Space Technology, 120: 64-65+ (March 19, 1984).
4. "Navy Official Cites Need for IR Jammer, Missile Detector on Tactical Aircraft," Aviation Week and Space Technology, 129:61 (September 19, 1988).
5. "Tracor Plans to Expand Efforts on Expendables, Decoy Systems," Aviation Week and Space Technology, 129:105 (September 26, 1988).
6. Boyle, Edward and others. "The Aircraft Maintenance Workforce Now and in the Twenty-First Century," Air Force Journal of Logistics, 9: 3-5 (Fall 1985).
7. Bramlett, T. P. AN/ALE-40 Item Manager. Telephone Interview. Warner-Robins Air Logistics Center, 2 July 1989.
8. \_\_\_\_\_. Telephone Interview, Warner-Robins Air Logistics Center, 5 July 1989.
9. David, H. A. Order Statistics. New York: John Wiley & Sons, Incorporated, 1970.
10. Department of the Air Force. Action Officers Guide for Reliability and Maintainability. HQ TAC, 1 October 1986.
11. Department of the Air Force. Air force systems Command Annual Reliability and Maintainability Plan. HQ AFSC, November 1985.
12. General Dynamics. F-16 AIS Support System Alternatives Study, Second Interim Briefing. 15 March 1989.

13. Gill, Leroy. Class Notes from AMGT 559, Life Cycle Cost and Reliability. School of Systems and Logistics, Air Force Institute of Technology (AU), Wright-Patterson AFB OH, Spring 1989.
14. Hicks, Charles R. Fundamental Concepts in the Design of Experiments. New York: Holt, Rinehart and Winston, Incorporated, 1973.
15. Hillestad, R. J. Dyna-METRIC: Dynamic Multi-Echelon Technique for Recoverable Item Control. Contract F49620-82-C-0018. Santa Monica CA: The RAND Corporation, July 1982.
16. Isaacson, Karen E. and others. Dyna-METRIC Version 4: Modeling Worldwide Logistics Support of Aircraft Components. Contract F49620-86-C-0008. Santa Monica CA: The RAND Corporation, May 1988.
17. Kleijnen, Jack P. C. Statistical Techniques in Simulation, Parts I and II. New York: Marcel Dekker, Inc., 1974.
18. Law, Averill M. and W. David Kelton. Simulation Modeling and Analysis. New York: McGraw-Hill Book Company, 1982.
19. Ott, Lyman. An Introduction to Statistical Methods and Data Analysis. Boston: PWS-KENT Publishing Company, 1988.
20. Pidd, Michael. Computer Simulation in Management Science. New York: John Wiley & Sons, 1986.
21. Pritsker, A. Alan B. Introduction to Simulation and SLAM II. West Lafayette IN: Systems Publishing Corporation, 1986.
22. Robinson, Lt Col James. Class Notes from OPER 525, Analysis of Logistics Systems. School of Engineering, Air Force Institute of Technology (AU), Wright-Patterson AFB OH, Fall 1988.
23. Sargent, Robert G. "An Overview of Verification and Validation of Simulation Models," Proceedings of the 1987 Winter Simulation Conference. 33-39.
24. STATISTIX II, An Interactive Statistical Analysis Program for Microcomputers. Roseville MN: NH Analytical Software.

25. Welch, Peter D. The Statistical Analysis of Simulation Results. Academic Press, Incorporated, 1983.
26. Winston, Wayne L. Operations Research: Applications and Algorithms. Boston: PWS Publishers, 1987.

Vita

Captain Rodney C. Motley [REDACTED]

[REDACTED]

[REDACTED] He entered North Carolina State University in Raleigh, North Carolina in August 1978 from which he received the degree of Bachelor of Science in Materials Engineering in December 1982 and was commissioned as a Second Lieutenant in the Air Force through ROTC. He was assigned to Aeronautical Systems Division, Wright-Paterson AFB as a Reliability Engineer in the Directorate for Reconnaissance/Strike and Electronic Warfare in January 1983. In November of 1987, he was assigned as the Lead Integration Engineer for the EF-111A and F-4G Wild Weasel Upgrade Programs. In May 1988, he entered the School of Systems and Logistics, Air Force Institute of Technology, to pursue a Master of Science degree in Systems Management. Upon graduation, he was assigned to Space Systems Division, Los Angeles AFB. He is a member of Sigma Iota Epsilon, the national management honor society.

[REDACTED]

[REDACTED]

[REDACTED]

REPORT DOCUMENTATION PAGE

1a. REPORT SECURITY CLASSIFICATION UNCLASSIFIED		1b. RESTRICTIVE MARKINGS	
2a. SECURITY CLASSIFICATION AUTHORITY		3. DISTRIBUTION/AVAILABILITY OF REPORT Approved for public release; distribution unlimited	
2b. DECLASSIFICATION/DOWNGRADING SCHEDULE			
4. PERFORMING ORGANIZATION REPORT NUMBER(S) AFIT/GSM/ENS/89S-30		5. MONITORING ORGANIZATION REPORT NUMBER(S)	
6a. NAME OF PERFORMING ORGANIZATION School of Systems and Logistics	6b. OFFICE SYMBOL (if applicable) AFIT/LSY	7a. NAME OF MONITORING ORGANIZATION	
6c. ADDRESS (City, State, and ZIP Code) Air Force Institute of Technology Wright-Patterson AFB OH 45433-6583		7b. ADDRESS (City, State, and ZIP Code)	
8a. NAME OF FUNDING/SPONSORING ORGANIZATION AN/ALE-47 CMDS System Program Office	8b. OFFICE SYMBOL (if applicable) ASD/RWWQ	9. PROCUREMENT INSTRUMENT IDENTIFICATION NUMBER	
8c. ADDRESS (City, State, and ZIP Code) Deputy for Reconnaissance & Electronic Warfare Systems Wright-Patterson AFB OH 45433-6503		10. SOURCE OF FUNDING NUMBERS	
		PROGRAM ELEMENT NO.	PROJECT NO.
		TASK NO.	WORK UNIT ACCESSION NO.
11. TITLE (Include Security Classification) AN OPERATIONAL SUITABILITY EVALUATION TECHNIQUE FOR AVIONICS SUPPORTED WITH TWO-LEVEL MAINTENANCE			
12. PERSONAL AUTHOR(S) Rodney C. Motley, B.S., Captain, USAF			
13a. TYPE OF REPORT MS Thesis	13b. TIME COVERED FROM _____ TO _____	14. DATE OF REPORT (Year, Month, Day) 1989 September	15. PAGE COUNT 109
16. SUPPLEMENTARY NOTATION			
17. COSATI CODES		18. SUBJECT TERMS (Continue on reverse if necessary and identify by block number) Reliability, Maintainability Maintenance, Logistic Support	
FIELD	GROUP		
13	08		
15	05		
19. ABSTRACT (Continue on reverse if necessary and identify by block number)  Thesis Advisor: James N. Robinson, LT COL, USAF Assistant Professor Department of Operations Research  Approved for public release: IAW AFR 190-1. <i>Larry W. Emmelhainz</i> LARRY W. EMMELHAINZ, Lt Col, USAF 14 Oct 89 Director of Research and Consultation Air Force Institute of Technology (AU) Wright-Patterson AFB OH 45433-6583			
20. DISTRIBUTION/AVAILABILITY OF ABSTRACT <input checked="" type="checkbox"/> UNCLASSIFIED/UNLIMITED <input type="checkbox"/> SAME AS RPT. <input type="checkbox"/> DTIC USERS		21. ABSTRACT SECURITY CLASSIFICATION UNCLASSIFIED	
22a. NAME OF RESPONSIBLE INDIVIDUAL James N. Robinson		22b. TELEPHONE (Include Area Code) (513) 255-3362	22c. OFFICE SYMBOL AFIT/ENS

UNCLASSIFIED

The purpose of this study was to develop a technique for evaluating operational suitability of new avionics systems with a two-level maintenance support system. The technique was primarily needed early in the design phases of development programs. The focus would be on could a system meet its operational requirements as set down in program documentation such as the Systems Operational Requirements Document (SORD) with a two-level maintenance concept.

The study had two objectives: develop the technique and demonstrate it on a real system. The AN/ALE-47 Countermeasures Dispenser System was used to demonstrate the technique. A SLAM II simulation model was developed which used operational requirements and three system factors as input parameters. The system factors were reliability, testability, and the initial spares purchase.

Probability distributions were developed for the mean and minimum monthly theater spares level. The average drop in monthly spares level due to the stated war surge was determined. The probability of having enough spares to handle the war surge drop was determined. This allowed quantification of the operational suitability of the system with the two-level concept.

An additional analysis determined the general effects of each of the system factors on the monthly theater spares level through the use of a  $2^k$  Factorial Design. This information aids the user in determining which factors should receive attention to improve the operational suitability of the system with a two-level maintenance concept.

UNCLASSIFIED