

AD-A216 599

Determining the Effects of Microwave Power and C-field Setting on the Frequency of a Cesium Atomic Frequency Standard

S. K. KARUZA, W. A. JOHNSON, and F. J. VOIT
Electronics Research Laboratory
The Aerospace Corporation
El Segundo, CA 90245

31 December 1989

Prepared for

SPACE SYSTEMS DIVISION
AIR FORCE SYSTEMS COMMAND
Los Angeles Air Force Base
P.O. Box 92960
Los Angeles, CA 90009-2960

APPROVED FOR PUBLIC RELEASE;
DISTRIBUTION UNLIMITED

DTIC
ELECTE
JAN 11 1990
S B D

90 01 10 136

This report was submitted by The Aerospace Corporation, El Segundo, CA 90245, under Contract No. F04701-88-C-0089 with the Space Systems Division, P.O. Box 92960, Los Angeles, CA 90009-2960. It was reviewed and approved for The Aerospace Corporation by M. J. Daugherty, Director, Electronics Research Laboratory. Capt M. J. Mitchell, USAF, was the project officer.

This report has been reviewed by the Public Affairs Office (PAS) and is releasable to the National Technical Information Service (NTIS). At NTIS, it will be available to the general public, including foreign nationals.

This technical report has been reviewed and is approved for publication. Publication of this report does not constitute Air Force approval of the report's findings or conclusions. It is published only for the exchange and stimulation of ideas.

Michael J Mitchell

M. J. MITCHELL, CAPT, USAF
MOIE Project Officer
SSD/CWNZS

Raymond M Leong

RAYMOND M. LEONG, MAJ, USAF
MOIE Program Manager
AFSTC/WCO OL-AB

REPORT DOCUMENTATION PAGE

1a. REPORT SECURITY CLASSIFICATION Unclassified			1b. RESTRICTIVE MARKINGS		
2a. SECURITY CLASSIFICATION AUTHORITY			3. DISTRIBUTION/AVAILABILITY OF REPORT Approved for public release; distribution unlimited.		
2b. DECLASSIFICATION/DOWNGRADING SCHEDULE			4. PERFORMING ORGANIZATION REPORT NUMBER(S) TR-0089(4470-03)-1		
4. PERFORMING ORGANIZATION REPORT NUMBER(S) TR-0089(4470-03)-1			5. MONITORING ORGANIZATION REPORT NUMBER(S) SD-TR-89-91		
6a. NAME OF PERFORMING ORGANIZATION The Aerospace Corporation Laboratory Operations		6b. OFFICE SYMBOL (if applicable)	7a. NAME OF MONITORING ORGANIZATION Space Systems Division		
6c. ADDRESS (City, State, and ZIP Code) El Segundo, CA 90245-4691			7b. ADDRESS (City, State, and ZIP Code) Los Angeles Air Force Base Los Angeles, CA 90009-2960		
8a. NAME OF FUNDING/SPONSORING ORGANIZATION		8b. OFFICE SYMBOL (if applicable)	9. PROCUREMENT INSTRUMENT IDENTIFICATION NUMBER F04701-88-C-0089		
8c. ADDRESS (City, State, and ZIP Code)			10. SOURCE OF FUNDING NUMBERS		
		PROGRAM ELEMENT NO.	PROJECT NO.	TASK NO.	WORK UNIT ACCESSION NO.
11. TITLE (Include Security Classification) Determining the Effects of Microwave Power and C-Field Setting on the Frequency of a Cesium Atomic Frequency Standard					
12. PERSONAL AUTHOR(S) Karuza, Sarunas K.; Johnson, Walter A.; Voit, Frank J.					
13a. TYPE OF REPORT		13b. TIME COVERED FROM _____ TO _____		14. DATE OF REPORT (Year, Month, Day) 1989 December 31	15. PAGE COUNT 29
16. SUPPLEMENTARY NOTATION:					
17. COSATI CODES			18. SUBJECT TERMS (Continue on reverse if necessary and identify by block number)		
FIELD	GROUP	SUB-GROUP	→ Atomic clocks C-field tuning Cs atomic clocks		
19. ABSTRACT (Continue on reverse if necessary and identify by block number)					
In experiments at the United States National Institute of Standards and Technology, Andrea De Marchi showed that there exist optimum values of the C-field setting in a commercial dual-beam cesium frequency standard that make the output frequency insensitive to variations in microwave power. Moreover, and most important, De Marchi demonstrated that the long-term stability of the clock is improved if the C-field is set at one of these optimum settings. To see if these results can be obtained with a clock having a different modulation scheme, the authors, using a completely automated measuring system, performed a similar study on another manufacturer's commercial cesium standard; this standard employed single-beam tube optics and a modulation scheme different from that used by the clocks studied by De Marchi. Our results, similar to those of De Marchi, show that optimum C-field settings exist for the standard we investigated.					
20. DISTRIBUTION/AVAILABILITY OF ABSTRACT <input checked="" type="checkbox"/> UNCLASSIFIED/UNLIMITED <input type="checkbox"/> SAME AS RPT. <input type="checkbox"/> DTIC USERS			21. ABSTRACT SECURITY CLASSIFICATION Unclassified		
22a. NAME OF RESPONSIBLE INDIVIDUAL			22b. TELEPHONE (Include Area Code)		22c. OFFICE SYMBOL

PREFACE

The authors are grateful to David Allan and Andrea De Marchi of the National Institute of Standards and Technology, and to John Hurrell of The Aerospace Corporation, for their helpful and stimulating discussions on the subject of optimizing the C-field tuning of cesium frequency standards.



Accession For	
NTIS GRA&I	<input checked="" type="checkbox"/>
DTIC TAB	<input type="checkbox"/>
Unannounced	<input type="checkbox"/>
Justification	
By	
Distribution/	
Availability Codes	
Dist	Avail and/or Special
A-1	

CONTENTS

PREFACE..... 1

I. INTRODUCTION..... 7

II. MEASUREMENT SYSTEM..... 13

III. MEASUREMENT RESULTS..... 19

IV. INACCURACIES IN THE MEASUREMENT SYSTEM..... 25

V. CONCLUSIONS..... 27

REFERENCES..... 29

FIGURES

1.	The Difference in the Average Frequencies for Two Power Levels (P_0 and $P_0 + 1$ dB) as a Function of C-field in a Commercial Cs Frequency Standard.....	8
2.	The Measured Allan Standard Deviation of a Commercial Cs Frequency Standard at a Power-Sensitive C-Field Setting of 53 kHz.....	9
3.	The Measured Allan Standard Deviation of a Commercial Cs Frequency Standard at a Power-Insensitive (Zero Crossing) C-field Setting of 39 kHz.....	10
4.	Block Diagram of the C-field Measurement System for a Cs Frequency Standard.....	14
5.	Circuit Diagram of the Single Mixer-Frequency Measurement System Used to Determine the Fractional Frequency Changes at Different C-field Settings.....	15
6.	The Measured Allan Standard Deviation of the Commercial Cs Frequency Standard and the Noise Floor of the Frequency Measurement System.....	17
7.	A Plot of the Difference of the Average Frequencies as a Function of the C-field of a Commercial Cs Frequency Standard for Three Microwave Power Changes (-1, +1, and +3 dB) with Respect to the Optimum Power Level P_0	20
8.	Average of Final Data on the Difference of the Average Frequencies as a Function of C-field for a Microwave Power Change of +1 dB above the Optimum Power Level P_0	21
9.	The Measured Allan Standard Deviation of the Commercial Cs Frequency Standard at the Nonoptimum (Power-Sensitive) Zeeman Frequency Setting of 44 kHz.....	23
10.	The Measured Allan Standard Deviation of the Commercial Cs Frequency Standard at the Optimum (Power-Insensitive) Zeeman Frequency Setting of 37 kHz.....	24
11.	A Plot of Power Measurements Made during the C-field Experiment.....	26

I. INTRODUCTION

In a study of three cesium (Cs) frequency standards, Andrea De Marchi of the United States National Institute of Standards and Technology (NIST) has presented data^{1,2} that show one can improve the long-term frequency stability of such standards by selecting a value of Zeeman frequency (C-field) that reduces the standard's frequency sensitivity to variations in microwave power.

For example, Fig. 1, which is calculated from De Marchi's data,¹ is a plot of the fractional frequency change for a +1-dB change in microwave power as a function of the Zeeman frequency (f_z). It can be seen that there are four Zeeman frequencies (corresponding to four C-field settings) where the change in frequency will be zero for a change in microwave power of +1 dB. The peak-to-peak change in fractional frequency over the range of C-fields plotted is about 5×10^{-12} for this particular standard. De Marchi demonstrated that there was an improvement in the long-term frequency stability of the standard as measured by $\sigma_y(\tau)$, the Allan standard deviation, when the Zeeman frequency was set at these optimum values. Figures 2 and 3 from De Marchi's data¹ show $\sigma_y(\tau)$ as a function of τ for the two Zeeman frequencies of 53 and 39 kHz, respectively, with 39 kHz being an optimum frequency. It is clear that there is an improvement in the long-term frequency stability if the C-field value is set at 39 kHz.

De Marchi stated¹ that the results he had obtained on these Cs standards should be ". . . at least typical for all commercial standards . . ." He cautioned, however, that results obtained on Cs frequency standards that used different servo-loop schemes other than sine-wave or slow square-wave frequency modulation might be somewhat different. Consequently, considerable interest developed to determine if the stability of other Cs frequency standards using different modulation schemes could be improved by this technique of optimum C-field setting. Measurements similar to those of

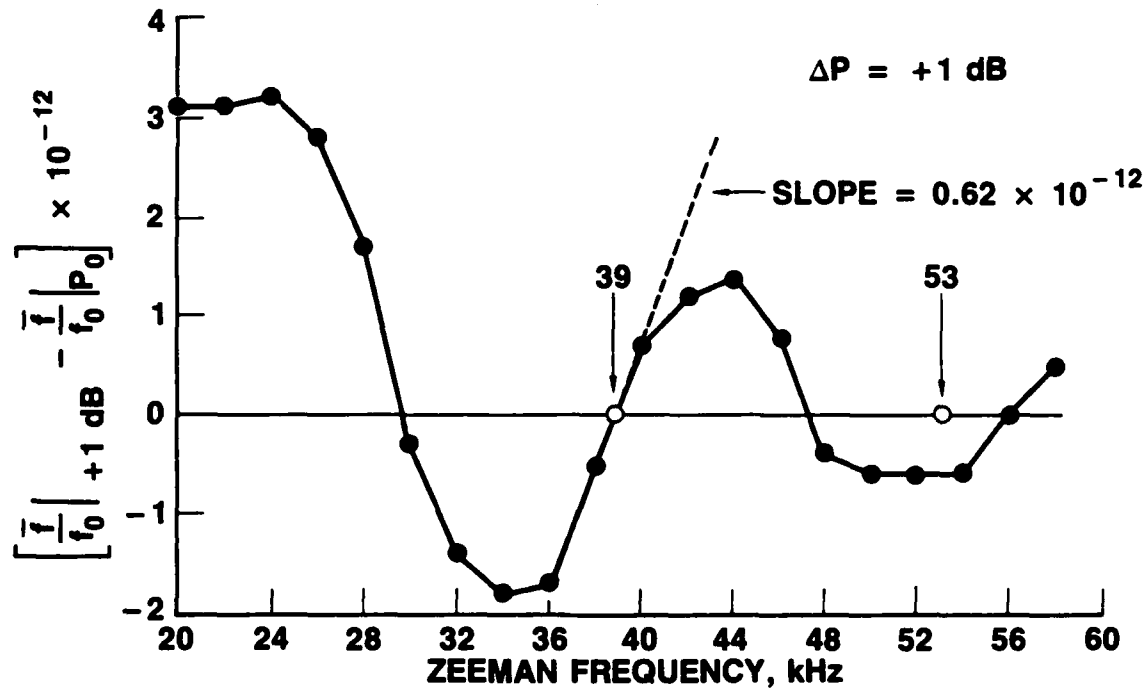

Fig. 1. The Difference in the Average Frequencies for Two Power Levels (P_0 and $P_0 + 1 \text{ dB}$) as a Function of C-field in a Commercial Cs Frequency Standard. Circles show points at a power-insensitive point (39 kHz) and a power-sensitive point (53 kHz). Data are taken from Ref. 1.

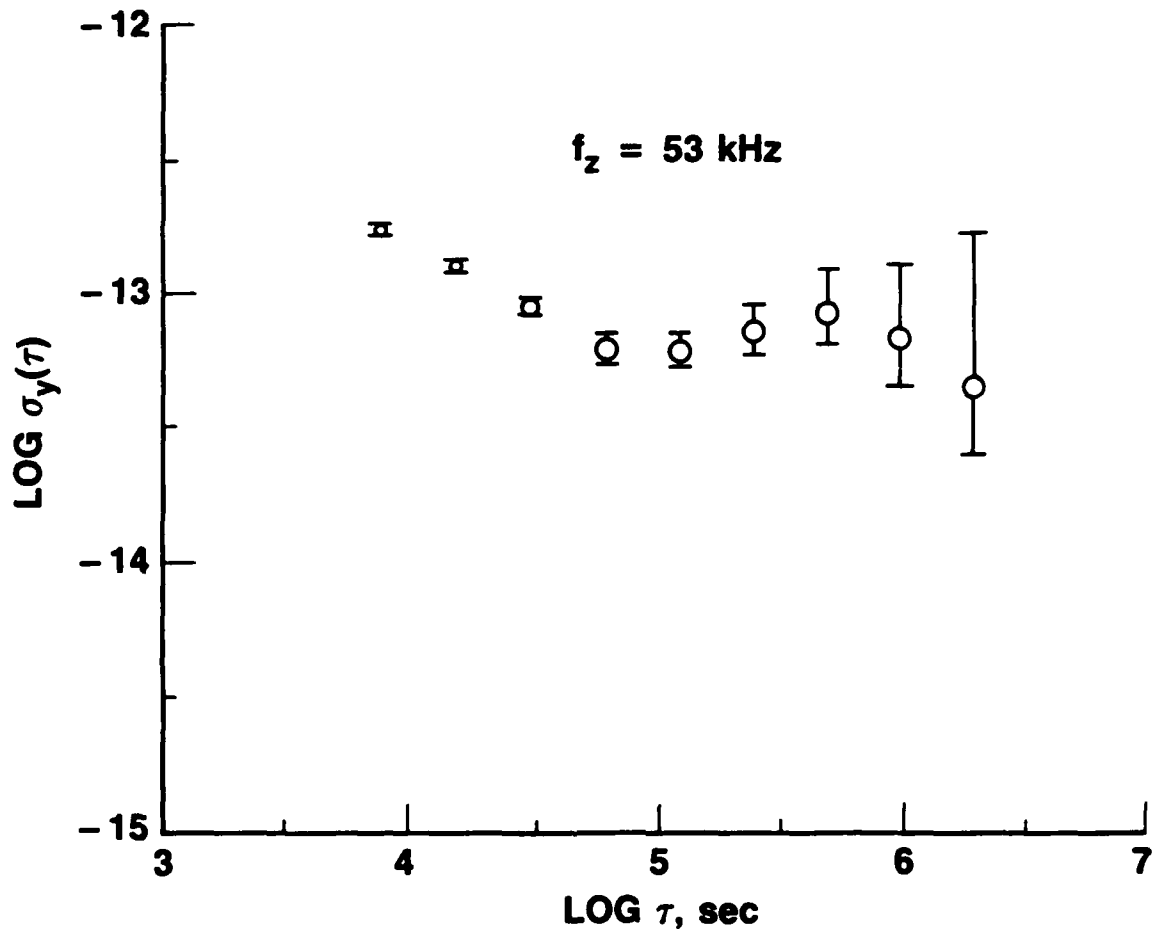

Fig. 2. The Measured Allan Standard Deviation of a Commercial Cs Frequency Standard at a Power-Sensitive C-field Setting of 53 kHz. Data are taken from Ref. 1.

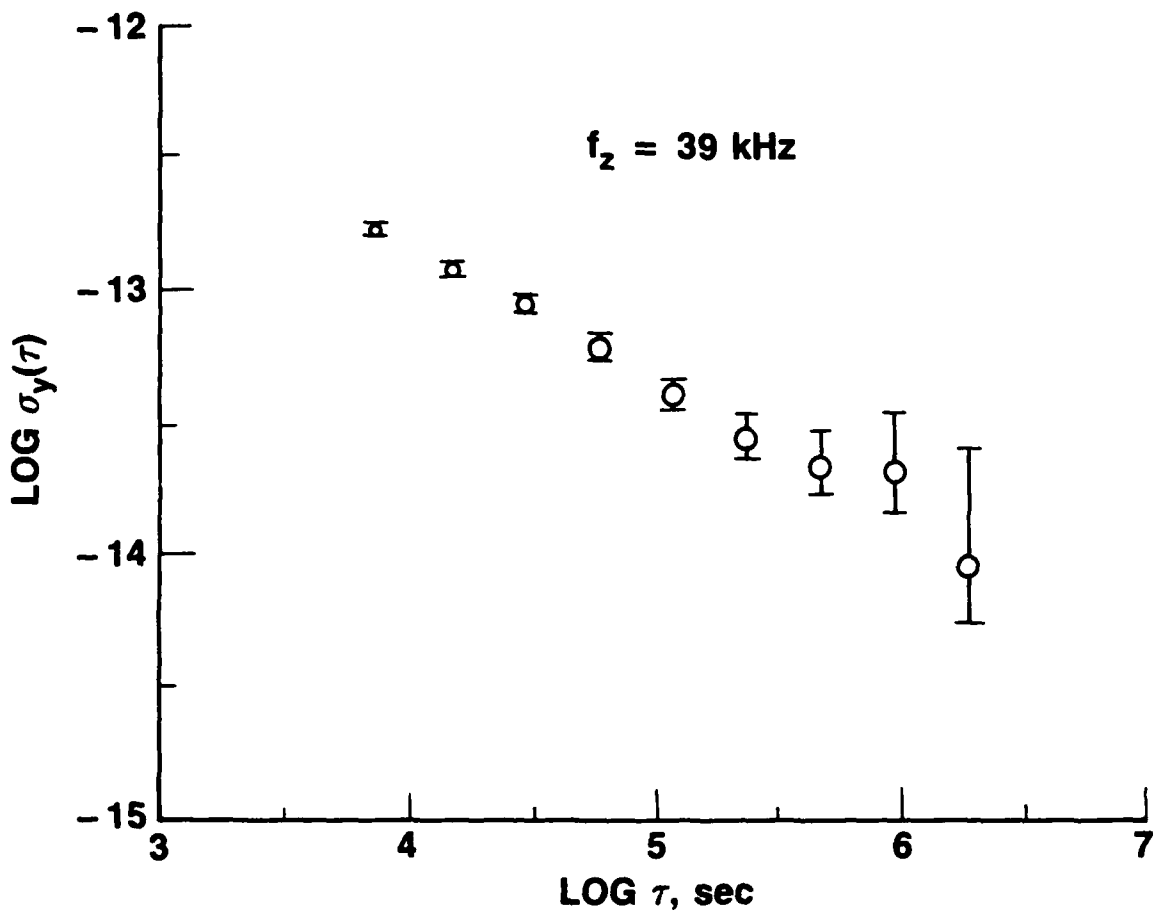

Fig. 3. The Measured Allan Standard Deviation of a Commercial Cs Frequency Standard at a Power-Insensitive (Zero Crossing) C-field Setting of 39 kHz. Data are taken from Ref. 1.

De Marchi were made in our own laboratory on a different manufacturer's Cs standard that used a different modulation scheme. Because the measurements are very time consuming, it was decided to automate them completely in order to maximize the data-taking time available. An additional advantage of this automation is that one never has to make and remake microwave power connections.

II. MEASUREMENT SYSTEM

The C-field experiment was performed in our laboratory on a different manufacturer's commercial Cs frequency standard that used a square-wave phase-modulation scheme. The standard was modified to allow access to the C-field coil wires and the microwave power source. Figure 4 shows the block diagram of the complete measurement system. Both of the parameters that are varied, namely the C-field current and the microwave power, are computer controlled; the current is set by a precision constant-current generator and the microwave power is changed by a calibrated PIN diode attenuator. The entire system is controlled by an HP series 300 computer, which also acquires and processes the data.

Figure 5 is a block diagram of the frequency measurement system. The frequency reference for both the Fluke synthesizer and the HP counter is an HP model 5061A-004 Cs frequency standard. Before the data are taken, the microwave tuning adjustments in the standard and the microwave power are varied to maximize the output current from the beam tube. The resulting microwave power is called the optimum power (P_0).

A typical data-taking sequence consisted of the following steps:

1. Set the C-field current at some low value (typically 6 to 8 mA) and the microwave power at some value (e.g. at the optimum value P_0).
2. Measure the beat frequency over some long averaging time T (typically 7000 sec).
3. Change the microwave power level (e.g. to $P_0 + 1$ dB).
4. Measure the beat frequency over T again.
5. Increase the C-field current by some programmed amount (typically 0.5 mA).
6. Measure the beat frequency over T again.
7. Change the microwave power back to the initial value.
8. Repeat steps 2 through 7 until the final C-field current (typically 20 to 25 mA) is reached.

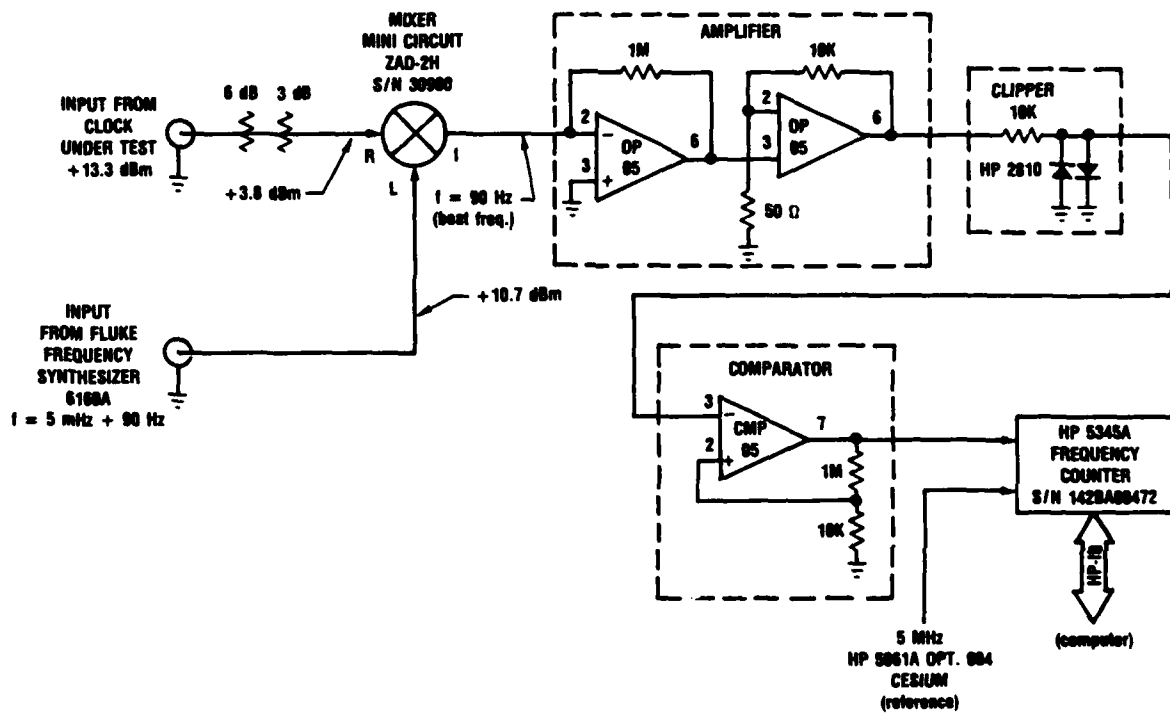

Fig. 5. Circuit Diagram of the Single Mixer-Frequency Measurement System Used to Determine the Fractional Frequency Changes at Different C-field Settings

Figure 6 shows a plot of the noise floor of the frequency measurement system and a plot of the frequency stability of the commercial Cs frequency standard used in our measurements.

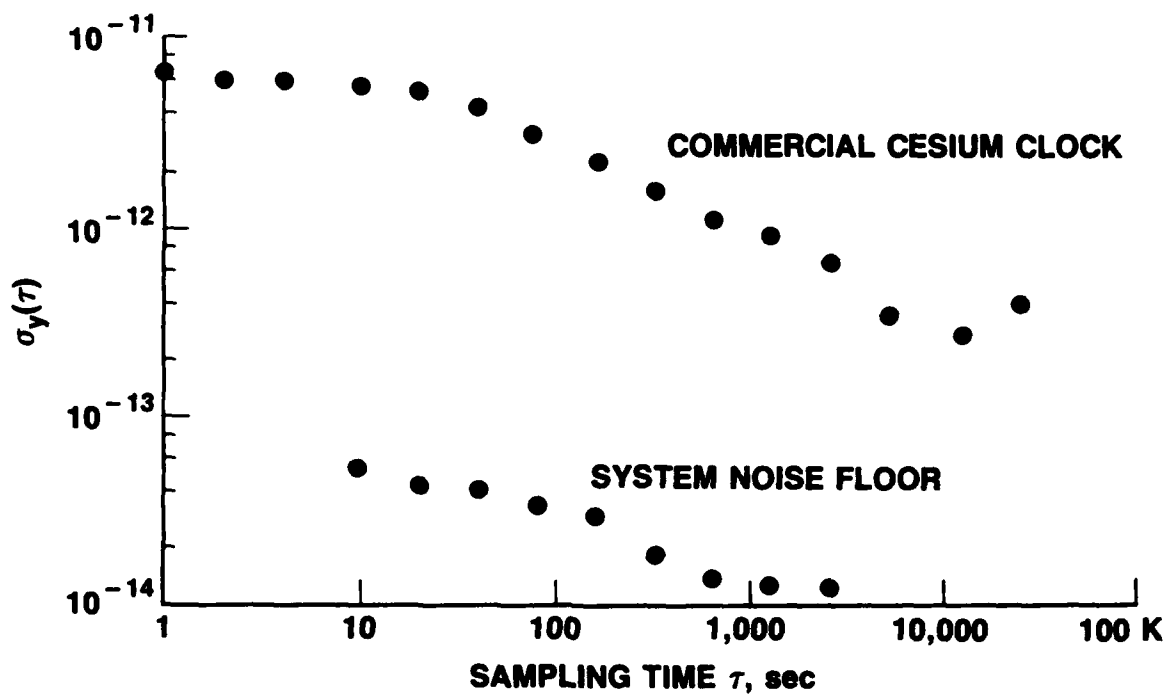

Fig. 6. The Measured Allan Standard Deviation of the Commercial Cs Frequency Standard and the Noise Floor of the Frequency Measurement System

III. MEASUREMENT RESULTS

Figure 7 shows the results of measurements made for changes in microwave power level of -1, +1, and +3 dB. For the -1-dB data, each point represents the difference between two 7000-sec samples; for the +1-dB data, each point represents the difference between two 14,000-sec samples; and for the +3-dB data, each point represents the difference between two 21,000-sec samples. Each data point is calculated as the difference in output frequency between the frequency at the higher power and the lower power, both of which are normalized to the nominal output. In other words,

$$\text{ordinate} = (\bar{f}_H - \bar{f}_L)/5 \text{ MHz}$$

where \bar{f}_H is the average output frequency for the higher microwave power and \bar{f}_L is the average output frequency for the lower microwave power. As Fig. 7 shows, for the +1-dB and -1-dB data there is a zero crossing at about 26 kHz, but it is difficult to see if there are any other zero crossings. For the +3-dB data it is clear that there are two zero crossings at about 25 and 37 kHz.

Because De Marchi had found multiple zero crossings for a +1-dB power change (Fig. 1), it was decided to spend the time to make a statistically significant measurement on our commercial Cs frequency standard for the same +1-dB change. Figure 8 shows the results of this measurement, with each data point representing the difference between two long samples (the error bars are ± 2 standard deviations). The sample lengths varied from 30,000 to 210,000 sec. These data show distinct zero crossings at about 25 and 37 kHz, in agreement with the earlier results for the larger power change of +3 dB. Thus, by using data for the 3-dB change, it may be possible to shorten greatly the amount of time it takes to determine the location of the 1-dB zero crossing. This could reduce the data-taking time to as few as two or three days.

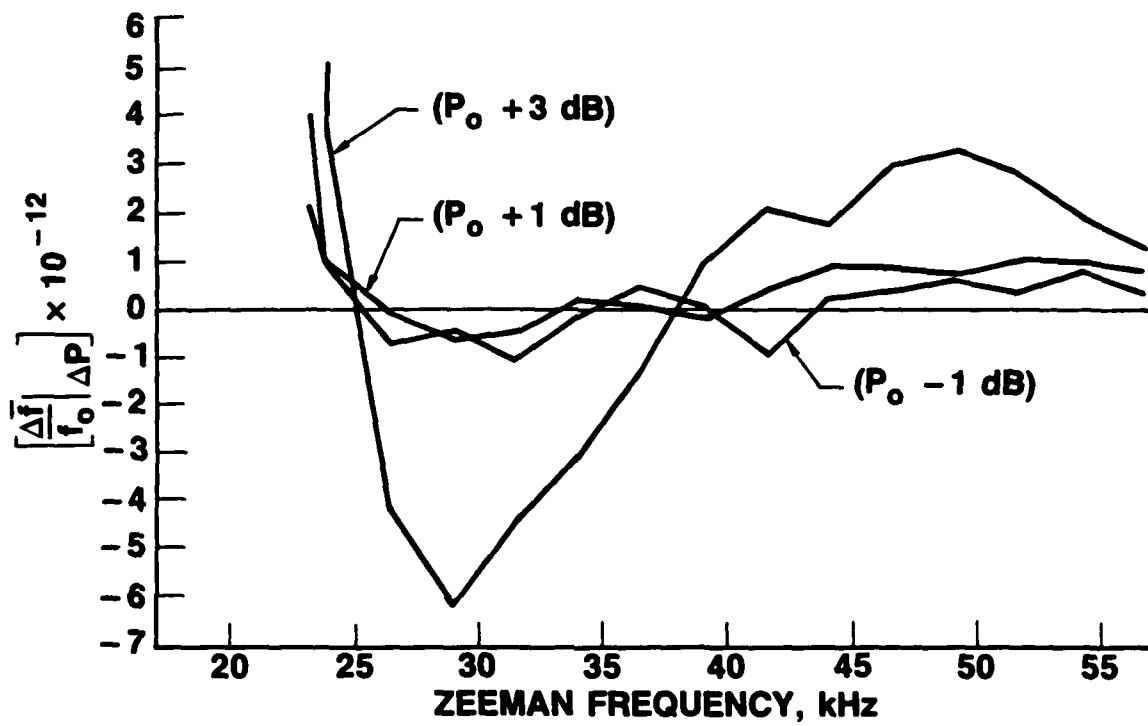

Fig. 7. A Plot of the Difference of the Average Frequencies as a Function of the C-field of a Commercial Cs Frequency Standard for Three Microwave Power Changes (-1, +1, and +3 dB) with Respect to the Optimum Power Level P_0

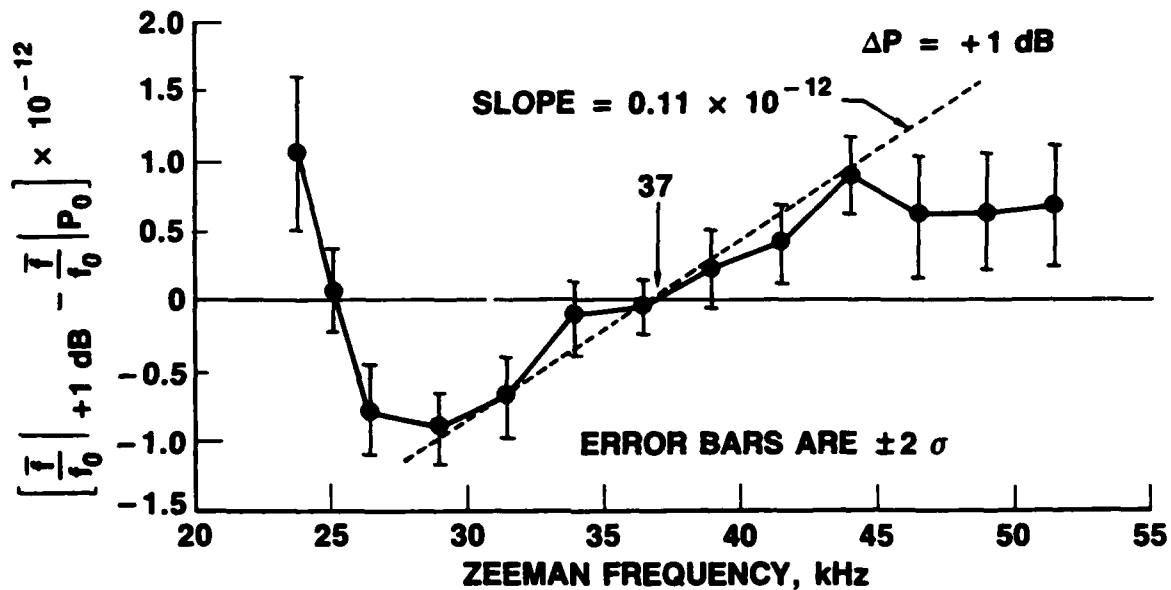

Fig. 8. Average of Final Data on the Difference of the Average Frequencies as a Function of C-field for a Microwave Power Change of +1 dB above Optimum Power Level P_0

As Fig. 8 shows, the slope at the 37-kHz zero crossing is $0.11 \times 10^{-12}/\text{kHz}$, compared to the slope of $0.62 \times 10^{-12}/\text{kHz}$ for the standard measured by De Marchi (Fig. 1). Thus for a given departure from the optimum Zeeman frequency, the frequency of our commercial Cs frequency standard would be from five to six times less sensitive to power changes than would be that of the HP standard. We caution that these data are for a small sample of clocks (three clocks in De Marchi's case and one from another manufacturer in our case), and may or may not be typical.

On October 11, 1988, our commercial Cs frequency standard was taken to the National Institute of Standards and Technology (NIST) at Boulder, Colorado, for an evaluation of the standard's long-term frequency stability at C-fields corresponding to Zeeman frequencies of 44 and 37 kHz, respectively, with 37 kHz being an optimum frequency. Figure 9 shows the long-term frequency stability data measured by NIST for the nonoptimum Zeeman frequency of 44 kHz, and Fig. 10 shows these data for the optimum Zeeman frequency of 37 kHz. The confidence intervals shown for both measurements are 95%. When Figs. 9 and 10 are compared, it is not statistically possible to say whether or not there is any improvement in long-term stability (as was clearly demonstrated for the clock in Figs. 2 and 3) as a result of setting the Zeeman frequency to the optimum value of 37 kHz. If anything, for the 37-kHz case it appears that the $\sigma_y(\tau)$ has reached a floor of about 3×10^{-13} for $\tau > 10^6$. We are presently in the process of making similar measurements on Cs frequency standards made by other manufacturers.

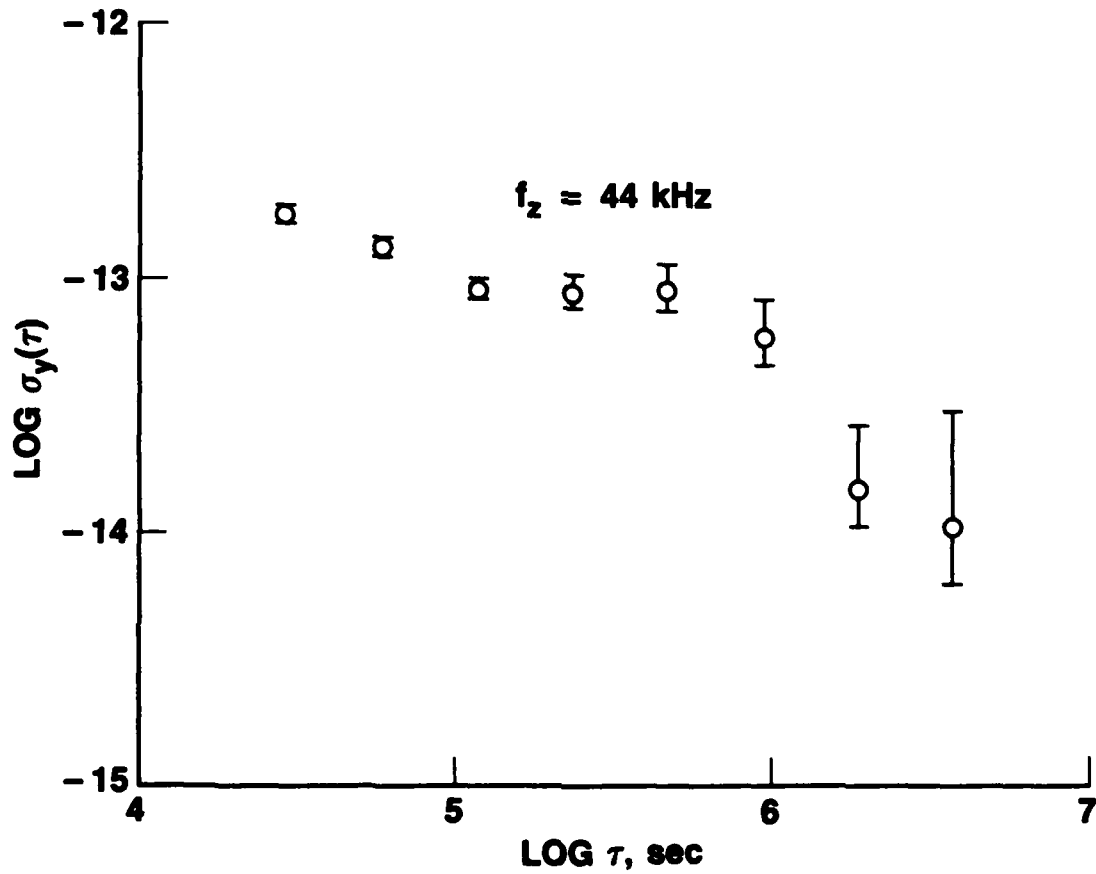

Fig. 9. The Measured Allan Standard Deviation of the Commercial Cs Frequency Standard at the Nonoptimum (Power-Sensitive) Zeeman Frequency Setting of 44 kHz. The confidence intervals are 95%. (Data taken by NIST.)

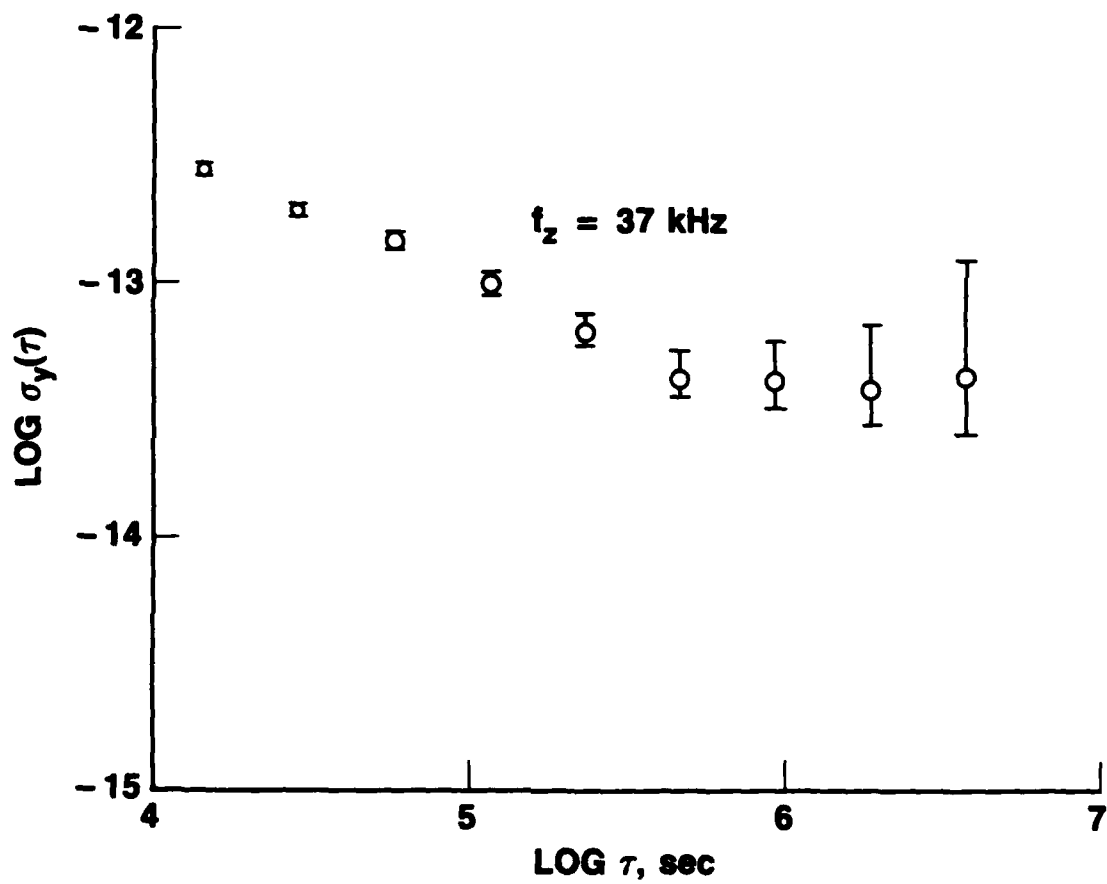

Fig. 10. The Measured Allan Standard Deviation of the Commercial Cs Frequency Standard at the Optimum (Power-Insensitive) Zeeman Frequency Setting of 37 kHz. The confidence intervals are 95%. (Data taken by NIST.)

IV. INACCURACIES IN THE MEASUREMENT SYSTEM

Our measurement system introduces three sources of error or uncertainty: (1) frequency measurement errors, (2) C-field current setting errors, and (3) power setting errors. The first error, as shown in Fig. 6, has been shown to be almost two orders of magnitude below the measurement data. The uncertainty of the C-field current setting is probably on the order of parts in 10^4 in our laboratory environment over the three months during which data were taken; this stability is largely set by the stability of a precision film resistor. The third source of uncertainty, the measurement of the microwave power, is the most difficult of the three to assess. Figure 11 shows the measured power over 21 days of the C-field measurement time. Separate stability measurements were made on the power meter and head over about two weeks; it was found that the noise in the measurement system, as measured by the standard deviation, was more than two orders of magnitude below the noise in the power measurements, as shown in Fig. 11. The data in this figure will be analyzed statistically and, in conjunction with the data in Fig. 8, will be used to calculate the effects of these power variations on the noise floor of the clock. The results of this effort will be published later.

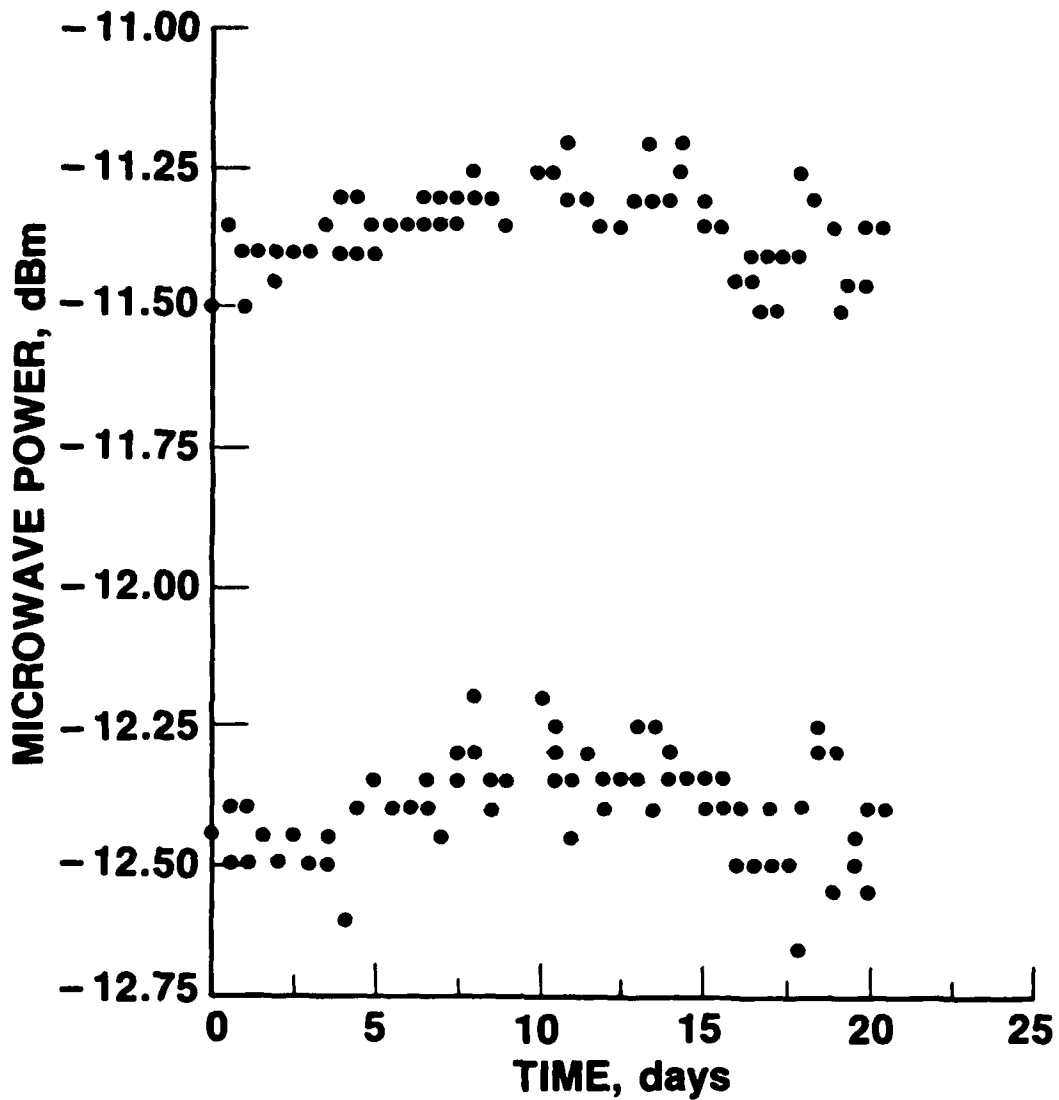

Fig. 11. A Plot of Power Measurements Made during the C-field Experiment. Power was switched between the two nominal levels of -11.35 and -12.35 dBm approximately every 0.14 days. The details of power switching are discussed in Section II.

V. CONCLUSIONS

The C-field experiment of De Marchi was performed on a commercial Cs frequency standard that used a square-wave phase-modulation scheme. The changes in microwave power level relative to the optimum power level (the power level that gives maximum beam current) were from -1 to +3 dB. The results showed that there were two optimum C-field levels that minimized the variations in output frequency caused by changes in microwave power. The Cs frequency standard was sent to NIST to determine if setting the C-field to this optimum (power-insensitive) value would improve the long-term frequency stability of the standard.

The data thus far do not show, within the statistical errors, that the long-term stability is improved by setting the C-field to an optimum value. Whether or not the measurements will be continued at NIST has not been decided as of the date of this report.

We must caution that the interpretation of our results is based on a study of only a single Cs frequency standard made by a single manufacturer. To confirm our preliminary findings, it is necessary not only to measure other standards of the type tested, but also those of other designs, with different modulation and servo-loop schemes, made by other manufacturers.

REFERENCES

1. A. De Marchi, "New Insights into Causes and Cures of Frequency Instabilities (Drift and Long-Term Noise) in Cesium Beam Frequency Standards," in Proc. 41st Frequency Control Symposium (Philadelphia, Pa., 1987), pp. 54-58.
2. A. De Marchi, "Rabi Pulling and Long-Term Stability in Cesium Beam Frequency Standards," IEEE Trans. Ultrasonics, Ferroelectrics, and Frequency Control UFFC-34 [6], 598-601 (November 1987).

LABORATORY OPERATIONS

The Aerospace Corporation functions as an "architect-engineer" for national security projects, specializing in advanced military space systems. Providing research support, the corporation's Laboratory Operations conducts experimental and theoretical investigations that focus on the application of scientific and technical advances to such systems. Vital to the success of these investigations is the technical staff's wide-ranging expertise and its ability to stay current with new developments. This expertise is enhanced by a research program aimed at dealing with the many problems associated with rapidly evolving space systems. Contributing their capabilities to the research effort are these individual laboratories:

Aerophysics Laboratory: Launch vehicle and reentry fluid mechanics, heat transfer and flight dynamics; chemical and electric propulsion, propellant chemistry, chemical dynamics, environmental chemistry, trace detection; spacecraft structural mechanics, contamination, thermal and structural control; high temperature thermomechanics, gas kinetics and radiation; cw and pulsed chemical and excimer laser development including chemical kinetics, spectroscopy, optical resonators, beam control, atmospheric propagation, laser effects and countermeasures.

Chemistry and Physics Laboratory: Atmospheric chemical reactions, atmospheric optics, light scattering, state-specific chemical reactions and radiative signatures of missile plumes, sensor out-of-field-of-view rejection, applied laser spectroscopy, laser chemistry, laser optoelectronics, solar cell physics, battery electrochemistry, space vacuum and radiation effects on materials, lubrication and surface phenomena, thermionic emission, photo-sensitive materials and detectors, atomic frequency standards, and environmental chemistry.

Computer Science Laboratory: Program verification, program translation, performance-sensitive system design, distributed architectures for spaceborne computers, fault-tolerant computer systems, artificial intelligence, micro-electronics applications, communication protocols, and computer security.

Electronics Research Laboratory: Microelectronics, solid-state device physics, compound semiconductors, radiation hardening; electro-optics, quantum electronics, solid-state lasers, optical propagation and communications; microwave semiconductor devices, microwave/millimeter wave measurements, diagnostics and radiometry, microwave/millimeter wave thermionic devices; atomic time and frequency standards; antennas, rf systems, electromagnetic propagation phenomena, space communication systems.

Materials Sciences Laboratory: Development of new materials: metals, alloys, ceramics, polymers and their composites, and new forms of carbon; non-destructive evaluation, component failure analysis and reliability; fracture mechanics and stress corrosion; analysis and evaluation of materials at cryogenic and elevated temperatures as well as in space and enemy-induced environments.

Space Sciences Laboratory: Magnetospheric, auroral and cosmic ray physics, wave-particle interactions, magnetospheric plasma waves; atmospheric and ionospheric physics, density and composition of the upper atmosphere, remote sensing using atmospheric radiation; solar physics, infrared astronomy, infrared signature analysis; effects of solar activity, magnetic storms and nuclear explosions on the earth's atmosphere, ionosphere and magnetosphere; effects of electromagnetic and particulate radiations on space systems; space instrumentation.