

NAVAL POSTGRADUATE SCHOOL

Monterey, California

AD-A216 841



THESIS

SHIP'S ATTITUDE ESTIMATION

by

Jose F. Garcia III

June 1989

Thesis Advisor

Harold A. Titus

Approved for public release; distribution is unlimited.

cy

9 0 01 17 130

Unclassified

security classification of this page

REPORT DOCUMENTATION PAGE

1a Report Security Classification Unclassified		1b Restrictive Markings	
2a Security Classification Authority		3 Distribution Availability of Report Approved for public release; distribution is unlimited.	
2b Declassification Downgrading Schedule			
4 Performing Organization Report Number(s)		5 Monitoring Organization Report Number(s)	
6a Name of Performing Organization Naval Postgraduate School	6b Office Symbol <i>(if applicable)</i> 62	7a Name of Monitoring Organization Naval Postgraduate School	
6c Address <i>(city, state, and ZIP code)</i> Monterey, CA 93943-5000		7b Address <i>(city, state, and ZIP code)</i> Monterey, CA 93943-5000	
8a Name of Funding Sponsoring Organization	8b Office Symbol <i>(if applicable)</i>	9 Procurement Instrument Identification Number	
8c Address <i>(city, state, and ZIP code)</i>		10 Source of Funding Numbers	
		Program Element No	Project No
		Task No	Work Unit Accession No
11 Title <i>(include security classification)</i> SHIP'S ATTITUDE ESTIMATION			
12 Personal Author(s) Jose F. Garcia III			
13a Type of Report Master's Thesis	13b Time Covered From To	14 Date of Report <i>(year, month, day)</i> June 1989	15 Page Count 49
16 Supplementary Notation The views expressed in this thesis are those of the author and do not reflect the official policy or position of the Department of Defense or the U.S. Government.			
17 Cosati Codes		18 Subject Terms <i>(continue on reverse if necessary and identify by block number)</i>	
Field	Group	Subgroup	Ship Motion, Kalman Filter, Computer Simulations, Thesis
19 Abstract <i>(continue on reverse if necessary and identify by block number)</i>			
<p>Landing aircraft on board carriers is a most delicate phase of flight operations at sea. The ability to predict the aircraft carrier's motion over an interval of several seconds within reasonable error bounds may allow improvement in touchdown dispersion and a more certain value for a ramp clearance due to a smoother aircraft trajectory. Also, improved information to the Landing Signal Officer should decrease the number of waveoffs.</p> <p>This work indicates and shows graphically that, based on the data for pitch, heave and roll measured for various ships and sea conditons. the motion can be predicted well. The predictor was designed on the basis of Kalman's optimum filtering theory for the discrete time case, adapted for real-time digital computer operation.</p>			
20 Distribution Availability of Abstract		21 Abstract Security Classification	
<input checked="" type="checkbox"/> unclassified unlimited <input type="checkbox"/> same as report <input type="checkbox"/> DTIC users		Unclassified	
22a Name of Responsible Individual Harold A. Titus		22b Telephone <i>(include Area code)</i> (408) 646-2560	22c Office Symbol 62TS

Approved for public release; distribution is unlimited.

Ship's Attitude Estimation

by

Jose F. Garcia III
Lieutenant, United States Navy
B.S.E.E., University Of The East, Philippines, 1976

Submitted in partial fulfillment of the
requirements for the degree of

MASTER OF SCIENCE IN ELECTRICAL ENGINEERING

from the

NAVAL POSTGRADUATE SCHOOL
June 1989

Author:



Jose F. Garcia III

Approved by:

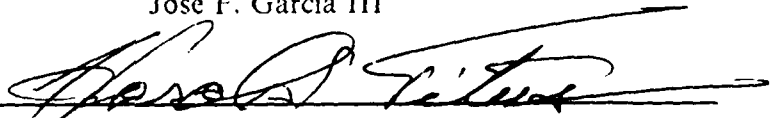

Harold A. Titus, Thesis Advisor

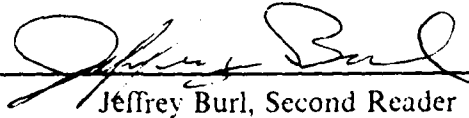

Jeffrey Burl, Second Reader

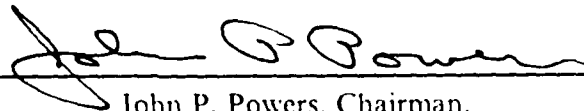

John P. Powers, Chairman,
Department of Electrical and Computer Engineering



Gordon E. Schacher,
Dean of Science and Engineering

ABSTRACT

Landing aircraft on board carriers is a most delicate phase of flight operations at sea. The ability to predict the aircraft carrier's motion over an interval of several seconds within reasonable error bounds may allow improvement in touchdown dispersion and a more certain value for a ramp clearance due to a smoother aircraft trajectory. Also, improved information to the Landing Signal Officer should decrease the number of waveoffs.

This work indicates and shows graphically that, based on the data for pitch, heave and roll measured for various ships and sea conditions, the motion can be predicted well. The predictor was designed on the basis of Kalman's optimum filtering theory for the discrete time case, adapted for real-time digital computer operation.

App...	
LT...	X
EL...	
U...	
S...	
By...	
Dist...	
A...	
Dist...	
A-1	

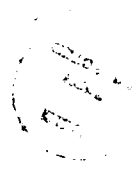

TABLE OF CONTENTS

I. INTRODUCTION	1
II. PROBLEM STATEMENT	3
A. GENERAL	3
B. SHIP MOTION	3
C. SYSTEM MODEL	5
D. MEASUREMENT MODEL	6
III. KALMAN FILTER THEORY	9
A. GENERAL	9
B. NOISE PROCESSES	10
C. INITIALIZATION AND OPERATION	10
IV. COMPUTER SIMULATIONS	15
A. GENERAL	15
V. CONCLUSIONS	26
APPENDIX A. MATLAB PROGRAM 1	27
APPENDIX B. MATLAB PROGRAM 2	31
APPENDIX C. MATLAB PROGRAM 3	36
LIST OF REFERENCES	41
INITIAL DISTRIBUTION LIST	42

LIST OF FIGURES

Figure 1.	The x, y, and z-axes of a ship	4
Figure 2.	White Noise Model	7
Figure 3.	Ship Motion Model Block Diagram	8
Figure 4.	Ship Motion Model Diagram With Estimator	13
Figure 5.	Ship's Motion Predictor Block Diagram	14
Figure 6.	Swell Wave Motion with a Height of 11 feet	16
Figure 7.	Ship's Heave Motion caused by 11 feet high of Swell	17
Figure 8.	Ship's Pitch Motion caused by 11 feet high of Swell	18
Figure 9.	Ship's Roll Motion caused by 11 feet high of Swell	19
Figure 10.	Observed and Estimated Heave Motion	20
Figure 11.	Observed and Estimated Pitch Motion	21
Figure 12.	Observed and Estimated Roll Motion	22
Figure 13.	Observed and Predicted Heave Motion	23
Figure 14.	Observed and Predicted Pitch Motion	24
Figure 15.	Observed and Predicted Roll Motion	25

ACKNOWLEDGEMENTS

I would like to express my sincere appreciation to Dr. Harold A. Titus for his professional guidance, assistance and encouragement during the pursuit of this study. Also, I wish to thank my wife and our sons, for their love, support, patience and understanding through my busy schedules at the Naval Postgraduate School.

I. INTRODUCTION

The landing phase of VTOL, STOL and HELO aircraft aboard a ship without a ship's Inertial Navigational System represents a complex operation and a demanding task. The last 10 to 15 seconds before the aircraft touchdown involves terminal guidance and control problems, where not only the aircraft is disturbed by several kinds of stochastic disturbances (wind), but also the touchdown point (on the ship) is being moved randomly. Despite the wind disturbances and the final point (target) random motion, the landing accuracy specified for ship operations is very high, i.e., a few tens of feet longitudinal landing dispersion. Such a terminal point problem is made tractable in a most natural way by assuming that the ship's position can be predicted for several seconds ahead so that the aircraft is guided toward the future position of the touchdown point. The scope of this study was to establish to what extent a stochastic process, like the ship's motion, is predictable over moderate periods of time.

Graphical results obtained throughout this estimator's feasibility study concerning the relationship between the ship's states: heave, pitch and roll versus the ship's estimated states; heave, pitch and roll; and the influence of noise measurement are presented. Digital simulations show that the prediction accuracy was very accurate for different swell wave height and period. The feasibility of estimating the ship's motion of acceptable bounds of error can also lead to improvement of the Landing Signal Officer's (LSO) decision policy for waveoffs.

This study was based on the use of the ship's motion equations and the simulated measuring instrumentations existing on board ship in order to get the predicted motions. Using this information, a predictor based on Kalman's theory of optimum estimation was designed.

Several circumstances contributed to the success of this approach. The size and mass of the ship significantly filter the motion of the sea. A complete landing operation is short enough that the stochastic processes are reasonably taken to be stationary. Finally, the prediction interval is only a small fraction of the time it takes each aircraft for final approach.

This work is divided into three parts: 1) the derivation of the mathematical model of the ship's motion, 2) the rationale in the implementation of Kalman filter and predictor equations, and 3) discussion of the simulated computer results obtained. Since

we are interested only in the most critical aspects of the landing operation, namely the characteristics of the longitudinal channel, we merely investigate in the sequel the predictability of the heave, pitch and roll motion of the ship where yaw is omitted.

II. PROBLEM STATEMENT

A. GENERAL

The ship's attitude estimation used in this thesis involves calculation of heave, pitch and roll of the ship moving in the general direction towards a swell while recovering an aircraft. The motion of the ship is given in z , θ and ϕ coordinates as shown in Figure 1.

This problem will be developed using state space methods. Given the heave, pitch and roll motion (the measurements) received through the ship's sensor system, we are interested in estimating the heave, pitch and roll of the ship. The state variables for this plant are z_h , \dot{z}_h , θ_p , $\dot{\theta}_p$, ϕ_r and $\dot{\phi}_r$.

B. SHIP MOTION

A ship moving on the surface of the sea is almost always in oscillatory motion. The different kinds of oscillatory motions that a ship experiences can be described with the help of Figure 1, which shows the six kinds of motion, three linear and three rotational about the principal axes. Accordingly,

The six kinds of ship's motions are:

1. a = **surging** -- motion backwards in the direction of the ship travel.
2. b = **swaying** -- athwartship motion of the ship.
3. c = **heaving** -- motion vertically up and down.
4. d = **rolling** -- angular motion about the longitudinal axis. When the ship rolls, it lists alternately from starboard to port and then back to starboard.
5. e = **pitching** -- angular motion about the transverse axis. When a ship pitches, it trims alternately by the bow and by the stern.
6. f = **yawing** -- angular motion about the vertical axis.

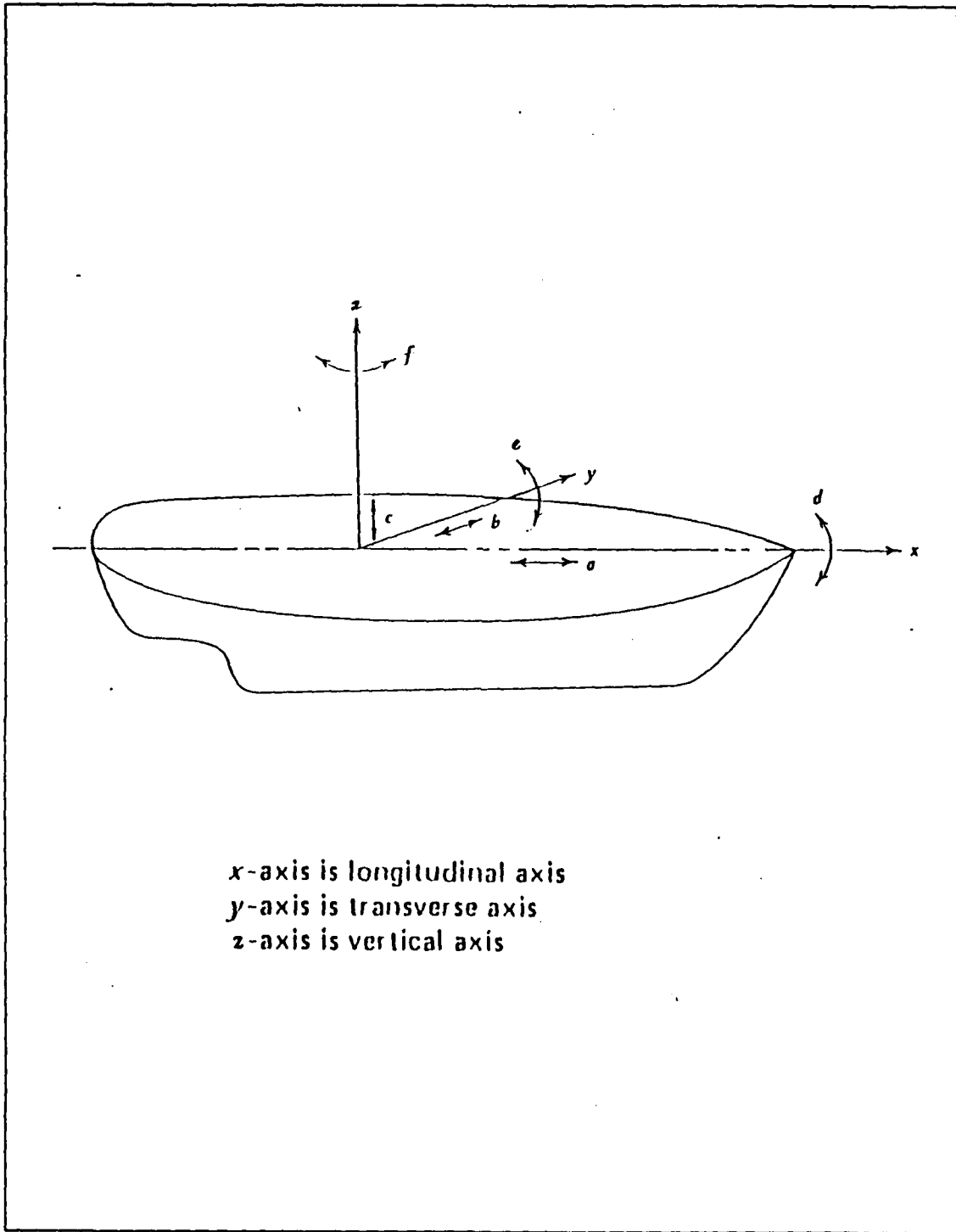

Figure 1. The x, y, and z-axes of a ship

Only three kinds of motion, namely heaving, pitching and rolling (z , θ , ϕ) are purely oscillatory motions, since these motions act under a restoring force or moment when the ship is disturbed from its equilibrium position. These ship motions are the only motions being considered in this thesis.

Although in reality a ship experiences all six kinds of motion simultaneously, only one motion of the three angular motions will be treated at a time in the following sections. However, one must bear in mind that any one kind of motion is not independent of the others; in the first approximation, coupling between the motions is neglected in order to simplify the problem.

C. SYSTEM MODEL

The system to be modeled in this problem is the motion of a surface ship at sea during an aircraft recovery phase. This is a linear, time-angle system that can be described in a discrete equation of ship motion . The state space equation is

$$\underline{x}_{k+1} = \Phi_k \underline{x}_k + \Gamma_k u_k \quad (2.1)$$

where

\underline{x}_k = parameter to be estimated (state vector) heave, pitch and roll

Φ_k = state transition matrix which describes how the states of the dynamic system are related.

Γ_k = system random uncorrelated coefficient matrix.

u_k = sequence of random uncorrelated inputs.

From Equation (2.1) and the above assumptions, the state vector for heave, pitch and roll is

$$\underline{x}_k = \begin{bmatrix} z \\ \dot{z} \\ \theta \\ \dot{\theta} \\ \phi \\ \dot{\phi} \end{bmatrix} \quad (2.2)$$

and the system state equation can be approximated for $T \ll 1$

$$\begin{bmatrix} z \\ \dot{z} \\ \theta \\ \dot{\theta} \\ \phi \\ \dot{\phi} \end{bmatrix}^{k+1} = \begin{bmatrix} 1 & T & 0 & 0 & 0 & 0 \\ -c_z & 1-b_z & 0 & 0 & 0 & 0 \\ 0 & 0 & 1 & T & 0 & 0 \\ 0 & 0 & -c_p & 1-b_p & 0 & 0 \\ 0 & 0 & 0 & 0 & 1 & T \\ 0 & 0 & 0 & 0 & -c_r & 1-b_r \end{bmatrix} \begin{bmatrix} z \\ \dot{z} \\ \theta \\ \dot{\theta} \\ \phi \\ \dot{\phi} \end{bmatrix}^{k+} + \begin{bmatrix} 0 & 0 & 0 \\ Tg_z & 0 & 0 \\ 0 & 0 & 0 \\ 0 & Tg_p & 0 \\ 0 & 0 & 0 \\ 0 & 0 & Tg_r \end{bmatrix} [u_k] \quad (2.3)$$

where

$u_k = \zeta_a \cos \omega_s t + \text{plant noise}$

$\zeta_a = \text{swell wave amplitude}$

$\omega_s = \text{swell angular frequency}$

$c_z = g_z = \text{heaving restoring force coefficient}$

$b_z = \text{heaving damping force coefficient}$

$c_p = g_p = \text{pitching restoring moment coefficient}$

$b_p = \text{pitching damping moment coefficient}$

$c_r = g_r = \text{rolling restoring moment coefficient}$

$b_r = \text{heaving damping moment coefficient.}$

The system noise process for the ship motion estimation problem is a function of the random uncorrelated coefficient matrix, Γ_k , and the random forcing function, u_k .

D. MEASUREMENT MODEL

For a linear measurement process, the measurements are linearly related to the state variables and can be modeled using the linear measurement equation

$$z_k = H_k x_k + \epsilon_k \quad (2.4)$$

where

$z_k = \text{set of measurements.}$

$H_k = \text{observation matrix that gives the noiseless relationship between the measurements and the state vector.}$

$x_k = \text{state vector}$

$\epsilon_k = \text{sequence of random uncorrelated measurement noise.}$

In this ship motion estimation problem, the measurements are the heave, pitch and roll angles taken from the ship sensors.

$$z_k = [1 \ 0]x_k + v_k \quad (2.5)$$

The linear equation with the measurement data available can now be processed with the Kalman filter. The type of noise that affect the ship motion data are assumed to be white gaussian noise. This noise model was used in the computer simulations and shown in Figure 2, with zero mean and variance of one.

The complete development of this model can be found in Bhattacharyya [Ref. 1: pp.35-180], Wah [Ref. 2: pp.31-47], Korvin- Kroukovsky [Ref. 3] and Blagoveshchensky [Ref. 4].

The corresponding block diagram of the system is shown in Figure 3.

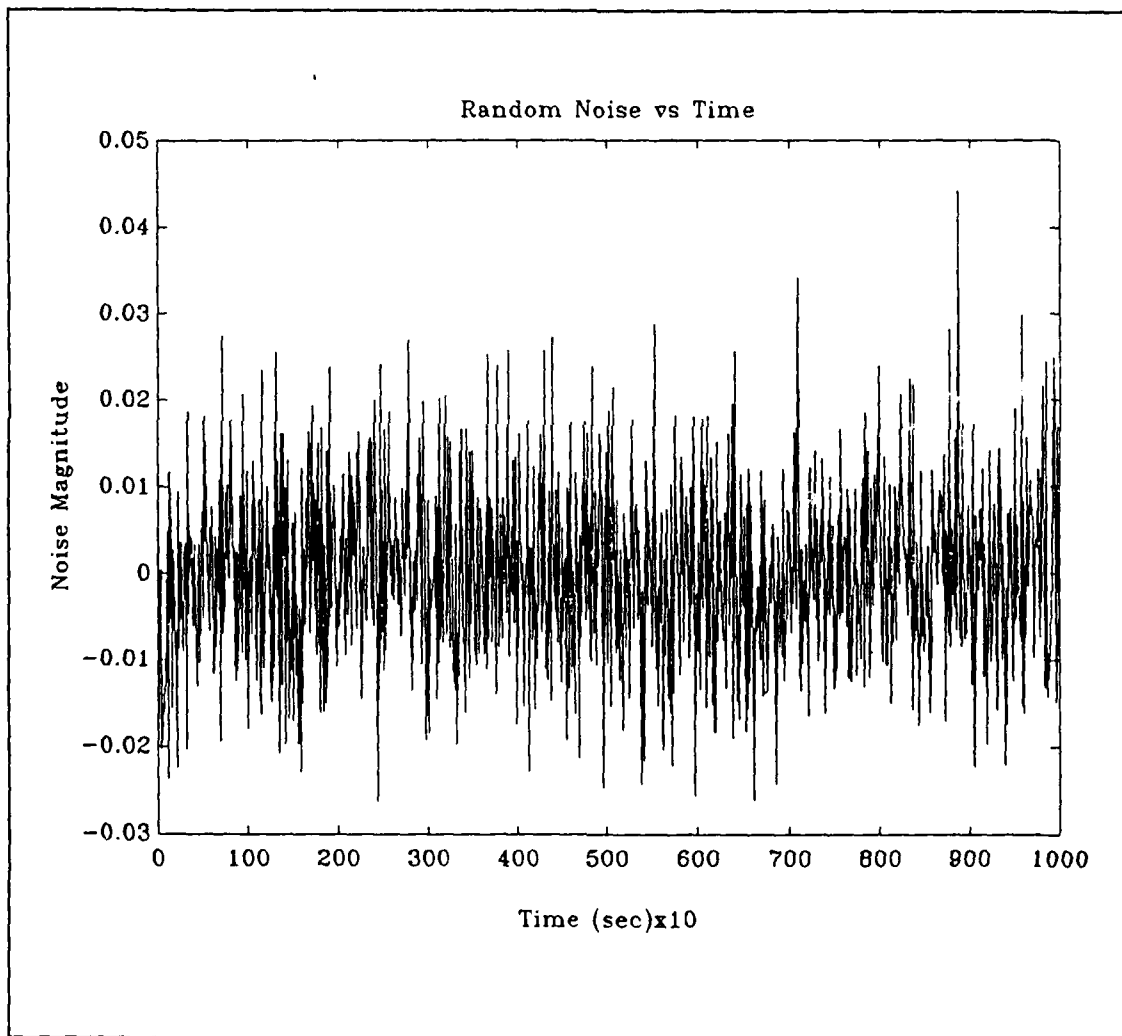

Figure 2. White Noise Model

SYSTEM STATE BLOCK DIAGRAM

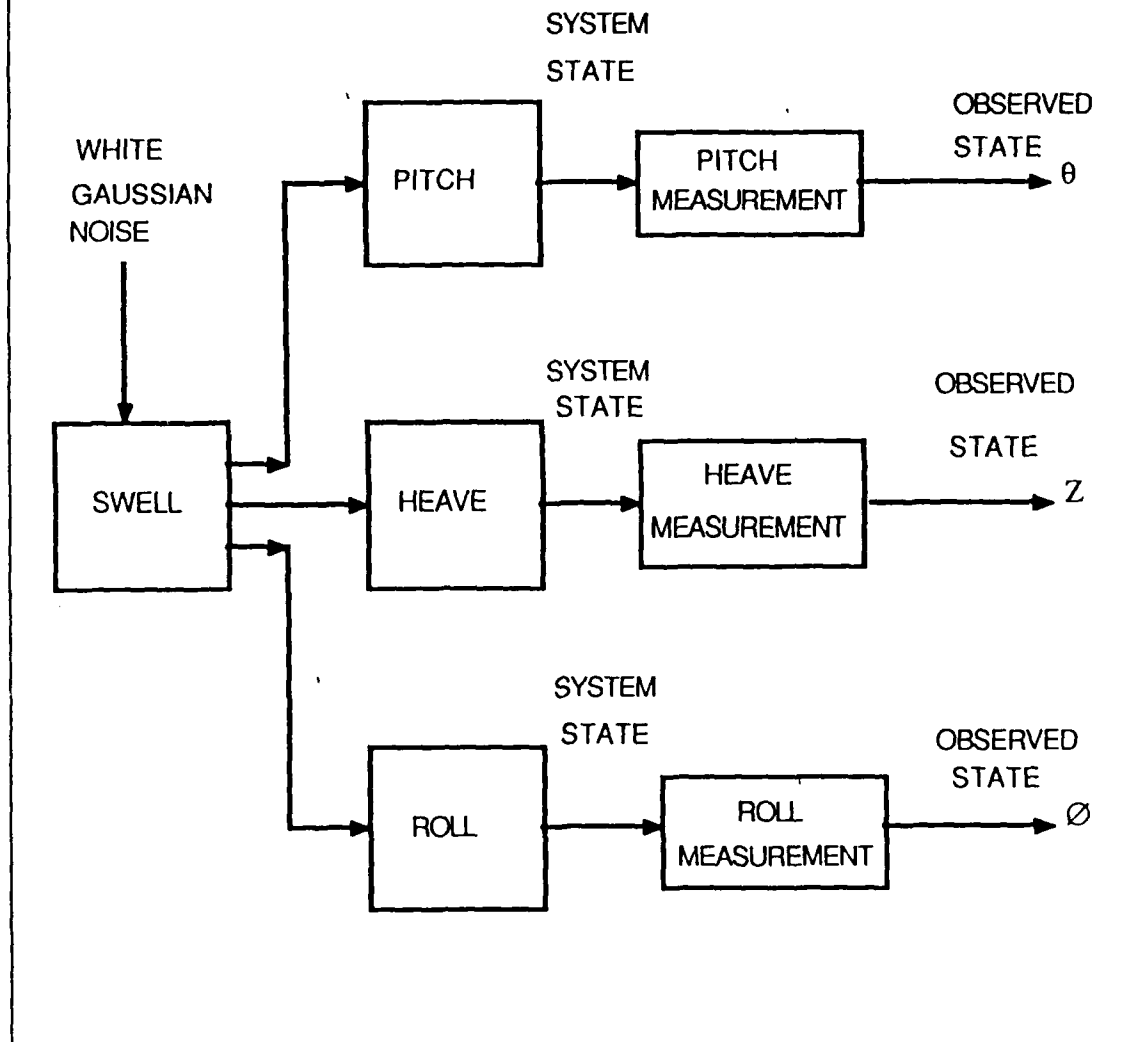

Figure 3. Ship Motion Model Block Diagram

III. KALMAN FILTER THEORY

A. GENERAL

Filtering refers to the process of estimating the state vector at the current time based upon all past measurements. An optimal filter concentrates on optimizing a specific performance measure used to determine the quality of the estimate. The Kalman filter is an optimal filter in a class of linear filters that minimize the mean square estimation error between the actual and desired output. In other words, the Kalman filter attempts to minimize the elements along the main diagonal of the state error covariance matrix. The filter is a recursive algorithm for processing discrete measurements or observations in an optimal manner, [Ref. 5: p. 101] and [Ref. 6]. It requires a priori knowledge of the state estimate (\underline{x}_{k-1}) and its error covariance (P_{k-1}), and the current observation (\underline{z}_k). The Kalman filter is the proper algorithm to be used when both the system model and the measurement model are linear functions of the state variables and these models can be described by the equations

$$\underline{x}_{k+1} = \Phi_k \underline{x}_k + \Gamma_k \underline{u}_k \quad (3.1)$$

$$\underline{z}_k = H_k \underline{x}_k + \underline{v}_k \quad (3.2)$$

In this equation, Φ_k and Γ_k are constant matrices and H_k is a linear constant function of the state variable \underline{x}_k , while \underline{u}_k is the random forcing function and \underline{v}_k is the measurement noise. The plant random forcing function and measurement noise are assumed to be uncorrelated (white Gaussian) with zero mean. That is

$$E[w(k) \cdot w^T(j)] = Q'(k) \delta_{kj} \quad (3.3)$$

and

$$E[v(k) \cdot v^T(j)] = R'(k) \delta_{kj} \quad (3.4)$$

where

$$\begin{aligned} \delta_{kj} &= 1, \quad k = j \\ &= 0, \quad k \neq j \end{aligned} \quad (3.5)$$

B. NOISE PROCESSES

The calculation of the error covariance matrix and the filter gain matrix requires the covariance matrices for the uncorrelated noise process u_k and v_k . For the measurement noise process, v_k , the covariance matrix is

$$E[v_k v_k^T] = R_k \quad (3.6)$$

where R_k is defined as the state measurement noise covariance matrix. It is based on the sensor accuracy and accounts for unknown disturbances such as steps, white noise, or imperfections in the plant model. The variance of the white noise model used in the computer simulations was one.

The state excitation matrix, Q_k , used in the Kalman filter represents the system noise process and is a function of the system noise coefficient matrix, Γ_k , and the random forcing function, u_k . This matrix is given by

$$Q_k = [\Gamma_k Q'_k \Gamma_k^T] \quad (3.7)$$

where Γ_k is the same as in Equation (2.3). The Q_k matrix allows for any random heave, pitch and roll ship motion well as inaccuracies in the system model. The magnitude of Q_k has a direct bearing on the magnitude of the state error covariance matrix and it prevents the covariance matrix from becoming singular by ensuring some uncertainty in the state estimates.

C. INITIALIZATION AND OPERATION

In the ship motion estimation, Kalman filters are used to minimize the ship's attitude errors. Prior to processing the measurement data, the filter must be initialized with an initial state estimate and an initial error covariance matrix. This initialization process is a very important step in the filter operation and gross inaccuracies in this step may cause the filter to diverge. Divergence occurs when the calculated covariance errors become much smaller than the actual covariance errors. This causes the estimate values of the states to pull away from the actual value and is also used as a startup value for the recursive scheme.

The basic operation of the filter is a relatively straightforward recursive process. Based on Kirk [Ref. 6 : pp.4-1, 4-62] and Gelb [Ref. 5], the discrete time version of equations used in the Kalman filter are:

$$\hat{x}_{(k|k-1)} = \phi_k \hat{x}_{(k|k)} \quad (3.8)$$

$$P_{(k|k-1)} = \phi_k P_{(k|k)} \phi_k^T + Q_k \quad (3.9)$$

$$G_k = P_{(k|k-1)} H_k^T (H_k P_{(k|k-1)} H_k^T + R_k)^{-1} \quad (3.10)$$

$$\hat{\mathbf{x}}_{(k|k)} = \hat{\mathbf{x}}_{(k|k-1)} + G_k (\mathbf{z}_k - H_k \hat{\mathbf{x}}_{(k|k-1)}) \quad (3.11)$$

$$P_{(k|k)} = (I - G_k H_k) P_{(k|k-1)} \quad (3.12)$$

where

$\hat{\mathbf{x}}_{(k|k-1)}$ = projected ahead state estimate

ϕ_k = state transition matrix given by Eq. (2.3)

$P_{(k|k-1)}$ = projected ahead state error covariance matrix

Q_k = state excitation covariance matrix given by Eq. (3.4)

G_k = Kalman gain matrix

R_k = state measurement noise covariance matrix given by Eq. (3.3)

H_k = linearized measurement matrix given by Eq. (2.5).

From the given equations, we can start the filter processing operation. The a priori state estimate are calculated using the Φ matrix shown in Equation (2.3) where T is the sampling time in seconds between the observed ship motions (heave, pitch and roll). (It is assumed ship motions are received simultaneously through the ship sensors.)

The Kalman gain matrix serves to minimize the mean square estimation error and is an indication of how much emphasis or weight will be placed on the current observation. If $P_{(k|k-1)}$ is small, the Kalman gain matrix will also be small due to the finite value of R_k . If the $P_{(k|k-1)}$ is relatively large, the gain is approximately one. By rewriting the equation for the calculation of the state estimate Equation (3.11), as

$$\hat{\mathbf{x}}_{(k|k)} = (I - G_k H_k) \hat{\mathbf{x}}_{(k|k-1)} + G_k \mathbf{z}_k \quad (3.13)$$

we can see how the Kalman gain matrix directly affects the weight placed on the current observation \mathbf{z}_k . A large gain, indicating a large a priori error covariance, will place more weight on the current observation as the filter tries to correct the states. A small gain, indicating a small error covariance, places less emphasis on the new observation.

If the Kalman gain is expressed as

$$G_k = P_{(k|k-1)} H_k^T R_k^{-1} \quad (3.14)$$

it can be seen that the gain matrix is "proportional" to the uncertainty in the estimate $P_{(k,k-1)}$ and "inversely proportional" to the measurement noise R_k . For a large R_k and a small $P_{(k,k-1)}$, the measurement in Equation (3.2) is due mainly to noise and only small corrections should be made in the state estimate. However, if R_k is small and $P_{(k,k-1)}$ is large, the measurement contains considerable information about the errors in the estimates and therefore, a strong correction should be made to the state estimates [Ref. 5: pp. 127-8].

The computation process for prediction is divided into the following steps: 1) calculate the estimate using Equation (3.11) and 2) use Equation (3.8) for the desired prediction.

The block diagram of the system with Kalman Filter is shown in Figure 4 and the system predictor block diagram is shown in Figure 5.

STATE ESTIMATION BLOCK DIAGRAM

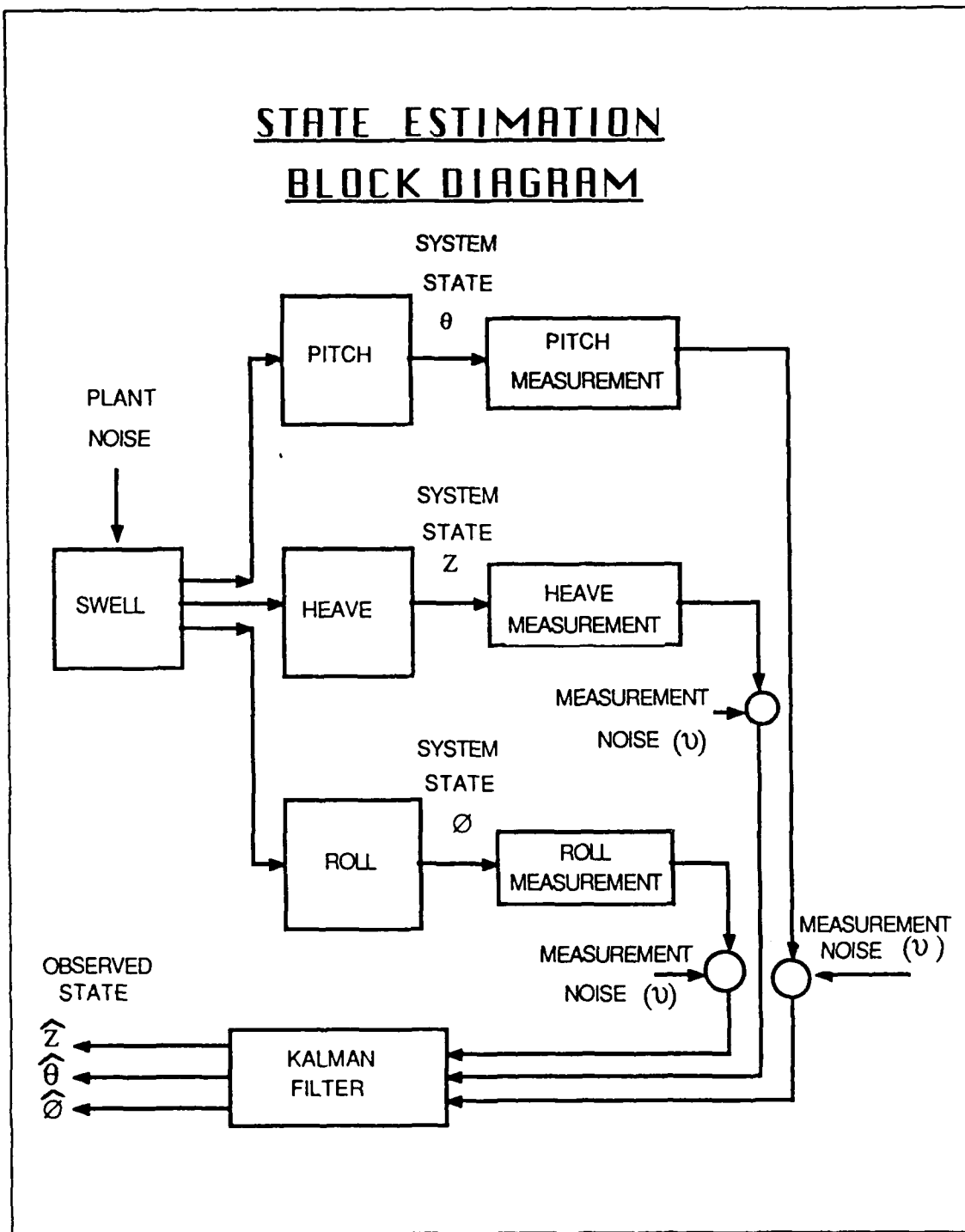

Figure 4. Ship Motion Model Diagram With Estimator

STATE PREDICTION BLOCK DIAGRAM

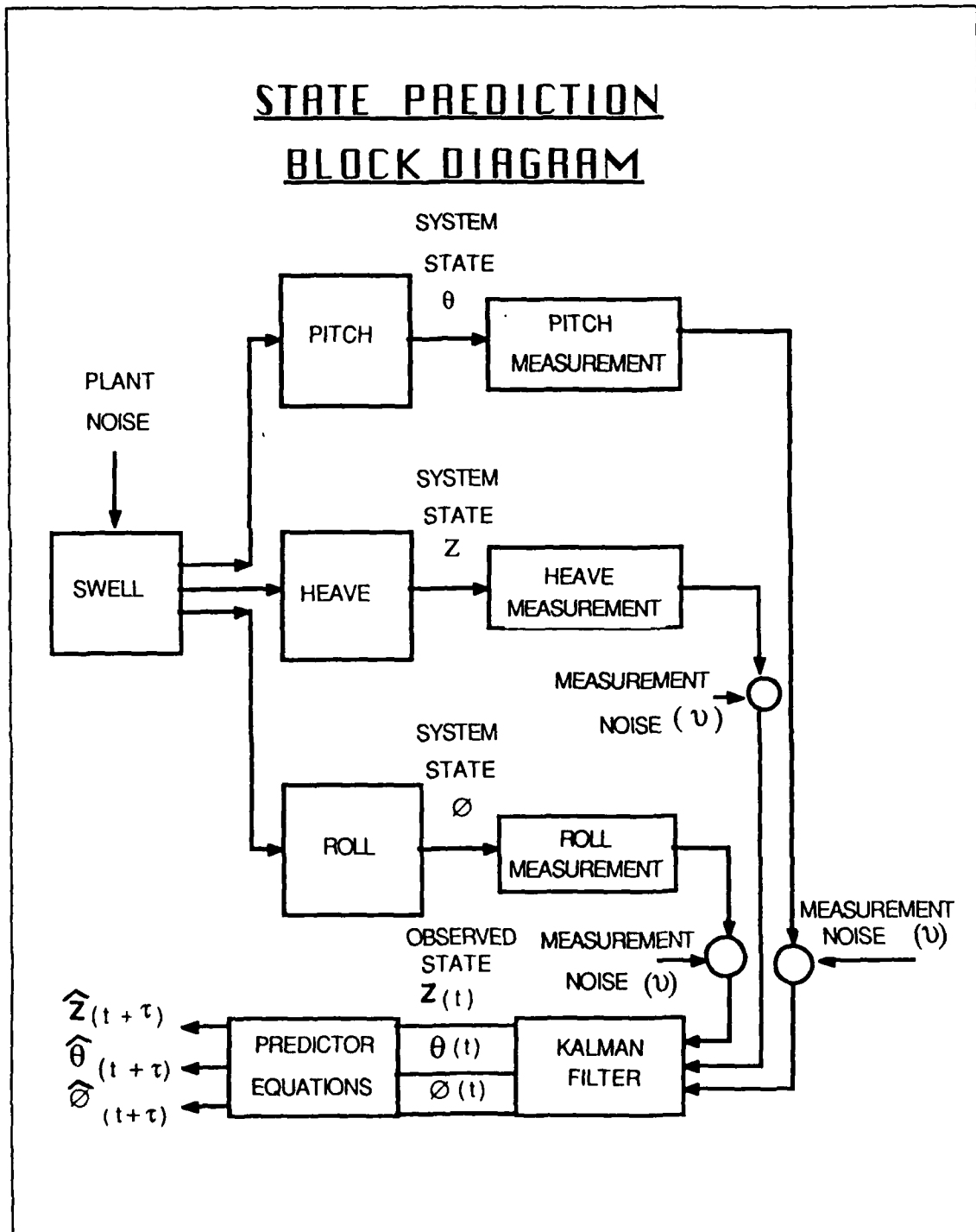

Figure 5. Ship's Motion Predictor Block Diagram

IV. COMPUTER SIMULATIONS

A. GENERAL

A measured simulated ship motion (heave, pitch and roll) and the forcing function data were chosen based from the ship speed of 25 knots, heading 000 degrees true and the swell wave heading direction at 120 degrees true. The sea state for a swell wave height of 11 feet is between 5 and 6 based on Bhattacharyya [Ref. 1: p. 104] which can be described that large waves begins to form while white crests are extensive everywhere (probably some spray). The wind force (beaufort) is classified as level 6 which is characterized by a strong breeze with the velocity of 25 knots.

These measured data were used in the Matlab computer program ([Ref. 7] and [Ref. 8]) algorithm (as shown in Appendix A) to generate the graphical results to see the physical representation of the ship motion oscillations. These graphical representations of swell, heave, pitch and roll, which are the results from the above computer runs, have the following parameters listed in Table 1 and are shown in Figures 6, 7, 8 and 9.

Table 1. WAVE AND SHIP MOTION PARAMETERS, TS = 0.1 SEC

Coefficient	Swell	Heave	Pitch	Roll
Wave ht (ft)	11	--	--	--
Period (sec)	7	11	10	18
ω (rad sec)	0.8976	0.5712	0.6283	0.3491
Damping	0	0.6854	0.7540	0.4189
Restoring	0	0.5712	0.6283	0.3491
Kalman Gain	--	0.1255 0.0841	0.1191 0.0756	0.2197 0.2721

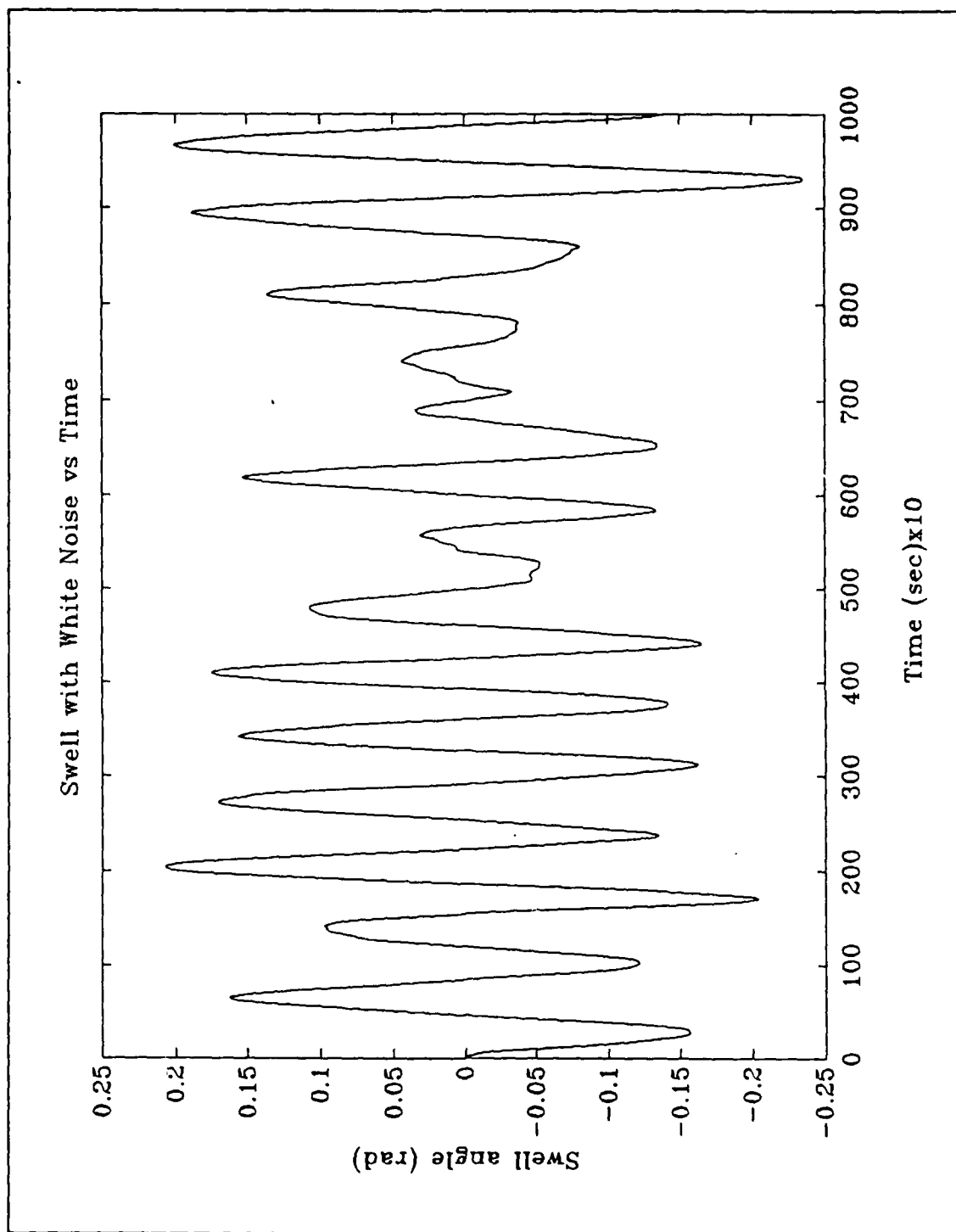

Figure 6. Swell Wave Motion with a Height of 11 feet

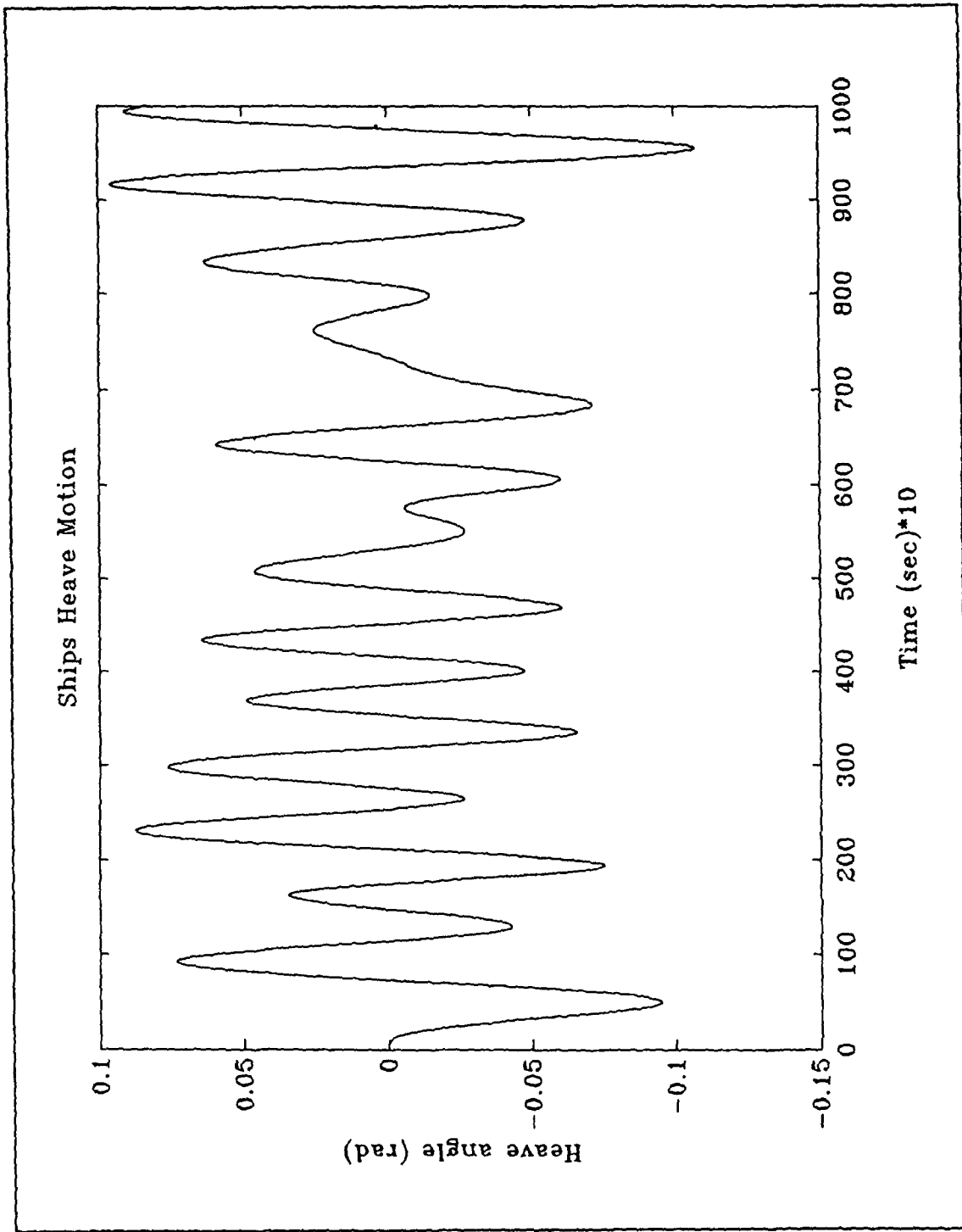

Figure 7. Ship's Heave Motion caused by 11 feet high of Swell

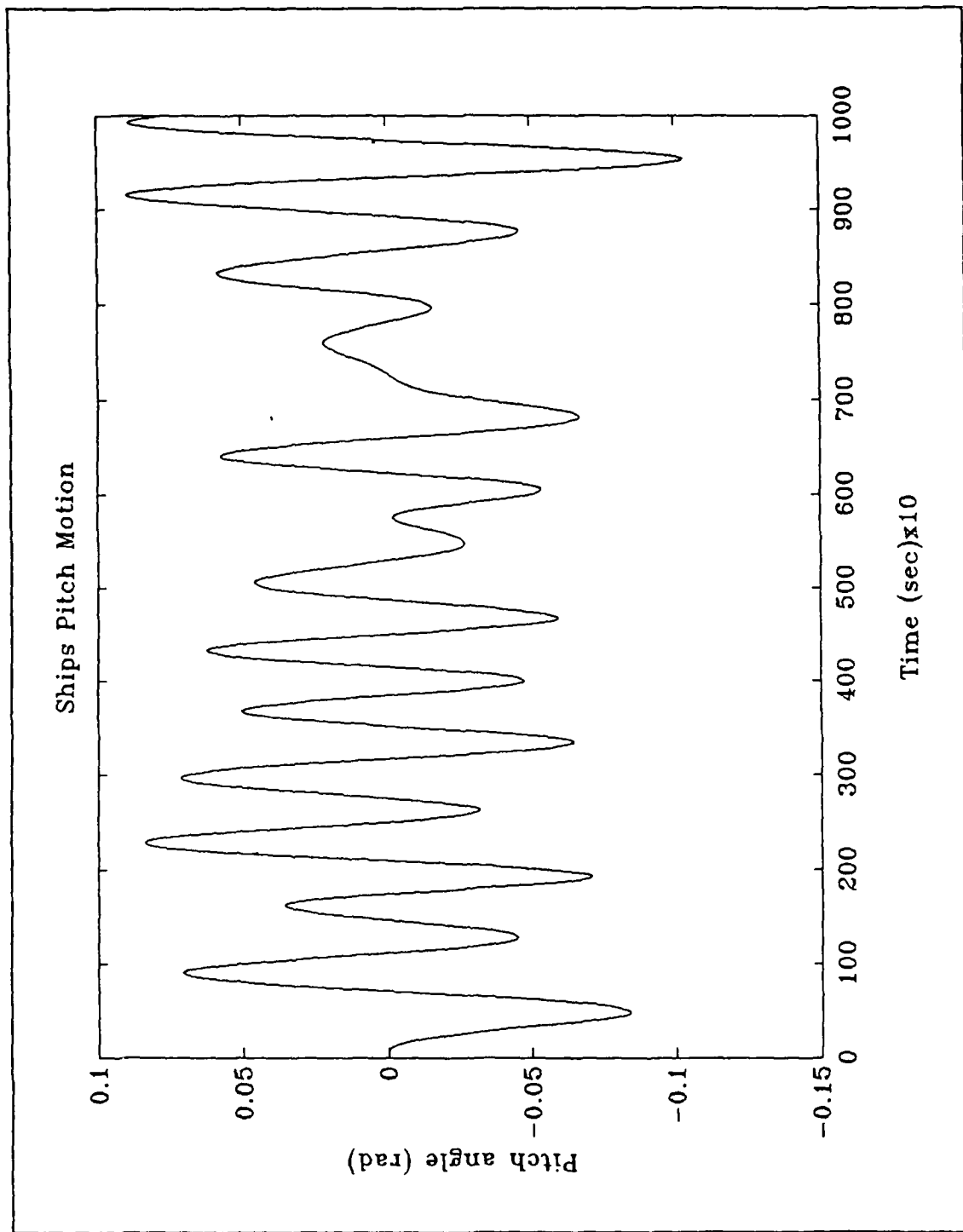

Figure 8. Ship's Pitch Motion caused by 11 feet high of Swell

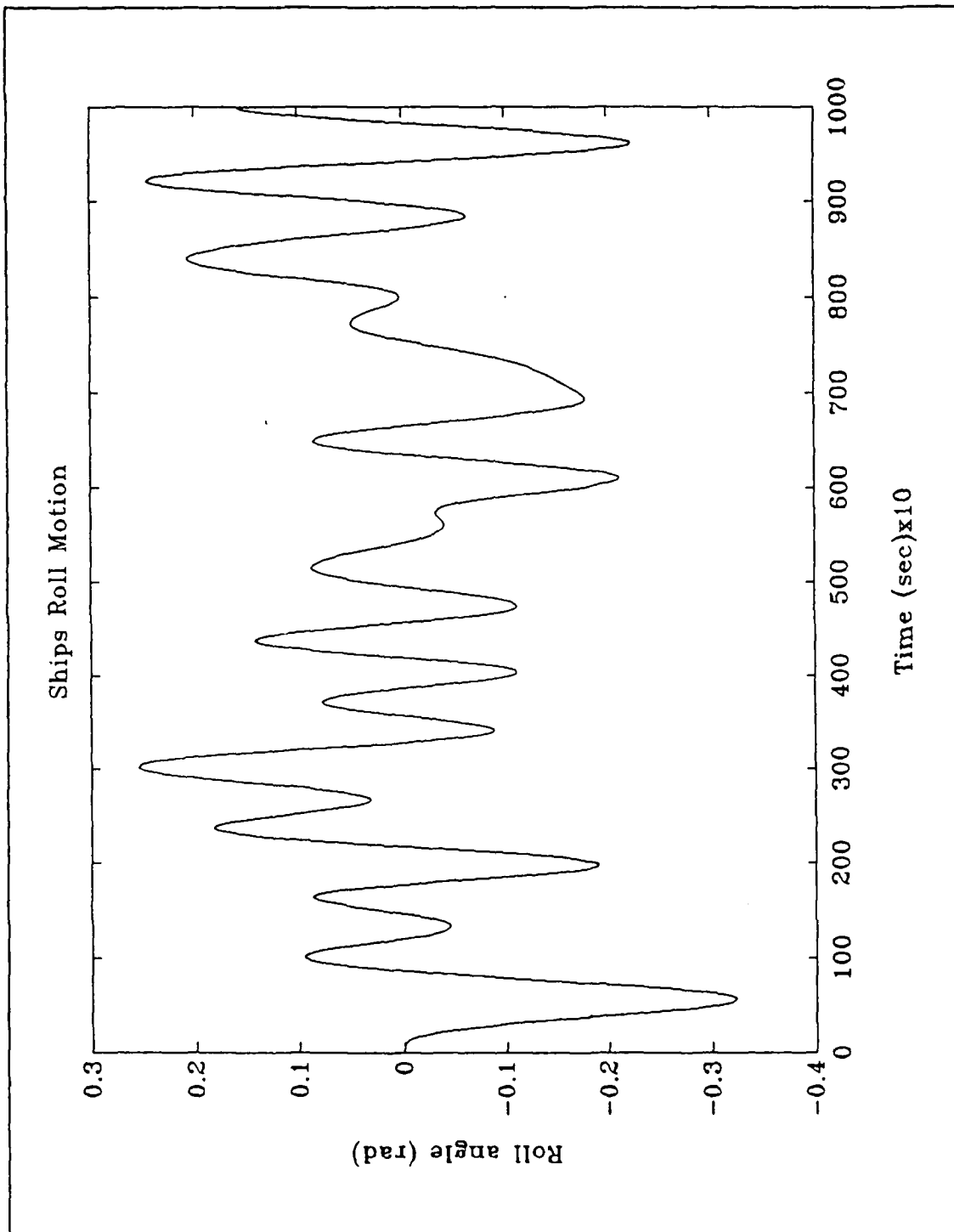

Figure 9. Ship's Roll Motion caused by 11 feet high of Swell

With the simulated observed ship motion data for heave, pitch and roll generated from the above computer runs, the Kalman filter was used to calculate the estimates by using the Matlab computer program algorithm generated as shown in Appendix B. The resulting estimated data were represented in graphical form to show the difference between the observed and the estimated ship motions. These graphs, with estimates, are shown in Figures 10, 11 and 12. Computer runs were also conducted to show the graphical representations of the predicted ship motions heave, pitch and roll. A Matlab computer program is shown in Appendix C for this calculation. These graphical predictions of ship motions are shown in Figures 13, 14 and 15. As we can see, the estimates and predictions illustrate a well-defined representation of the ship motion that can be used in the prediction of the ship motion in the future time which is to be relayed to the Landing Signal Officer for his decision for waveoffs and to the aircraft's pilot through the aircraft's TACAN during the recovery phase of flight operations.

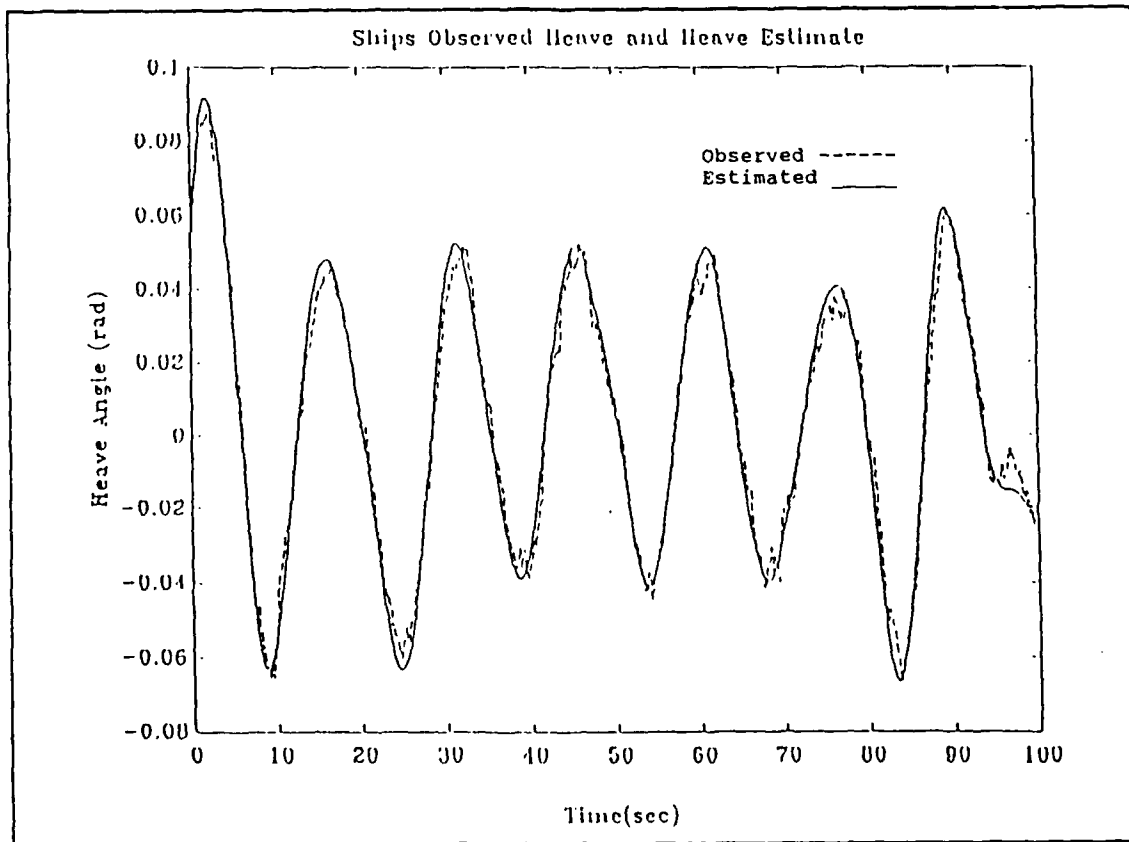

Figure 10. Observed and Estimated Heave Motion caused by 11 feet high of Swell

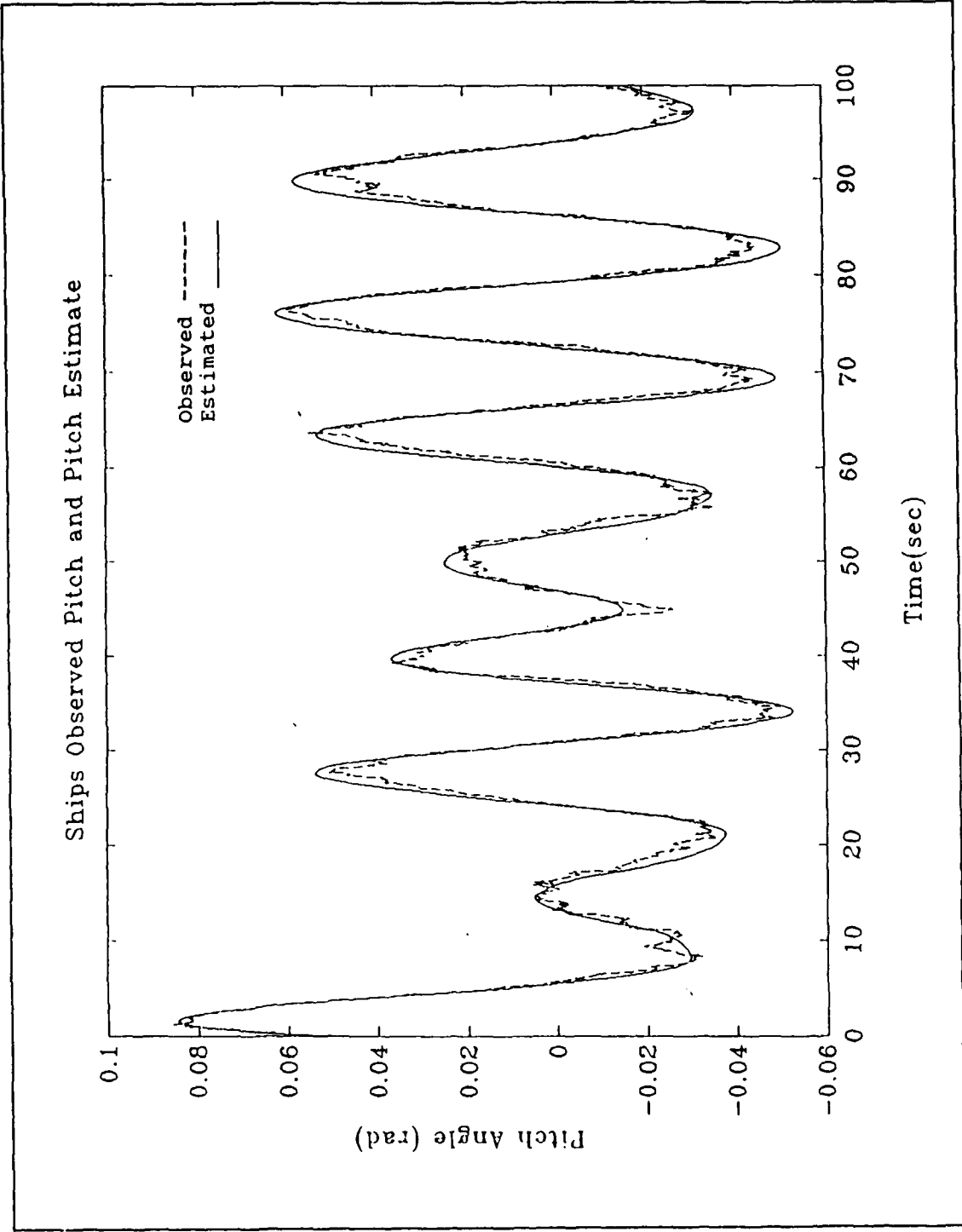

Figure 11. Observed and Estimated Pitch Motion caused by 11 feet high of Swell

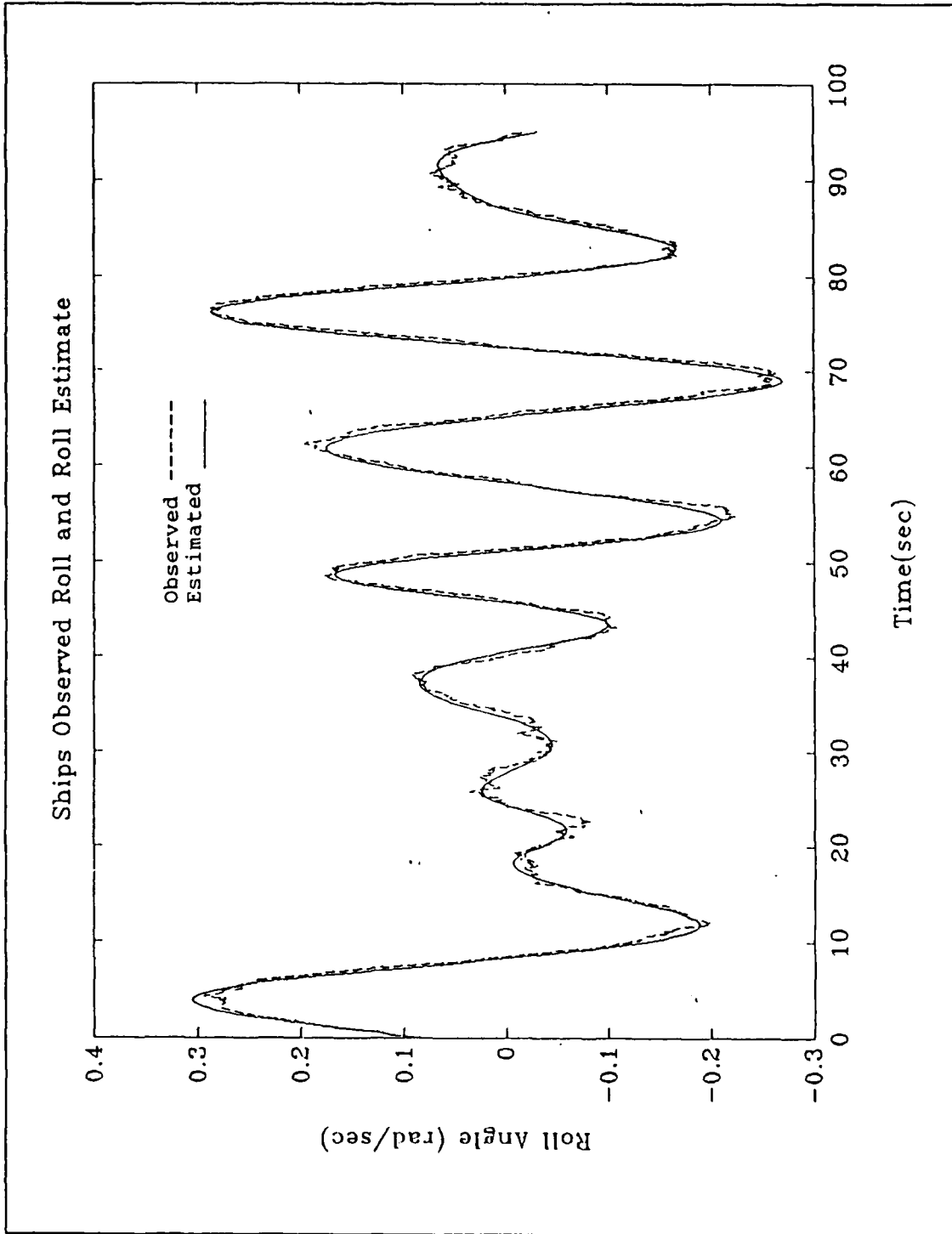

Figure 12. Observed and Estimated Roll Motion caused by 11 feet high of Swell

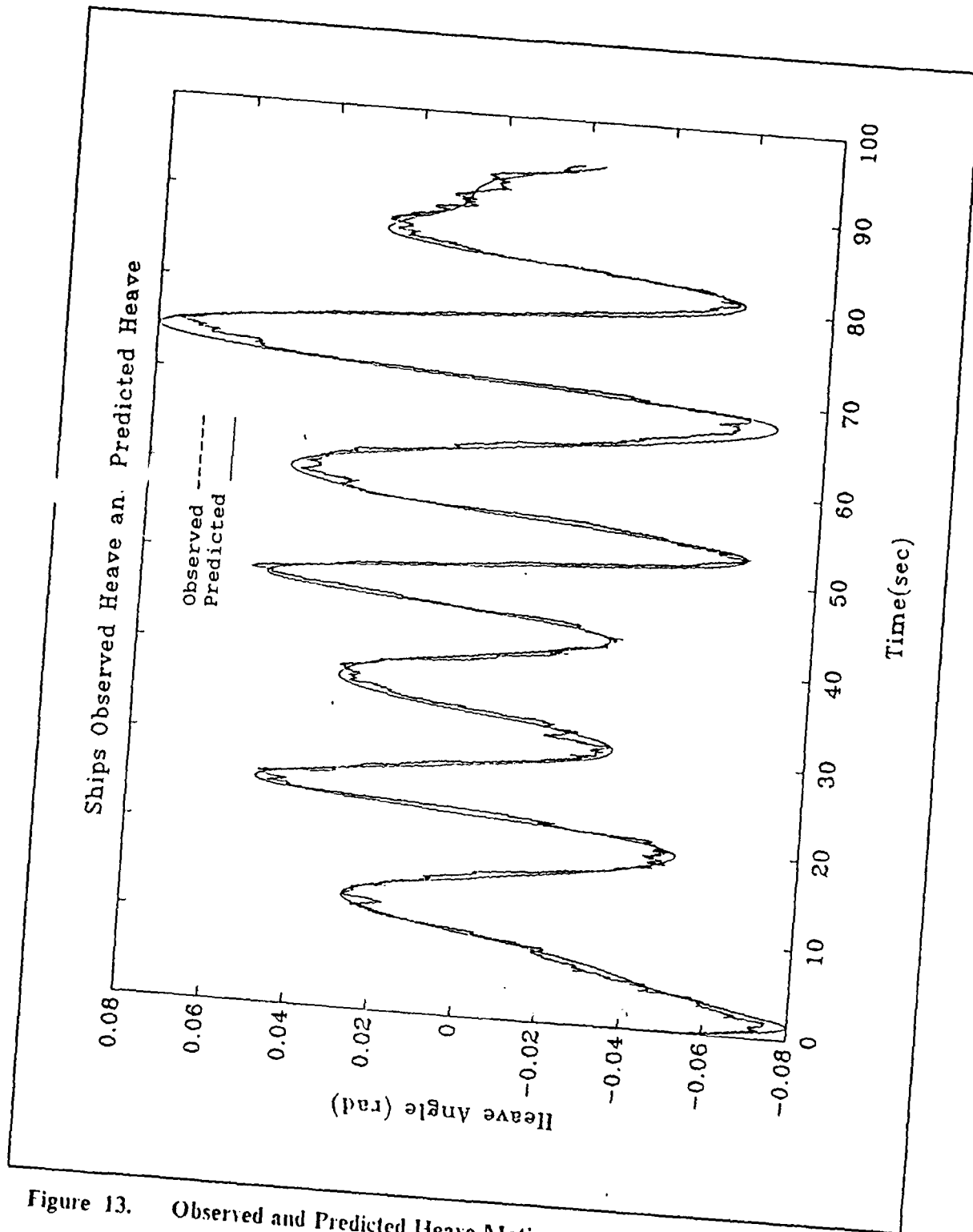

Figure 13. Observed and Predicted Heave Motion caused by 11 feet high of Swell

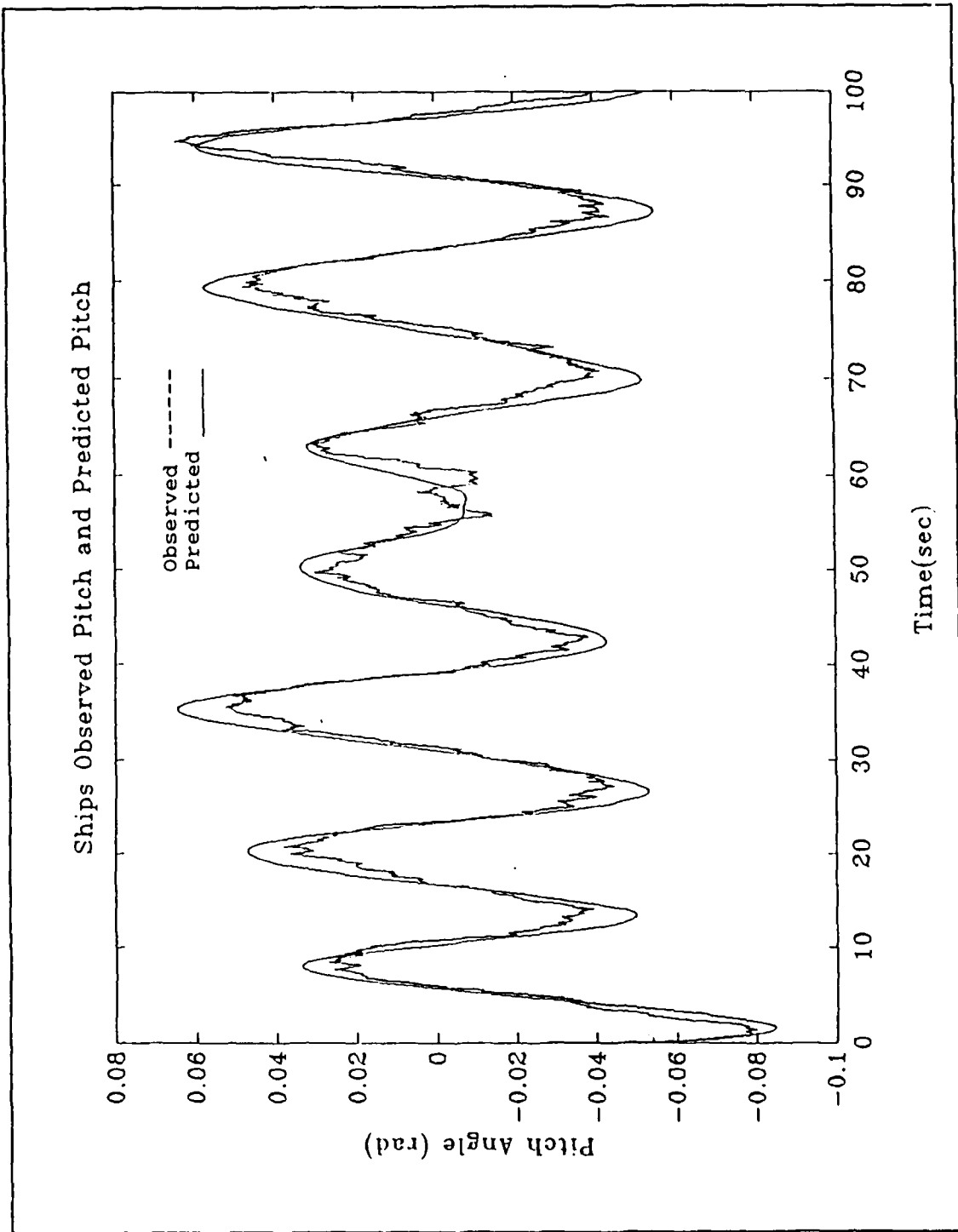

Figure 14. Observed and Predicted Pitch Motion caused by 11 feet high of Swell

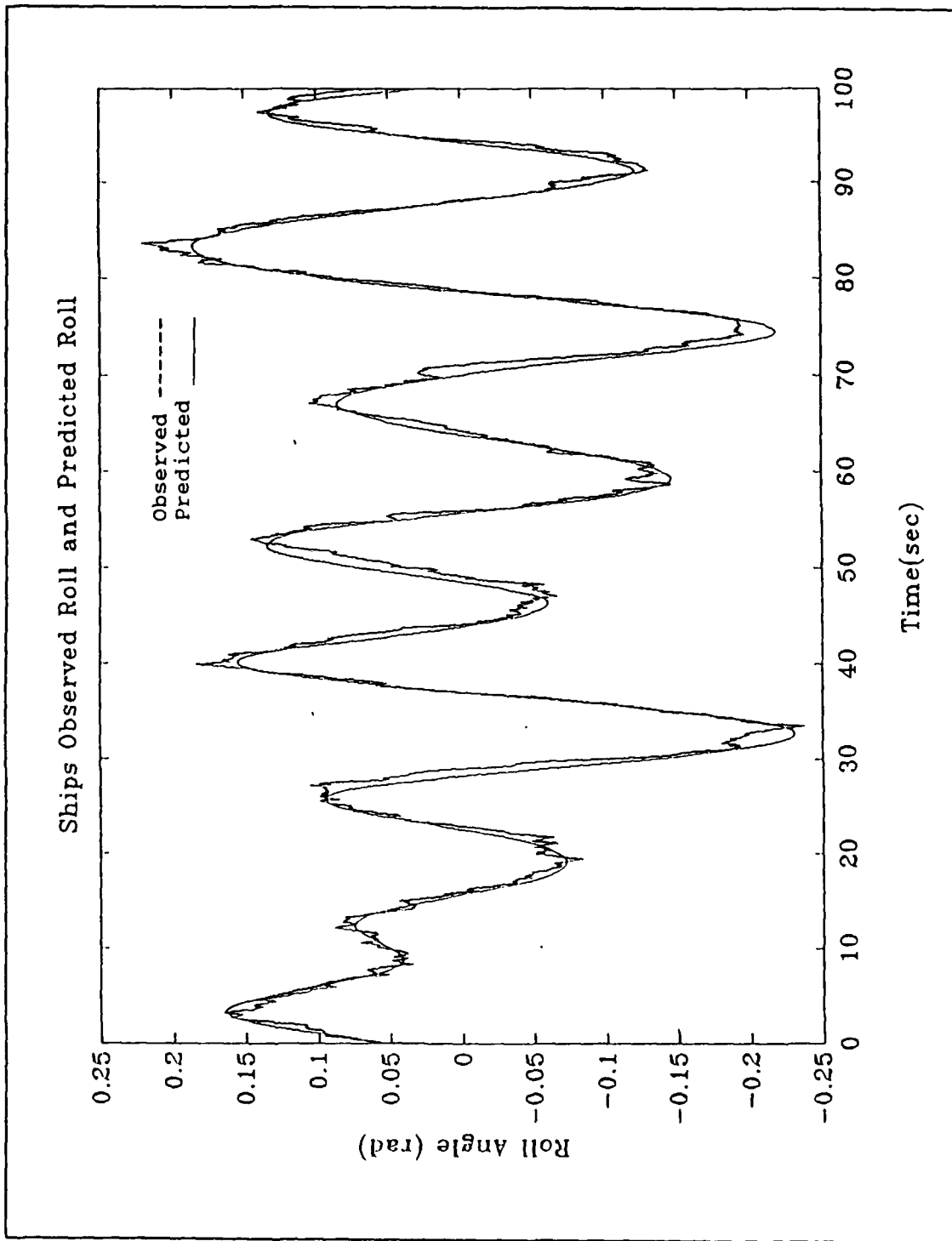

Figure 15. Observed and Predicted Roll Motion caused by 11 feet high of Swell

V. CONCLUSIONS

The feasibility of estimating an aircraft carrier motion at sea by measuring the ship's actual position and motion was investigated. The ship's motion representation was generated based on ship's motion mathematical model taken from [Ref. 1]. Subsequently, a Kalman filter-estimator adapted for real-time computation on a digital computer, was generated. The results obtained show that the desired prediction time can be reached with reasonably acceptable errors.

Being able to predict the ship's motion can lead to an improvement of aircraft landing accuracy and safety. This can be accomplished, for instance, by generating terminal guidance (landing) laws making use of the future ship's motion and position. Moreover, the possibility of prediction can improve the LSO information and policy for landing acceptance or wave-offs. The possibility of processing the measured motion by Fast Fourier Transform Algorithms (FFT), in order to obtain the estimated ship motion parameters such as the heave (z), pitch (θ) and roll (ϕ), in real time may lead toward an adaptive predictor scheme.

APPENDIX A. MATLAB PROGRAM 1

This Matlab computer program calculates the Observed Ship's Motion such as the heave, pitch and roll of the ship. Required coefficients must be available to run the program.

```

% A Matlab program to generate the ship's heave, pitch and roll
% roll motion with a given Swell wave force of N sin ws*t.
%
%
%%%%%%%%%%%%%%%%%%%%%%%%%%%%%%%%%%%%%%%%%%%%%%%%%%%%%%%%%%%%%%%%%%%%%%%%%% SWELL parameter %%%%%%%%%%%
%
%
diary p.m
% Swell period (Ts) seconds
    Ts=7;

% Swell angular frequency
    ws= 2*pi*1/Ts ;

% Wave Height (N) feet
    N=11;
    b1=N*ws;

% Restoring coefficient
    cs=ws**2 ;

%
%
%%%%%%%%%%%%%%%%%%%%%%%%%%%%%%%%%%%%%%%%%%%%%%%%%%%%%%%%%%%%%%%%%%%%%%%%%% Heave parameter %%%%%%%%%%%
%
% Heave period (th) seconds typical for carriers
    th= 11;

% Heave angular frequency (wh) rad/sec
    wh= 2*pi*1/th ;

%
% Heave restoring coefficient (cz)
    cz=wh

% Heave damping factor (zetah)
    zetah= 0.6;

% Damping coefficient (bh)
    bz=2*zetah*wh ;

%
%
%%%%%%%%%%%%%%%%%%%%%%%%%%%%%%%%%%%%%%%%%%%%%%%%%%%%%%%%%%%%%%%%%%%%%%%%%% Pitch parameter %%%%%%%%%%%
%

```

```

%
% Pitch period (tp) seconds typical for carriers
% tp=10;

% Pitch angular frequency (wp) rad/sec
% wp= 2*pi*1/tp ;

%
% Pitch Restoring coefficient
% cp=wp

% Heave damping factor (zetap) ;
% zetap= 0.6 ;

% Damping coefficient (bp) ;
% bp=2*zetap*wp ;

%
%
% Roll parameter
%
% Roll period (tr) seconds typical for carriers
% tr= 18;

% Roll angular frequency (wr) rad/sec
% wr= 2*pi*1/tr ;

% Roll Restoring coefficient
% cr=wr

% Roll damping factor (zetar) ;
% zetar= 0.6 ;

% Damping coefficient (br) ;
% br=2*zetar*wr ;

%
%
% Parameters of the system
%
% where:
% a=[]; -- the A matrix coefficient in continuous time
% b=[]; -- the B matrix coefficient in continuous time

%
% Swell Parameters
%
% as=-0 1; -cs 0-;
% bs=[ 0; 1];

%
% Heave Parameters
%

```



```

yp=dlsim(php, gamp, c, d, us);
yr=dlsim(phir, gamr, c, d, us);
%
%
%%%%%%%%%% Plot the generated output vs time of the system %%%%%%%%%%
%
plot(yh),title('Ships Heave Motion');
xlabel('Time (sec)'),ylabel('Heave angle (rad)');
delete pitch.met
meta pitch

plot(yp),title('Ships Pitch Motion');
xlabel('Time (sec)'),ylabel('Pitch angle (rad)');
meta
plot(yr),title('Ships Roll Motion');
xlabel('Time (sec)'),ylabel('Roll angle (rad)');
meta
plot(v),title('Random Noise vs Time');
xlabel('Time (sec)'),ylabel('Noise Magnitude');
meta
plot(us),title('Swell with White Noise vs Time');
xlabel('Time (sec)'),ylabel('Swell angle (rad)');
meta
%
```

APPENDIX B. MATLAB PROGRAM 2

This Matlab computer program calculates the Observed Ship's Motion and estimates in real time such as the heave, pitch and roll of the ship. Required coefficients must be available to run the program.

```

% This Matlab computer program calculates the Observed and Estimated
% state of the Ship's Heave, Pitch and Roll based on the given data.
%
%
%%%%%%%%%%%%%%%%%%%%%%%%%%%%%%%%%%%%%%%%%%%%%%%%%%%%%%%%%%%%%%%%%%%%%%%% SWELL parameter %%%%%%%%%%
%
%
diary p.m
% Swell period (Ts) seconds
      Ts=7 ;

% Swell angular frequency
      ws= 2*pi*1/Ts ;

% Wave Height (N) feet
      N=11;

% Restoring coefficient
      cs=ws**2 ;

%
%
%%%%%%%%%%%%%%%%%%%%%%%%%%%%%%%%%%%%%%%%%%%%%%%%%%%%%%%%%%%%%%%%%%%%%%%% Heave parameter %%%%%%%%%%
%
% Heave period (th) seconds typical for carriers
      th= 11 ;

% Heave angular frequency (wh) rad/sec
      wh= 2*pi*1/th ;

%
% Heave restoring coefficient (cz)
      cz=wh ;

% Heave damping factor (zetah)
      zetah= 0.6;

% Damping coefficient (bh)
      bz=2*zetah*wh ;

%
%
%%%%%%%%%%%%%%%%%%%%%%%%%%%%%%%%%%%%%%%%%%%%%%%%%%%%%%%%%%%%%%%%%%%%%%%% Pitch parameter %%%%%%%%%%
%
% Pitch period (tp) seconds typical for carriers

```

```

        tp=10;

% Pitch angular frequency (wp) rad/sec
        wp= 2*pi*1/tp ;

%
% Pitch Restoring coefficient
        cp=wp ;

% Heave damping factor (zetap)
        zetap= 0.6 ;

% Damping coefficient (bp)
        bp=2*zetap*wp ;

%
%
% Roll parameter
%
% Roll period (tr) seconds typical for carriers
        tr= 18;

% Roll angular frequency (wr) rad/sec
        wr= 2*pi*1/tr ;

% Roll Restoring coefficient
        cr=wr ;

% Roll damping factor (zetar)
        zetar= 0.6 ;

% Damping coefficient (br)
        br=2*zetar*wr ;

%
%
% Parameters of the system
%
where:
        a=[]; -- the A matrix coefficient in continuous time
        b=[]; -- the B matrix coefficient in continuous time

        Swell Parameters

        as=-0 1; -cs 0-;
        fs=[ 0; 1];

        Heave Parameters

        ah=[ 0 1; -cz**2 -bz] ;
        fh=[ 0; .3];

```

```

%
%      Pitch Parameters
%
ap=[ 0 1; -cp**2 -bp] ;
fp=[ 0; .3];

%
%      Roll Parameters
%
ar=[ 0 1; -cr**2 -br] ;
fr=[ 0; .6];
diary off

%
%      Measurement Parameters
%
c=[ 1 0];
dt=0.1;

%
%      Swell Noise
%      -----
q=1/100;

%
%      Measurement Noise
%      -----
r=1/8500;

d=[ 0];

%
%
%
% Determine the Discrete coefficient of the system %
%
%      Swell
%      -----
[phis,gams]=c2d(as,fs,dt) ;

%
%      HEAVE
%      -----
[phih,gamh]=c2d(ah,fh,dt) ;

%
%      PITCH
%      -----
[phip,gamp]=c2d(ap,fp,dt) ;

%
%      ROLL
%      -----
[phir,gamr]=c2d(ar,fr,dt) ;

```

```

%
% Calculate the Kalman Gains for Heave, Pitch and Roll %
%
kh=dlqe(phih,gamh,c,q,r) ;
kp=dlqe(phip,gamp,c,q,r) ;
kr=dlqe(phir,gamr,c,q,r) ;
%
% Initial Condition %
%
xh=[ 0.05;0.05] ;
xhe=[ 0.05;0.05] ;
xp=[ 0.05;0.05] ;
xpe=[ 0.05;0.05] ;
xr=[ 0.050;0.0506] ;
xre=[ 0.05;0.05] ;
xs=[ 0.05;0.05] ;
%
% Random Noise Generators %
%
rand('normal')
w=sqrt(q)*rand(1,1500);
v=sqrt(r)*rand(1,1500);
t=0:.1:100;
%
% Simulation Loop %
%
for k=1:1000;
%
% Input for Heave, Pitch nad Roll %
xs(:,k+1)=phis*xs(:,k) + gams*w(k);
%
% State calculation for Heave, Pitch and Roll %
%
xh(:,k+1)=phih*xh(:,k) + gamh*xs(k) ;
xp(:,k+1)=phip*xp(:,k) + gamp*xs(k) ;
xr(:,k+1)=phir*xr(:,k) + gamr*xs(k) ;
%
%
% Output calculation for Heave, Pitch and Roll in Discrete form
%
yh(:,k+1)=c*xh(:,k+1) + v(k+1);
yp(:,k+1)=c*xp(:,k+1) + v(k+1);
yr(:,k+1)=c*xr(:,k+1) + v(k+1);
%
%
% State estimate calculation for Heave, Pitch and Roll %
%
xhe(:,k+1)= phih*xhe(:,k) + kh*(yh(:,k+1)-c*(phih*...
xhe(:,k) ));
xpe(:,k+1)= phip*xpe(:,k) + kp*(yp(:,k+1)-c*(phip*...
xpe(:,k) ));
xre(:,k+1)= phir*xre(:,k) + kr*(yr(:,k+1)-c*(phir*...
xre(:,k) ));

```

```
end
%
%
plot(t,xh(1,:),t,xhe(1:)),title('Ships
Observed Heave and Heave Estimate')
  xlabel('Time(sec)'),ylabel('Heave Angle (rad)')
  delete esth.met
  meta est

plot(t,xp(1,:),t,xpe(1:)),title('Ships
Observed Pitch and Pitch Estimate')
  xlabel('Time(sec)'),ylabel('Pitch Angle (rad)')
  meta

plot(t,xr(1,:),t,xre(1:)),title('Ships
Observed Roll and Roll Estimate')
  xlabel('Time(sec)'),ylabel('Roll Angle (rad)')
  meta

%
```



```

        tp=10;

% Pitch angular frequency (wp) rad/sec
        wp= 2*pi*1/tp ;

%
%
% Pitch Restoring coefficient
        cp=wp ;

%
% Heave damping factor (zetap)
        zetap= 0.6 ;

%
% Damping coefficient (bp)
        bp=2*zetap*wp ;

%
%
% Roll parameter
% Roll period (tr) seconds typical for carriers
        tr= 18;

% Roll angular frequency (wr) rad/sec
        wr= 2*pi*1/tr ;

% Roll Restoring coefficient
        cr=wr ;

% Roll damping factor (zetar)
        zetar= 0.6 ;

% Damping coefficient (br)
        br=2*zetar*wr ;

%
%
% Parameters of the system
%
% where:
% a=[]; -- the A matrix coefficient in continuous time
% b=[]; -- the B matrix coefficient in continuous time
%
% Swell Parameters
%
% as=[ 0 1; -cs 0];
% fs=[ 0; 1];
%
% Heave Parameters
%
% ah=[ 0 1; -cz**2 -bz] ;
% fh=[ 0; . 3];

```



```

%
%% Calculate the Kalman Gains for Heave, Pitch and Roll %%
%
kh=dlqe(phih,gamh,c,q,r) ;
kp=dlqe(hip,gamp,c,q,r) ;
kr=dlqe(phir,gamr,c,q,r) ;
%
%% Initial Condition %%
%
xh=[ -0.05; -0.05] ;
xhe=[ -0.05; -0.05] ;
xp=[ 0.05; -0.05] ;
xpe=[ -0.05; -0.05] ;
xr=[ 0.050; -0.050] ;
xre=[ -0.05; -0.05] ;
xs=[ 0.05; -0.05] ; ;
%
%% Random Noise Generators %%
%
rand('normal')
w=sqrt(q)*rand(1,1200);
v=sqrt(r)*rand(1,1200);
t=0:.1:95;
%
%% Simulation Loop %%
%
for k=1:950;
%
%% Input for Heave, Pitch nad Roll %%
%
xs(:,k+1)=phis*xs(:,k) + gams*w(k);
%
%% State calculation for Heave, Pitch and Roll %%
%
xh(:,k+1)=phih*xh(:,k) + gamh*xs(k) ;
xp(:,k+1)=hip*xp(:,k) + gamp*xs(k) ;
xr(:,k+1)=phir*xr(:,k) + gamr*xs(k) ;
%
%% Output calculation for Heave, Pitch and Roll in Discrete form
%
yh(:,k+1)=c*xh(:,k+1) + v(k+1);
yp(:,k+1)=c*xp(:,k+1) + v(k+1);
yr(:,k+1)=c*xr(:,k+1) + v(k+1);
%
%% State estimate calculation for Heave, Pitch and Roll %%
%
xhe(:,k+1)= phih*xhe(:,k) + kh*(yh(:,k+1)-c*(phih*...
xhe(:,k) ));
xpe(:,k+1)= phip*xpe(:,k) + kp*(yp(:,k+1)-c*(phip*...
xpe(:,k) ));
xre(:,k+1)= phir*xre(:,k) + kr*(yr(:,k+1)-c*(phir*...
xre(:,k) ));
%
%

```

```

%
%
% State Prediction Calculation for Heave, Pitch and Roll %
%
xhp(:,k+1)=phih*xhe(:,k) + gamh*xs(k) ;
xpp(:,k+1)=phip*xpe(:,k) + gamp*xs(k) ;
xrp(:,k+1)=phir*xre(:,k) + gamr*xs(k) ;
end
%
%
plot(t,xh(1:,:),'- ',t,xhp(1:)),title('Ships
Observed Heave and Predicted Heave')
xlabel('Time(sec)'),ylabel('Heave Angle (rad)')
delete predicth.met
meta predicth

plot(t,xp(1:,:),'- ',t,xpp(1:)),title('Ships
Observed Pitch and Predicted Pitch')
xlabel('Time(sec)'),ylabel('Pitch Angle (rad)')
meta

plot(t,xr(1:,:),'- ',t,xrp(1:)),title('Ships
Observed Roll and Predicted Roll')
xlabel('Time(sec)'),ylabel('Roll Angle (rad)')
meta

```

LIST OF REFERENCES

1. Bhattacharyya, R., *Dynamics Of Marine Vehicles*, Naval Academy, John Wiley & Sons, New York, 1978.
2. Wah, Thein, *A Guide For The Analysis of Ship Structures*, U. S. Department Of Commerce, Office of Technical Services, Washington 25, D. C., 1960.
3. Korvin-Kroukovsky, B.V., *Theory Of Seakeeping*, The Society Of Naval Architects and Marine Engineers, New York, 1961.
4. Blagoveshchensky, S.N., *Theory Of Ship Motions*, Dover Publications, Inc., New York, 1962.
5. Gelb, Arthur, *Applied Optimal Estimation*, M.I.T. Press, Cambridge, Massachusetts, 1974.
6. Kirk, Donald, E., *Optimal Estimation: Introduction to the Theory and Application*, Naval Postgraduate School, Monterey, California, 1975.
7. Cleve, M., Little, J., and Bangert, S., *PC-MATLAB for MS-DOS Personal Computer*, The MathWorks, Inc., 1986.
8. Coschi, G., Schueler, J.B., *WATFOR-77 Language Reference Manual*, WATCOM Publications Limited, December 1984.

INITIAL DISTRIBUTION LIST

	No. Copies
1. Defense Technical Information Center Cameron Station Alexandria, VA 22304-6145	2
2. Library, Code 0142 Naval Postgraduate School Monterey, CA 93943-5002	2
3. Chairman, Code 62 Department of Electrical and Computer Engineering Naval Postgraduate School Monterey, CA 93943-5002	1
4. Professor Hal A. Titus, Code 62Ts Department of Electrical Engineering Naval Postgraduate School Monterey, CA 93943-5002	5
5. Professor Jeffery Burl, Code 62B1 Department of Electrical Engineering Naval Postgraduate School Monterey, CA 93943-5002	2
6. Commander Naval Ocean Systems Center San Diego, CA 92152-5000	1
7. LT Jose F. Garcia III 1509 Magnolia Street Oakland, CA 96407	2