

AD-A216 863

2

IDA PAPER P-2227

THE USE OF TECHNOLOGY TRANSFER CENTERS BY
DEPARTMENT OF DEFENSE INDUSTRIAL FACILITIES

DTIC
ELECTE
JAN 25 1990
S D
D CS

Paul H. Richanbach
Frederick R. Riddell

October 1989

DISTRIBUTION STATEMENT A
Approved for public release
Distribution Unlimited

Prepared for
Office of the Under Secretary of Defense for Acquisition
(Research and Advanced Technology)

Supported by
Naval Supply Systems Command



INSTITUTE FOR DEFENSE ANALYSES
1801 N. Beauregard Street, Alexandria, Virginia 22311-1772

90 01 25 0 10

DEFINITIONS

IDA publishes the following documents to report the results of its work.

Reports

Reports are the most authoritative and most carefully considered products IDA publishes. They normally embody results of major projects which (a) have a direct bearing on decisions affecting major programs, (b) address issues of significant concern to the Executive Branch, the Congress and/or the public, or (c) address issues that have significant economic implications. IDA Reports are reviewed by outside panels of experts to ensure their high quality and relevance to the problems studied, and they are released by the President of IDA.

Group Reports

Group Reports record the findings and results of IDA established working groups and panels composed of senior individuals addressing major issues which otherwise would be the subject of an IDA Report. IDA Group Reports are reviewed by the senior individuals responsible for the project and others as selected by IDA to ensure their high quality and relevance to the problems studied, and are released by the President of IDA.

Papers

Papers, also authoritative and carefully considered products of IDA, address studies that are narrower in scope than those covered in Reports. IDA Papers are reviewed to ensure that they meet the high standards expected of refereed papers in professional journals or formal Agency reports.

Documents

IDA Documents are used for the convenience of the sponsors or the analysts (a) to record substantive work done in quick reaction studies, (b) to record the proceedings of conferences and meetings, (c) to make available preliminary and tentative results of analyses, (d) to record data developed in the course of an investigation, or (e) to forward information that is essentially unanalyzed and unevaluated. The review of IDA Documents is suited to their content and intended use.

The work reported in this document was conducted under contract MDA 903 89 C 0003 for the Department of Defense. The publication of this IDA Paper does not indicate endorsement by the Department of Defense, nor should the contents be construed as reflecting the official position of that Agency.

This Paper has been reviewed by IDA to assure that it meets high standards of thoroughness, objectivity, and appropriate analytical methodology and that the results, conclusions and recommendations are properly supported by the material presented.

Approved for public release; distribution unlimited.

REPORT DOCUMENTATION PAGE

Form Approved
OMB No. 0704-0188

Public reporting burden for this collection of information is estimated to average 1 hour per response, including the time for reviewing instructions, searching existing data sources, gathering and maintaining the data needed, and completing and reviewing the collection of information. Send comments regarding this burden estimate or any other aspect of this collection of information, including suggestions for reducing this burden, to Washington Headquarters Services, Directorate for Information Operations and Reports, 1215 Jefferson Davis Highway, Suite 1204, Arlington, VA 22202-4302, and to the Office of Management and Budget, Paperwork Reduction Project (0704-0188), Washington, DC 20503.

1. AGENCY USE ONLY (Leave blank)		2. REPORT DATE October 1989		3. REPORT TYPE AND DATES COVERED Final Jan. 1989 to Apr. 1989	
4. TITLE AND SUBTITLE THE USE OF TECHNOLOGY TRANSFER CENTERS BY DEPARTMENT OF DEFENSE INDUSTRIAL FACILITIES			5. FUNDING NUMBERS C - MDA 903 89 C 0003 TA - T-D6-302		
6. AUTHOR(S) Frederick R. Riddell, Paul H. Richanbach			8. PERFORMING ORGANIZATION REPORT NUMBER IDA Paper P-2227		
7. PERFORMING ORGANIZATION NAME(S) AND ADDRESS(ES) Institute for Defense Analyses 1801 N. Beauregard Street Alexandria, VA 22311			10. SPONSORING/MONITORING AGENCY REPORT NUMBER		
9. SPONSORING/MONITORING AGENCY NAME(S) AND ADDRESS(ES) OUSD(A), R&AT Rm. 3D1089, Pentagon Washington, DC 20301-3080			11. SUPPLEMENTARY NOTES		
12a. DISTRIBUTION/AVAILABILITY STATEMENT Approved for public release; distribution unlimited.			12b. DISTRIBUTION CODE		
13. ABSTRACT (Maximum 200 words) One problem posed by the Navy's industrial facilities is that they do not have the resources to stay fully abreast of all of the new technologies or industrial processes of potential value to their facilities. This paper describes the attributes of various types of technology transfer centers in existence in the United States today, and provides a brief evaluation of which type of technology transfer capability is most appropriate to the needs of the Navy's shipyards and aviation depots. The paper recommends that the Navy provide its industrial activities with access to technology transfer centers, and suggests a five-step plan for accomplishing this.					
14. SUBJECT TERMS Technology Transfer, Navy Industrial Activities, Research and Development, Technology Transfer Centers				15. NUMBER OF PAGES 30	
				16. PRICE CODE	
17. SECURITY CLASSIFICATION OF REPORT UNCLASSIFIED	18. SECURITY CLASSIFICATION OF THIS PAGE UNCLASSIFIED	19. SECURITY CLASSIFICATION OF ABSTRACT UNCLASSIFIED	20. LIMITATION OF ABSTRACT UL		

IDA PAPER P-2227

THE USE OF TECHNOLOGY TRANSFER CENTERS BY DEPARTMENT OF DEFENSE INDUSTRIAL FACILITIES

Paul H. Richanbach
Frederick R. Riddell

October 1989

Accession For	
NTIS GRA&I	<input checked="" type="checkbox"/>
DTIC TAB	<input type="checkbox"/>
Unannounced	<input type="checkbox"/>
Justification	
By _____	
Distribution/	
Availability Codes	
Dist	A
A-1	



INSTITUTE FOR DEFENSE ANALYSES

Contract MDA 903 89 C 0003
Task T-D6-302

PREFACE

This paper is the result of work performed by the Institute for Defense Analyses (IDA) under contract number MDA 903 89 C 0003, task order T-D6-302, "Weapon Systems Support Technology." This work was performed for the Under Secretary of Defense for Acquisition (USD(A)). It is part of a continuing study by IDA of the potential impact of new technology on support costs. The question investigated here is the role that technology transfer centers might play in speeding the adoption of new technology and techniques at Navy industrial facilities.

This paper concludes by recommending a particular approach towards the establishment of technology transfer centers in the Navy. As one of the reviewers of this paper has noted, however, there are other alternative approaches that the Navy might wish to consider. Limitations on the scope of this project and the resources available prevented a thorough assessment of all such alternatives. One such alternative, as presented by the above-mentioned reviewer, is noted in the appendix, "Alternative Technology Transfer Center Approaches."

This paper was reviewed by Dr. Paul A. McWilliams of the University of Pittsburgh and by Mr. Howard P. Gates, Jr., a consultant to IDA.

CONTENTS

PREFACE	iii
A. Types and Attributes of Technology Transfer Centers	1
1. Introduction	1
2. Existing Technology Transfer Organizations.....	2
3. Types of Technology Transfer.....	5
4. Activities of a Technology Transfer Organization	7
5. Summary	8
B. The University of Michigan Project and Report.....	9
1. Introduction	9
2. Types of Technology Transfer.....	10
3. The Activities of a Technology Transfer Center	11
4. Summary	12
C. Recommendations.....	13
1. Field Activity Requirements.....	14
2. Systems Command Priorities	14
3. Navy Priorities.....	15
4. Technology Transfer Center Analysis.....	15
5. Funded Research	16
6. Initiating the Plan	16
DISTRIBUTION LIST	DL-1

Appendix

A. ALTERNATIVE TECHNOLOGY TRANSFER CENTER APPROACHES

THE USE OF TECHNOLOGY TRANSFER CENTERS BY DEPARTMENT OF DEFENSE INDUSTRIAL FACILITIES

The Institute for Defense Analyses (IDA) was asked by the Navy to evaluate the use of technology transfer centers as a method of helping Navy maintenance and repair facilities make use of the latest technology to carry out their functions in the most cost-effective manner possible. This paper provides the results of that evaluation. Section A discusses the different types of technology transfer centers that are found in the United States today and describes the essential attributes associated with each type. Section B provides an assessment of the draft report submitted to the Navy by the University of Michigan on its three-year technology transfer demonstration project. Section C provides a recommended implementation plan for the establishment of technology transfer centers in the Navy.

A. TYPES AND ATTRIBUTES OF TECHNOLOGY TRANSFER CENTERS

1. Introduction

A problem affecting the Navy's industrial facilities, one faced by many other public and private industrial operations, is that they do not have the resources (either the money or the people) to stay fully abreast of all of the new technologies or industrial processes of potential value to their facilities. Even when they are aware of potential opportunities, a lack of resources often hinders them from exploring or determining how those technologies or processes might be applied to their particular circumstances. The rapid pace of technological progress has made the identification and acquisition of advanced technology a major concern to enterprises throughout the US economy.

Within the Navy, and within the Department of Defense (DoD) generally, numerous mechanisms are already available for transferring technology and know-how from one individual or organization to another. The Navy shipyards, for example, sponsor annual meetings of their shop heads; the Joint Technology Exchange Group (JTEG) sponsors a

number of meetings at which ideas can be exchanged among the military services; the Manufacturing Technology Program funds the development of solutions to a wide range of technological and manufacturing problems; the Productivity Improvement Fund (PIF) provides monies for certain types of capital investments that promise high rates of return; and many newsletters and other publications that attempt to spread the word about successful technology applications or process improvements to the military services, the government, and the private sector, and many other examples exist.

In spite of these efforts, however, there is near universal agreement that more must be done to improve the process of technology transfer at government-operated industrial facilities. Before discussing the specific mechanisms by which technology transfer might be enhanced in the Navy, it is useful to first consider the different types of technology transfer organizations that already exist, the different types of technology transfer that can take place, and which of these types of technology transfer are of greatest relevance to the Navy's industrial facilities.

2. Existing Technology Transfer Organizations

There are two broad classes of organizations that engage in technology transfer--those that engage in R&D, and those that do not. This distinction is important because organizations that perform R&D typically have a very different approach to technology transfer than those that do not.

a. Technology Transfer with R&D

Within organizations that conduct R&D, there are two broad classes of R&D activities. First, there are the research consortia, or other cooperative research efforts, which involve collections of industry, university, and government researchers who work with and learn from one another. The research in this case typically involves basic rather than applied research, and immediate (short-term) technology transfer may be a small part of such an organization's efforts.

Among the organizations that concentrate on basic research and technology are the Science and Technology (S&T) Research Centers, which have been established through the National Science Foundation (NSF) at numerous universities around the country. The S&T Research Centers are large, multi-disciplinary centers geared primarily towards basic.

rather than applied, research. NSF encourages each center to develop links to potential users and others outside the center, and the majority of the centers have ties with industry.

Another example is the Engineering Research Centers, which are also being established by NSF at universities throughout the country. Each one will focus on a specific technical area, and will have a strong educational mission (training young engineers). The centers will conduct cooperative research with various industry partners, which is the mechanism by which most technology transfer takes place.

In addition to these two examples, a large number of universities have cooperative R&D arrangements with industry organizations, including, but not limited to, firms in the pharmaceuticals and microelectronics industries.

The second type of technology transfer effort in which R&D takes place involves applied technology. These efforts typically involve research that has as its goal the transfer of knowledge to engineers or managers at industrial facilities responsible for product design or investments in plant and equipment, rather than fellow researchers at industrial organizations. Prominent examples of efforts designed to promote the R&D and transfer of applied technology include SEMATECH, a cooperative research effort undertaken by the semiconductor industry with support from DoD; the National Center for Manufacturing Sciences, a cooperative research effort undertaken by the machine tool industry, also with support from DoD; and the RAMP (Rapid Acquisition of Manufactured Parts) Program, sponsored by the Navy with support from the National Institute of Standards and Technology (NIST), which is designed to demonstrate the advantages of advanced manufacturing methods in meeting Navy needs for small lot machined parts.

b. Technology Transfer Without R&D

Most technology transfer takes place without the conduct of R&D by either the providers or the recipients of the technology. A simple example of this type of technology transfer is a newsletter that informs subscribers of technological developments thought to be of potential interest to them. Numerous such newsletters are published by the Navy, the other military services, NASA, the Federal Lab Consortium, and many other government and private sector organizations.

Technology transfer without R&D also takes place through a large number of organizations established to provide advice and information on technology to business and government clients. In addition to the large number of for-profit organizations that fall into

this category--consultants, engineering firms, vendors, manufacturers, etc.--many non-profit organizations attempt to facilitate technology transfer. State governments, in an effort to promote economic development, have been particularly active in establishing and supporting organizations, often associated with state universities, that provide technology transfer services. Other organizations have also assisted in the establishment of technology transfer centers around the country, again, usually associated with major universities.

As an example, the Technology Extension Service of the University of Maryland works with small- to medium-sized companies in Maryland "to facilitate the dissemination of technical information, help recognize and solve critical problems, provide general guidance and priority identification in approaching longer-term company concerns, and serve as the key interface for industry with [the rest of the University]."¹

Another example is the NASA Industrial Applications Centers (NIACs), located at major universities around the country, which provide similar services on a regional (multi-state) basis. Although NASA is interested in having firms adopt technology developed by NASA, the NIACs' focus is on client needs, so that the information and experts recommended by the NIACs more often than not have no connection to NASA.

These organizations all assist clients in obtaining the information or expertise needed to identify and solve an immediate problem. They typically identify experts who can potentially be of most help to the client, then act as a middleman or broker between the client and the experts. These organizations are responsible for providing information, finding experts, and ensuring that possible solutions are presented to their clients in a usable fashion.

c. Significance to Navy Industrial Facilities

Naval aviation depots and shipyards are large enterprises (hundreds of millions of dollars each in annual activity) engaged in the maintenance and repair of high technology weapon systems. The managers of these facilities are aware that rapid changes in technology outside their facilities provide opportunities for improving the efficiency of their operations. However, before they can take advantage of these opportunities they must somehow learn about specific new technologies and how they can be designed to meet their needs. Unfortunately, these managers are often limited in their efforts to learn about new

¹ From material provided by the University of Maryland Technology Extension Service.

technologies due to a lack of in-house resources. A technology transfer center that helps industrial facility managers to identify specific new technologies and determine how they might be used would be of significant value.

In this environment it is easy to see why technology transfer requiring substantial R&D would not receive a high priority from industrial facility managers. There are many opportunities to take advantage of existing technologies to solve immediate problems; thus industrial activities rarely use scarce resources to fund higher risk R&D projects that won't pay off for many years. Their demands could largely be met, therefore, by technology transfer centers that do not engage in R&D.

3. Types of Technology Transfer

The technology transfer institutions described in the preceding paragraphs perform a variety of technology transfers. The following three basic types of technology transfer can take place in a technology transfer center.

- Transfer without modification
- Transfer with modification
- Transfer after additional R&D.

The primary factor distinguishing these types of technology transfer is the time element. Transfer without modification is something that can occur immediately, or in the very short term, by simply acquiring an existing machine or process. Transfer with modification requires some additional amount of time for the modifications to be completed, so it may be viewed as occurring over the medium term. Finally, transfer with additional R&D can be seen as a long-term endeavor, since by definition basic information required for the solution of the problem is not yet available for application.

a. Transfer Without Modification

In many cases the transfer of a device or process from one organization to another can take place without any major technical modifications. Technology transfer in this case is relatively easy, once the organization to receive the technology is aware of its existence, since the technology need not be (significantly) altered to fit the circumstances of the receiving organization. The simplest example of such technology transfer is when one organization informs another of a specific machine or process that could be purchased and

installed immediately to solve a particular problem or improve the organization's productivity. Once again, this may be seen as a short-term process.

b. Transfer With Modification

A more difficult form of technology transfer occurs when a device or process must be significantly modified before the receiving organization can use it. An organization may become aware of a technology that is currently being used to solve one problem and could be modified to solve a similar or related problem. Or a particular technology may be well understood but may never have been used in the application being contemplated by the organization receiving the technology transfer. This is the most difficult category of technology transfer for industrial organizations. Technology transfer organizations catering to industrial clients spend a great deal of effort trying to match their client needs with existing technology that might be successfully adapted to solve the problem at hand, and outside experts are often used to formulate such possibilities. This type of technology transfer is a short- to medium-term process.

c. Transfer After Additional R&D

There are some instances in which no technology is currently available that can be used directly or in modified form to meet the needs of the technology transfer recipient. In such cases, additional R&D must be performed before the technology will be ready for a particular industrial application. The required R&D could be any combination of basic and applied research; however, if basic research is necessary, the technology is probably further from industrial application than if only applied research is required. In either case this type of technology transfer is a long-term process.

Aside from organizations actively involved in research and development programs, such as the NSF's engineering research centers and associated private firms, technology transfer organizations rarely engage in technology transfer after additional R&D. Because technology transfer without modification is relatively easy to arrange, technology transfer centers devote a good deal of their resources to helping their clients realize technology transfer with modification. Some technology transfer centers, such as some of the NASA industrial applications centers, do coordinate R&D efforts on behalf of their clients. These efforts differ, however, from conducting in-house R&D.

4. Activities of a Technology Transfer Organization

There are three basic types of activities that a technology transfer center might engage in:

- Providing information
- Organizing an effort to identify a problem
- Organizing an effort to solve a problem.

All technology transfer organizations provide information, some are engaged in problem identification activities, and very few are involved in problem-solving efforts. It should be noted that the information that is provided or the problems that are identified and solved are often not solely technical in nature. They also involve information and advice on management and manufacturing process problems.

All technology transfer centers have mechanisms with which to provide their clients technical and other information. In many cases this information comes from a search of data bases a center maintains or has access to. The large number of computerized data bases available around the world can provide a wealth of information to those who know how to gain access to them and use them efficiently. In addition to technical and other information available through data bases, many technology transfer centers refer their clients to university researchers. Some centers refer clients primarily to the faculty at one university, others may draw on university personnel from an entire state or region. Clients may also be referred to non-university experts. Depending upon how capable the center is in finding experts in a given field and, depending upon what its mission is, references may be made only to local experts or to experts found all over the country.

A technology transfer center may also organize an effort to identify the source of a specific problem for a client. This involves the use of the center's own staff and outside experts, whose efforts are coordinated by the center. To organize problem identification efforts for clients, the center must have a technically competent staff capable of organizing and conducting an investigation into an applied technology problem. The capabilities and resources necessary for problem identification efforts exceed the requirements for providing technical information and references.

Because of the wide range of technical problems that a technology transfer center faces, maintaining a staff whose expertise covers every technology is not possible. Instead, the technology transfer center seeks to maintain a core staff with extensive

technical expertise; this core staff then relies on outside experts to provide much of the detailed, specialized analysis of individual problems. The outside experts usually provide the client with a written assessment of the technical solution or characterization of the problem. In some cases, this analysis may include a feasibility study describing the client's options and future courses of action.

In addition to performing the functions described in the preceding paragraphs, some technology transfer centers are also capable of overseeing the implementation of the solution. For example, if the solution to the problem involves technology transfer in which an existing technology must be modified before it can be used by the client, the technology transfer center might oversee (manage) the modification effort and follow through until the technology has been successfully installed by the client. In cases requiring additional R&D before technology transfer can be effected, the center might also manage the R&D aspects of the project.

5. Summary

The matrix provided in Figure 1 summarizes the types and attributes of technology transfer centers. The potential activities of a technology transfer center are listed across the top of the matrix, and the three basic types of technology transfer are listed along the side. The operations of most technology transfer centers can be categorized by the four cells in the upper left-hand corner of the matrix (cells A1, A2, B1, and B2); they are primarily engaged in providing information and identifying problems for technologies that can be transferred without or with modification (in the short to medium term). The Engineering Research Centers and the S&T Centers supported by the NSF are engaged in activities characterized by the bottom row of the matrix (cells A3, B3, and C3); they engage in a number of activities geared primarily towards long-term R&D. The activities of several of the NASA Industrial Applications Centers cover the categories contained in all nine cells of the matrix, although they organize and manage R&D without actually conducting it themselves.

The University of Michigan demonstration project, to be discussed in the next section, fits primarily into the two cells at the bottom of the right-hand column of the matrix (cells C2 and C3). The project was initially a long-term R&D project (cell C3), designed to provide a solution to a particular problem at the Naval Aviation Depot (NADEP) in Norfolk, Virginia. Eventually, the project involved the modification of existing technology

	A. Provide Information	B. Identify Problem	C. Provide Solution
1. Without Modification			
2. With Modification			
3. With R&D			

Figure 1.

to solve the problem (cell C2). It also involved, during the last few months of the study, an effort to provide information on, identify, and perhaps provide solutions to, a longer list of problems suggested by Norfolk. Such an effort covers all of the cells in the matrix.

B. THE UNIVERSITY OF MICHIGAN PROJECT AND REPORT²

1. Introduction

The efforts of the University of Michigan's technology transfer project during the past three years have concentrated on a technical research project. The project began as a long-term R&D project to provide a solution to a problem at the NADEP. The project involved attempts to apply ultra-violet (UV) technology to the detection and welding of microscopic cracks in jet engine components. After nearly two years of effort it was determined that the UV technology would not yield promising results in the foreseeable future, so the project was re-oriented towards the enhancement of existing (though still advanced) technology in detection and weld techniques. With reference to the matrix in Figure 1, the Michigan research project's initial efforts can be categorized by cell C3, providing a solution through the conduct of R&D. The project then expanded to providing a solution through the modification of existing technology (cell C2).

An additional activity undertaken by the University of Michigan in recent months has been the assessment of a list of problems provided to them by officials at NADEP. For each problem, the University of Michigan may provide information, identify the problem,

² This section is based upon a draft report submitted to the Navy in November 1988 by Professor Bain Carew, et al, entitled "Technology Transfer Center Feasibility Project." For further information on this effort, contact Mr. Jim Rogers, Naval Logistics R&D, Naval Supply Systems Command.

or provide solutions to the problem. It is envisioned that this could occur by transferring advanced technology without modification, with modification, or with additional R&D, although the primary focus of Michigan's efforts seems to be on providing R&D solutions to problems. Referring to the matrix in Figure 1, this portion of the Michigan effort clearly covers all the cells in the matrix. Because this part of the demonstration project has just begun, no results have been obtained from this activity. Thus the draft report submitted by Michigan deals primarily with the original R&D project.

The research Michigan performed is a technology transfer effort in the broad sense that any contract for R&D, if successfully completed, involves the (eventual) transfer of technology. Because they concentrated on a single, long-term research project and because they did not review the structure and experiences of existing technology transfer organizations in the United States, the Michigan report provides a rather narrow assessment of the potential benefits to the Navy of technology transfer centers. Its recommendations are limited in terms of the types of technology transfer that might be undertaken by a technology transfer center and the activities of such a center.

2. Types of Technology Transfer

Of the three types of technology transfer outlined earlier in this paper--transfer without modification, transfer with modification, and transfer after additional R&D--the Michigan report concentrates on transfer after additional R&D (the third row of the matrix). However, most Navy industrial facilities have relatively little demand for this type of technology transfer. The transfer of advanced technology requiring little or no modification seems to be of far greater priority to these facilities than longer term, higher risk R&D projects. The Navy needs full-scale technology transfer centers that can perform technology transfer with and without modification to fully meet its requirements. If instead of being "general purpose" in nature a technology transfer center concentrates on providing R&D services, then it is, in essence, a highly specialized technology transfer center of a type not required by Navy industrial facilities.³

³ The RAMP program is an example of a highly specialized R&D effort. However, it is best described as a technology transfer project, not a technology transfer center, because it is dedicated solely to this effort and does not undertake other R&D projects for the Navy's industrial activities.

3. The Activities of a Technology Transfer Center

Of the three major activities undertaken by technology transfer centers--providing information, identifying problems, and providing solutions to problems--the Michigan experience focuses on providing solutions (the third column in the matrix). This is, again, only one of several functions that a technology transfer center might undertake, although it corresponds with the experiences of the University of Michigan during its three-year demonstration project. The report's recommendations for establishing technology transfer centers, however, draws conclusions and makes more detailed recommendations regarding the other two types of activities that such centers might engage in--providing information and identifying problems--as well as recommendations on how a center could provide solutions to clients' problems.

A more thorough review of the structure and experiences of numerous existing technology transfer centers would have been particularly helpful. For example, the University of Michigan researchers appear to have underestimated the difficulty of conducting automated data base searches. To build strong capabilities in providing technical information and information on experts in various technical fields, a technology transfer center must have many years of experience. (This is evident in the experiences of the Federal Lab Consortium and of the NASA Industrial Applications Centers.) In this context, the discussion in the Michigan report on ways to find experts is not satisfactory and should have drawn more on the years of experience of numerous other organizations.

In addition to providing information for clients, many technology transfer centers assist in the identification of client problems. A center does not usually have the full technical expertise for offering such assistance, so the center's staff must often be augmented by outside experts. This suggests that a technology transfer center must have a staff with a mix of technical skills to meet a wide range of client needs, the ability to assess a problem and determine what kinds of experts are required, the ability to find those experts, the ability to organize the experts' efforts, and the ability to provide clients with useful information and analyses.

Again, there are many technology transfer centers in the country whose experiences provide valuable insights into how to organize and manage a technology transfer center with these needs in mind. Michigan's recommendations should have taken into account the experiences of other technology transfer centers in problem identification, rather than focus

solely on the lessons learned from providing a solution to one technical problem presented by NADEP Norfolk.

Many technology transfer centers assist clients in finding solutions to their problems. The Michigan report recommends that technology transfer centers be established with physical facilities that would allow them to perform research, development, and prototyping. The need to establish new facilities to take on this R&D function was not adequately demonstrated in the report, however. If R&D is to be performed on behalf of the Navy industrial facilities, why is a center which conducts R&D preferable to a center which contracts out for and then manages the R&D that is needed? Perhaps by managing the research, instead of actually conducting it, the center would be in a better position to ensure that the best experts available are conducting the actual research. Is there any guarantee that a center performing its own research would always be able to attract the best people in any technical area to perform the necessary research? These are important questions to consider, since they have a direct bearing on the report's conclusions regarding the establishment, organization, and activities of technology transfer centers for the Navy. Once again, the experiences of existing technology transfer centers shed light on these questions and should have been given more consideration in the Michigan report.

4. Summary

In evaluating the recommendation of the Michigan report, the following factors should be considered:

(1) *The Michigan approach provides for a specialized, rather than a general purpose, technology transfer center.* If the Navy wishes to establish a more general purpose set of technology transfer centers that can continuously identify and aid in the solution of a wide range of technology transfer problems, and that meet the larger number of more immediate technological needs of its industrial activities, then the recommendations in the Michigan report are of limited use.

(2) *Much more is known about technology transfer centers than is suggested by the Michigan report.* In evaluating what a technology transfer center should do, how it should be organized, what type of staff and operations it should have, what client needs are, and how those needs can best be served, much could have been learned from the years of experience of dozens of existing technology transfer centers. This is particularly evident in the Michigan report's discussion and recommendations concerning the use of data bases.

the identification of experts, the establishment of physical research facilities, and the proposed management structure (i.e., a board of directors and a CEO) for the centers.

(3) *The functions and capabilities of a technology transfer center take years to establish.* The Michigan report should have given consideration to the possibility of using established technology centers, rather than forming new technology transfer centers. There are great risks associated with starting completely new technology transfer centers. There is a possibility that the quality of the service will be inconsistent the first few years, and there is also the risk of outright failure. Such risks may be unnecessary because organizations that have proven capabilities and might be able to immediately meet the Navy's needs already exist.

(4) *The start-up costs of a new technology transfer center are very high.* In addition to the time needed to form a technology transfer center, establishing a new center, particularly one capable of performing its own research, is a very expensive proposition. Such a center could not be established for less than several million dollars. Once again, the risks involved in embarking on such an expensive program are far greater than is necessary given the existence of other, already successful, technology transfer centers.

C. RECOMMENDATIONS

On the basis of IDA's assessment of the functions of technology transfer centers and the Navy's requirements, it is recommended that the Navy provide its industrial activities with access to technology transfer centers and encourage their use. To get started, a process must be established by which technical proposals from the field activities are given a proper evaluation before being discarded or sent to a technology transfer center for further investigation. It is recommended that the following five steps be taken to develop an effective technology transfer center process in the Navy.

- (1) Industrial logistics R&D proposals must be solicited from each field activity within each Systems Command.
- (2) These proposals must be ranked according to priority within each Systems Command.
- (3) A Navy-wide set of industrial logistics R&D priorities must be established.

- (4) An analysis of each approved, Navy-wide priority must be performed by a technology transfer center.
- (5) Individual research projects must be funded.

This process is illustrated in Figure 2.

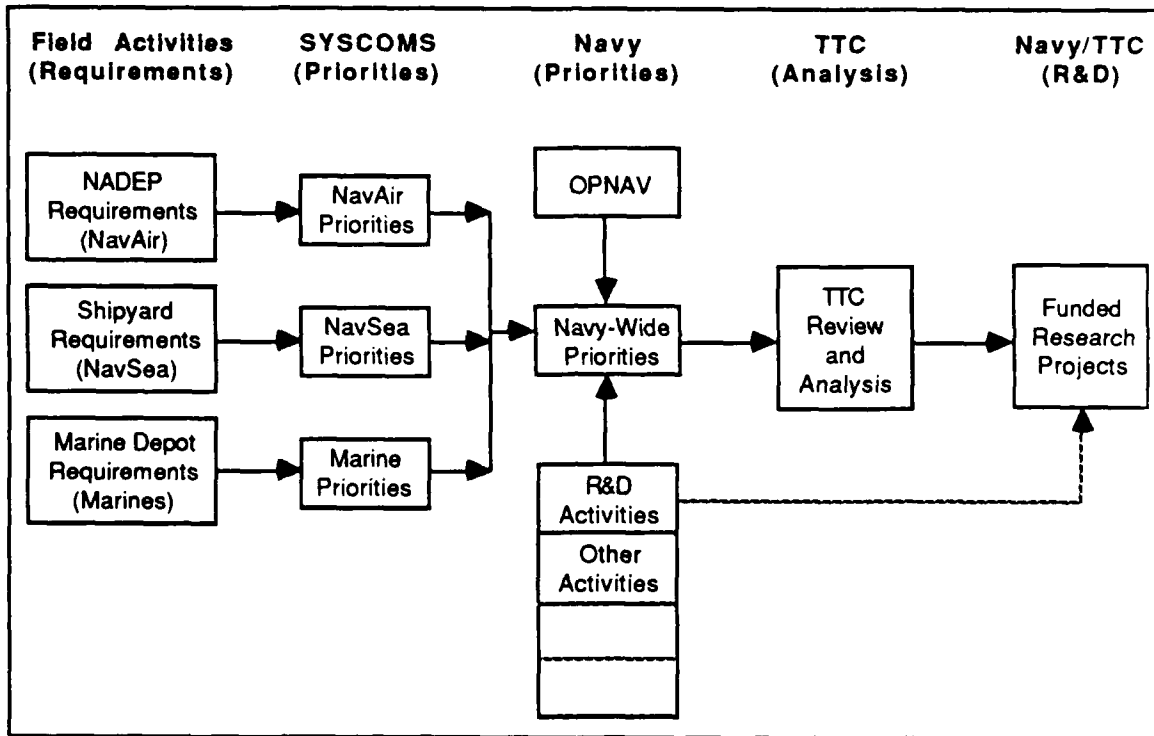

Figure 2.

1. Field Activity Requirements

The first step in developing industrial logistics R&D projects is listing the candidate projects to choose from. This can be done by having each of the Systems Commands request a list of specific projects that their field activities would like to see analyzed by the technology transfer center. Each Systems Command will have its own procedures for soliciting proposals; however, the criteria for these proposals will be established by the Industrial Logistics R&D Board (which is described in Section 3).

2. Systems Command Priorities

The second step is for each of the Systems Commands to analyze and prioritize the list of projects proposed by their field activities. Some proposals might be combined.

others might be left unchanged, and still others might be sent back to the field activities for refinement. Through this step, each Systems Command will develop a list of industrial logistics R&D projects, ranked according to priority, that it believes are the best candidates for analysis and possible funding.

3. Navy Priorities

From the lists of Systems Command priorities, agreement must be reached on a set of Navy-wide priorities. Up to this point the individual Systems Commands will have had little difficulty in using or adapting existing internal procedures to develop their lists of candidate projects. However, to reach Navy-wide agreement on industrial logistics R&D priorities, a new process for cooperation and communication between the Systems Commands and other relevant Navy activities must be implemented.

It is recommended that an Industrial Logistics R&D Board be formed. The Board should include senior representatives from all of the relevant Systems Commands. The Industrial Logistics R&D Board will provide guidelines for the Systems Commands to follow in the solicitation of proposals from the field activities. The Board will meet twice a year to review the R&D projects recommended by the Systems Commands and decide which ones should be forwarded to a technology transfer center for detailed analysis. The Board must review the progress of current projects and consider new projects that may arise during the course of the year.

4. Technology Transfer Center Analysis

Although the technology transfer centers will perform analyses of the R&D projects forwarded to them by the Industrial Logistics R&D Board, their primary points of contact will be the field activities whose projects are approved by the Board. The analysis performed by the technology transfer centers will determine whether and how a particular problem can be solved. The three basic assessments it can make are that the solution to the problem exists and the transfer of a device or process can take place without any major technical modifications; the solution to the problem exists, but the devices or processes in question must be significantly modified before the receiving organization can use it; or there is no technology currently available that can be used directly or in modified form to meet the needs of the technology transfer recipient, and additional R&D must be performed. Navy Logistics R&D funding should be provided for these technology transfer analyses.

5. Funded Research

If the initial analysis performed by a technology transfer center indicates that significant modifications to existing technology or more R&D are needed, the Navy may wish to provide funds for additional work. This work may be contracted for and performed through the usual channels used in such cases or it can be coordinated on the Navy's behalf by the technology transfer center.

6. Initiating the Plan

The process described in the preceding paragraphs can be initiated during fiscal year 1989 if the following steps are taken:

- Funds are made available through the industrial applications centers at the University of Florida and the University of Pittsburgh to act as technology transfer centers.
- Each of the Systems Commands develops, by May 1, 1989, a prioritized list of potential technology transfer projects.
- The Industrial Logistics R&D Board should meet in early May to review the technology transfer projects compiled by each of the Systems Commands.
- Projects approved by the Board should be forwarded immediately to the Technology Transfer Centers for analysis.

Appendix A

**ALTERNATIVE TECHNOLOGY TRANSFER
CENTER APPROACHES**

ALTERNATIVE TECHNOLOGY TRANSFER CENTER APPROACHES

As noted in the preface, one of the reviewers of this paper suggested that alternatives for establishing Technology Transfer Centers, other than that recommended in the paper, are available. One such alternative was outlined by this reviewer:

Establish, within one of the strong *Navy laboratories*, such as the Naval Research Laboratory, a small group of seasoned engineers and scientists, designated as a Technology Transfer Center. Charge the group with the task of consulting with the managers of one or more Navy industrial organizations to identify problems and determining whether available technology, with or without modification, with or without research and development, might solve them. Charge the TTC group, in consultation with the industrial managers, with establishing expected costs, schedules, and priorities, and applying for required funding. Have the TTC group arrange for any necessary R&D, either within its own laboratory or under outside contract. If no R&D is involved, the industrial manager, perhaps with the assistance of the TTC in preparing specifications, may contract directly for services or equipment needed to solve the problem.

DISTRIBUTION
IDA PAPER P-2227

*THE USE OF TECHNOLOGY TRANSFER CENTERS
BY DEPARTMENT OF DEFENSE INDUSTRIAL FACILITIES*

64 Copies

	<u>Number of Copies</u>
Dr. Julius Alker Naval Air Systems Command Code Air 4341B Washington, DC 20361	1
Mr. Tom Bahan President, Bahan Dennis, Inc. 101 Woodman Drive, Suite 10B Dayton, OH 45431	1
Mr. Mike Cocchiola Executive Director, Aviation Depots Naval Air Systems Command Code AIR 43-A Washington, DC 20361-4300	2
Mr. John Crossley Acting Director, Research and Development Center Management Division Space and Naval Warfare Systems Command Washington, DC 20363-5100	1
Mr. Kurt Doehnert Supervisor, Industrial Engineering Office Commander, Naval Sea Systems Command Washington, DC 20362-5101	1
Dr. Paul McWilliams Executive Director NASA Industrial Applications Center 23 William Pitt Union Pittsburgh, PA 15260	2

Mr. Jim Rogers Deputy Director Naval Supply Systems Command 1931 Jefferson David Highway Arlington, VA 22202	3
Mr. Ron Thornton Director for Southern Technologies Applications Center One Progress Boulevard Box 24 Alachua, FL 32615	5
Dr. Leo Young Staff Specialist for Logistics R&D ODDR&E (R&AT/ET) Rm. 3D1089, Pentagon Washington, DC 20301-3080	5
Defense Technical Information Center Cameron Station Alexandria, VA 22304-6145	2
Institute for Defense Analyses 1801 N. Beauregard Street Alexandria, VA 22311	
Gen. William Y. Smith	1
Mr. Philip L. Major	1
Dr. Robert E. Roberts	1
Dr. William J. Schultis	1
Dr. Paul H. Richanbach	25
Dr. Frederick R. Riddell	2
Control and Distribution	10