



REPORT DOCUMENTATION PAGE

Form Approved
OMB No. 0704-0188

Public reporting burden for this collection of information is estimated to average 1 hour per response, including the time for reviewing instructions, searching existing data sources, gathering and maintaining the data needed, and completing and reviewing the collection of information. Send comments regarding this burden estimate or any other aspect of this collection of information, including suggestions for reducing this burden, to Washington Headquarters Services, Directorate for Information Operations and Reports, 1215 Jefferson Davis Highway, Suite 1204, Arlington, VA 22202-4302, and to the Office of Management and Budget, Paperwork Reduction Project (0704-0188), Washington, DC 20503.

AD-A217 301

1. AGENCY USE ONLY (Leave blank)		2. REPORT DATE January 1990	3. REPORT TYPE AND DATES COVERED professional paper																					
4. TITLE AND SUBTITLE DEEP UNDERWATER MUON AND NEUTRINO DETECTION STATUS AND PLANS		5. FUNDING NUMBERS In-house																						
6. AUTHOR(S) H. R. Talkington		8. PERFORMING ORGANIZATION REPORT NUMBER																						
7. PERFORMING ORGANIZATION NAME(S) AND ADDRESS(ES) Naval Ocean Systems Center San Diego, CA 92152-5000		9. PERFORMING ORGANIZATION AGENCY REPORT NUMBER																						
9. SPONSORING/MONITORING AGENCY NAME(S) AND ADDRESS(ES) Naval Ocean Systems Center San Diego, CA 92152-5000		10. SPONSORING/MONITORING AGENCY REPORT NUMBER																						
11. SUPPLEMENTARY NOTES																								
12a. DISTRIBUTION/AVAILABILITY STATEMENT Approved for public release; distribution is unlimited.			12b. DISTRIBUTION CODE																					
13. ABSTRACT (Maximum 200 words) DUMAND, the acronym for deep underwater muon and neutrino detection, is a project started by a group of U.S. physicists to produce a detector large enough to detect a significant rate of very high-energy natural neutrinos. This project will permit the study of elementary particle interactions in cosmic rays at energies beyond those available from contemplated future particle accelerators. It may also allow the observation of extraterrestrial and possibly extragalactic sources of neutrinos. <i>Interview - agreement; Muon/Neutrino detectors. (A DC)</i>																								
<table border="1"> <tr> <td colspan="2">Accession For</td> </tr> <tr> <td>DTIC GRA&I</td> <td><input checked="" type="checkbox"/></td> </tr> <tr> <td>DTIC TAB</td> <td><input type="checkbox"/></td> </tr> <tr> <td>Unannounced</td> <td><input type="checkbox"/></td> </tr> <tr> <td>Justification</td> <td></td> </tr> <tr> <td colspan="2">By _____</td> </tr> <tr> <td colspan="2">Distribution/</td> </tr> <tr> <td colspan="2">Availability Codes</td> </tr> <tr> <td>Dist</td> <td>Avail and/or Special</td> </tr> <tr> <td>A1</td> <td></td> </tr> </table>					Accession For		DTIC GRA&I	<input checked="" type="checkbox"/>	DTIC TAB	<input type="checkbox"/>	Unannounced	<input type="checkbox"/>	Justification		By _____		Distribution/		Availability Codes		Dist	Avail and/or Special	A1	
Accession For																								
DTIC GRA&I	<input checked="" type="checkbox"/>																							
DTIC TAB	<input type="checkbox"/>																							
Unannounced	<input type="checkbox"/>																							
Justification																								
By _____																								
Distribution/																								
Availability Codes																								
Dist	Avail and/or Special																							
A1																								
Published in <i>Proceedings of UJNR Marine Facilities Panel</i> , September 1989.																								
14. SUBJECT TERMS			15. NUMBER OF PAGES																					
			16. PRICE CODE																					
17. SECURITY CLASSIFICATION OF REPORT UNCLASSIFIED	18. SECURITY CLASSIFICATION OF THIS PAGE UNCLASSIFIED	19. SECURITY CLASSIFICATION OF ABSTRACT UNCLASSIFIED	20. LIMITATION OF ABSTRACT UNLIMITED																					

DTIC ELECTE
JAN 30 1990
S E D



DEEP UNDERWATER MUON AND NEUTRINO DETECTION STATUS AND PLANS

Howard R. Talkington

Naval Ocean Systems Center

with
excerpts from
University of Hawaii DUMAND Office
DUMAND II Proposal

Introduction

DUMAND, the acronym for deep underwater muon and neutrino detection, is a project started by a group of U.S. physicists to produce a detector large enough to detect a significant rate of very high-energy natural neutrinos. This project will permit the study of elementary particle interactions in cosmic rays at energies beyond those available from contemplated future particle accelerators. It may also allow the observation of extraterrestrial and possibly extragalactic sources of neutrinos.

For elementary particle research, the energies sought— 10^{14} eV (100,000 billion electron volts) and above—are necessary to probe the structure of particles on the minutest possible scale and to test our presently emerging picture of the fundamental forces of nature. A very large detector is also necessary to make high-energy neutrino astronomy a reality, because of the background of terrestrial neutrinos made by cosmic-ray protons in the earth's atmosphere. At very high energies, the flux from beyond the earth will surely dominate. If the sources that we believe exist do produce an observable flux of extraterrestrial neutrinos, we shall have begun a new field of science and opened a new window upon the universe.

The techniques available for detecting high-energy neutrino collisions in the ocean utilize either the light flash that the particles produce (Čerenkov radiation) or the acoustic pulse they emit (by instantaneously heating a tiny volume of water). The ocean is simultaneously our target detection medium and our shield from external disturbances. The ultimate detector configuration, at 4.8 km depth, may consist of a volumetric array of 22,680 sensors evenly placed on a three-dimensional grid at spacings of about 40 m (130 ft). This detector configuration is presently envisioned as a group of vertical strings of sensors, anchored to the bottom and kept in near-vertical orientation by high tension provided by excess buoyancy at the top

of each string. Initially, primary detection will be concentrated on the optical signals, and the sensors optimized for the optical phenomena. The initial array to be installed beginning in 1991 will consist of 216 optical modules, 9 laser calibrators, and 9 environmental sensor packages.

The placing of large numbers of optical sensors in calibrated positions near the sea floor in depths to 4.3 km, with the connecting instrumentation cabling, and the 40-km long cable run to the shore station, is a major ocean engineering challenge of the 1990's; and is of direct vital interest to the engineers and scientists of the UJNR Marine Facilities Panel. During the development of the DUMAND detector system, the engineering of many portions will require using the "cutting edge" of technology. The following items will be heavily technology-dependent:

- Fiber optic and power undersea cables
- Underwater connectors
- Optical and acoustic sensors
- Precise position monitoring
- In-situ signal processing
- Power supplies and distribution
- Pressure-tolerant electronics
- Lightweight structural frameworks
- Special materials
- Special anchoring

In addition, procedures must be validated for deploying very large arrays in deep water; large quantities of data will be processed in situ to reduce bandwidth for cable economies; unmanned vehicle expertise for inspection and repair of sensors and cabling systems in deep water will be developed; and, finally, procedures must be developed for installing and maintaining deep-sea cables and investigating structural response in long, undersea sensor strings.

The first stage of the DUMAND project has been completed, culminating in successful operations of a Short Prototype String (SPS) of detectors operating at depths to 4000 m. The project is now ready to proceed to the development, installation and long-term operation of an array of multiple strings of optical detectors.

DUMAND Stage I Operating Results

To test our concept and design of components for the future DUMAND project, the Short Prototype String (SPS) experiment was carried out in the Pacific Ocean about 35 km west of the island of Hawaii, during November 1987. The primary purpose of this experiment was to develop the prototype components and then to demonstrate the feasibility of detecting muons in the deep ocean. Seven Čerenkov light detector modules, two calibration light source modules, one environmental sensor module with a sensor unit, two hydrophones, and a String Bottom Controller (SBC) were used for the experiment. The detector modules were attached to the string on a 5.1-m spacing; the whole string stretched about 50 m vertically. Figure 1 shows the actual configuration of the SPS detectors as deployed from the Naval Ocean Systems Center (NOSC) SSP *Kaimalino*. This Small Waterplane Area Twin Hull (SWATH) type craft proved ideal for this type of deployment due to its ultra stability in medium sea states.

The modules and the SBC were deployed from a ship using an electro-optical cable of 7.9 mm diameter. We used a data-taking scheme as close to the real DUMAND scheme as possible. Namely, all the data coming from the modules are sent to the SBC, digitized and multiplexed there, and then sent up to the ship through an optical fiber cable at 50 Mbaud. The data were decoded, processed, and recorded on magnetic tapes onboard the ship. The electric power for all the components was sent from the ship through the cable with a sea water power return. The whole system was controlled from the ship through a 300-baud, slow speed communication link superimposed on the power line.

The data were taken at depths from 2000 m to 4000 m in steps of 500 m. In total, we gathered data for more than 35 hours in real observation time and acquired 1.2 million triggers of cosmic ray muon data, as summarized in Table 1. Along with these data, we obtained much information on the environment of the deep ocean, including the attenuation length of light in the deep ocean.

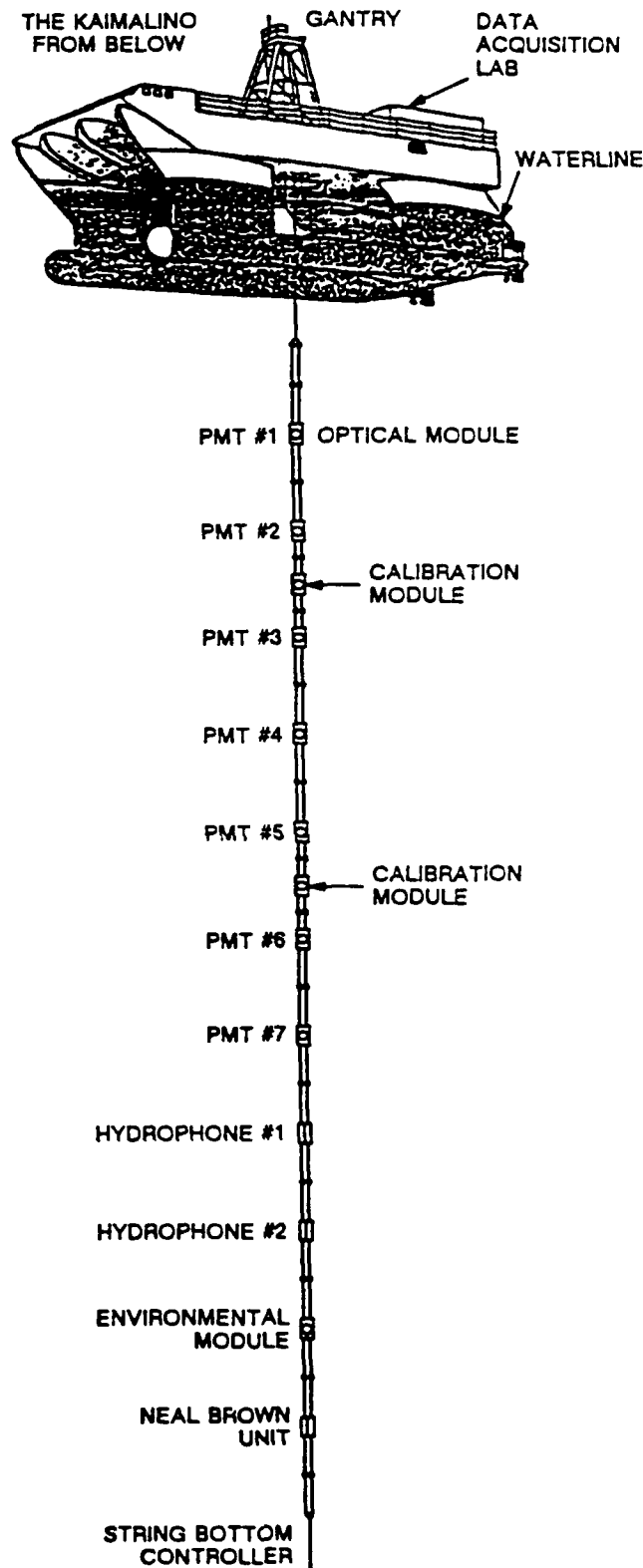

Figure 1: Layout of the short-prototype string, deployed from the SSP *Kaimalino*.

Table 1. Observing time of the SPS string, at different depths and space conditions.

Depth (m)	# of OMs	Total # Triggers (k)	Total observing time (hr:min)
2000	5	106	5:00
2000	7	26	1:28
2500	7	103	4:31
3000	6	249	5:53
3500	7	277	4:10
4000	7	451	14:10

DUMAND II

DUMAND II is a project to build a deep underwater laboratory for the study of various areas including

- high energy neutrino astrophysics, principally the detection of galactic and extragalactic point sources of TeV neutrinos;
- particle physics, via indirect observations of Ultra High Energy (UHE) hadronic interactions in astrophysical objects as well as more direct observations of terrestrial interactions;
- cosmic ray physics, mostly relating to muon and primary composition studies; and, incidentally,
- geophysics and ocean science.

The second stage of the DUMAND project is a 20,000 m² effective area, deep ocean neutrino detection laboratory. We use the term laboratory to emphasize that we are not proposing a single purpose experiment, but the construction of a facility to initiate research in a new domain, that of High Energy Neutrino Astrophysics. The international DUMAND collaboration, from the USA, Japan, and Europe, plans that this first long term deep ocean emplaced array be constructed and deployed over a period of 3 years, at a cost of about \$9M, with the beginning of regular neutrino astrophysics observations in the early 1990's.

The international DUMAND collaboration consists of the following people: P. Bosetti - Technische Hochschule Aachen, West Germany; P.K.F. Grieder - University of Bern, Switzerland; B. Barish and J. Elliott - California Institute of Technology, USA; J. Babson, R. Becher-Szendy, J.G. Learned, S. Matsuno, D. O'Connor, A. Roberts, V.J. Stenger, V.Z. Peterson, and G. Wilkins - University of Hawaii, USA; O.C. Allkofer, P. Koske, M. Preischl, and J.

Rathlev - University of Kiel, West Germany; T. Kitamura - Kinki University, Japan; H. Bradner - Scripps Institute of Oceanography, USA; K. Mitsui, Y. Ohashi, and A. Okada - Institute of Cosmic Ray Research, University of Tokyo, Japan; J. Clem, C.E. Roos, and M. Webster of Vanderbilt University, USA; U. Camerini, M. Jaworski, R. March, and R. Morse - University of Wisconsin, USA.

The proposed location, size, and configuration for the laboratory have been chosen after extensive analysis and experimentation as the simplest and least expensive technique which can do unique and important high energy neutrino physics and astrophysics. In addition, it will have a significant capability in high energy cosmic ray physics and ocean science. The design is intentionally flexible, and can be expanded as the science warrants, with the long range goal of achieving an array of ~1 km³.

The site proposed for the array is almost directly west of Keahole Point on the island of Hawaii, in a subsidence basin, the "Kahoolawe Deep," at a depth of 4.8 km, 35 km from shore. The array cables will emerge from the ocean directly at the Natural Energy Laboratory of Hawaii (NELH), a State of Hawaii facility at Keahole Point. The DUMAND shore lab will be located at NELH, which already has adequate power and lab space. The Keahole Airport, which serves the nearby Kona resort area, is a short distance away on the same point of land. Nearby is Kawaihae Harbor, with full container facilities. The location is ideal, shielded from the prevailing winds by the island, with very moderate swells and little currents. The site has been extensively explored over the last decade, and has been found to be adequate to our needs (water quality actually better than first expectations). Early concerns about biofouling and bioluminescence have been investigated and we have found that neither presents a serious problem.

The overall concept of the experiment is illustrated in Figure 2. A schematic view of the proposed array is pictured in Figures 3 and 4. Its main properties are summarized in Table 2. Basically, the proposed design consists of 9 vertical strings, each with 24 photomultiplier detectors spaced 10 m apart along the string vertically for 230 m, and with the strings spaced 40 m apart horizontally in an octagonal configuration. This gives a total of 216 detectors and a neutrino-induced muon detection solid angle area of 148,000 m²sr and contained mass of 1.8 megatons.

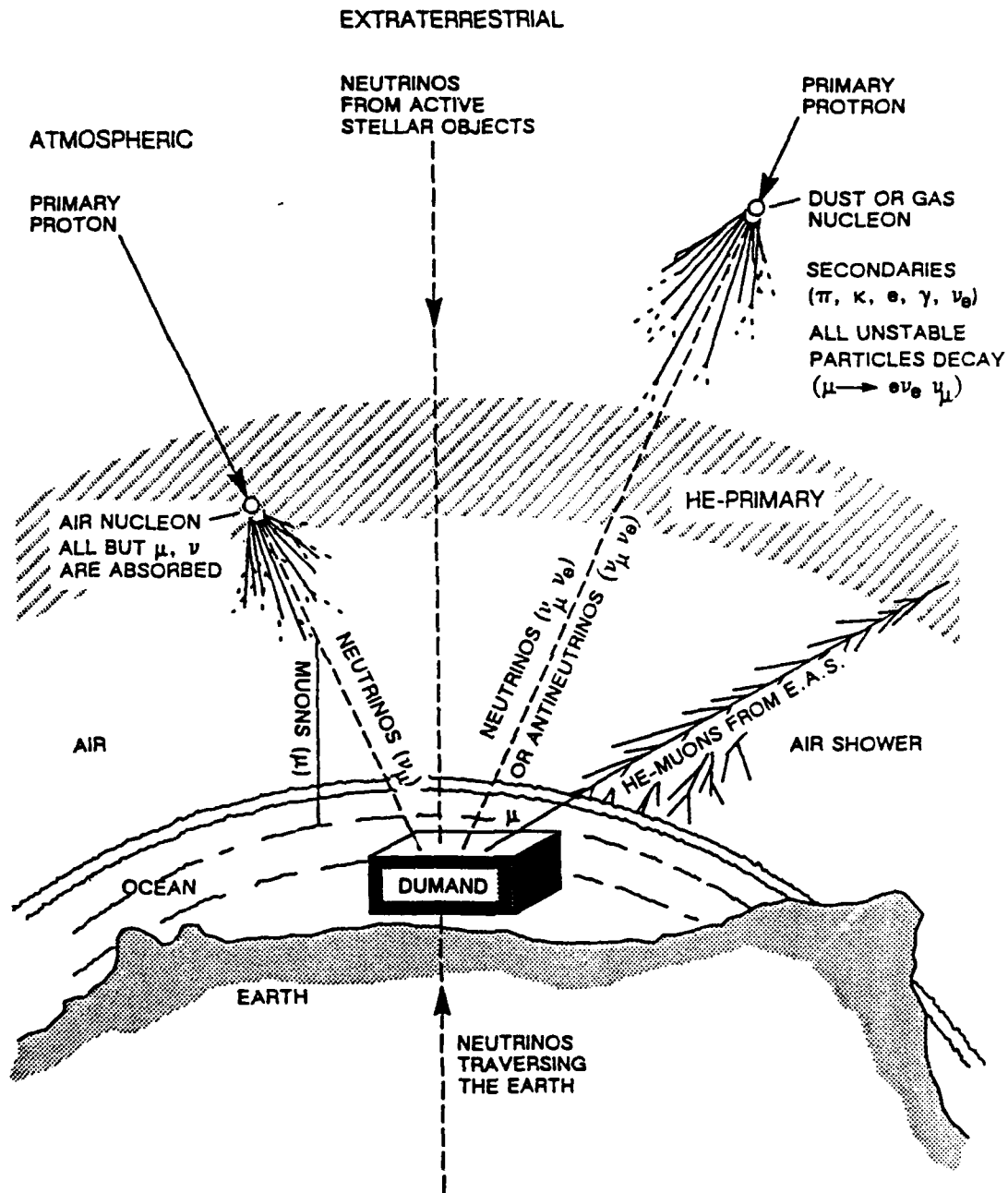

Figure 2: DUMAND experiment concept. Cosmic ray protons (or other nuclei) of very high energy strike matter, either in the earth's atmosphere or elsewhere in the cosmos. The resulting hadronic secondaries decay into neutrinos which penetrate to the DUMAND array and are detected. Down-going muons produced in the atmosphere with energy greater than ~ 3 TeV can also be detected and analyzed.

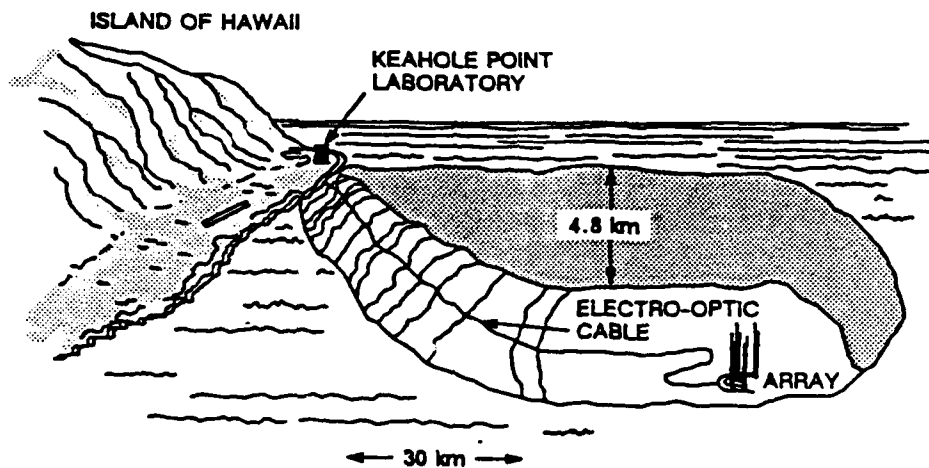

Figure 3: Disposition of the DUMAND detector at 4.8 km depth in subsidence basin ~ 35 km off Keahole Point, island of Hawaii. Armored cables carrying power and fiber-optics communication connect DUMAND to the shore station.

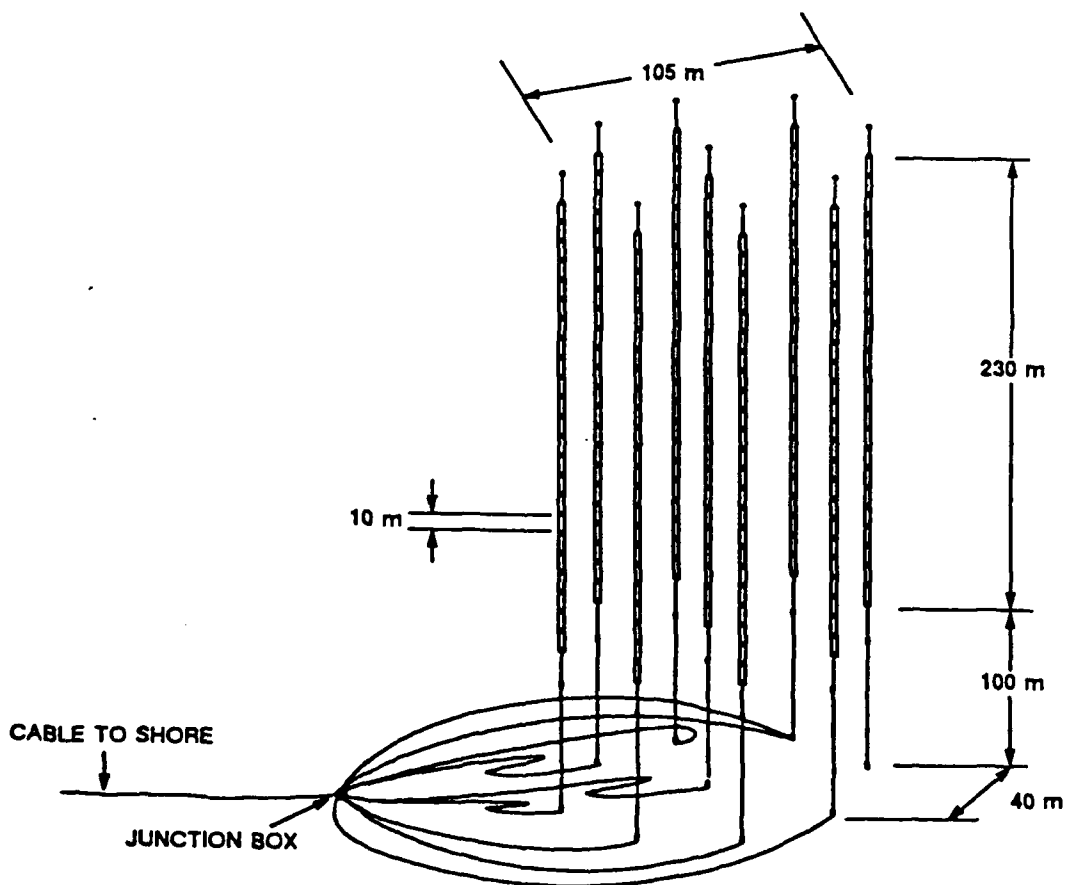

Figure 4: The DUMAND Octagon Array. There are 9 strings, each anchored at the bottom, and held taut by a float. They are spaced 40 m apart on the perimeter, with a ninth in the center. Along each string are 24 detector modules spaced 10 m apart. The strings are independent - they are connected at the bottom.

Table 2. Summary of the physical characteristics of the array.

Property	Characteristic
Array dimensions	100 m diameter \times 230 m high
String spacing	40 m side
Number of strings in array	8 in octagon, 1 in center
Sensor spacing along strings	10 m
Number of optical sensors/string	24
Total number of optical sensors	$9 \times 24 = 216$
Height of first sensor above bottom	100 m
Depth of bottom	4.8 km
Sensor pressure envelope	17-inch (43.2 cm) O.D. glass sphere
Optical sensor	16-inch photomultiplier
Volume of array, contained	$1.8 \times 10^6 \text{m}^3$
Target area for through-going muons	23,000 m^2 horizontal, 7,850 m^2 vertical up-going, 25,500 m^2 downgoing
Effective target volume for 2 TeV muons	$1.0 \times 10^6 \text{m}^3$
Effective target volume for 1 TeV cascades	$7.0 \times 10^5 \text{m}^3$
Muon energy threshold	20 to 50 GeV
Track reconstruction accuracy	$0.5^\circ - 1.0^\circ$
Cascade detection threshold	$\sim 1 \text{TeV}$
Downgoing muon rate	3/minute
Atmospheric neutrino rate for throughgoing muons	3500/yr
Atmospheric neutrino rate for contained events above 1 TeV	50/yr
Point source sensitivity	$4 \text{ to } 7 \times 10^{-10} \text{cm}^{-2} \text{sec}^{-1}$ in a year above 1 TeV
Contained event sensitivity	$1 \times 10^{-8} \text{cm}^{-1} \text{sec}^{-1}$ in a year above 1 TeV

The array design being proposed has been optimized for the detection of high-energy muons from neutrino interactions. Calculations indicate that this gives us the best opportunity for detecting extraterrestrial neutrino sources. The detector spacings, 40 m horizontally and 10 m vertically, ensure that muons with energy $\geq 50 \text{ GeV}$ which pass through from outside, will be detected with high efficiency and reconstructed in direction with better than 1-degree accuracy. (The original neutrino direction will be within this error for neutrino energies above about 1 TeV. Moreover, the relatively flat spectrum sources observed in VHE and UHE gamma rays imply mean observed neutrino interaction energies greater than 1 TeV.) Further, the chosen dimensions allow a significant effective detector volume to be achieved with a modest number of photomultiplier tubes, and thus to have a useful event rate and adequate sensitivity to detect extraterrestrial sources at their expected flux level. A closer spacing—of the order of a few meters—would have been appropriate had we wished to optimize for the detection and reconstruction of lower energy hadronic and electromagnetic cascades. However, future expansion could easily incorporate strings with smaller detector spacing.

No present or planned underground detector is large enough to have a good chance of seeing high energy extraterrestrial neutrino sources. The second stage of DUMAND will be about two orders of magnitude more sensitive than previous detectors underground.

Basic to the DUMAND system is the light detector modules. We have developed a Čerenkov light detector module for deep underwater use. We converged on a module design which was successfully used in the Short Prototype String (SPS) experiment. The module employs a 15-inch (382-mm) hemispherical photomultiplier tube (PMT) as a Čerenkov light detector, which is enclosed in a 17-inch (432-mm) Benthos pressure housing along with special electronic circuitry. The module has been satisfactorily tested in the ocean down to 4000 m depth.

The cross-sectional view of the detector module used for the SPS experiment is shown in Figure 5. All circuit elements are located on a two-tier mount consisting of two annular circuit boards around the neck of the PMT. DC-DC converting power supplies which generate $\pm 5 \text{ V}$ and $\pm 15 \text{ V}$ from the +48 V input are on separate boards attached to the periphery of the larger circuit board. The output pulse of the module is

sent through the optical feed-through shown at the right hand side in the figure. The power for the module is supplied along with a communication line and a ground line through the electrical feed-through shown at the left hand side of the figure.

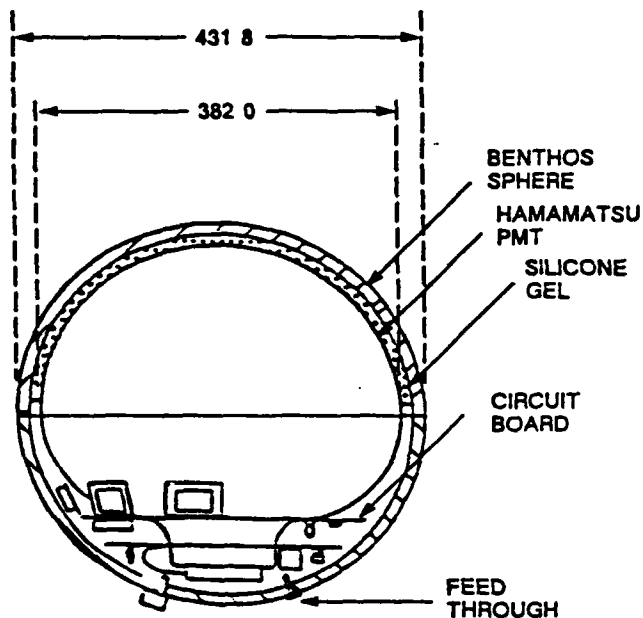

Figure 5: Cross-sectional view of the DUMAND optical module.

The basic tasks of the detector module are listed here:

1. Detect Čerenkov light generated by a muon in the water.
2. Convert the Čerenkov light signal to a semi-digital pulse to be sent through the fiber optic cable.
3. Monitor the counting rate, and suppress output during periods of high bioluminescence.
4. Respond to control and monitoring commands from outside via a communication link.

Conclusion

This project should be of particular interest to the group of engineers and scientists of the UJNR Marine Facilities Panel. We are all involved, in one way or another, with marine facilities. This array is to be deployed in the mid-Pacific area, and operated by a collaboration including many USA and Japanese scientists. The design, development, test and installation is a tremendous challenge to the undersea engineers. Following the development and deployment of the Stage II DUMAND array will be a most interesting exercise for us, and many of us will be called on to assist as consultants, applying our knowledge and experience in the field of deep ocean engineering and marine facilities.