



AD _____

AD-A217 634

FEASIBILITY STUDY: A DEVICE TO INFUSE HYPERTONIC
SOLUTIONS INTO BONE MARROW

Final Report

15 June 88 - 14 June 89

Robert A. Gunther, Ph.D.

George C. Kramer, Ph.D.

September 15, 1989

Supported by

U.S. Army Medical Research and Development Command

Fort Detrick, Frederick, Maryland 21701-5012

Contract No. DAMD17-88-C-8127

Departments of Surgery and Human Physiology
School of Medicine
University of California
Davis, CA 95616

SDTIC
ELECTE
FEB 06 1990
E D
Ca

Approved for public release; distribution unlimited

The findings of this report are not to be construed as the official Department of the Army position unless so designated by other authorized documents.

90 02 06 275

REPORT DOCUMENTATION PAGE				Form Approved OMB No. 0704-0188	
1a. REPORT SECURITY CLASSIFICATION Unclassified		1b. RESTRICTIVE MARKINGS			
2a. SECURITY CLASSIFICATION AUTHORITY		3. DISTRIBUTION/AVAILABILITY OF REPORT Approved for public release; distribution unlimited			
2b. DECLASSIFICATION/DOWNGRADING SCHEDULE					
4. PERFORMING ORGANIZATION REPORT NUMBER(S)		5. MONITORING ORGANIZATION REPORT NUMBER(S)			
6a. NAME OF PERFORMING ORGANIZATION The Regents of the University of California, Davis		6b. OFFICE SYMBOL (If applicable)	7a. NAME OF MONITORING ORGANIZATION		
6c. ADDRESS (City, State, and ZIP Code) 275 Mrak Hall Davis, CA 95616		7b. ADDRESS (City, State, and ZIP Code)			
8a. NAME OF FUNDING/SPONSORING ORGANIZATION U.S. Army Medical Research & Development Command		8b. OFFICE SYMBOL (If applicable)	9. PROCUREMENT INSTRUMENT IDENTIFICATION NUMBER Contract No. DAMD17-88-C-8127		
8c. ADDRESS (City, State, and ZIP Code) Fort Detrick Frederick, Maryland 21701-5012		10. SOURCE OF FUNDING NUMBERS			
		PROGRAM ELEMENT NO.	PROJECT NO.	TASK NO.	WORK UNIT ACCESSION NO.
11. TITLE (Include Security Classification) "Feasibility Study: A device to infuse hypertonic solutions into bone marrow"					
12. PERSONAL AUTHOR(S) George C. Kramer, Ph.D., Robert A. Gunther, Ph.D.					
13a. TYPE OF REPORT Final Report		13b. TIME COVERED FROM 6/15/88 TO 6/14/89	14. DATE OF REPORT (Year, Month, Day) 1989 Sept. 15		15. PAGE COUNT 8
16. SUPPLEMENTARY NOTATION					
17. COSATI CODES			18. SUBJECT TERMS (Continue on reverse if necessary and identify by block number) Hemorrhage, Shock, Resuscitation, Dextran, Hypertonic Saline, Sheep, Intraosseous, RA-27 SHEEP		
FIELD	GROUP	SUB-GROUP			
06	05				
06	04				
19. ABSTRACT The development of small volume resuscitation formulations makes intraosseous infusion an attractive alternative to intravenous cannulations. We performed studies to evaluate the feasibility of developing a device which would allow military corpsmen to rapidly, safely and effectively infuse hypertonic saline/ dextran solution into bone marrow. The following results are from studies with unanesthetized and anesthetized sheep or cadavers. A 2-4 minute intraosseous infusion of 200 ml of 7.5% NaCl/6% dextran 70 (HSD) can effectively resuscitate hemorrhaged sheep. Intraosseous infusion of isotonic fluid for treatment of significant hemorrhage is impractical because of the excessive time or pressure required to deliver adequate volumes; however, effective volume expansion can be achieved with a 2-4 min, syringe-delivered small volume (4 ml/kg) of hypertonic saline dextran. From the study of plastic cast resulting from the injection of Bateson's medium into the sternum of sheep or cadavers, we conclude that intraosseous infusion into the sternum provides direct vascular access via the thoracic veins in both man and sheep. No functional or histological evidence of pulmonary embolism from marrow tissue was found in sheep following rapid intraosseous infusions of HSD. A prototype device which installs onto the midline of the manubrium or sternal body was designed and constructed to deliver low volume, concentrated saline/dextran solutions into the red bone marrow.					
20. DISTRIBUTION/AVAILABILITY OF ABSTRACT <input checked="" type="checkbox"/> UNCLASSIFIED/UNLIMITED <input type="checkbox"/> SAME AS RPT <input type="checkbox"/> DTIC USERS			21. ABSTRACT SECURITY CLASSIFICATION Unclassified		
22a. NAME OF RESPONSIBLE INDIVIDUAL Mary Frances Bostian		22b. TELEPHONE (Include Area Code) 301-663-7325		22c. OFFICE SYMBOL SGRD-RMI-S	

TABLE OF CONTENTS

<u>Title</u>	<u>Page No.</u>
Foreword	1
Summary	2
Specific Aims	3
Research Summary	4
References	7
List of Publications	8

Accession For	
NTIS GRA&I	<input checked="" type="checkbox"/>
DTIC TAB	<input type="checkbox"/>
Unannounced	<input type="checkbox"/>
Justification	
By _____	
Distribution/	
Availability Codes	
Dist	Avail and/or Special
A-1	

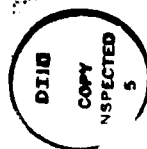

FOREWORD

In conducting research using animals, the investigator(s) adhered to the "Guide for the Care and Use of Laboratory Animals," prepared by the Committee on Care and Use of Laboratory Animals of the Institute of Laboratory Animal Resources, National Research Council (DHEW Publication No. (NIH) 86-23, Revised 1985).

Citations of commercial organizations and trade names in this report do not constitute an official Department of the Army endorsement or approval of the products or services of these organizations.

SUMMARY

1. A 2-4 minute intraosseous infusion of 200 ml of 7.5% NaCl/6% dextran 70 (HSD) can effectively resuscitate hemorrhaged sheep.
2. Intraosseous infusion of isotonic fluid for treatment of significant hemorrhage is impractical because of the excessive time or pressure required to deliver adequate volumes; however, effective volume expansion can be achieved with a 2-4 min, syringe-delivered small volume (4 ml/kg) of hypertonic saline dextran.
3. From the study of plastic cast resulting from the injection of Bateson's medium into the sternum of sheep or cadavers, we conclude that intraosseous infusion into the sternum provides direct vascular access via the thoracic veins in both man and sheep.
4. No functional or histological evidence of pulmonary embolism from marrow tissue was found in sheep following rapid intraosseous infusions of HSD.
5. A prototype device which installs onto the midline of the manubrium or sternal body was designed and constructed to deliver low volume, concentrated saline/dextran solutions into the red bone marrow.

SPECIFIC AIMS

Animal investigations in our lab (1,2,3,4) and those of others (5,6,7,8) have established that small volume infusions of hypertonic saline can effectively restore cardiovascular function after hypovolemic shock. The development of small volume resuscitation formulations makes intraosseous infusion an attractive alternative to intravenous cannulations. We are performing a feasibility study to evaluate the possible development of a device which would allow military corpsmen to rapidly, safely and effectively infuse hypertonic saline/dextran solution into bone marrow. This device would shorten the time delay normally experienced in gaining intravenous vascular access with catheters. Our overall aim of this contract is to perform the initial engineering studies to determine the design specifications required for development of an effective bone marrow infusion device. Specific aims of this one year feasibility study are:

- 1) Preliminary evaluation of the efficacy and safety of intraosseous HSD resuscitation of hemorrhage using a bone marrow needle.
- 2) Determine the anatomical variability of possible infusion sites and the pressure-flow relationships of different resuscitation solutions infused into different bone marrow sites.
- 3) Perform initial evaluations of any pathological effects of intraosseous infusion of hypertonic formulations.
- 4) Develop a prototype injection device which allows intraosseous infusion of 50-250 ml of hypertonic saline dextran over 2-5 minutes.

RESEARCH SUMMARY

Our research on hypertonic saline dextran (HSD) resuscitation and intraosseous resuscitation has resulted in 1 published manuscript and 5 published abstracts. The following is a summary of our work which is organized to relate directly to the numbered specific aims listed on the previous page for contract DAMD-17-88-C-8127.

1. Efficacy of intraosseous resuscitation with HSD (published manuscript M1, abstract A1)

Infusion of 250 ml of 7.5% NaCl Dextran 70 (HSD) is an effective treatment of hypovolemia in trauma patients. However, the significant time delay associated with establishment of intravenous access may limit the usefulness of pre-hospital resuscitation with HSD. Infusion directly into red bone marrow is a rapid means to achieve intravascular access. In this study, we examined the cardiovascular response to a 2 hr hemorrhage (shed blood volume = 38 ± 7 ml/kg) and resuscitation by a 2 min infusion of 200 ml of HSD directly into the sternal marrow of 6 unanesthetized sheep: six control sheep were resuscitated with i.v. HSD. Mean results \pm SD are shown for mean arterial pressure (AP). Cardiac output (CO) and plasma sodium ([Na]) in figure 1.

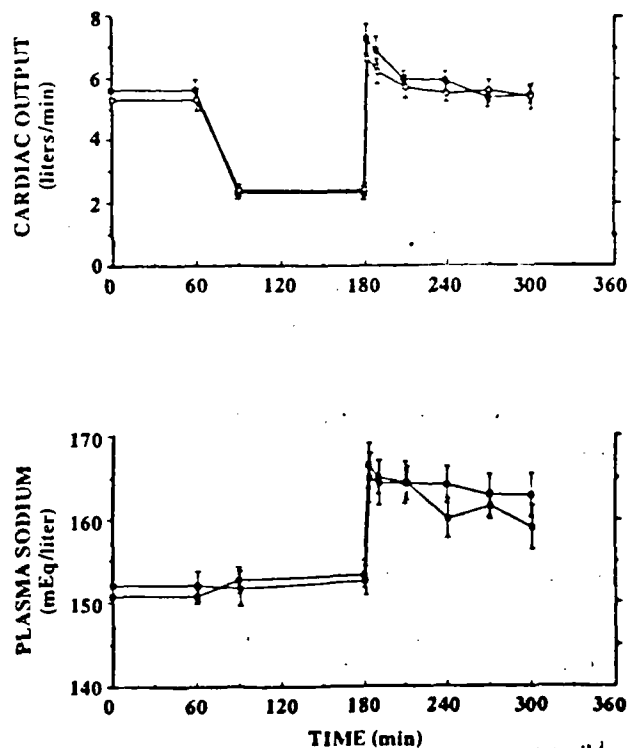

Figure 1 - Mean (\pm SEM) cardiac output and plasma sodium in hemorrhaged sheep resuscitated with 200 ml of hypertonic saline/dextran administered by intraosseous infusion (-■-) and peripheral vein infusion (-□-).

2. Anatomical variation and pressure flow relationships of intraosseous resuscitation (published abstracts A2 and A3).

Intraosseous injections (IOI) of 7.5% NaCl/6% Dextran (HSD) have been proposed as a rapid means of gaining vascular access and delivering fluids to hypovolemic patients. In the present study, Batson's medium was injected into the sternums of sheep

that had been hemorrhaged, resuscitated with IOI of HSD via bone marrow needle, and sacrificed with pentobarbital overdose. The injection of 100-200 ml of Batson's medium was made using a 13 gauge needle at the same site used for the IOI. After the bone and soft tissue were macerated, the resulting plastic cast demonstrated the vascular route of internal IOI. Batson medium filled the marrow for 3-8 cm around the needle and both of the internal thoracic veins. In order to assess the feasibility of doing similar IOI of HSD in hypovolemic patients, studies of human cadaveric sternums were conducted that were similar to those done in the sheep. The sternums were obtained from either embalmed or unembalmed cadavers and injected with Batson's injection medium in the median plane opposite the third intercostal space. The casts obtained from these studies demonstrated the same vascular route in the human that was described above for the sheep. In addition, the sternums of six cadavers were sectioned in the horizontal plane and the dimensions of the marrow space were measured. At the second and third intercostal spaces the dimensions of the marrow space ranged from 26-31 mm laterally and 6-11 mm anteroposteriorly. The cortical bone ranged from 1.5-2.5 mm in thickness. In conclusion, intraosseous infusion into the sternum provides direct vascular access via the thoracic veins in both man and sheep.

Because the practical limitation of intraosseous infusion of resuscitation fluids appears to be the rate of fluid delivery, we examined the pressure-flow relationship of intraosseous infusions. Six anesthetized sheep each had its sternum punctured with a 14 gauge needle which was connected to a Harvard infusion pump. Fluids infused were 0.9% NaCl; 7.5% NaCl/6% dextran 70 and a near saturated, viscous 25% NaCl/24% dextran solution. Infusion rates were varied from 5-70 ml/min, while driving pressures were measured from a side port. Pressures produced at the same flow rate were affected by slight movement of needle position, but at each position a linear pressure flow curve could be generated.

Table 1 shows the time required to deliver an effective volume of each fluid at different driving pressures.

Time to Deliver Resuscitation Volume

Solution	Dose	100 mm Hg	300 mm Hg	1000 mm Hg
Normal Saline	2000 ml	210 min.	70 min.	21 min.
7.5% NaCl 6% Dex	250 ml	36.5 min.	12.2 min.	3.7 min.
25% NaCl 24% Dex	50 ml	15.2 min.	5.1 min.	1.5 min.

Pressures generated by gravity flow (~100 mm Hg) or i.v. pressure bag (~300 mm Hg) are inadequate to deliver resuscitation fluid into the bone marrow at the rapid rates required by trauma patients. Intraosseous infusion of isotonic fluid for treatment of significant hemorrhage is impractical because of the excessive time or pressure required to deliver the large volumes required for adequate volume expansion. Effective volume

expansion can be achieved with a 2-4 min. syringe-delivered small volume (4 ml/kg) of hypertonic saline dextran.

3. Initial evaluation of pathological effects of intraosseous infusion (published abstract A4)

In previous studies, we demonstrated equivalent cardiovascular responses to resuscitation of hemorrhaged sheep with 7.5% NaCl/6% dextran 70 (HSD) infused either IO or IV. However, the usefulness of intraosseous resuscitation would be limited by significant bone marrow pathology or pulmonary embolism from marrow tissue. Ten awake sheep were subjected to 2 hrs of hemorrhagic hypotension (arterial pressure - 50 mm Hg, bled volume - 1.2-1.8 liters), and then resuscitated with a 200 ml IO infusion (2-4 min) of HSD via bone marrow needle. Cardiovascular function was normalized one min after infusion. No sheep showed any deleterious effect from the infusion on either blood gases or respiratory rate. All sheep survived in apparent good health until euthanasia after 1-2 d (n=5); 2 wks (n=2); or 6 wks (n=3). Histological examination of sternums showed that the bony trabeculae and marrow fat remained intact, but hemopoietic cells exhibited a focal washout in the vicinity of the infusion site at 1-2 d post infusion. Specimens from the injection sites after 2-6 wks show replacement of hypocellular areas with fibrous tissue. In all cases, these changes were confined to the injection sites and in no case were they greater than 0.6 cm in diameter. No functional or histological evidence for pulmonary embolism was found.

4. Prototype intraosseous infusion device (published abstract A5)

We have produced 10 prototype intraosseous infusion devices for trials in sheep, pig and human cadavers. Two prototypes have been delivered to the Letterman Army Institute of Research for their experimental evaluation. Engineering design principles were applied to the problem of delivering low volume, concentrated saline/dextran solutions into red bone marrow for field treatment of hypovolemic shock. Special consideration was given to the field environment, the need for speed and safety, and the range of normal anatomic variation. This led to the development of a device (figure 2) that installs onto the midline of the manubrium or sternal body and delivers fluid into the marrow circulation. Automatic adjustment for variations in tissue and bone thickness is incorporated into the device. Minimal training appears necessary to properly use the device. An experienced technician can install the device and begin infusion in less than 30 seconds utilizing easily palpable landmarks. Design refinements have been based on prototype testing in human cadavers and anesthetized sheep.

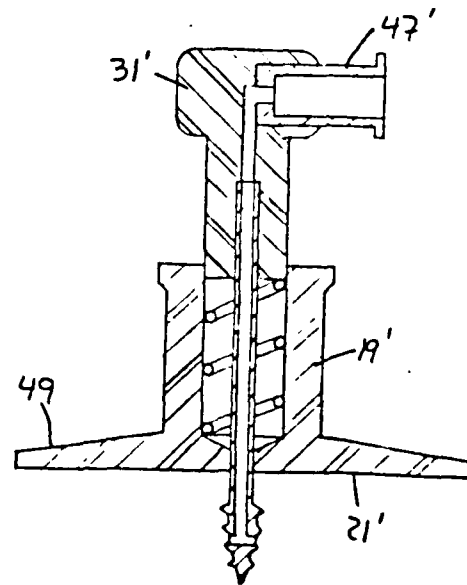

Figure 2.

REFERENCES

1. Nakayama, S, Sibley L, Gunther RA, Holcroft JW, Kramer GC: Small volume resuscitation with hypertonic saline (2400 mosm/l) during hemorrhagic shock. *Circulatory Shock* 13:149-159, 1984
2. Kramer, GC, Nakayama S, Smith GJ, Perron PR, Gunther RA, Holcroft JW: Comparison of hypertonic and isotonic saline resuscitation of hemorrhagic hypotension (Abstract) *Circulatory Shock* 13:61, 1984
3. Nakayama, S, Kamer, GC, Carlsen RC, Holcroft JW: Infusion of very hypertonic saline to bled rats: membrane potentials and fluid shifts. *J Surg Res* 38:180-186, 1985
4. Smith, GJ, Kramer GC, Perron P, Nakayama S, Gunther RA, Holcroft JW: A comparison of several hypertonic solutions for resuscitation of bled sheep: *J Surg Res* 39:517-528, 1985
5. Velasco, IT, Pontieri V, Rocha e Silva, Jr, M, Lopes OV: Hypertonic NaCl and severe hemorrhagic shock. *Am J Physiol* 239:H664-H673, 1980
6. Lopez, OV, Pontiere V, Rochae e Silva, Jr, M, Velasco IT: Hyperosmotic NaCl and severe hemorrhagic shock: role of the innervated lung. *Am J Physiol* 241:H883-H890, 1981
7. Traverso, LW, Bellamy RF, Hollenbach SJ, Witcher LD: Hypertonic sodium chloride solutions: Effect on hemodynamics and survival after hemorrhage in swine. *J Trauma* 27:32-39, 1987
8. Maningas, PA et al.: Small volume infusion of 7.5% NaCl-6% dextran 70 for the treatment of hemorrhagic shock. *Ann Emerg Med* 15:1131-1137, 1986

List of Publications

Supported by DAMD 17-88-C-8127

Manuscripts:

- M1. Kramer, G.C., J.C. Walsh, P.R. Perron, R.A. Gunther, S. Mertens, J.W. Holcroft, and F.W. Blaisdell. Resuscitation of hemorrhage with intraosseous infusion of hypertonic saline dextran. *Brazilian Journal of Medical and Biological Research* 22:283-286, 1989.

Abstracts:

- A1. Kramer, G.C., J.C. Walsh, P.R. Perron, R.A. Gunther, S. Mertens, J.W. Holcroft and W.F. Blaisdell. Resuscitation of hemorrhage with intraosseous infusion of hypertonic saline dextran. *FASEB Journal* 2:A974, 1988.
- A2. Perron, P.R., R.A. Gunther and G.C. Kramer. Pressure-flow relationships of intraosseous infusions. *Circulatory Shock* 24:282, 1988.
- A3. Saavedra, J., H.A. Patterson and G.C. Kramer. Intraosseous injection of hypertonic saline dextran: Anatomic considerations in man and sheep. *Circulatory Shock* 24:283, 1988.
- A4. Kramer, G.C., S.C. Mertens, L. Halvorsen, J.W. Holcroft, P.R. Perron and R.A. Gunther. Intraosseous infusion of hypertonic saline dextran: effects on pulmonary function and the histology of bone marrow. *Circulatory Shock* 27:348, 1989.
- A5. Bay, B.K., J.M. Henderson, F.W. Blaisdell, and G.C. Kramer. A device for rapid vascular access to the sternal marrow spaces for delivery of resuscitation fluids. *Circulatory Shock* 27:344-345, 1989.