

AD-A217 920

NPS61-89-011CR

NAVAL POSTGRADUATE SCHOOL

Monterey, California

DTIC
ELECTE
FEB 07 1990
S D
D



MODIFICATION, TESTING, AND CALIBRATION OF
INFRARED SEARCH AND TARGET DESIGNATOR
HARDWARE RECEIVED FROM NSWC

E. C. Crittenden, Jr.
Research Contractor
1176 Castro Rd., Monterey, CA

and
A. W. Cooper
Naval Postgraduate School

May 1989

Final Report for Period May 1986 to Feb. 1988

Approved for public release; distribution unlimited.

Prepared for:
Naval Postgraduate School
Monterey, CA 93943

90 02 06 126

NAVAL POSTGRADUATE SCHOOL
Monterey, CA, 93943

Rear Admiral R. C. Austin

Harrison Shull
Provost

May 9, 1989

This report includes work carried out for the Naval Postgraduate School by Eugene C. Crittenden, Jr. under N62271-7183-4768 and N62271-6059-7873, under Contract N62271-87-M-0205 and N62271-86-M-0213. The work was part of a program entitled "NACIT Infrared Search and Target Designator Research", funded in part by NAVSEA PMS 421 and under the cognizance of A. W. Cooper.

This report was prepared by:

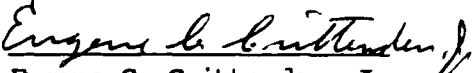
Eugene C. Crittenden, Jr.
1176 Castro Rd.
Monterey, CA, 93940

Publication of the report does not constitute approval of the sponsor for findings or conclusions. It is published for information and for the exchange and stimulation of ideas.

Reviewed by:

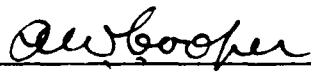
A. W. Cooper
Principal Investigator

K. E. Woehler
Chairman, Dept. of Physics

Released by:

G. E. Schacher
Dean of Science and Engineering

REPORT DOCUMENTATION PAGE

| | | | | | |
|---|-------|--|--|--|-----------------------------|
| 1a. REPORT SECURITY CLASSIFICATION UNCLASSIFIED | | | 1b. RESTRICTIVE MARKINGS | | |
| 2a. SECURITY CLASSIFICATION AUTHORITY | | | 3. DISTRIBUTION/AVAILABILITY OF REPORT Approved for public release; distribution unlimited | | |
| 2b. DECLASSIFICATION/DOWNGRADING SCHEDULE | | | | | |
| 4. PERFORMING ORGANIZATION REPORT NUMBER(S) NPS61-89-011CR | | | 5. MONITORING ORGANIZATION REPORT NUMBER(S) | | |
| 6a. NAME OF PERFORMING ORGANIZATION NAVAL POSTGRADUATE SCHOOL | | 6b. OFFICE SYMBOL (if applicable) Dept 61 | 7a. NAME OF MONITORING ORGANIZATION | | |
| 6c. ADDRESS (City, State, and ZIP Code) Monterey, CA 93943-5000 | | | 7b. ADDRESS (City, State, and ZIP Code) | | |
| 8a. NAME OF FUNDING/SPONSORING ORGANIZATION Naval Sea Systems Command | | 8b. OFFICE SYMBOL (if applicable) PMS-421 | 9. PROCUREMENT INSTRUMENT IDENTIFICATION NUMBER | | |
| 8c. ADDRESS (City, State, and ZIP Code) Washington, DC 20362-5101 | | | 10. SOURCE OF FUNDING NUMBERS | | |
| | | | PROGRAM ELEMENT NO. | PROJECT NO. | TASK NO. |
| | | | | | WORK UNIT ACCESSION NO. |
| 11. TITLE (Include Security Classification) TESTING AND CALIBRATION OF INFRARED SEARCH AND TARGET DESIGNATOR HARDWARE RECEIVED FROM NSWC (U) | | | | | |
| 12. PERSONAL AUTHOR(S) E.C. Crittenden, Jr. and A.W. Cooper | | | | | |
| 13a. TYPE OF REPORT Final | | 13b. TIME COVERED FROM 1986 TO 1988 | | 14. DATE OF REPORT (Year, Month, Day) 1989 May | 15. PAGE COUNT 28 |
| 16. SUPPLEMENTARY NOTATION | | | | | |
| 17. COSATI CODES | | | 18. SUBJECT TERMS (Continue on reverse if necessary and identify by block number) | | |
| FIELD | GROUP | SUB-GROUP | Infrared Search and Track Systems, Solutions to Cooling Problems | | |
| | | | | | |
| | | | | | |
| 19. ABSTRACT (Continue on reverse if necessary and identify by block number) <p>An Infrared Search and Track (IRST) system received at the Naval Postgraduate School, was inoperative on receipt because of failure of the cooling engine and detector Dewar flask thermal insulation. This system has now been converted to liquid nitrogen cooling with foam thermal insulation and has been successfully operated with the scanning head rotating. All surfaces are now temperature controlled and the system is provided with automatic controls to prevent thermal runaway during cool-down or warm-up. The present system eliminates the inner germanium window of the former Dewar flask. Besides simplifying the structure, this permits imaging closer objects than was previously possible. The optics of the Schmidt telescope imaging system have been tested with a collimating system, and by imaging of real objects at finite distances. A system has been provided for relative calibration and identification of the position of the 180 individual detector elements, and the relative response of each element measured at the detector and at the output of its preamplifier. Signals obtained from a heated Calrod source and from clouds and the surrounding terrain have been recorded with the optical system rotating.</p> | | | | | |
| 20. DISTRIBUTION/AVAILABILITY OF ABSTRACT <input checked="" type="checkbox"/> UNCLASSIFIED/UNLIMITED <input type="checkbox"/> SAME AS RPT. <input type="checkbox"/> DTIC USERS | | | 21. ABSTRACT SECURITY CLASSIFICATION UNCLASSIFIED | | |
| 22a. NAME OF RESPONSIBLE INDIVIDUAL A.W. Cooper | | | 22b. TELEPHONE (Include Area Code) (408) 646-2452 | 22c. OFFICE SYMBOL 61Cr | |

SUMMARY

The detecting system of the IRST, as received at the Naval Postgraduate School, was inoperative because of failure of the cooling engine and detector Dewar flask thermal insulation. This system has now been converted to liquid nitrogen cooling with foam thermal insulation and has been successfully operated with the scanning head rotating. All surfaces are now temperature controlled and the system is provided with automatic controls to prevent thermal runaway during cool-down or warm-up. The present system eliminates the inner germanium window of the former Dewar flask. Besides simplifying the structure, this permits imaging closer objects than was previously possible. The optical system of the Schmidt telescope has been tested with a collimating system, and by imaging of real objects at finite distances. A system has been provided for relative calibration and identification of the position of the 180 individual detector elements, and the relative response of each element measured at the detector and at the output of its preamplifier. Signals obtained from a heated Calrod source and from clouds and the surrounding terrain have been recorded with the optical system rotating.

| | |
|---------------------|-------------------------------------|
| Accession For | |
| NTIS CRA&I | <input checked="" type="checkbox"/> |
| DTIC TAB | <input type="checkbox"/> |
| Unannounced | <input type="checkbox"/> |
| Justification _____ | |
| By _____ | |
| Distribution / | |
| Availability Codes | |
| Dist | Avail and/or Special |
| A-1 | |



TABLE OF CONTENTS

| | Page No. |
|----------------------------------|----------|
| SUMMARY | 1 |
| TABLE OF CONTENTS | 2 |
| LIST OF FIGURES | 3 |
| LIST OF TABLES | 4 |
| I. INTRODUCTION | 5 |
| II. COOLING SYSTEM | 5 |
| 1. Detector Region Insulation | 8 |
| 2. Detector Region Heaters | 9 |
| 3. Reservoir Region Heaters | 9 |
| III. HEATER OPERATION | 10 |
| 1. Start-up | 10 |
| 2. Gas Flow | 10 |
| 3. Cool-down and Warm-up | 15 |
| IV OPTICAL TESTS | 15 |
| 1. Focus | 17 |
| V. DETECTOR CALIBRATION | 19 |
| VI. DETECTOR CALIBRATION IN SITU | 21 |
| VII. SYSTEM TRIALS | 25 |
| VIII. CONCLUSION | 25 |
| IX. REFERENCES | 27 |
| X. DISTRIBUTION LIST | 28 |

LIST OF FIGURES

| | |
|---|----|
| 1. Basic Cooling system | 6 |
| 2. Detail of Two-Pass Heat Exchanger System | 7 |
| 3. Reservoir Heater Circuit Diagram | 11 |
| 4. Heater Circuits Inside Telescope | 12 |
| 5. Structure for External LN2 Filling | 13 |
| 6. Gas Flow Connections | 14 |
| 7. Optical Subassembly Diagram | 16 |
| 8. Collimator Diagram | 18 |
| 9. Defocussed Blur Spot with Shadow | 20 |
| 10. Scan Signal and Equivalent Visual Scene | 26 |

LIST OF TABLES

| | |
|--|----|
| I. Focus Positions | 19 |
| II. Relative Responsivity Results | 22 |
| III. List of Defective Detector Channels | 24 |

I. INTRODUCTION

The detecting system of the IRST, as received at the Naval Postgraduate School, had been previously cooled by means of a closed cycle cooling engine and the detectors thermally insulated by means of a Dewar flask. The flask had an inner and outer germanium window. This flask had failed because of thermal stresses in the inner window seals that occurred during cool-down and warm-up. Five such Dewar flasks had been built elsewhere and all had failed. The existing cooling engine, as received at NPS, had already operated beyond its predicted life and needed reworking. Cooling by means of liquid nitrogen with foam thermal insulation offered simplicity and low cost and seemed adequate for laboratory and field experimental work in a nonmilitary environment. Consequently the system was redesigned and rebuilt along those lines. The evaporating liquid nitrogen also provided dry gas to exclude moisture. The redesigned enclosure eliminated the inner germanium window, leading to an ability to focus the system for nearby objects as close as 10 meters. This permitted use of calibrating sources in reasonable space in the laboratory. Using both this capability and a collimating system, the relative response of each of the 180 individual detector elements was determined. Signals obtained from a heated Calrod source and from clouds and the surrounding terrain have been recorded with the optical system rotating.

II. COOLING SYSTEM

After considerable effort had been spent on unsuccessful attempts to repair the leaks in the one existing double-walled vacuum flask, that design was abandoned in favor of a design utilizing foam insulation. Experimental tests on a mock-up of the foam insulated design indicated that the detectors could be maintained at near liquid nitrogen temperature with a heat leakage load of approximately 15 watts. The structure for providing cooling to the detector region is shown in Figure 1. The handling of the efflux gas was later modified as shown in Figure 2. Basically, liquid nitrogen is held in a reservoir above the detector cooling well that is part of the IRST assembly. This well is a cylindrical chamber with one inch inside diameter and 6 inches long. The wall of the chamber is thin stainless steel. It is welded on the upper end to the 1/4 inch thick horizontal face plate which supports the detector structure. The plate is gasketed to the top surface of the outer wall of the telescope chamber. Since the upper end of the cooling well must be at telescope wall temperature, it is necessary to provide cooling to the lower end of the well without cooling the upper end of the well. This is accomplished by allowing the liquid nitrogen to flow into the cooling well through a thin walled stainless steel feed tube that reaches deep into the cooling well and is separated from the inner wall of the upper end of the cooling well by a thin layer of foam insulation. To prevent the liquid nitrogen from flowing out of the top of the cooling well, the feed tube was constructed to pass through a thin, .010 inch thick, web of stainless steel which was hard-

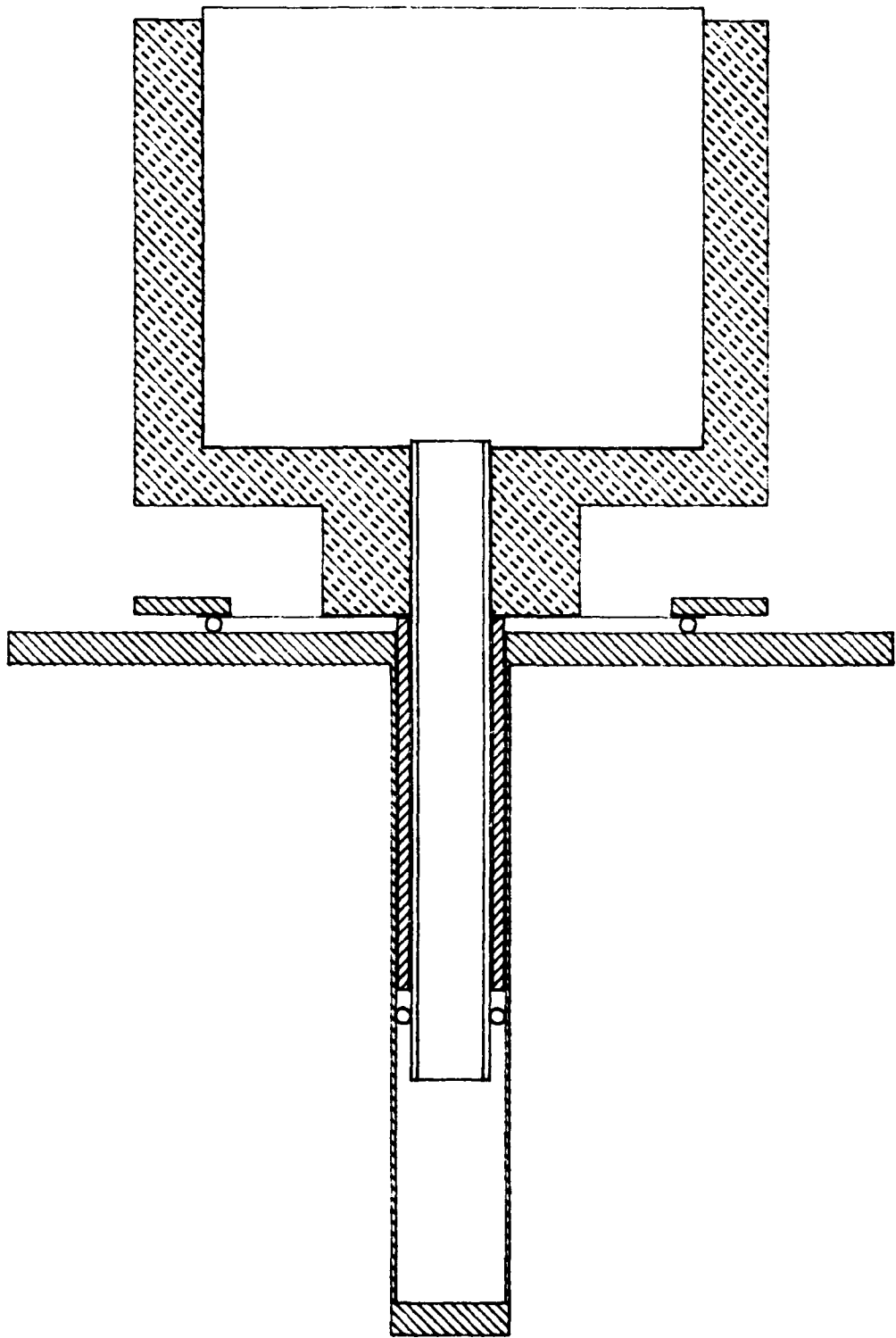

Fig. 1 Basic Cooling System

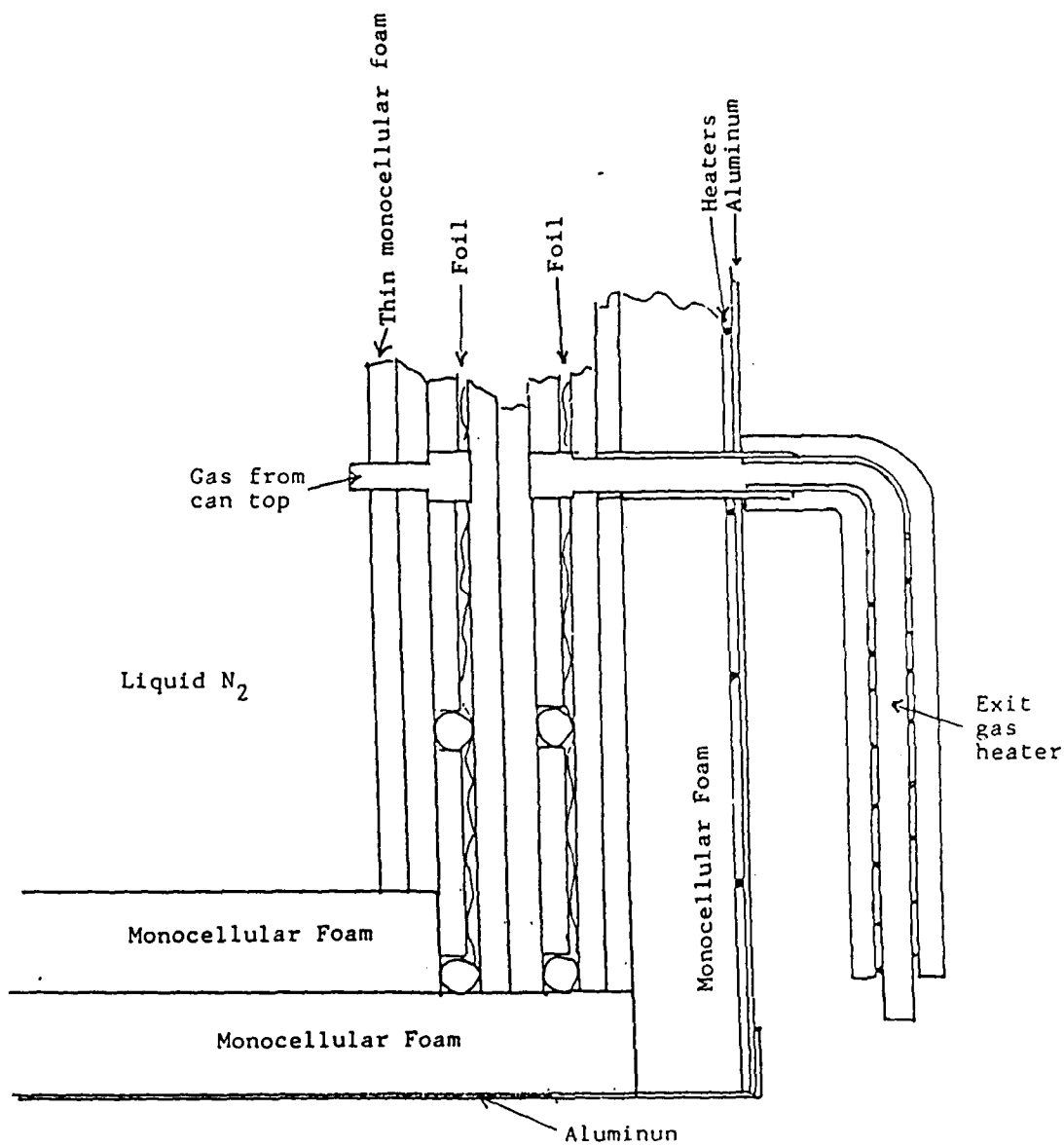

Fig. 2 Detail of Two-pass heat exchanger system

soldered to the feed tube. This web is sealed at its outer edge to the 1/4 inch thick horizontal face plate with an O-ring. This allows the sealing O-ring to remain at room temperature at the outer edge of the stainless steel web. The web is separated from the face plate by the thickness of the O-ring. During operation, the space between the web and the face plate is filled with gaseous nitrogen from the evaporation of the liquid nitrogen in the cooling well. Since this space is sealed relative to the region outside the nitrogen chamber, no liquid resides in this space. To improve the insulation in this gap, it is also filled with a layer of foam.

The inner diameter of the feed tube from the reservoir to the cooling well is large enough that liquid can flow down to the well freely and still allow the passage of bubbles of gaseous nitrogen rising from the cooled well walls. Tests of this system showed that the detectors are maintained at a temperature of 86 K during operation, as measured on the temperature indicator of the IRST control console.

The clearances available under the outer cover of the IRST rotating platform are small enough that only a one quart container could be used as a reservoir and leave adequate room for foam insulation of the reservoir. The most practical container for the reservoir was found to be a one quart paint can. This has a double seal that seats either on expansion or contraction of the can lid. A relatively tight seal, but not necessarily vacuum quality seal, is necessary in order to use the evaporated dry nitrogen as the flushing gas for the telescope and detector chamber. In the later modification the evaporating liquid nitrogen gas is used to dry the interior of the detector head and the telescope after heating to room temperature. The process of heating in the walls of the reservoir also increases the cooling capacity of the system and extends the hold time of the reservoir. The evaporating nitrogen is picked up at the top of the reservoir in two 1/4 inch copper tubing fittings. As shown in Figure 2, the gas is then led in plastic tubing down through the insulation in approximately four turns around the can in a layer at a distance one third of the way out through the insulation. The heat is spread in this layer with heavy aluminum foil. The tubing then makes an additional pass to the top of the insulation at a distance two thirds of the way out through the insulation. This two-pass heat exchanger takes advantage of the heat capacity of the gas while warming it for use as flushing gas. The hold-time of the reservoir is approximately doubled by the heat exchanger, and provides a hold-time of approximately one hour. The fill tube for the reservoir is so located as to permit a flexible one inch diameter plastic tube to project through the top of the outer external cover of the rotating platform for refilling the reservoir during protracted operation.

1. Detector Region Insulation

The space around the detectors is filled with foam insulation pieces cut from previously foamed samples. The material is largely monocellular foam. The space in front of the detectors is left free of foam. The exterior of

the foam insulation is cut to just fit within the previous outer wall of the Dewar flask originally used in the IRST. The original outer window is now the entrance window of the detector assembly. This now has one less window and the detector head position in the telescope has been moved to account for this, as will be described later. Each group of 90 detectors is separated from the window by its infrared filter, which serves as an additional layer for insulation from the window. Circulation of nitrogen via convection in the gaps between the detectors and the infrared filters and between the filters and the window is purposely inhibited by careful filling of the gaps at the edges of these regions with small pieces of foam.

2. Detector Region Heaters

The germanium infrared transmitting window and the exterior of the detector head would become cold if left unheated during operation. This would be likely to cause degradation of the resolution of the telescope because of thermal convection within the telescope. It would also run the additional risk of dew or frost formation on the infrared window, in the event of poor drying of the atmosphere within the telescope. Dew or frost formation on the head assembly within the telescope would also pose a problem to the system on warm up, if dripping were to occur. To avoid these problems, a heater is provided around the periphery of the infrared window, and a heated shield provided to cover the remainder of the detector head, to keep all these surfaces at telescope temperature. The heater for the window is a wire cemented into the channel originally used to take up differential expansion between the window and the Dewar flask wall. The heat shield for the remainder of the detector assembly is a blackened aluminum cylinder, heated by means of a heater wire wound around the outside of the foam insulation, just inside the aluminum heat shield. The window and heat shield heaters are connected in parallel and operate on 9.6 volts.

3. Reservoir Region Heaters

The parts of the system external to the telescope are also heated to prevent problems that would otherwise occur from the sweating of cold surfaces. Heaters for the external parts of the detector head are located in the mounting flange and gasket region and inside all the remaining external surfaces. The efflux gas used for flushing the detector head and the telescope interior is first warmed by circulation through the two-pass heat exchanger within the insulated walls of the reservoir and then heated further with two tubular external heaters. All of these heaters are matched to operate on 12.5 volts to reduce the number of power supplies required on the rotating head. All the heaters are operated from dc supplies that run from the 400 Hz power available on the rotating platform of the IRST. Use of DC heater supplies avoids possible AC pickup through the detectors that might be troublesome with low level signals.

III. HEATER OPERATION

The circuit diagram of the heaters is shown schematically in Figures 3 and 4. The heater elements are glass-wound Chromel or Alumel wires taken from Chromel-Alumel thermocouple pairs. The heaters are operated by dc power to avoid ac pickup in the sensitive circuits on the rotating head. The dc power supply is mounted on the rotating head to avoid the necessity for an additional set of slip ring leads. A thermal switch provides automatic control during warm-up. This allows the heater power to be left on for a period after the liquid nitrogen has been exhausted without the danger of the system being overheated if forgotten. The switch is a Curie temperature controlled magnetic switch, set to cut off at 25 C. It is mounted at the bottom of the detector head, inside the thermal shield and in the exhaust gas flow from the detector head into the telescope chamber. Because the rated current for this switch is rather small, it is connected through separate leads from the heaters, and arranged to cut off the primary ac power to the DC power supply for the heaters when the temperature exceeds 25 C.

1. Startup

To provide for filling of the liquid nitrogen reservoir with the upper metal cover of the rotating system in place, the filling tube was extended through the metal cover. It is indicated in Figure 5. The metal filling tube at the top of the reservoir is extended with a plastic tube fitting over the metal tube. The plastic tube extends through a 2 1/2 inch diameter hole cut in the metal cover. The plastic tube passes through a rubber stopper which fits tightly into the 2 1/2 inch hole in the metal cover, sealing against external water which might be flowing down the top in adverse weather. To improve the seal of the plastic tube where it passes through the rubber stopper, a stainless steel tube is inserted into the plastic tube, expanding the plastic tube against the inside of the hole through the rubber stopper. A rubber cork then seals the metal tube when filling is completed. This metal tube also assures roundness of the upper end of the filling tube which the cork must seal. Previous use of a plastic tube, without the metal insert to receive the sealing cork, led to leakage which could not then be sealed. The plastic tube tended to stiffen in a non-round condition during liquid nitrogen filling and the condition was perpetuated because of leakage of cold gas at that point.

2. Gas Flow

The gas flow in the system is arranged to provide flushing with dry gas in advance of cool-down. A diagram of the gas flow connections is shown in Figure 6. The flow during advance flushing, with external dry gas supplied at point A, is divided at the Y fitting at B. One branch carries dry gas to the detector head at C. In the detector head it divides again and one branch, D, flows from the middle of the detectors out the top vent in the head and back into the telescope chamber. The other branch in the head

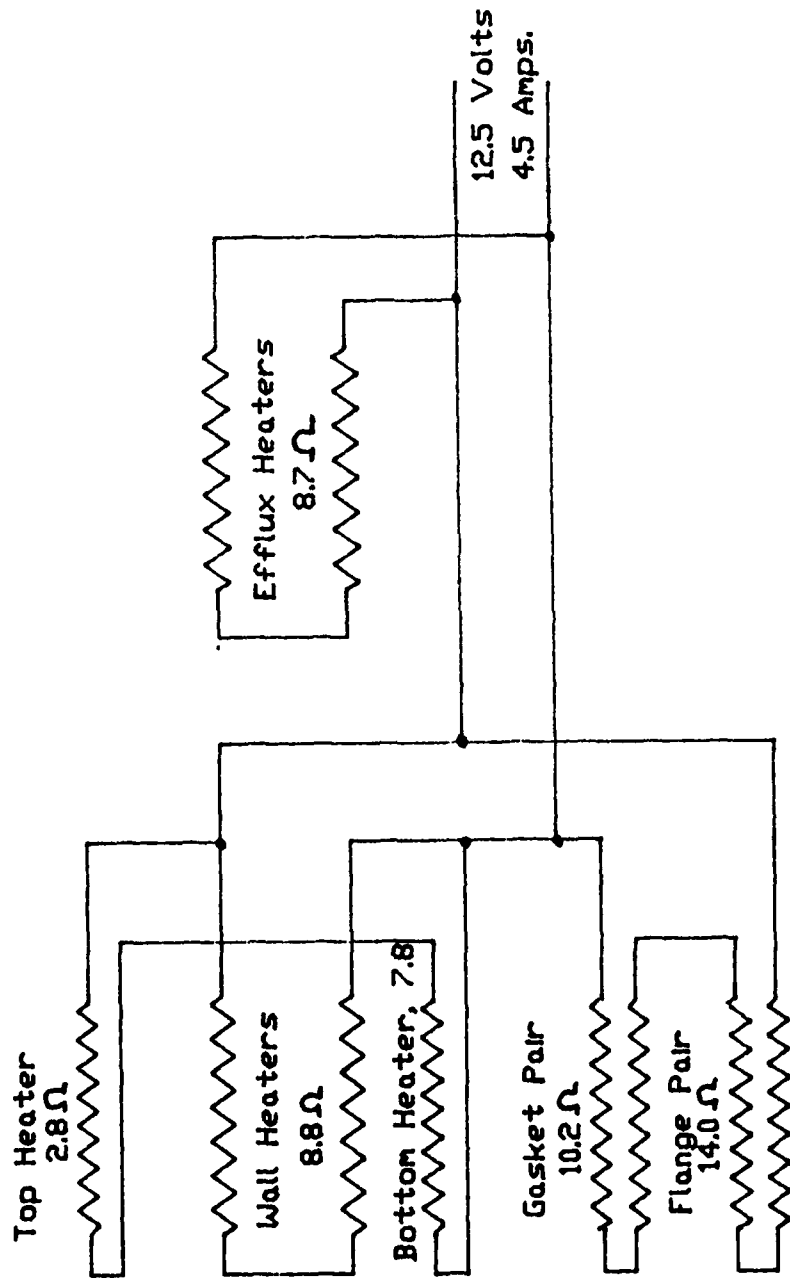

Fig. 3 Reservoir Heater Circuit Diagram

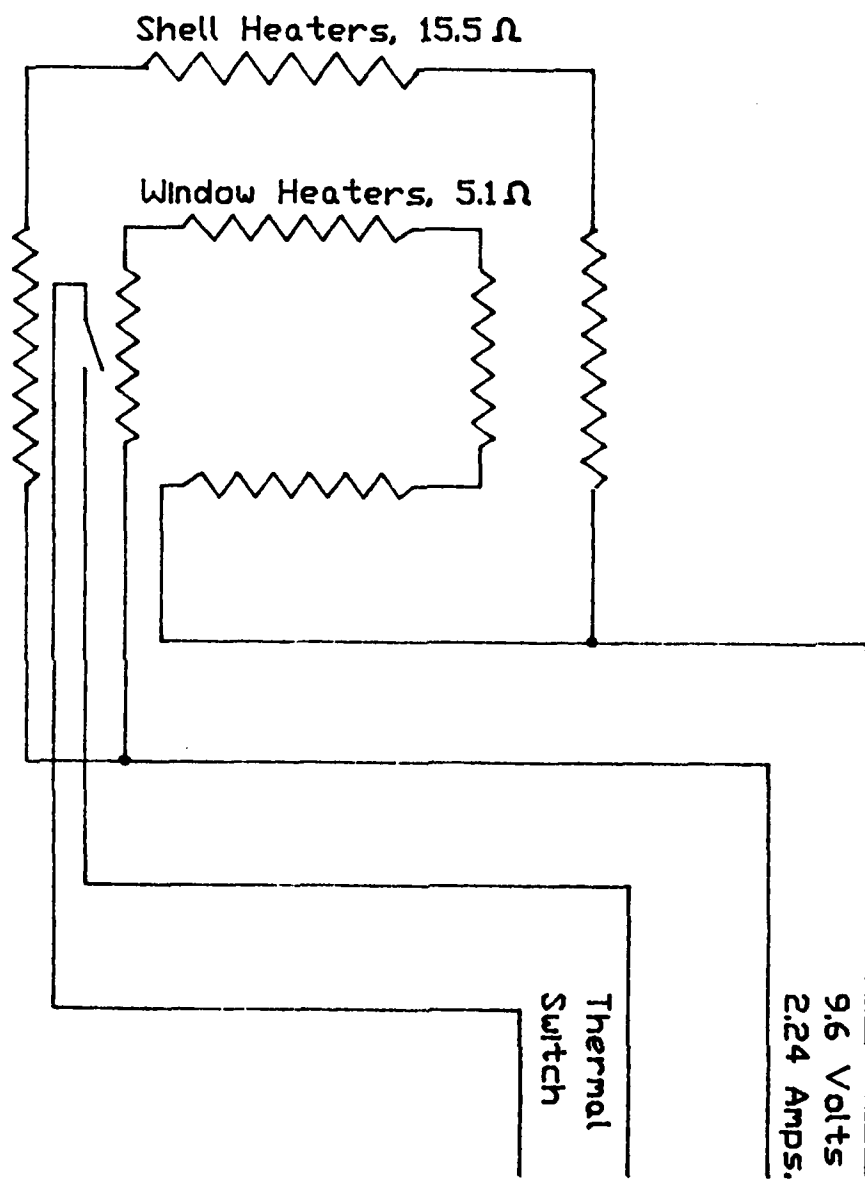

Fig. 4 Heater Circuits Inside Telescope

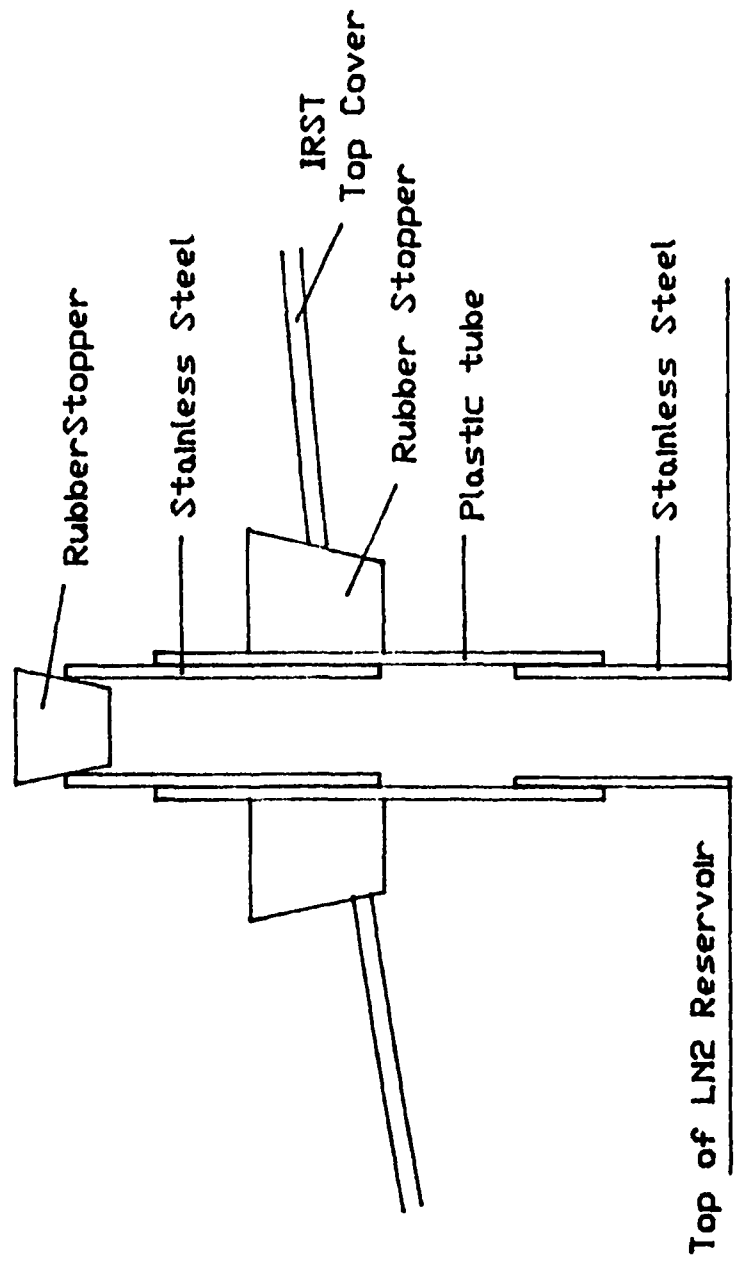

Fig. 5. Structure for External LN2 Filling

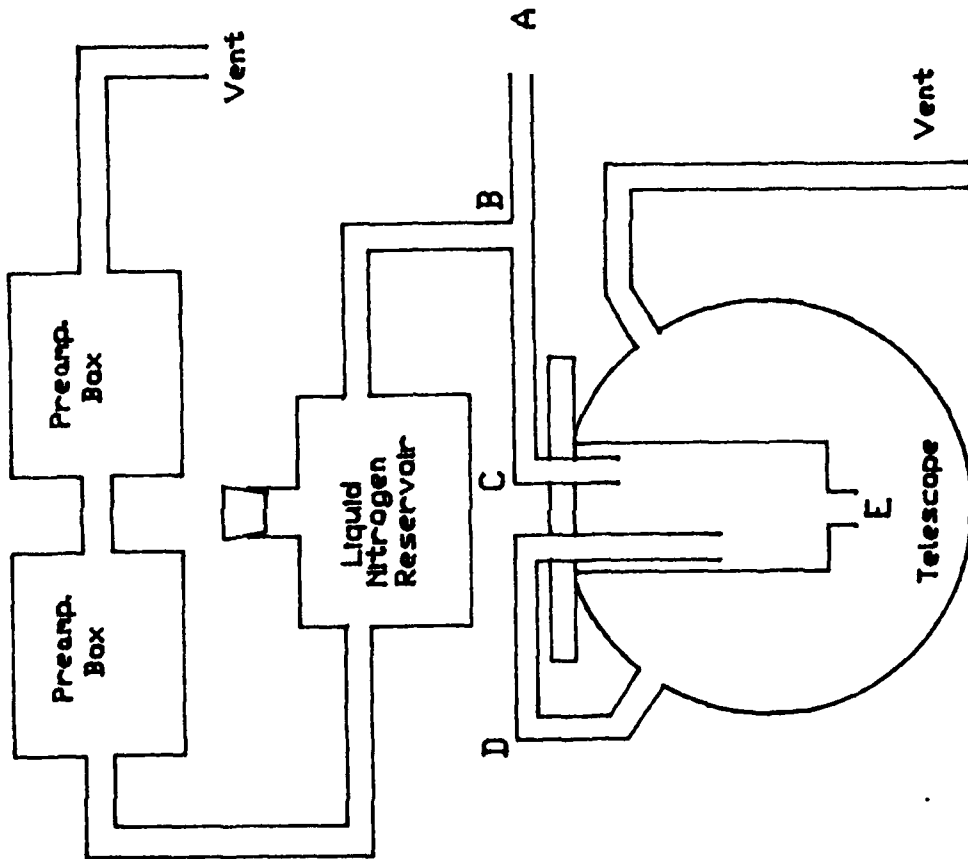

Fig. 6 Gas Flow Connections

flows out the bottom of the detector head into the telescope chamber at E. The telescope chamber is vented at F. This gas fitting is also used for the electrical leads into the telescope chamber and for the leads out from the thermal sensor. The gas flow out of the telescope chamber is vented to the atmosphere after passage through about 4 feet of tubing, to reduce back diffusion of water vapor when the system is not in use. The second branch at the Y at point B flows gas into the empty reservoir for liquid nitrogen. This is done to dry out any possible water left from ice falling into the reservoir during filling. The exit gas from the reservoir is then fed to the preamplifier boxes and finally vented to the atmosphere with a tubing length of about 4 ft.

After flushing the system for about one hour the inlet fitting is plugged and the liquid nitrogen reservoir filled. When the filling tube is plugged, the evolving gas then flows through two paths in parallel. One path passes through the two preamplifier chambers and the other passes through the detector head and the telescope chamber. No valve switching is required to change from advance flushing to normal operation, other than disconnecting the external flushing supply and plugging the external opening.

3. Cool-down and warm-up

In normal operation the reservoir is filled through the tube protruding through the top metal cover of the IRST. A long tube funnel is desirable. It should have a tube diameter small enough to allow escaping gas to vent freely. A paper clip or wire to lift the conical part of the funnel slightly above the fill tube entrance helps let the gas vent freely. Since the internal parts are initially warm, a second filling is ordinarily needed before start-up.

The cool-down time to equilibrium at 86-87 K is 12 minutes. The second filling would ordinarily be done at this time. The hold time at an operating temperature of 86-87 K is then one hour. By contrast, the former expansion engine system reached that temperature in 50 minutes and full equilibrium at 80 K in 73 minutes.

The system has been operated with the IRST head rotating, with no apparent problems with the cooling system.

IV. OPTICAL TESTS

The optical system is shown schematically in Figure 7. The original system had two germanium windows in front of the detectors, as part of the double-walled Dewar flask used for thermal insulation. Replacement of the Dewar flask with foam insulation led to removal of the previous inner window. This had the effect of displacing the focal point for an infinite object to a point about 4 mm closer to the spherical mirror. This is just within the range of position adjustment of the detector assembly. The optimum focus

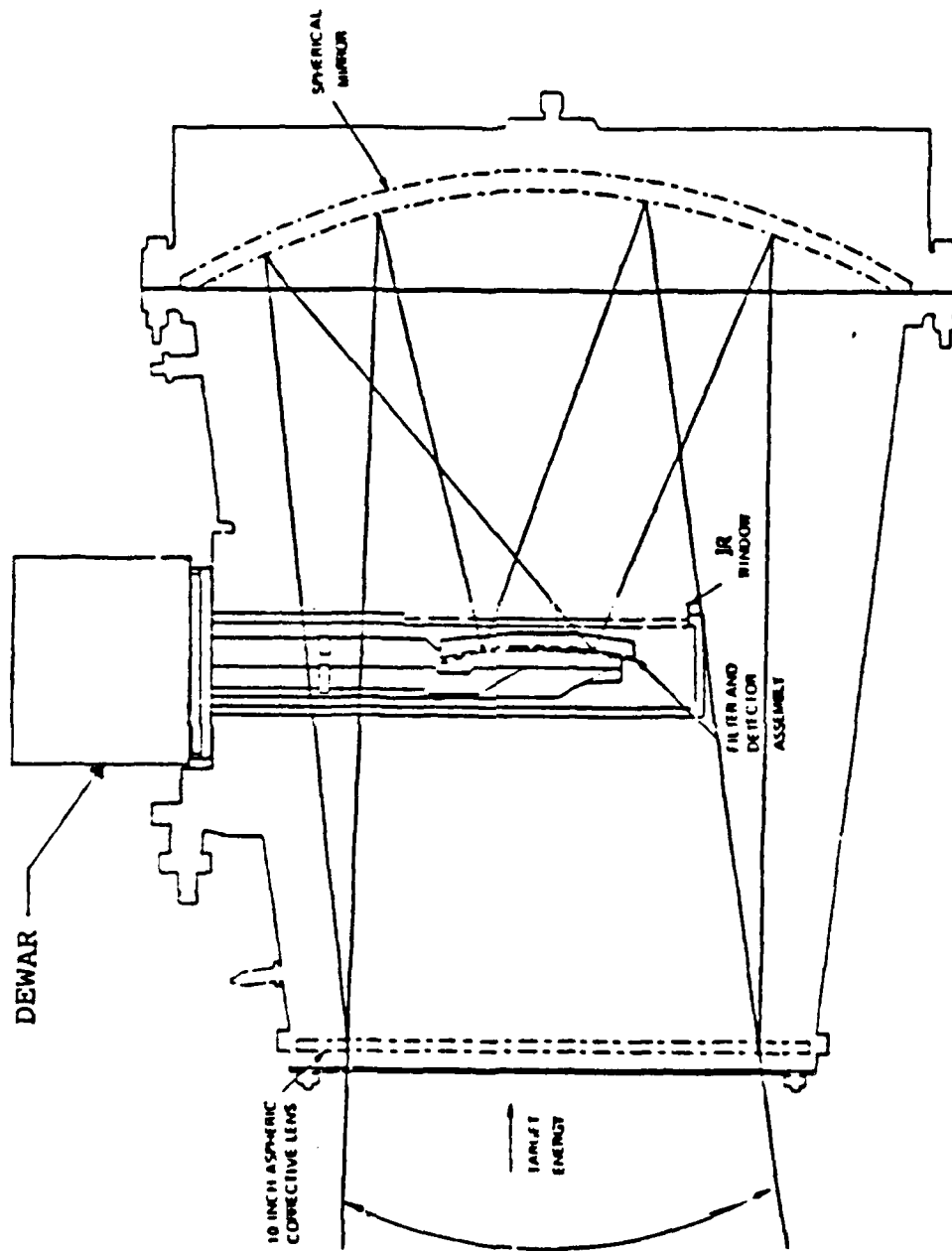

Figure 7. Optical Subassembly Diagram

position for an infinitely distant object is now located at a point 1.0 mm back (toward the input Schmidt plate) from the farthest possible point of travel of the head toward the mirror.

1. Focus

The focus position was determined by use of the collimating system provided with the IRST equipment. The collimating equipment had been designed to be used with the collimator axis vertical and with a turning mirror at the output to deflect the light along the approximately horizontal axis of the Schmidt telescope. The turning mirror proved to be badly tarnished and also added an unnecessary surface at which lack of flatness could disturb the results. Additionally, precision determination of the angle of deflection by the mirror promised to be difficult. To avoid these problems, the collimator was supported immediately in front of the Schmidt telescope. Its angle from the horizontal was adjusted by lifting the rear end on laboratory jacks. A diagram of the collimator is shown in Figure 8.

Since the collimator optics are entirely reflective, there is no chromatic aberration. It is thus possible to adjust that system using visible light and have it in correct adjustment for infrared. The adjustment to produce parallel light was done with a Gauss eyepiece system. The pinhole source used for infrared was replaced with a crosshair. This was illuminated by means of light reflected from a 45 degree glass plate behind the crosshair, so as to project light into the collimator in the general direction of its axis, through the crosshair as a source. An optically flat mirror was then placed at the output aperture of the collimator, so as to reflect light directly back along the axis. This produced an image of the crosshair on the source crosshair. The adjustment of the collimator to produce parallel light consisted of moving the plane of the source crosshair until the crosshair image lay exactly in the same plane. This was tested by means of parallax, i.e. the relative lateral motion of the source and image when the eye is moved perpendicular to the collimator axis. Proper positioning of the source plane is indicated by no relative motion. The crosshair was then replaced by the pinhole defining the infrared source position, with the plane of the pinhole located exactly in the previous plane of the crosshair.

For detection of infrared, the source was chopped by means of the chopper wheel indicated in Figure 8. The wheel produced equal time on and time off, and was run at a speed for these measurements which produced a repetition rate of about one kilohertz. With the detector head cooled, the infrared signal for any given detector was observed on an oscilloscope. Rocking the entire IRST rotating assembly through a small angle about the vertical axis allowed locating the angular position of the assembly for maximum signal. The variation with head position, of the signal on adjoining detectors relative to that for a given detector, was used to locate the best focus position. In the best position, zero signal was observed on adjoining detectors. The same test was made in the center of the field and

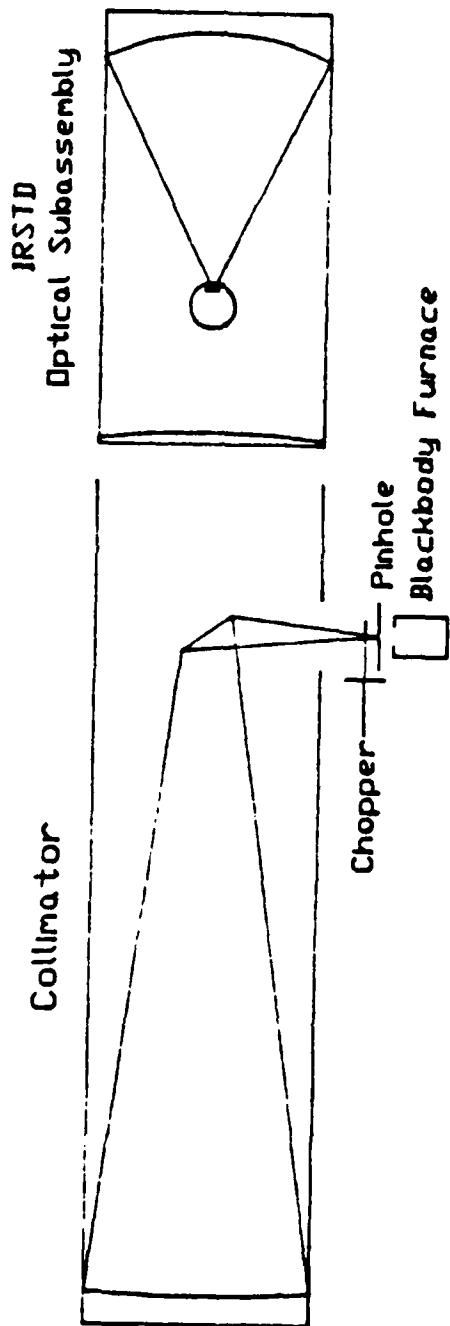

Figure 8. Collimator Diagram

at the extremes. As the same head position applied in all cases, the curvature of the detector surface appears to be correct.

The proper position of the detector head as a function of object distance can be readily calculated using the Newton form of the first order lens (or mirror) equation, as follows:

$$X X' = f^2$$

Where: X is the distance of the object from the focal point,
 X' is the distance of the image from the focal point,
 f is the focal length, in this case 10 inches = 254 mm.

So: $X' = \frac{64516}{X}$ in mm, with X in mm; yielding values below.

TABLE I. FOCUS POSITIONS

| X in m. | X' in mm. |
|---------|-----------|
| 10 | 6.45 |
| 20 | 3.23 |
| 30 | 2.15 |
| 40 | 1.61 |
| 50 | 1.29 |
| 75 | .86 |
| 100 | .65 |
| 150 | .43 |
| 200 | .32 |
| 400 | .15 |
| 1000 | .06 |

The displacement of the image, X', is in the direction away from the mirror. The focal position for an infinitely distant object is 1.0 mm from the farthest possible point of travel toward the mirror. (Edge of the detector head mounting plate pressed against the shoulder on the telescope chamber which limits the motion.)

V. DETECTOR CALIBRATION

The collimator system described above was used to measure the relative response of each detector through its associated preamplifier. The collimator was defocused so as to produce a broad uniform spot in order to illuminate the complete sensitive area of each detector. The pattern produced by the collimator is shown in Figure 9. The keyhole-like pattern is the result of the shadow of the detector head. Each detector was located

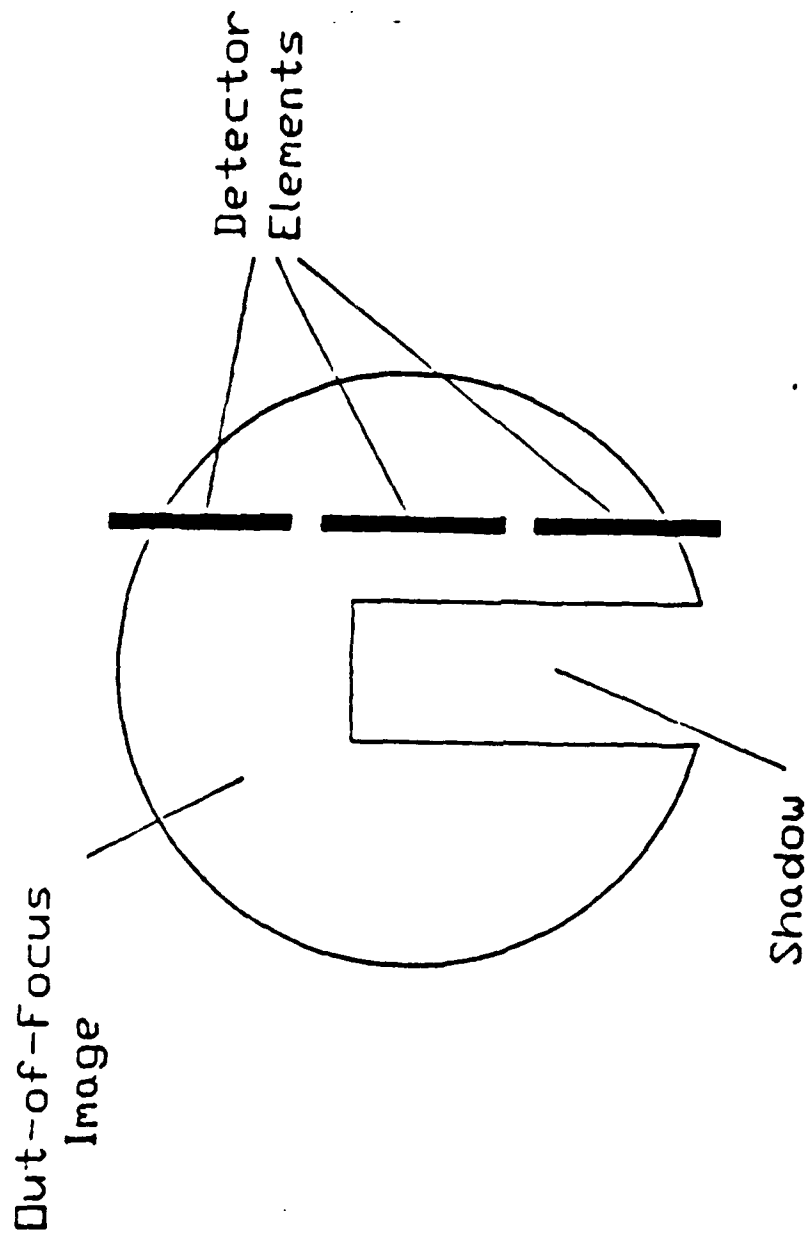

Figure 9. Defocused Blur Spot With Shadow

in the center of one side of the pattern for its individual test, as indicated in Figure 9.

The source for the collimator was a pinhole in front of a blackbody furnace at 500 ± 3 C. The pinhole had a diameter of 2.56 ± 0.01 mm. Because of uncertainties in the effects of defocussing, mirror tarnish, and amplifier gain, it is not possible to calculate the absolute responsivity of the detectors. However the relative magnitudes of the signals are valid.

The chopper speed was changed for these measurement from the speed used for focus testing. The speed used here was chosen to match the detector pulse width that would be produced for passage of a point source across a given detector during rotation of the IRST head at 30 RPM. The chopper wheel speed chosen produced a pulse repetition rate of 5.2 kilohertz.

The signal waveform from each detector, as observed through its preamplifier, was recorded on a model 3091 Nicolet digital oscilloscope. The waveform, stored in 4000 data points, was then recorded on hard disk in a Compaq portable II computer. The magnitude of the signal was later averaged in the Masscomp computer.

The relative response of the individual detectors is reported in Table II. Detectors 101 to 190 are detector elements of the lead array and detectors 201 to 290 are detector elements of the lag array. The larger response values for the lag array than for the lead array is the result of differing IR band filters mounted in front of each detector bank. Some of the detectors showed substantially lower response than most of the detectors. These are marked with a star in Table II. The defective detector channels are also listed separately in Table III. Further details are given in an NPS Master's Thesis by Gary R. Ayers.¹

VI. DETECTOR CALIBRATION IN SITU

Identification of the position of individual detectors and calibration of the relative response of each can be obtained with the IRST system installed on the 8th floor by installing the Calrod source at a distance of about 10 meters, with the optics adjusted for this distance. Such a test is needed because the cable connections to bring the signals to room 703 or 221 may interchange some detector leads. Additionally, any buffer amplifiers or digitizers involved in transmission of the signals to the lower floors may change the relative gain. With the long direction of the Calrod horizontal, a single detector will be illuminated. Mounting the source on a structure 1.6 meters (5.3 ft.) above the telescope level will reach the upper limit of the field of view. Motion of the source vertically will then identify the sequence of detector positions.

TABLE II
RELATIVE RESPONSIVITY RESULTS

| <u>Side 1</u> | <u>Amplitude (volts)</u> | | <u>Side 2</u> | <u>Amplitude (volts)</u> |
|---------------|--------------------------|---|---------------|--------------------------|
| 101 | 1.522 | * | 201 | 0.020 |
| 102 | 1.350 | | 202 | 3.433 |
| 103 | 1.580 | | 203 | 3.382 |
| 104 | 1.904 | | 204 | 3.189 |
| 105 | 1.900 | | 205 | 3.512 |
| 106 | 1.747 | | 206 | 3.400 |
| 107 | 1.681 | | 207 | 3.261 |
| * 108 | 0.071 | | 208 | 3.321 |
| 109 | 1.651 | | 209 | 3.302 |
| 110 | 1.622 | | 210 | 3.163 |
| 111 | 1.762 | | 211 | 3.132 |
| 112 | 1.631 | | 212 | 3.320 |
| 113 | 1.583 | | 213 | 3.251 |
| 114 | 1.790 | | 214 | 3.189 |
| * 115 | 0.400 | | 215 | 3.180 |
| 116 | 1.751 | | 216 | 3.166 |
| 117 | 1.838 | | 217 | 3.262 |
| 118 | 1.782 | | 218 | 3.305 |
| 119 | 1.702 | | 219 | 3.391 |
| 120 | 1.691 | | 220 | 3.119 |
| 121 | 1.750 | | 221 | 2.802 |
| 122 | 1.763 | | 222 | 3.028 |
| 123 | 1.612 | | 223 | 3.202 |
| 124 | 1.791 | | 224 | 3.270 |
| 125 | 1.643 | | 225 | 3.140 |
| 126 | 1.592 | * | 226 | 0.020 |
| 127 | 1.642 | * | 227 | 0.022 |
| 128 | 1.661 | * | 228 | 0.600 |
| 129 | 1.581 | * | 229 | 0.600 |
| * 130 | 0.050 | * | 230 | 0.030 |
| 131 | 1.611 | * | 231 | 3.050 |
| 132 | 1.692 | | 232 | 2.475 |
| 133 | 1.702 | | 233 | 3.050 |
| 134 | 1.722 | | 234 | 3.000 |
| 135 | 1.800 | | 235 | 3.322 |
| 136 | 1.830 | | 236 | 3.120 |
| 137 | 1.650 | | 237 | 3.122 |
| 138 | 1.381 | | 238 | 3.030 |

* Denotes that the detector channel's response is irregular.

TABLE II
(Cont)

| | | | |
|-------|-------|-------|-------|
| 139 | 1.680 | 239 | 3.150 |
| 140 | 1.740 | 240 | 3.361 |
| 141 | 1.604 | 241 | 3.281 |
| 142 | 1.730 | 242 | 3.410 |
| 143 | 1.756 | 243 | 3.450 |
| 144 | 1.712 | 244 | 3.452 |
| 145 | 1.693 | 245 | 3.404 |
| 146 | 1.831 | 246 | 3.303 |
| 147 | 1.840 | 247 | 3.233 |
| 148 | 1.811 | 248 | 3.261 |
| 149 | 1.811 | 249 | 3.383 |
| * 150 | 0.030 | * 250 | 1.183 |
| 151 | 1.665 | 251 | 3.291 |
| 152 | 1.699 | 252 | 3.268 |
| 153 | 1.794 | 253 | 3.113 |
| 154 | 1.835 | 254 | 3.201 |
| 155 | 1.791 | 255 | 3.242 |
| 156 | 1.712 | 256 | 3.144 |
| 157 | 1.729 | 257 | 3.109 |
| 158 | 1.702 | 258 | 3.280 |
| 159 | 1.791 | 259 | 3.131 |
| 160 | 1.729 | 260 | 3.231 |
| 161 | 1.690 | 261 | 3.058 |
| 162 | 1.679 | 262 | 2.911 |
| 163 | 1.673 | 263 | 3.102 |
| 164 | 1.790 | 264 | 3.055 |
| 165 | 1.742 | 265 | 3.141 |
| 166 | 1.819 | 266 | 3.031 |
| 167 | 1.668 | 267 | 3.101 |
| 168 | 1.733 | 268 | 3.149 |
| 169 | 1.820 | 269 | 3.267 |
| 170 | 1.720 | 270 | 3.110 |
| 171 | 1.770 | * 271 | 0.015 |
| 172 | 1.592 | 272 | 3.340 |
| 173 | 1.824 | 273 | 3.299 |
| 174 | 1.833 | 274 | 3.219 |
| * 175 | 0.035 | 275 | 3.160 |
| * 176 | 0.030 | 276 | 3.042 |
| 177 | 1.829 | 277 | 3.164 |
| * 178 | 0.030 | * 278 | 2.613 |
| 179 | 1.902 | * 279 | 2.580 |
| 180 | 1.870 | * 280 | 2.480 |
| 181 | 1.876 | 281 | 3.142 |
| 182 | 1.854 | 282 | 2.970 |
| 183 | 1.704 | 283 | 2.882 |
| 184 | 1.621 | 284 | 3.082 |
| 185 | 1.711 | 285 | 3.213 |
| 186 | 1.751 | 286 | 3.330 |
| 187 | 1.662 | 287 | 3.161 |
| 188 | 1.662 | 288 | 2.952 |
| 189 | 1.640 | 289 | 2.840 |
| 190 | 1.681 | 290 | 2.919 |

* Denotes that the detector channel's response is irregular.

TABLE III
LIST OF DEFECTIVE DETECTOR CHANNELS

| <u>Lag Array</u> | <u>Lead Array</u> |
|------------------|-------------------|
| 01 | 08 |
| 26 | 15 |
| 27 | 30 |
| 28 | 50 |
| 29 | 75 |
| 30 | 76 |
| 50 | 78 |
| 71 | |
| * 78 | |
| * 79 | |
| * 80 | |

* Denotes that detector is operational but signal strength is significantly diminished.

VII. SYSTEM TRIALS

The system was tested in operating configuration with the head rotating at 30 RPM, except that only a few channels at a time could be brought out through the slip rings at that time. An additional trigger signal giving one pulse per head revolution was also added by means of interruption of a small LED-photocell path by a small metal flag attached to the rotating head. This allowed triggering the oscilloscope once per revolution to view the detector signals.

Two types of tests were carried out. The first employed a heated Calrod as a source, at a distance of 20 meters. The focus point for the IRST optics was adjusted for this range. Other targets in the surrounding region were masked out with a screen of polyurethane foam at room temperature. This reduced the clutter due to surrounding warm objects, including the operating personnel. The signal due to the Calrod source could be easily identified in this situation. A sharp peak was observed. The sharpness of this peak allowed precision adjustment of the focus position. The second test was carried out with the IRST looking out of the door of the laboratory on the roof of Spanagel Hall toward a distant scene, with the focus readjusted for infinity. Two traces could be observed and digitally recorded on the oscilloscope. To give representative traces, one detector was chosen to scan at the horizontal level, and another detector chosen to scan at cloud level. The system performed properly. An IR trace and the equivalent visual scene are shown in Figure 10. The proper signal direction is negative in that trace. The positive signal following each large negative signal is overshoot due to preamplifier saturation. The target marked as A is a pipe protruding from the deck railing. B is the end of the eighth floor on the South end of Spanagel hall. This surface is perpendicular to the sunlight at that time and the corner viewed is quite warm. C is an edge view of the line of posts supporting the roof of the ground plane on the shack in the center of the 7th deck. D is the stairway to the top of the ground plane on the same shack.

VIII. CONCLUSION

The detector head has been modified to use liquid nitrogen cooling, with heated surfaces to prevent temperature gradients within the telescope. The controls have been provided with interlocks to provide fail-safe operation on cool-down and warm-up, and the system has been adapted for operation during rotation of the IRST head. The detectors and preamplifiers have been calibrated, and precision location of the head for focus has been determined. A system has been provided for in situ calibration. The complete system has been successfully tested in full operation during rotation scanning of the IRST head.

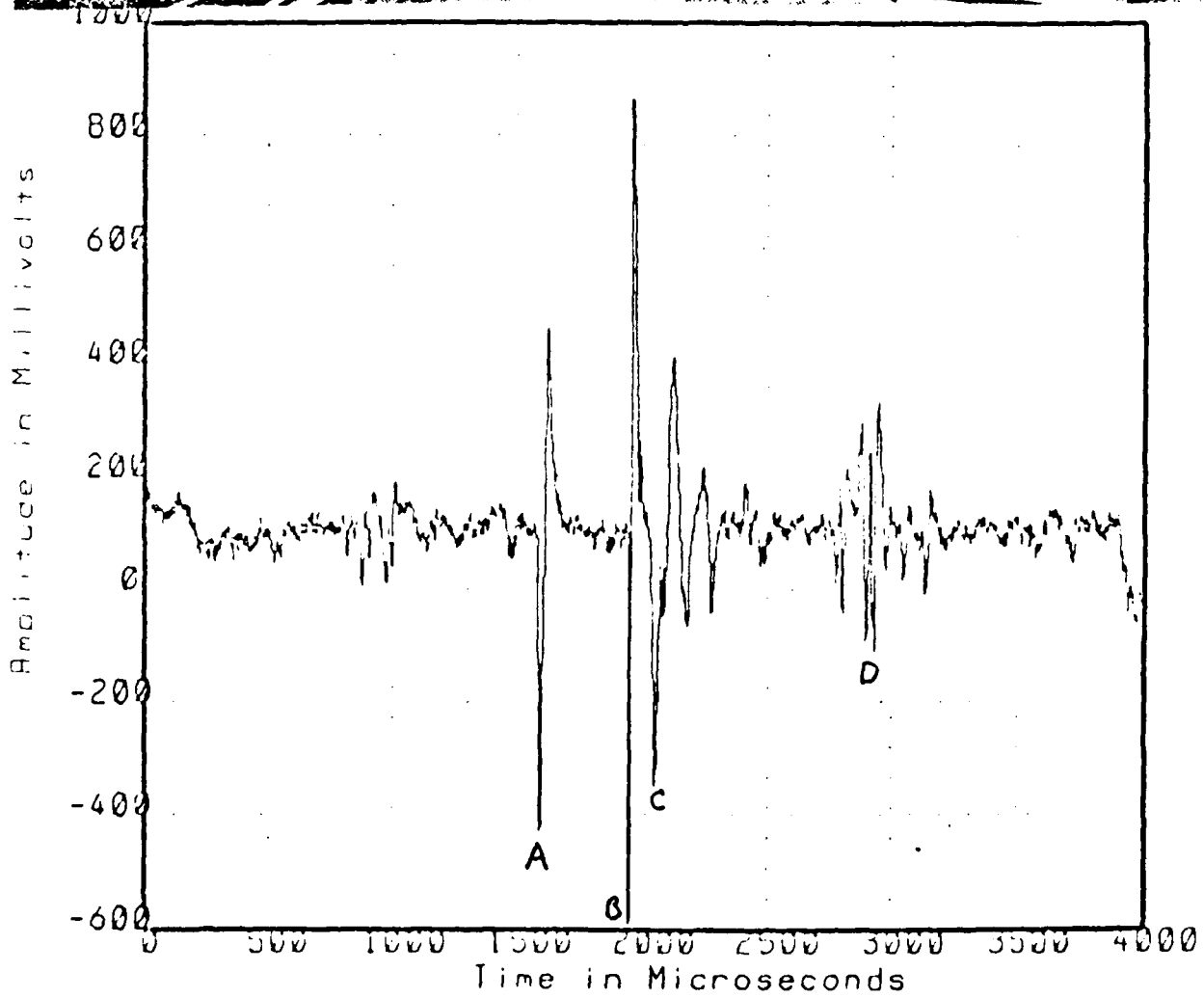
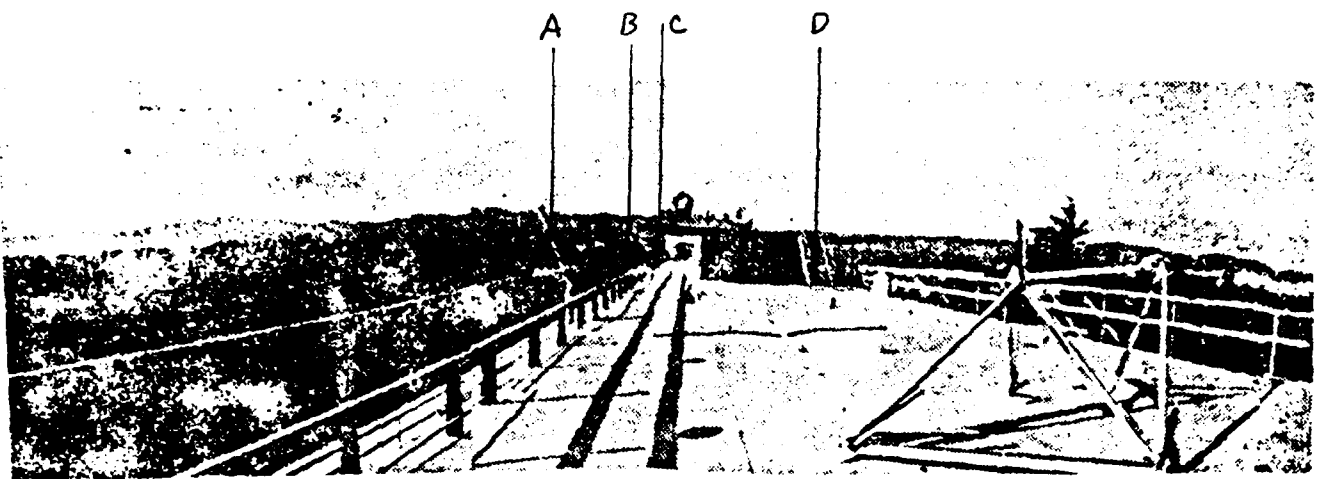

Fig.10 Scan signal and equivalent visual scene.

IX. REFERENCES

1. Ayers, Gary B., Calibration and Initialization of the NPS IRSTD System. M. S. Thesis. Naval Postgraduate School, Monterey, CA, Dec. 1987.

X. DISTRIBUTION LIST.

INITIAL DISTRIBUTION LIST

- | | | |
|-----|--|----|
| 1. | Defense Technical Information Center Cameron Station Alexandria, VA 22304-6145 | 2 |
| 2. | Library, Code 0142 Naval Postgraduate School Monterey, CA 93943-5002 | 2 |
| 3. | Professor K.E. Woehler, Code 61Wh Chairman, Department of Physics Naval Postgraduate School Monterey, CA 93943-5000 | 1 |
| 4. | Professor A.W. Cooper, Code 61Cr Naval Postgraduate School Monterey, CA 93943-5000 | 15 |
| 5. | CAPT J.A. Paine, PMS-421 Naval Sea Systems Command Washington, DC 20362-5101 | 1 |
| 6. | S.K. Petropolous, Code R42 White Oak Laboratory Naval Surface Weapons Center Detachment Silver Springs, MD 20903-5000 | 1 |
| 7. | M.W. Zurasky, Code G74 Naval Surface Weapons Center Dahlgren, VA 22448-5000 | 1 |
| 8. | Dr. D.A. Scribner, Code 6552 Naval Research Laboratory Washington, DC 20375 | 1 |
| 9. | Director, Research Administration, Code 012 Naval Postgraduate School Monterey, CA 93943 | 1 |
| 10. | Dr. R. Steinberg Applied Physics Laboratory Johns Hopkins University Laurel, MD 20707 | 1 |
| 11. | LT S.J. Smith Naval Ship Weapon Systems Engineering Station Port Hueneme, CA 93043-5007 | 1 |
| 12. | Mr. W.J. Lentz, Code 61Lz Naval Postgraduate School Monterey, CA 93943-5000 | 1 |

13. Dr. P.L. Walker, Code 61
Naval Postgraduate School
Monterey, Ca 93943-5000

1