

Naval Submarine Medical Research Laboratory



NSMRL REPORT 1153

16 January 1990



FIELD CALIBRATION OF TWO TYPES OF MICROPHONES IN HYPERBARIC AIR

by

Paul F. Smith
Susan Carpenter
and
John Green

Released by:

R. G. Walter, CAPT, DC, USN
Commanding Officer
Naval Submarine Medical Research Laboratory

Approved for public release; distribution unlimited

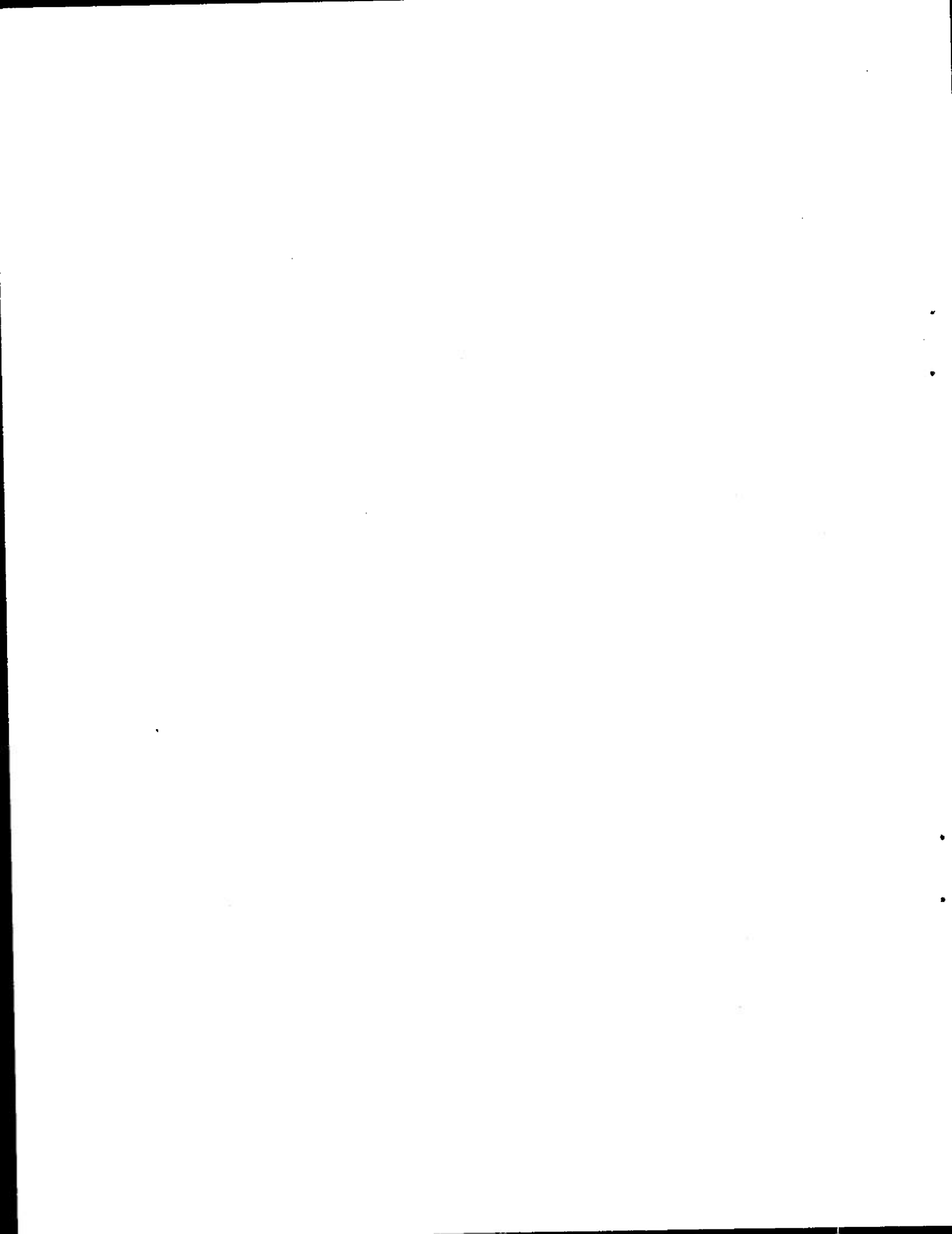

FIELD CALIBRATION OF TWO TYPES
OF MICROPHONES IN HYPERBARIC AIR

by

Paul F. Smith, Susan Carpenter, and John Green

NAVAL SUBMARINE MEDICAL RESEARCH LABORATORY
REPORT NUMBER 1153

NAVAL MEDICAL RESEARCH AND DEVELOPMENT COMMAND
RESEARCH WORK UNIT 63713N-M0099.01C-5013

Approved and Released by

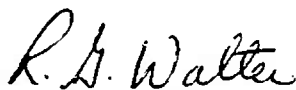

R. G. WALTER, CAPT, DC, USN
Commanding Officer
NAVSUBMEDRSCHLAB

SUMMARY PAGE

THE PROBLEM

To determine the alterations in microphone frequency response that accompany changes in ambient pressure.

THE FINDINGS

A ceramic and a condenser microphone both showed consistent alterations in frequency response as ambient pressure varied. The response alterations of the two microphones, while not identical, were quite similar.

APPLICATION

The results provide calibration data for the use of a condenser and a ceramic microphone for measuring ambient noise levels in diving environments.

ADMINISTRATIVE INFORMATION

This research was carried out under Naval Medical Research and Development Command Work Unit 63713N M0099.01C-5013, "Development of a hearing-conservation standard for exposure to noise in dry hyperbaric environments." It was submitted for review on 6 October 1988, approved for publication on 16 January 1990, and has been designated NSMRL Report No. 1153.

ABSTRACT

The response of two microphones, one a condenser microphone and the other a diaphragm-activated piezoelectric ceramic microphone, were measured in compressed air at pressures as great as 810 kilopascals (8 atmospheres). The response of each microphone was compared to that of a hydrophone operated in air as a microphone. The results show that the two types of microphone respond similarly to high ambient pressure. Both types are less sensitive to sound pressure in compressed air than in air at normal pressures, and the frequency responses of both microphones are altered. The results are useful in the analyses of ambient noise measurements done during experiments in compressed air.

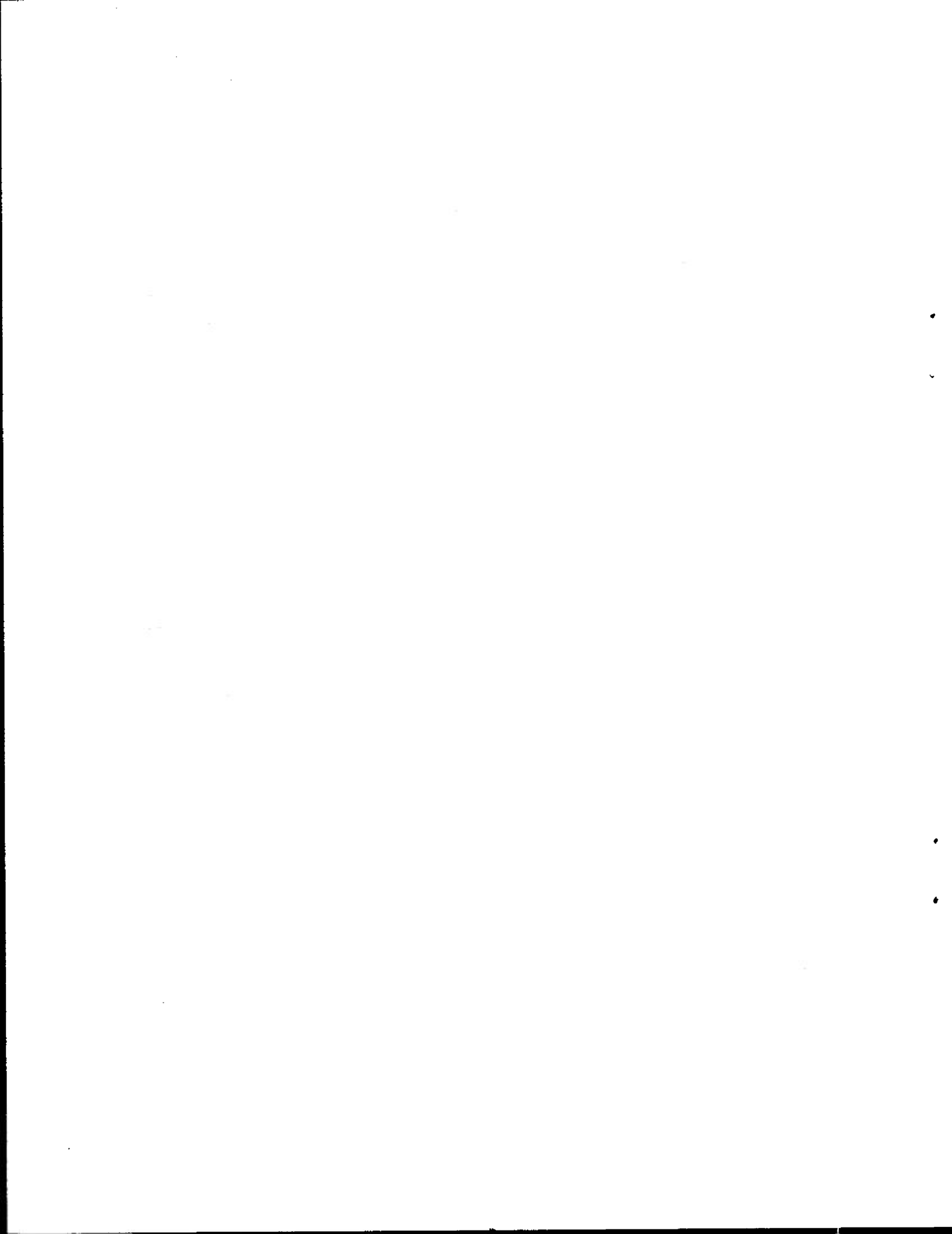

Two types of microphones have been used for making noise measurements and calibrating equipment during research on hearing in hyperbaric environments. Condenser microphones are used in helium-oxygen environments when possible because of the ease with which they may be calibrated in situ by means of an electrostatic actuator (Thomas, et al., 1972; Mullen, 1972). They have also been used in compressed air environments (Curley and Knafelc, 1987) but, because arcing can occur between the two plates of a condenser microphone, they may be a fire hazard and are not routinely permitted in compressed air environments unless the partial pressure of oxygen is below the level that readily supports combustion. Instead, piezoelectric microphones or miniature hydrophones are used.

In commenting on a paper by Chalupnik, et al. (1961), who calibrated condenser microphones in hypobaric conditions, Massa (1961) illustrated a variety of piezoelectric crystal microphones which are not affected appreciably by ambient pressure. However, the microphones he described are about 40 to 50 dB less sensitive than typical condenser microphones. In order to increase the sensitivity of a piezoelectric (whether natural crystal or ceramic) microphone, a diaphragm is connected to the crystal by a columella that exerts a concentrated force on the piezoelectric material (Kinsler, et al., 1982, p 388). The diaphragm and the crystal form two sides of a cavity having acoustical characteristics (e.g. stiffness) that are affected by gas density. Thus, while the crystal itself may not be affected by ambient static pressure, the diaphragm-activated crystal microphone as a whole is (Murry and Sergeant, 1971; Sergeant and Murry, 1971). A disadvantage of piezoelectric microphones is that simple calibration techniques that can be used in diving environments have not been developed.

Miniature piezoelectric hydrophones may also be used as microphones in air, and they have been used to measure noise within diving helmets (Molvaer and Gjestland, 1981; Molvaer and Vestrheim, 1982). Hydrophones are attractive because they are relatively unaffected by static pressures up to 40 atmospheres absolute (ATA, 1 ATA = 101.325 kilopascals). However, as noted above, the sensitivity of small piezoelectric elements is very low compared to that of diaphragm-activated microphones, so the use of hydrophones in gases has been restricted largely to measuring intense noise.

The purpose of this experiment was to perform sound-field calibrations of a condenser and a diaphragm-activated ceramic microphone at a range of ambient static pressures in compressed air by comparing the responses of the microphones with that of a miniature hydrophone when all three transducers were exposed simultaneously to narrow bands of noise.

Procedure. The condenser microphone was a Bruel and Kjaer (B&K) type 4144 pressure response microphone. The piezoelectric microphone was a Shure type 401 diaphragm-activated ceramic microphone that was supplied by Quest Electronics with their model 215R sound level meter (slm). The ceramic microphone was fitted by Quest Electronics with an impedance reducing preamplifier for use with long cables. The hydrophone was a B&K type 8104

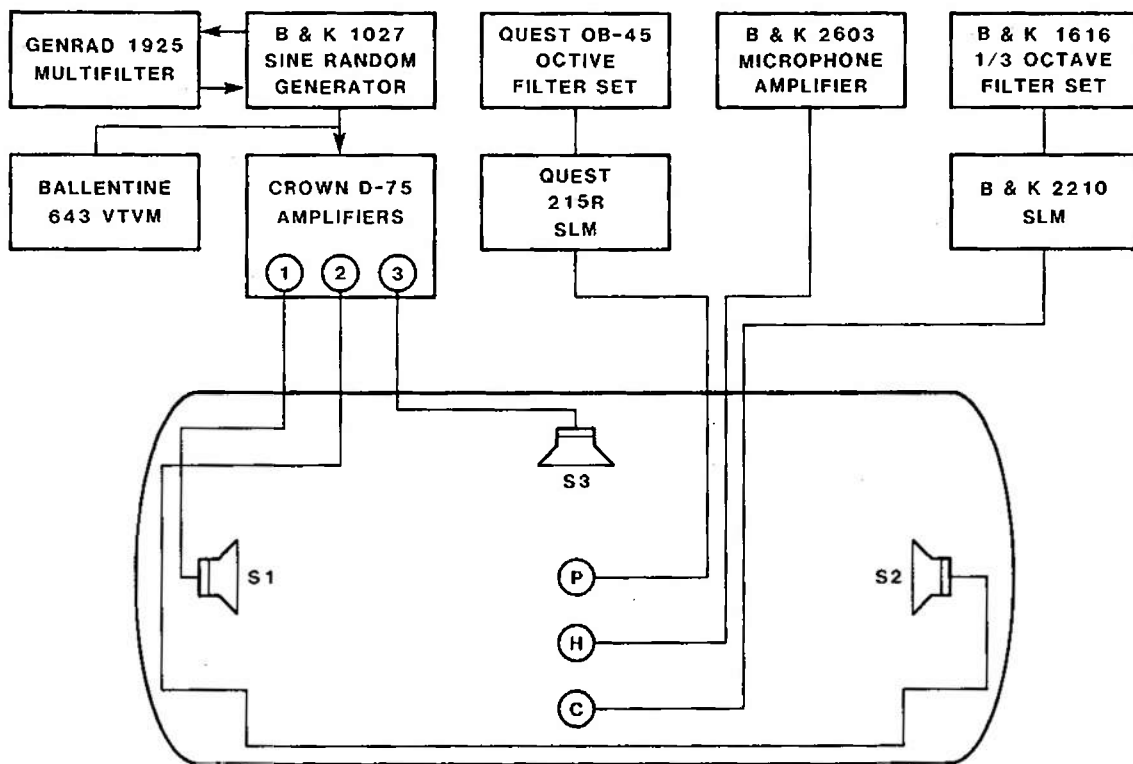

Figure 1. Instrumentation for calibration studies. Not to scale.

standard measuring hydrophone with a nominal sensitivity of -206 dB re 1 volt for an incident sound pressure of 1 micropascal (dB/V/uPa) from 20 to 2000 Hertz (Hz). Above 2000 Hz the sensitivity of the hydrophone gradually drops as frequency increases to about -211 dB/V/uPa at 10,000 Hz.

The calibrations were done within the inner lock of NSMRL Chamber #1, a steel-hulled cylindrical hyperbaric chamber having external dimensions of approximately 2.74 m diameter (X,Z axes) and 3.96 m length (Y axis). Several fixtures for the life support system protrude into the lock which is also fitted with three metal bunks along one wall. All bedding and other sound-absorbent material was removed from the chamber. The internal floodable volume of the inner lock is 28.32 m³.

Figure 1 shows that the two microphones and the hydrophone were connected through chamber pass-throughs to separate measurement systems. The B&K hydrophone (H) was connected through a standard BNC-terminated Conex pass-through to a B&K 2603 microphone amplifier. The condenser microphone (C) was connected through a seven pin pass-through designed to accept B&K microphone cables to a B&K 2210 slm which was fitted with a B&K type 1616 1/3 octave band filter set. The piezoelectric microphone (P) was connected through a BNC-terminated Conex pass-through and a 30 m cable to a Quest 215R slm fitted with a Quest model OB-45 octave band filter. The power required for the ceramic microphone preamplifier was delivered from the Quest slm through a separate BNC pass-through.

The two microphones and the hydrophone were mounted on a microphone boom located approximately in the center of the hyperbaric chamber. The two microphones were aligned along the horizontal (X) axis on either side of the hydrophone. The center-to-center distance between each microphone and the hydrophone was approximately 5.7 cm. The microphones faced upwards toward the overhead such that their active faces were in the same horizontal (X-Y) plane as the acoustic center of the hydrophone and about 1.8 m above the chamber deck plates. That plane was approximately 0.7 m below the highest point of the curved chamber overhead.

The three measurement systems were calibrated at 1 ATA immediately prior to the beginning of the experiment. The B&K 8104 hydrophone and the B&K 2603 microphone amplifier were calibrated at 250 Hz using a B&K type 4223 hydrophone calibrator with a B&K UA 0547 coupler. The B&K 2603 was calibrated to read 60 dB below the incident sound pressure level. The condenser microphone (B&K type 4144) and the B&K 2210 sound level meter were calibrated at 250 Hz at 1 ATA using a B&K 4220 pistonphone. The Shure 401 ceramic microphone and the Quest 215R slm were calibrated at 1000 Hz using a Quest model CA 128 sound calibrator.

The signal generating system is also shown in Figure 1. The noise source was an array of three Electrovoice Wolverine 8" (20.3 cm) coaxial loudspeakers in custom-fabricated 34 cm x 27 cm x 11 cm aluminum bass-reflex enclosures having 5 cm x 12.5 cm ports. They were mounted at approximately 90 degree angles near the overhead. One loudspeaker (S3) was 76 cm from the center of the receiving array; S1 and S2 were 145 cm and 137 cm from the center of the receiving array respectively.

The loudspeakers were individually driven by Crown D-75 amplifier channels set at maximum gain. The signals were 1/3 octave noise-bands derived from the B&K type 1027 sine random generator coupled to a GenRad type 1925 multifilter. The input to the amplifiers (-10 dB re 1 V) was monitored with a Ballantine model 643 vacuum tube volt meter. The signals were delivered to the loudspeakers via a 30 m cable and a Lundy-box hyperbaric chamber pass-through.

As judged by ear, the sound field around the transducer array was uniform for a broad-band noise. However, for specific one-third octave bands, one speaker or another contributed maximally to the sound field at the transducer array. Thus, the sound field was not completely diffuse but only approximately so.

The loudspeakers and microphones used in this study may behave erratically when subjected to high compression or decompression rates. Therefore, compression and decompression rates were very slow (0.1 to 0.2 ATA/min) in order to lessen the stress on the transducers and to control temperature and humidity changes accompanying compression and decompression.

Noise measurements were made both during compression and decompression. Measurements made at 1 ATA were done with the chamber door closed in order that the spatial configuration within the chamber would be constant for all tests. Upon reaching each hyperbaric pressure, the temperature was permitted to return to within 10 degrees F of the initial temperature at 1 ATA (78 degrees F) before measurements began. Once the proper pressure and temperature conditions were established, slight variations in chamber pressure (< 0.1 ATA) were permitted.

During the compression phase of the experiment, noise measurements were made at 1, 2, 3, 4, 5, and 8 ATA. Times between measurements varied according to the very slow compression/decompression rates from about 20 to 30 minutes. Measurements were made within 2 to 10 minutes after scheduled pressures were achieved and temperature stabilized. The chamber remained pressurized at 8 ATA for about 90 minutes and measurements were repeated before decompression commenced. During the decompression phase, measurements were done at 4, 2, and 1 ATA beginning immediately upon achieving scheduled ambient pressures and temperatures.

Measurement signal levels (1/3 octave-band levels of 85 to 117 dB re 20 uPa at 1 ATA) were sufficiently high throughout the experiment that extraneous sources of noise did not affect the measurements. However, the chamber compressor and chamber lights were turned off and activities generating noise were suspended while measurements were being taken. The two microphone responses were measured using appropriate octave-band or 1/3 octave-band filter settings.

Narrow bands of random noise fluctuate in amplitude over time. Band-level fluctuations varied from ± 5 dB for the band centered at 100 Hz to ± 2 dB for the band centered at 250 Hz with smaller fluctuations for all higher noise bands. All sound levels were recorded to the closest 1 dB following

"eye-ball" averaging of meter fluctuations over several seconds.

Results and Discussion. Immediately upon completion of the experiment, the pistonphone and sound calibrator procedures described above were repeated. The Shure 401 ceramic microphone and the B&K 4144 condenser microphone systems showed no change from the prior results. The hydrophone system deviated from the preliminary calibrations by 0.5 dB.

Figure 2 shows the output of the speaker array as measured by the B&K 8104 hydrophone during the compression phase of the experiment. In general, the loudspeakers became somewhat more efficient as gas density increased. That is, for a constant voltage input the speakers produced higher band levels as ambient pressure increased. The largest change in efficiency occurred between the ambient pressures of 1 to 2 ATA with further gains in efficiency more-or-less systematically varying with pressure, especially for frequencies above 1000 Hz. These results, of course, also are somewhat affected by the resonance characteristics of the hyperbaric chamber. The data for frequencies of 250 Hz and lower are less reliable than those for the higher frequencies because of the inherent variability in the narrow bands described previously. Similar results were obtained during decompression with the efficiency of the loudspeakers declining to pre-compression levels as the pressure was reduced to 1 ATA.

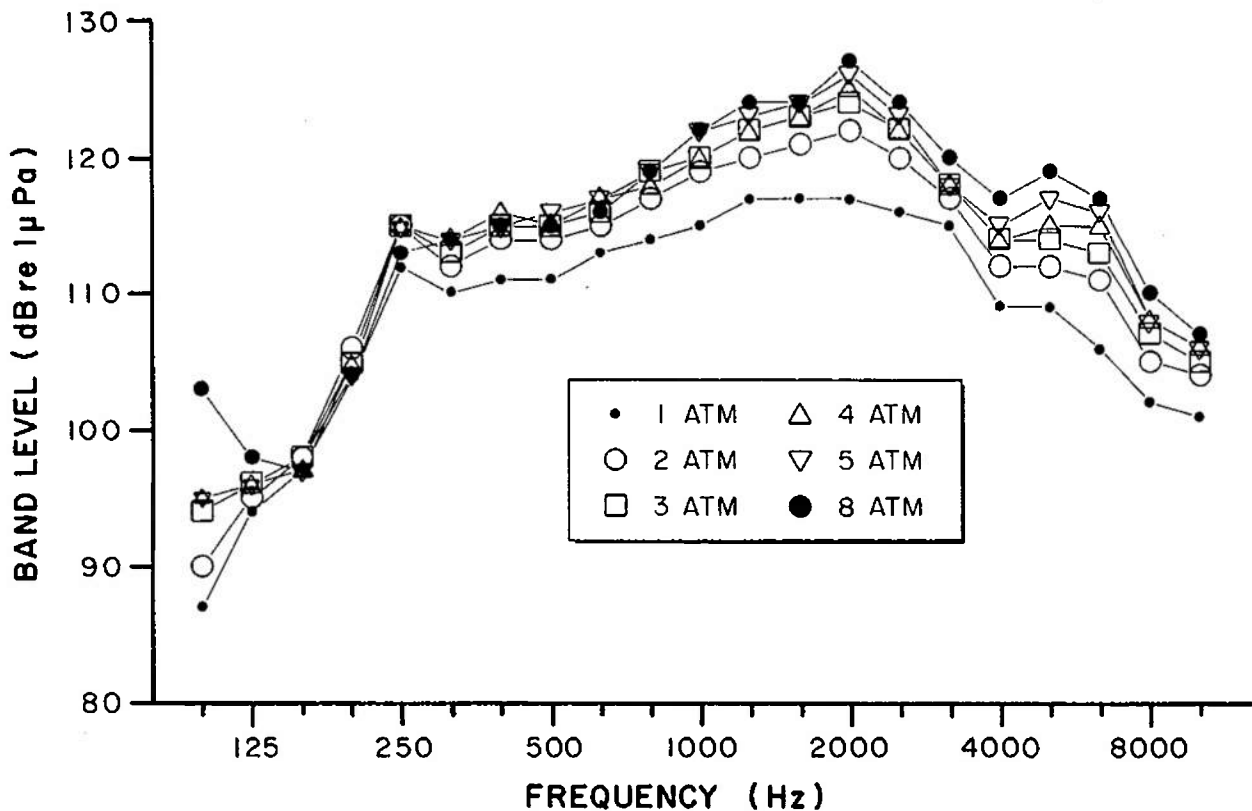

Figure 2. One-third octave band noise fields as measured by the hydrophone during the compression phase. Parameters are ambient pressure in atmospheres absolute.

The band levels shown in Figure 2 reached as high as 128 dB re 20 uPa at 8 ATA. To check that these levels were not overloading any of the measurement systems, data were taken at octave intervals of 125 to 8000 Hz with the input to the amplifiers reduced by 10 dB. The observed levels for all systems fell by 9 to 11 dB, consistent with the precision of measurement throughout the experiment.

The performance of the two microphones at various ambient pressures was obtained by subtracting the levels indicated with the hydrophone system from the levels simultaneously indicated by each microphone system.

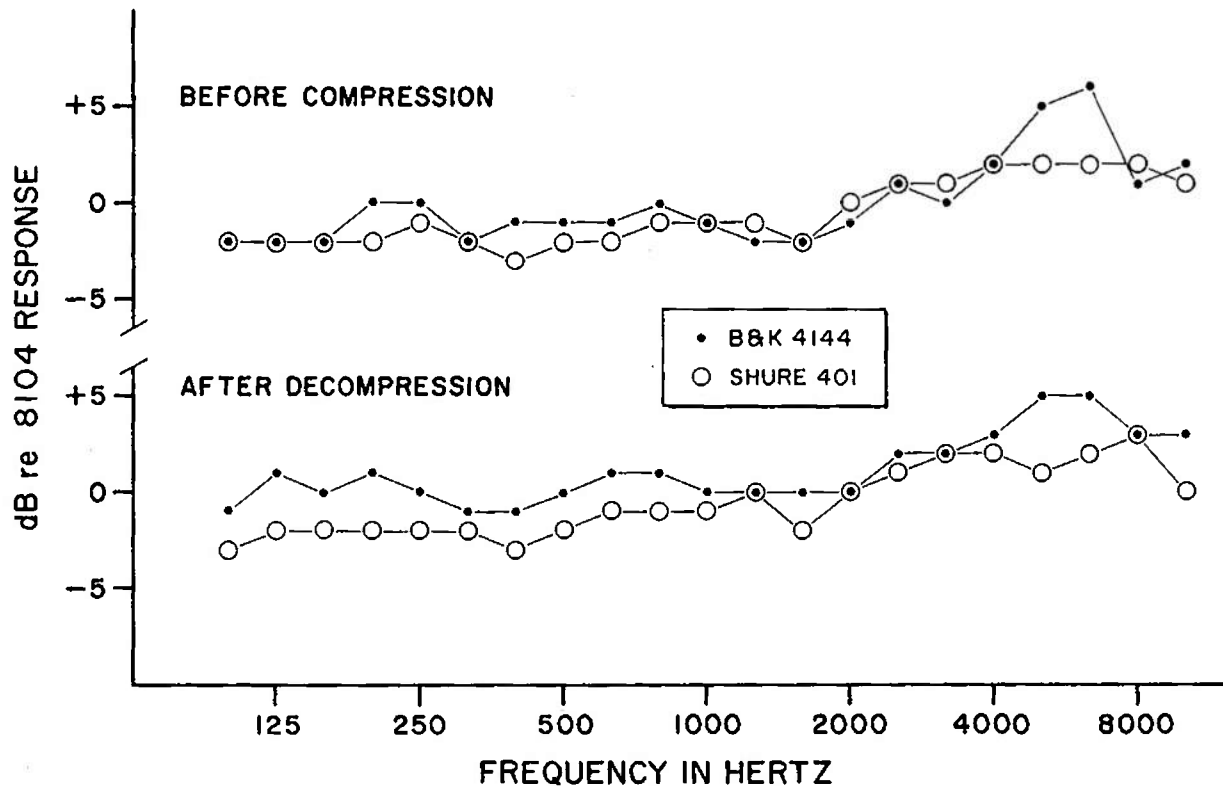

Figure 3. Comparison of the performance of the two microphones relative to the hydrophone response before and immediately following compression to 8 atmospheres absolute.

Figure 3 shows the relative responses of the condenser and the ceramic microphones with respect to the hydrophone response at 1 ATA both before compression and immediately following decompression. Before compression both microphones underestimate the hydrophone response by up to 3 dB for frequencies of 2000 Hz and below. Above 2000 Hz both microphones overestimate the hydrophone levels in part because the sensitivity of the hydrophone drops above 2000 Hz, and in part because of peculiarities of microphone design. Of course, some of the variance evident in Figures 2 and 3 is due to measurement error related to the three independent measurement systems, locations of the transducers within the sound field, etc. After decompression, the ceramic microphone returned to within 1 dB or less of its pre-compression response at all frequencies (mean difference across frequencies of 0 dB). The condenser microphone, however, appeared to be more sensitive upon return to 1 ATA than it was prior to compression (mean difference across frequencies of +1.3 dB). This microphone seems to exhibit an "overshoot" in sensitivity following hyperbaric exposure similar to that occasionally observed during previous calibrations using an electrostatic actuator.

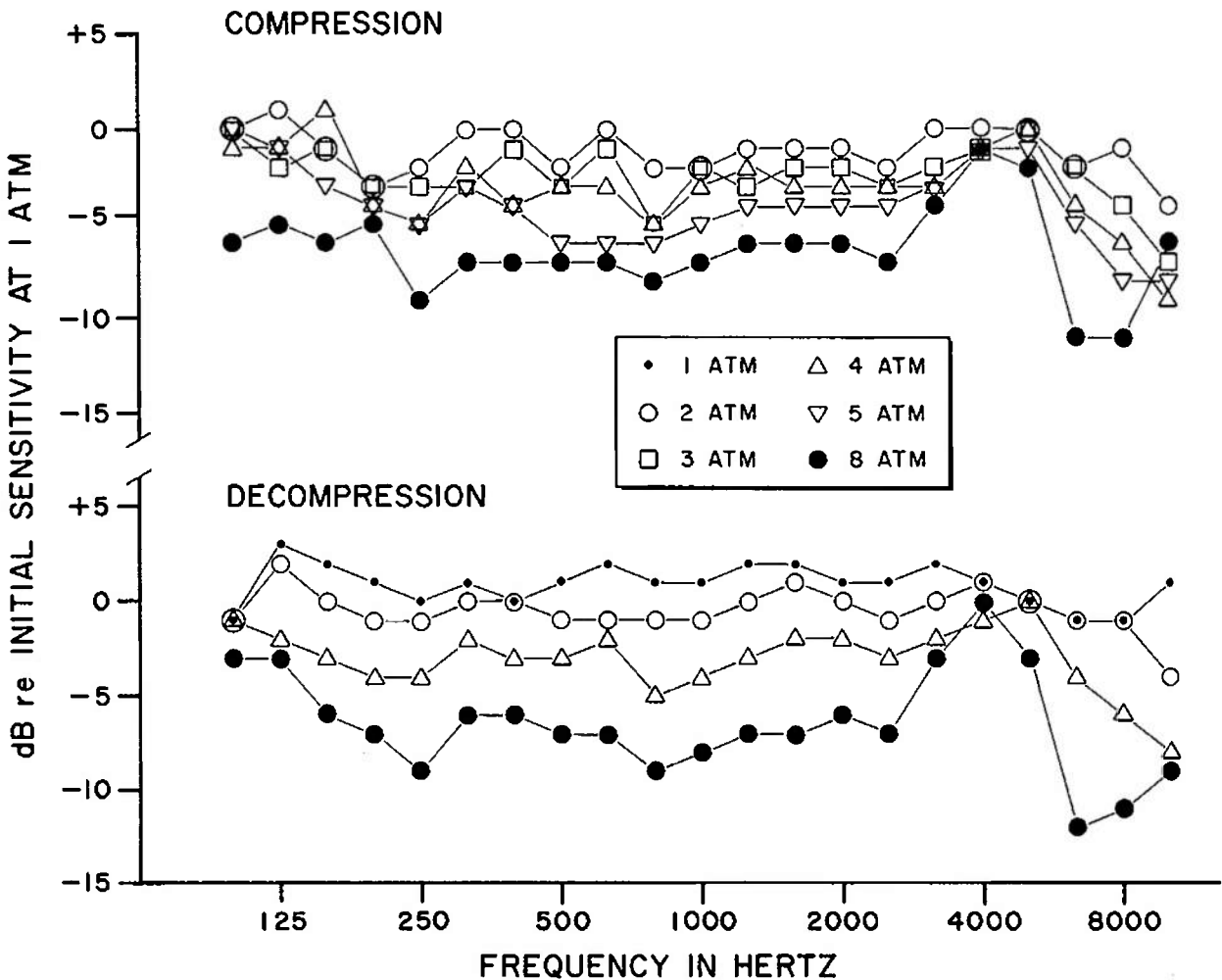

Figure 4. Frequency response of the condenser microphone relative to its frequency response at 1 atmosphere absolute prior to compression, during compression to, and decompression from 8 atmospheres absolute. Parameters are ambient pressure in atmospheres absolute.

Figure 4 shows the changes in the frequency response of the B&K condenser microphone relative to its performance at 1 ATA prior to compression for both the compression and decompression phases of the experiment. As pressure increased during the compression phase, the condenser microphone lost sensitivity at all frequencies. The smallest losses occurred at 4 khz, the largest at frequencies above 4 kHz. After 90 minutes at 8 ATA, only small changes had occurred in its frequency response from that obtained upon arrival at that pressure. During the decompression phase, the losses diminished until at 1 ATA the condenser microphone was slightly more sensitive at frequencies of 250 to 6000 Hz than it was prior to compression.

Thomas et al. (1972) calibrated a B&K type 4132 condenser microphone (similar to the 4144 in construction) with an electrostatic actuator in compressed air. They found that below 2000 Hz the condenser microphone lost roughly 1 dB of sensitivity for each 1 ATA (dB/ATA) of increased pressure in compressed air up to 7 ATA. Our results are similar for those frequencies. Both this experiment and that of Thomas et al. (1972) found losses at 8000 Hz slightly exceeding those at 2000 Hz and below. AT 4 kHz the losses of sensitivity amounted to about 4 dB at 7 ATA in the Thomas et al. experiment. Our results show only a 1 dB loss in sensitivity at 4000 Hz at 8 ATA.

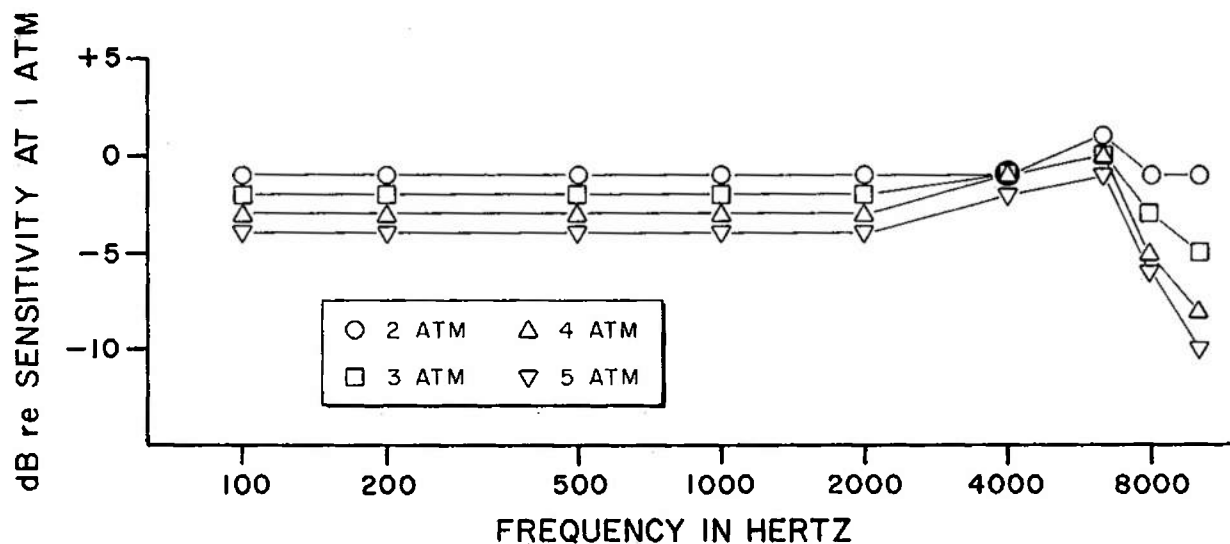

Figure 5. Changes in the frequency response of a condenser microphone at 2, 3, 4, and 5 atmospheres absolute in compressed air as determined by an electrostatic actuator. Parameters are ambient pressure in atmospheres absolute. Data from Miller, 1975.

For comparison, Figure 5 shows the results of an electrostatic calibration of a B&K type 4144 condenser microphone obtained in compressed air by Miller (1975, cited in Harris, 1980, Table III). He made two measurements at each ambient pressure both during compression and decompression. Miller's data were averaged by us and rounded to the nearest 1 dB. His results and those of Thomas et al. did not show any difference between measurements taken immediately upon reaching or ten minutes after reaching each pressure, and in neither study did the microphones exhibit "overshoot" upon return to 1 ATA. Miller's data are highly similar to those routinely observed during electrostatic calibrations of B&K 4144 microphones in this laboratory.

As Figure 5 shows, the electrostatic actuator yields a consistent pressure response for the condenser microphone up to 2000 Hz that varies with ambient pressure by about 1 dB/ATA. Above 2000 Hz the condenser microphone's response varies with frequency showing little change in sensitivity with changes in ambient pressure at 4000 Hz, perhaps 1/2 dB/ATA at 6000 Hz, but about 2.5 dB/ATA changes at 8000 Hz. Similar behavior can be seen in Figure 4 except that the noise-field calibration method used in this experiment produced more irregular results.

A comparison of Figures 4 and 5 indicates that electrostatic calibrations can be used to predict the field response of condenser microphones at pressures up to 5 ATA (Miller's maximum pressure) in compressed air with a 1 to 2 dB margin or error. This level of precision is satisfactory for routine noise measurements.

Figure 6 shows our results for the Shure 401 ceramic microphone. As pressure increased during the compression phase, the ceramic microphone exhibited a loss of sensitivity quite similar to that shown by the condenser microphone differing only in detail. For example, at 4000 Hz the condenser microphone suffers very little change in sensitivity and that frequency appears to represent a resonance. The ceramic microphone, on the other hand, shows a consistent loss of sensitivity at 4000 Hz but it exhibits resonance at 2000 Hz. The ceramic microphone may be slightly more consistent than the condenser microphone in that as the ambient pressure returns toward 1 ATA, the ceramic microphone shows little, if any, "overshoot" in the recovery of sensitivity.

At 2 ATA during the compression phase, the multifilter was switched out of the noise-generating circuit so that a broad-band noise, shaped only by the speaker system, ensonified the hyperbaric chamber. All three measurements of that noise on the linear scale of all three instruments indicated exactly the same SPL (108 dB) despite the differences in frequency responses exhibited by the measurement systems.

Murry and Sergeant (1971) found a ceramic microphone to be more consistent than a condenser microphone in its response to compression and decompression and the only one of three types of microphones tested that immediately returned to its pre-dive frequency response. Our results agree with that finding to the extent that the ceramic microphone exhibited no "overshoot" as did the condenser microphone. However, both microphones

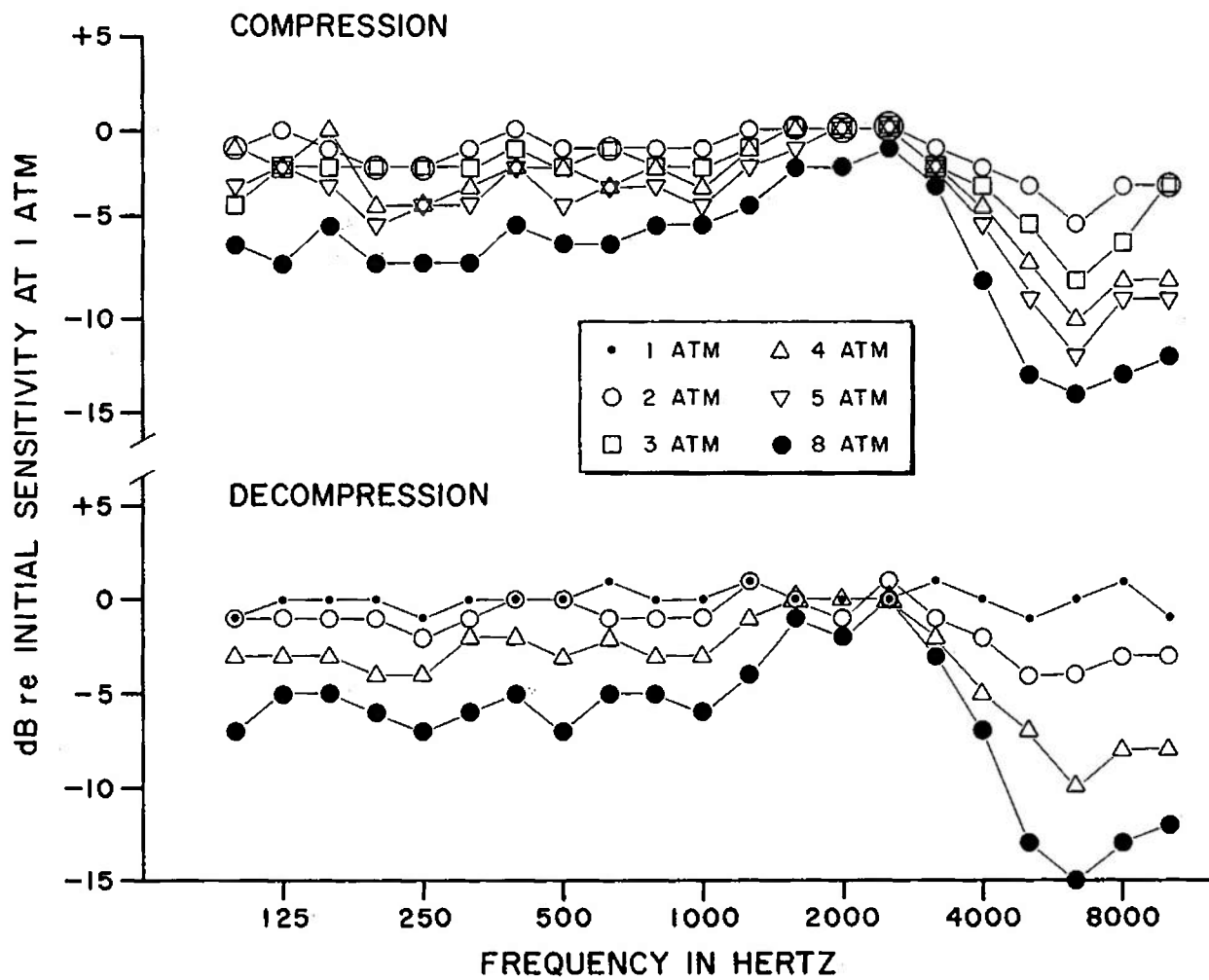

Figure 6. Frequency response of the ceramic microphone relative to its frequency response at 1 atmosphere absolute prior to compression, during compression to, and decompression from 8 atmospheres. Parameters are ambient pressure in atmospheres absolute.

exhibited reasonably orderly changes in sensitivity with changes in ambient pressure. Also, "overshoot" does not always occur in a condenser microphone; when it does occur the overshoot is not larger than about 1 to 1.5 dB and usually lasts but a short time. The post-experiment pistonphone calibration of the condenser microphone showed no change (at 250 Hz) from the pre-compression calibrations. Furthermore, the present results and the Murry and Sergeant results are based upon the performance of only two piezoelectric microphones. It can hardly be concluded that all piezoelectric microphones always immediately return to pre-compression sensitivity. Recall that the hydrophone used in this work exhibited a 0.5 dB change in sensitivity (pistonphone, 250 Hz) upon return to 1 ATA.

Conclusions. The results of this experiment show that diaphragm-activated ceramic microphones constructed like the Shure 401 exhibit losses in sensitivity when exposed to hyperbaric air that are similar to those found for condenser microphones. Therefore, piezoelectric microphones cannot be assumed to be insensitive to ambient pressure. The results also show that calibrations performed using electrostatic actuators on condenser microphones predict free-field microphone responses with an accuracy of about ± 2 dB at least to ambient pressures of 5 ATA. For routine noise measurements (as for hearing-conservation purposes) that level of accuracy is sufficient. Small differences between the frequency responses of microphones that are induced by hyperbaric pressure (similar to those found for these two microphones) may have little or no effect on the accuracy of broad-band measurements (as on a linear or A weighted scale) of broad-band noise.

References

- Chalupnik, J. D., Rule, E., and Suellentrop, F. J. (1961). "Pressure response of condenser microphones at low ambient pressures." J. Acoust. Soc. Amer., 33, 177-178.
- Curley, M. D., and Knafelc, M. E. (1987). "Evaluation of noise within the MK 12 SSDS helmet and its effect on divers' hearing." Undersea Biomed Res. 14, 187-204.
- Harris, J. D. (1980). "NSMRL calibration of microphones at depth in dry hyperbaric chambers." J. Acoust. Soc. of Amer., 67, 327-332.
- Kinsler, L. E., Frey, A. R., Coppens, A. B., and Sanders, J. V. (1982). Fundamentals of Acoustics, third edition. New York: John Wiley & Sons, Inc.
- Massa, F. (1961). "Comments on 'Pressure response of condenser microphones at low ambient pressures'." J. Acoust. Soc. Amer., 33, 810.
- Miller, T. (1975). "Calibration of TDH-39 earphones and B&K 1-inch condenser microphone type 4144 at ambient pressures from 1 to 5 ATA (surface to 132 fsw)." Unpublished internal NSMRL report; results presented and discussed by Harris, 1980.
- Molvaer, O. I., and Gjestland, T. (1981). "Hearing damage to divers operating noisy tools underwater." Scand. J. Work Environ Health, 7, 263-270.
- Molvaer, O. I., and Vestrheim, M. (1982). "Noise in a standard dive helmet." Norwegian Underwater Technology Center Report 28-82.
- Mullen, W. W., Jr. (1972). "Condenser microphone calibration and response in deep diving environments." J. Audio Engineering Society, 20, 112-115.
- Murry, T., and Sergeant, R. L. (1971). "Response variation of three types of microphones pressurized to 19 ATA." Naval Submarine Medical Research Laboratory Report 690.
- Sergeant, R. L., and Murry, T. (1971). "Reciprocity calibration of microphones under high ambient pressures." Naval Submarine Medical Research Laboratory Report 671.
- Thomas, W. G., Preslar, M. J., and Farmer, J. C. (1972). "Calibration of condenser microphones under increased atmospheric pressure." J. Acoust. Soc. Amer., 51, 6-14.

UNCLASSIFIED

SECURITY CLASSIFICATION OF THIS PAGE

REPORT DOCUMENTATION PAGE				Form Approved OMB No 0704-0188	
1a REPORT SECURITY CLASSIFICATION UNCLASSIFIED			1b RESTRICTIVE MARKINGS		
2a. SECURITY CLASSIFICATION AUTHORITY			3. DISTRIBUTION / AVAILABILITY OF REPORT		
2b. DECLASSIFICATION / DOWNGRADING SCHEDULE			Approved for public release; distribution unlimited		
4. PERFORMING ORGANIZATION REPORT NUMBER(S) NSMRL Report 1153			5. MONITORING ORGANIZATION REPORT NUMBER(S)		
6a. NAME OF PERFORMING ORGANIZATION Naval Submarine Medical Research Laboratory		6b. OFFICE SYMBOL (if applicable)	7a. NAME OF MONITORING ORGANIZATION Naval Medical Research and Development Command		
6c. ADDRESS (City, State, and ZIP Code) Box 900, Naval Submarine Base NLON Groton, CT 06349-5900			7b. ADDRESS (City, State, and ZIP Code) National Naval Medical Center Bethesda, MD 10814-5044		
8a. NAME OF FUNDING / SPONSORING ORGANIZATION Same as 7a		8b. OFFICE SYMBOL (if applicable)	9 PROCUREMENT INSTRUMENT IDENTIFICATION NUMBER		
8c. ADDRESS (City, State, and ZIP Code) Same as 7b			10 SOURCE OF FUNDING NUMBERS		
			PROGRAM ELEMENT NO 63713N	PROJECT NO M0099	TASK NO 01C
			WORK UNIT ACCESSION NO. 5013		
11. TITLE (Include Security Classification) (U) Field calibration of two types of microphones in hyperbaric air					
12. PERSONAL AUTHOR(S) Smith, Paul F., Carpenter, Susan, and Green, John					
13a. TYPE OF REPORT Interim		13b. TIME COVERED FROM 10/88 TO 10/89		14. DATE OF REPORT (Year, Month, Day) 1990 January 16	15. PAGE COUNT 14
16. SUPPLEMENTARY NOTATION					
17. COSATI CODES			18. SUBJECT TERMS (Continue on reverse if necessary and identify by block number)		
FIELD	GROUP	SUB-GROUP	noise exposure; hyperbaric environments; hearing conservation; acoustics		
19. ABSTRACT (Continue on reverse if necessary and identify by block number) The response of two microphones, one a condenser microphone and the other a diaphragm-activated piezoelectric ceramic microphone, were measured in compressed air at pressures as great as 810 kilopascals (8 atmospheres). The response of each microphone was compared to that of a hydrophone operated in air as a microphone. The results show that the two types of microphone respond similarly to high ambient pressure. Both types are less sensitive to sound pressure in compressed air than in air at normal pressures, and the frequency responses of both microphones are altered. The results are useful in the analyses of ambient noise measurements done during experiments in compressed air.					
20. DISTRIBUTION / AVAILABILITY OF ABSTRACT <input checked="" type="checkbox"/> UNCLASSIFIED/UNLIMITED <input type="checkbox"/> SAME AS RPT <input type="checkbox"/> DTIC USERS			21. ABSTRACT SECURITY CLASSIFICATION UNCLASSIFIED		
22a. NAME OF RESPONSIBLE INDIVIDUAL Susan D. Monty, Publications Office			22b. TELEPHONE (Include Area Code) (203) 449-3967	22c. OFFICE SYMBOL 421	

SECURITY CLASSIFICATION OF THIS PAGE

