

AD-A221 032

FINAL REPORT
FOR
ORIENTED SCINTILLATION
SPECTROMETER EXPERIMENT (OSSE)

DTIC FILE COPY

DOCUMENT NO. EX056-041
INITIAL ISSUE
1 DECEMBER 1987

DTIC
SELECTE
MAY 02 1990
S D D
cy

CONTRACT NO. N00014-79-C-0389
CDRL C025

Prepared for
Naval Research Laboratory
Washington, D.C.

DISTRIBUTION STATEMENT A
Approved for public release
Distribution Unlimited

Prepared by
Ball Aerospace Systems Division (BASD)
P.O. Box 1062
Boulder, Colorado 80306

PREPARED BY:

S. Henninger
S. Henninger

APPROVED BY:

S. Varlese
S. Varlese
OSSE Program Manager

TABLE OF CONTENTS

PART 1	
1.1	ELECTRONICS OVERVIEW..... 7
1.2	MECHANICAL OVERVIEW..... 11
1.3	SUBSYSTEMS..... 14
1.3.1	CPM ELECTRONICS ASSEMBLY..... 14
1.3.2	CENTRAL ELECTRONICS CABLING..... 14
1.3.3	HIGH VOLTAGE DISTRIBUTION CABLING..... 19
1.3.4	RIU INTERFACE..... 19
1.3.5	THERMAL BUS POWER CONTROL DESCRIPTION..... 19
1.3.6	MAKE-UP BUS POWER CONTROL DESCRIPTION..... 19
PART 2	
2.1	OSSE CONNECTOR ASSIGNMENT..... 25
2.1.1	IDENTIFICATION MARKING..... 25
2.2	OSSE COMMAND AND TELEMETRY LISTS..... 43
2.3	OSSE PMT TUBE NUMBERING SYSTEM..... 43
2.4	OSSE DETECTOR NUMBERING SYSTEM..... 48
2.5	THERMISTOR CALIBRATION CURVES..... 48
PART 3	
3.1	HOUSEKEEPING VALUES..... 50
3.2	DRIVE POTENTIOMETER CALIBRATION CURVES..... 62
3.3	OSSE POWER CONSUMPTION SUMMARY..... 71
3.4	ALIGNMENT SUMMARY (MECHANICAL, PRE-CALIBRATION)..... 73
3.4.1	ALIGNMENT REQUIREMENTS..... 73
3.4.1.1	METHODS..... 73
3.4.1.2	FINAL RESULTS..... 74
3.4.2	DETECTOR FOV WITH RESPECT TO OSSE AXIS..... 89
3.4.2.1	COLLIMATOR TILT WITH RESPECT TO THE DETECTOR ROTATION AXIS..... 89
3.4.2.2	LONG/SHORT AXIS MISALIGNMENT WITH SCAN AXIS, INSTRUMENT AXIS, OR BOTH..... 89
3.4.3	DETECTOR ROTATION AXIS WITH RESPECT TO OSSE AXIS..... 89
3.4.3.1	DETECTOR AXIS NOT COINCIDING WITH OSSE Y AXIS, ROTATED ABOUT X AXIS..... 89
3.4.3.2	DETECTOR AXIS NOT COINCIDING WITH OSSE Y AXIS, ROTATED ABOUT Z AXIS..... 90
3.4.3.3	COMBINED DETECTOR AXIS MISALIGNMENT..... 90
3.4.4	COMPLIANCE OF RESULTS TO REQUIREMENTS (3.5.1 ALIGNMENT OBJECTIVE)..... 93
3.4.5	POT LINEARITY AND STEP SIZE CALIBRATION..... 93
3.4.6	AIMS STRUCTURE SURVEYS..... 106
3.5	SYSTEM-LEVEL ENVIRONMENTAL TESTS..... 108
3.5.1	OPERATION REPORT, PROOF MODEL STRUCTURE TESTS... 108
3.5.1.1	PROOF MODEL MODAL SURVEY TEST..... 108
3.5.1.2	PROOF MODEL STATIC LOAD TEST..... 114
3.5.1.3	PROOF MODEL ACOUSTIC TEST..... 118
3.5.2	MASS PROPERTIES SUMMARY - WEIGHT AND C.G..... 122
3.5.3	OPERATION REPORT, BASELINE FUNCTIONAL TEST..... 123
3.5.4	OPERATION REPORT, OSSE FLIGHT INSTRUMENT THERMAL-VACUUM TEST..... 125
3.5.4.1	TEST OBJECTIVE..... 125
3.5.4.2	FACT SUMMARY..... 125

3.5.4.3	RESULTS VS. TEST OBJECTIVE.....	126
3.5.4.4	CHRONOLOGY OF TEST MILESTONES.....	126
3.5.4.5	TEST ANOMALIES.....	129
3.5.5	OSSE FLIGHT INSTRUMENT ACOUSTIC TEST.....	134
3.5.6	OPERATION REPORT: OSSE POST-ACOUSTIC FUNCTIONAL.....	139
3.5.7	OSSE EMI TEST SUMMARY.....	140
PART 4		
4.1	LESSONS LEARNED WHILE BUILDING OSSE.....	141

TABLES

TABLE 1-1	OSSE EXPERIMENT SUMMARY.....	6
1-2	CABLE IDENTIFICATION.....	17
2-1	OSSE CONNECTOR ASSIGNMENT.....	26
2-2-1	OSSE CONNECTOR PIN ASSIGNMENT.....	27
2-2-2	OSSE CONNECTOR PIN ASSIGNMENT.....	28
2-2-3	OSSE CONNECTOR PIN ASSIGNMENT.....	29
2-2-4	OSSE CONNECTOR PIN ASSIGNMENT.....	30
2-2-5	OSSE CONNECTOR PIN ASSIGNMENT.....	31
2-2-6	OSSE CONNECTOR PIN ASSIGNMENT.....	32
2-2-7	OSSE CONNECTOR PIN ASSIGNMENT.....	33
2-2-8	OSSE CONNECTOR PIN ASSIGNMENT.....	34
2-2-9	OSSE CONNECTOR PIN ASSIGNMENT.....	35
2-2-10	OSSE CONNECTOR PIN ASSIGNMENT.....	36
2-2-11	OSSE CONNECTOR PIN ASSIGNMENT.....	37
2-2-12	OSSE CONNECTOR PIN ASSIGNMENT.....	38
2-2-13	OSSE CONNECTOR PIN ASSIGNMENT.....	39
2-2-14	OSSE CONNECTOR PIN ASSIGNMENT.....	40
2-2-15	OSSE CONNECTOR PIN ASSIGNMENT.....	41
2-2-16	OSSE CONNECTOR PIN ASSIGNMENT.....	42
3-1	VIDEO MONITOR PAGES 01,02,03.....	51
3-2	VIDEO MONITOR PAGES 05,06,07.....	52
3-3	VIDEO MONITOR PAGES 09,10,11.....	53
3-4	VIDEO MONITOR PAGES 12,13,14.....	54
3-5	VIDEO MONITOR PAGES 15,16,17.....	55
3-6	VIDEO MONITOR PAGES 18,19,20.....	56
3-7	VIDEO MONITOR PAGES 21,22,23.....	57
3-8	VIDEO MONITOR PAGES 24,25,30.....	58
3-9	VIDEO MONITOR PAGES 31,32,34.....	59
3-10	VIDEO MONITOR PAGES 35,36,42.....	60
3-11	VIDEO MONITOR PAGES 43.....	61
3-12	QUIET BUS CURRENT AND POWER.....	71
3-13	MAKEUP BUS CURRENT AND POWER.....	72
3-14	THERMAL BUS CURRENT AND POWER.....	72
3-15	ALIGNMENT ERROR BUDGET, FOV, A1.....	76
3-16	ALIGNMENT ERROR BUDGET, ROTATION AXIS, A1.....	77
3-17	ALIGNMENT ERROR BUDGET, FOV, A2.....	78
3-18	ALIGNMENT ERROR BUDGET, ROTATION AXIS, A2.....	79
3-19	ALIGNMENT ERROR BUDGET, FOV, A3.....	80
3-20	ALIGNMENT ERROR BUDGET, ROTATION AXIS, A3.....	81
3-21	ALIGNMENT ERROR BUDGET, FOV, A4.....	82
3-22	ALIGNMENT ERROR BUDGET, ROTATION AXIS, A4.....	83
3-23	OSSE PROOF MODEL MODAL SURVEY.....	113

3-24	OSSE PROOF MODEL STATIC LOAD TEST.....	116
3-25	OSSE PROOF MODEL QUAL-ACOUSTIC PROFILE.....	120
FIGURE 1-1	INSTRUMENT SUBSYSTEMS AND ASSEMBLIES.....	9
1-2	OSSE BLOCK DIAGRAM.....	10
1-3	INSTRUMENT GENERAL ARRANGEMENT.....	12
1-4	DETECTOR SUBSYSTEM.....	13
1-5	CPM ELECTRONICS BLOCK DIAGRAM.....	15
1-6	CPM ELECTRONICS ASSEMBLY PACKAGING.....	16
1-7	CE CABLING.....	18
1-8	RIU COMMAND INTERFACE BLOCK DIAGRAM.....	21
1-9	RIU TELEMETRY INTERFACE BLOCK DIAGRAM.....	22
1-10	PCU THERMAL BUS DETECTOR ACTIVE HEATER SWITCHING.....	23
1-11	MAKEUP BUS POWER SWITCHING AND TEMPERATURE CONTROL.....	24
2-1	DETECTOR A1 PMT IDENTIFICATION.....	44
2-2	DETECTOR A2 PMT IDENTIFICATION.....	45
2-3	DETECTOR A3 PMT IDENTIFICATION.....	46
2-4	DETECTOR A4 PMT IDENTIFICATION.....	47
2-5	DETECTOR TEMPERATURE SENSORS.....	49
3-1	SYSPOTLIN, DET A1, MAIN.....	63
3-2	SYSPOTLIN, DET A2, MAIN.....	64
3-3	SYSPOTLIN, DET A3, MAIN.....	65
3-4	SYSPOTLIN, DET A4, MAIN.....	66
3-5	SYSPOTLIN, DET A1, REDN.....	67
3-6	SYSPOTLIN, DET A2, REDN.....	68
3-7	SYSPOTLIN, DET A3, REDN.....	69
3-8	SYSPOTLIN, DET A4, REDN.....	70
3-9	DETECTOR A1 ALIGNMENT ERRORS.....	85
3-10	DETECTOR A2 ALIGNMENT ERRORS.....	86
3-11	DETECTOR A3 ALIGNMENT ERRORS.....	87
3-12	DETECTOR A4 ALIGNMENT ERRORS.....	88
3-13	Y-Z PLANE MISALIGNMENTS.....	91
3-14	X-Y PLANE MISALIGNMENTS.....	92
3-15	POT VS ANGLE, DETECTOR A1.....	95
3-16	POT VS ANGLE, DETECTOR A1.....	96
3-17	POT VS ANGLE, DETECTOR A1.....	97
3-18	POT VS ANGLE, DETECTOR A2.....	98
3-19	POT VS ANGLE, DETECTOR A2.....	99
3-20	POT VS ANGLE, DETECTOR A2.....	100
3-21	POT VS ANGLE, DETECTOR A3.....	101
3-22	POT VS ANGLE, DETECTOR A3.....	102
3-23	POT VS ANGLE, DETECTOR A3.....	103
3-24	POT VS ANGLE, DETECTOR A4.....	104
3-25	POT VS ANGLE, DETECTOR A4.....	105
3-26	OSSE PROOF MODEL MODAL SURVEY.....	112
3-27-1	OSSE PROOF MODEL STATIC LOAD TEST.....	116
3-27-2	OSSE PROOF MODEL STATIC LOAD TEST.....	117
3-28-1	OSSE PROOF MODEL ACCELEROMETER LOCATIONS.....	119
3-28-2	OSSE PROOF MODEL ONE MINUTE ACOUSTIC TEST.....	121
3-29	OSSE INSTRUMENT THERMAL VACUUM TEST.....	133
3-30	OSSE ACOUSTIC TEST ONE MINUTE QUAL.....	138
APPENDIX 1	EX 056-007, BASD OSSE DESIGN DESCRIPTION DOCUMENT..	A-1
APPENDIX 2	NO. 0926-001, OSSE COMMAND AND TELEMETRY DOCUMENT..	A-2

APPENDIX 3 ENV-R584, ELECTROMAGNETIC COMPATIBILITY/ELECTRO-
MAGNETIC INTERFERENCE (EMC/EMI) TEST REPORT
FOR THE OSSE INSTRUMENT.....A-3

APPENDIX 4 DD150664 OSSE INSTRUMENT HANDLING PROCEDURE.....A-4

INTRODUCTION

The Final Report on the Oriented Scintillating Spectrometer Experiment (OSSE) is a reference document formatted in four parts to provide a concise summary of data covering the building and the testing of this Instrument. The main purpose of this document is to provide useful data for spacecraft integration activity. Most of the material is not original - it is pulled together from the more pertinent contents of the following categories: 1) description of OSSE, as specified, 2) construction data, and 3) test and measurement data, all drawn from design and test documentation. A fourth section, however, is drawn from original thinking on the subject of how OSSE might have been built and tested differently in order to achieve better results - the "lessons learned" section. This final section will be more directed toward contributing to the improvement of future such programs, rather than contributing to spacecraft integration as significantly as the first three sections are intended to do.

 PART 1 OSSE INSTRUMENT AND SUBSYSTEM DESCRIPTION

TABLE 1-1. OSSE EXPERIMENT SUMMARY (table 2-1 of EX056-007A)

A. Detectors		
1. Type		Four identical NaI-Csi phoswiches, actively-shielded
2. Aperture Area (total)		2685 cm ²
Effective Area		2310 cm ² @ 0.54 MeV 867 cm ² @ 4.43 MeV
3. Field-of-View		+/-3.8 x +/-11.4 degrees FWHM @ 0.51 MeV (rectangular collimator holes)
4. Energy Range		0.05-10 MeV gamma rays (primary objective) 10-150 MeV gamma-rays (secondary objective) >10 MeV solar neutrons (secondary objective)
5. Energy Resolution		<=8.0% @ 0.661 MeV <=3.2% @ 6.13 MeV
6. Time Resolution		1,2,4,8,16,32 sec in normal mode 0.125 msec in pulsar mode 4,8,16,32 msec in burst mode
7. Stability		<=0.1% over 10 min <=1% over 24 hours
B. Experiment Objectives		
1. 0.1-10 MeV line gamma-rays (10 ⁻⁶ sec)		approx 2x10 ⁻⁵ gamma/cm ² -sec
2. 0.1-1 MeV continuum gamma-rays		0.005X Crab
1-10 MeV continuum gamma-rays		0.02X Crab
3. Gamma-Ray Burst		10 ⁻⁷ ergs/cm ²
4. Solar Flare Line gamma-rays (10 ⁻³ sec flare)		5 x 10 ⁻⁴ photons/cm ² - s
5. Solar Flare Neutrons (>10 MeV)		5 x 10 ⁻³ n/cm ² - s

Accession For	
NTIS	CRAB
DTIC	TAB
Unannounced Justification	
By <i>per etc</i>	
Distribution/	
Availability Codes	
Dist	Availability
Special	
A-1	

TABLE 1-1 OSSE EXPERIMENT SUMMARY (table 2.1 of EX056-007A, cont)

C. Pointing System	
1. Type:	Independent Single Axis per Detector
2. Drive System	Redundant Stepper Motor
3. Maximum Drive Speed	2 degrees/sec
4. Accuracy	Absolute \leq 0.25 degree Calibrated to \leq 0.1 degree
D. GRO-Experiment Interface Data	
1. Telemetry	PCM Serial Data Line: 6492 BPS
2. Command	8 PCM serial commands +62 discrete commands
3. Weight	4193 lbs maximum lbs actual
4. Moment of Inertia	11.5 slug-ft ²

The following text is excerpted from the BASD document EX056-007A, Rev __, which provides overviews of the OSSE Instrument in two aspects, electronic and mechanical.

1.1 ELECTRONICS OVERVIEW

Figure 1-1 is a block diagram of OSSE subsystems and Assemblies. Figure 1-2 is a block diagram of the complete OSSE instrument. The electronics complement for OSSE includes four sets of Detector Electronics Assemblies, Central Electronics Subsystem, Drive Electronics Assembly, and Charged Particle Monitor Electronics Assembly. The Central Electronics Subsystem includes redundant Processor Electronics Assemblies, Power Control Unit Assembly, and redundant Central Electronics Low Voltage Power Supply Subassemblies. The Drive Electronics Assembly includes four redundant sets of motor drive circuits and support circuits. The Charged Particle Monitor Electronics Assembly includes redundant electronics and high voltage power supplies.

The Detector Electronics Assembly contains all the circuitry to completely support the Detector Subsystem including Phoswich, Annular Shields, Charged Particle Detector, and the Co60 Assembly. This encompasses low level front-end circuitry, event processing circuits, interface circuitry, command circuits, high voltage power supplies, heater control circuit, housekeeping/status circuitry, an AGC system, and low voltage power supply (LVPS).

The Central Electronics Subsystem forms the complete interface between the observatory Remote Interface Unit (RIU) and the four Detector Subsystems. It performs all control functions for collection, formatting, and readout of data, both scientific and housekeeping/status. The Processor Electronics (part of CE) contains the microprocessor/support electronics and is completely redundant. The Power Control Unit (part of CE) contains power switching, monitoring, and interface for all primary power to the instrument. It also contains secondary

power switching and monitoring for the drive electronics as well as thermostats and monitors for the make-up and shuttle operations heater circuits. The CE LVPS contains redundant low voltage power supplies and redundant motor drive regulators. Each CE LVPS powers a dedicated PE and CPM electronics. The motor drive regulators power the Drive Electronics. The Drive Electronics Assembly contains drive circuits for all motors in each Gearbox Assembly. In addition, interface circuits, sequence control, and power conditioning are contained in this assembly.

The Charged Particle Monitor Electronics Assembly includes two redundant sets of circuits for the two CPM's in the CPM subsystem. Each CPM Photomultiplier Tube (PMT) is biased by a dedicated electronics to a particular processor electronics. The Charged Particle Monitor Subsystem is inclusive in a single assembly.

FIGURE 1-2. OSSE BLOCK DIAGRAM (Fig 2-2 of EX056-007A)

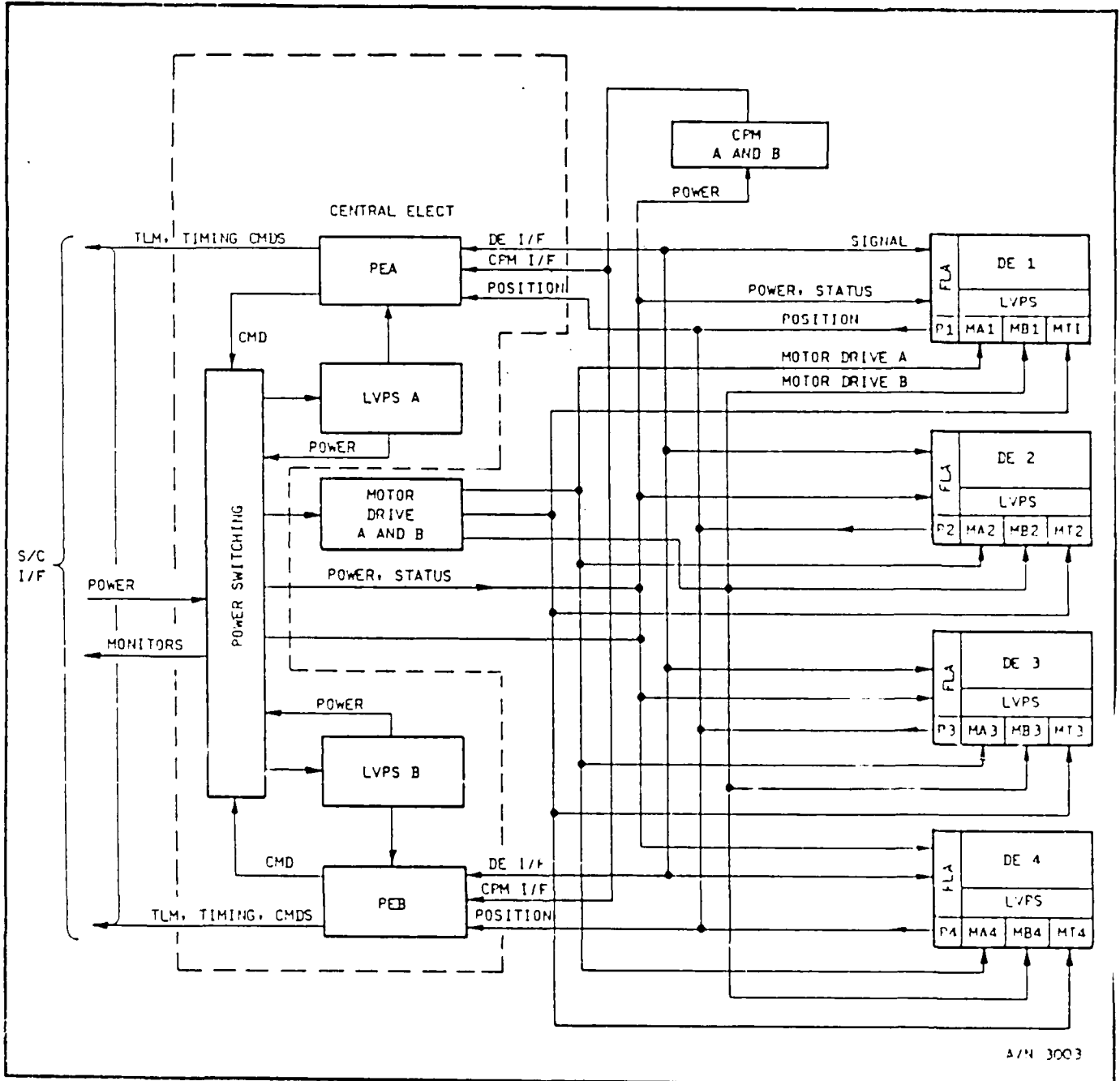

1.2 MECHANICAL OVERVIEW

The instrument consists of four large Detector Subsystems mounted on a swing-set like structure assembly. Covering or blanketing the instrument is a Thermal Shield Subsystem. The instrument arrangement is shown in Figure 1-3. Each Detector Subsystem can be rotated about its axis of rotation over a range of 192 degrees. The Detector Subsystem consists of a large crystal assembly containing a phoswich and four annulus shield scintillation crystals. In addition, there is a Charged Particle Detector (CPD) Assembly, Collimator (lead-tungsten) Assembly, Detector Electronics Assembly, Detector Mount Assembly, Magnetic Shield Assembly, and LED/PIN Diode Assembly (2). This arrangement is shown in Figure 1-3. Each scintillation element is viewed by photomultiplier tube subassemblies consisting of the phoswich (7 tubes), annular shield (4x3 tubes), charged particle detector (4 tubes), and Co60 (1 tube). This Co60 assembly is a calibration source and is part of the Collimator Assembly. The Collimator Assembly is placed forward of the phoswich in the Crystal Assembly and defines a total field of view of ± 3.8 degrees x ± 11.4 degrees. The Charged Particle Detector Assembly closely covers the forward end of the Crystal Assembly including the Collimator Assembly.

The Structure Subsystem includes the Structure Assembly and Main Cable Assembly. Mounted to the Structure Assembly are the large Central Electronics Subsystem, Drive Subsystem, and Charged Particle Monitor Subsystem as shown in Figure 1-3 (2-3). The Drive Subsystem includes four Drive Gearbox Assemblies, Drive Electronics Assembly, and Drive Cable Assembly. Each Drive Gearbox Assembly contains a 1620 to 1 gear reduction subassembly, stepper motors (2), and transfer subassembly. The transfer subassembly includes a linear actuator mechanism motor.

The Charged Particle Monitor Subsystem includes two PMT-Scintillator Assemblies, and the CPM Electronics Assembly.

The Thermal Shield Subsystem includes a Support Frame Assembly and a Thermal Blanket Assembly.

FIGURE 1-3. INSTRUMENT GENERAL ARRANGEMENT (Fig 2-3 of EX056-007A)

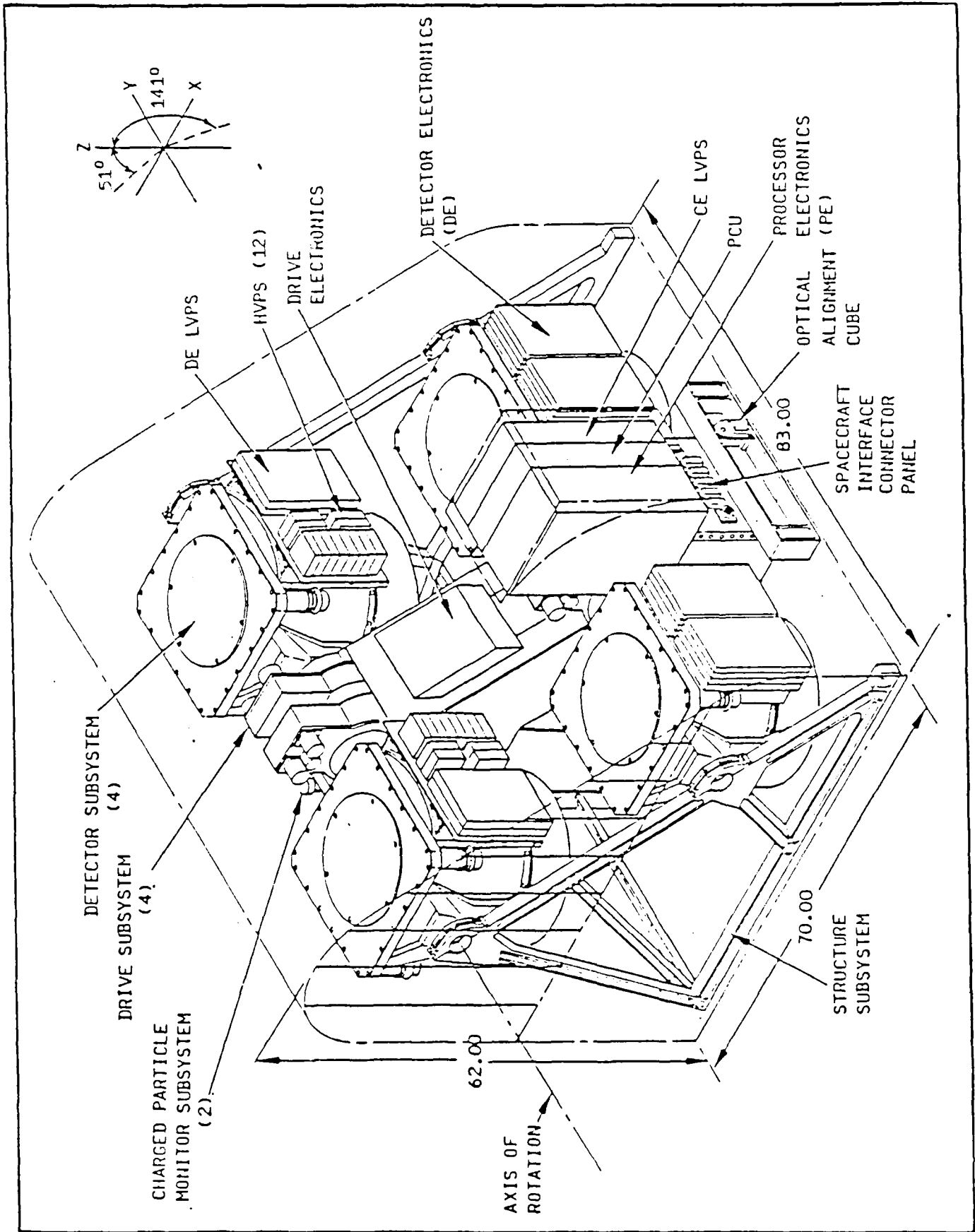
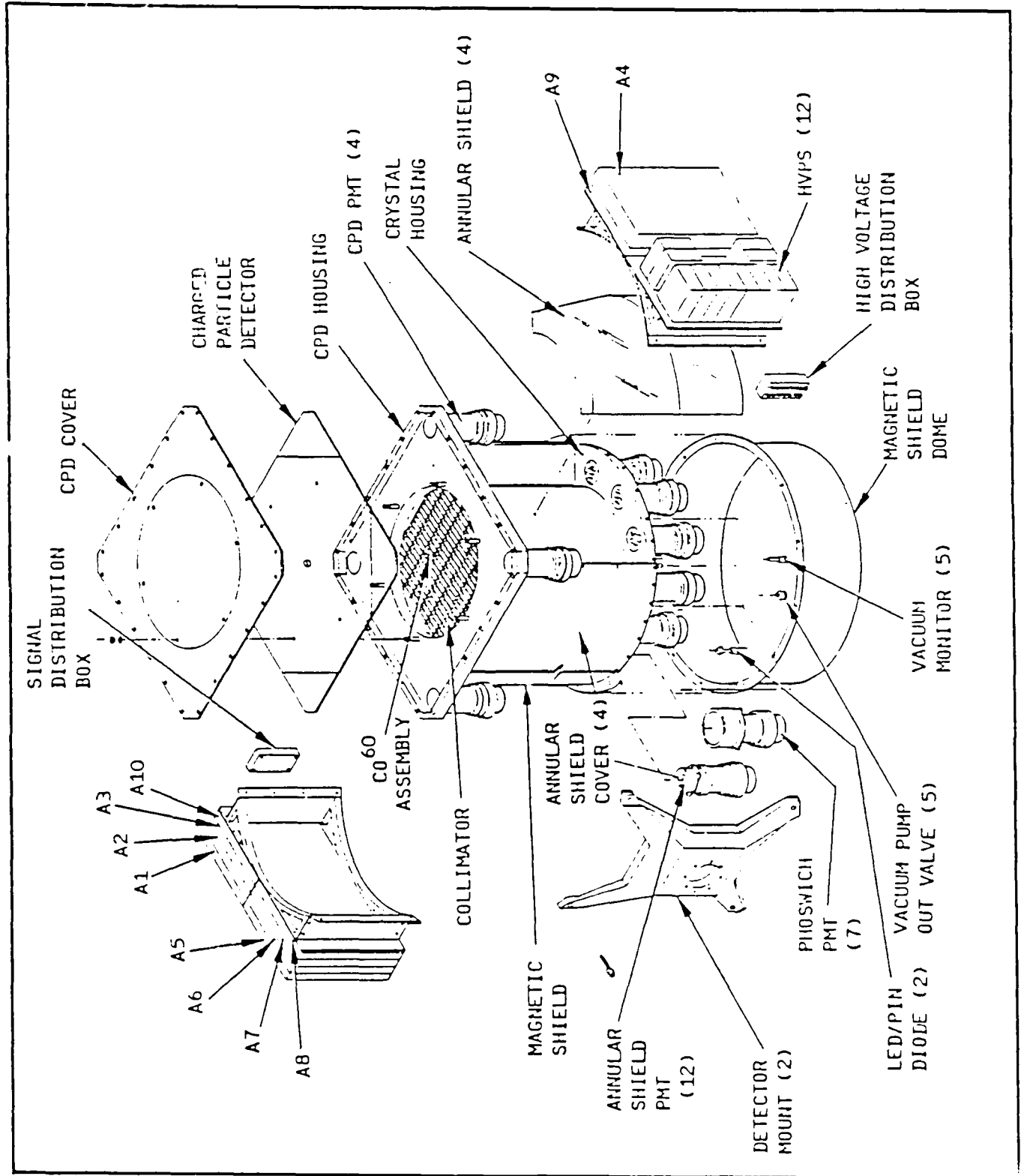

FIGURE 1-4. DETECTOR SUBSYSTEM (Fig 2-4 of EX056-007A)



1.3 SUBSYSTEMS

The subsystems described in this report are some of those systems that are pertinent to the activity of those who will work with OSSE during GRO integration. A description of a wider set of subsystems, not all of which directly affects OSSE/TRW Spacecraft integration, may be found in EX 056-007, BASD OSSE DESIGN DESCRIPTION DOCUMENT, which is included in its entirety as an appendix to this report (Appendix 1). Excerpts from that document provide the majority of material for Part 1 of this report.

1.3.1 CPM ELECTRONICS ASSEMBLY

The CPM subsystem is remotely located high on the structure providing approximately a 180 degree field of view. This subsystem includes two high voltage power supplies, two photomultiplier tubes and bleeder strings, and redundant signal processing electronics. One set of electronics is controlled by PE-A and the other by PE-B. Figures 1-5 (5-41) illustrates the CPM electronics, and Figure 1-6 (5-46) illustrates the CPM mechanical package.

1.3.2 CENTRAL ELECTRONICS CABLING

Two cabling systems are involved with the electronics and mount to the main structure. These are the main cable assembly (which is part of the structure subsystem) and the drive cable assembly (which is part of the drive subsystem). The cables are identified as W20 thru W54. Table 1-2 (5-11) is a listing of the functional use of each cable, and Figure 1-7 (5-42) is the CE cabling diagram.

FIGURE 1-5. CPM ELECTRONICS BLOCK DIAGRAM (Fig 5-41 of EX056-007A)

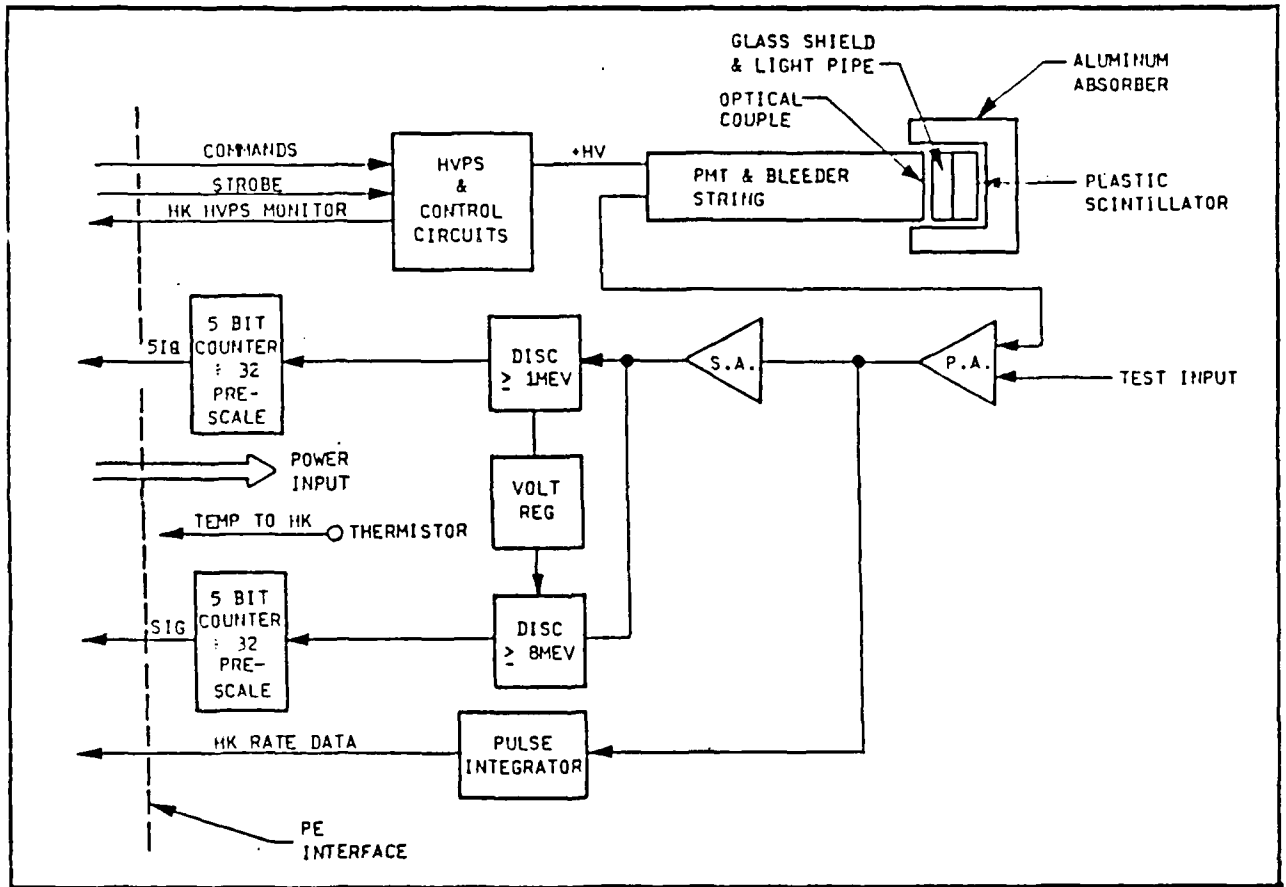

FIGURE 1-6. CPM ELECTRONICS ASSEMBLY PACKAGING (Fig 5-46 of EX056-007A)

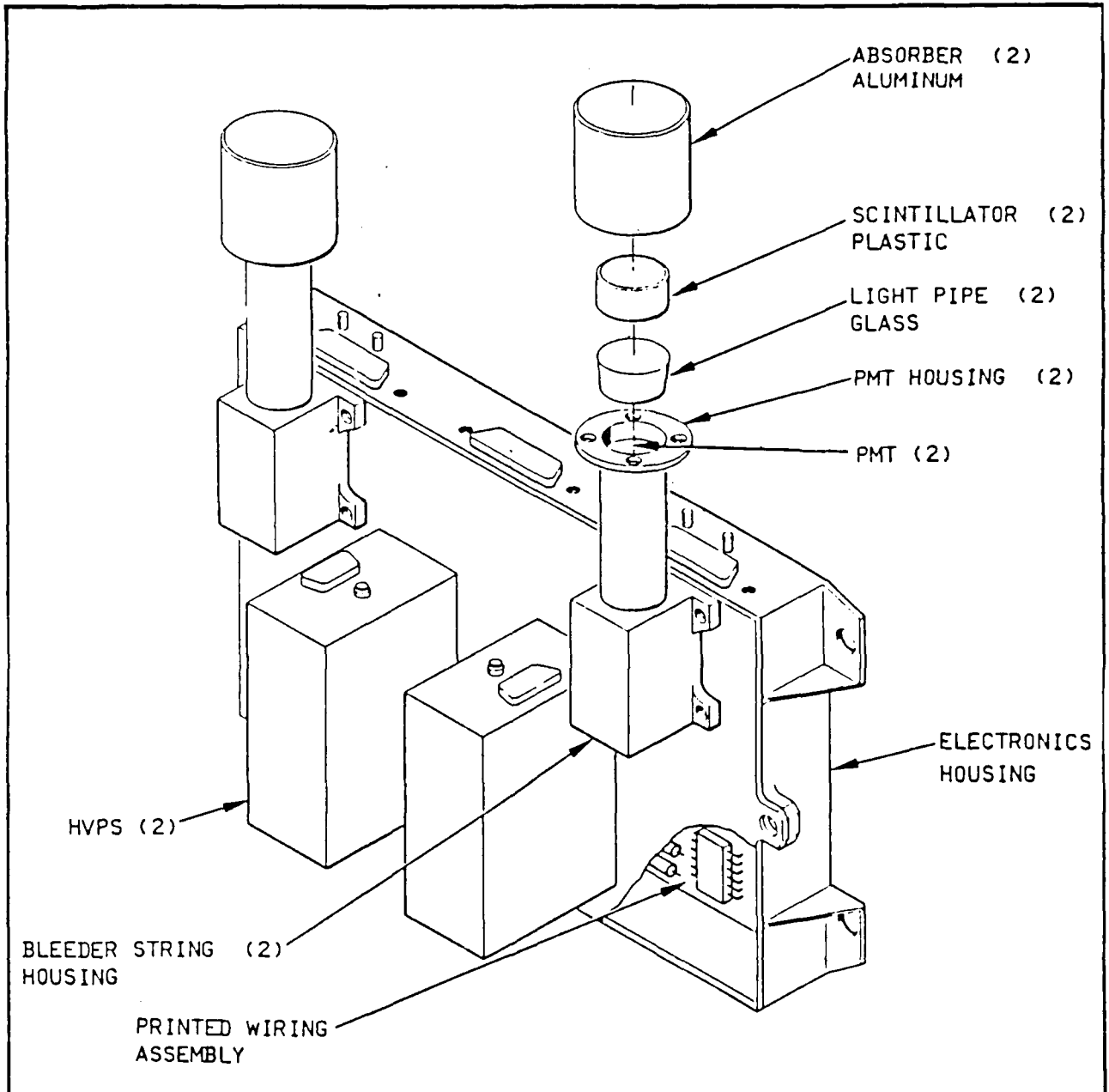
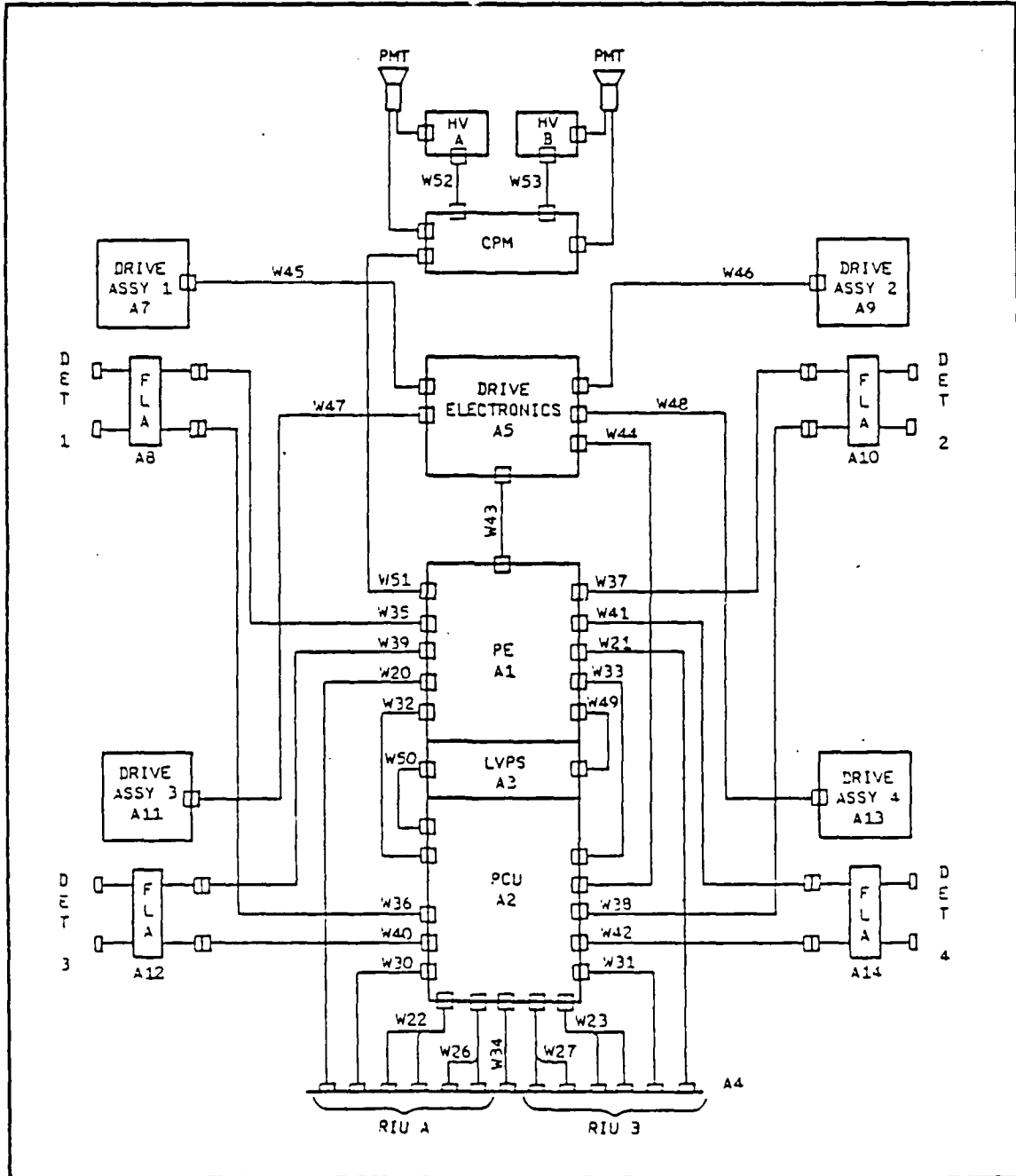

TABLE 1-2. CABLE IDENTIFICATION (Fig 5-11 of EX056-007A)

<u>Number</u>	<u>Function</u>
W20	SERIAL A
W21	SERIAL B
W22	TELEMETERY A
W23	TELEMETERY B
W24	TLM AND CLOCK A
W25	TLM AND CLOCK B
W26	DISCRETES II A
W27	DISCRETES II B
W28	DISCRETES II A
W29	DISCRETES I A
W30	MAIN POWER
W31	REDUNDANT POWER
W32	ANALOG S16 A
W33	ANALOG S16 B
W34	HEATER JUMPERS
W35	DET 1 DATA
W36	DET 1 POWER
W37	DET 2 DATA
W38	DET 2 POWER
W39	DET 3 DATA
W40	DET 3 POWER
W41	DET 4 DATA
W42	DET 4 POWER
W43	MOTOR DRIVE, SENSORS
W44	MOTOR DRIVE, TRANSFER
W45	MOTOR, LIMIT SWITCHES DET 1
W46	MOTOR, LIMIT SWITCHES DET 2
W47	MOTOR, LIMIT SWITCHES DET 3
W48	MOTOR, LIMIT SWITCHES DET 4
W49	CE POWER
W50	PE POWER
W51	CPM I/F
W52	CPM HWPS A
W53	CPM I/F
W54	HEATERS/THERMISTORS

FIGURE 1-7. CE CABLING (Fig 5-42 of EX056-007A)



1.3.3 HIGH VOLTAGE DISTRIBUTION CABLING

The High Voltage distribution is illustrated in Figure 1-8 (3-53).

1.3.4 RIU INTERFACE

The two primary RIU interfaces are both serial; one is the Command Interface and the other is the Telemetry Interface. The RIU Command Interface Block Diagram is shown in Figure 1-8, and the RIU Telemetry Interface Block Diagram is shown in Figure 1-9.

The two independent RIU Command Interfaces are supported by each processor electronics. The RIU Telemetry Interface provides the serial telemetry data interface between the spacecraft and the OSSE instrument.

1.3.5 THERMAL BUS POWER CONTROL DESCRIPTION

Figure 1-10 is a block diagram of the Thermal Bus. Both Thermal Buses, main and redundant, pass through a bus filter consisting of a two section LC filter with a balun transformer. Following the filter, each bus (power and return) is routed to four bus select relays where main or redundant power is selected by command for use by the system. The selected bus from each of the four relays had redundant 4-amp fuses with 0.25 ohm resistor in series with one of them. Voltage is monitored at this point by on/off relays which respond to discrete commands. Current from each detector active heater return is sensed by a resistor and amplifier. Status of each on/off relay position is monitored by a bilevel monitor.

1.3.6 MAKE-UP BUS POWER CONTROL DESCRIPTION

Figure 1-11 is a block diagram of the make-up bus power switching and temperature control. The main and redundant unfiltered make-up buses are routed to a single bus relay. The selected bus is then divided into five power lines. Each line is then used by the following circuits:

- DE1 Temp Control
- DE2 Temp Control
- DE3 Temp Control
- DE4 Temp Control
- CE Temp Control

Each temperature control circuit consists of redundant 3A fuses with a 0.25 ohm resistor in series with one of the fuses. A voltage monitor, a power on/off relay which responds to discrete on and off commands, and a bilevel monitor for relay on/off status are part of each circuit. Following the relay, the power line routes to a discrete temperature control circuit (thermostat) which uses a power FET for switching power to heaters located in the detector. Redundant thermistors located by the heaters provide feedback. Temperature is controlled between 10 degrees and 13.5 degrees C.

Current from each control circuit is monitored on the return line with a sense resistor and amplifier. On, off and open heater status is monitored for each circuit. The temperature control circuit has an override circuit which responds to logic level serial commands from the PE. The override command can switch the heater on at any time.

FIGURE 1-8. RIU COMMAND INTERFACE BLOCK DIAGRAM (Fig 5-14 of EX056-007A)

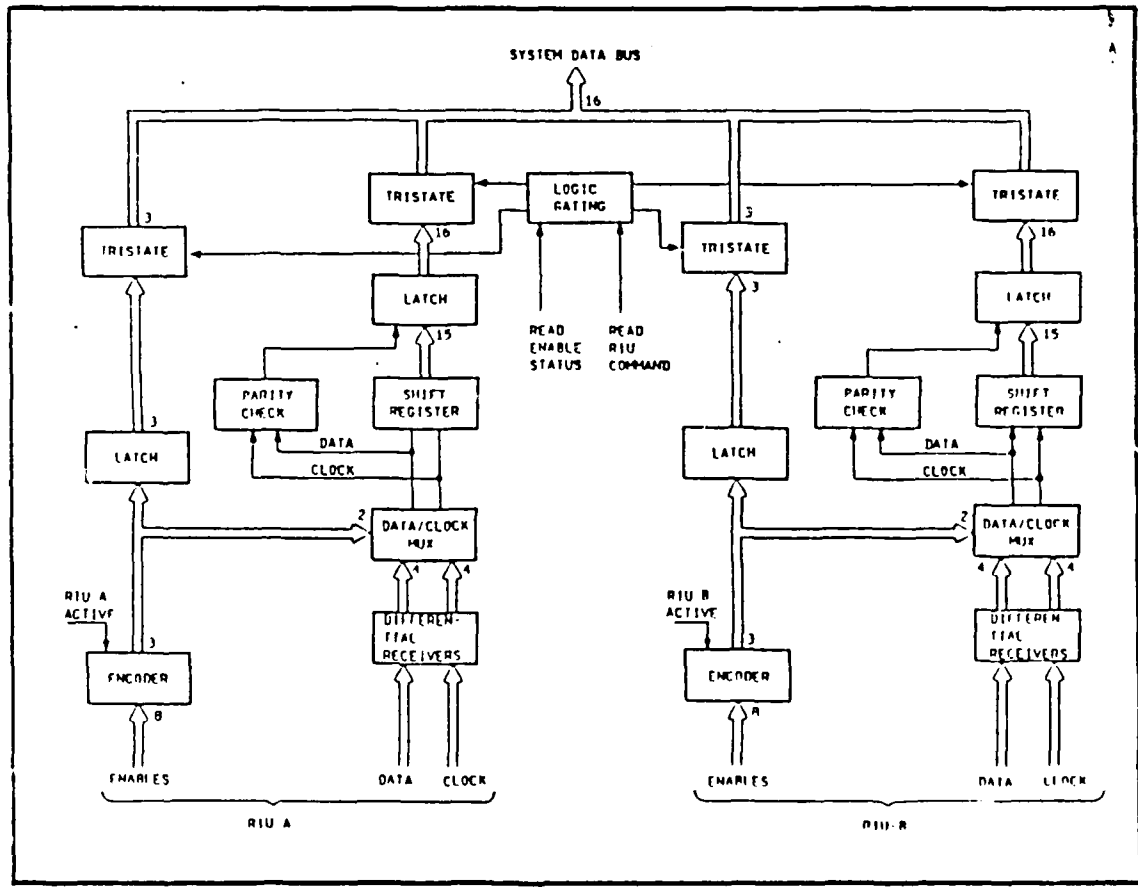

FIGURE 1-9. RIU TELEMETRY INTERFACE BLOCK DIAGRAM (Fig 5-16 of EX056-007A)

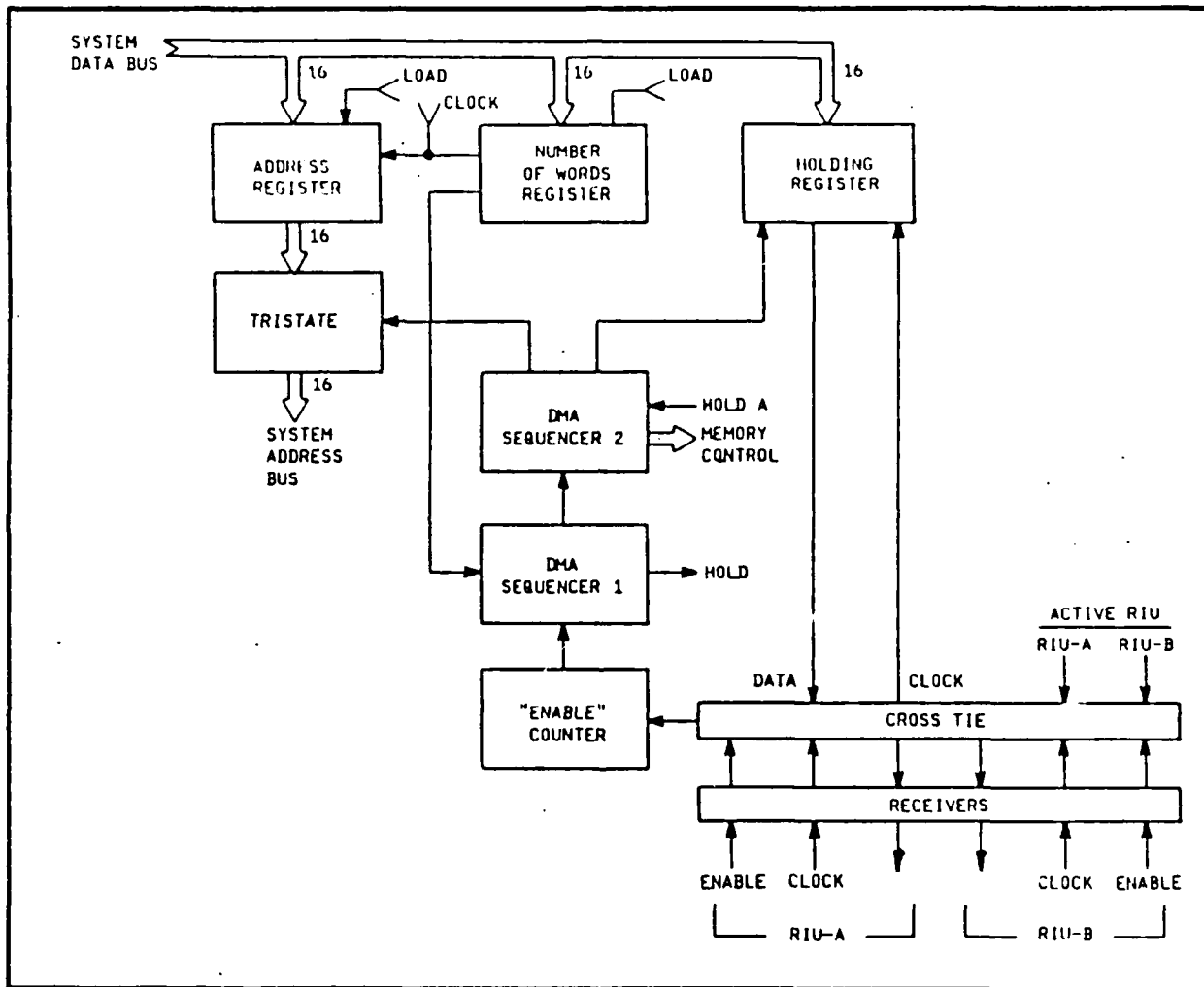

FIGURE 1-10. PCU-THERMAL BUS DETECTOR ACTIVE HEATER POWER SWITCHING
(Fig 5-33 of EX056-007A)

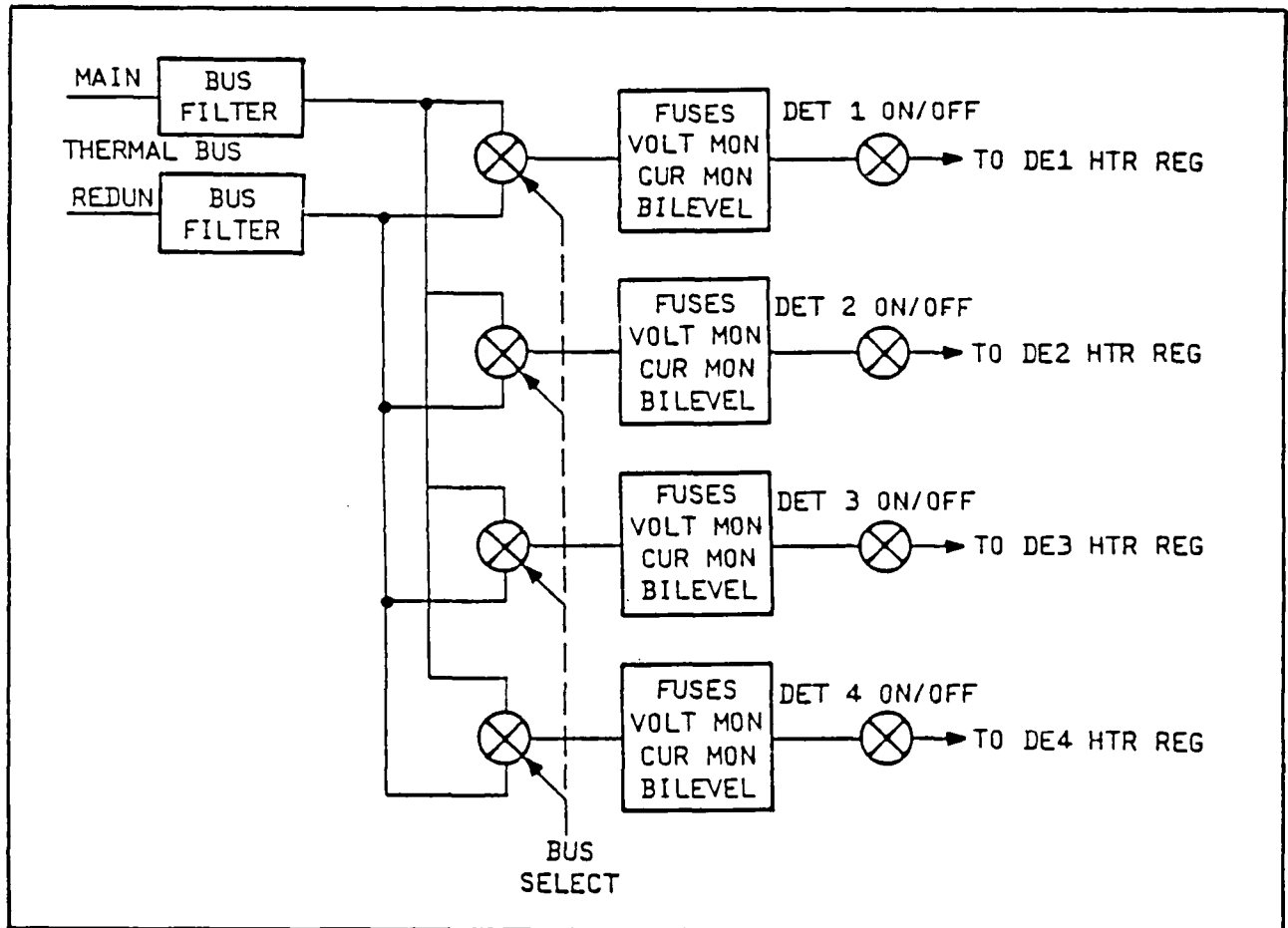
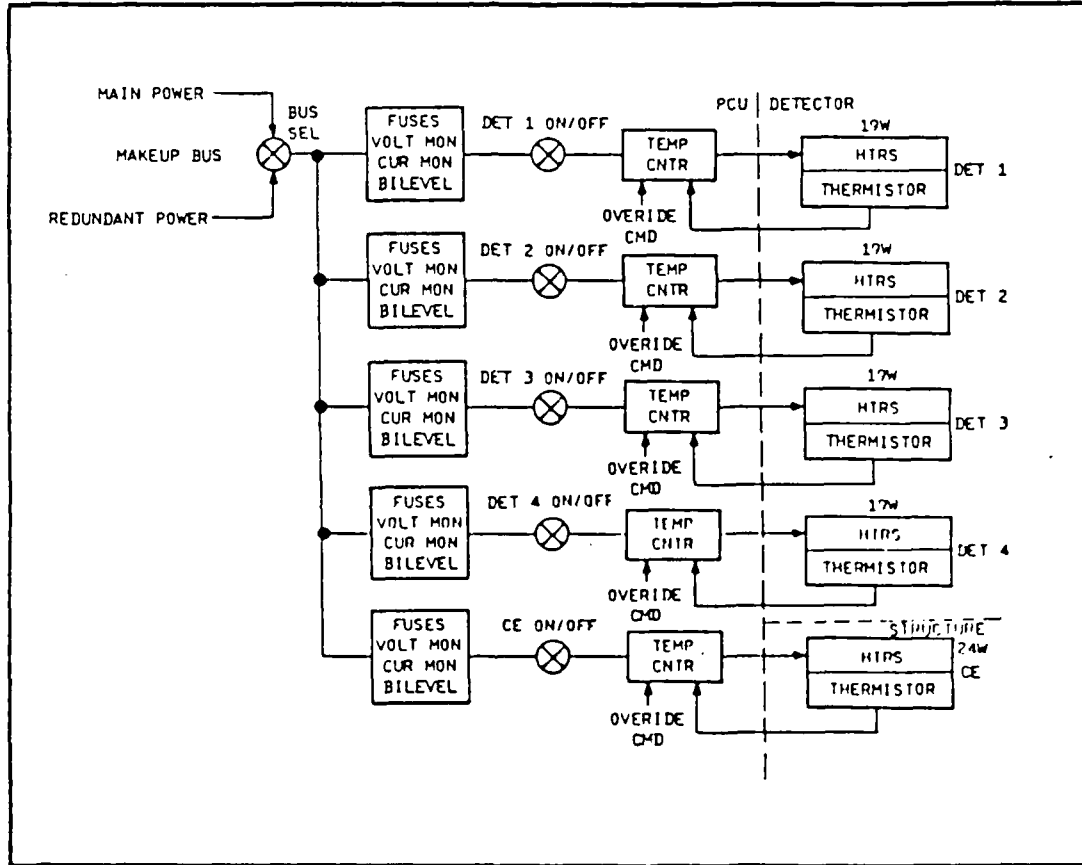

FIGURE 1-11. MAKE-UP BUS POWER SWITCHING AND TEMPERATURE CONTROL
(Fig 5-34 of EX056-007A)



PART 2. OSSE 'AS BUILT' DATA

2.1 OSSE CONNECTOR ASSIGNMENT

2.1.1 IDENTIFICATION MARKING

Each connector is identified with a unique reference designator number which was assigned by the GRO integrating contractor. Each wiring harness is identified with the manufacturer's part number, a 'w' number assigned by the integrating contractor, a serial number, and the manufacturer's name.

The TRW Document IF3-1135F, GRO SPACECRAFT/OSSE INTERFACE CONTROL DOCUMENT is referenced concerning connector pin assignments. These are described in Table 2-1, and Tables 2-2-1 through 2-2-17.

TABLE 2-1. OSSE CONNECTOR ASSIGNMENT (Table 3.2.7-1 of TRW-ICD)

INSTRUMENT SUBSYSTEM -----	INSTRUMENT CONNECTOR NO. -----	FUNCTION -----	TRW PART NO. -----
ICP*	J1	COMMANDS I, RIU-A	2A014-035V-001
ICP	J2	COMMANDS II, RIU-A	2A014-035V-001
ICP	J3	TELEMETRY, RIU-A	2A014-040V-001
ICP	J4	COMMANDS(S), RIU-A	2A014-040V-001
ICP	J5	TELEMETRY CLOCKS, RIU-A	2A014-040V-001
ICP	J6	POWER, MAIN	2A012-555V-001
ICP	J7	COMMANDS I, RIU-B	2A014-035V-001
ICP	J8	COMMANDS II, RIU-B	2A014-035V-001
ICP	J9	TELEMETRY, RIU-B	2A014-040V-001
ICP	J10	COMMANDS(S), RIU-B	2A014-040V-001
ICP	J11	TELEMETRY, CLOCKS, RIU-B	2A014-040V-001
ICP	J12	POWER, REDUNDANT	2A012-555V-001
ICP	J13	SHUTTLE IFJ	2A014-037V-001

*INTERFACE CONNECTOR PANEL (511)

TABLE 2-2-1. OSSE CONNECTOR PIN ASSIGNMENT (Table 3.2.7.2 of TRW-ICD)

OSSE/GRO INSTRUMENT INTERFACE PIN CONNECTOR ASSIGNMENTS					
ICP (511)			RIU-A (620)		

CONN NO. J1 (2A014-035V-001)					
PIN NO.	OSSE FUNCTION	GRO DESCRIPTION	PIN NO.	GRO CONN.	MODULE

1	DISC CMD +28V PULSE I	+28 VOLT PULSE I	54	J7	
2	DET 2 ACTIVE HTR ON	DISCRETE COMMAND 2	12	J7	
3	DET 4 ACTIVE HTR ON	DISCRETE COMMAND 4	10	J7	
4	DET 2 MU HTR ON	DISCRETE COMMAND 6	8	J7	
5	DET 4 MU HTR ON	DISCRETE COMMAND 8	6	J7	
6	XFER DET 2 PWR SEL A	DISCRETE COMMAND 10	34	J7	
7	XFER DET 4 PWR SEL A	DISCRETE COMMAND 12	32	J7	
8	MTR DRIVE LAUNCH LOCK OFF.	DISCRETE COMMAND 14	30	J7	
9	PROC ELECT A ON B OFF	DISCRETE COMMAND 16	28	J7	
17	SIGNAL GND	SIGNAL GND	14	J7	
18	CHASSIS GND	NC			
22	MOTOR DRIVE REG A ON B OFF	DISCRETE COMMAND 18	26	J7	
23	DET 1 MOTOR A SEL B DESEL	DISCRETE COMMAND 20	53	J7	
24	DET 3 MOTOR A SEL B DESEL	DISCRETE COMMAND 22	51	J7	
25	SPARE	DISCRETE COMMAND 24	49	J7	
26	SPARE	DISCRETE COMMAND 26	47	J7	
29	S/C MU PWR PRIM SEL	DISCRETE COMMAND 28	45	J7	
31	SEL RIUB	DISCRETE COMMAND 32	71	J7	
32	PROC ELECT B RESET	DISCRETE COMMAND 34	69	J7	
33	CHASSIS GND	NC			
34	SIGNAL GND	SIGNAL GND	12	J8	
35	S/C HTR PWR PRIM DESEL	DISCRETE COMMAND 36	67	J7	
36	S/C PRIME PWR PRIM DESEL	DISCRETE COMMAND 38	65	J7	
37	DET 4 MOTOR B SEL A DESEL	DISCRETE COMMAND 40	10	J8	
38	DET 2 MOTOR B SEL A DESEL	DISCRETE COMMAND 42	8	J8	
39	MOTOR DRIVE REG B OFF	DISCRETE COMMAND 44	6	J8	
40	PROC ELECT B OFF	DISCRETE COMMAND 46	4	J8	
41	SPARE	DISCRETE COMMAND 48	26	J8	
42	CENT ELECT MU HTR OFF	DISCRETE COMMAND 50	24	J8	
43	XFER DET 3 PWR DSPL A	DISCRETE COMMAND 52	22	J8	
44	XFER DET 1 PWR DSEL A	DISCRETE COMMAND 54	20	J8	
45	DET 3 MU HTR OFF	DISCRETE COMMAND 56	40	J8	
46	DET 1 MU HTR OFF	DISCRETE COMMAND 58	38	J8	
47	DET 3 ACTIVE HTR OFF	DISCRETE COMMAND 60	36	J8	
48	DET 1 ACTIVE HTR OFF	DISCRETE COMMAND 62	34	J8	
50	DISC CMD +28V PULSE I	+28V PULSE I	28	J8	

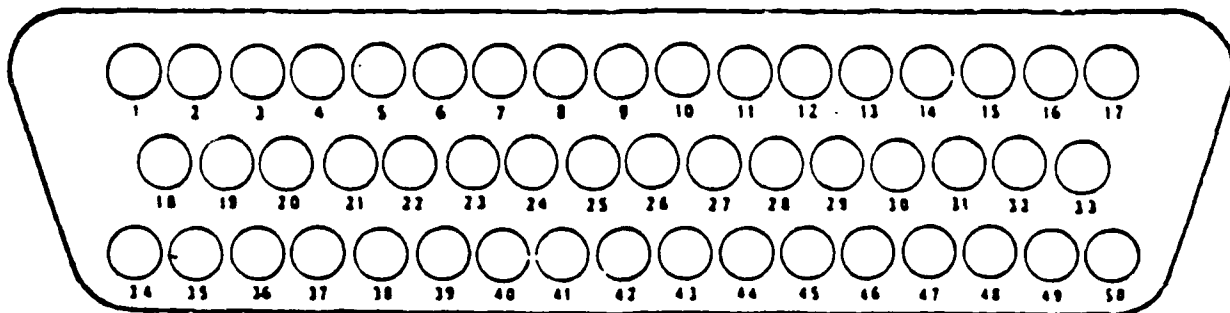

THE BOX/CHASSIS MATING/ENGAGING FACE IS SHOWN

TABLE 2-2-2. OSSE CONNECTOR PIN ASSIGNMENT (Table 3.2.7.2 of TRW-ICD, cont'd)

OSSE/GRO INSTRUMENT INTERFACE PIN CONNECTOR ASSIGNMENTS						
			ICP (511)	RIU-A (620)		

CONW NO. J2 (2A014-035V-061)						
PIN NO.	OSSE FUNCTION	GRO DESCRIPTION	PIN NO.	GRO CONW.	MODULE	
-----	-----	-----	---	---	-----	
1	DISC CMD +28V PULSE II	+28V PULSE II	35	J7		
2	DET 1 ACTIVE HTR ON	DISCRETE COMMAND 1	13	J7		
3	DET 3 ACTIVE HTR ON	DISCRETE COMMAND 3	1	J7		
4	DET 1 MU HTR ON	DISCRETE COMMAND 5	>	J7		
5	DET 3 MU HTR ON	DISCRETE COMMAND 7	7	J7		
6	XFER DET 1 PWR SEL A	DISCRETE COMMAND 9	5	J7		
7	XFER DET 3 PWR SEL A	DISCRETE COMMAND 11	33	J7		
8	CENT ELECT MU HTR ON	DISCRETE COMMAND 13	31	J7		
9	SPARE	DISCRETE COMMAND 15	29	J7		
17	SIGNAL GND	SIGNAL GND	63	J7		
18	CHASSIS GND	NC				
22	PROC ELECT B ON A OFF	DISCRETE COMMAND 17	27	J7		
23	MOTOR DRIVE REG B ON A OFF	DISCRETE COMMAND 19	25	J7		
24	DET 2 MOTOR A SEL B DESEL	DISCRETE COMMAND 21	52	J7		
25	DET 4 MOTOR A SEL B DESEL	DISCRETE COMMAND 23	50	J7		
26	DISC CMD +28V PULSE II	+28V PULSE II	11	J8		
28	S/C PRIME PWR PRIM SEL	DISCRETE COMMAND 25	48	J7		
29	S/C HTR PWR PRIM SEL	DISCRETE COMMAND 27	46	J7		
30	PROC ELECT A RESET	DISCRETE COMMAND 29	44	J7		
31	SEL RIUA	DISCRETE COMMAND 31	72	J7		
32	SPARE	DISCRETE COMMAND 33	70	J7		
33	S/C MU PWR PRIM DESEL	DISCRETE COMMAND 35	68	J7		
34	SPARE	DISCRETE COMMAND 37	66	J7		
35	SPARE	DISCRETE COMMAND 39	64	J7		
36	DET 3 MOTOR B SEL A DESEL	DISCRETE COMMAND 41	9	J8		
37	DET 1 MOTOR B SEL A DESEL	DISCRETE COMMAND 43	7	J8		
38	MOTOR DRIVE REG A OFF	DISCRETE COMMAND 45	5	J8		
39	PROC ELECT A OFF	DISCRETE COMMAND 47	3	J8		
40	CHASSIS GND	NC				
41	DISC CMD +28V PULSE III	+28V PULSE III	74	J7		
42	HTR DRIVE LAUNCH LOCK ON	DISCRETE COMMAND 49	25	J8		
43	XFER DET 4 PWR DSEL A	DISCRETE COMMAND 51	23	J8		
44	XFER DET 2 PWR DSEL A	DISCRETE COMMAND 53	21	J8		
45	DET 4 MU HTR OFF	DISCRETE COMMAND 55	19	J8		
46	DET 2 MU HTR OFF	DISCRETE COMMAND 57	39	J8		
47	DET 4 ACTIVE HTR OFF	DISCRETE COMMAND 59	37	J8		
48	DET 2 ACTIVE HTR OFF	DISCRETE COMMAND 61	35	J8		
50	DISC CMD +28V PULSE III	+28V PULSE III	27	J8		

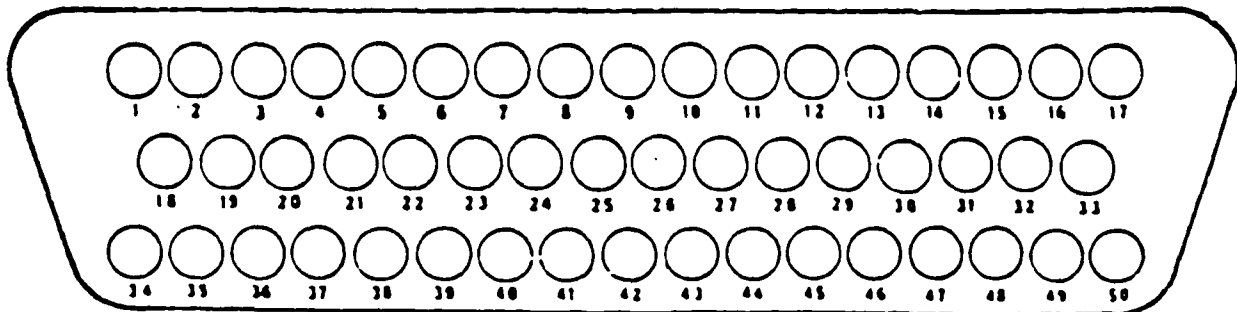

THE BOX/CHASSIS MATING/ENGAGING FACE IS SHOWN

TABLE 2-2-3. OSSE CONNECTOR PIN ASSIGNMENT (Table 3.2.7.2 of TRW-ICD, cont'd)

OSSE/GRO INSTRUMENT INTERFACE PIN CONNECTOR ASSIGNMENTS					
			ICP (511)	RIU-A (620)	

CONN NO. J3 (2A014-040V-001)					
PIN NO.	OSSE FUNCTION	GRO DESCRIPTION	PIN NO.	GRO CONN.	MODULE

1	TLM ACT ALG RTN	TLM REF INPUT 1	49	J6	
2	PEA +5V CURRENT	TLM DATA INPUT 8	41	J6	
3	PEA +10V CURRENT	TLM DATA INPUT 9	42	J6	
4	PEA -10V CURRENT	TLM DATA INPUT 10	43	J6	
5	PEA +20V CURRENT	TLM DATA INPUT 11	44	J6	
6	PEA MICRO CURRENT	TLM DATA INPUT 12	45	J6	
9	TLM ACT ALG RTN	TLM REF INPUT 1	21	J6	
10	PASS TRANS CURR RTN	PASS TRANSDUCER RTN	12	J5	
11	TLM PASS ALG RTN	TLM REF INPUT 2	33	J5	
12	DET 1 XTAL HOUS CRY 1 TEMP	TLM DATA INPUT 16	34	J5	
13	DET 2 XTAL HOUS CRY 1 TEMP	TLM DATA INPUT 17	35	J5	
14	DET 3 XTAL HOUS CRY 1 TEMP	TLM DATA INPUT 18	36	J5	
15	DET 4 XTAL HOUS CRY 1 TEMP	TLM DATA INPUT 19	37	J5	
16	SPARE	TLM DATA INPUT 20	38	J5	
17	SPARE	TLM DATA INPUT 21	39	J5	
18	SPARE	TLM DATA INPUT 22	40	J5	
19	SPARE	TLM DATA INPUT 23	41	J5	
20	TLM PASS ALG RTN	TLM REF INPUT 2	42	J5	
21	TLM PASS ALG RTN	TLM REF INPUT 3	68	J6	
22	OUTER SHELL TEMP	TLM DATA INPUT 24	60	J6	
23	STRUCTURE TEMP 1	TLM DATA INPUT 25	61	J6	
24	STRUCTURE TEMP 2	TLM DATA INPUT 26	62	J6	
27	TLM ACT ALG RTN	TLM REF INPUT 4	10	J6	
28	PEB +5V CURRENT	TLM DATA INPUT 32	11	J6	
29	PEB +10V CURRENT	TLM DATA INPUT 33	12	J6	
30	PEB -10V CURRENT	TLM DATA INPUT 34	13	J6	
31	PEB +20V CURRENT	TLM DATA INPUT 35	14	J6	
32	PEB MICRO CURRENT	TLM DATA INPUT 36	15	J6	
35	CHASSIS GND	NC			
36	TLM ACT ALG RTN	TLM REF INPUT 4	19	J6	
37	TLM ACT ALG RTN	TLM REF INPUT 5	30	J6	
38	PEA FUSE MONITOR	TLM DATA INPUT 40	31	J6	
39	PEB FUSE MONITOR	TLM DATA INPUT 41	32	J6	
40	PEA LVPS CURRENT	TLM DATA INPUT 42	33	J6	
41	PEB LVPS CURRENT	TLM DATA INPUT 43	34	J6	
45	TLM ACT ALG RTN	TLM REF INPUT 5	39	J6	
49	SIGNAL GND	SIGNAL GND	03	J5	
50	CHASSIS GND	NC			

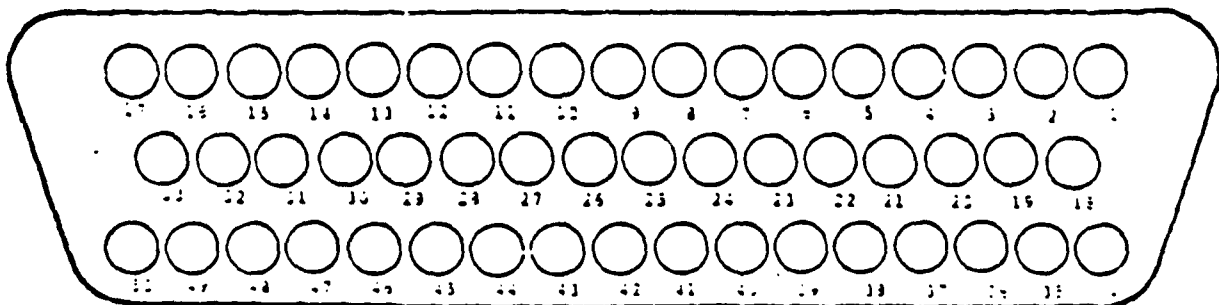

THE BOX/CHASSIS MATING/ENGAGING FACE IS SHOWN

TABLE 2-2-4. OSSE CONNECTOR PIN ASSIGNMENT (Table 3.2.7.2 of TRW-ICD, cont'd)

		OSSE/GRO				
		INSTRUMENT INTERFACE PIN CONNECTOR ASSIGNMENTS				
		ICP (511)		RIU-A (620)		

CONN NO. J4 (2A014-040V-001)						

PIN NO.	OSSE FUNCTION	GRO DESCRIPTION	PIN NO.	GRO CONN.	MODULE	
-----	-----	-----	-----	-----	-----	-----
1	SER CMD CLK 1 TRUE	SER CMD CLK 1 TRUE	39	J7		
2	SER CMD CLK 1 COMP	SER CMD CLK 1 COMP	38	J7		
3	SER CMD CLK 2 TRUE	SER CMD CLK 2 TRUE	58	J7		
4	SER CMD CLK 2 COMP	SER CMD CLK 2 COMP	57	J7		
5	SER CMD CLK 3 TRUE	SER CMD CLK 3 TRUE	78	J7		
6	SER CMD CLK 3 COMP	SER CMD CLK 3 COMP	77	J7		
7	SER CMD CLK 4 TRUE	SER CMD CLK 4 TRUE	44	J8		
8	SER CMD CLK 4 COMP	SER CMD CLK 4 COMP	43	J8		
9	SER DATA CLK 1 TRUE	SER DATA CLK 1 TRUE	1	J5		
10	SER DATA CLK 1 COMP	SER DATA CLK 1 COMP	2	J5		
11	CHASSIS GND	NC				
12	SIGNAL GND	SIGNAL GND	3	J5		
13	MAJOR FRAME RATE SIG 3	MAJOR FRAME RATE 3	60	J7		
14	1.024 MHZ CLK 2 TRUE	1.024 MHZ CLK 2 TRUE	1	J8		
15	1.024 MHZ CLK 2 COMP	1.024 MHZ CLK 2 COMP	17	J8		
16	CONDITIONED +5.3 STBY II-3	+5.3V STBY II-3	44	J5	RIU-B(621)	
17	BATSE TRIG SIG-MAIN	BTS-A, PRIME	22	J39	CEU-A(551)	
18	SER CMD DATA 1 TRUE	SER CMD DATA 1 TRUE	37	J7		
19	SER CMD DATA 1 COMP	SER CMD DATA 1 COMP	36	J7		
20	SER CMD DATA 2 TRUE	SER CMD DATA 2 TRUE	56	J7		
21	SER CMD DATA 2 COMP	SER CMD DATA 2 COMP	55	J7		
22	SER CMD DATA 3 TRUE	SER CMD DATA 3 TRUE	76	J7		
23	SER CMD DATA 3 COMP	SER CMD DATA 3 COMP	75	J7		
24	SER CMD DATA 4 TRUE	SER CMD DATA 4 TRUE	30	J8		
25	SER CMD DATA 4 COMP	SER CMD DATA 4 COMP	29	J8		
26	SER DATA CLK 3 TRUE	SER DATA CLK 3 TRUE	3	J6		
27	SER DATA CLK 3 COMP	SER DATA CLK 3 COMP	4	J6		
28	CHASSIS GND	NC				
29	SIGNAL GND	SIGNAL GND	2	J6		
30	MAJOR FRAME RATE 4	MAJOR FRAME RATE 4	32	J8		

TABLE 2-2-5. OSSE CONNECTOR PIN ASSIGNMENT (Table 3.2.7.2 of TRW-ICD, cont'd)

OSSE/GRO INSTRUMENT INTERFACE PIN CONNECTOR ASSIGNMENTS						
ICP (511)			RIU-A (620)			
CONN NO. J4 (2A014-040V-001)						
PIN NO.	OSSE FUNCTION	GRO DESCRIPTION	PIN NO.	GRO CONN.	MODULE	
31	1.024 MHZ CLK 1 TRUE	1.024 MHZ CLK 1 TRUE	3	J7		
32	1.024 MHZ CLK 1 COMP	1.024 MHZ CLK 1 COMP	2	J7		
33	CONDITIONED +5.3V STBY II-2	+5.3V STBY II-2	43	J5		
34	BATSE TRIG SIG RTN-MAIN	BTS-A RTN, PRIME	23	J39	CEU-A(551)	
35	SER CMD EN 0 (UTC)	SER CMD ENABLE 0 (UTC)	20	J7		
36	SER CMD EN 1	SER CMD ENABLE 1	19	J7		
37	SER CMD EN 2	SER CMD ENABLE 2	18	J7		
38	SER CMD EN 3	SER CMD ENABLE 3	17	J7		
39	SER CMD EN 4	SER CMD ENABLE 4	16	J7		
40	SER CMD EN 5	SER CMD ENABLE 5	15	J7		
41	SER CMD EN 6	SER CMD ENABLE 6	14	J8		
42	SER CMD EN 7	SER CMD ENABLE 7	13	J8		
43	SIGNAL GND	SIGNAL GND	43	J7		
44	TLM DATA I/P 0	TLM DATA INPUT 0	20	J5		
45	TLM REP I/P 0	TLM REP INPUT 0	19	J5		
46	SER/AUX TLM EN 0	SER/AUX ENABLE 0	4	J5		
47	CONDITIONED +5.3V STBY II-1	+5.3V STBY II-1	32	J5		
48	1 HZ TIMING SIG TRUE,MAIN	TTU 1.0 HZ,TRUE,MAIN	7	J105	CADR(601)	
49	1 HZ TIMING SIG COMP,MAIN	TTU 1.0 HZ,COMP,MAIN	20	J105	CADR(601)	
50	BATSE TRIG SIG SHLD,MAIN	BTS SHLD,MAIN	NC		CEU-A(551)	

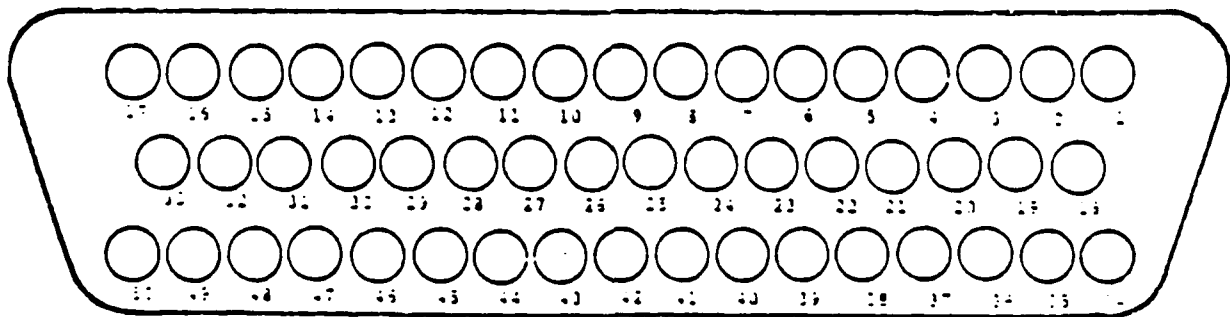

THE BOX/CHASSIS MATING/ENGAGING FACE IS SHOWN

TABLE 2-2-6. OSSE CONNECTOR PIN ASSIGNMENT (Table 3.2.7.2 of TRW-ICD, cont'd)

OSSE/GRO INSTRUMENT INTERFACE PIN CONNECTOR ASSIGNMENTS					
ICP (511)			RIU-A (620)		
CONN NO. J5 (2A014-040V-001)					
PIN NO.	OSSE FUNCTION	GRO DESCRIPTION	PIN NO.	GRO CONN.	MODULE
1	TLM ACT ALG RTN	TLM REF INPUT 6	50	J6	
2	DET 1 ACTIVE HTR CURRENT	TLM DATA INPUT 52	55	J6	
3	DET 2 ACTIVE HTR CURRENT	TLM DATA INPUT 53	56	J6	
4	DET 3 ACTIVE HTR CURRENT	TLM DATA INPUT 54	57	J6	
5	DET 4 ACTIVE HTR CURRENT	TLM DATA INPUT 55	58	J6	
6	TLM ACT ALG RTN	TLM REF INPUT 6	59	J6	
7	TLM ACT ALG RTN	TLM REF INPUT 7	69	J6	
8	DET 1 MAKEUP MONITOR	TLM DATA INPUT 56	70	J6	
9	DET 2 MAKEUP MONITOR	TLM DATA INPUT 57	71	J6	
10	DET 3 MAKEUP MONITOR	TLM DATA INPUT 58	72	J6	
11	DET 4 MAKEUP MONITOR	TLM DATA INPUT 59	73	J6	
12	CE MAKEUP HTR MONITOR	TLM DATA INPUT 60	74	J6	
13	TLM ACT ALG RTN	TLM REF INPUT 7	78	J6	
14	TLM BILEVEL RTN	TLM REF INPUT 0	19	J2	EU (622)
15	DET 1 ACTIVE HTR ON/OFF	TLM DATA INPUT 0	20	J2	EU (622)
16	DET 2 ACTIVE HTR ON/OFF	TLM DATA INPUT 1	21	J2	EU (622)
17	DET 3 ACTIVE HTR ON/OFF	TLM DATA INPUT 2	22	J2	EU (622)
18	DET 4 ACTIVE HTR ON/OFF	TLM DATA INPUT 3	23	J2	EU (622)
23	TLM BILEVEL RTN	TLM REF INPUT 0	28	J2	EU (622)
24	TLM ACT ALG RTN	TLM REF INPUT 4	10	J3	EU (622)
25	STS HTR TEST PT DET 1	TLM DATA INPUT 32	11	J3	EU (622)
26	STS HTR TEST PT DET 2	TLM DATA INPUT 33	12	J3	EU (622)
27	STS HTR TEST PT DET 3	TLM DATA INPUT 34	13	J3	EU (622)
28	STS HTR TEST PT DET 4	TLM DATA INPUT 35	14	J3	EU (622)
29	STS HTR TEST PT DPT PE	TLM DATA INPUT 36	15	J3	EU (622)
30	TLM ACT ALG RTN	TLM REF INPUT 4	19	J3	EU (622)
31	TLM BILEVEL RTN	TLM REF INPUT 5	30	J3	EU (622)
32	RIU-B SELECTED	TLM DATA INPUT 40	31	J3	EU (622)
33	S/C PRIME PWR-PRIM SELECT	TLM DATA INPUT 41	32	J3	EU (622)
35	S/C HTR PWR-PRIM SELECT	TLM DATA INPUT 43	34	J3	EU (622)

TABLE 2-2-7. OSSE CONNECTOR PIN ASSIGNMENT (Table 3.2.7.2 of TRW-ICD, cont'd)

OSSE/GRO INSTRUMENT INTERFACE PIN CONNECTOR ASSIGNMENTS					
ICP (511)			RIU-A (620)		
CONN NO. J5 (2A014-040V-001)					
PIN NO.	OSSE FUNCTION	GRO DESCRIPTION	PIN NO.	GRO CONN.	MODULE
36	S/C MAKEUP PWR-PRIM SELECT	TLM DATA INPUT 44	35	J3	EU (622)
37	TLM BILEVEL RTN	TLM REP INPUT 5	39	J3	EU (622)
38	TLM BILEVEL RTN	TLM REP INPUT 1	21	J3	EU (622)
39	PEA ON/OFF	TLM DATA INPUT 8	41	J3	EU (622)
40	PEB ON/OFF	TLM DATA INPUT 9	42	J3	EU (622)
41	CE MAKEUP ON/OFF	TLM DATA INPUT 10	43	J3	EU (622)
42	DET 1 MAKEUP ON/OFF	TLM DATA INPUT 11	44	J3	EU (622)
43	DET 2 MAKEUP ON/OFF	TLM DATA INPUT 12	45	J3	EU (622)
44	DET 3 MAKEUP ON/OFF	TLM DATA INPUT 13	46	J3	EU (622)
45	DET 4 MAKEUP ON/OFF	TLM DATA INPUT 14	47	J3	EU (622)
46	RIU-A SELECTED	TLM DATA INPUT 15	48	J3	EU (622)
47	TLM BILEVEL RTN	TLM REP INPUT 1	49	J3	EU (622)
50	CHASSIS GND	NC			

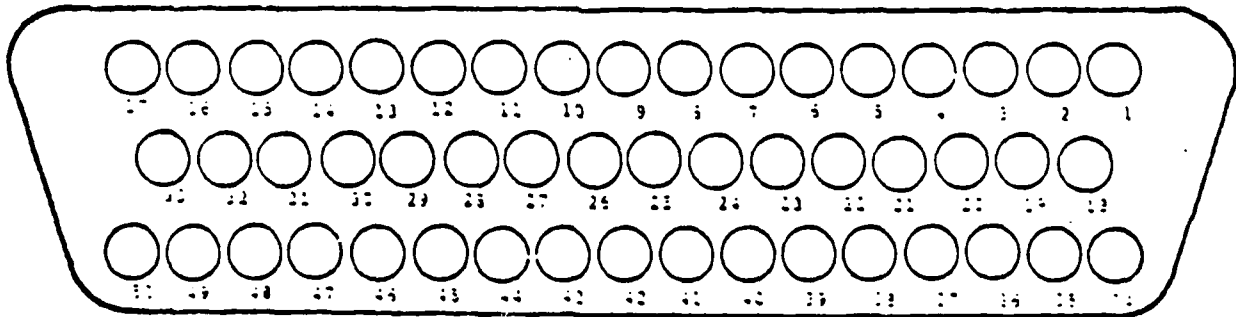

THE BOX/CHASSIS MATING/ENGAGING FACE IS SHOWN

TABLE 2-2-8. OSSE CONNECTOR PIN ASSIGNMENT (Table 3.2.7.2 of TRW-ICD, cont'd)

OSSE/GRO INSTRUMENT INTERFACE PIN CONNECTOR ASSIGNMENTS						
ICP (511)			ISU (402)			

CONN NO. J6 (2A012-555V-001)						

PIN NO.	OSSE FUNCTION	GRO DESCRIPTION	PIN NO.	GRO CONN.	MODULE	

A	+28V QUIET,MAIN	INSTR PWR (PRIM)				
B	+28V QUIET,MAIN	INSTR PWR (PRIM)				
B	+28V QUIET,MAIN	INSTR PWR (PRIM)				
B	+28V QUIET,MAIN	INSTR PWR (PRIM)				
D	+28V QUIET RTN,MAIN	INSTR PWR RTN (PRIM)				
E	+28V THER,MAIN	T/C HTR PWR (PRIM)				
F	+28V THER,MAIN	T/C HTR PWR (PRIM)				
G	+28V THER RTN,MAIN	T/C HTR PWR RTN (PRIM)				
H	+28V THER RTN,MAIN	T/C HTR PWR RTN (PRIM)				
J	+28V MAKEUP,MAIN	M/U HTR PWR (PRIM)				
K	+28V MAKEUP,MAIN	M/U HTR PWR (PRIM)				
L	+28V MAKEUP RTN,MAIN	M/U HTR PWR RTN (PRIM)				
M	+28V MAKEUP RTN,MAIN	M/U HTR PWR RTN (PRIM)				
N	+28V SHUTTLE OPS	STS HTR PWR	J02		UICB*(102)	
P	+28V SHUTTLE OPS	STS HTR PWR	J02		UICB (102)	
R	+28V QUIET, MAIN	INSTR PWR (PRIM)				
S	+28V QUIET, MAIN RTN	INSTR PWR RTN (PRIM)				
T	+28V SHUTTLE OPS RTN	STS HTR PWR RTN	J02		UICB (102)	
U	+28V SHUTTLE OPS RTN	STS HTR PWR RTN	J02		UICB (102)	
V	+28V SHUTTLE OPS RTN	STS HTR PWR RTN	J02		UICB (102)	
W	+28V SHUTTLE OPS	STS HTR PWR	J02		UICB (102)	
X	CHASSIS GND	NC				

* UMBILICAL INTERFACE CONNECTOR BRACKET

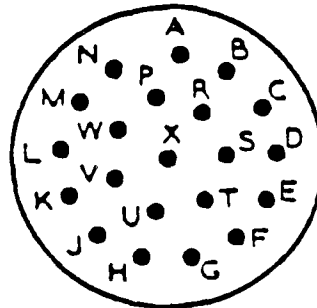

THE BOX/CHASSIS MATING/ENGAGING FACE IS SHOWN

TABLE 2-2-9. OSSE CONNECTOR PIN ASSIGNMENT (Table 3.2.7.2 of TRW-ICD, cont'd)

OSSE/GRO INSTRUMENT INTERFACE PIN CONNECTOR ASSIGNMENTS						
ICP (511)			RIU-B (621)			

CONN NO. J7 (2A014-035V-001)						
PIN NO.	OSSE FUNCTION	GRO DESCRIPTION	PIN NO.	GRO CONN.	MODULE	
-----	-----	-----	-----	-----	-----	
1	DISC CMD +28V PULSE I	+28V PULSE I	54	J7		
2	DET 2 ACTIVE HTR ON	DISCRETE COMMAND 2	12	J7		
3	DET 4 ACTIVE HTR ON	DISCRETE COMMAND 4	10	J7		
4	DET 2 MU HTR ON	DISCRETE COMMAND 6	8	J7		
5	DET 4 MU HTR ON	DISCRETE COMMAND 8	6	J7		
6	XPER DET 2 PWR SEL A	DISCRETE COMMAND 10	34	J7		
7	XPER DET 4 PWR SEL A	DISCRETE COMMAND 12	32	J7		
8	MTR DRIVE LAUNCH LOCK OFF	DISCRETE COMMAND 14	30	J7		
9	PROC ELECT A ON B OFF	DISCRETE COMMAND 16	28	J7		
17	SIGNAL GND	SIGNAL GND	14	J7		
18	CHASSIS GND	NC				
22	MOTOR DRIVE REG A ON B OFF	DISCRETE COMMAND 18	26	J7		
23	DET 1 MOTOR A SEL B DESEL	DISCRETE COMMAND 20	53	J7		
24	DET 3 MOTOR A SEL B DESEL	DISCRETE COMMAND 22	51	J7		
25	SPARE	DISCRETE COMMAND 24	49	J7		
26	SPARE	DISCRETE COMMAND 26	47	J7		
29	S/C MU PWR PRIM SEL	DISCRETE COMMAND 28	45	J7		
31	SEL RIUB	DISCRETE COMMAND 32	71	J7		
32	PROC ELECT B RESET	DISCRETE COMMAND 34	69	J7		
33	CHASSIS GND	NC				
34	SIGNAL GND	SIGNAL GND	12	J8		
35	S/C HTR PWR PRIM DESEL	DISCRETE COMMAND 36	67	J7		
36	S/C PRI PWR PRIM DESEL	DISCRETE COMMAND 38	65	J7		
37	DET 4 MOTOR B SEL A DESEL	DISCRETE COMMAND 40	10	J8		
38	DET 2 MOTOR B SEL A DESEL	DISCRETE COMMAND 42	8	J8		
39	MOTOR DRIVE REG B OFF	DISCRETE COMMAND 44	6	J8		
40	PROC ELECT B OFF	DISCRETE COMMAND 46	4	J8		
41	SPARE	DISCRETE COMMAND 48	26	J8		
42	CENT ELECT MU HTR OFF	DISCRETE COMMAND 50	24	J8		
43	XPER DET 3 PWR DSEL A	DISCRETE COMMAND 52	22	J8		
44	XPER DET 1 PWR DSEL A	DISCRETE COMMAND 54	20	J8		
45	DET 3 MU HTR OFF	DISCRETE COMMAND 56	40	J8		
46	DET 1 MU HTR OFF	DISCRETE COMMAND 58	38	J8		
47	DET 3 ACTIVE HTR OFF	DISCRETE COMMAND 60	36	J8		
48	DET 1 ACTIVE HTR OFF	DISCRETE COMMAND 62	34	J8		
50	DISC CMD +28V PULSE I	+28V PULSE I	28	J8		

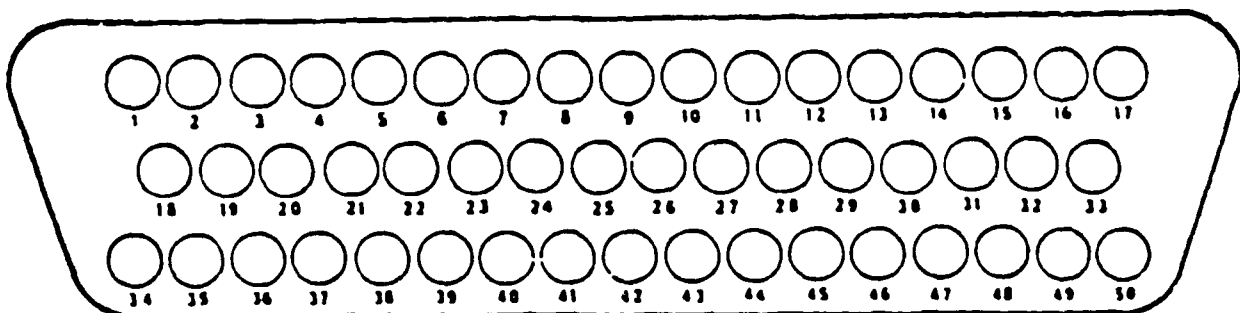

THE BOX/CHASSIS MATING/ENGAGING FACE IS SHOWN

TABLE 2-2-10. OSSE CONNECTOR PIN ASSIGNMENT (Table 3.2.7.2 of TRW-ICD, cont'd)

OSSE/GRO INSTRUMENT INTERFACE PIN CONNECTOR ASSIGNMENTS					
ICP (511)			RIU-B (621)		

CONN NO. J8 (2A014-035V-001)					
PIN NO.	OSSE FUNCTION	GRO DESCRIPTION	PIN NO.	GRO CONN.	MODULE
-----	-----	-----	-----	-----	-----
1	DISC CMD +28V PULSE II	+28V PULSE II	35	J7	
2	DET 1 ACTIVE HTR ON	DISCRETE COMMAND 1	13	J7	
3	DET 3 ACTIVE HTR ON	DISCRETE COMMAND 3	11	J7	
4	DET 1 MU HTR ON	DISCRETE COMMAND 5	9	J7	
5	DET 3 MU HTR ON	DISCRETE COMMAND 7	7	J7	
6	XFER DET 1 PWR SEL A	DISCRETE COMMAND 9	5	J7	
7	XFER DET 3 PWR SEL A	DISCRETE COMMAND 11	33	J7	
8	CENT ELECT MU HTR ON	DISCRETE COMMAND 13	31	J7	
9	SPARE	DISCRETE COMMAND 15	29	J7	
17	SIGNAL GND	SIGNAL GND	63	J7	
18	CHASSIS GND	NC			
22	PROC ELECT B ON A OFF	DISCRETE COMMAND 17	27	J7	
23	MOTOR DRIVE REG B ON A OFF	DISCRETE COMMAND 19	25	J7	
24	DET 2 MOTOR A SEL B DESEL	DISCRETE COMMAND 21	52	J7	
25	DET 4 MOTOR A SEL B DESEL	DISCRETE COMMAND 23	50	J7	
26	DISC CMD +28V PULSE II	+28V PULSE II	11	J8	
28	S/C PRIME PWR PRIM SEL	DISCRETE COMMAND 25	48	J7	
29	S/C HTR PWR PRIM SEL	DISCRETE COMMAND 27	46	J7	
30	PROC ELECT A RESET	DISCRETE COMMAND 29	44	J7	
31	SEL RIUA	DISCRETE COMMAND 31	72	J7	
32	SPARE	DISCRETE COMMAND 33	70	J7	
33	S/C MU PWR PRIM DESEL	DISCRETE COMMAND 35	68	J7	
34	SPARE	DISCRETE COMMAND 37	66	J7	
35	SPARE	DISCRETE COMMAND 39	64	J7	
36	DET 3 MOTOR B SEL A DESEL	DISCRETE COMMAND 41	9	J8	
37	DET 1 MOTOR B SEL A DESEL	DISCRETE COMMAND 43	7	J8	
38	MOTOR DRIVE REG A OFF	DISCRETE COMMAND 45	5	J8	
39	PROC ELECT A OFF	DISCRETE COMMAND 47	3	J8	
40	CHASSIS GND	NC			
41	DISC CMD +28V PULSE III	+28V PULSE III	74	J7	
42	HTR DRIVE LAUNCH LOCK ON	DISCRETE COMMAND 49	25	J8	
43	XFER DET 4 PWR DSEL A	DISCRETE COMMAND 51	23	J8	
44	XFER DET 2 PWR DSEL A	DISCRETE COMMAND 53	21	J8	
45	DET 4 MU HTR OFF	DISCRETE COMMAND 55	19	J8	
46	DET 2 MU HTR OFF	DISCRETE COMMAND 57	17	J8	
47	DET 4 ACTIVE HTR OFF	DISCRETE COMMAND 59	15	J8	
48	DET 2 ACTIVE HTR OFF	DISCRETE COMMAND 61	13	J8	
50	DISC CMD +28V PULSE III	+28V PULSE III	27	J8	

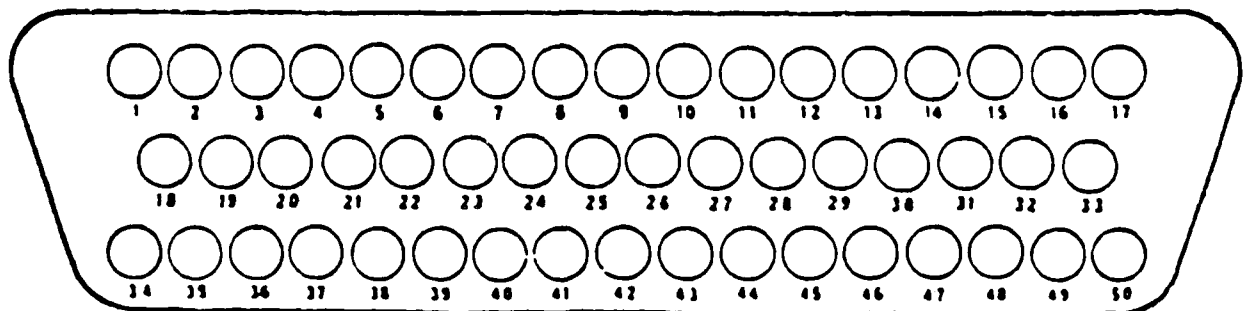

THE BOX/CHASSIS MATING/ENGAGING FACE IS SHOWN

TABLE 2-2-11. OSSE CONNECTOR PIN ASSIGNMENT (Table 3.2.7.2 of TRW-ICD, cont'd)

OSSE/GRO INSTRUMENT INTERFACE PIN CONNECTOR ASSIGNMENTS						
ICP (511)			RIU-B (621)			
CONN NO. J9 (2A014-040V-001)						
PIN NO.	OSSE FUNCTION	GRO DESCRIPTION	PIN NO.	GRO CONN.	MODULE	
1	TLM ACT ALG RTN	TLM REF INPUT 1	49	J6		
2	PEA +5V CURRENT	TLM DATA INPUT 8	41	J6		
3	PEA +10V CURRENT	TLM DATA 9	42	J6		
4	PEA -10V CURRENT	TLM DATA INPUT 10	43	J6		
5	PEA +20V CURRENT	TLM DATA INPUT 11	44	J6		
6	PEA MICRO CURRENT	TLM DATA INPUT 12	45	J6		
9	TLM ACT ALG RTN	TLM REF INPUT 1	21	J6		
10	PASS TRANS CURR RTN	PASS TRANSDUCER RTN	12	J5		
11	TLM PASS ALG RTN	TLM REF INPUT 2	33	J5		
12	DET 1 XTAL HOUS CRY 2 TEMP	TLM DATA INPUT 16	34	J5		
13	DET 2 XTAL HOUS CRY 2 TEMP	TLM DATA INPUT 17	35	J5		
14	DET 3 XTAL HOUS CRY 2 TEMP	TLM DATA INPUT 18	36	J5		
15	DET 4 XTAL HOUS CRY 2 TEMP	TLM DATA INPUT 19	37	J5		
16	SPARE	TLM DATA INPUT 20	38	J5		
17	SPARE	TLM DATA INPUT 21	39	J5		
18	SPARE	TLM DATA INPUT 22	40	J5		
19	SPARE	TLM DATA INPUT 23	41	J5		
20	TLM PASS ALG RTN	TLM REF INPUT 2	42	J5		
21	TLM PASS ALG RTN	TLM REF INPUT 3	68	J6		
22	OUTER SHELL TEMP	TLM DATA INPUT 24	60	J6		
23	STRUCTURE TEMP 1	TLM DATA INPUT 25	61	J6		
24	STRUCTURE TEMP 2	TLM DATA INPUT 26	62	J6		
27	TLM ACT ALG RTN	TLM REF INPUT 4	10	J6		
28	PEB +5V CURRENT	TLM DATA INPUT 32	11	J6		
29	PEB +10V CURRENT	TLM DATA INPUT 33	12	J6		
30	PEB -10V CURRENT	TLM DATA INPUT 34	13	J6		
31	PEB +20V CURRENT	TLM DATA INPUT 35	14	J6		
32	PEB MICRO CURRENT	TLM DATA INPUT 36	15	J6		
35	CHASSIS GND	NC				
36	TLM ACT ALG RTN	TLM REF INPUT 4	19	J6		
37	TLM ACT ALG RTN	TLM REF INPUT 5	30	J6		
38	PEA FUSE MONITOR	TLM DATA INPUT 40	31	J6		
39	PEB FUSE MONITOR	TLM DATA INPUT 41	32	J6		
40	PEA LVPS CURRENT	TLM DATA INPUT 42	33	J6		
41	PEB LVPS CURRENT	TLM DATA INPUT 43	34	J6		
45	TLM ACT ALG RTN	TLM REF INPUT 5	39	J6		
49	SIGNAL GND	SIGNAL GND	3	J5		
50	CHASSIS GND	NC				

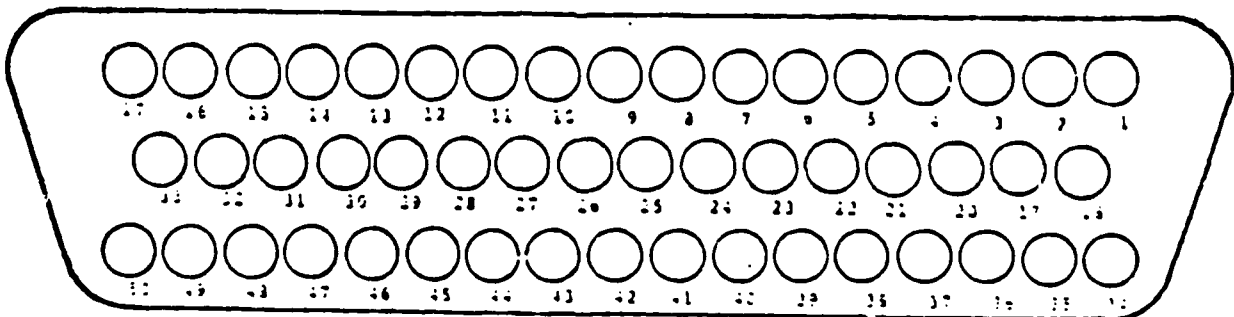

THE BOX/CHASSIS MATING/ENGAGING FACE IS SHOWN

TABLE 2-2-12. OSSE CONNECTOR PIN ASSIGNMENT (Table 3.2.7.2 of TRW-ICD, cont'd)

OSSE/GRO INSTRUMENT INTERFACE PIN CONNECTOR ASSIGNMENTS					
ICP (511)			RIO-B (621)		

CONN NO. J10 (2A014-040V-001)					
PIN NO.	OSSE FUNCTION	GRO DESCRIPTION	PIN NO.	GRO CONN.	MODULE
----	-----	-----	----	-----	-----
1	SER CMD CLK 1 TRUE	SER CMD CLK 1 TRUE	39	J7	
2	SER CMD CLK 1 COMP	SER CMD CLK 1 COMP	38	J7	
3	SER CMD CLK 2 TRUE	SER CMD CLK 2 TRUE	58	J7	
4	SER CMD CLK 2 COMP	SER CMD CLK 2 COMP	57	J7	
5	SER CMD CLK 3 TRUE	SER CMD CLK 3 TRUE	78	J7	
6	SER CMD CLK 3 COMP	SER CMD CLK 3 COMP	77	J7	
7	SER CMD CLK 4 TRUE	SER CMD CLK 4 TRUE	44	J8	
8	SER CMD CLK 4 COMP	SER CMD CLK 4 COMP	43	J8	
9	SER DATA CLK 1 TRUE	SER DATA CLK 1 TRUE	1	J5	
10	SER DATA CLK 1 COMP	SER DATA CLK 1 COMP	2	J5	
11	CHASSIS GND	NC			
12	SIGNAL GND	SIGNAL GND	3	J5	
13	MAJOR FRAME RATE SIG 3	MAJOR FRAME RATE 3	60	J7	
14	1.024 MHZ CLK 2 TRUE	1.024 MHZ CLK 2 TRUE	1	J8	
15	1.024 MHZ CLK 2 COMP	1.024 MHZ CLK 2 COMP	17	J8	
16	CONDITIONED +5.3V STBY II-3	+5.3V STBY II-3	44	J5	RIO-A(620)
17	BATSE TRIG SIG-REDUN	BTS-B, RED	22	J45	CEU-B(551)
18	SER CMD DATA 1 TRUE	SER CMD DATA 1 TRUE	37	J7	
19	SER CMD DATA 1 COMP	SER CMD DATA 1 COMP	36	J7	
20	SER CMD DATA 2 TRUE	SER CMD DATA 2 TRUE	56	J7	
21	SER CMD DATA 2 COMP	SER CMD DATA 2 COMP	55	J7	
22	SER CMD DATA 3 TRUE	SER CMD DATA 3 TRUE	76	J7	
23	SER CMD DATA 3 COMP	SER CMD DATA 3 COMP	75	J7	
24	SER CMD DATA 4 TRUE	SER CMD DATA 4 TRUE	30	J8	
25	SER CMD DATA 4 COMP	SER CMD DATA 4 COMP	29	J8	
26	SER DATA CLK 3 TRUE	SER DATA CLK 3 TRUE	3	J6	
27	SER DATA CLK 3 COMP	SER DATA CLK 3 COMP	4	J6	
28	CHASSIS GND	NC			
29	SIGNAL GND	SIGNAL GND	2	J6	
30	MAJOR FRAME RATE 4	MAJOR FRAME RATE 4	32	J8	

TABLE 2-2-13. OSSE CONNECTOR PIN ASSIGNMENT (Table 3.2.7.2 of TRW-ICD, cont'd)

OSSE/GRO INSTRUMENT INTERFACE PIN CONNECTOR ASSIGNMENTS						
ICP (511)			RIU-B (621)			

CONN NO. J10 (2A014-040V-001)						
PIN NO.	OSSE FUNCTION	GRO DESCRIPTION	PIN NO.	GRO CONN.	MODULE	
-----	-----	-----	-----	-----	-----	
31	1.024 MHZ CLK 1 TRUE	1.024 HMZ CLK 1 TRUE	3	J7		
32	1.024 MHZ CLK 1 COMP	1.024 HMZ CLK 1 COMP	2	J7		
33	CONDITIONED +5.3V STBY II-2	+5.3V STBY II-2	43	J5		
34	BATSE TRIG SIG RTN-REDUN	BTS-B RTN,RED	23	J45	CEU-B(551)	
35	SER CMD EN 0 (UTC)	SER CMD ENABLE 0 (UTC)	20	J7		
36	SER CMD EN 1	SER CMD ENABLE 1	19	J7		
37	SER CMD EN 2	SER CMD ENABLE 2	18	J7		
38	SER CMD EN 3	SER CMD ENABLE 3	17	J7		
39	SER CMD EN 4	SER CMD ENABLE 4	16	J7		
40	SER CMD EN 5	SER CMD ENABLE 5	15	J7		
41	SER CMD EN 6	SER CMD ENABLE 6	14	J8		
42	SER CMD EN 7	SER CMD ENABLE 7	13	J8		
43	SIGNAL GND	SIGNAL GND	43	J7		
44	TLM DATA I/P 0	TLM DATA INPUT 0	20	J5		
45	TLM REP I/P 0	TLM REP INPUT 0	19	J5		
46	SER/AUX TLM EN 0	SER/AUX ENABLE 0	4	J5		
47	CONDITIONED +5.3V STBY II-1	+5.3V STBY II-1	32	J5		
48	1 HZ TIMING SIG TRUE,RED	TTU 1.0 HZ,TRUE,RED	63	J105	CADH(601)	
49	1 HZ TIMING SIG COMP,RED	TTU 1.0 HZ,COMP,RED	76	J105	CADH(601)	
50	BATSE TRIG SIG SHLD,RED	BTS SHLD,RED	NC		CEU-B(551)	

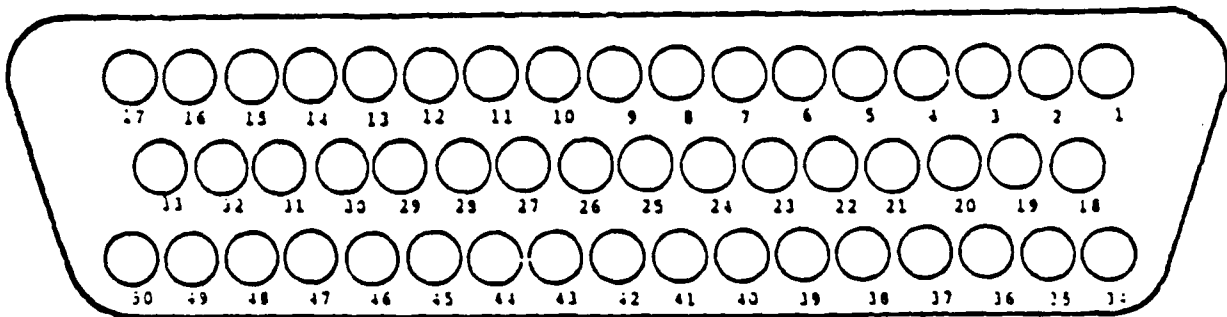

THE BOX/CHASSIS MATING/ENGAGING FACE IS SHOWN

TABLE 2-2-14. OSSE CONNECTOR PIN ASSIGNMENT (Table 3.2.7.2 of TRW-ICD, cont'd)

OSSE/GRO INSTRUMENT INTERFACE PIN CONNECTOR ASSIGNMENTS						
ICP (511)			RIU-B (621)			

CONN NO. J11 (2A014-040V-001)						

PIN NO.	OSSE FUNCTION	GRO DESCRIPTION	PIN NO.	GRO CONN.	MODULE	

1	TLM ACT ALG RTN	TLM REF INPUT 6	50	J6		
2	DET 1 ACTIVE HTR CURRENT	TLM DATA INPUT 52	55	J6		
3	DET 2 ACTIVE HTR CURRENT	TLM DATA INPUT 53	56	J6		
4	DET 3 ACTIVE HTR CURRENT	TLM DATA INPUT 54	57	J6		
5	DET 4 ACTIVE HTR CURRENT	TLM DATA INPUT 55	58	J6		
6	TLM ACT ALG RTN	TLM REF INPUT 6	59	J6		
7	TLM ACT ALG RTN	TLM REF INPUT 7	69	J6		
8	DET 1 MAKEUP MONITOR	TLM DATA INPUT 56	70	J6		
9	DET 2 MAKEUP MONITOR	TLM DATA INPUT 57	71	J6		
10	DET 3 MAKEUP MONITOR	TLM DATA INPUT 58	72	J6		
11	DET 4 MAKEUP MONITOR	TLM DATA INPUT 59	73	J6		
12	CE MAKEUP HTR MONITOR	TLM DATA INPUT 60	74	J6		
13	TLM ACT ALG RTN	TLM REF INPUT 7	78	J6		
14	TLM BILEVEL RTN	TLM REF INPUT 0	19	J5	EU (622)	
15	DET 1 ACTIVE HTR ON/OFF	TLM DATA INPUT 0	20	J5	EU (622)	
16	DET 2 ACTIVE HTR ON/OFF	TLM DATA INPUT 1	21	J5	EU (622)	
17	DET 3 ACTIVE HTR ON/OFF	TLM DATA INPUT 2	22	J5	EU (622)	
18	DET 4 ACTIVE HTR ON/OFF	TLM DATA INPUT 3	23	J5	EU (622)	
23	TLM BILEVEL RTN	TLM REF INPUT 0	28	J5	EU (622)	
31	TLM BILEVEL RTN	TLM REF INPUT 5	30	J4	EU (622)	
32	RIU-B SELECTED	TLM DATA INPUT 40	31	J4	EU (622)	
33	S/C PRIME PWR-PRIM SELECT	TLM DATA INPUT 41	32	J4	EU (622)	
35	S/C HTR PWR-PRIM SELECT	TLM DATA INPUT 43	34	J4	EU (622)	
36	S/C MAKEUP PWR-PRIM SELECT	TLM DATA INPUT 44	35	J4	EU (622)	
37	TLM BILEVEL RTN	TLM REF INPUT 5	39	J4	EU (622)	
38	TLM BILEVEL RTN	TLM REF INPUT 1	21	J4	EU (622)	
39	PEA ON/OFF	TLM DATA INPUT 8	41	J4	EU (622)	
40	PEB ON/OFF	TLM DATA INPUT 9	42	J4	EU (622)	
41	CE MAKEUP ON/OFF	TLM DATA INPUT 10	43	J4	EU (622)	
42	DET 1 MAKEUP ON/OFF	TLM DATA INPUT 11	44	J4	EU (622)	
43	DET 2 MAKEUP ON/OFF	TLM DATA INPUT 12	45	J4	EU (622)	
44	DET 3 MAKEUP ON/OFF	TLM DATA INPUT 13	46	J4	EU (622)	
45	DET 4 MAKEUP ON/OFF	TLM DATA INPUT 14	47	J4	EU (622)	
46	RIU-A SELECTED	TLM DATA INPUT 15	48	J4	EU (622)	
47	TLM BILEVEL RTN	TLM REF INPUT 1	49	J4	EU (622)	
50	CRASSIS GND	BC				

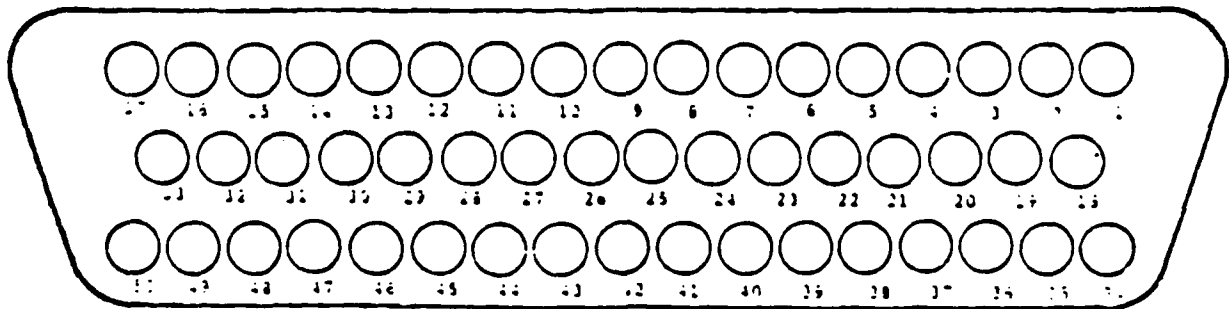

THE BOX/CHASSIS MATING/ENGAGING FACE IS SHOWN

TABLE 2-2-15. OSSE CONNECTOR PIN ASSIGNMENT (Table 3.2.7.2 of TRW-ICD, cont'd)

OSSE/GRO
INSTRUMENT INTERFACE PIN CONNECTOR ASSIGNMENTS
ICP (511) | ISU (402)

CONN NO. J12 (2A012-555V-001)

PIN NO.	OSSE FUNCTION	GRO DESCRIPTION	PIN NO.	GRO CONN.	MODULE
A	+28V QUIET, RED	INSTR PWR (RED)			
B	+28V QUIET, RED	INSTR PWR (RED)			
C	+28V QUIET RTN, RED	INSTR PWR RTN (RED)			
D	+28V QUIET RTN, RED	INSTR PWR RTN (RED)			
E	+28V THER, RED	T/C HTR PWR (RED)			
F	+28V THER, RED	T/C HTR PWR (RED)			
G	+28V THER RTN, RED	T/C HTR PWR RTN(RED)			
H	+28V THER RTN, RED	T/C HTR PWR RTN(RED)			
J	+28V MAKEUP, RED	M/U HTR PWR (RED)			
K	+28V MAKEUP, RED	M/U HTR PWR (RED)			
L	+28V MAKEUP RTN, RED	M/U HTR PWR RTN(RED)			
M	+28V MAKEUP RTN, RED	M/U HTR PWR RTN(RED)			
R	+28V QUIET, RED	INSTR PWR(RED)			
S	+28V QUIET RTN, RED	INSTR PWR RTN(RED)			
X	CHASSIS GND	NC			

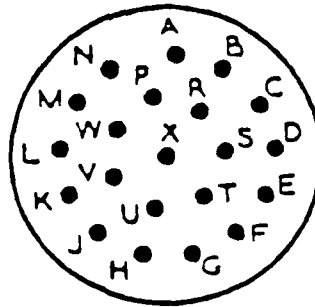

THE BOX/CHASSIS MATING/ENGAGING FACE IS SHOWN

TABLE 2-2-16. OSSE CONNECTOR PIN ASSIGNMENT (Table 3.2.7.2 of TRW-ICD, cont'd)

OSSE/GRO INSTRUMENT INTERFACE PIN CONNECTOR ASSIGNMENTS				
ICP (511)		IPJ		
CONN NO. J13 (2A014-037V-001)		(2A014-032V-001)		
PIN NO.	OSSE FUNCTION	GRO DESCRIPTION	PIN NO.	REMARKS
1	DET 1 HEATER POWER	THRMST OUTPUT FOR DET 1 STS HTR	1	CONN TO PIN 6
2	DET 2 HEATER POWER	THRMST OUTPUT FOR DET 2 STS HTR	2	CONN TO PIN 7
3	DET 3 HEATER POWER	THRMST OUTPUT FOR DET 3 STS HTR	3	CONN TO PIN 8
4	DET 4 HEATER POWER	THRMST OUTPUT FOR DET 4 STS HTR	4	CONN TO PIN 9
5	CE HEATER POWER	THRMST OUTPUT FOR CE STS HTR	5	CONN TO PIN 10
6	DET 1 HEATER	PWR INPUT TO DET 1 STS HTR	6	CONN TO PIN 1
7	DET 2 HEATER	PWR INPUT TO DET 2 STS HTR	7	CONN TO PIN 2
8	DET 3 HEATER	PWR INPUT TO DET 3 STS HTR	8	CONN TO PIN 3
9	DET 4 HEATER	PWR INPUT TO DET 4 STS HTR	9	CONN TO PIN 4
10	CE HEATER	PWR INPUT TO CE STS HTR	10	CONN TO PIN 5
11	HEATER RETURN	STS HTR PWR RTN	--	--
12	HEATER RETURN	STS HTR PWR RTN	--	--
13	HEATER RETURN	STS HTR PWR RTN	--	--
14	SPARE	NC	--	--
15	CHASSIS GND	NC	--	--

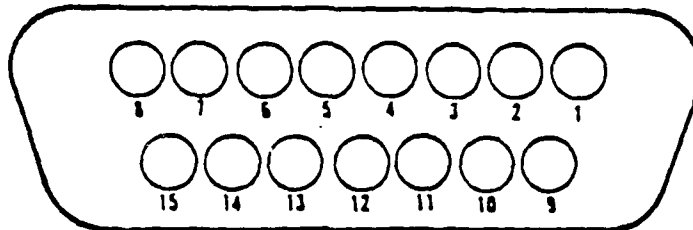

THE BOX/CHASSIS MATING/ENGAGING FACE IS SHOWN

2.2 OSSE COMMAND AND TELEMETRY LISTS

The OSSE Command and Telemetry lists are provided, using the OSSE COMMAND AND TELEMETRY DOCUMENT, No. 0926-001 Rev G (released 25-Mar-87), in Appendix 2.

2.3 OSSE PMT TUBE NUMBERING SYSTEM

The photomultiplier tube numbering system is shown on Figures 2.1 through 2.4. The following tubes have not been identified by BASD, since assembly and installation took place at Bicron Manufacturing and the information is not available at this time::

Detector A3 (150001-503): Phoswich Position: A27
A28
A29
A30
A31
A32
A33

All PMT's on Detectors A1, A2, and A4 are identified.

FIGURE 2-1. DETECTOR A1 PMT IDENTIFICATION

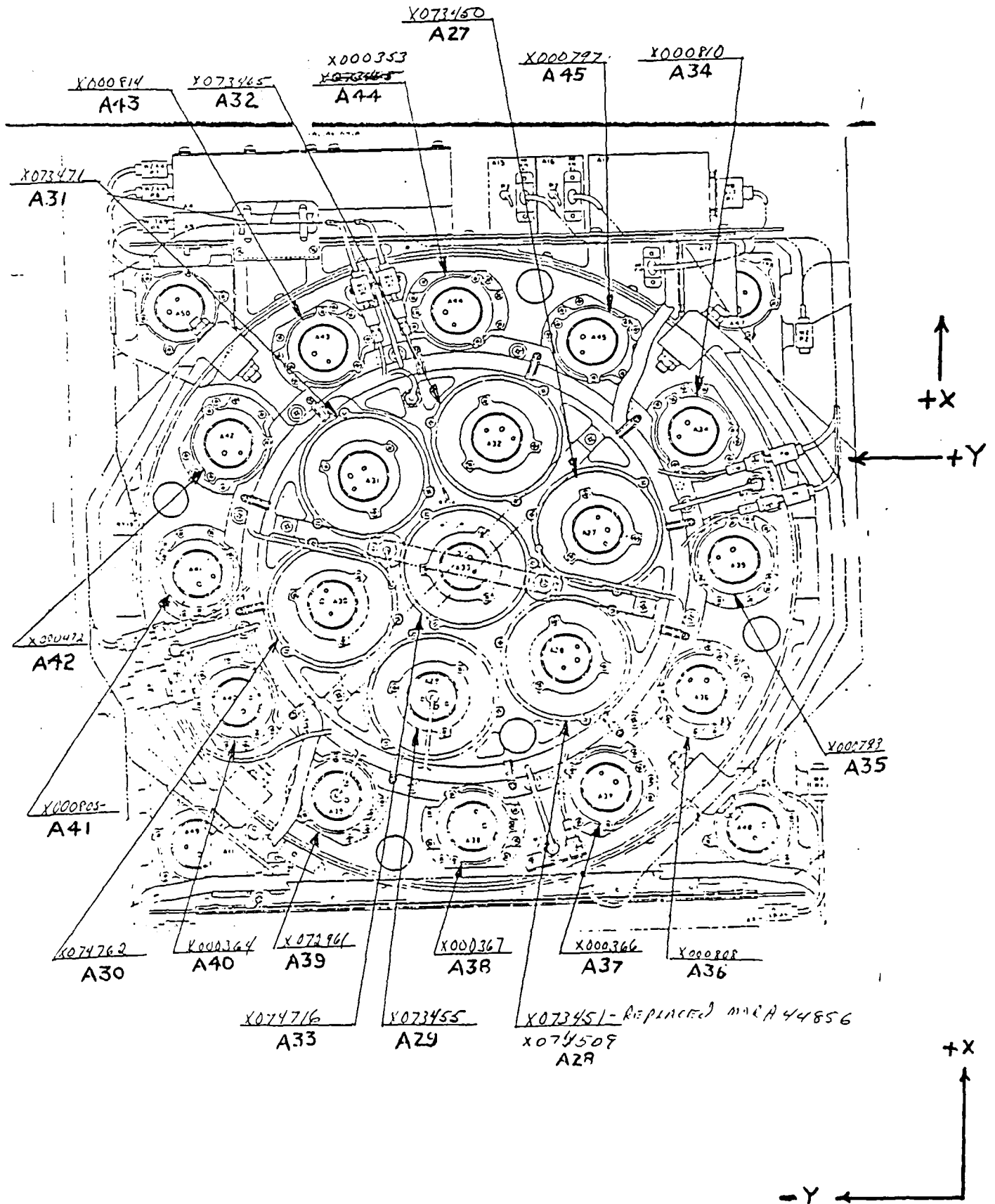

FIGURE 2-2. DETECTOR A2 PMT IDENTIFICATION

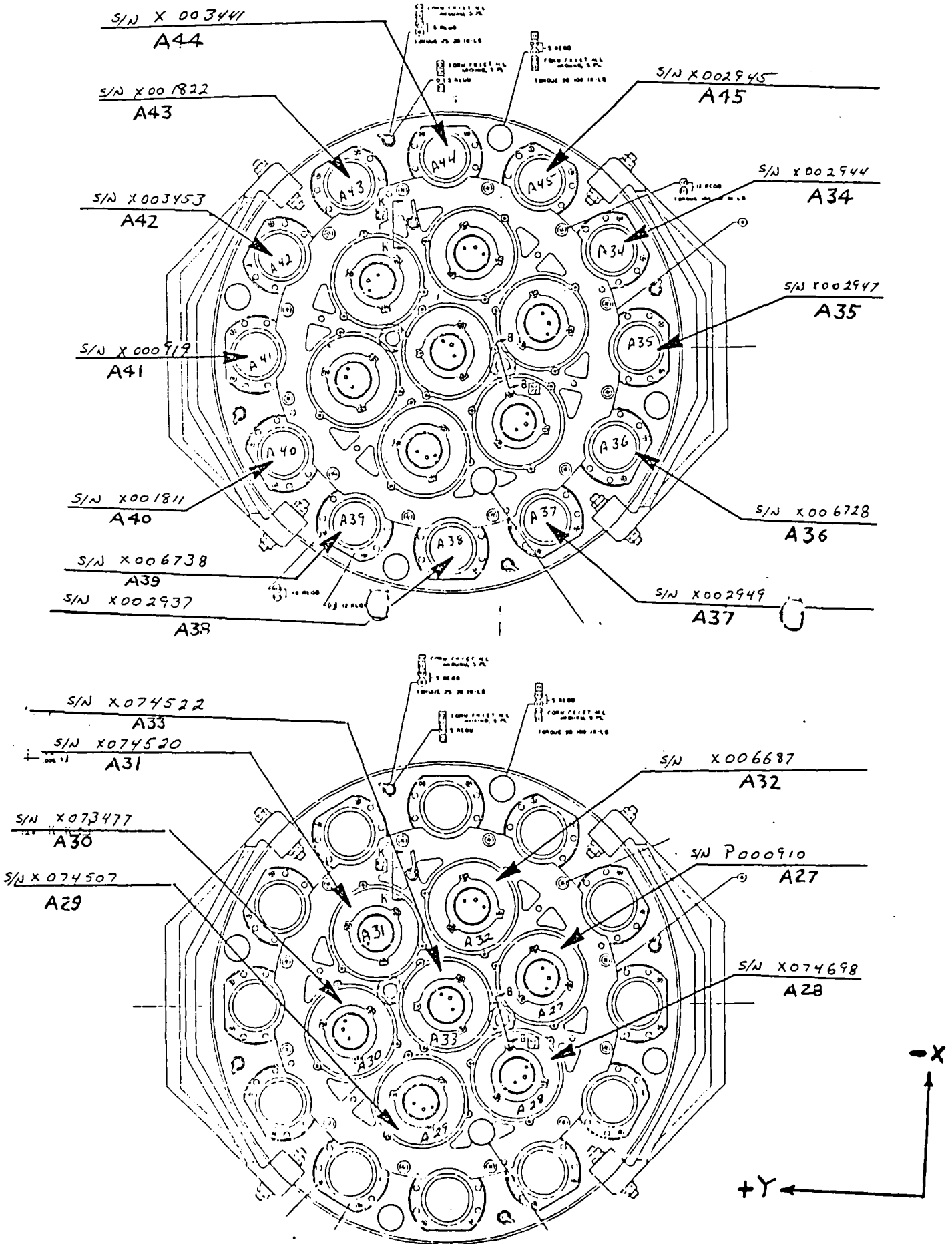

FIGURE 2-3. DETECTOR A3 PMT IDENTIFICATION

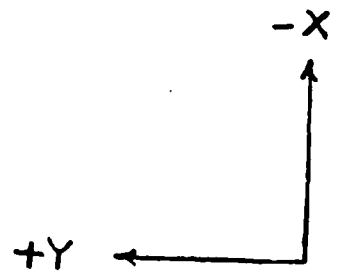
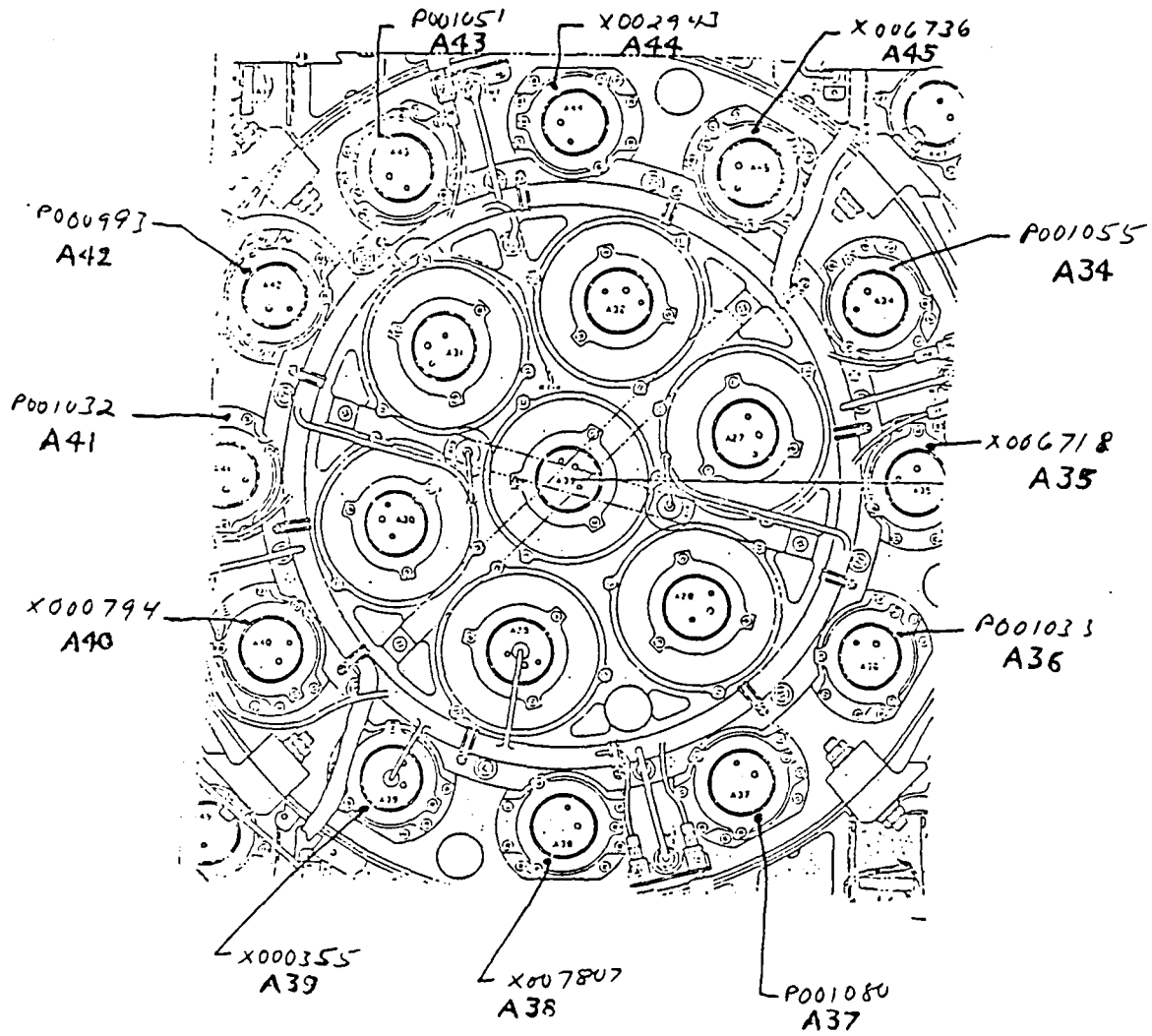
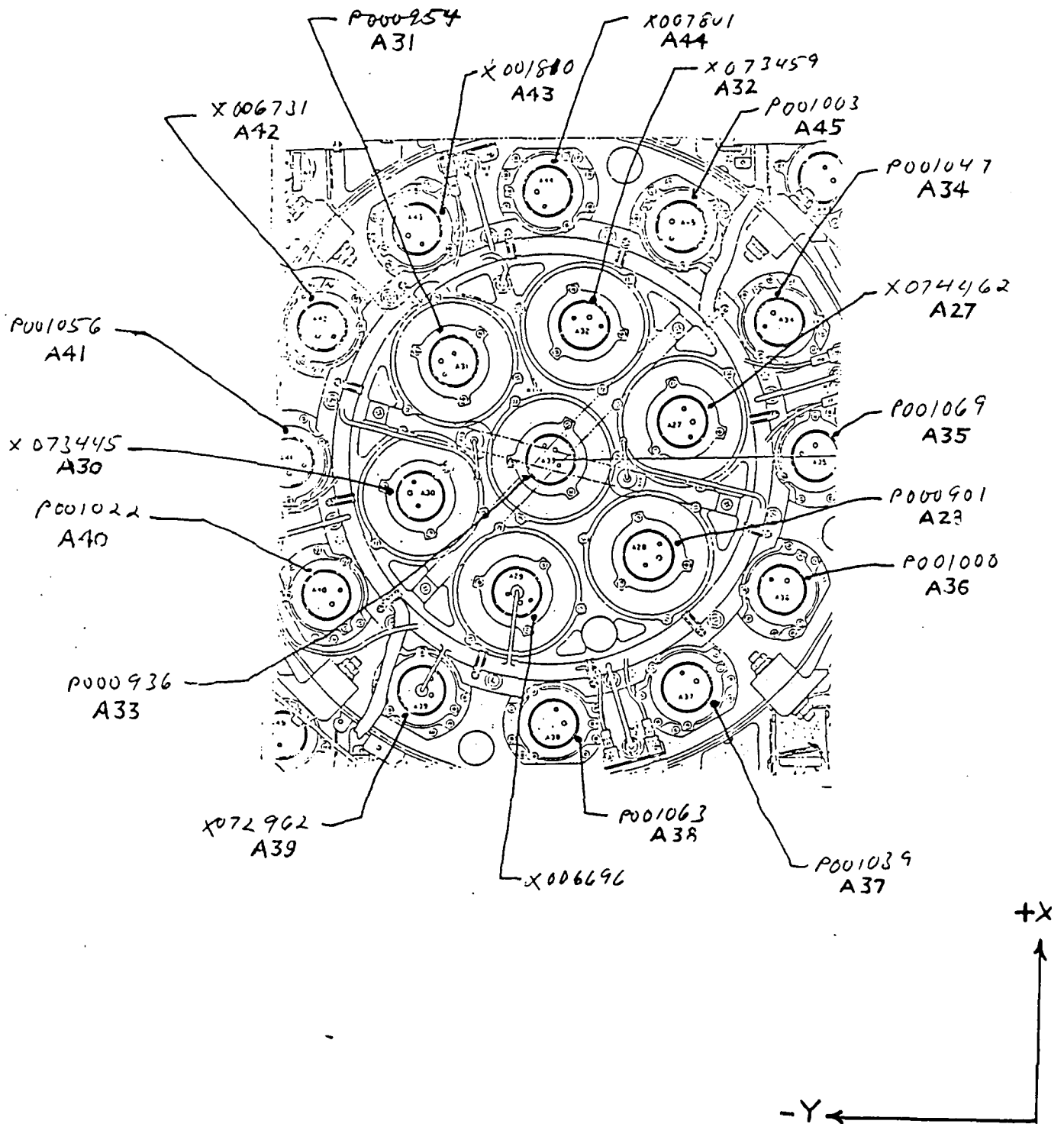

FIGURE 2-4. DETECTOR A4 PMT IDENTIFICATION



2.4 OSSE DETECTOR NUMBERING SYSTEM

The four detectors are numbered according to their position on the X-Y plane defined by the OSSE coordinate system, with X=0 and Y=0 defined as the geometric center of the instrument. The prefix 'A' is assigned to each Detector subsystem*, and the numbers 1 through 4 denote the detector by position on the structure as follows:

Detector A1 is located in the -X,-Y quadrant.
 Detector A2 is located in the -X,+Y quadrant.
 Detector A3 is located in the +X,-Y quadrant.
 Detector A4 is located in the +X,+Y quadrant.

* The prefix 'A' is also assigned to detector-mounted electronics board identification system. For example, there are boards identified as A1, A2, A3, A4, A5, through A10. However, the two entities are so different in scale that there should be no confusion as to which item is under discussion.

There was a time when detector subsystems were referred to as DE1, DE2, DE3, and DE4. This was during the building and testing phase prior to full assembly and prior to the detectors being installed on the OSSE structure. Being redesignated 'A' from 'DE' made the detectors position-specific on the OSSE structure, and the equivalency of 'DE' and 'A' is as follows:

DE2 became Detector A1 (Part No. 150010-1)
 DE1 became Detector A2 (Part No. 150010-501)
 DE4 became Detector A3 (Part No. 150010-503)
 DE3 became Detector A4 (Part No. 150001-505)

The 'DE' designator should no longer be used when referring to OSSE detectors. However, the prefix has occasionally been inadvertently used on some documentation, after top-level integration, to denote detector position on the structure (i.e., DE1=A1, DE2=A2, DE3=A3, DE4=A4). This would not be in keeping with the above-mentioned position relationship, but generally speaking, the 'DE' designator for unmounted detector subsystems was as indicated above, and applied to the pre-integration period of fabrication.

2.5 THERMISTOR CALIBRATION CURVES

Figure 2.5 is the thermistor calibration curve for the three types of thermistors used on OSSE. Of these, the 100K thermistor type accounts for the large majority, the 10K for only one (on the A3 detector board), and the 2.2K for those few that are read by the RIU only.

FIGURE 2-5. DETECTOR TEMPERATURE SENSORS (Fig 3-30 of EX056-007A)

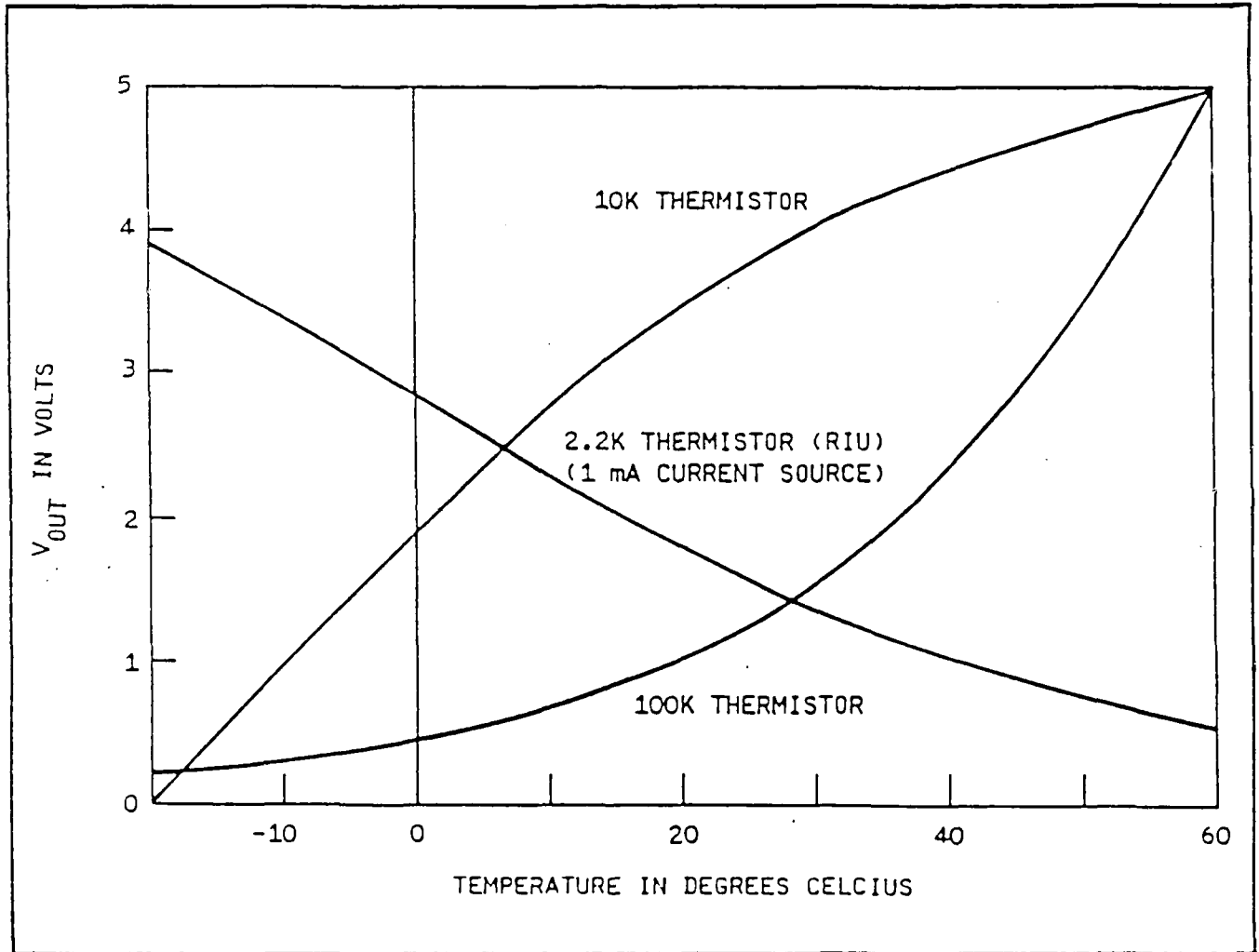

PART 3 MEASUREMENT AND TEST DATA

3.1 HOUSEKEEPING VALUES

Taken during the OSSE Instrument Calibration test period, Tables 3-1 through 3-11 show the thirty one (31) pages of OSSE status, beginning with the MENU, page 01. Reference to Appendix 2, the OSSE COMMAND AND TELEMETRY DOCUMENT No. 0926-001 Rev G (NRL) should provide an understanding of what is going on inside of OSSE.

TABLE 3-1. VIDEO MONITOR PAGES 01, 02, 03

7m27-JUL-1987 12:39:31.16 IGSE USERS = 1 FLTAUTO - Col 11 MENU Pg01
 7mTLMID:16 PKTCT: 1 PSTAT:6D80 PKTMS:1244 TMAFC:4BDD FMODE:04 SRCCT: 33353
 7mArch: TLM IDL Time: 8.222 hrs Partitions: 3 Globals: 1609 20-MAY-87

MENU	01	BILEVELS	16	PE_ANA2	31
PHOSWICH	02	PE_ANA	17	PE_ANA3	32
CO_60	03	RIU_PE	18	free	33
free	04	AGCSYS4	19	DE1_2PWR	34
AGCSYS	05	SYSPUL	20	VOPP	35
ANTICOIN	06	PHOS_1	21	FLTAUTO	36
GSH	07	PHOS_2	22	free	37
free	08	PHOS_3	23	free	38
RATES	09	PHOS_4	24	free	39
PE_STAT	10	DRIVECAL	25	free	40
POSITION	11	free	26	free	41
MD_CAL	12	free	27	CO60	42
PCU_BLVL	13	free	28	SHIELDS	43
SLCT	14	free	29	free	44
RIU_DE	15	PE_ANA1	30	free	45

7m27-JUL-1987 12:54:20.54 IGSE USERS = 1 FLTAUTO - Col 11 PHOSWICH Pg02
 7mTLMID:16 PKTCT: 3 PSTAT:7F80 PKTMS:0D04 TMAFC:4D8F FMODE:04 RCCT: 33787
 7mArch: TLM IDL Time: 7.958 hrs Partitions: 3 Globals: 1609 20-MAY-87

*HVP1\$A1	0.5 v	*HVP6\$A1	0.0 v	PINON\$B1	off
*HVP2\$A1	0.5 v	*HVP7\$A1	0.5 v	PIN\$A1	5227.8 mv
*HVP3\$A1	0.0 v			AGCRA\$B1	1000
*HVP4\$A1	0.0 v	LEDON\$B1	off	AGCPS\$B1	normal
*HVP5\$A1	0.5 v	LED\$A1	3460.7 mv		
				PHGL\$B1	high
ELDL\$A1	78.1 mv	ELDM\$A1	80.6 mv	ELDH\$A1	80.6 mv
TLDL\$A1	96.5 mv	TLDM\$A1	100.1 mv	TLDH\$A1	98.9 mv
TUDL\$A1	4912.1 mv	TUDM\$A1	4902.3 mv	TUDH\$A1	4912.1 mv
ELDL\$R1	1006.23 cs	ELDM\$R1	960.08 cs	ELDH\$R1	0.00 cs
EUDL\$R1	79.47 cs	EUDM\$R1	0.00 cs	EUDH\$R1	0.00 cs
ATWL\$R1	936.52 cs	ATWM\$R1	960.21 cs	ATWH\$R1	0.00 cs
TUDL\$R1	0.00 cs	TUDM\$R1	0.00 cs	TUDH\$R1	0.00 cs
MLL\$R1	914.43 cs	MLM\$R1	960.21 cs	MLH\$R1	0.00 cs
DTL\$R1	1.79 %	DTM\$R1	1.25 %	DTH\$R1	0.00 %

7m27-JUL-1987 12:55:10.97 IGSE USERS = 1 FLTAUTO - Col 11 CO 60 Pg03
 7mTLMID:16 PKTCT: 3 PSTAT:7F80 PKTMS:11C4 TMAFC:4DA7 FMODE:04 SRCCT: 33811
 7mArch: TLM IDL Time: 7.944 hrs Partitions: 3 Globals: 1609 20-MAY-87

CLAD\$B1	low	C6AQ\$B1	on		
CLLD\$A1	59.8 mv	C6LD\$A1	89.0 mv		
		C6LD\$R1	0. cs		
CLONE\$B1	on	VC6\$B1	on		
CLOVE\$B1	on	HVS3\$B1	off		
		*HVS3\$A1	0.0 v		

TABLE 3-2. VIDEO MONITOR PAGES 05, 06, 07

7m27-JUL-1987 12:56:18.97 IGSE USERS = 1 FLTAUTO - Col 11 AGCSYS Pg05
 7mTLMID:16 PKTCT: 1 PSTAT:7F80 PKTMS:0644 TMAFC:4DC9 FMODE:04 SRCCT: 33845
 7mArch: TLM IDL Time: 7.925 hrs Partitions: 3 Globals: 1609 20-MAY-87

*HVP1\$A1	0.5 v	AGCP1\$B1	off	AGCT2\$S	79026C Hex
*HVP2\$A1	0.5 v	AGCP2\$B1	off	AGCT3\$S	7A02DD Hex
*HVP3\$A1	0.5 v	AGCP3\$B1	off	AGCT4\$S	7B0290 Hex
*HVP4\$A1	0.0 v	AGCP4\$B1	off	AGCT5\$S	7C024B Hex
*HVP5\$A1	0.5 v	AGCP5\$B1	off	AGCT6\$S	7D02EF Hex
*HVP6\$A1	0.0 v	AGCP6\$B1	off	AGCT7\$S	7E01EC Hex
*HVP7\$A1	0.0 v	AGCP7\$B1	off	ANATA\$S	2900 Hex
LEDON\$B1	off	PINON\$B1	off		
LED\$A1	3460.7 mv	PIN\$A1	5227.8 mv		
VRPH\$B2	anti	AGCRA\$B1	1000	CLAD\$B1	low
		AGCON\$B1	off		
		AGCPS\$B1	normal		

7m27-JUL-1987 12:56:57.47 IGSE USERS = 1 FLTAUTO - Col 11 ANTICOIN Pg06
 7mTLMID:16 PKTCT: 3 PSTAT:7F80 PKTMS:0204 TMAFC:4DDB FMODE:04 SRCCT: 33863
 7mArch: TLM IDL Time: 7.913 hrs Partitions: 3 Globals: 1609 20-MAY-87

S1LD\$A1	59.8 mv	S1LD\$R1	0.00 cs	VS1LD\$B2	off
S2LD\$A1	59.2 mv	S2LD\$R1	0.00 cs	VS2LD\$B2	off
S3LD\$A1	59.8 mv	S3LD\$R1	0.00 cs	VS3LD\$B2	off
S4LD\$A1	59.8 mv	S4LD\$R1	0.00 cs	VS4LD\$B2	off
CPD\$A1	79.4 mv	CPD\$R1	0.00 cs	VCPD\$B1	on
C6LD\$A1	89.0 mv	C6LD\$R1	0. cs	VC6\$B1	on
		SMD\$R1	0.00 cs	VSMDB2	off
		SUD\$R1	0.00 cs	VSUD\$B2	off
				VOPP\$B2	off
HVS1\$B1	off	*HVS1\$A1	0.0 v		
HVS2\$B1	off	*HVS2\$A1	0.5 v		
HVS3\$B1	off	*HVS3\$A1	0.0 v		
				CLAD\$B1	low
				CLLR\$B1	remote
				CLLD\$A1	61.0 mv

7m27-JUL-1987 13:12:22.97 IGSE USERS = 1 FLTAUTO - Col 11 GSH Pg07
 7mTLMID:16 PKTCT: 3 PSTAT:7F80 PKTMS:17C4 TMAFC:4F9F FMODE:04 SRCCT: 34315
 7mArch: TLM IDL Time: 7.644 hrs Partitions: 3 Globals: 1609 20-MAY-87

SRCID\$P	103	UTC\$P	*****
MISID\$P	136	POSX\$P	0
SRCCT\$P	34315	POSY\$P	0
PKTLT\$P	255	POSZ\$P	0
		GEOAZ\$P	0
SCHDR\$P	255	GEOEL\$P	0
SRCP\$P	46599	ATTZR\$P	0
		ATTZD\$P	0
		ATTXR\$P	0
		ATTXD\$P	0

TABLE 3-3. VIDEO MONITOR PAGES 09, 10, 11

7m27-JUL-1987 13:13:14.22 IGSE USERS = 1 FLTAUTO - Col 11 RATES Pg 09
 7mTLMID:16 PKTCT: 4 PSTAT:7F80 PKTMS:1E04 TMAFC:4FB8 FMODE:04 SRCCT: 34340
 7mArch: TLM IDL Time: 7.630 hrs Partitions: 3 Globals: 1609 20-MAY-87

FDET1\$P	0080 Hex	FDET2\$P	0080 Hex	PSTAT\$P	7F80 Hex
FDET3\$P	0080 Hex	FDET4\$P	0080 Hex	CPMEL\$R	0000 Hex
CAUTH\$P	138	BAUTH\$P	10	CPMPR\$R	0000 Hex
ELDL\$R1	998.05 cs	ELDM\$R1	906.86 cs	ELDH\$R1	0.00 cs
MLL\$R1	950.44 cs	MLM\$R1	906.86 cs	MLH\$R1	0.00 cs
DTL\$R1	1.62 Z	DTM\$R1	1.17 Z	DTH\$R1	0.00 Z
ELDL\$R2	1000.12 cs	ELDM\$R2	904.05 cs	ELDH\$R2	0.00 cs
MLL\$R2	961.67 cs	MLM\$R2	904.05 cs	MLH\$R2	0.00 cs
DTL\$R2	1.61 Z	DTM\$R2	1.17 Z	DTH\$R2	0.00 Z
ELDL\$R3	989.14 cs	ELDM\$R3	895.02 cs	ELDH\$R3	0.00 cs
MLL\$R3	950.56 cs	MLM\$R3	895.02 cs	MLH\$R3	0.00 cs
DTL\$R3	1.61 Z	DTM\$R3	1.18 Z	DTH\$R3	0.00 Z
ELDL\$R4	985.35 cs	ELDM\$R4	895.14 cs	ELDH\$R4	0.00 cs
MLL\$R4	935.67 cs	MLM\$R4	895.14 cs	MLH\$R4	0.00 cs
DTL\$R4	1.63 Z	DTM\$R4	1.17 Z	DTH\$R4	0.00 Z

7m27-JUL-1987 13:13:48.73 IGSE USERS = 1 FLTAUTO - Col 11 PE STAT Pg 10
 7mTLMID:16 PKTCT: 1 PSTAT:7F80 PKTMS:1E44 TMAFC:4FC9 FMODE:04 SRCCT: 34357
 7mArch: TLM IDL Time: 7.620 hrs Partitions: 3 Globals: 1609 20-MAY-87

FMODE\$P	0004 Hex	CAUTH\$P	138	PSTAT\$P	7F80 Hex
FSTAT\$P	0000 Hex	CMREJ\$P	0		
FERR\$P	0000 Hex	BAUTH\$P	10	CALIB\$B	on
		BCREJ\$P	0	BURST\$B	on
FDET1\$P	0080 Hex	MEMER\$P	0	RPHA2\$B	on
FDET2\$P	0080 Hex			RPHA1\$B	on
FDET3\$P	0080 Hex	CPMEL\$R	0000 Hex	MDCAL\$B	on
FDET4\$P	0080 Hex	CPMPR\$R	0000 Hex	MDPOSS\$B	on
DPTBL\$P	prim	CPSAA\$B	no	AGC\$B	on
DPMOD\$B	norm	HVCPM\$B	on	CO60\$B	on
DPDLY\$B	no	HVCPM\$A	799.8 v	PULSR\$B	off
		*CPMR\$A	-64.9 mv		
BURAC\$B	no	CPMTH\$P	0100 Hex	PULSM\$P	inactive
SBURS\$B	no	CPMCT\$P	4	PULST\$P	0000 Hex
CKR\$P	44849				

7m27-JUL-1987 13:14:28.24 IGSE USERS = 1 FLTAUTO - Col 11 POSITION Pg 11
 7mTLMID:16 PKTCT: 4 PSTAT:7F80 PKTMS:1584 TMAFC:4FDC FMODE:04 SRCCT: 34376
 7mArch: TLM IDL Time: 7.608 hrs Partitions: 3 Globals: 1609 20-MAY-87

DPTBL\$P	prim	MODE\$P	science	SPRI\$B	on
DPMOD\$B	norm	PSTAT\$P	7F80 Hex	SSEC\$B	off
DPDLY\$B	no	MDCAL\$B	on	SSUN\$B	off
		MDPCS\$B	on	STRAN\$B	off
FDET1\$P	0080 Hex				
FDET2\$P	0080 Hex	CAUTH\$P	138	CMREJ\$P	0
FDET3\$P	0080 Hex	BAUTH\$P	10	BCREJ\$P	0
FDET4\$P	0080 Hex	DEMGS\$P	9999 Hex		
D1SA\$P	1627	A1M\$A	6849.7 mv	A1R\$A	6849.7 mv
D2SA\$P	1627	A2M\$A	6743.8 mv	A2R\$A	6747.2 mv
D3SA\$P	1612	A3M\$A	6863.4 mv	A3R\$A	6863.4 mv
D4SA\$P	1612	A4M\$A	6801.9 mv	A4R\$A	6795.0 mv

TABLE 3-4. VIDEO MONITOR PAGES 12, 13, 14

7m27-JUL-1987 13:14:54.11 IGSE USERS = 1 FLTAUTO - Col 11 MD CAL Pg 12

7mTLMID:16 PKTCT: 1 PSTAT:7F80 PKTMS:09C4 TMAFC:4FE9 FMODE:04 SRCCT: 34389

7mArch: TLM IDL Time: 7.601 hrs Partitions: 3 Globals: 1609 20-MAY-87

FMODE\$P	0004 Hex	FDET1\$P	0080 Hex	FDET2\$P	0080 Hex
PSTAT\$P	7F80 Hex	FDET3\$P	0080 Hex	FDET4\$P	0080 Hex
DEMGS\$P	9999 Hex	CAUTH\$P	138	BAUTH\$P	10
MDCRF1\$A	-7000.0 mv	ASE1\$P	0	MDCJS1\$P	0000 Hex
MDCRF2\$A	-7000.0 mv	ASE2\$P	0	MDCJS2\$P	0000 Hex
MDCRF3\$A	-7000.0 mv	ASE3\$P	0	MDCJS3\$P	0000 Hex
MDCRF4\$A	-7000.0 mv	ASE4\$P	0	MDCJS4\$P	0000 Hex
MDCST1\$P	0000 Hex	ALM\$A	6849.7 mv	IP1M\$A	6849.7 mv
MDCST2\$P	0000 Hex	A2M\$A	6743.8 mv	IP2M\$A	6743.8 mv
MDCST3\$P	0000 Hex	A3M\$A	6863.4 mv	IP3M\$A	6863.4 mv
MDCST4\$P	0000 Hex	A4M\$A	6801.9 mv	IP4M\$A	6801.9 mv
D1SA\$P	1627	A1R\$A	6849.7 mv	IP1R\$A	6849.7 mv
D2SA\$P	1627	A2R\$A	6747.2 mv	IP2R\$A	6747.2 mv
D3SA\$P	1612	A3R\$A	6863.4 mv	IP3R\$A	6863.4 mv
D4SA\$P	1612	A4R\$A	6795.0 mv	IP4R\$A	6795.0 mv

7m27-JUL-1987 13:15:25.44 IGSE USERS = 1 FLTAUTO - Col 11 PCU BLVL Pg 13

7mTLMID:16 PKTCT: 4 PSTAT:7F80 PKTMS:0104 TMAFC:4FF8 FMODE:04 SRCCT: 34404

7mArch: TLM IDL Time: 7.591 hrs Partitions: 3 Globals: 1609 20-MAY-87

PCBI1\$P	7DF9 Hex	MREGA\$B	on	PWRD1\$B	on
PCBI2\$P	53FF Hex	MREGB\$B	off	PWRD2\$B	on
PCDET\$P	FFFF Hex	AHTR1\$B	off	PWRD3\$B	on
PCHTR\$P	AABF Hex	AHTR2\$B	off	PWRD4\$B	on
		AHTR3\$B	off		
		AHTR4\$B	off	TPWR1\$B	a
		SRIUA\$B	on	TPWR2\$B	b
		SRIUB\$B	off	TPWR3\$B	b
		MTRA1\$B	a	TPWR4\$B	a
		MTRA2\$B	a		
		MTRA3\$B	a		
		MTRA4\$B	a		

7m27-JUL-1987 13:15:45.08 IGSE USERS = 1 FLTAUTO - Col 11 SLOT Pg 14

7mTLMID:16 PKTCT: 2 PSTAT:7F80 PKTMS:1004 TMAFC:5002 FMODE:04 SRCCT: 34414

7mArch: TLM IDL Time: 7.584 hrs Partitions: 3 Globals: 1609 20-MAY-87

SOPID\$P	0088 Hex	S1PID\$P	0003 Hex	S2PID\$P	0006 Hex
SOSEQ\$P	0010 Hex	S1SEQ\$P	0035 Hex	S2SEQ\$P	0005 Hex
SOTEN\$P	0000 Hex	S1TEN\$P	0000 Hex	S2TEN\$P	0003 Hex
SOMFC\$P	4FDD Hex	S1MFC\$P	4FA1 Hex	S2MFC\$P	4FD9 Hex
SORAC\$P	00B9 Hex	S1RAC\$P	0007 Hex	S2RAC\$P	0010 Hex

RPHA1\$B	on		
RPHA2\$B	on	BAUTH\$P	10
CO60\$B	on	ERLOG\$P	1
CALIB\$B	on		
BURST\$B	on		

TABLE 3-5. VIDEO MONITOR PAGES 15, 16, 17

7m27-JUL-1987 13:16:06.19 IGSE USERS = 1 FLTAUTO - Col 11 RIU DE Pg 15

7mTLMID:16 PKTCT: 4 PSTAT:7F80 PKTMS:1F04 TMAFC:500C FMODE:04 SRCCT: 34424

7mArch: TLM IDL Time: 7.580 hrs Partitions: 3 Globals: 1609 20-MAY-87

RPRIP\$B	main	RHTRP\$B	main	RMAKP\$B	main
RAHT1\$B	on	RAHT1\$A	0.000 a	RSTS1\$A	0.000 v
RAHT2\$B	on	RAHT2\$A	0.000 a	RSTS2\$A	0.000 v
RAHT3\$B	on	RAHT3\$A	0.000 a	RSTS3\$A	0.000 v
RAHT4\$B	on	RAHT4\$A	0.000 a	RSTS4\$A	0.000 v
				RSTSP\$A	0.000 v
RMHT1\$B	on	RMHT1\$A	0.000 v	R1TMP\$A	0.00 c
RMHT2\$B	on	RMHT2\$A	0.000 v	R2TMP\$A	0.00 c
RMHT3\$B	on	RMHT3\$A	0.000 v	R3TMP\$A	0.00 c
RMHT4\$B	on	RMHT4\$A	0.000 v	R4TMP\$A	0.00 c
RMHT5\$B	on	RMHT5\$A	0.000 v	ROSTM\$A	0.00 c
				RSTM1\$A	0.00 c
				RSTM2\$A	0.00 c

7m27-JUL-1987 13:17:09.62 IGSE USERS = 1 FLTAUTO - Col 11 BILEVELS Pg 16

7mTLMID:16 PKTCT: 3 PSTAT:7F80 PKTMS:0F04 TMAFC:502B FMODE:04 SRCCT: 34455

7mArch: TLM IDL Time: 7.560 hrs Partitions: 3 Globals: 1609 20-MAY-87

SPRIP\$B	main	SHTRP\$B	redn	SMAKP\$B	main
TPWR1\$B	a	MTRA1\$B	a	AHTR1\$B	off
TPWR2\$B	b	MTRA2\$B	a	AHTR2\$B	off
TPWR3\$B	b	MTRA3\$B	a	AHTR3\$B	off
TPWR4\$B	a	MTRA4\$B	a	AHTR4\$B	off
MREGA\$B	on	SRIUA\$B	on		
MREGB\$B	off	SRIUB\$B	off		
MTRLL\$B	off				

7m27-JUL-1987 13:17:29.07 IGSE USERS = 1 FLTAUTO - Col 11 PE ANA Pg 17

7mTLMID:16 PKTCT: 1 PSTAT:7F80 PKTMS:1E04 TMAFC:5035 FMODE:04 SRCCT: 34465

7mArch: TLM IDL Time: 7.556 hrs Partitions: 3 Globals: 1609 20-MAY-87

PE5V\$A	4.969 v	MTRAC\$A	0.017 a
PE10V\$A	10.605 v	MTRBC\$A	0.010 a
PE20V\$A	21.273 v	*MTD1C\$A	-0.001 a
PE5C\$A	2.876 a	*MTD2C\$A	-0.001 a
PE10C\$A	78.2 ma	*MTD3C\$A	-0.001 a
PE20C\$A	6.0 ma	*MTD4C\$A	-0.001 a
PN10V\$A	-10.595 v	MTRAT\$A	17.88 c
PN10C\$A	68.6 ma	MTRBT\$A	16.21 c
PL10V\$A	10.457 v		
PL5V\$A	4.905 v		
PLN10\$A	-10.413 v		
PEPTM\$A	18.50 c		
HVCPM\$A	799.8 v		
QBV\$A	27.608 v		
*TBV\$A	-0.020 v		

TABLE 3-6. VIDEO MONITOR PAGES 18, 19, 20

7m27-JUL-1987 13:17:50.74 IGSE USERS = 1 FLTAUTO - Col 11 RIU PE Pg 18
 7mTLMID:16 PKTCT: 3 PSTAT:7F80 PKTMS:0DC4 TMAFC:503F FMODE:04 SRCCT: 34475
 7mArch: TLM IDL Time: 7.549 hrs Partitions: 3 Globals: 1609 20-MAY-87

RPEASB	on	RPEBSB	on	RRIUA\$B	on
				RRIUB\$B	on
RA5C\$A	0.000 a	RB5C\$A	0.000 a	RPRIP\$B	main
RA10C\$A	0.0 ma	RB10C\$A	0.0 ma	RMAKP\$B	main
RAN10\$A	0.0 ma	RBN10\$A	0.0 ma		
RA20C\$A	0.0 ma	RB20C\$A	0.0 ma		
RAMIC\$A	0.0 ma	RBMIC\$A	0.0 ma		
RFMNA\$A	0.000 v	RFMNB\$A	0.000 v		
RLVCA\$A	0.000 a	RLVCB\$A	0.000 a		

7m27-JUL-1987 13:18:09.69 IGSE USERS = 1 FLTAUTO - Col 11 AGCSYS4 Pg 19
 7mTLMID:16 PKTCT: 4 PSTAT:7F80 PKTMS:1B44 TMAFC:5048 FMODE:04 SRCCT: 34485
 7mArch: TLM IDL Time: 7.544 hrs Partitions: 3 Globals: 1609 20-MAY-87

*HVP1\$A4	0.0 v	AGCP1\$B4	off	AGCT2\$S	79026C Hex
*HVP2\$A4	0.0 v	AGCP2\$B4	off	AGCT3\$S	7A02DD Hex
*HVP3\$A4	0.0 v	AGCP3\$B4	off	AGCT4\$S	7B0290 Hex
*HVP4\$A4	0.0 v	AGCP4\$B4	off	AGCT5\$S	7C024B Hex
*HVP5\$A4	0.0 v	AGCP5\$B4	off	AGCT6\$S	7D02EF Hex
*HVP6\$A4	0.0 v	AGCP6\$B4	off	AGCT7\$S	7E01EC Hex
*HVP7\$A4	0.0 v	AGCP7\$B4	off	ANATA\$S	2900 Hex
LEDON\$B4	off	PINON\$B4	off		
LED\$A4	3469.3 mv	PIN\$A4	5244.9 mv		
VS1LD\$B1	off	AGCRA\$B4	1000	CLAD\$B4	low
		AGCON\$B4	off		
		AGCPS\$B4	normal		

7m27-JUL-1987 13:16:39.91 IGSE USERS = 1 FLTAUTO - Col 11 SYSPUL Pg 20
 7mTLMID:16 PKTCT: 1 PSTAT:7F80 PKTMS:1944 TMAFC:501D FMODE:04 SRCCT: 34441
 7mArch: TLM IDL Time: 7.570 hrs Partitions: 3 Globals: 1609 20-MAY-87

MLL\$R1	910.03 cs	MLM\$R1	907.59 cs	MLH\$R1	0.00 cs
MLL\$R2	958.37 cs	MLM\$R2	903.69 cs	MLH\$R2	0.00 cs
MLL\$R3	949.95 cs	MLM\$R3	895.02 cs	MLH\$R3	0.00 cs
MLL\$R4	927.98 cs	MLM\$R4	895.51 cs	MLH\$R4	0.00 cs
BAUTH\$P	10	D1POS\$P	0	LVL1\$P1	CFC0 Hex
PULSM\$P	inactive	D2POS\$P	0	LVL1\$P2	EFC7 Hex
PULWD\$P	0000 Hex	D3POS\$P	0	LVL1\$P3	EFC7 Hex
PULEB\$B	0000 Hex	D4POS\$P	0	LVL1\$P4	EFC7 Hex
PULRC\$P	0000 Hex				
PULRT\$P	0000 Hex				

TABLE 3-7. VIDEO MONITOR PAGES 21, 22, 23

7m27-JUL-1987 13:18:30.59 IGSE USERS = 1 FLTAUTO - Col 11 PHOS 1 Pg 21
 7mTLMID:16 PKTCT: 3 PSTAT:7F80 PKTMS:0C84 TMAFC:5053 FMODE:04 SRCCT: 34495
 7mArch: TLM IDL Time: 7.537 hrs Partitions: 3 Globals: 1609 20-MAY-87

*HVP1\$A1	0.5 v	*HVP6\$A1	0.5 v	PINON\$B1	off
*HVP2\$A1	0.5 v	*HVP7\$A1	0.5 v	PIN\$A1	5227.8 mv
*HVP3\$A1	0.5 v			AGCRA\$B1	1000
*HVP4\$A1	0.5 v	LEDON\$B1	off	AGCPS\$B1	normal
*HVP5\$A1	0.5 v	LED\$A1	3460.7 mv		
				PHGL\$B1	high
ELDL\$A1	80.6 mv	ELDM\$A1	79.4 mv	ELDH\$A1	79.4 mv
TLDL\$A1	100.1 mv	TLDM\$A1	100.1 mv	TLDH\$A1	98.9 mv
TUDL\$A1	4914.5 mv	TUDM\$A1	4901.1 mv	TUDH\$A1	4912.1 mv
ELDL\$R1	998.78 cs	ELDM\$R1	906.49 cs	ELDH\$R1	0.00 cs
EUDL\$R1	39.92 cs	EUDM\$R1	0.00 cs	EUDH\$R1	0.00 cs
ATWL\$R1	960.45 cs	ATWM\$R1	906.49 cs	ATWH\$R1	0.00 cs
TUDL\$R1	0.00 cs	TUDM\$R1	0.00 cs	TUDH\$R1	0.00 cs
MLL\$R1	950.68 cs	MLM\$R1	906.49 cs	MLH\$R1	0.00 cs
DTL\$R1	1.63 %	DTM\$R1	1.17 %	DTH\$R1	0.00 %

7m27-JUL-1987 13:20:17.11 IGSE USERS = 1 FLTAUTO - Col 11 PHOS 2 Pg 22
 7mTLMID:16 PKTCT: 3 PSTAT:7F80 PKTMS:1C04 TMAFC:5087 FMODE:04 SRCCT: 34547
 7mArch: TLM IDL Time: 7.506 hrs Partitions: 3 Globals: 1609 20-MAY-87

*HVP1\$A2	0.0 v	*HVP6\$A2	0.0 v	PINON\$B2	off
*HVP2\$A2	0.0 v	*HVP7\$A2	0.0 v	PIN\$A2	5234.7 mv
*HVP3\$A2	0.0 v			AGCRA\$B2	1000
*HVP4\$A2	0.0 v	LEDON\$B2	off	AGCPS\$B2	normal
*HVP5\$A2	0.0 v	LED\$A2	3462.4 mv		
				PHGL\$B2	high
ELDL\$A2	78.1 mv	ELDM\$A2	79.4 mv	ELDH\$A2	81.8 mv
TLDL\$A2	97.7 mv	TLDM\$A2	97.7 mv	TLDH\$A2	97.7 mv
TUDL\$A2	4898.7 mv	TUDM\$A2	4901.1 mv	TUDH\$A2	4903.5 mv
ELDL\$R2	1007.20 cs	ELDM\$R2	959.11 cs	ELDH\$R2	0.00 cs
EUDL\$R2	73.12 cs	EUDM\$R2	0.00 cs	EUDH\$R2	0.00 cs
ATWL\$R2	942.75 cs	ATWM\$R2	959.11 cs	ATWH\$R2	0.00 cs
TUDL\$R2	0.00 cs	TUDM\$R2	0.00 cs	TUDH\$R2	0.00 cs
MLL\$R2	933.47 cs	MLM\$R2	959.11 cs	MLH\$R2	0.00 cs
DTL\$R2	1.78 %	DTM\$R2	1.24 %	DTH\$R2	0.00 %

7m27-JUL-1987 13:20:33.01 IGSE USERS = 1 FLTAUTO - Col 11 PHOS 3 Pg 23
 7mTLMID:16 PKTCT: 2 PSTAT:7F80 PKTMS:0744 TMAFC:508E FMODE:04 SRCCT: 34554
 7mArch: TLM IDL Time: 7.501 hrs Partitions: 3 Globals: 1609 20-MAY-87

*HVP1\$A3	0.5 v	*HVP6\$A3	0.0 v	PINON\$B3	off
*HVP2\$A3	0.5 v	*HVP7\$A3	0.5 v	PIN\$A3	5233.0 mv
*HVP3\$A3	0.0 v			AGCRA\$B3	1000
*HVP4\$A3	0.0 v	LEDON\$B3	off	AGCPS\$B3	normal
*HVP5\$A3	0.0 v	LED\$A3	3460.7 mv		
				PHGL\$B3	high
ELDL\$A3	78.1 mv	ELDM\$A3	80.6 mv	ELDH\$A3	79.4 mv
TLDL\$A3	98.9 mv	TLDM\$A3	100.1 mv	TLDH\$A3	98.9 mv
TUDL\$A3	4906.0 mv	TUDM\$A3	4904.8 mv	TUDH\$A3	4903.5 mv
ELDL\$R3	989.14 cs	ELDM\$R3	896.24 cs	ELDH\$R3	0.00 cs
EUDL\$R3	64.94 cs	EUDM\$R3	0.00 cs	EUDH\$R3	0.00 cs
ATWL\$R3	927.73 cs	ATWM\$R3	896.12 cs	ATWH\$R3	0.00 cs
TUDL\$R3	0.00 cs	TUDM\$R3	0.00 cs	TUDH\$R3	0.00 cs
MLL\$R3	915.04 cs	MLM\$R3	896.12 cs	MLH\$R3	0.00 cs
DTL\$R3	1.69 %	DTM\$R3	1.18 %	DTH\$R3	0.00 %

TABLE 3-8. VIDEO MONITOR PAGES 24, 25, 30

7m27-JUL-1987 13:21:04.51 IGSE USERS = 1 FLTAUTO - Col 11 PHOS 4 Pg24
 7mTLMID:16 PKTCT: 2 PSTAT:7F80 PKTMS:0004 TMAFC:509E FMODE:04 SRCCT: 34570
 7mArch: TLM IDL Time: 7.491 hrs Partitions: 3 Globals: 1609 20-MAY-87

*HVP1\$A4	0.5 v	*HVP6\$A4	0.0 v	PINON\$B4	off
*HVP2\$A4	0.0 v	*HVP7\$A4	0.0 v	PIN\$A4	5244.9 mv
*HVP3\$A4	0.0 v			AGCRA\$B4	1000
*HVP4\$A4	0.0 v	LEDON\$B4	off	AGCPS\$B4	normal
*HVP5\$A4	0.0 v	LED\$A4	3469.3 mv		
				PHGL\$B4	high
ELDL\$A4	79.4 mv	ELDM\$A4	79.4 mv	ELDH\$A4	79.4 mv
TLDL\$A4	100.1 mv	TLDM\$A4	100.1 mv	TLDH\$A4	98.9 mv
TUDL\$A4	4909.6 mv	TUDM\$A4	4904.8 mv	TUDH\$A4	4906.0 mv
ELDL\$R4	985.84 cs	ELDM\$R4	916.99 cs	ELDH\$R4	0.00 cs
EUDL\$R4	78.49 cs	EUDM\$R4	0.00 cs	EUDH\$R4	0.00 cs
ATWL\$R4	908.45 cs	ATWM\$R4	916.87 cs	ATWH\$R4	0.00 cs
TUDL\$R4	0.00 cs	TUDM\$R4	0.00 cs	TUDH\$R4	0.00 cs
MLL\$R4	886.84 cs	MLM\$R4	916.99 cs	MLH\$R4	0.00 cs
DTL\$R4	1.75 z	DTM\$R4	1.20 z	DTH\$R4	0.00 z

7m27-JUL-1987 13:32:26.54 IGSE USERS = 1 FLTAUTO - Col 11 DRIVECAL Pg25
 7mTLMID:16 PKTCT: 3 PSTAT:7F80 PKTMS:1EC4 TMAFC:51EB FMODE:04 SRCCT: 34903
 7mArch: TLM IDL Time: 7.294 hrs Partitions: 3 Globals: 1609 20-MAY-87

DEMG\$P	9999 Hex	FDET1\$P	0080 Hex	FDET2\$P	0080 Hex
		A1M\$A	6849.7 mv	A2M\$A	6743.8 mv
D1SA\$P	1627	A1R\$A	6849.7 mv	A2R\$A	6747.2 mv
D2SA\$P	1627	P1MZR\$A	6996.7 mv	P2MZR\$A	6996.7 mv
D3SA\$P	1612	P1RZR\$A	6996.7 mv	P2RZR\$A	6996.7 mv
D4SA\$P	1612	P1MXR\$A	5444.9 mv	P2MXR\$A	4276.0 mv
		P1RXR\$A	5468.9 mv	P2RXR\$A	4303.3 mv
IP1M\$A	6849.7 mv				
IP1R\$A	6849.7 mv	FDET3\$P	0080 Hex	FDET4\$P	0080 Hex
IP2M\$A	6743.8 mv	A3M\$A	6863.4 mv	A4M\$A	6801.9 mv
IP2R\$A	6747.2 mv	A3R\$A	6863.4 mv	A4R\$A	6795.0 mv
IP3M\$A	6863.4 mv	P3MZR\$A	6996.7 mv	P4MZR\$A	6996.7 mv
IP3R\$A	6863.4 mv	P3RZR\$A	6996.7 mv	P4RZR\$A	6996.7 mv
IP4M\$A	6801.9 mv	P3MXR\$A	5588.5 mv	P4MXR\$A	4891.2 mv
IP4R\$A	6795.0 mv	P3RXR\$A	5602.2 mv	P4RXR\$A	4833.1 mv

7m27-JUL-1987 13:22:10.51 IGSE USERS = 1 FLTAUTO - Col 11 PE ANA1 Pg30
 7mTLMID:16 PKTCT: 2 PSTAT:7F80 PKTMS:10C4 TMAFC:50BE FMODE:04 SRCCT: 34602
 7mArch: TLM IDL Time: 7.472 hrs Partitions: 3 Globals: 1609 20-MAY-87

MT1TM\$A	14.93 c	STRTM\$A	14.52 c	P1M\$A	6849.7 mv
MT5TM\$A	14.93 c	PRADC\$A	-32.76 c	P1MXR\$A	5444.9 mv
MT2TM\$A	14.93 c	MRADC\$A	-32.76 c	P1MZR\$A	6996.7 mv
MT6TM\$A	14.93 c	MYLTM\$A	-33.45 c	P2M\$A	6743.8 mv
MT3TM\$A	15.23 c	NOMTM\$A	-33.45 c	P2MXR\$A	4276.0 mv
MT7TM\$A	15.23 c	ST1TM\$A	14.42 c	P2MZR\$A	6996.7 mv
MT4TM\$A	15.33 c	ST2TM\$A	14.52 c	P3M\$A	6863.4 mv
MT8TM\$A	15.43 c	ST3TM\$A	14.42 c	P3MXR\$A	5588.5 mv
PETM\$A	17.06 c	ST4TM\$A	14.52 c	P3MZR\$A	6996.7 mv
PEPTM\$A	18.85 c	PE5V\$A	4.969 v	P4M\$A	6801.9 mv
CPMTM\$A	16.40 c	PE10V\$A	10.605 v	P4MXR\$A	4891.2 mv
DRETM\$A	15.52 c	PE20V\$A	21.273 v	P4MZR\$A	6996.7 mv
PCUTM\$A	18.85 c	PN10V\$A	-10.595 v		
MTRAT\$A	17.79 c	*CPMR\$A	-30.7 mv		
MTRBT\$A	16.21 c	HVCPM\$A	799.8 v		

TABLE 3-9. VIDEO MONITOR PAGES 31, 32, 34

7m27-JUL-1987 13:22:35.20 IGSE USERS = 1 FLTAUTO - Col 11 PE ANA2 Pg31
 7mTLMID:16 PKTCT: 2 PSTAT:7F80 PKTMS:0384 TMAFC:50CA FMODE:04 SRCCT: 34614
 7mArch: TLM IDL Time: 7.465 hrs Partitions: 3 Globals: 1609 20-MAY-87

PE5C\$A	2.861 a	CPUC\$A	398.8 ma	*MTD4C\$A	-0.001 a
PE10C\$A	78.2 ma	MTRAC\$A	0.016 a	MTD4F\$A	22.204 v
PE20C\$A	5.9 ma	MTRAF\$A	27.628 v	TD1F\$A	22.219 v
P1R\$A	6853.2 mv	MTRBC\$A	0.010 a	*MTD5F\$A	-0.015 v
P1RXR\$A	5468.9 mv	MTRBF\$A	27.648 v	*TD2F\$A	-0.015 v
P1RZR\$A	6996.7 mv	CEAC\$A	0.864 a	*MTD6F\$A	-0.015 v
P2R\$A	6747.2 mv	CEAV\$A	27.979 v	*TD3F\$A	-0.015 v
P2RXR\$A	4303.3 mv	CEBC\$A	0.009 a	*MTD7F\$A	-0.015 v
P2RZR\$A	6996.7 mv	CEBV\$A	27.626 v	*MTD8F\$A	-0.015 v
P3R\$A	6863.4 mv	*MTD1C\$A	-0.001 a	TD4F\$A	22.219 v
P3RXR\$A	5602.2 mv	MTD1F\$A	22.218 v	QBV\$A	27.608 v
P3RZR\$A	6996.7 mv	*MTD2C\$A	-0.001 a		
P4R\$A	6795.0 mv	MTD2F\$A	22.205 v		
P4RXR\$A	4833.1 mv	*MTD3C\$A	-0.001 a		
P4RZR\$A	6996.7 mv	MTD3F\$A	22.249 v		

7m27-JUL-1987 13:22:53.76 IGSE USERS = 1 FLTAUTO - Col 11 PE ANA3 Pg32
 7mTLMID:16 PKTCT: 3 PSTAT:7F80 PKTMS:1104 TMAFC:50D3 FMODE:04 SRCCT: 34623
 7mArch: TLM IDL Time: 7.460 hrs Partitions: 3 Globals: 1609 20-MAY-87

DET1F\$A	28.062 v	*AHT2C\$A	-0.013 a	MHTCF\$A	28.731 v
DET1C\$A	0.549 a	*AHT2F\$A	-0.020 v	MUBV\$A	28.652 v
DET2F\$A	28.121 v	*AHT3C\$A	-0.008 a		
DET2C\$A	0.557 a	*AHT3F\$A	-0.020 v		
DET3F\$A	28.141 v	*AHT4C\$A	-0.014 a		
DET3C\$A	0.560 a	*AHT4F\$A	-0.020 v		
DET4F\$A	28.161 v	*MHT1C\$A	-0.002 a		
DET4C\$A	0.550 a	MHT1F\$A	28.750 v		
AGCAB\$S	4AC0 Hex	*MHT2C\$A	-0.005 a		
PL5V\$A	4.905 v	MHT2F\$A	28.672 v		
PL10V\$A	10.457 v	*MHT3C\$A	-0.003 a		
PLN10\$A	-10.413 v	MHT3F\$A	28.750 v		
*TBV\$A	-0.020 v	*MHT4C\$A	-0.002 a		
*AHT1C\$A	-0.011 a	MHT4F\$A	28.750 v		
*AHT1F\$A	-0.020 v	*MHTCC\$A	-0.002 a		

7m27-JUL-1987 13:23:19.92 IGSE USERS = 1 FLTAUTO - Col 11 DEL 2PWR Pg34
 7mTLMID:16 PKTCT: 4 PSTAT:7F80 PKTMS:0544 TMAFC:50EO FMODE:04 SRCCT: 34636
 7mArch: TLM IDL Time: 7.453 hrs Partitions: 3 Globals: 1609 20-MAY-87

V10\$A1	10.057 v	MTD1F\$A	22.218 v	V10\$A2	10.052 v
V10C\$A1	379.4 ma	*MTD1C\$A	-0.001 a	V10C\$A2	384.8 ma
V12\$A1	11.414 v	*MTD5F\$A	-0.015 v	*V12\$A2	11.396 v
V12C\$A1	171.8 ma			V12C\$A2	170.7 ma
*V20\$A1	20.887 v	*AHT1F\$A	-0.020 v	*V20\$A2	20.904 v
V20C\$A1	15.2 ma	*AHT1C\$A	-0.011 a	V20C\$A2	17.7 ma
V5\$A1	5.127 v			V5\$A2	5.115 v
V5C\$A1	326.7 ma			V5C\$A2	322.1 ma
VN10\$A2	-9.764 v			VN10\$A3	-9.749 v
VN10C\$A2	429.8 ma	MTD2F\$A	22.220 v	VN10C\$A3	428.5 ma
MHT1F\$A	28.750 v	*MTD2C\$A	-0.001 a	MHT2F\$A	28.672 v
*MHT1C\$A	-0.002 a	*MTD6F\$A	-0.015 v	*MHT2C\$A	-0.005 a
DET1F\$A	28.062 v			DET2F\$A	28.121 v
DET1C\$A	0.548 a	*AHT2F\$A	-0.020 v	DET2C\$A	0.558 a
		*AHT2C\$A	-0.013 a		

TABLE 3-10. VIDEO MONITOR PAGES 35, 36, 42

7m27-JUL-1987 13:23:37.74 IGSE USERS = 1 FLTAUTO - Col 11 VOPP Pg35
 7mTLMID:16 PKTCT: 1 PSTAT:7F80 PKTMS:12C4 TMAFC:50E9 FMODE:04 SRCCT: 34645
 7mArch: TLM IDL Time: 7.449 hrs Partitions: 3 Globals: 1609 20-MAY-87

S1LD\$R1	0.00 cs	S1LD\$R3	0.00 cs	VOPP\$B2	off
S2LD\$R1	0.00 cs	S2LD\$R3	0.00 cs	VOPP\$B3	off
S3LD\$R1	0.00 cs	S3LD\$R3	0.00 cs	VOPP\$B4	off
S4LD\$R1	0.00 cs	S4LD\$R3	0.00 cs	VOPP1\$P	0000 Hex
SMD\$R1	0.00 cs	SMD\$R3	0.00 cs		
SUD\$R1	0.00 cs	SUD\$R3	0.00 cs	VOPP2\$P	0000 Hex
				VOPP3\$P	0000 Hex
S1LD\$R2	0.00 cs	S1LD\$R4	0.00 cs	VOPP4\$P	0000 Hex
S2LD\$R2	0.00 cs	S2LD\$R4	0.00 cs	VRPH\$B1	anti
S3LD\$R2	0.00 cs	S3LD\$R4	0.00 cs		
S4LD\$R2	0.00 cs	S4LD\$R4	0.00 cs		
SMD\$R2	0.00 cs	SMD\$R4	0.00 cs		
SUD\$R2	0.00 cs	SUD\$R4	0.00 cs		

7m27-JUL-1987 13:23:54.98 IGSE USERS = 1 FLTAUTO - Col 11 FLTAUTO Pg36
 7mTLMID:16 PKTCT: 1 PSTAT:7F80 PKTMS:1EC4 TMAFC:50F1 FMODE:04 SRCCT: 34653
 7mArch: TLM IDL Time: 7.444 hrs Partitions: 3 Globals: 1609 20-MAY-87

C6TMP\$A1	14.77 c	MLL\$R1	920.04 cs	PTMP1\$A1	14.85 c
C6TMP\$A2	14.88 c	MLL\$R2	950.68 cs	PTMP1\$A2	15.03 c
C6TMP\$A3	14.81 c	MLL\$R3	942.63 cs	PTMP1\$A3	14.77 c
C6TMP\$A4	14.96 c	MLL\$R4	919.80 cs	PTMP1\$A4	15.03 c

7m27 JUL-1987 13:24:24.97 IGSE USERS = 1 FLTAUTO - Col 11 CO60 Pg42
 7mTLMID:16 PKTCT: 4 PSTAT:7F80 PKTMS:1604 TMAFC:5100 FMODE:04 SRCCT: 34668
 7mArch: TLM IDL Time: 7.434 hrs Partitions: 3 Globals: 1609 20-MAY-87

C6LDSA1	89.0 mv	C6LDSR1	0. cs	DTL\$R1	1.73 Z
C6LDSA2	89.0 mv	C6LDSR2	0. cs	DTL\$R2	1.71 Z
C6LDSA3	89.0 mv	C6LDSR3	0. cs	DTL\$R3	1.70 Z
C6LDSA4	89.0 mv	C6LDSR4	0. cs	DTL\$R4	1.73 Z
*HVC6\$A1	0.0 v	VC6\$B1	on		
*HVC6\$A2	0.0 v	VC6\$B2	on		
*HVC6\$A3	0.0 v	VC6\$B3	on		
*HVC6\$A4	0.0 v	VC6\$B4	on		

TABLE 3-11. VIDEO MONITOR PAGE 43

7m27--JUL--1987 13:24:42.40 IGSE USERS = 1 FLTAUTO - Col 11 SHIELDS Pg43
 7mILMID:16 PKTCT: 4 PSTAT:7F80 PKTMS:02C4 TMAFC:5108 FMODE:04 SRCCT: 34676
 7mArch: TLM IDL Time: 7.429 hrs Partitions: 3 Globals: 1609 20-MAY-87

S1LD\$R1	0.00 cs	S1LD\$R2	0.00 cs	DTL\$R1	1.61 Z
S2LD\$R1	0.00 cs	S2LD\$R2	0.00 cs		
S3LD\$R1	0.00 cs	S3LD\$R2	0.00 cs	DTL\$R2	1.59 Z
S4LD\$R1	0.00 cs	S4LD\$R2	0.00 cs		
SMD\$R1	0.00 cs	SMD\$R2	0.00 cs	DTL\$R3	1.59 Z
SUD\$R1	0.00 cs	SUD\$R2	0.00 cs		
				DTL\$R4	1.61 Z
S1LD\$R3	0.00 cs	S1LD\$R4	0.00 cs		
S2LD\$R3	0.00 cs	S2LD\$R4	0.00 cs		
S3LD\$R3	0.00 cs	S3LD\$R4	0.00 cs		
S4LD\$R3	0.00 cs	S4LD\$R4	0.00 cs		
SMD\$R3	0.00 cs	SMD\$R4	0.00 cs		
SUD\$R3	0.00 cs	SUD\$R4	0.00 cs		

3.2 DRIVE POTENTIOMETER CALIBRATION CURVES

Figures 3-1 through 3-4 are Main Pot SYSPOTLIN values for Processor Electronics, A-side (PEA). These tests were performed on 25 March 1987, during Thermal-Vacuum testing of OSSE.

Figures 3-5 through 3-8 are Redundant Pot SYSPOTLIN values for Processor Electronics, A-side (PEA). These tests were also performed on 25 March 1987, during the Thermal-Vacuum testing of OSSE.

FIGURE 3-1. SYSPOTLIN, DETECTOR A1, PROCESSOR ELECTRONICS A
MAIN POT

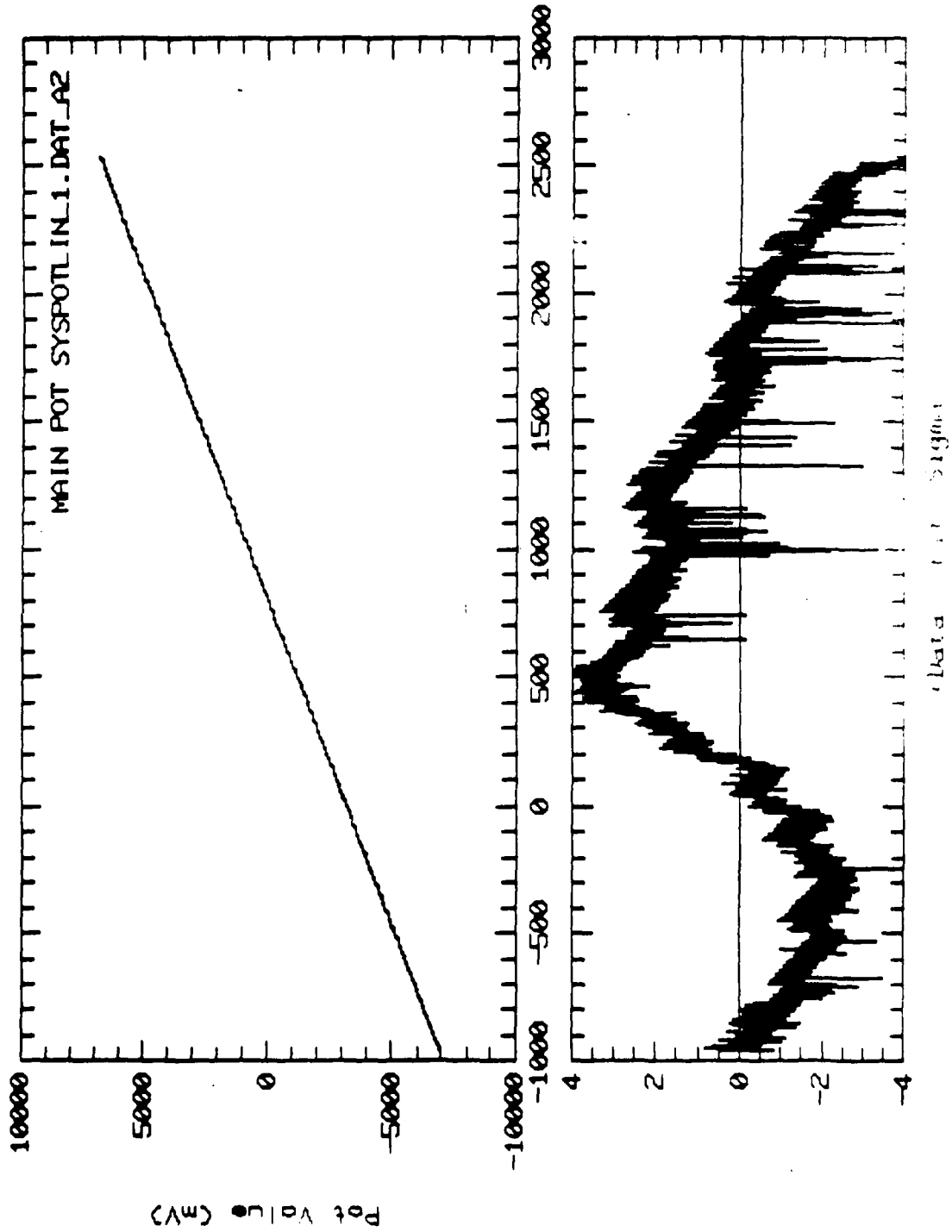

FIGURE 3-2. SYSPOTLIN, DETECTOR A2, PROCESSOR ELECTRONICS A
MAIN POT

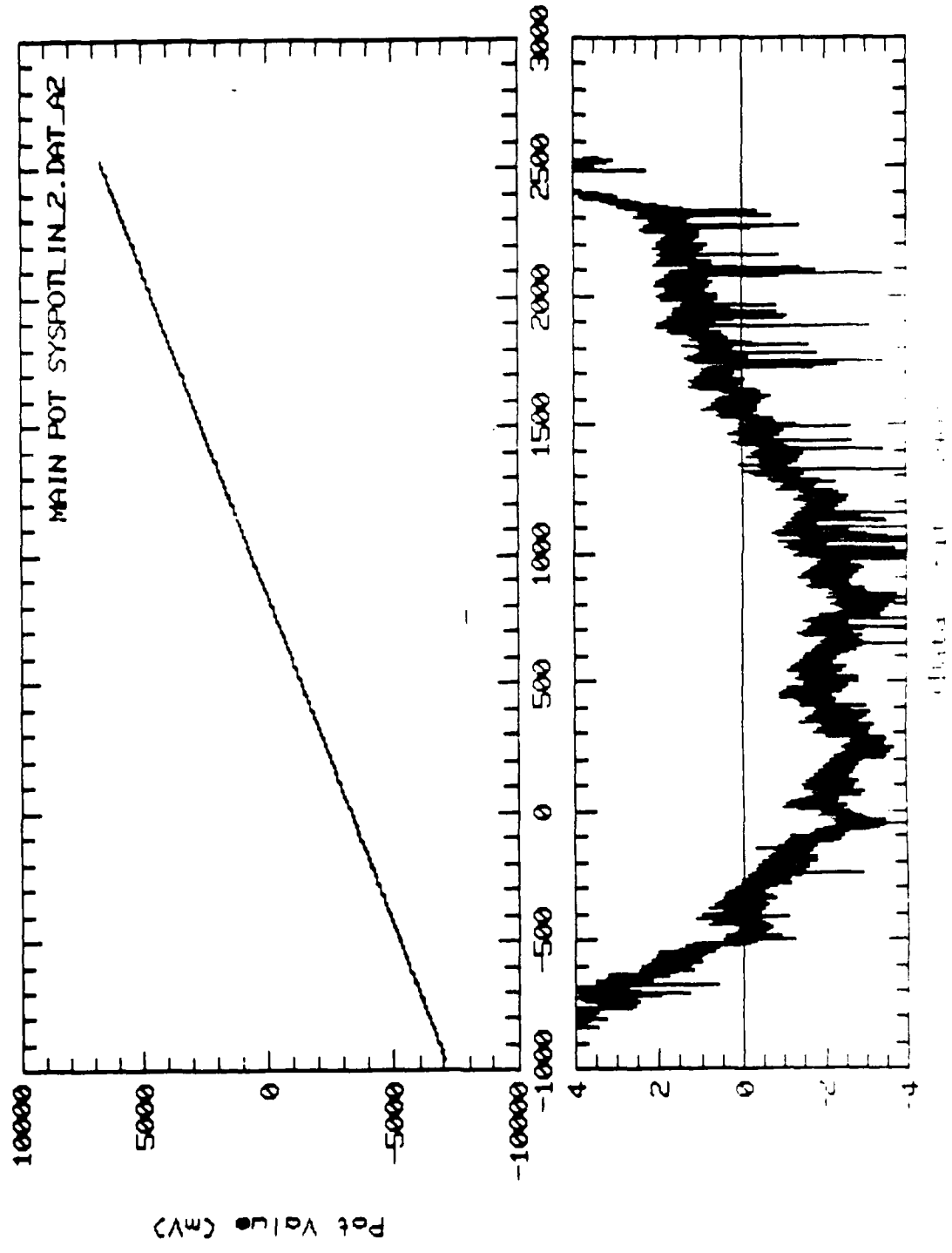

FIGURE 3-3. SYSPOTLIN, DETECTOR A3, PROCESSOR ELECTRONICS A
MAIN POT

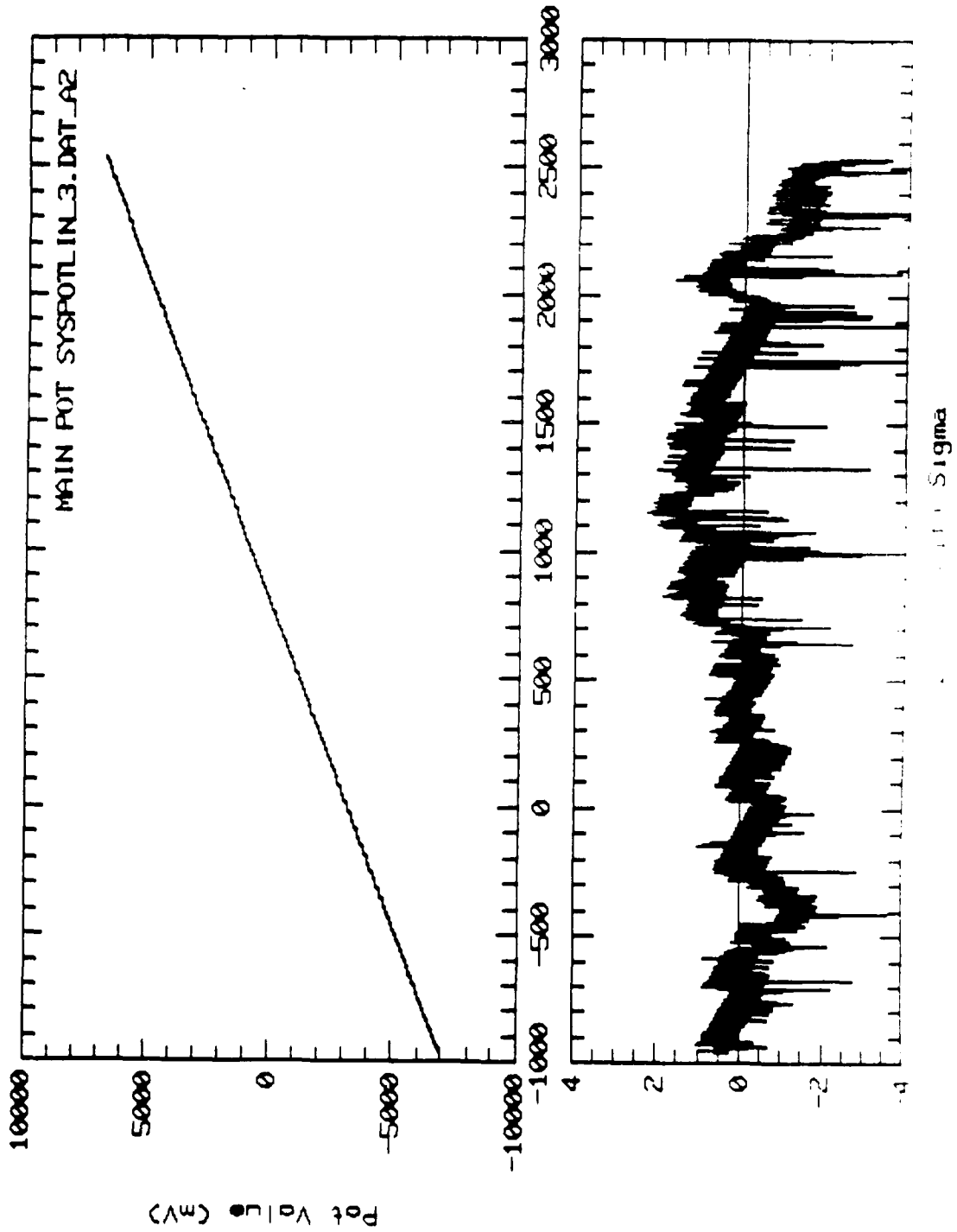

FIGURE 3-4. SYSPOTLIN, DETECTOR A4, PROCESSOR ELECTRONICS A
MAIN POT

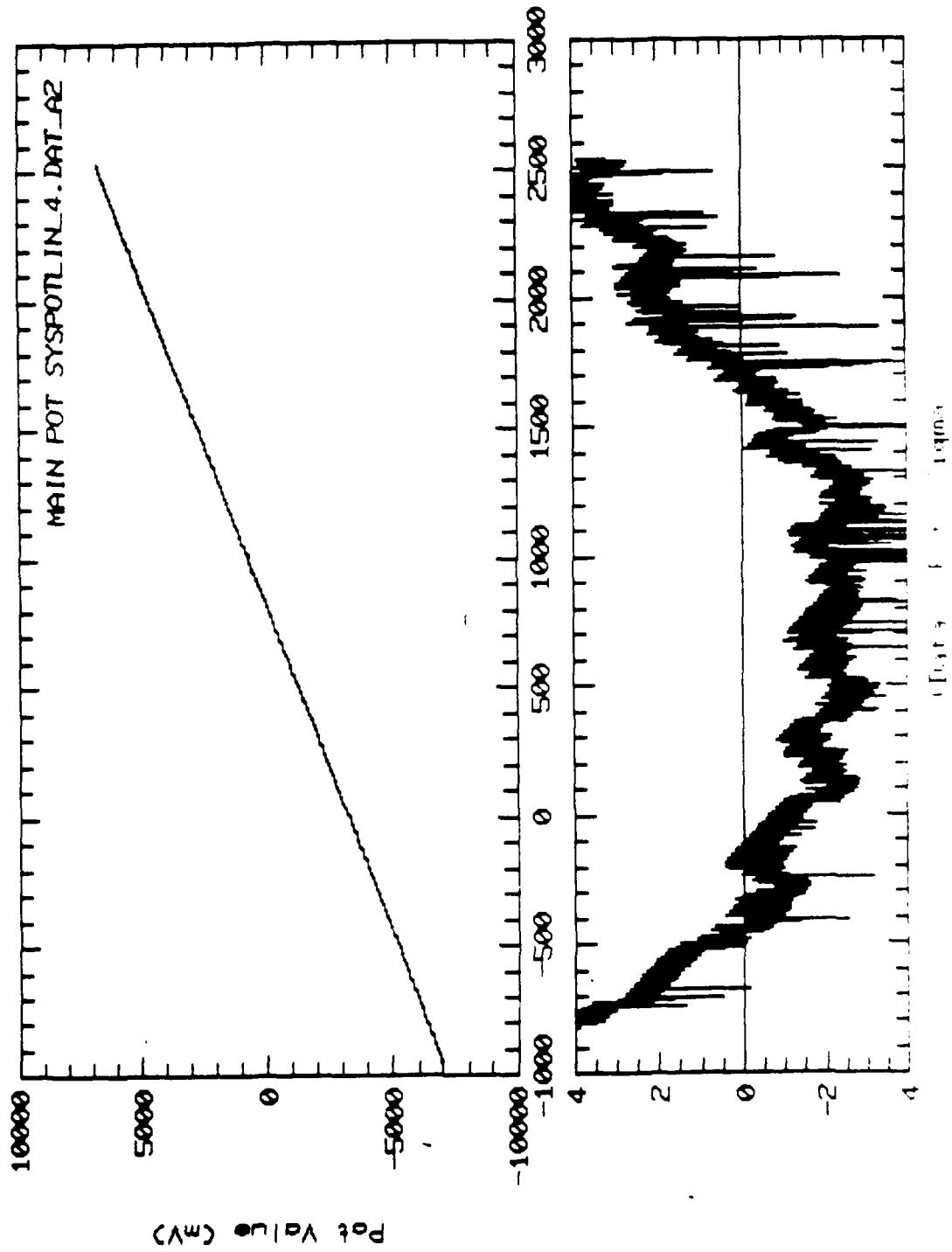

FIGURE 3-5. SYSPOTLIN, DETECTOR A1, PROCESSOR ELECTRONICS A
REDUNDANT POT

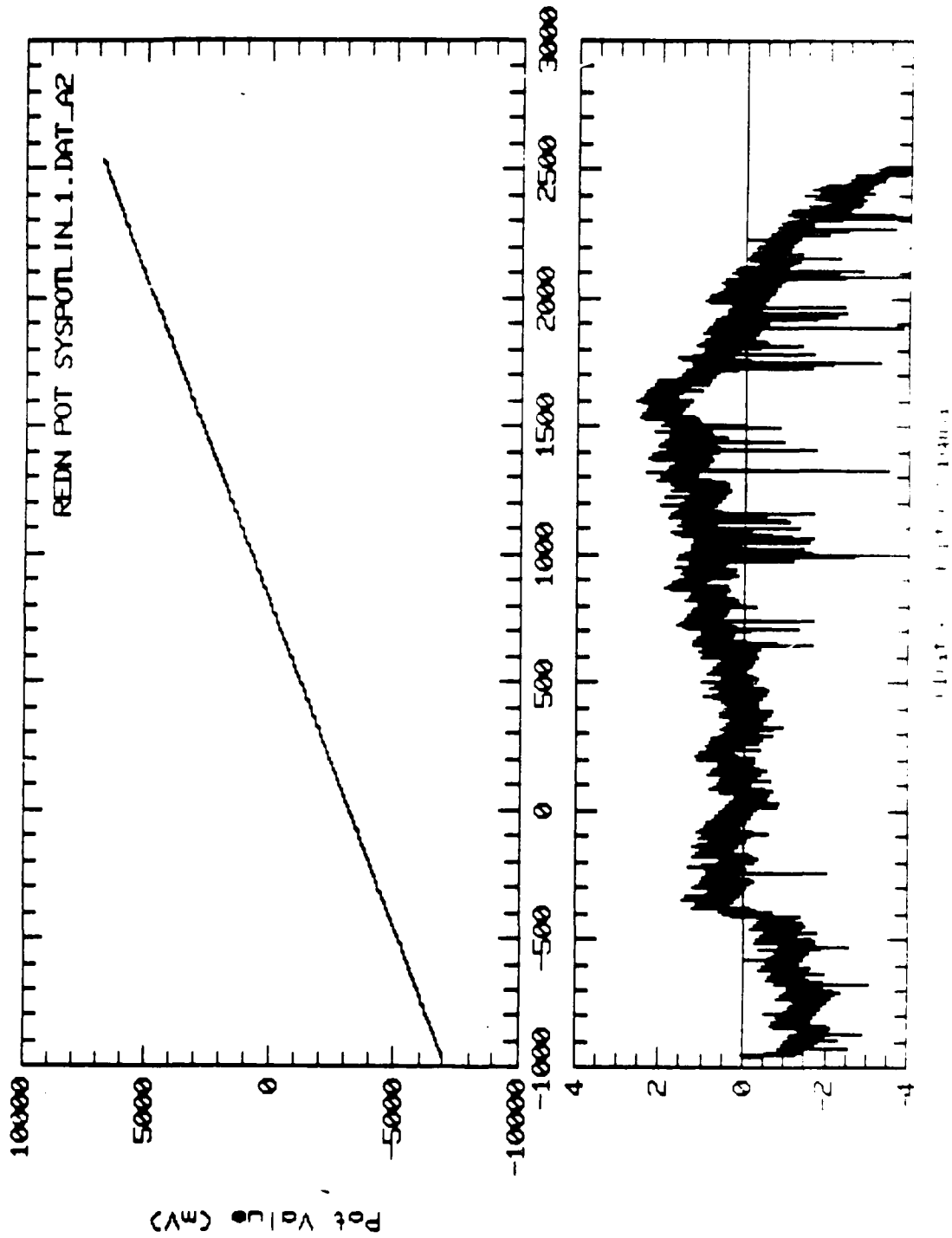

FIGURE 3-6. SYSPOTLIN, DETECTOR A2, PROCESSOR ELECTRONICS A
REDUNDANT POT

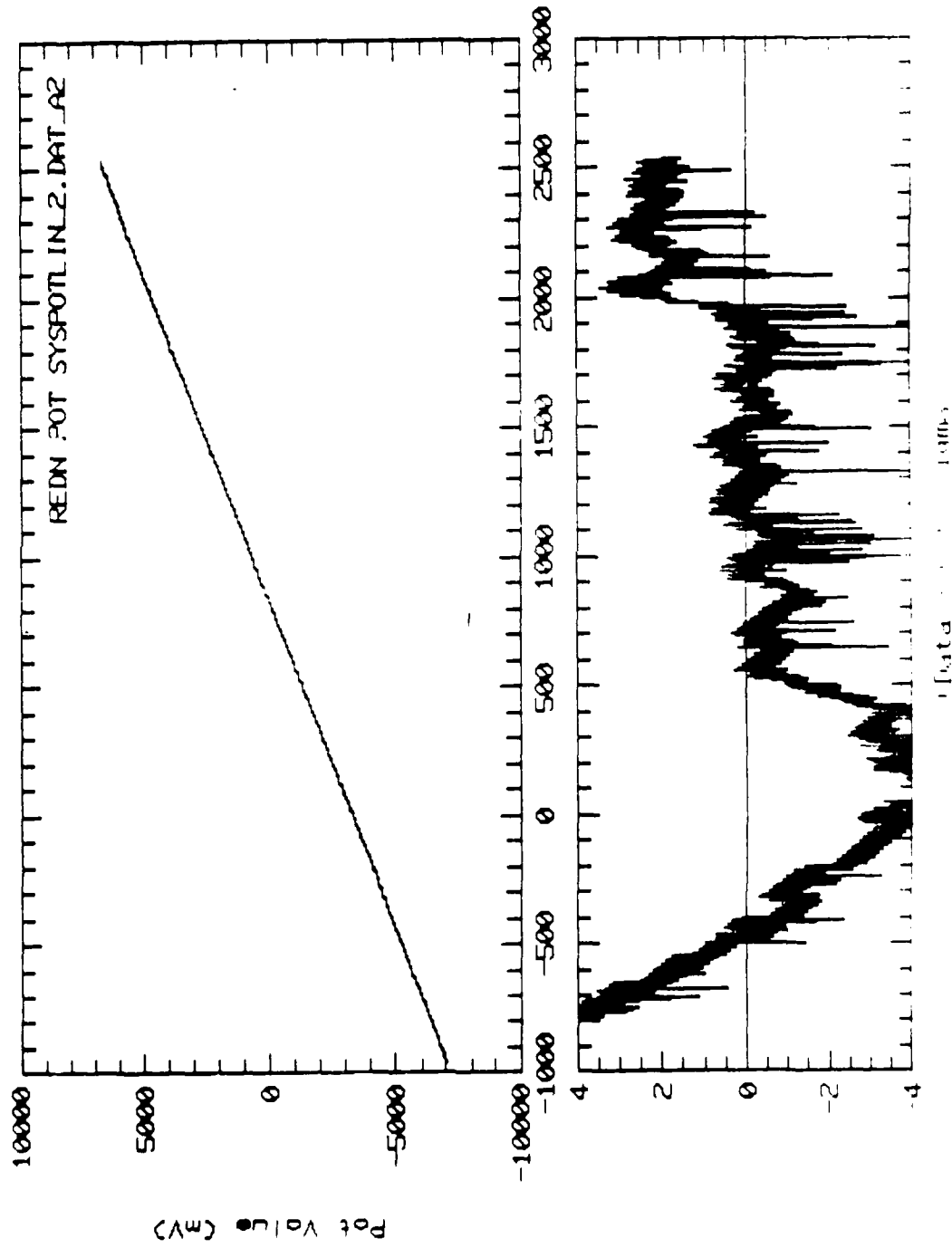

FIGURE 3-7. SYSPOTLIN, DETECTOR A3, PROCESSOR ELECTRONICS A
REDUNDANT POT

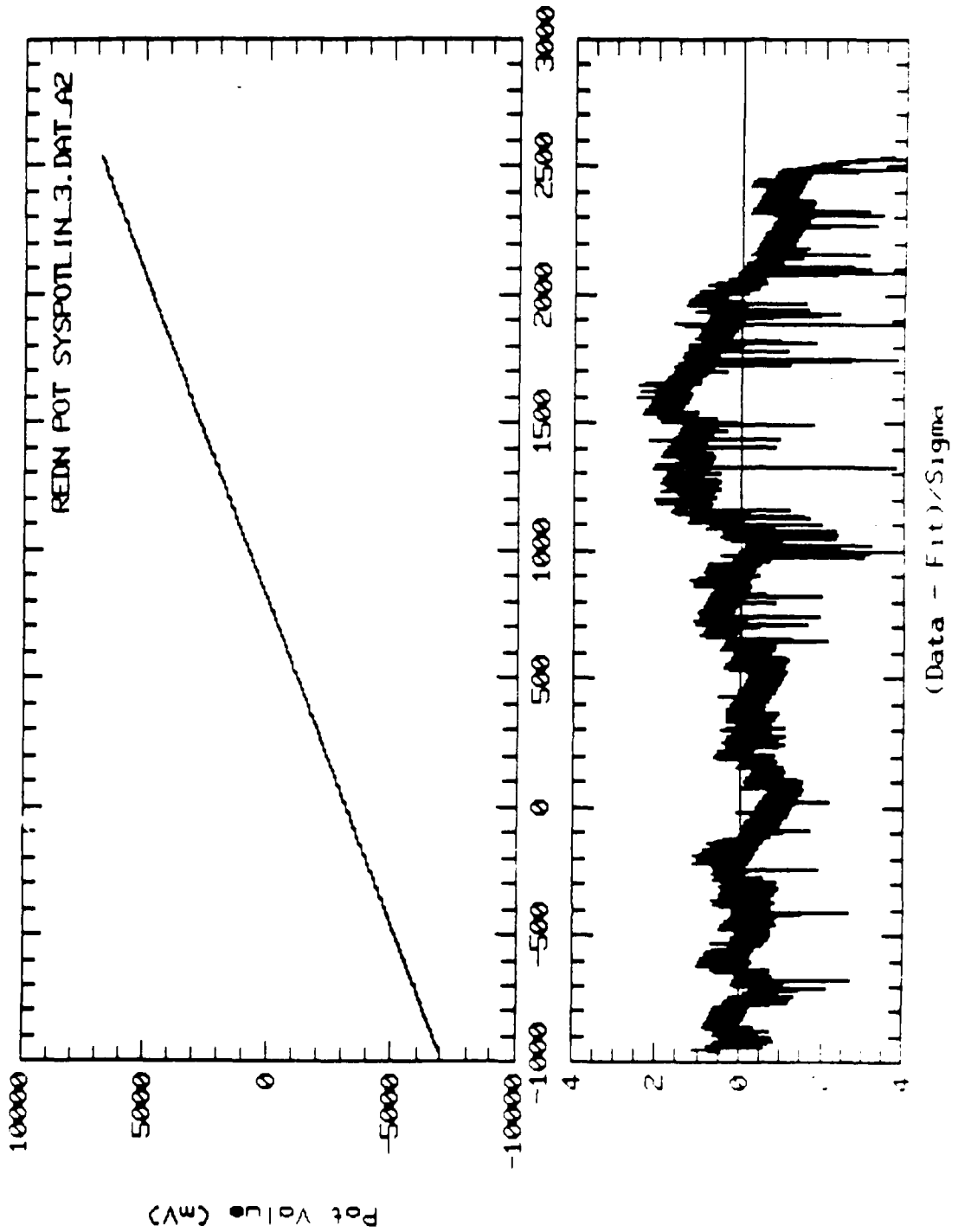
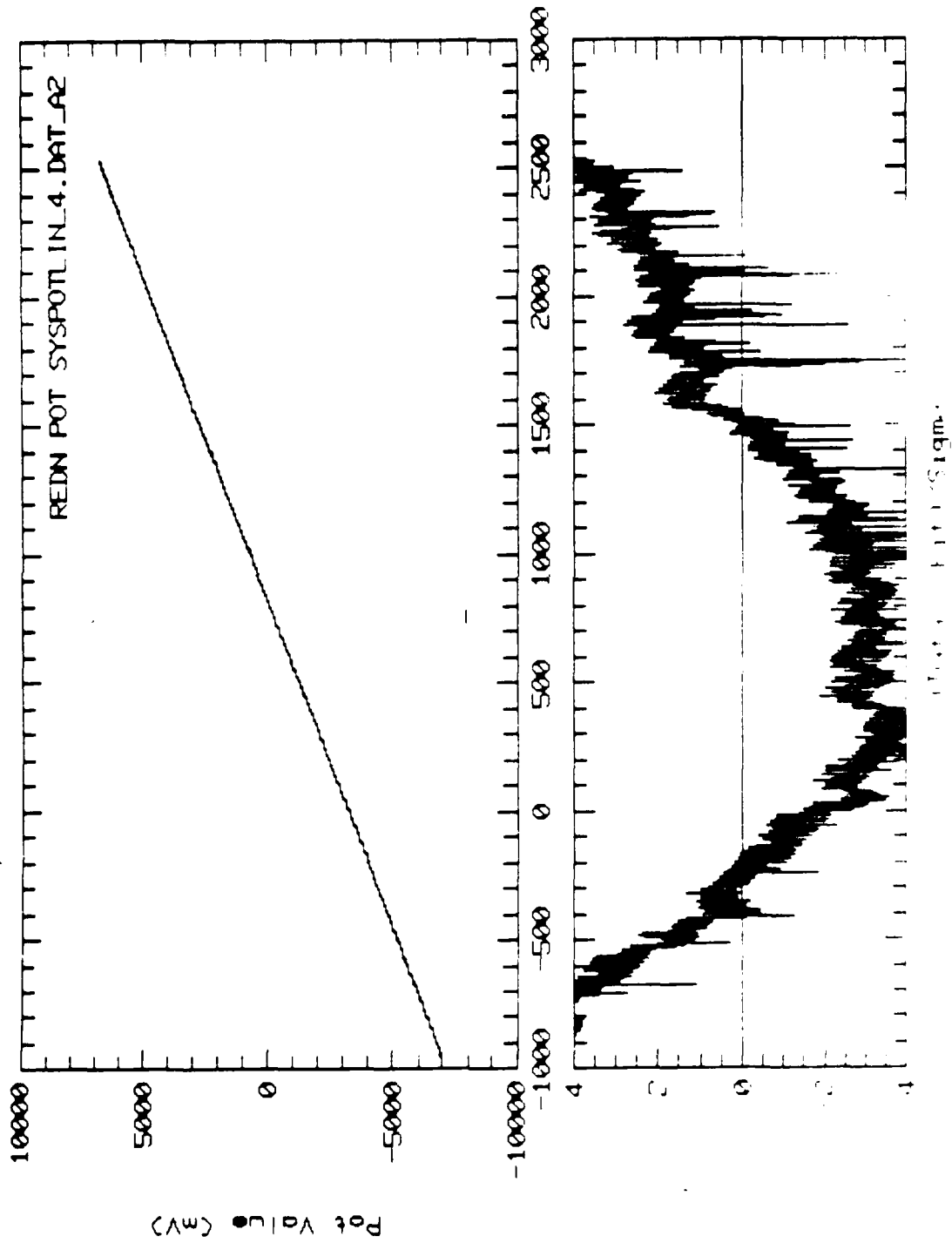

FIGURE 3-8. SYSPOTLIN, DETECTOR A4, PROCESSOR ELECTRONICS A
REDUNDANT POT



3.3 OSSE POWER CONSUMPTION SUMMARY

TABLE 3-12 QUIET BUS CURRENT (AMPS) AND POWER (WATTS)

CONFIGURATION	22 VOLTS	28 VOLTS	35 VOLTS
CE A, MOTOR REG B	1.07 (23.5)	0.86 (24.1)	0.70 (24.5)
CE A, MOTOR REG B 4 DETECTORS ON (HIGH VOLTS OFF)	3.97 (87.3)	3.10 (86.8)	2.51 (87.8)
CE A, MOTOR REG B 4 DETECTORS ON (HIGH VOLTS ON)	4.42 (97.2)	3.46 (96.9)	2.77 (97.0)
CE A, MOTOR REG B 4 DETECTORS ON 4 DRIVES ON	5.14 (113.1)	4.02 (112.6)	3.25 (113.8)
CE A, MOTOR REG B 4 DETECTORS ON, 5% DRIVE DUTY CYCLE (AVERAGE POWER, CALCULATED)	4.46 (98.0)	4.05 (97.7)	2.80 (97.9)
CE A, MOTOR REG B 4 DETECTORS ON, ONE SECOND MOTOR HOLD PULSE ON ALL DRIVES (ESTIMATE)	(129)	(129)	(129)

TABLE 3-13 MAKEUP BUS CURRENT (AMPS) AND POWER (WATTS)

CONFIGURATION	22 VOLTS	25 VOLTS	28 VOLTS	35 VOLTS
4 DETECTOR MAKEUP HEATERS ON	2.46 (54.1)	2.84 (71.0)	3.18 (89.0)	3.92 (137.2)
CE MAKEUP HEATER ON	0.83 (18.2)	0.92 (23.0)	1.05 (29.5)	1.32 (46.1)
4 DETECTOR AND CE MAKEUP HEATERS ON	3.27 (71.9)	3.73 (93.2)	4.17 (116.8)	5.20 (182.0)
NO MAKEUP HEATERS ON			17.4 MA (0.49)	

TABLE 3-14 THERMAL BUS CURRENT (AMPS) AND POWER (WATTS)

CONFIGURATION	21 VOLTS	28 VOLTS	35 VOLTS
4 DETECTOR ACTIVE HEATERS FULLY ON, HEATER POWER	4.05 (85.1)	3.04 (85.1)	2.43 (85.1)
4 DETECTOR ACTIVE HEATERS FULLY ON, CONTROL CIRCUIT POWER	0.45 (9.4)	0.34 (9.6)	0.28 (9.9)
4 DETECTOR ACTIVE HEATERS FULLY ON, TOTAL BUS POWER	4.50 (94.5)	3.38 (94.7)	2.72 (95.0)

3.4 ALIGNMENT SUMMARY (MECHANICAL, PRE-CALIBRATION)

Alignment, for OSSE and most complex space systems, is easy to define as an objective, but difficult to explain as a procedure. This report attempts to define the requirements in terms of arc minute errors and uncertainties in the alignment of appropriate system components, state actual errors, then provide supporting evidence that these measured errors are within the uncertainty budget.

1.0 ALIGNMENT REQUIREMENTS

- a) The center of the field of view (FOV) for each detector shall be known to within six arc minutes (three arc minutes allotted to internal OSSE alignment uncertainty of the detector FOV to the mounting surface in the X-Z (scan) plane), and known to within eight arc minutes in the perpendicular direction (five arc minutes allotted to internal OSSE alignment uncertainty of the detector FOV to the mounting surface in the X-Z (scan) plane. Ref ICD 1135G, and SEM 926-061A.
- b) The center of a detector's FOV relative to the crystal housing must have an uncertainty less than or equal to one arc minute in the X-Z scan direction and three arc minutes in the perpendicular direction. Ref SEM 926-061A.
- c) Each detector subsystem must be positioned in the structure so that its rotation axis is within three arc minutes of the OSSE Y axis defined by the optical reference cube (known to less than one arc minute). Ref SEM 926-061A.
- d) The center of the field of view of each collimator must be determined with an uncertainty of less than plus or minus one arc minute in the X-Z scan direction and to less than plus or minus three arc minutes in the perpendicular direction. Since determination of the gamma ray field of view is a primary objective of the post-acceptance calibration, this report considers only the geometric center of the field of view using mechanical measurement methods. Ref SEM 926-061A.
- e) The motor step count and absolute drive position must be verifiable. Ref SEM 926-061A.

1.1 Methods

Items a) through e) range from an overall uncertainty requirement for each detector's field of view with respect to the OSSE structure, to the uncertainty associated with each detector collimator. Measurements for alignment went in two separate directions:

1. From collimator FOV to detector housing, by means of an alignment cube, for each of the four units.

Test Procedure 150689, OSSE COLLIMATOR DETECTOR ALIGNMENT MEASUREMENTS, was a post-fabrication optical survey of each collimator to determine a three-sigma confidence in the plane-parallelism of the four sets of walls, the select wall in each set which corresponds closest to the mean, then compensating for wall taper, and establishing an external reference

(in the form of an optical reference cube) corresponding to the median planes between opposing mean walls for both X-facing and Y-facing wall pair-sets. It was intended to be a mechanical starting point from which (primarily) a zero step reference could be established for various assembly and calibration tests of OSSE. Since the insertion of the collimator into the detector housing was done without provision for collimator orientation adjustment, the reference cube provides an indication of where the gamma ray axis is expected to be with respect to primary instrument axes, and the zero-reference step. As OSSE undergoes source mapping during the final calibration phase, the gamma ray axes are then established with respect to the primary instrument and detector references, and the opto-mechanical measurements of DD150689 become obsolete. The optical cubes placed on the detectors may still be used as an index for rotation angle position and stability, and to cross-check the actual gamma ray field of view center with the expected center. The opto-mechanical measurements and their uncertainties are addressed in this report as part of the initial requirements.

2. From structure mounting points to each of four detector rotation axes by means of structure alignment cube referenced to the X-Y mounting surface axes.

The rotation axis of each detector was established in reference to the OSSE mounting holes. This was done as described in SER EX056-017. After the mounting holes were drilled in the handling dolly by means of a drill template (which is retained at TRW for spacecraft integration), conical-tipped tooling pins were placed over the +X-Y, -X-Y, and +X+Y mounting holes of the dolly, then surveyed with a T-3 theodolite. The dolly reference cube was mounted to the reference established by the bolt holes and the drill template cube was also mounted to the template parallel to the dolly cube while the template was attached to the dolly. The template was then shipped to TRW. THE ESTIMATED UNCERTAINTY OF THE DOLLY CUBE POSITION IS ABOUT 0.3 ARC MINUTES. The flight structure was eventually mounted on the dolly, and two alignment cubes mounted to the center structure, one being the OSSE assembly alignment cube set identically to the dolly reference cube from which all instrument pointing errors were measured during assembly, test, and calibration, WHOSE ESTIMATED UNCERTAINTY WITH RESPECT TO THE DOLLY CUBE IS 0.2 ARC MINUTES. The other was the Instrument alignment, or TRW, cube, a 45 degree Z-axis-rotated cube required by the ICD for spacecraft assembly (SER EX056A-267A describes the placement method of this cube). The TRW cube was referenced off the OSSE assembly cube. THE UNCERTAINTY OF THE INSTALLATION OF THE TRW CUBE IS APPROXIMATELY 1 ARC MINUTE WITH RESPECT TO THE OSSE CUBE.

However, because of the long period elapsed since the installation of the TRW cube during which no checks were made on its alignment (none required for assembly purposes), this cube should be checked against the OSSE reference cube as one of the last steps prior to placement on GRO. The TRW cube is bonded and mechanically clamped in place, and movement is unlikely, but a final check would be comforting.

Final measurements of each detector FOV with respect to the mounting configuration and drive reference were made once the detectors were mounted on the structure..

1.2 Final Results

Test Procedure DD150711, FIELD OF VIEW, measured the work done in DD150689 on the collimator/detector subsystems, SER EX056-017 alignment procedure, and DD150711 drive calibration. The following tables are a summary of the errors and uncertainties of OSSE:

TABLE 3-15
ALIGNMENT ERROR BUDGET VS
ALIGNMENT ACHIEVED
DETECTOR FIELD OF VIEW

This table relates the DETECTOR FIELD OF VIEW to the DETECTOR ROTATION AXIS. Numbers with parenthesis are forecast per SER EX056-017. Those numbers without parenthesis are measured or estimated on the basis of observation or calculation. All values in arc minutes.

DETECTOR 1 (-X,-Y) Alignment Item	Uncertainty (3 sigma)		Error (3 sigma)	
	Scan	Cross-Scan	Scan	Cross-Scan
Collimator	(0.8) 0.58	(2.06) 1.45	0	1.3 *
Collimator/ Detector Cube	(0.67) 0.67	(0.67) 0.67		
Drive Backlash	(2.43) 2.43	- -		
Pot Zero/Nearest Step	(0.49) 0.49	- -		
Gravity Deform- ation	(0.20) 0.20	(0.20) 0.20		
Thermal Deform- ation	(0.11) 0.11	(0.11) 0.11		
Alignment Cube Fabrication (3 cubes)	(0.17) 0.17 (0.17) 0.17 (0.17) 0.17	(0.17) 0.17 (0.17) 0.17 (0.17) 0.17		
Alignment Cube Measurements (4 measurements)	(0.05) 0.05 (0.05) 0.05 (0.05) 0.05	(0.05) 0.05 (0.05) 0.05 (0.05) 0.05		
	RSS (2.67) 2.66	RSS (2.20) 1.64	Arithmetic -	1.3

* No Specification

TABLE 3-16

ALIGNMENT ERROR BUDGET VS
ALIGNMENT ACHIEVED:
DETECTOR ROTATION AXIS

This table relates the DETECTOR ROTATION AXIS to the OSSE Y-AXIS. Numbers with parenthesis are those forecast per SER EX056-017. The numbers without parenthesis are those actually measured. All values in arc minutes.

DETECTOR 2 (-X,-Y) Alignment Item	Uncertainty (3 sigma)		Error (3 sigma)	
	Scan	Cross-Scan	Scan	Cross-Scan
Detector Rotation Axis (10 translation measurements)	-	(.16)	-	(2.53)

The effect of Detector Rotation Axis errors may add, or subtract, from the overall OSSE instrument pointing accuracy. The contribution depends on the detector position angle, and the sign of the error values with respect to instrument coordinate convention (Theta definitions). See Figures 1 and 5.

TABLE 3-17
ALIGNMENT ERROR BUDGET VS
ALIGNMENT ACHIEVED

This table relates the DETECTOR FIELD OF VIEW to the DETECTOR ROTATION AXIS. Numbers with parenthesis are those forecast per SER EX056-017. The numbers without parenthesis are those measured or estimated on the basis of observation or calculation.

DETECTOR 2 (-X,+Y) Alignment Item	Uncertainty (3 sigma)		Error (3 sigma)	
	Scan	Cross-Scan	Scan	Cross-Scan
Collimator	(0.8) 0.33	(2.06) 0.32	0	7.15 *
Collimator/ Detector Cube	(0.67) 0.67	(0.67) 0.67		
Drive Backlash	(2.43) 2.00	- -		
Pot Zero/Nearest Step	(0.49) 0.49	- -		
Gravity Deform- ation	(0.20) 0.20	(0.20) 0.20		
Thermal Deform- ation	(0.11) 0.11	(0.11) 0.11		
Alignment Cube Fabrication (3 cubes)	(0.17) 0.17 (0.17) 0.17 (0.17) 0.17	(0.17) 0.17 (0.17) 0.17 (0.17) 0.17		
Alignment Cube Measurements (4 measurements)	(0.05) 0.05 (0.05) 0.05 (0.05) 0.05	(0.05) 0.05 (0.05) 0.05 (0.05) 0.05		
RSS Sum	(2.67) 2.22	(2.20) 0.64		

* No specification

TABLE 3-18

ALIGNMENT ERROR BUDGET VS
ALIGNMENT ACHIEVED:
DETECTOR ROTATION AXIS

This table relates the DETECTOR ROTATION AXIS to the OSSE Y-AXIS. Numbers with parenthesis are those forecast per SER EX056-017. The numbers without parenthesis are those actually measured. All values in arc minutes.

Alignment Item	Uncertainty (3 sigma)		Error (3 sigma)	
	Scan	Cross-Scan	Scan	Cross-Scan
Detector Rotation Axis (10 translation measurements of .05, RSS'd)	-	(.16)	-	(1.35)

The effect of Detector Rotation Axis errors may add, or subtract, from the overall OSSE instrument pointing accuracy. The contribution depends on the detector position angle, and the sign of the error values with respect to instrument coordinate convention (Theta definitions). See Figures 2 and 5.

TABLE 3-19

ALIGNMENT ERROR BUDGET VS
ALIGNMENT ACHIEVED

This table relates the DETECTOR FIELD OF VIEW to the DETECTOR ROTATION AXIS. Numbers with parenthesis are forecast per SER EX056-017. Those numbers without parenthesis are measured or estimated on the basis of observation or calculation.

DETECTOR 3 (+X,-Y) Alignment Item	Uncertainty (3 sigma)		Error (3 sigma)	
	Scan	Cross-Scan	Scan	Cross-Scan
Collimator	(0.8) 1.60	(2.06) 0.97	0	4.0 *
Collimator/ Detector Cube	(0.67) 0.67	(0.67) 0.67		
Drive Backlash	(2.43) 2.22	- -		
Pot Zero/Nearest Step	(0.49) 0.49	- -		
Gravity Deform- ation	(0.20) 0.20	(0.20) 0.20		
Thermal Deform- ation	(0.11) 0.11	(0.11) 0.11		
Alignment Cube Fabrication (3 cubes)	(0.17) 0.17 (0.17) 0.17 (0.17) 0.17	(0.17) 0.17 (0.17) 0.17 (0.17) 0.17		
Alignment Cube Measurements (4 measurements)	(0.05) 0.05 (0.05) 0.05 (0.05) 0.05	(0.05) 0.05 (0.05) 0.05 (0.05) 0.05		
RSS Sum	(2.67) 2.88	(2.20) 1.24		

* No specification

TABLE 3-20

ALIGNMENT ERROR BUDGET VS
ALIGNMENT ACHIEVED:
DETECTOR ROTATION AXIS

This table relates the DETECTOR ROTATION AXIS to the OSSE Y-AXIS. Numbers with parenthesis are those forecast per SER EX056-017. The numbers without parenthesis are those actually measured. All values in arc minutes.

DETECTOR 3 (+X,-Y) Alignment Item	Uncertainty (3 sigma)		Error (3 sigma)	
	Scan	Cross-Scan	Scan	Cross-Scan
Detector Rotation Axis (10 translation measurements of .05, RSS'd)	-	(.16)		(2.13)

The effect of Detector Rotation Axis errors may add, or subtract, from the overall OSSE instrument pointing accuracy. The contribution depends on the detector position angle, and the sign of the error values with respect to instrument coordinate convention (Theta definitions). See Figures 3 and 5.

TABLE 3-21

ALIGNMENT ERROR BUDGET VS
ALIGNMENT ACHIEVED

This table relates the DETECTOR FIELD OF VIEW to the DETECTOR ROTATION AXIS. Numbers with parenthesis are forecast per SER EXO56-017. Those numbers without parenthesis are measured or estimated on the basis of observation or calculation.

DETECTOR 4 (+X,+Y) Alignment Item	Uncertainty (3 sigma)		Error (3 sigma)	
	Scan	Cross-Scan	Scan	Cross-Scan
Collimator	(0.8) 0.17	(2.06) 0.35	0	4.6 *
Collimator/ Detector Cube	(0.67) 0.67	(0.67) 0.67		
Drive Backlash	(2.43) 2.55	- -		
Pot Zero/Nearest Step	(0.49) 0.49	- -		
Gravity Deform- ation	(0.20) 0.20	(0.20) 0.20		
Thermal Deform- ation	(0.11) 0.11	(0.11) 0.11		
Alignment Cube Fabrication (3 cubes)	(0.17) 0.17 (0.17) 0.17	(0.17) 0.17 (0.17) 0.17		
Alignment Cube Measurements (4 measurements)	(0.05) 0.05 (0.05) 0.05 (0.05) 0.05	(0.05) 0.05 (0.05) 0.05 (0.05) 0.05		
RSS Sum	(2.67) 2.71	(2.20) 0.85		

* No specification

TABLE 3-22

ALIGNMENT ERROR BUDGET VS
ALIGNMENT ACHIEVED:
DETECTOR ROTATION AXIS

This table relates the DETECTOR ROTATION AXIS to the OSSE Y-AXIS. Numbers with parenthesis are those forecast per SER EX056-017. The numbers without parenthesis are those actually measured. All values in arc minutes.

DETECTOR 4 (-X,+Y) Alignment Item -----	Uncertainty (3 sigma)		Error (3 sigma)	
	Scan -----	Cross-Scan -----	Scan -----	Cross-Scan -----
Detector Rotation Axis (10 trans- lation measurements of .05, RSS'd)	-	(.16)	-	(2.53)

The effect of Detector Rotation Axis errors may add, or subtract, from the overall OSSE instrument pointing accuracy. The contribution depends on the detector position angle, and the sign of the error values with respect to instrument coordinate convention (Theta definitions). See Figures 4 and 5.

THE FOLLOWING FIGURES (3-9 through 3-12) SHOW THE FOLLOWING ALIGNMENT ERRORS FOR EACH DETECTOR (A1 THROUGH A4):

- 1 - Tilt of collimator out of perpendicularity with detector rotation axis.
In the OSSE coordinate system, this angle changes at different scan angles.
- 2 - Misalignment of FOV long axis with respect to scan axis.
- 3 and 4 - Misalignment of detector rotation axis (theta-X and Theta-Y) with respect to OSSE Y-axis.

FIGURE 3-9: DETECTOR A1 ALIGNMENT ERRORS

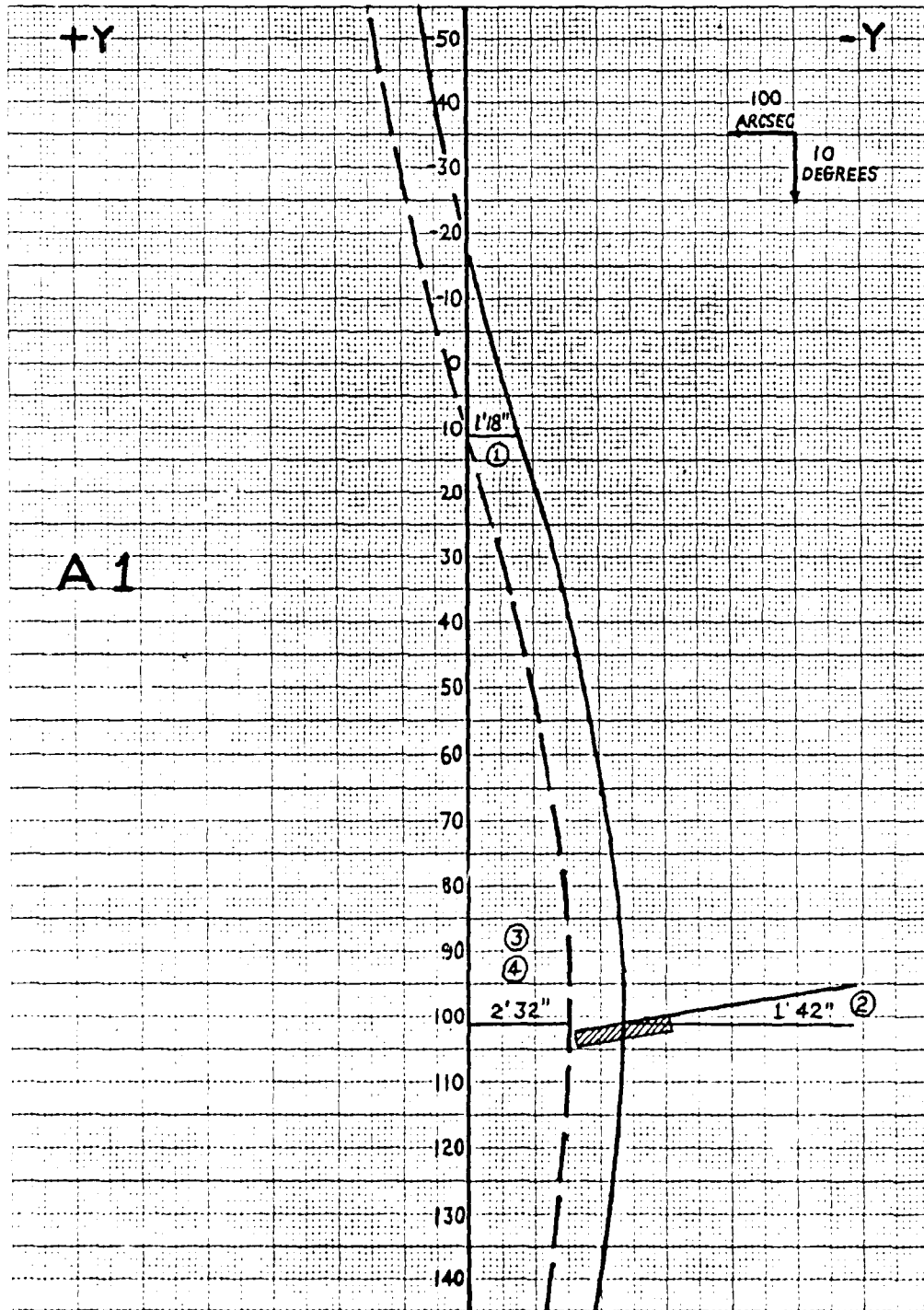

FIGURE 3-10: DETECTOR A2 ALIGNMENT ERRORS

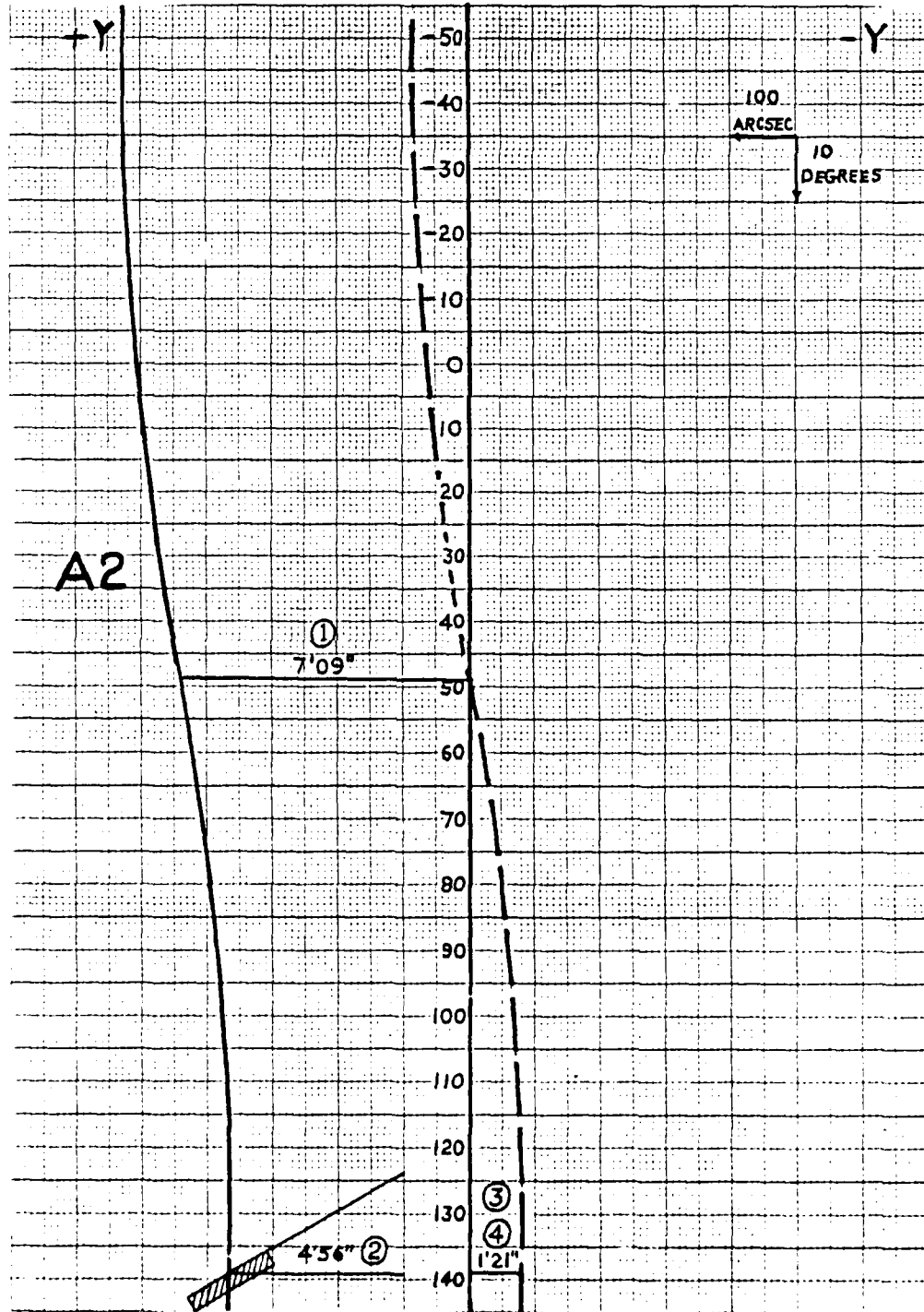

FIGURE 3-11: DETECTOR A3 ALIGNMENT ERRORS

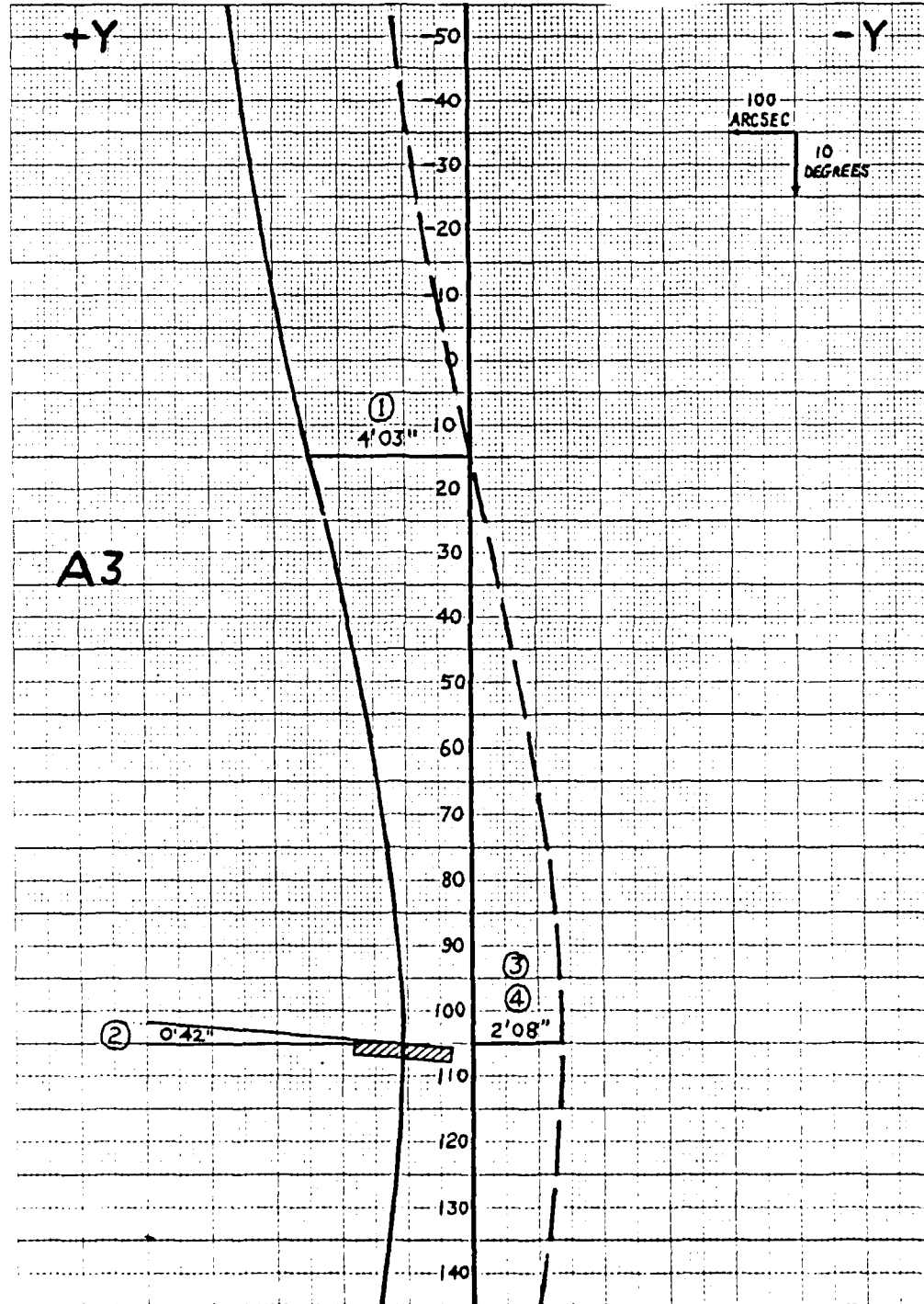
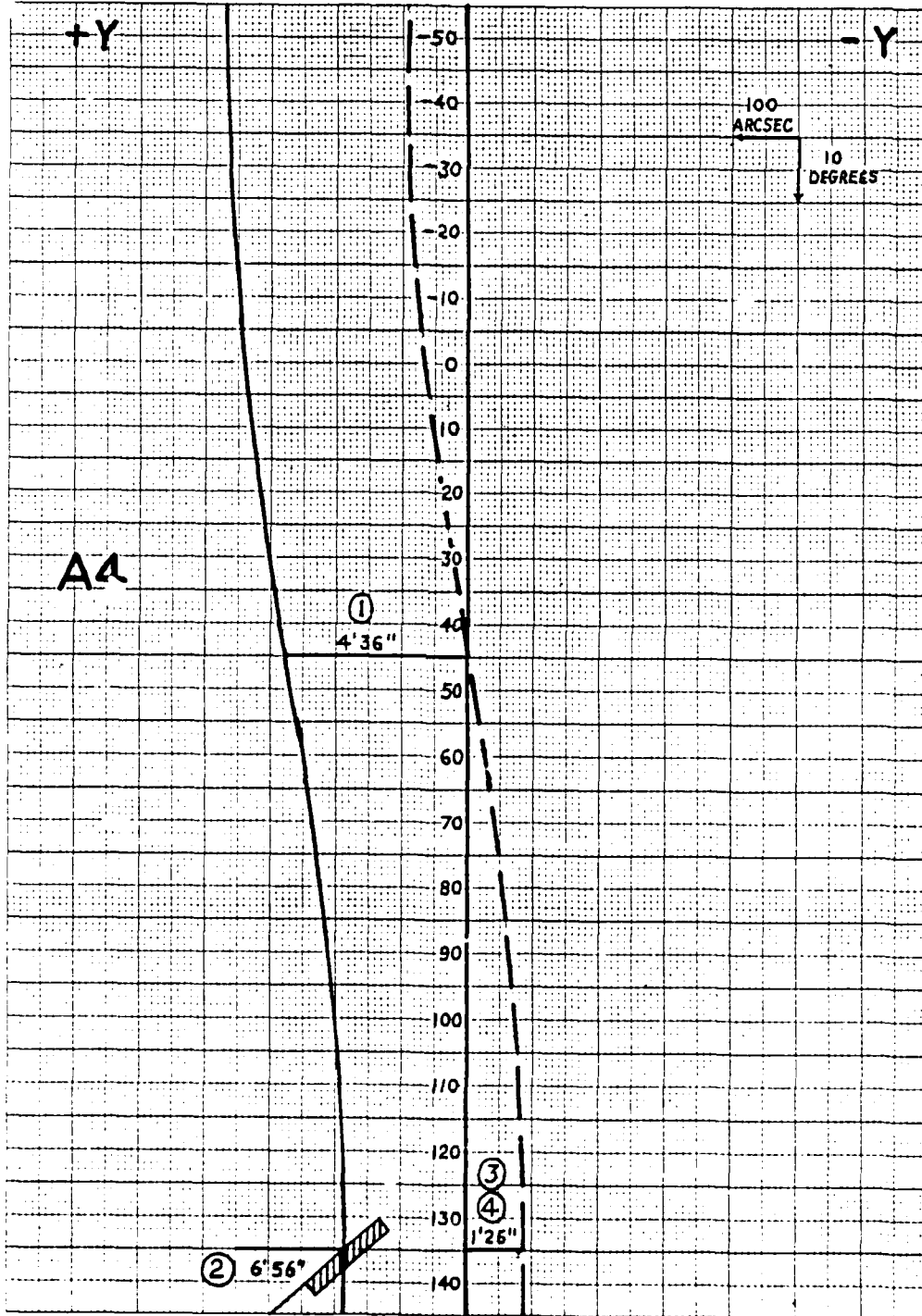

FIGURE 3-12: DETECTOR A4 ALIGNMENT ERRORS



3.0 DETECTOR FOV WITH RESPECT TO OSSE AXIS

3.1 Collimator Tilt With Respect To The Detector Rotation Axis

Result: Conical Scan

How Much: Detector 1: 1.3 arc minutes (cone in -Y hemisphere)
 Detector 2: 7.15 arc minutes (cone in +Y hemisphere)
 Detector 3: 4.0 arc minutes (cone in +Y hemisphere)
 Detector 4: 4.6 arc minutes (cone in +Y hemisphere)
 Requirement: None

Causes: a. Collimator orthogonality errors, systematic.
 b. Detector housing machining tolerances.
 c. Potential, though small, for distortion of the detector housings resulting from pre-loads of the shield and phoswich crystals.
 d. No adjustment capability for placement of the collimator in the detector housings.

In figures 3-9 through 3-12, the conical skews are shown as the distances between the solid line sweep of the measured collimator FOV and the dotted line sweep of a 'perfect' collimator with respect to the axis of rotation.

3.2 Long/Short Axis Not Orthogonal To Scan Axis, Instrument Axis, Or Both.

Result: May reduce area overlapped with other detectors at the same scan angle.

How much: Detector 1: -2.2 arcmin (collimator rotated CW viewed from +Z)
 Detector 2: -4.93 arcmin CW
 Detector 3: 0.7 arcmin CCW
 Detector 4: -6.93 arcmin CW
 Requirement: None

Causes: Detector housing and collimator machining tolerances. For example, one arc minute of collimator rotation about the Z-axis is equivalent to only .002" at the detector/collimator interface radius.

In figures 3-9 through 3-12, the exaggerated rotation of the rectangular box about the scan plane represents this condition.

4.0 DETECTOR ROTATION AXES WITH RESPECT TO OSSE AXES

4.1 Detector Axis Not Coinciding With OSSE Y Axis, Rotated About X-Axis

How Much: Detector 1: -0.60 arcmin (these values are Theta X errors)
 Detector 2: -1.00 arcmin
 Detector 3: -0.43 arcmin
 Detector 4: -1.01 arcmin

4.2 Detector Axis Not Coinciding With OSSE Y Axis, Rotated About Z-Axis

How Much: Detector 1: -2.46 arcmin (these values are Theta Z errors)
Detector 2: -0.83 arcmin
Detector 3: -2.08 arcmin
Detector 4: -1.02 arcmin

4.3 Combined Detector Axis Misalignment

Detector 1: 2.53 arcmin
Detector 2: 1.35 arcmin
Detector 3: 2.13 arcmin
Detector 4: 1.43 arcmin
Requirement: 3.00 arcmin

Result of 5.1 and 5.2: The detector oscillates sinusoidally about the Instrument Y-axis.

Causes: Assembly tolerances, variation of instrument mounting surface, placement and removal of thermal isolation blocks, etc.

In figures 3-9 through 3-12, the broken solid line represents the plane perpendicular to the detector rotation axis.

THE FOLLOWING FIGURES SHOW DETECTOR MISALIGNMENTS IN THE Y-Z PLANE (FIG 3-13) AND THE X-Z PLANE (FIG 3-14):

FIGURE 3-13: Y-Z PLANE MISALIGNMENTS

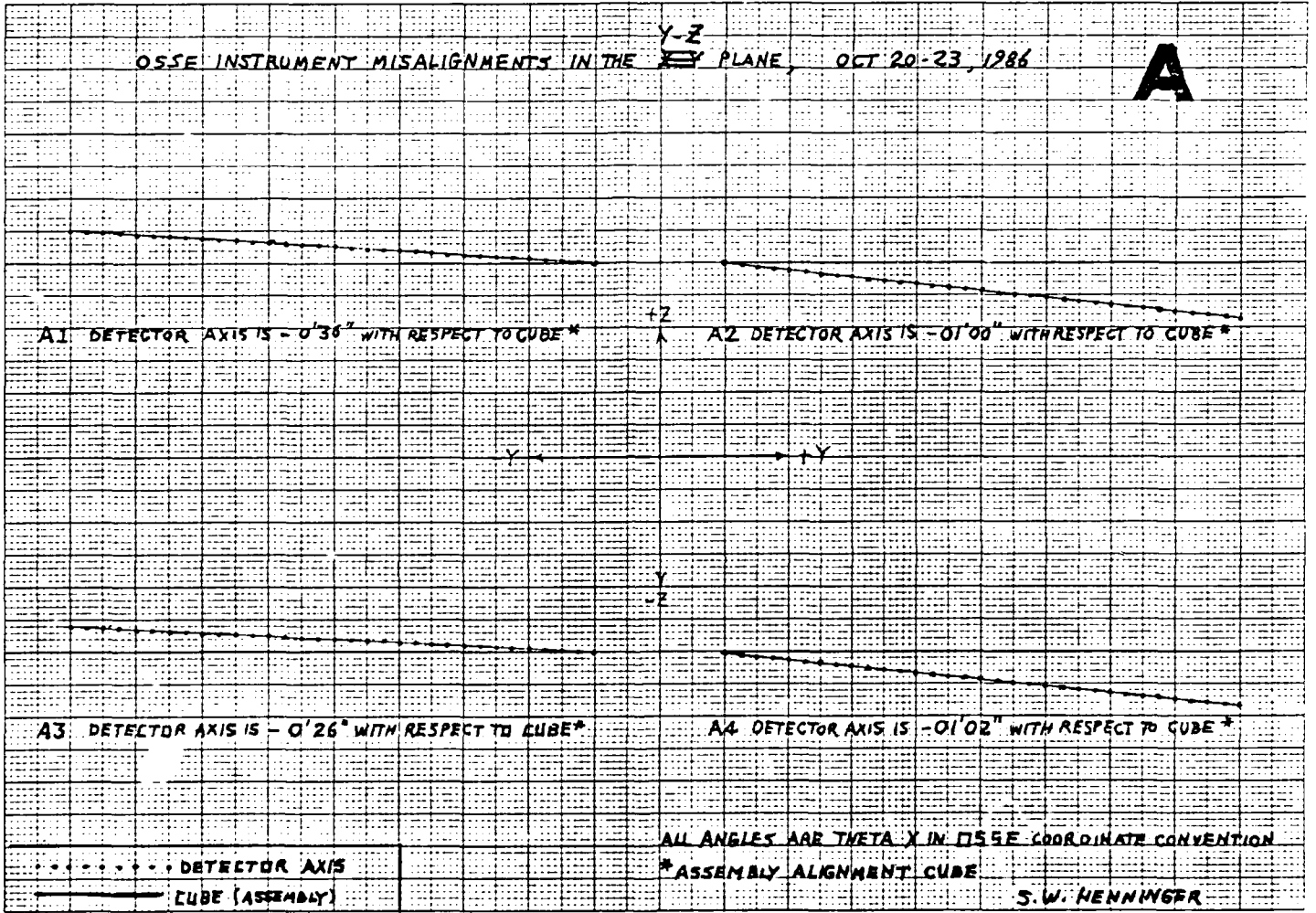
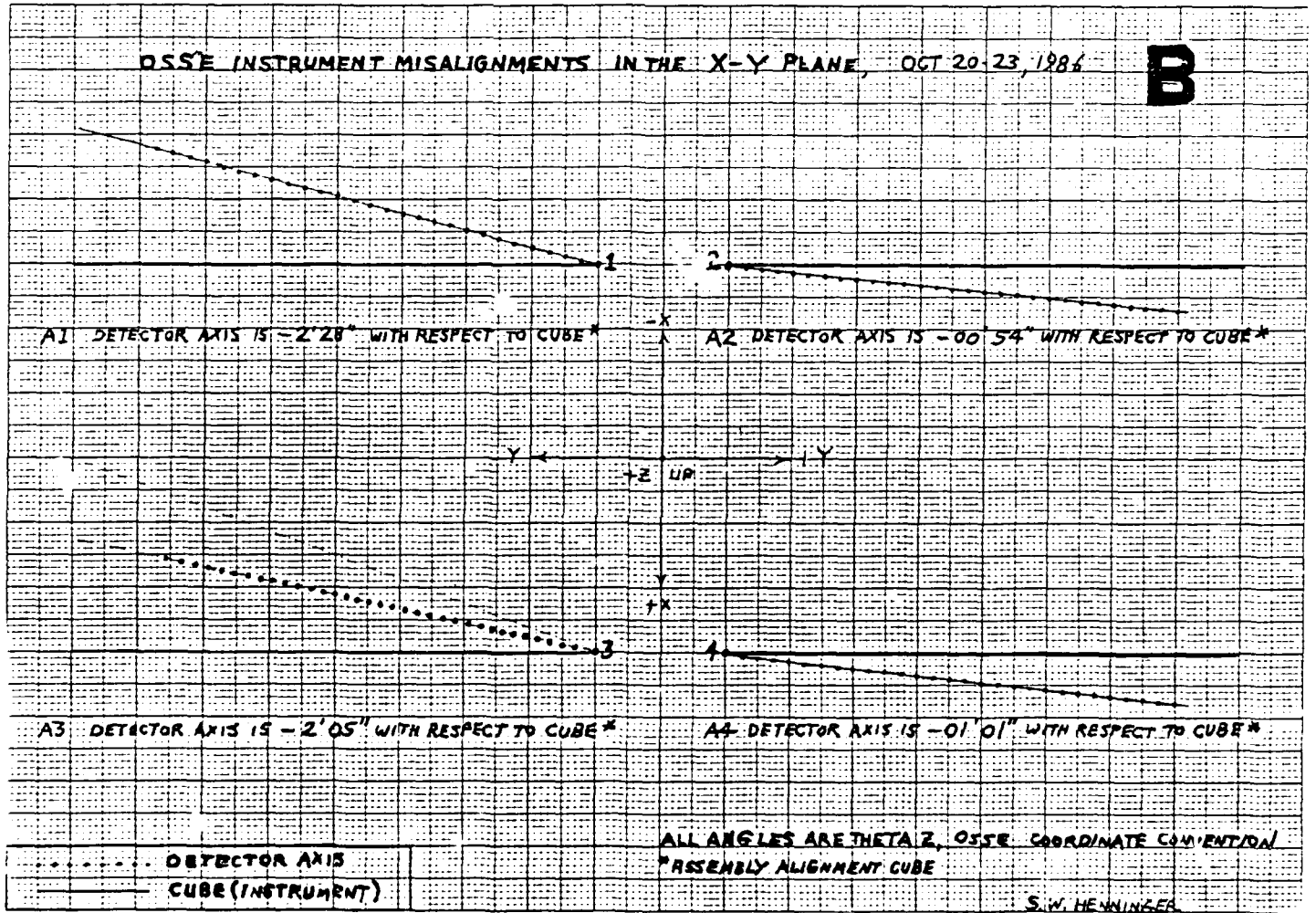

FIGURE 3-14: X-Z PLANE MISALIGNMENTS



4.4 Compliance Of Results To Requirements (1.0 ALIGNMENT OBJECTIVE):

- a) The center of the FOV shall be known to ≤ 6.0 arc minutes (3.0 arc minutes allotted to internal OSSE uncertainty of detector FOV to the mounting surface in the X-Z (scan) plane), and known to ≤ 8.0 arc minutes in the cross-scan plane (with 5.0 arc minutes allotted to internal OSSE alignment uncertainty of detector FOV to the mounting surface in the X-Z (scan) plane).

Detector 1:	Scan 2.66 arcmin	(should be < 3.0 arcmin).	YES
	Cross-scan 1.64 arcmin	(should be < 5.0 arcmin).	YES
Detector 2:	Scan 2.22 arcmin	(should be < 3.0 arcmin).	YES
	Cross-scan 0.64 arcmin	(should be < 5.0 arcmin).	YES
Detector 3:	Scan 2.88 arcmin	(should be < 3.0 arcmin).	YES
	Cross-scan 1.24 arcmin	(should be < 5.0 arcmin).	YES
Detector 4:	Scan 2.71 arcmin	(should be < 3.0 arcmin).	YES
	Cross-scan 0.85 arcmin	(should be < 5.0 arcmin).	YES

- b) The center of the detector FOV relative to the crystal housing must have an uncertainty ≤ 1.0 arc minute in the X-Z (scan) direction and three arc minutes in the perpendicular (cross-scan) direction.

Detector 1:	Scan 0.89 arcmin	(should be < 1.0 arcmin).	YES
	Cross-scan 1.60 arcmin	(should be < 3.0 arcmin).	YES
Detector 2:	Scan 0.75 arcmin	(should be < 1.0 arcmin).	YES
	Cross-scan 0.74 arcmin	(should be < 3.0 arcmin).	YES
Detector 3:	Scan 1.73 arcmin	(should be < 1.0 arcmin).	NO *
	Cross-scan 1.17 arcmin	(should be < 3.0 arcmin).	YES
Detector 4:	Scan 0.69 arcmin	(should be < 1.0 arcmin).	YES
	Cross-scan 0.76 arcmin	(should be < 3.0 arcmin).	YES

- * The collimator for this detector was measured per DD150689 on 6/24/85, one of the first fabricated (originally designated the engineering model) and the first measured. It is possible that the early measurements had larger uncertainties due to early production methods, or due to early measuring methods resulting in greater measured variances.

- c) Each detector subsystem must be positioned in the structure so that its rotation axis ≤ 3.0 arc minutes of the OSSE Y axis defined by the optical reference cube (known to ≤ 1.0 arcminute)

Detector 1:	2.53 arc min	(uncertainty 0.5 arc min)	YES
Detector 2:	1.35 arc min	"	YES
Detector 3:	2.13 arc min	"	YES
Detector 4:	1.43 arc min	"	YES

5.0 POT LINEARITY AND STEP SIZE CALIBRATION

Test procedure 150704, Proof Mode Drive Calibration, section 6 and data sheets 2A and 2B measured step size and step uniformity for each of the four detector motor drives. The absence of a braking pulse at the time of measurement just prior to hardware/software integration (DD156416) resulted in variations of individual step sizes from one step to the next, but the overall linearity of the pots, and the average step lengths (3.333 arc min) was verified optically during these tests and confirmed later in SYSPOTLIN

ATP's associated with baseline and subsequent functionals. Individual step size was verified in SYSPOTLIN ATP's run during subsequent functionals. Once the long braking pulse was functional, step size was consistent for all drives.

SEE FIG RES 3-15 through 3-25. They illustrate pot value linearity with respect to measured angle for each drive system.

FIGURE 3-15 POT VS ANGLE
DETECTOR A1

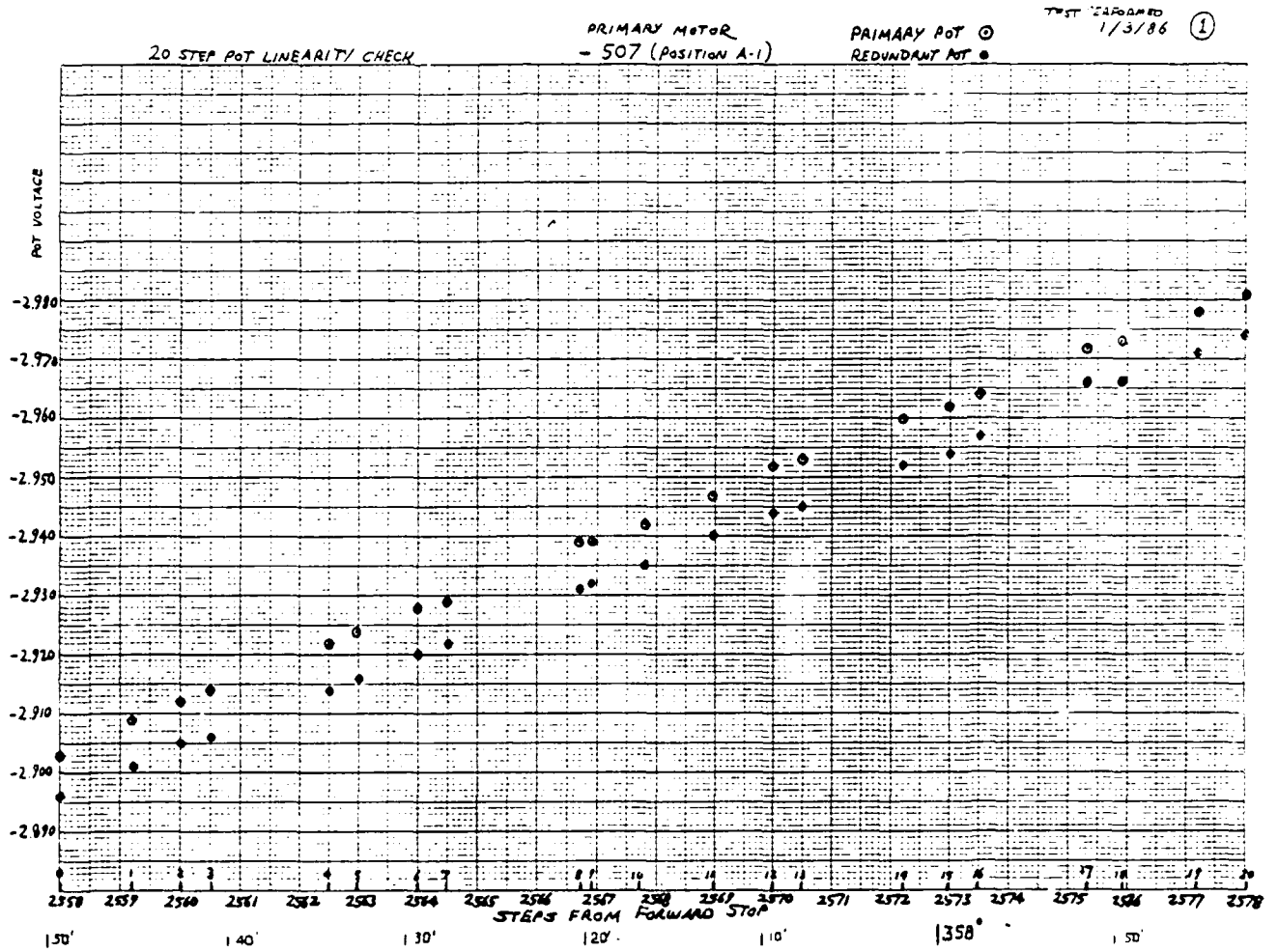

FIGURE 3-16 POT VS ANGLE
DETECTOR A1

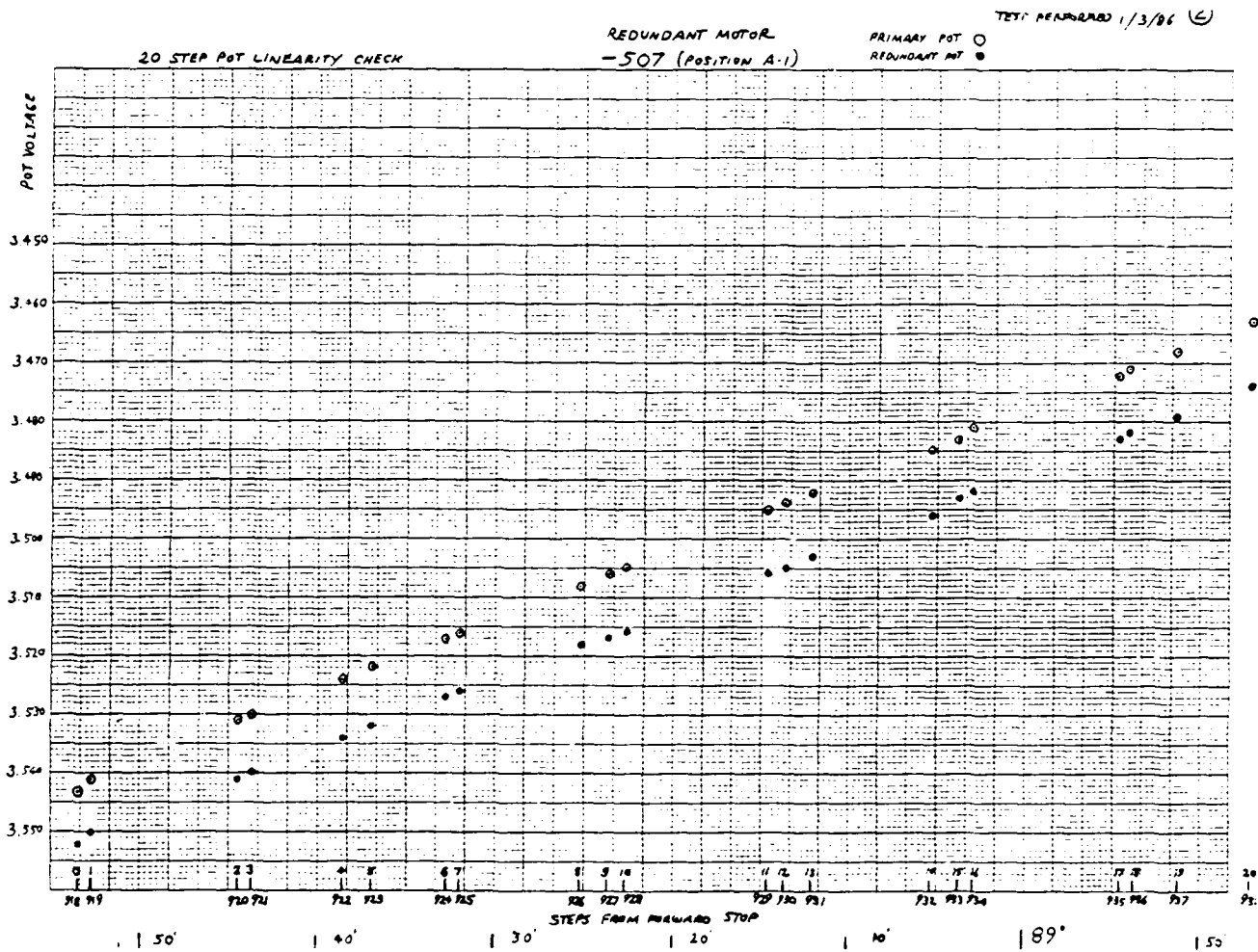

FIGURE 3-17 POT VS ANGLE
DETECTOR A1

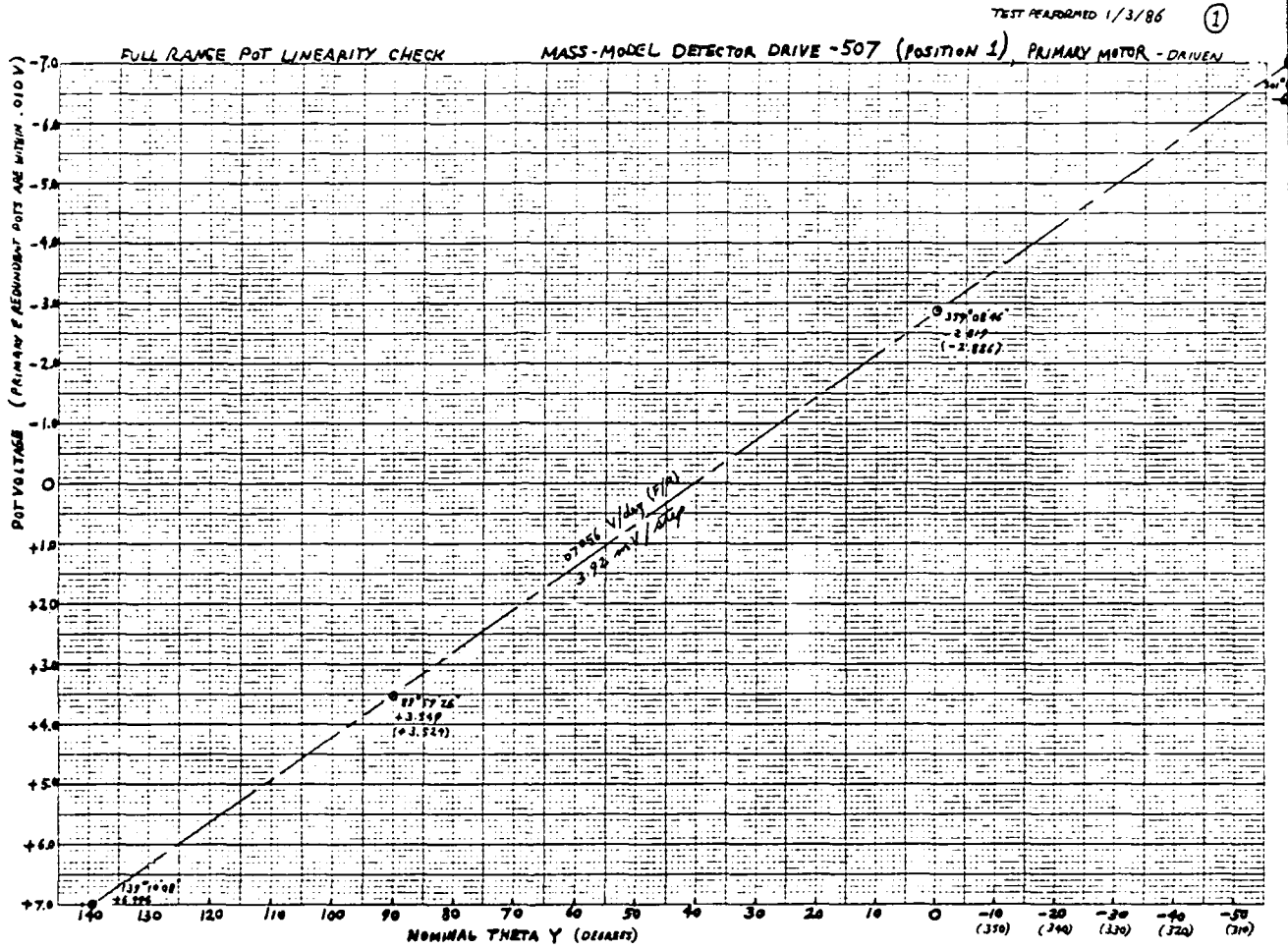

FIGURE 3-18 POT VS ANGLE
DETECTOR A2

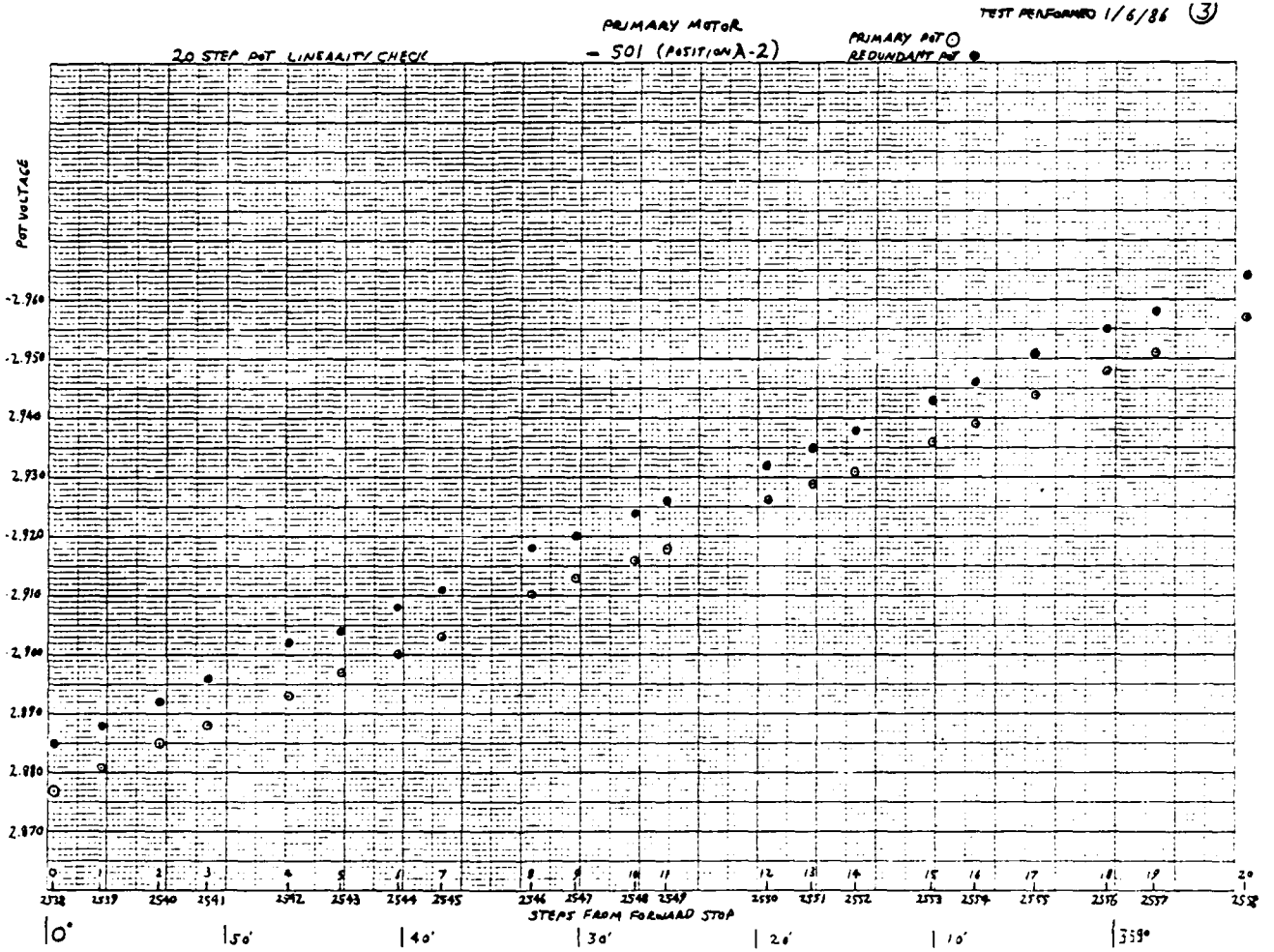

FIGURE 3-19 POT VS ANGLE
DETECTOR A2

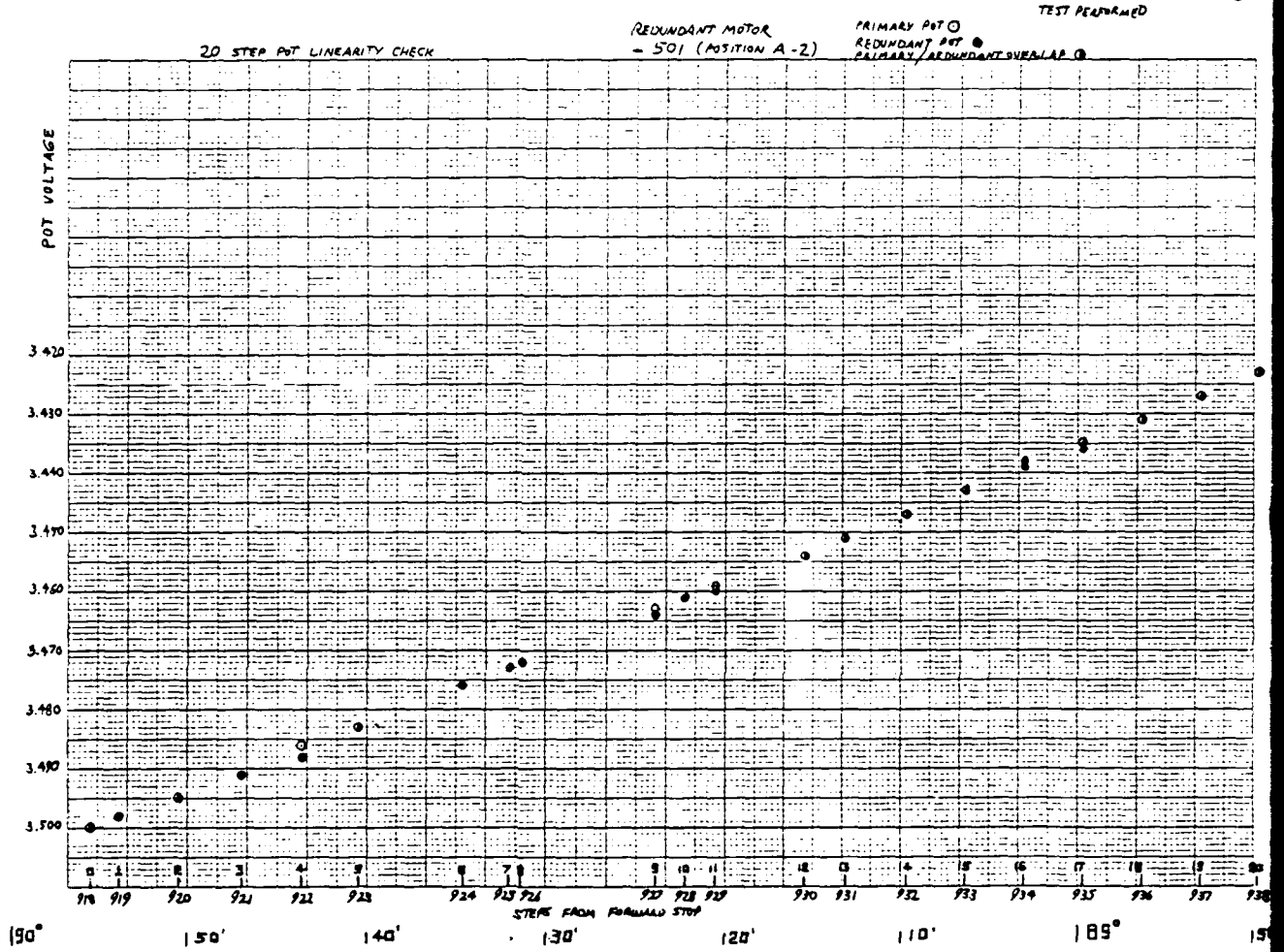

FIGURE 3-20 POT VS ANGLE
DETECTOR A2

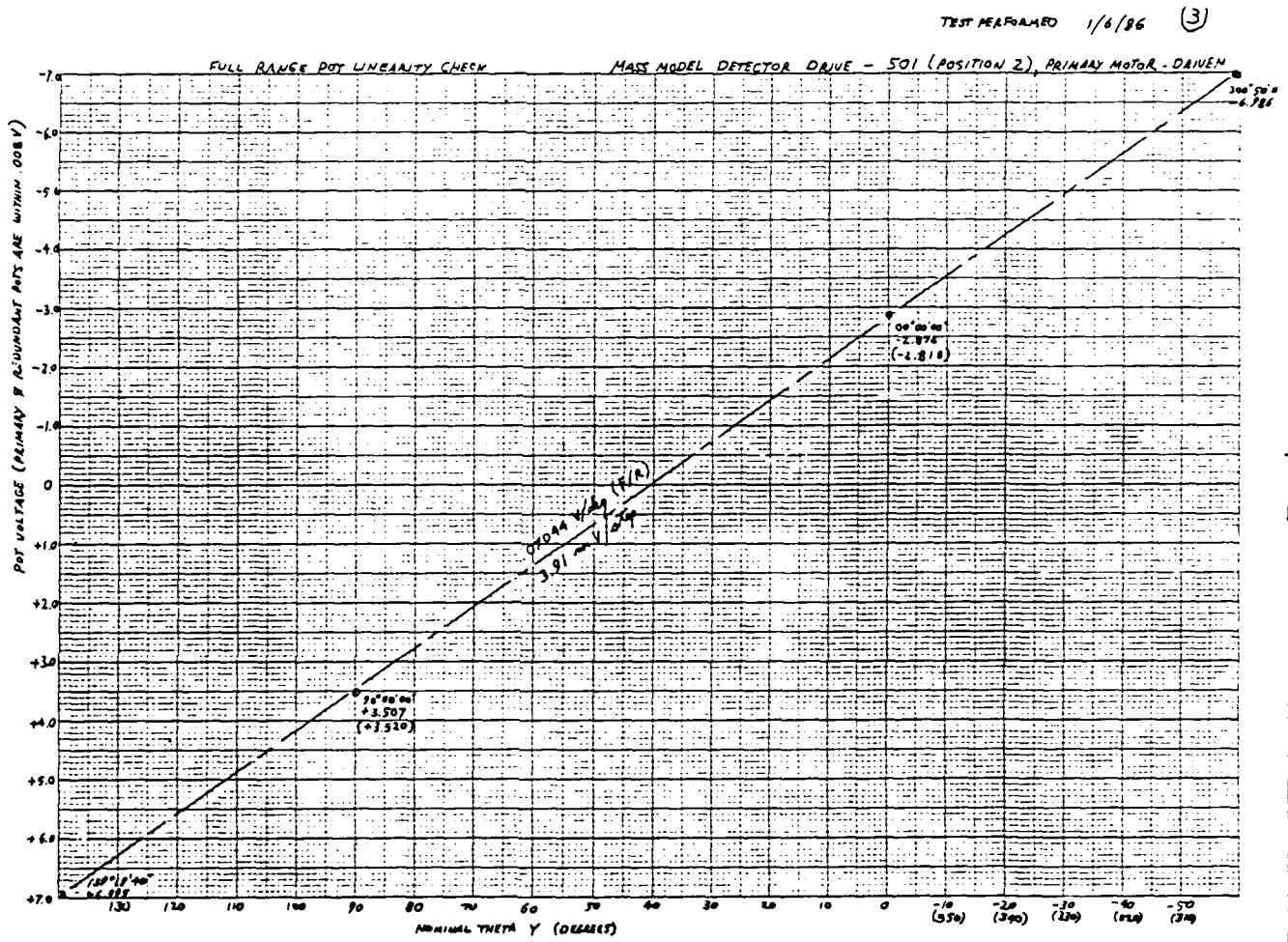

FIGURE 3-21 POT VS ANGLE
DETECTOR A3

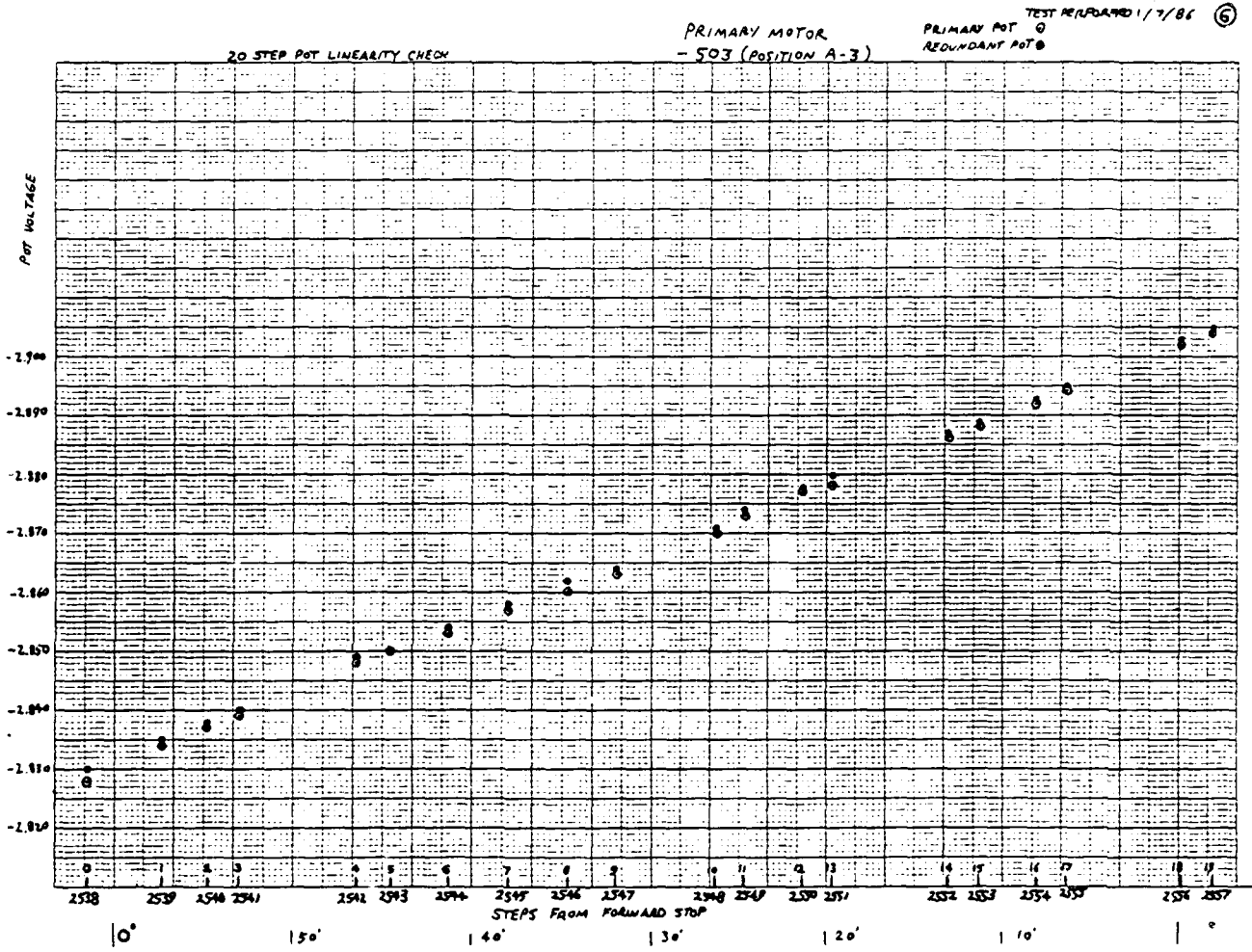

FIGURE 3-22 POT VS ANGLE
DETECTOR A3

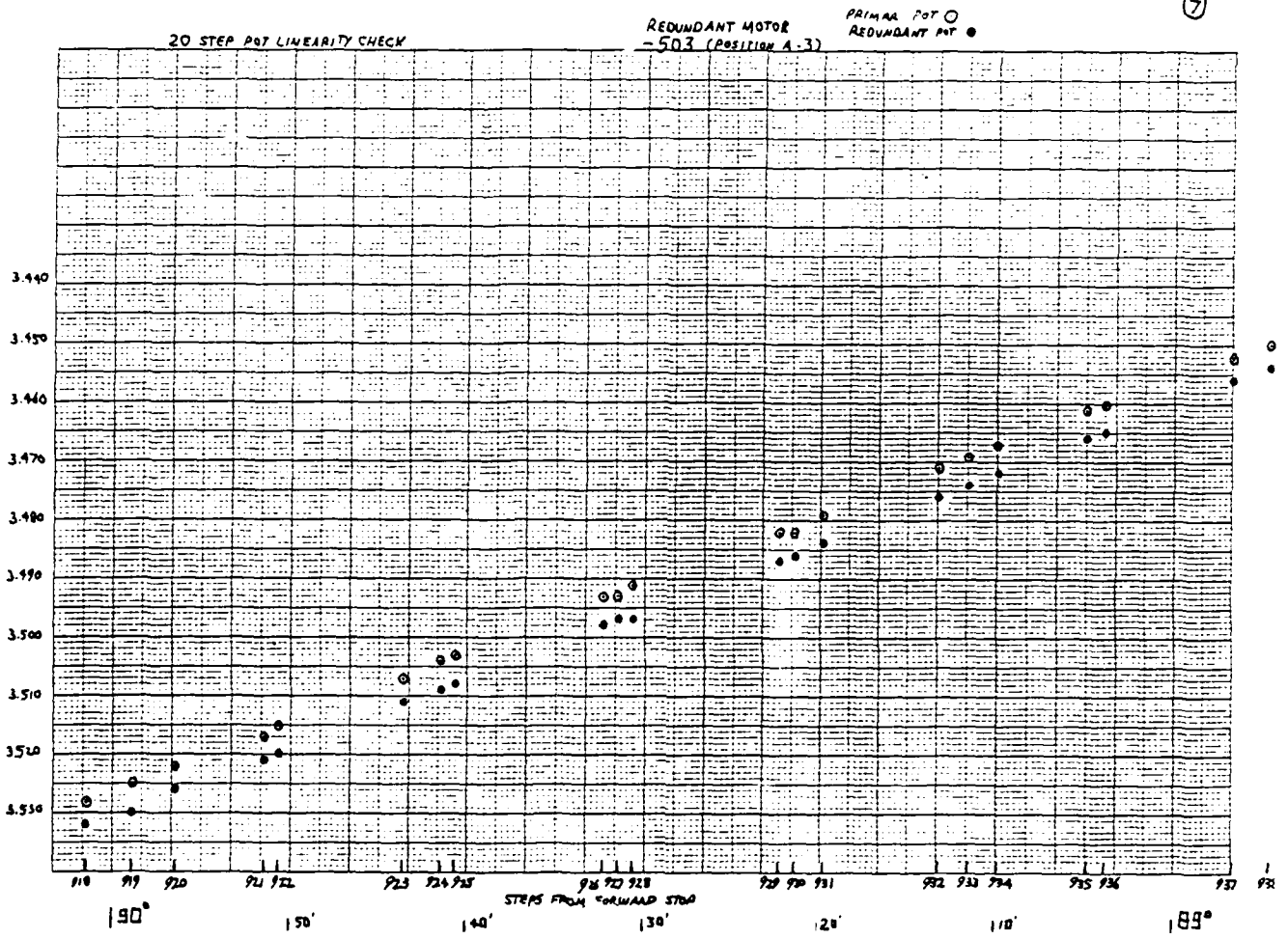

FIGURE 3-23 POT VS ANGLE
DETECTOR A3

TEST PERFORMED 1/7/86 (6)

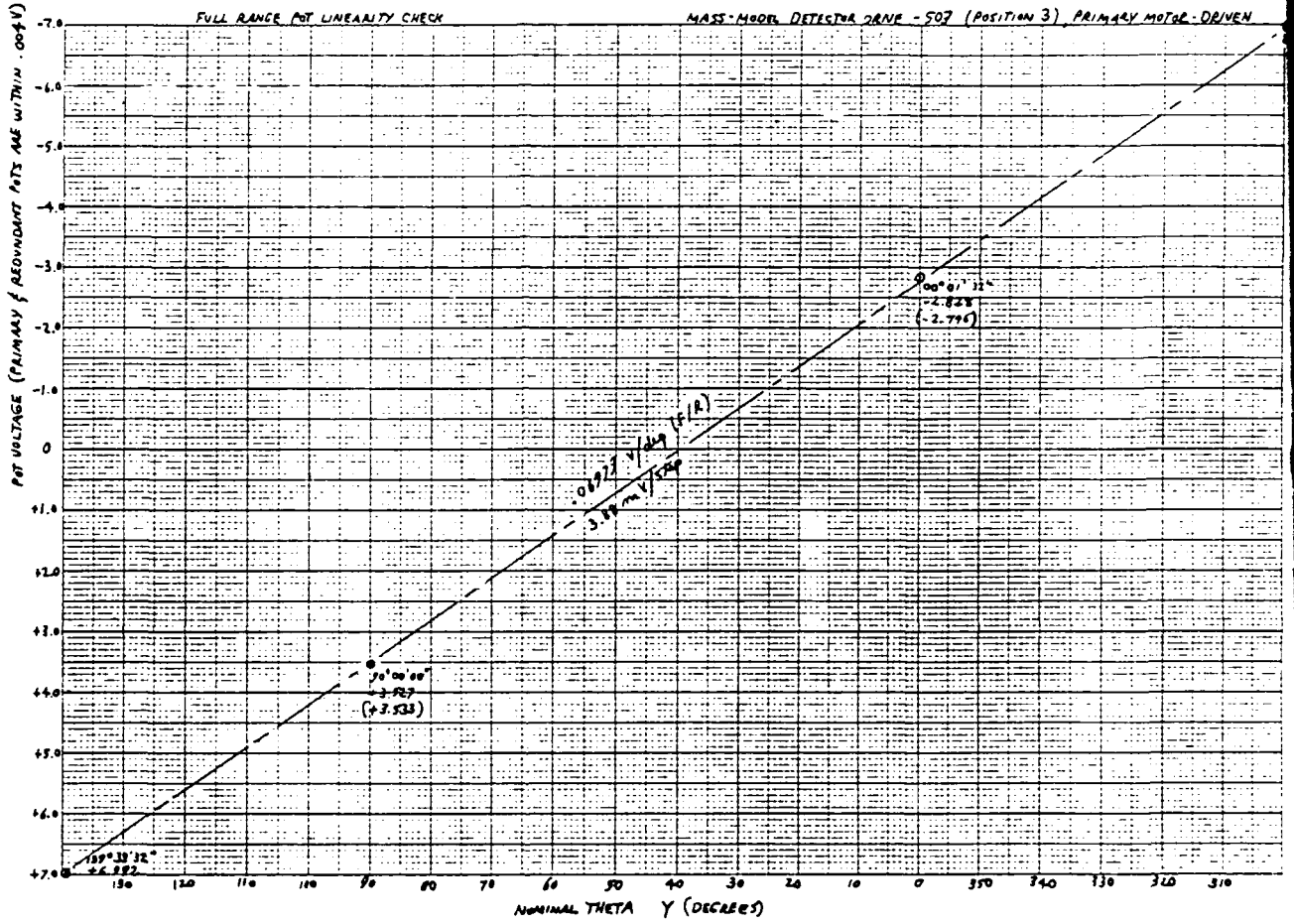

FIGURE 3-24 POT VS ANGLE
DETECTOR A4

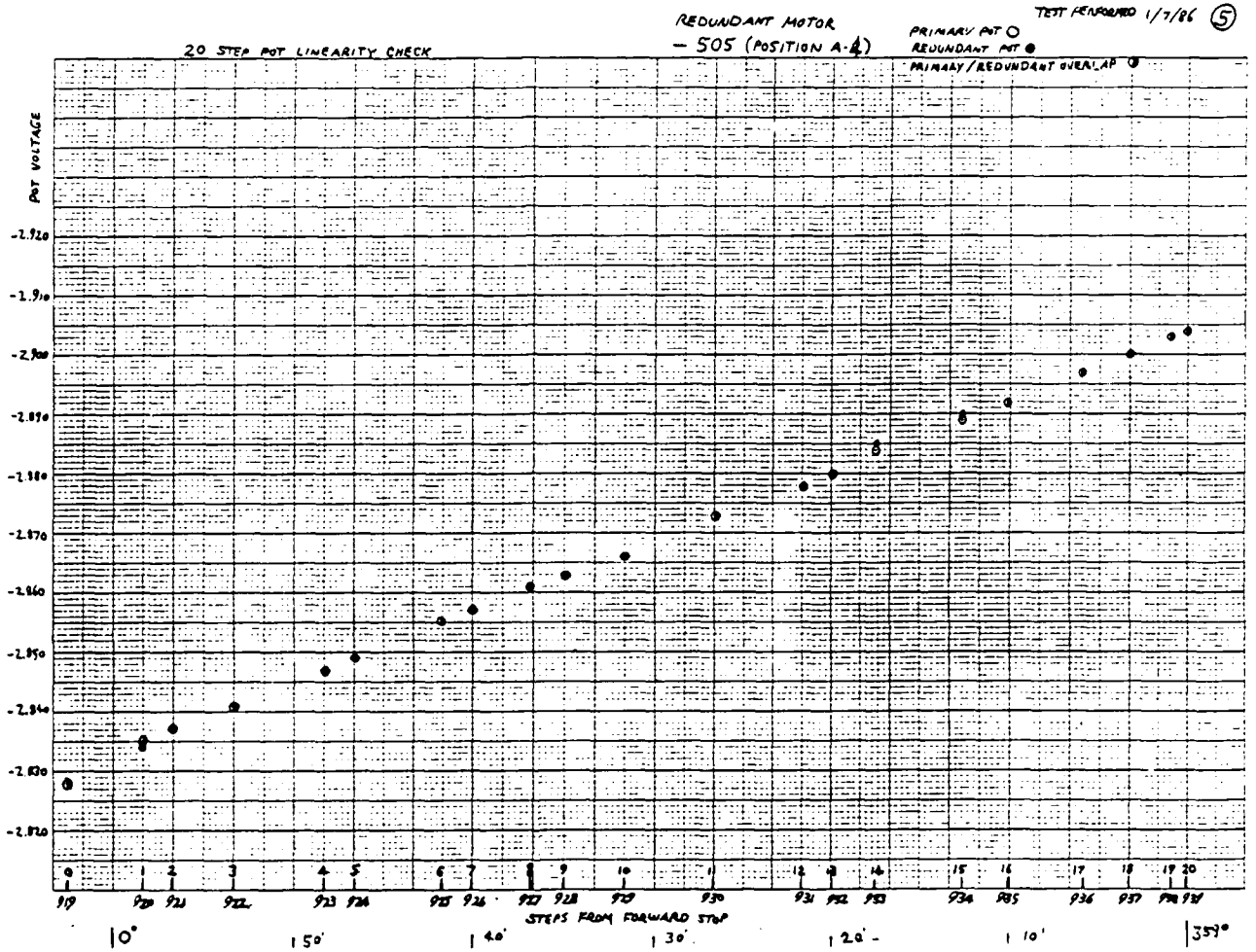
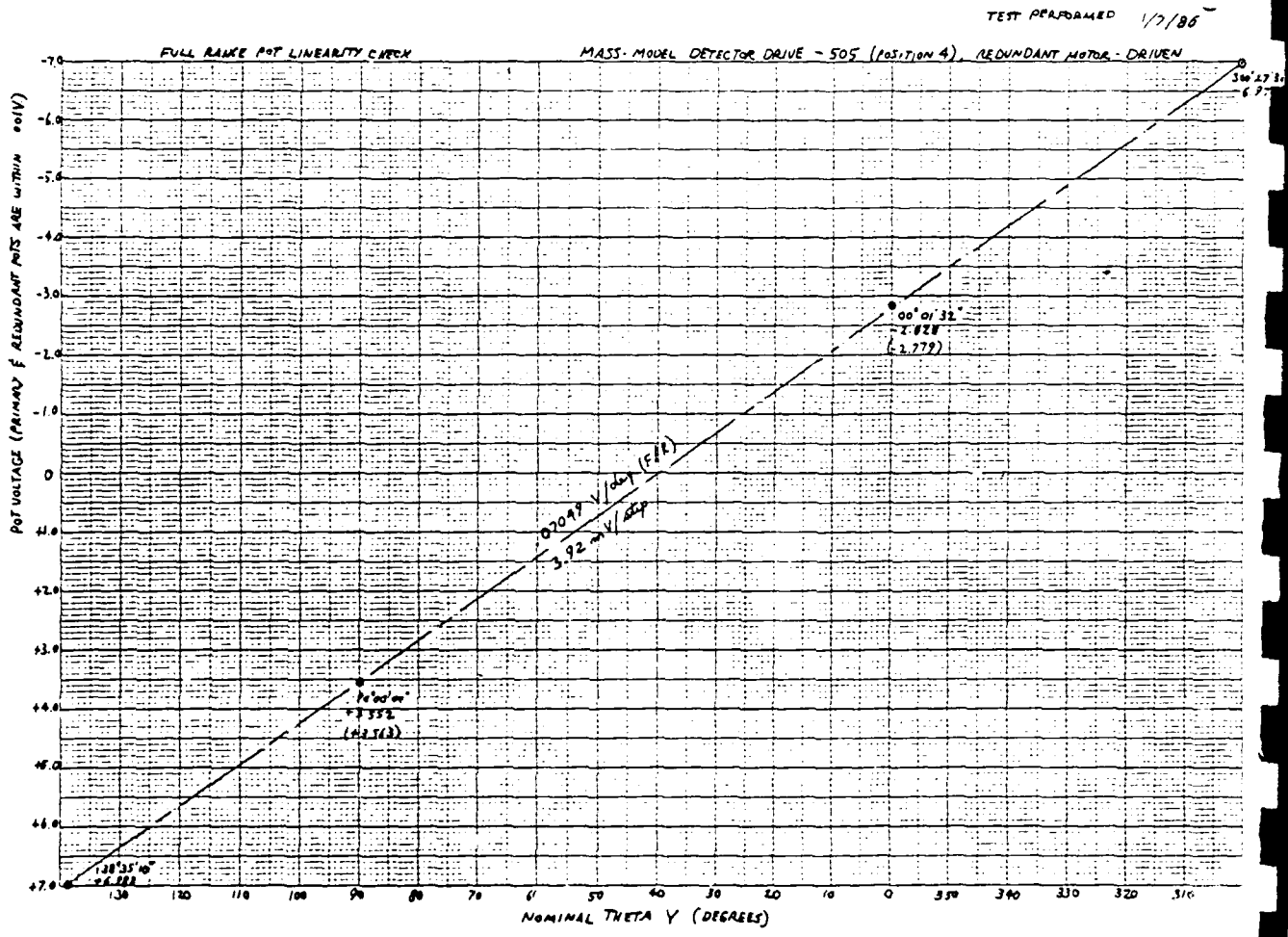

FIGURE 3-25 POT VS ANGLE
DETECTOR A4



5.0 AIMS STRUCTURE SURVEYS

The OSSE Instrument was surveyed on the following occasions, using targets affixed to various points on the inboard and outboard members of the structure:

Date	Structure Config	Occasion	Mount Results
04/ /85	No Load	Pre-Modal, Static	Pit *
07/29/85	Mass-Model Load	Pre-Modal, Static,	Pit
08/06/85	Static Load Test, Three Days	Static Load Test #7	Pit
09/26/85	Mass-Model Load	Post-Modal, Static,	Pit
10/02/85	No Load	Post-Modal, Static	Pit
11/14/85	No Load	Transition to Dolly	Dolly *
11/21/85	Motor Drives Only	Mounting of Motor Drives	Dolly
11/22/85	Motor Drives and Mounting Hardware	Before Mounting Mass Models	Dolly **
11/25/85	Mass-Model Load	After Mounting Mass Models	Dolly ** ***
10/15/86	Complete Instru- ment, Flight Hardware, On Ther- mal Iso-Blocks	Complete Instrument Configuration On Thermal Isolation Blocks	Dolly
04/18/87	Complete Instru- ment, Flight Hardware, No Ther- mal Iso-Blocks	Complete Instrument Hard Down On Dolly Pads	Dolly ***

- * Surveys evaluated in SER EX056A 451. It said that the bare structure was not significantly bent, compressed, or stretched between April and November, 1985 - a period of much handling and structural testing.
- ** Surveys evaluated in SER EX056A 450. It said that the structure undergoes little deformation between an unloaded and a loaded state, and that detector axis rotations remain about the same. These results indicate a negligible alignment change will occur when OSSE is in zero-G in space, providing the instrument mounting interface remains stable.
- *** Surveys evaluated in Figure 11. Fewer targets were visible from the vantage points the two AIMS theodolites surveying the final configuration of OSSE on 04/18/87. The few targets that could be compared to the mass-model configuration of 11/25/85 indicated no

significant distortion of the structure, but several consistent changes appeared in the vectors between targets. These are:

- a. Vector between targets 10 and 14 $-.0085$ in.
- b. Vector between targets 5 and 10 $-.0105$ in.
- c. Vector between targets 8 and 10 $-.0108$ in.

An analysis was made to verify that the baseline targets located over the four +X footpads (targets 5, 8, 11, and 14 on Figure 11) had not changed significantly with respect to each other in the Y and Z component measurements. They correlated to within less than .002 inch. The conclusion drawn by these anomalies is that target 10 on the center structure was not accurately measured in the survey of 4/18/87 because it was partially obstructed with respect to one of the theodolites, and the measurement was degraded. Since the rotation axes measured in test procedure 150711 did not show a corresponding change. It is unlikely that a distortion of the center structure occurred.

- d. Vector between targets 7 and 14 $+0326$.

This change indicates a large movement of the upper outboard -Y structural member toward the -Y. This area of the structure is not rigidly constructed in the Y axis and account for the large movement. Since the float is in the direction of the Y-axis, no alignment change is expected for deflections of this magnitude.

Measurement uncertainties develop from the AIMS repeatability about .002", from the geometry of the setup (sighting angle, distance from target), and the peculiarities of different operators.

3.5 SYSTEM-LEVEL ENVIRONMENTAL TESTS

3.5.1 PROOF MODEL STRUCTURE TESTS

This report summarizes the procedures and results of performing tests on the completed OSSE structure, loaded with mass models prior to installation of, and substituting for, the detectors, Central Electronics (CE), and Charged Particle Monitor (CPM) flight subsystems. The detector drive and bearing flight subsystems were included as part of the OSSE proof model.

The purpose of these procedures was to certify the OSSE structure for flight, and the following tests were performed for this purpose: 1) Modal Survey per test procedure DD150707, 2) Static Load per test procedure DD150714, and 3) Proof Model Acoustic test per procedure DD150706.

3.5.1.1 PROOF MODEL MODAL SURVEY TEST

The OSSE Proof Model Modal Survey test was performed per test procedure DD150707 during the May-June, 1985 time period. A report on this test authored by David W. Paule, BASD/OSSE Senior Analyst, is excerpted here as a summary of this test, and begins here:

The full OSSE system is composed of a thermal shell, four gamma ray detector subsystems, a central electronics box, and the primary structure. The thermal shell, the detectors, and the central electronics box were qualified separately from the primary structure, and not included in this discussion.

The primary structure was modeled in NASTRAN, as shown in figure A. The detector subsystems were replaced by dummy masses, as well as the central electronics box and another, smaller (drive electronics) box. The dummy masses in reality were large bars of steel. The bearings and stub axels were real flight units. The flight gearboxes were included in the test to have the proper mass and because they were already installed.

The OSSE structure was mounted in the BASD Modal Survey Pit. To correct for minor irregularities in the pit floor, short aluminum blocks were used as spacers. They were stiff enough so that they had a negligible effect on the results.

A series of data files was generated from the final pre-test NASTRAN modes run. These files described the expected motion of each of the first eight modeshapes. The files were sent to the data acquisition computer at the Modal Survey Pit laboratory, to aid in the real-time evaluation of the testing.

The accelerometer locations, shown in Figure 3, had been picked earlier based on the expected mode-shapes and the known mass distribution. Note that the dummy detector masses had accelerometers located across the diameter from each other, to pick up any rotation present, and to avoid mixing rotation and translation responses.

The test sequence was to adjust the input level of the random vibration to the minimum necessary to get a good response. Generally this worked out to about 10 pounds of force. The number of data channels available led to running each input location twice, and moving the accelerometers and

reverifying the data acquisition setup.

The initial input location was the top center back of the center pedestal assembly. The initial results and input were limited to the Y direction, and that included the first two modes. Sufficient data was available to indicate that a better input location should be found. Several locations were tested by using an instrumented hammer to strike the structure and monitoring the accelerometer response from several locations around OSSE. The shaker was moved to node 517 as a result of this, and oriented to shake in the Y and subsequently the X direction.

The first, second, and fifth modes were found in this pass. The initially predicted modes and test modes and final NASTRAN modes are shown in Table 1.

The next input location was back at the top center, oriented in the X direction. The third and fourth modes were not sufficiently distinct from each other using this location, but the sixth and seventh modes were obtained.

The use of the instrument hammer led to fixing the shaker to a large massive block of steel and hanging it from a crane so that a Z vibration could be input on the centerline between the two lower forward detector gearboxes. This brought out the fourth mode, and when the shaker was relocated to the center back of OSSE, we got the third. For these, the data was collected over a bandwidth only ten Hertz wide, for better definition. The final data needed was obtained by using the instrumented hammer to strike the dummy detectors in a tangential direction, to find the frequencies of rotation. These are shown in Table 2.

DESCRIPTION OF THE MODEL REVISION

The (NASTRAN) revision process was performed using a computer program called MODALA.FOR over a week and a half period, and composed of about a dozen iterations.

The OSSE instrument uses angular contact bearings to support the detectors, and the flight bearings were used on the modal survey test. They were modeled as spring elements, such that each of the six components at each of the eight bearing locations had a single spring element. Angular contact spring stiffnesses are a function, among other things, of the preload applied. The bearings had been analyzed earlier with the BASD proprietary program BRGSTR, and representative spring rates were used in the model. Since the bearing preload is subject to manufacturing tolerances, the preload, and hence the stiffness, varies somewhat from spring to spring. The strain energy output, and knowledge of the actual frequencies involved, greatly aided the spring rate revision.

The first revisions changed the spring stiffnesses of the springs which represented the rotational stiffnesses of the gearboxes and removed most of the moment flexibility which had been at the joints of some of the elements.

Succeeding revisions lowered the stiffnesses of the aft diagonal strut and the back plate. These are the two portions of the structure which most contribute to the lateral stiffness. The modulus of the forward diagonal plate was increased. The plates of the center structure are revited

together using standard extruded angles at the joints. These angles are not designed to dump axial load into the structure, because they have essentially no end fixity, and so an improvement in the model was to greatly reduce their effective area.

In the real structure, many of the bars end in a simple bathtub fitting. Typically, one to three bolts go through the plate end of the fitting to make the connection. There are no splice plates across the flanges or web of the bar (all the bars are C channels) to carry moment loads. As a result, most of the bars had been modeled as being pin ended at the bolted end. The bolts, of course, were assembled with a considerable preload.

At the very low loads induced during the modal survey test, it was found that the joints actually behaved as if they were capable of carrying moment. The load path was simply a result of the direct contact pressure between the end of the bar and the mating surface. The plate end flexibility, while it had to be accounted for, had not as great an effect as had been expected, due to the effective bar cross-section acting at the mating surface.

The NASTRAN model was made with most of these joints having a short section of bar at the joint. That is, most of the bar would be one continuous member, and it would end with a second short member. This is shown in figure A, at the lower edge of the side support assemblies, where short stubs are visible. The lower ends of these are the outer interface points, which were originally modeled with moment flexibility, and which had moment stiffness added, but the stiffness reduced compared to the bar stiffness in the surrounding structure.

It should be remembered that the preload of the bolts at the joints must be sufficient to at least maintain the fixity of the joint to the desired joint load, if this type of connection occurs.

Other changes included reducing all of the moduli of elasticity by about two percent and reducing the stiffness of the vertical members of the side support structure a little bit. A final change was to reduce the effective thickness of an area where the inboard detector trunnions mount to the side wall panels with a partial bolt ring.

These changes brought the frequencies of the first six modes of the NASTRAN model to within four percent of the test modes. The normalized cross orthogonality check is about twelve percent or less within that set of frequencies, except for the fourth mode, which is about twenty-one percent, as shown in Table 3.

CONCLUSIONS

The structural modeling effort needs to be planned from the beginning with an eye towards the changes that will be needed as a result of the modal survey test. Bars should have short end segments so that the effective fixity can be adjusted, and the manner that the joints are modeled should be scrutinized closely.

The use of the strain energy option is quite handy as an aid in moving around the structural model when deciding what to change and how.

A firm grasp of the real structure and how it is modeled is essential. Where possible, real weights rather than estimated weights should be in the model.

FIGURE 3-26 OSSE PROOF MODEL MODAL SURVEY

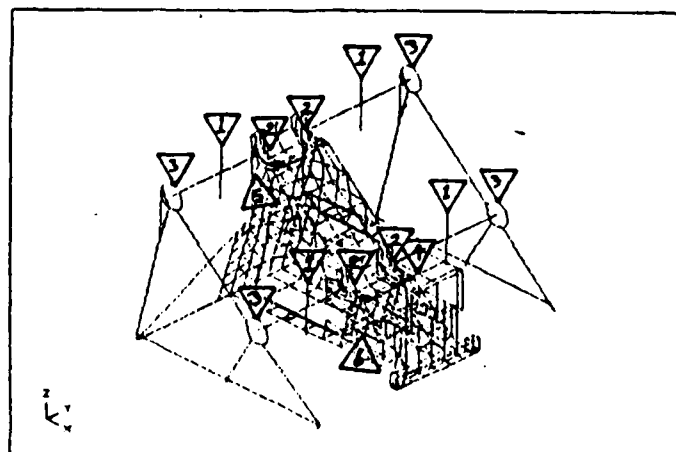
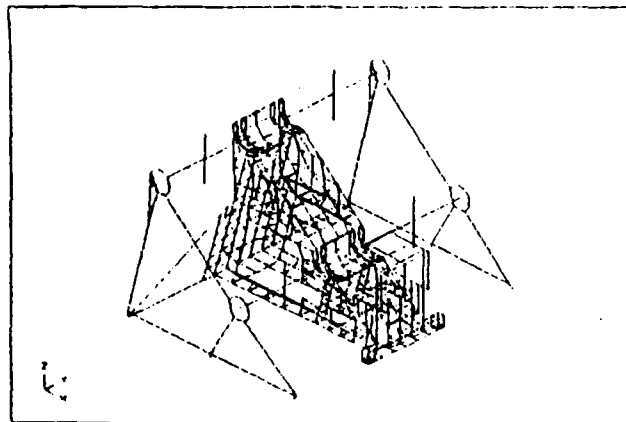
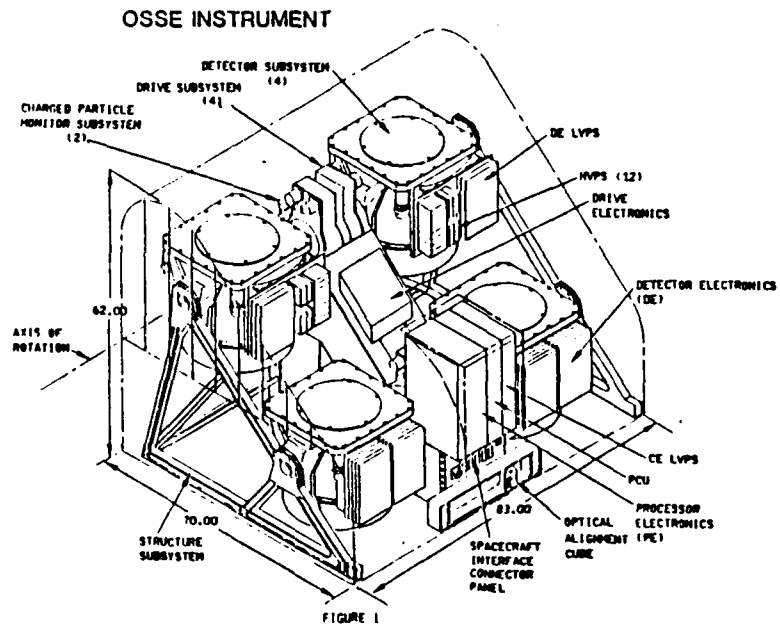

TABLE 3-23 OSSE PROOF MODEL MODAL SURVEY

TABLE 1

INITIAL NASTRAN PREDICTION	TEST RESULT	FINAL NASTRAN FREQUENCIES	SHAPE
27.4	26.98	27.43	CANTILEVER, $\pm Y$
34.3	38.54	37.69	2ND Y MODE
38.5	44.54	44.58	LWR DETECTOR MOTION PARALLEL TO SLANTED SURFACE
40.5	45.03	45.34	LWR DETECTOR MOTION PERPENDICULAR TO SLANTED SURFACE
53.5 (60.3, 62.9)	61.70	61.38	ROTATION ABOUT Z AXIS
65.1	77.89	75.08	X UPPER

TABLE 2

DUMMY DETECTOR ROTATIONAL FREQUENCIES

PREDICTED	TEST
11.5 hz	14.9
	12.2
	16.7
	14.0

TABLE 3

MODE	MODE FREQUENCY TEST	NORMALIZED CROSS ORTHOGONALITY CHECK, PERCENT	NASTRAN FREQUENCY COMPARISON, PERCENT
1	26.98	12.0	1.7
2	38.54	10.0	-2.2
3	44.54	4.3	0.1
4	45.03	21.1	0.7
5	61.70	9.3	-0.5
6	27.89	5.9	-3.6

3.5.1.2 PROOF MODEL STATIC LOAD TEST

The OSSE Proof Model Structure was static-load tested in accordance with the procedure described in DD150714. Originally, six separate static-load test configurations were planned. Two tests, #7 and #14, were actually run, both in August, 1985. The tests were done at the conclusion of the modal survey test described in 3.5.1.1, with the structure and the same flight (motor drives, detector bearings and axle stubs) and non-flight items (dummy masses for CE, Drive Electronics, and Detectors) in place. The site of these tests was the BASD modal survey pit, with the structure bolted to ten stiff aluminum blocks machined to compensate for the irregularities of the pit floor.

The structure was surveyed by the AIMS system, which measured the position of targets placed on the outboard and center structure members. This was done both before and after mounting the dummy masses, and data reduction determined that the movement of the rotation axes (depression of the structure) was $< .008''$ in the -Z direction, and negligibly in all other directions from Zero to One G. (Ref SER EX056A-450).

Strain gages (25 total) were installed on the structure, 18 single gages on the -Y outboard structure member, three Rosette gages on the center pedestal, two Rosettes on each side of the front support, and two axial strain gages, also on the front support. See FIGURE 3-27-1.

The two static load tests selected, #7 and #14 combined, demonstrated the strength of all portions of the OSSE structure. (See memorandum from Stephen J. Brodeur, Acting Head, Structural Loads and Analysis Section, GSFC). TABLE 3-24 (A and B) summarize the applied forces, and FIGURE 3-27-2 shows the typical setup, in this case, of Test #7.

For each of the two tests, the specified loads for the test were applied incrementally and simultaneously, then relaxed, so that an AIMS 'quick-look' of selected targets could verify the magnitude and nature of structural deformation under load, whether failures of any sort were developing, and whether the structure was returning to its original set upon relaxation. Strain gage data aided in this evaluation as well. Each time the forces were relaxed, a visual inspection of the structure was made for crack formation.

The successful completion of the static load certification tests for the OSSE structure, upon examination at the conclusion of the 100 percent application of the loads specified for tests # 7 and #14, was satisfied by 1) the absence of any cracks or other evidence of metal failure in any structural member or of any bolts, rivets, nuts, locking elements, etc, verified by visual inspection, 2) the absence of any significant permanent deformation of the structure, particularly that which might change detector axial rotation, verified by the AIMS surveys taken before, during, and after static load test series, and 3) the absence of any degradation of the mechanical performance, specifically, of the detector drive subsystems, verified by functional tests.

All three criteria were met upon completion of the static load test series. Refer to SER EX056-451, describing OSSE structural movements resulting from assembly, handling, and testing between April and November, 1985. The test data sheets from test procedure DD150714, strain gage readouts, and AIMS survey results have been retained for permanent record.

TABLE 3-24 OSSE PROOF MODEL STATIC LOAD TEST

OSSE STA - LOADS
TEST 7

CYLINDER I.D.	% of FULL LOAD								
	25%	50%	60%	70%	80%	90%	100%		
Cylinder #1 RHC-121 LOAD lbs	622 ^{±19}	1245 ^{±34}	1492	1740	1989 ^{±60}	2237	2486 ^{±75}		
POSITION "B" Cylinder #2 H-BEF-2 PRESSURE PSIG	175 ^{±41}	350 ^{±82}	420	490	560 ^{±152}	630	700 ^{±165}		
POSITION "C" Cylinder #3 B-17 LOAD lbs	400 ^{±24}	800 ^{±88}	960	1120	1280 ^{±141}	1440	1600 ^{±176}		
POSITION "E" Cylinder #4 H-5R PRESSURE PSIG	220 ^{±10}	440 ^{±41}	540	625	715 ^{±65}	805	895 ^{±81}		
POSITION "H" Cylinder #5 H-5R LOAD lbs	678 ^{±37}	1355 ^{±93}	1626	1897	2168 ^{±117}	2439	2710 ^{±147}		
POSITION "G" Cylinder #6 B-17 PRESSURE PSIG	410 ^{±60}	820 ^{±120}	980	1150	1310 ^{±192}	1470	1630 ^{±240}		
POSITION "I" Cylinder #7 H-5R LOAD lbs	1222 ^{±37}	2445 ^{±93}	2933	3422	3911 ^{±117}	4400	4889 ^{±147}		
	740 ^{±60}	1480 ^{±120}	1770	2060	2360 ^{±192}	2660	2950 ^{±240}		
	2001 ^{±60}	4003 ^{±120}	4803	5604	6404 ^{±192}	7205	8005 ^{±240}		
	305	610	730	850	970	1090	1210		

FIGURE 3-27-1 OSSE PROOF MODEL STATIC LOAD TEST

STRAIN GAGE LOCATIONS

① PUT THREE ROSETTE GAGES ON THE -Y SIDE PLATE OF THE CENTER PEDESTAL AS SHOWN:

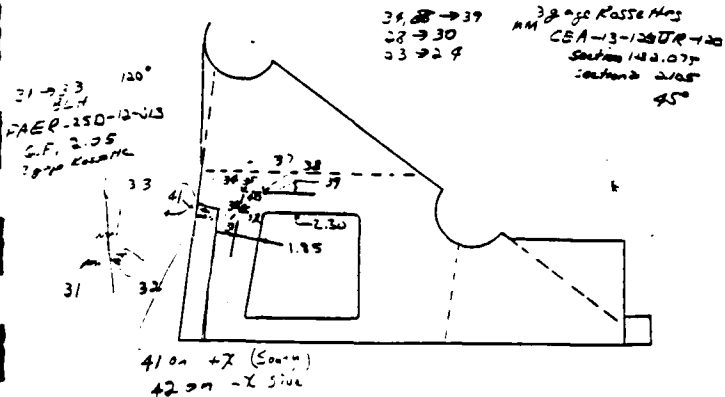

② INSTALL EIGHTEEN AXIAL STRAIN GAGES AS SHOWN BELOW:

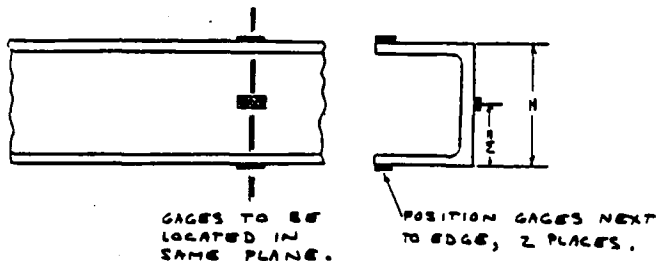

NOTE: ALL GAGES MUST BE LOCATED PARALLEL TO STRUT LONG AXIS.

ALSO, ALL GAGES MUST BE LOCATED SUCH THAT THE ONE CLOSEST TO A RADIUS IS LOCATED .50 INCHES FROM THE END OF THE RADIUS.

③ PUT ONE ROSETTE GAGE ON EACH SIDE OF THE FRONT SUPPORT AS SHOWN:

CENTER THE GAGE VERTICALLY ON THE FITTING.

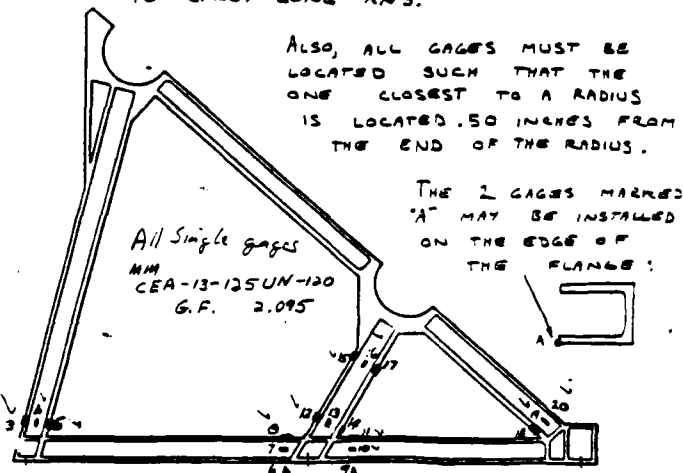
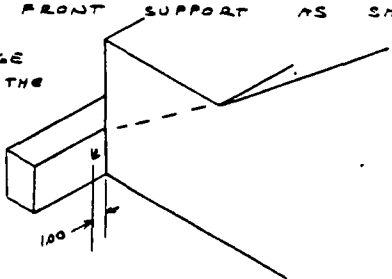

④ INSTALL TWO AXIAL STRAIN GAGES ON EACH SIDE OF THE FRONT FITTING IN THE SAME X-Z PLANE AS THE ROSETTE GAGES SHOWN IN ③.

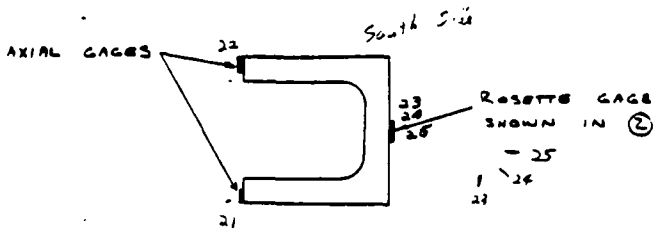

⑤ IN ALL CASES, THE BASE METAL IS ALUMINUM. FOR ITEMS ① AND ② THE MODULUS IS 9.9×10^6 PSI.

FOR ITEMS ③ AND ④ THE MODULUS IS 10.5×10^6 PSI.

⑥ = WOULD PREFER PSI AS OUTPUT RATHER THAN STRAIN.

Ver. 57

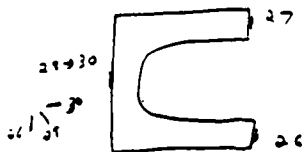
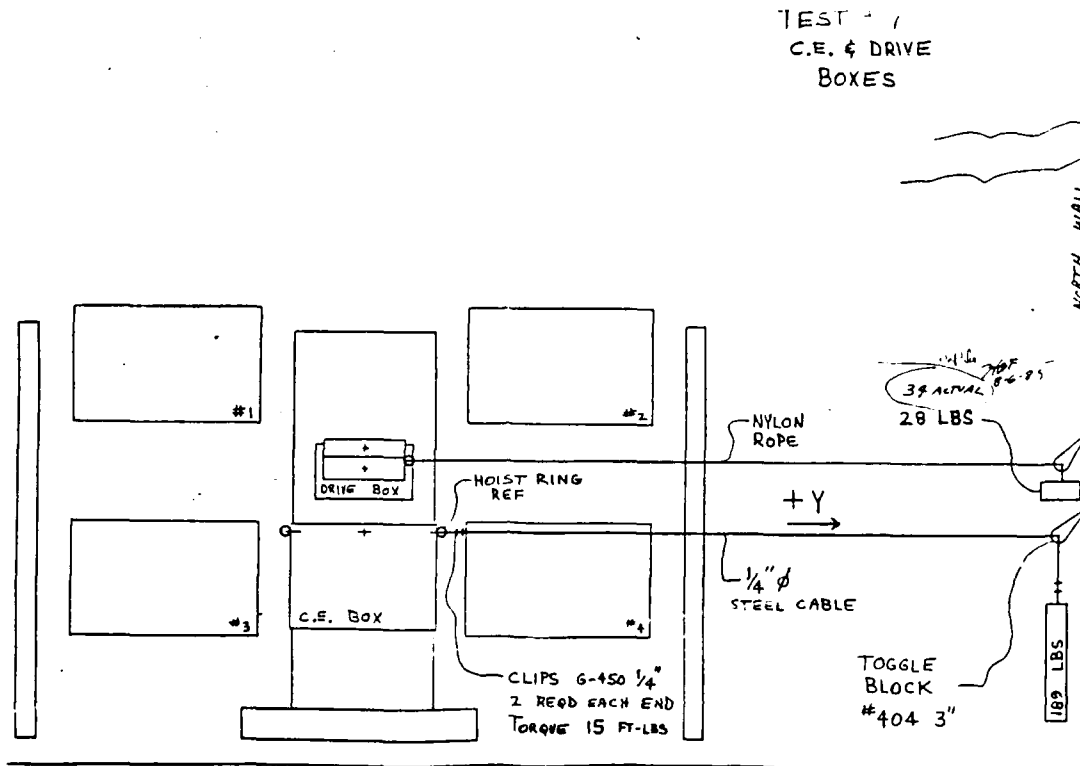

FIGURE 3-27-2 OSSE PROOF MODEL STATIC LOAD TEST



C.E. — 4 FREE WEIGHTS

- X = 206 LBS (+2)
- +Y = 189 LBS
- Z = 446 LBS

DRIVE — 3 FREE WEIGHTS

- X = 29 LBS
- +Y = 28 LBS
- Z = 64 LBS

TEST #7
C.E. & DRIVE
BOXES

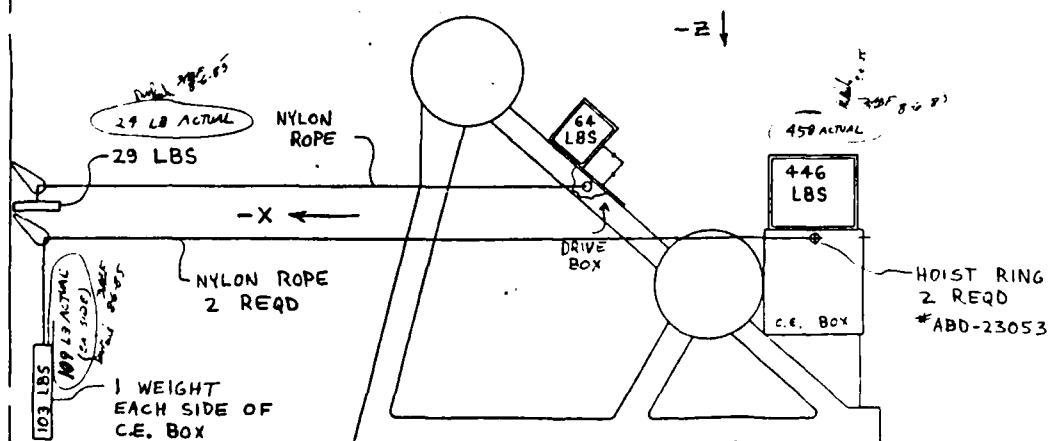

3.5.1.3 PROOF MODEL ACOUSTIC TEST

The Proof Model Structure Acoustic test was performed in September, 1985, at the conclusion of the static-load test series.

The OSSE structure, loaded with the Detector, Central Electronics and Drive Electronics dummy mass simulators, was lifted out of the modal survey pit with the use of the OSSE lifting sling (ref DD150664, Instrument Handling Procedure) after the lifting sling was load-certified. The OSSE Proof Model Structure was placed on the OSSE handling dolly and secured by non-flight bolts at the ten footpads.

The OSSE structure, with simulated loads, was shipped on the handling dolly by truck to the Martin-Marietta acoustic test facility in Littleton, CO. The test procedure in effect was DD150706. A detailed summary of the OSSE flight instrument acoustic test procedure, section 3.5.5, describes the performance of the flight unit acoustic test. This report may, except for dates and certain specifics such as pre- and post-functionals, be indicative of the activity that characterized the OSSE proof model acoustic test, except that test instrumentation was far less comprehensive, and certain aspects of handling, while the requirements were specified for the proof model structure, were not nearly so stringent for this acoustic test as they were for the flight instrument, obviously because of the inherent sensitivity of the detector subsystems, as well as the added value of the completed instrument.

The accelerometers used were the same as for the modal survey, and their positions are shown in FIGURE 3-28-1. Table 3-25 shows the OSSE Qual-Acoustic Excitation Profile, duration 1 minute. Figure 3-28-2 shows the 1/3 octave band frequencies of the actual one minute run.

Examination of the OSSE structure revealed no physical evidence of damage of any sort. A post-acoustic drive functional revealed that the drives all functioned normally. No damage occurred to any OSSE-related equipment, flight and non-flight, during shipment between the BASD and Martin test facilities, nor were there any mishaps of any sort in shipment and handling.

FIGURE 3-28-1 OSSE PROOF MODEL ACCELEROMETER LOCATIONS

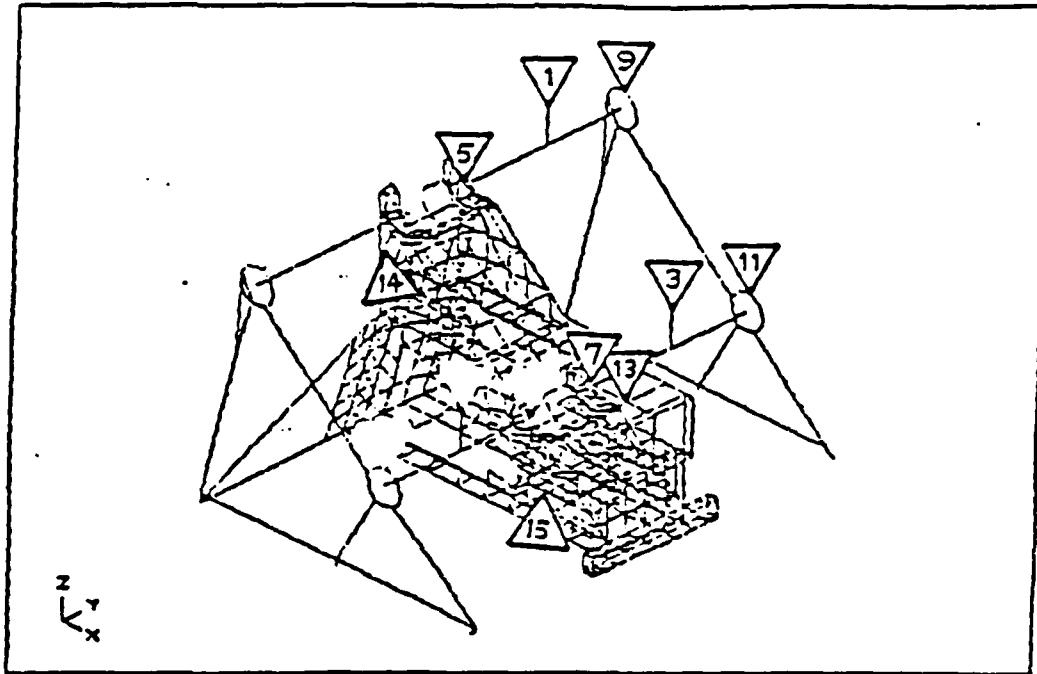

TABLE 3-25 OSSE QUAL-ACOUSTIC EXCITATION PROFILE

OVERALL ACOUSTIC LEVEL -- 142.5dB	DURATION -- 1 MINUTE
<u>1/3 Octave-Band Center Freq. in Hz</u>	<u>Sound Pressure Level (dB re. 20 micro N/m²)</u>
31.5	125
40	128
50	130.5
63	131.5
80	132
100	132
125	132
160	132
200	132
250	132
315	132
400	130.5
500	128.5
630	127
800	125
1000	123
1250	121.5
1600	119.5
2000	118
2500	116
3150	114.5
4000	112.5
5000	111
6300	109
8000	107.5
10000	106

Tolerances: Sound Pressure Level -- 1/3 Octave Band \pm 3dB
 -- Overall \pm 1.5dB

Some third-octave points above 500 Hz may be out of spec. These will be minimized to the best facility capability.

4.0 QUALITY ASSURANCE PROVISIONS

These provisions are derived from the OSSE Performance Assurance Implementation Plan (EX056-001).

FIGURE 3-28-2 OSSE PROOF MODEL ONE MINUTE ACOUSTIC TEST

ACOUSTIC DATA SHEET

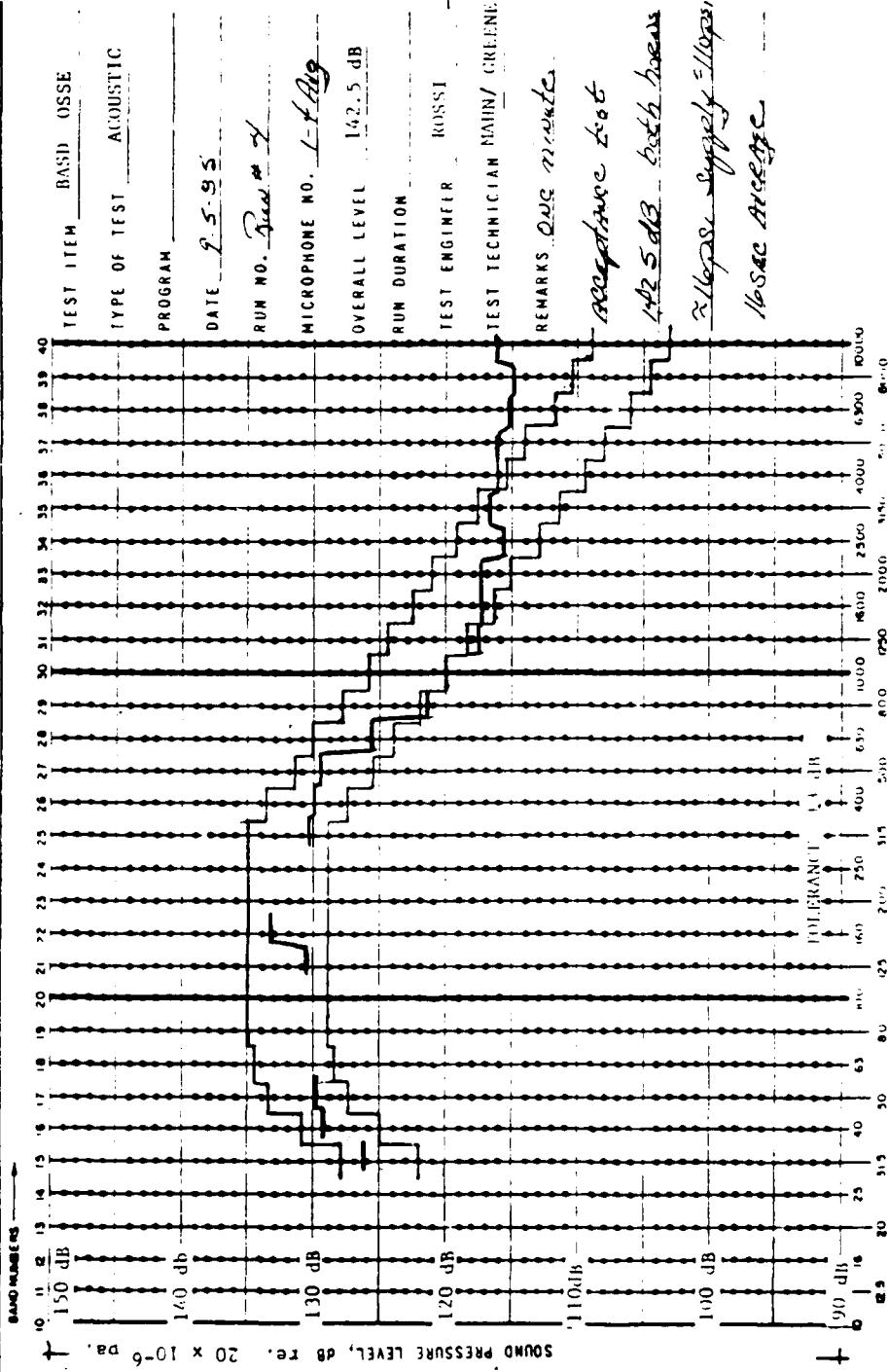

3.5.2 MASS PROPERTIES SUMMARY, WEIGHT AND C.G.

This report summarizes the procedure and results of measuring the weight and center of gravity (on the X-Y plane) of the completed OSSE instrument. The test was performed per procedure DD150717, and completed by 10/10/86.

1. WEIGHT

OSSE was measured as an instrument/dolly system, with the mass properties of the dolly known and factored out by calculation. Two currently calibrated BLH Electronics load cells were placed in the three-point mounting system supporting the instrument/dolly. The third leg was a dummy prop, so one exchange of position of the prop and one load cell was required to obtain all three measurements. The sum of the three readings, plus absent flight hardware and anticipated design growth, and minus the dolly weight and non-flight (red tag) items constitute the weight determination of OSSE, which stood at:

3997 lbs (at completion of test, see Memo 2188-M-86.830 by H.V. Royer, 10/15/87)

This figure was revised toward the end of acceptance testing and calibration, due to the down-scaling of anticipated flight hardware growth, to:

3980 (+/- 5) lbs.

2. CENTER OF GRAVITY ON THE X-Y PLANE

OSSE Center of Gravity on the X-Y plane was calculated using the individual readings of the load cells, and their geometrical placement on the X-Y plane with respect to a specific mounting bolt hole center, located at the -X, -Y corner of the instrument, and defined as X=0, Y=0. From this reference point, the X and Y vectors to the CG point are:

CG of instrument along X axis is -31.666 in.

CG of instrument along Y axis is 38.038 in.

The reference point per TRW-ICD is located on the X-axis mechanical centerline (Y=0), and at a reference point forward of the instrument interface panel (X=0). From this reference point, the X, Y, and Z (calculated) vectors to the CG point are:

ACTUAL CENTER OF GRAVITY

X = -36.04 in.

Y = + 0.03 in.

Z = N/A in.

CALCULATED CENTER OF GRAVITY

X = -36.09 in.

Y = - 0.03 in.

Z = 29.29 in.

The calculated moment of inertia of a rotating detector is less than 10.9 Slug Ft². The calculated instrument inertia is:

ACTUAL INERTIA	CALCULATED INERTIA
N/A	$I_{xx} = 592.0 \text{ Slug Ft}^2$
N/A	$I_{yy} = 361.0 \text{ Slug Ft}^2$
N/A	$I_{zz} = 685.0 \text{ Slug Ft}^2$

3.5.3 OPERATION REPORT: BASELINE FUNCTIONAL TEST

This section summarizes the results of the Baseline Functional Test of the OSSE instrument which was performed at BASD from December 2, 1986 through January 13, 1987. The purpose of the Baseline Functional test was to verify that OSSE complied with its performance specifications stated in the Development Specification (EX056-012D) and the interface Control Document (IF3-1135G). This test also established the performance baseline for subsequent EMI, Thermal Vacuum, and Acoustic tests.

Following is a description of each of the tests that were performed during Baseline testing and a summary of the results and significant anomalies found.

- 1) A full set of ATP's were run on the OSSE instrument to verify the functional performance of major subsystems.
 - a) SYSPEFUNC- This ATP verifies the functionality of hardware and software within the Processor Electronics and its interfaces to the Detectors, Drive Electronics, CPM, PCU, and the spacecraft. This ATP was run for both PEA and PEB.
 - b) SYSDEVER- This ATP verifies the functionality of the Detector in a nominal configuration and collects spectra for all the data collection modes of the Detector. The HITS test cable is not required to be connected to run this ATP. This ATP was run for each of the four detectors.
 - c) SYSDEFUNC- This ATP tests the commandability and functionality of all hardware in the Detector Electronics. It requires that the HITS test cable be connected to each detector's test connector. This ATP was run for each of the four detectors.
 - d) SYSPCOVER- This ATP tests the commandability and functionality of the Power Control Unit and its interfaces to the PE, Detectors, and Spacecraft. This ATP was run for RIUA/PEA and RIUB/PEB combinations.
 - e) SYSDIFLIN- This ATP tests the differential linearity of all signal chains within the Detector Electronics, including the phoswich shield, CPD, and Co60 amplifier chains. This ATP does a brief collection for each of these channels but does not verify the differential linearity performance specifications since the collections are not long enough statistically. This ATP was run for each of the four detectors.
 - f) SYSINTLIN- This ATP tests and verifies the performance specification

for the integral linearity of all signal chains within the Detector Electronics. This ATP was run for each of the four detectors.

- g) SYSPWRUP- This ATP allows a power up configuration to be defined and briefly checks the status of the instrument after configuration. Items that can be selected for configuration are the RIU interface, PE, Detectors, and Drive subsystem. This ATP was run prior to the other ATP's to place OSSE into a known configuration.
 - h) SYSDRIVER- This ATP verifies the functionality of the Drive system including calibration, limit switches, potentiometer readouts, and positioning. This ATP was run for both PEA and PEB.
 - i) SYSPOTLIN- This ATP steps the drives through their total range of motion and reads the potentiometer at each specified position. A step size of two was used during Baseline testing. This ATP was run for both PEA and PEB.
 - j) SYSPULSAR- This ATP tests the functionality of the Pulsar screening process in the Processor Electronics. This ATP was run for both PEA and PEB.
- 2) The RIU electrical interface to the spacecraft was verified using an oscilloscope, logic analyzer, and digital voltmeter. The following items were checked for both RIU interfaces: serial command and telemetry signals, discrete commands, synchronization signals and clocks, RIU analog and bilevel telemetry, and grounding.
 - 3) Single and dual parameter collections were made with Th 228 and Cu-C radioactive sources to verify instrument performance at different energies. Resolution, pulse shape figure of merit, and detector gain were calculated from peak fits of these collections.
 - 4) Background collections were made at different detector angles to verify no magnetic susceptibility or gain change with position.
 - 5) Motor drive calibration strategy tables were developed for each of the four drive subsystems. Separate tables needed to be developed for each of the two Processor Electronics.
 - 6) The Co60 tagging efficiency was measured for each of the four detector subsystems.
 - 7) Tests were performed to verify the opposing detector veto in and out circuitry in each of the detectors as well as the veto matrix contained in the Processor Electronics.
 - 8) Both Charged Pariticle Monitors (CPM) were tested for functionality and gain match.
 - 9) To verify the differential linearity specification, 16 hour DIPLIN collections were made on the low range/low gain, low range/high gain, and medium ranges.
 - 10) Noise tests were performed on all PMT's by collecting a pulsar spectrum

with the PMT high voltage on and comparing it to the same spectrum except with the high voltage off.

11) Miscellaneous functional tests were performed on the Makeup, Active, and Shuttle heaters and their respective control circuits.

12) Operational tests of the flight software processes and formats were performed.

13) An orbital functional simulation (OMOST) test was performed which verified some other instrument operational modes in a flight like configuration.

The following list briefly describes the instrument related anomalies discovered during Baseline functional testing.

1) During a transfer from the main to redundant motors on Detector 1, the transfer was incomplete.

2) Occasional spurious CPU resets were seen throughout baseline testing.

3) Various software problems discovered which are now fixed with uploaded patches to the flight software.

4) Problem with 4 thermistors connected in parallel instead of 2 for control of the CE Makeup heater.

5) Occasional extra step found during runs of SYSPOTLIN caused by a hardware/software misunderstanding of the motor step control circuit in the PE.

6) Aperture size/control coupling problem found with the LED/PIN A system on Detector 3. This unit was subsequently found to be unstable during instrument EMI testing.

All of the above anomalies have been addressed in MDR's, and since resolved.

3.5.4 OPERATION REPORT: OSSE FLIGHT INSTRUMENT THERMAL-VACUUM TEST

3.5.4.1 TEST OBJECTIVE

The purpose of this report is to summarize the performing of the thermal-vacuum test of the OSSE Flight Instrument per BASD Test Procedure, DD150716, wherein the stated objectives are, first, to demonstrate the survivability of OSSE in the 5 to 35 degree C range for three (3) thermal cycles over a minimum of 28 days under vacuum, and second, to validate the steady-state thermal model while demonstrating detector operating temperature controlability in the worst hot and cold orbital environments (5-35 degrees C).

3.5.4.2 FACT SUMMARY:

Chamber:	'BRUTUS', 20 foot dia. x 18 foot high. BASD thermal-vacuum chamber.
Date OSSE installed in chamber:	2/21/87
Pump-down period:	3/05/87 - 3/06/87

Thermal cycling period: Ambient: 3/06/87 - 3/09/87
 Amb to Hot: 3/09/87 - 3/10/87
 Hot #1: 3/10/87 - 3/11/87
 Hot to Hot Orbit: 3/12/87
 Hot Orbit: 3/12/87 - 3/13/87
 (Test Suspension Due to RIU Failure: 3/13/87 - 3/16/87)
 Thermal Balance: 3/16/87 - 3/17/87
 To Cold Orbit: 3/17/87 - 3/18/87
 Cold Orbit: 3/18/87 - 3/20/87
 To Cold: 3/21/87
 Cold #1: 3/22/87 - 3/23/87
 To Hot: 3/23/87 - 3/24/87
 Hot #2: 3/25/87 - 3/26/87
 To Cold: 3/27/87 - 3/28/87
 Cold #2: 3/29/87
 To Hot: 3/29/87 - 3/30/87
 Hot #3: 3/30/87 - 3/31/87
 To Cold: 3/31/87 - 4/01/87
 Cold #3: 4/01/87 - 4/03/87
 To Ambient Temp: 4/01/87 - 4/02/87
 Return to Atmosphere: 4/03/87
 Post Thermal Vac Functional: 4/04/87 - 4/05/87
 Date OSSE removed from Chamber: 4/07/87
 Staffing: Twenty-four hour OSSE test and Brutus operating
 personnel coverage during vacuum conditions
 between 3/05/87 and 4/02/87.

3.5.4.3 RESULTS VS. TEST OBJECTIVE

In actuality, three hot cycles and three cold cycles were completed as specified by this procedure. In addition, there were hot orbit (16 degrees C), cold orbit (10 degrees C), and thermal balance (20 degrees C) periods during twenty eight (28) complete days under vacuum. Validation of the thermal model is beyond the scope of this operation report. Refer to SER EX056A-478.

3.5.4.4 CHRONOLOGY OF TEST MILESTONES:

Prior to the pump-down of the vacuum chamber on 3/05/87, preparations included the following:

- Crane and Lifting Hardware Load Certification

The 'Brutus' thermal-vacuum chamber at BASD is top-loading for large test items such as the OSSE Instrument. The chamber lid weighs in excess of eight (8) tons, and its placement on and removal from the chamber using the overhead crane was adequate as a certifiable load test for the crane and associated lifting hardware required to lift OSSE and its dolly, about 5500 pounds.

- BRUTUS Chamber Interior Arrangements

The interior of the vacuum chamber was configured to accommodate OSSE such that the dolly was isolated from the chamber mounting plate using four (4) thermal isolation blocks (ten thermal isolation blocks were mounted between the OSSE structure and the dolly, one under each footpad, intended as a resistive thermal path closely simulating GRO thermal communication). Scaffolding forming catwalks around OSSE permitted good access and fairly

safe footing. No injuries occurred within the chamber during installation, setup, and removal.

A rack was attached to the chamber lid using a measured chain so it was suspended over OSSE at a pre-determined height. This rack held the two radioactive sources for the 1-3 and 2-4 detector pairs.

Thermocouple instrumentation leads were connected to conventional chamber inside panel connections. Heater cables for inside and outside the chamber were made using hardware compatible with the existing bulkhead connector interface. OSSE cabling from UUT to IGSE units within the control room included a chamber interface bulkhead built for OSSE and adaptable to standard chamber ports such as those on Brutus..

-Exterior Arrangements

OSSE test and Brutus operating personnel resided inside the Control Room along with all operating GSE (with the exception of the VAX computer system, located in another area) during the execution of this test. Cabling was propped over the pit between the chamber and the Control Room using boards and ties.

-Instrument Preparation

The OSSE UUT was configured as described in BASD Drawing 150000. The Instrument is made up of a thermally isolated dolly-mounted Structure supporting all of the Central Electronics, Detector, Drive, Charged Particle Monitor, and Thermal Shield Subsystems.

Heaters, LN2 cooling coils, and insulation blankets were incorporated in the handling dolly design to steer thermal transition, stabilize thermal plateaus, and to simulate spacecraft heat flow. Thermocouples attached to dolly, structure, and thermal shield provided data for the interpretation of heat flow and thermal balancing of the UUT.

2/21/87 OSSE Installed in the Chamber
The movements were without incident or major complication.

2/22/87 - 3/4/87 OSSE Set-up & Functionals
Some final tests were required to finish the EMI procedure which preceded thermal-vacuum. Pre-pump functionals including SYSDEVER, SYSDRIVER, SYSPEFUNC, SYSPULSAR, SYSPCOVER, SYSDEFUNC ATP's, as well as background and gain & energy resolution tests were performed in the manner that such tests will be executed during hot, cold, hot orbit, and cold orbit periods under thermal-vacuum conditions. The EMC/EMI Test Report, APPENDIX 3 of this document, describes these tests in detail.

Note was made of the apparent failure of the A3 AGC system, where LED\$A3 had approximately 150 mv oscillation throughout the test, even before radiation. A broken wire was found and repaired, and LED\$A3 corrected. Ref MDR A61634.

Other broken wire incidents were corrected: (TAW\$# SYS-057, SYS-058).

3/05/87 - 3/06/87 Chamber is Pumped-Down.
After 21 hours, the chamber reached the -6 torr range, and the UUT under the thermal shield was still in the -4 torr range. Decided not to apply power for another 8 hours. After 29 hours, power was applied, and ambient thermal-vac tests begun.

3/06/87 - 3/09/87 Ambient Thermal-Vac Tests Performed.
The tests included the six standard ATP's, the G&E resolution, Gain stability, and Initial HV Turn-on tests.

3/09/87 - 3/10/87 Transition to Hot.
Detector missed-step test was performed during this period.

3/10/87 - 3/11/87 Hot Cycle #1.
The six standard ATP's and the G&E resolution tests were performed.

3/12/87 Transition to Hot Orbit
SYSPOTLIN ATP was performed during this period.

3/12/87 - 3/13/87 Hot Orbit
The six standard ATP's, the G&E resolution, and the Gain Stability tests were performed during this period.

3/13/87 - 3/16/87 RIU Failure Period.
The RIU failed in a serious way, troubleshooting began on 12 March 11:30, and since nothing could be done for a couple days, the thermal environment inside th chamber was safed by jetisonning the LN2 and bringing all systems to ambient temperature.

3/16/87 - 3/17/87 Hot Thermal Balance Period
Hot Orbit Thermal Balance was monitored during this period.

3/17/87 - 3/18/87 Transition to Cold Orbit
Ran SYSDRIVER, G&E tests during this period.

3/18/87 - 3/20, 87 Cold Orbit Thermal Balance Period
Ran the six standard ATP's, G&E resolution tests during this period.

3/21/87 Transition to Cold
Ran SYSPOTLIN ATP during this period.

3/22/87 - 3/23/87 Cold Cycle #1
Ran the six standard ATP's, G&E resolution tests during this period.

3/23/87 - 3/24/87 Transition to Hot
Ran SYSPOTLIN ATP during this period.

3/25/87 - 3/26/87 Hot Cycle #2
Ran the six standard ATP's, G&E resolution tests during this period.

3/27/87 - 3/28/87 Transition to Cold
Ran O.M.O.S.T., SYSPOTLIN ATP during this period.

3/29/87 Cold Cycle #2
Ran the six standard ATP's, G&E resolution tests during this period.

3/29/87 - 3/30/87 Transition to Hot
Ran missed-step test during this period.

3/30/87 - 3/31/87 Hot Cycle #3

Ran SYSPCUVER, SYSDEVER, G&E resolution test.

3/31/87 - 4/01/87 Transition to Cold

Ran mis-step test, took active heater data, ran shuttle and makeup heater tests.

4/01/87 - 4/03/87 Cold Cycle #3

Ran the six standard ATP's, G&E resolution, active, shuttle, and make-up heater tests, some more O.M.O.S.T.

4/03/87 Transition to Ambient Temperature

Ran G&E resolution test.

4/03/87 Return to Atmosphere

Ran the six standard ATP's at ambient temperature and pressure.

3.5.4.5 TEST ANOMALIES

The anomalies noted during thermal-vacuum testing are broken down into the following categories:

1) ATP Data Anomalies. Six (6) ATP's comprise the test routine at the temperature extremes. They are:

- a) SYSDEVER, (ref MDR A61659)
 - 1) AGCON\$BX Reads OFF, Expected ON.
 - 2) ATP Limits Too Narrow.
 - 3) ATP Limits Incorrect.
 - 4) CALIB\$B Reads OFF, Expected ON.

Resolution: Continue to process through calibration.

- b) SYSDRIVER, (ref MDR A61660)
 - 1) ATP Potentiometer Limits Incorrect.

Resolution: Continue to process through calibration.

- c) SYSPEFUNC, (ref MDR A61661)
 - 1) ATP Temperature Limits Incorrect.
 - 2) ATP Rate Limits Incorrect.

Resolution: Continue to process through calibration.

- d) SYSPULSAR, (ref MDR A61662)
 - 1) ATP Rate Limits Incorrect.
 - 2) EBE Epoch Test. Chi 2/Def Errors.
 - 3) ATP Does Not Load Configuration First Time; Does Second Time.

Resolution: Continue to process through calibration.

- e) SYSPCUVER, (ref MDR A61663)
 - 1) ATP CE Makeup Heater Current Limits Incorrect.
 - 2) Motor Power Regulator Select Bilevels (MTRAx\$B) Not Validated Correctly.

Resolution: Continue to process through calibration.

- f) SYSDEFUNC, (ref MDR A61664)
 - 1) ATP Limits Too Tight - Co60 Spectral Memory Counts Out of Tolerance For 200+/-20. Should Be 200+/-30.
 - 2) DVM Returns Zero Value For Good Reading, Occasionally Reads Bad Non-Zero Values.
 - 3) ATP CAL(PIN) Peak Limits Too Narrow.
 - 4) ATP Limits Too Narrow.
 - 5) ATP Deadtime Percentage Limits Too Narrow.
 - 6) ATP RPHA2 High Range Shape Peak Limits Too Narrow.
 - 7) ATP Co60 Section Rates Too Narrow.
 - 8) LED/PIN Module Does Not Function Correctly All The Time. Manual Tests Always Work OK. Limits Too Narrow On FWHM Range.

Resolution: Continue to process through calibration.

2) ATP Operations Anomalies:

- a) 3/06/87, SYSPEFUNC ATP died after trying to load @SYSPEFUNC DEADMAN file. ERR:40C40070, file not found (Ref TAWS# SYS-062).

Resolution: Testing continued, ATP mod required, no defect to UUT or test configuration.

- b) 3/06/87, SYSPWRUP ATP error after trying to load @MDCPEIF File.ERR:40C40070, file not found (Ref TAWS# SYS-063).

Resolution: Same as a).

- c) 3/15/87, SYSDRIVER ATP died after trying to load *SYSDRIVER_SECONDARY_TABLE configuration table (Ref TAWS# SYS-064).

Resolution: Transferred to MDR A61648. Probable flight or ground support software anomaly.

- d) 3/18/87, SYSPCOVER ATP stopped running while running each side of RIU (Ref TAWS# SYS-066).

Resolution: The IEEE process crashed on a bus conflict while on autoscan. Autoscan was not used thenceforth. No hardware defect.

- e) 3/26/87, SYSPCOVER ATP dies as soon as it starts, or after calibrating detectors (Ref TAWS# SYS-071 and TAWS# SYS-072).

Resolution: Transferred To MDR A61625. No hardware defect, or stress on UUT.

- f) 3/30/87, SYSPCOVER ATP, not enough time given after Cal process was started, and ATP went on to next processes before drives were calibrated and moved the required 1000 steps. Happened on RIUA, PEA (Ref TAWS# SYS-077).

Resolution: Transferred to MDR A61638

3. OSSE Flight Hardware Performance Anomalies:

- a) Detector 4 AGC"B" exhibits a shift in gain (Ref MDR A61665).

Resolution: Not yet. problem continues to be under study.

- b) An ASE was noted in the calibration of DE2 And DE1. Appears to be a change in the motor calibration points (Ref MDR A61666).

Resolution: Continue to process through calibration.

- c) SYSDRIVER ATP reports that X-limit switch on DE1 does not turn on. (Ref TAWS# SYS-065)

Resolution: Apparently a hardware problem with limit switch not activating. Examined after thermal vacuum. An incompletely-seated connector was the problem, and modification to the mating hardware solved it.

- d) Data from SYSPULSAR ATP, PEA is bad. Pulsar configuration not being verified (Ref TAWS# SYS-070).

Resolution: Transferred to MDR A61650. Software problem, no hardware defect.

- e) DE3 high voltage did not drop to zero within 8 PKTS of changing to TLMID=10. They did eventually go to zero (Ref TAWS# SYS-074).

Resolution: Transferred to MDR A61651. Interrim disposition: Continue to process.

- f) DE4 motor drive turned off during missed-step test. TLM indicates a positioning error (Ref TAWS# SYS-079).

Resolution: Transferred to MDR A61640. Defective electronic connection.

- g) DE3 did not recalibrate after missed-step test. Main and redundant pots do not match (Ref TAWS# SYS-080).

Resolution: Transferred to MDR A61640. Same problem as described in f).

- h) Pulsar events from unqualified detectors are sometimes getting through the screening process (Ref TAWS# SYS-082).

Resolution: Transferred to MDR A61655.

4) Thermal Vacuum Chamber and OSSE GSE Anomalies:

- a) 3/09/87, apparent leak in dolly LN2 cooling system.

Resolution: No flight hardware defect. Apparent leak did not repeat or affect T-V test. No further action required.

- b) 3/13/87 - 3/16/87, loss of instrument TLM during ATP testing

troubleshooting, with instrument disconnected, indicated that the power supplies in the OPM 23 had gone into thermal shutdown due to cooling fan failure.

Resolution: GSE LVPS was cause of problem - thermal overload
Shut Down RIU. No overstress of flight hardware.

- c) RIU simulator remote link went down while running SYSPOTLIN ATP during transition to hot temperature (Ref TAWS# SYS-068).

Resolution: Problem due to the remote link going down. Commands (eg MDREL) were not getting to OSSE.

- d) 3/28/87, while running O.M.O.S.T. test, pot readings were not updating properly (A3M\$A) (Ref TAWS# SYS-073).

Resolution: Operator error. Using Motor Reg A when Motor Reg B should have been used. No defect.

- e) 3/28/87, O.M.O.S.T. start-up file OMOSTPEA.PRO would not turn on unless discrete command >SSEC ON was sent (Ref TAWS# SYS-075).

Resolution: Operator error. No defect.

FIGURE 3-29 OSSE INSTRUMENT THERMAL VACUUM TEST - As Run 3/5/87 - 4/3/87

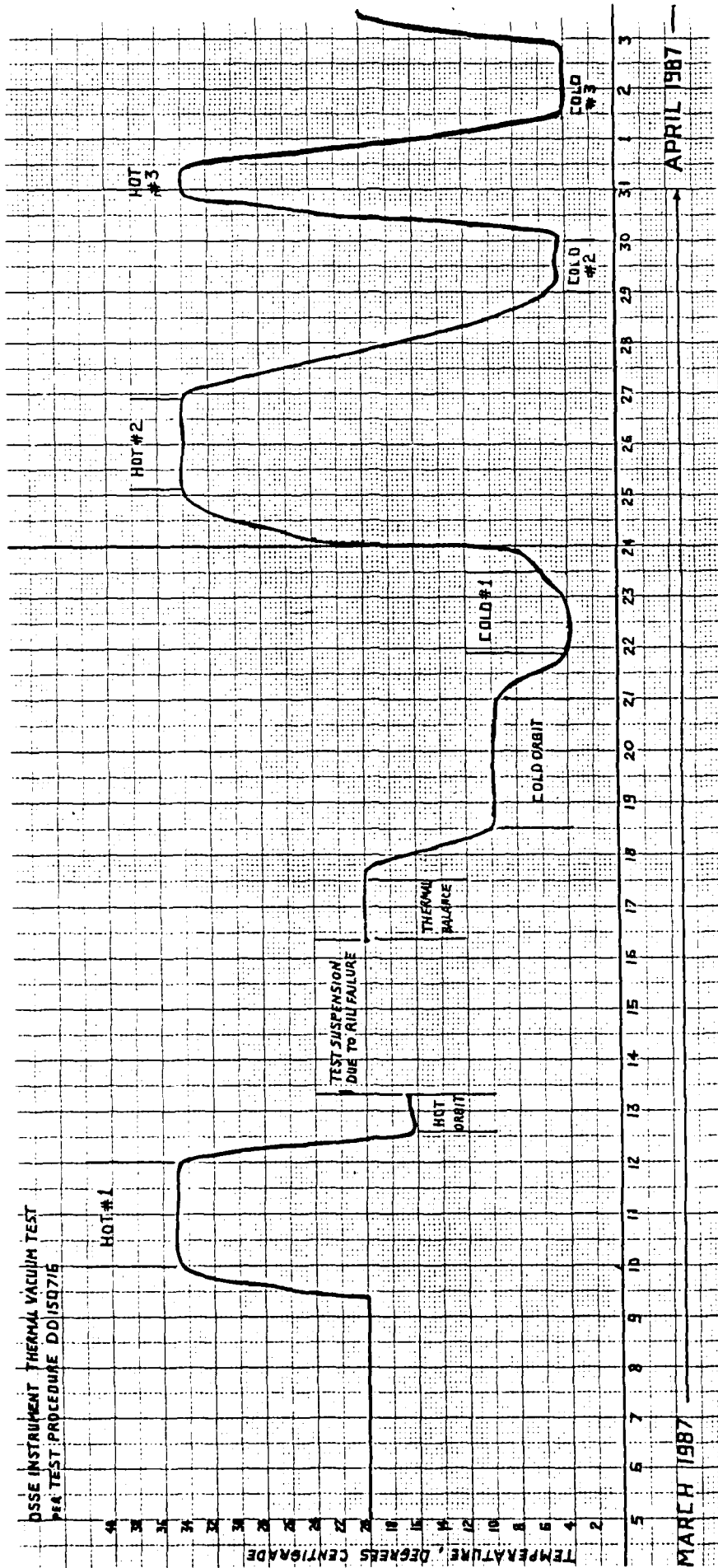

3.5.5 OSSE FLIGHT INSTRUMENT ACOUSTIC TEST

I. Fact Summary: Contractor: Martin Marietta Corp, Littleton, CO.
 Shipping Dates: 5/6/87 and 5/11/87.
 Transport Mode: United Van Lines tractor-drawn trailer, climate controlled, air-ride suspension. Speed limit max: 40mph.
 Motion Shock, Max: 2.8G out to Martin, 2.7G return.
 Distance, RT: Approximately 100 miles.
 Setup at Martin: 5/7/87.
 Actual Test Run: 5/8/87 at 14:12 hours.
 Test Run Duration: <66 seconds.
 Equalization Runs: 26 seconds over two runs.
 Anomalies Noted: Broken ground wire on thermal shroud.
 (before acoustic) Thermal blanket buttons separated from thermal shroud.
 Anomalies Noted: Accel. tri-block #9 separated from Instrument.
 (after acoustic) Accel. #2 became unglued, but not separated, from Instrument.
 Event Anomalies: None. No handling mishaps during (during shipment) moving, loading, or shipment.

This report covers the period between the completion of the pre-acoustic functional test (May 4, 1987) and the beginning of the post-acoustic functional test (May 13, 1987). The companion report submitted by Martin showing the

The accelerometers were mounted prior to the completion of the pre-functional per Test Procedure 158809, Rev B, with the following exception: Accel #1 was mounted on the -X-Y inboardbearing housing instead of the -X+Y unit due to mounting interference. Actual accelerometer locations were photographed prior to departure from BASD.

May 4, 1987

OSSE was wheeled out of Room 5180 (DE Lab) upon completion of functional testing. The Thermal Shroud was lowered by crane and the Instrument covered with ESD-certified bagging material down to the dolly top surface. OSSE was then manually rolled along a swept exterior paved route of about 250 feet between BASD high-bay facilities, en-route to the loading dock. OSSE was kept in the intermediate high-bay staging area in M&PA until the commencement of loading on May 6.

May 5, 1987

No activity.

May 6, 1987

The trailer van was aligned to the BASD dock in such a manner that little ramping was required to bridge the gap from dock to trailer. OSSE was rolled to the dock, safety beams were set up inside the van to prevent the Instrument from rolling out of control down the slight (2 degree) incline of the trailer from back to front.

NOTE: The use of cross beams inside the trailer to stop a runaway roll might be potentially hazardous to persons between the beams and the

wheeled cargo, unless adequate up-side restraint, such as a winch or run-out safety line, is in effect. For this operation, such lines were in use, but even with the up-side restraints, misunderstanding or carelessness could result in leg injuries.

OSSE was manually rolled over the plates and irregularities of the threshold very slowly and carefully, positioned centrally in the trailer, and strapped in place. Cushions were placed around the dolly to absorb side-loads.

Shock recording instrumentation was used to monitor OSSE's movement during the trip. The average acceleration spike was below 1G for any of the three axes monitored for both legs of the trip. The maximum load spike seen by any axis was 2.8G outbound to Martin, and 2.7G inbound from Martin. Refer to the attached charts (Figures 2A-2K, 3A-3D).

The trip to Martin was slightly over two hours, for an average speed of 20 mph. The trailer van was escorted by a lead and a following vehicle at all times. Three-way communication between vehicles by-and-large was coherent and useful, particularly regarding problems with the shock recording instrumentation and road conditions ahead.

The off-loading operation at Martin was the reverse of the loading operation at BASD. The trailer was front-end high at Martin's dock, so the rollout was downhill. The same restraining procedures, and trailer bed-to-dock bridging was used.

Weather conditions at both BASD and Martin, and in-transit, were perfect.

After unloading, OSSE was stored for the night inside Martin's acoustic chamber. Elapsed time dock-to-dock was 6 hours. Personnel involved with the shipping operation included BASD QA (1), Production (2), Test (4), Instrumentation Monitor (1), Shipping (1), and United Van Lines Rep (1), Driver/Loaders (4).

May 7, 1987

Preparation of OSSE for acoustic test began early with the removal of the Thermal Shield. Activities included the following:

1. Recording crystal vacuum pressure.
2. Installing two microphones within the Instrument cavity per DD158809.
3. Stringing out accelerometer and microphone cables for outside access and hookup.
4. Re-attaching Thermal Shield to Instrument.
5. Buttoning-up Thermal Blanket. Installing stiffener (which resulted in breaking off two standoffs).
6. Positioning OSSE in Acoustic chamber, orienting it the same as the proof model tested in September, 1986.
7. Covering OSSE, lowering chamber, locking up for the night.

May 8, 1987

Martin personnel hooked up accelerometer and microphone cables to respective control and data apparatus. A record of Martin-furnished equipment, by model, serial number, and cal-due dates, is attached to the end of this report.

The acoustic setup check (per DD158809 sect. 6.1) consisted of two equal-

ization runs at full level for a combined total of 26 seconds. A third run would have exceeded the maximum exposure time of 30 seconds and was therefore not done. However, the final adjustments to refine the octave-band for the actual 60 second test were made by calculation, and in any event the required adjustments were minor.

The 60 second qualification run was done at 14:12 hours. The actual elapsed time was less than 66 seconds. A printout of the 1 minute qual test spectrum is attached to the end of this report. The Martin report will discuss this data more comprehensively.

OSSE was covered and secured in the chamber for the weekend.

May 9 and May 10, 1987

No activity.

May 11, 1987

OSSE was examined in-place inside the acoustic test chamber, with the thermal shield on. The only anomaly noted was two thermal blanket buttons missing, apparently because their snap rings popped out of the grooves during the acoustic test.

Martin agreed to permit BASD to keep Martin microphones on OSSE until they could be removed at BASD and returned to Martin by mail. This was done by May 14th. This permission saved OSSE one thermal shield removal and replacement cycle, allowed more careful examination of the interior condition of OSSE without being rushed, and allowed photographic record of the microphone placement and accelerometer condition.

All cables were disconnected from OSSE by the time the van arrived at 10 am. OSSE was loaded onto the van without incident. The inclination of the trailer bed (up from rear to front) made winch-pulling of the Instrument over the dock ramps, and up into the center of the trailer, a necessity.

All GSE, and the transport shock monitoring system, were on-board and secured to the satisfaction of BASD PEQA by 12:00 noon. The van was escorted by front and rear BASD cars, and the three vehicles were in radio communication. The trip lasted two hours, and a third hour was needed to repair a malfunction in the shock monitoring equipment just after departing the Martin compound. Otherwise, the journey was eventless.

The weather conditions during loading were perfect, and during transport, occasionally stormy with lightning and light showers.

OSSE was pulled out of the van and onto the BASD dock with the help of a fork-lift used as a tractor. OSSE was moved manually immediately into the M&P-A high-bay to its new situation for post-acoustic functional testing, and calibration.

Weather conditions during the unloading at BASD were cloudy, no rain, and stable. Participants in the return of OSSE from Martin were the same as for the outgoing trip, minus several United Van lines personnel.

The performance of the United Van Lines representative and driver/loader personnel is to be commended for being outstanding in proficiency,

patience, and courtesy throughout the entire moving operation.

May 12, 1987

The thermal shield was removed from OSSE. The Instrument was examined and photographed. Accelerometers located at position #9, a tri-axial mount, were found detached from the electronics stack on detector A2. The accelerometer located at position #2 was found detached from the central electronics box +Z face (AIL #81).

Other anomalies included: Torn kapton on thermal shroud where it covers the central electronics box (AIL #78), and peeling black paint on A4 detector and A1 electronics box (AIL #79, not necessarily related to the acoustic test).

FIGURE 3-30 ACOUSTIC TEST SPECTRUM, ONE MINUTE QUAL

FIGURE 1.6-1 OSSE INSTRUMENT ACOUSTIC TEST SPECTRUM, ONE MINUTE QUAL

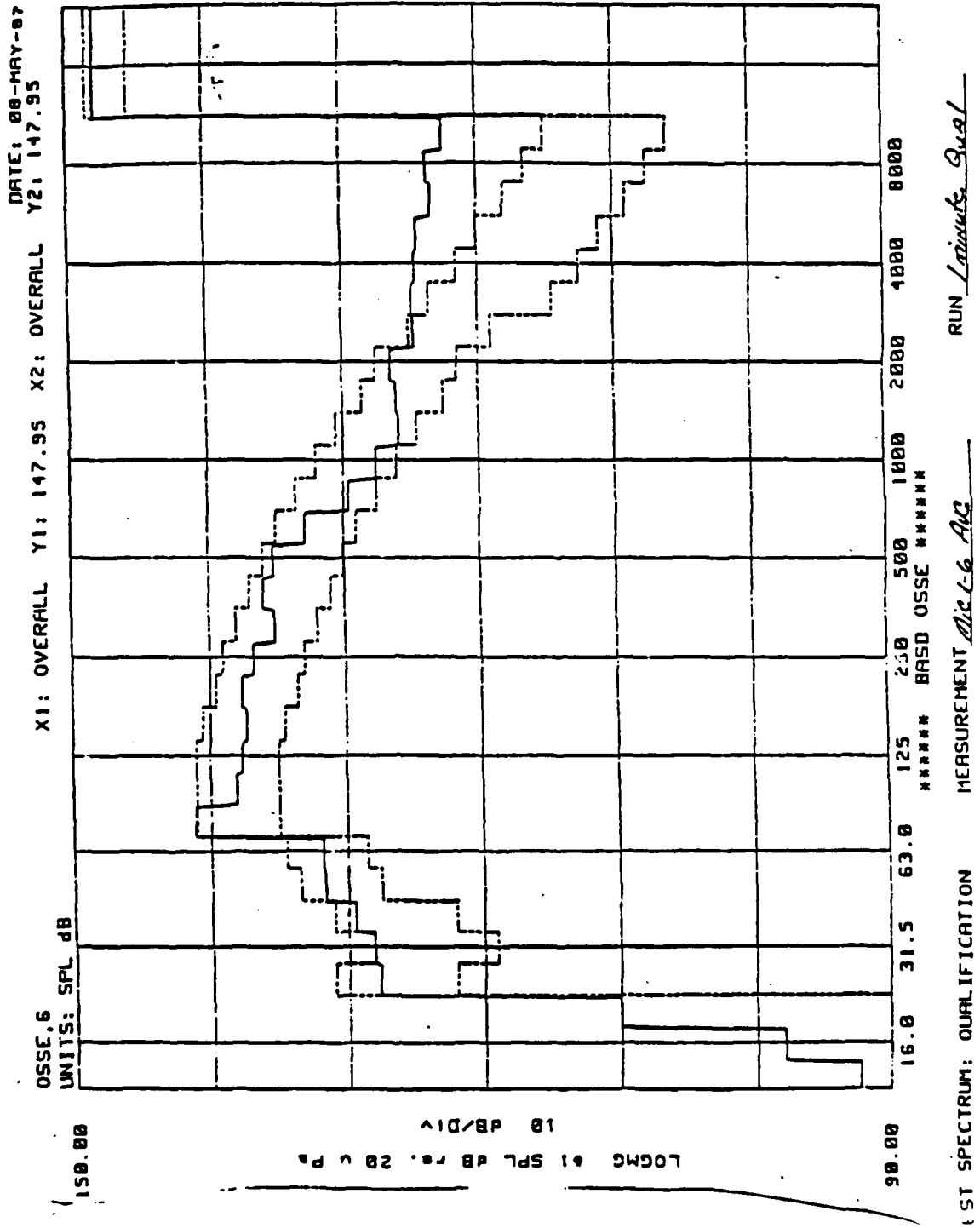

TEST SPECTRUM: OURLIFICATION

3.5.6 OPERATION REPORT: OSSE POST-ACOUSTIC FUNCTIONAL TEST

This section summarizes the results of the Pre and Post-Acoustic Functional Tests of the OSSE instrument which were performed at BASD from from April 27, 1987 through May 28, 1987. The purpose of the Acoustic Functional Tests were to verify that no electrical failures occurred as a result of vibration experienced during the Acoustic test. The Pre-Acoustic test provided a reference to which the Post-Acoustic data was compared. Test procedure DD150710 was in effect.

Following is a description of each of the tests that were performed during Pre and Post-Acoustic functional testing and a summary of the results and significant anomalies found.

- 1) A full set of ATP's were run on the OSSE instrument during the Pre-Acoustic test to provide a reference point in the event of a failure. The same tests were performed during the Post-Acoustic test and the data was then compared to the Pre-Acoustic test data.
- a) SYSPEFUNC- This ATP verifies the functionality of hardware and software within the Processor Electronics and its interfaces to the Detectors, Drive Electronics, CPM, PCU, and the Spacecraft. This ATP was run for both PEA and PEB.
- b) SYSDEVER- This ATP verifies the functionality of the Detector in a nominal configuration and collects spectra for all the data collection modes of the detector. The HITS test cable is not required to be connected to run this ATP. This ATP was run for each of the four detectors.
- c) SYSDEFUNC- This ATP tests the commandability and functionality of all hardware in the Detector Electronics. It requires that the HITS test cable be connected to each detector's test connector. This ATP was run for each of the four detectors.
- d) SYSPCUVER- This ATP tests the commandability and functionality of the Power Control Unit and its interfaces to the PE, Detectors, and Spacecraft. This ATP was run for RIUA/PEA and RIUB/PEB combinations.
- e) SYSPWRUP- This ATP allows a power up configuration to be defined and briefly checks the status of the instrument after configuration. Items that can be selected for configuration are the RIU interface, PE, Detectors, and Drive subsystem. This ATP was run prior to most of the other ATP's to place OSSE into a known configuration.
- f) SYSDRIVER- This ATP verifies the functionality of the Drive system including calibration, limit switches, potentiometer readouts, and positioning. This ATP was run for both PEA and PEB.
- g) SYSPOTLIN- This ATP steps the drives through their total range of motion and reads the potentiometer at each specified position. A step size of eighteen was used during Acoustic testing. This ATP was run for both PEA and PEB.
- h) SYSPULSAR- This ATP tests the functionality of the Pulsar screening

process in the Processor Electronics. This ATP was run for both PEA and PEB.

- 2) Single and dual parameter collections were made with a Th 228 radioactive source to verify instrument performance at different energies. Gain and stability were measured during this test.
- 3) A special CPD test was performed before and after the Acoustic test as a result of an anomaly with the Detector 2 CPD gain found during the Thermal Vacuum test. This test measured the gain of each of the CPD's by collecting a CPD spectrum with a Th 228 source placed in the center of the CPD.
- 4) Before sending the instrument to the Acoustic test at Martin Marietta, all four detectors were calibrated and positioned to the +Z axis where the launch lock was set. The purpose of this was to see how much the detectors moved during the shipping and Acoustic test. The first test performed in the Post-Acoustic functional was to measure the detector positions.
- 5) A long (32 hour) missed step test was performed as a part of the Post-Acoustic test to verify the missed step error rate was within specification. This test involved calibrating the detectors and positioning them to the +Z axis before the start of the test. The detector positions were measured with a theodolite for comparison to the final detector positions. The test was then started using a 49% drive duty cycle that ran for 32 hours to accumulate 2.0 million steps on each drive. At the completion of the test, the detector were commanded to the +Z axis where their positions were again measured with a theodolite. No missed step errors were found during this test.

No instrument related anomalies were discovered during Acoustic functional testing.

3.5.7 EMC/ EMI TEST SUMMARY

THE ELECTROMAGNETIC COMPATIBILITY/ELECTROMAGNETIC INTERFERENCE (EMC/EMI) TEST REPORT FOR THE OSSE INSTRUMENT is included in this report as Appendix 3.

OSSE LESSONS LEARNED

4.0 OBJECTIVE

This discussion will consider a few of the many thousands of decisions that were made during design, fabrication, and test of the Oriented Scintillation Spectrometer Experiment (OSSE) instrument. While it is inevitable that some decisions were made that perhaps turned out not to be the best course of action, the cumulative result of all program actions produced a Gamma Ray Observatory experiment that has been performing to expectations during months of ground test and calibration. This exceedingly complex yet reliable experiment will provide significant advances to the field of gamma ray astronomy as a result of the contributions of the many people at NRL, GSFC, BASD and others who participated in this program.

The following list is a summary of technical program activities at BASD that encountered more than the expected level of difficulty, and should be evaluated when tradeoffs are performed on future programs. Some suggestions and alternatives are included, but of course detailed tradeoffs have not been made and specific applications may have different requirements and require different approaches. The methods actually used on OSSE did achieve an acceptable but perhaps not optimal result. It is hoped that consideration of these items will lead to improved capabilities in space hardware.

The final section considers actions which were particularly successful and would be recommended for incorporation into future program planning.

The list has been grouped into electrical and mechanical categories.

4.1 Electrical Improvements

1. Use PC board-mountable connectors instead of hardwiring connectors to the board. The hardwiring resulted in extensive hand labor in cramped spaces which could be reduced.
2. Use a motherboard approach to the DE interconnections. The board commonality savings achieved were offset by the DE cabling complexity.
3. Use shaft angle encoders instead of potentiometers for drive angle readout. While initially more expensive and complex, the encoders probably would have significantly reduced the need for test and calibration, and provided higher pointing accuracy.
4. Feedback of detector position information to the drive control would have simplified drive testing and added to the certainty of the positioning.

5. Part procurement and screening delays, especially among nonstandard parts caused schedule and planning problems during all phases of the program. A list of "parts to avoid" because of reliability or availability problems and reduced use of non-Preferred Parts List (PPL) parts in the design may aid future programs.
6. Bleeder strings were not optimally matched to the delivered PMT characteristics and were difficult to modify after assembly. Improved performance in this area would probably require additional efforts in component selection and test.
7. Performance and reliability studies of connector cleaning and lubrication effects would produce definitive, demonstrated recommendations. The relatively large number of connectors and repeated mate-demate cycles such as on an instrument as OSSE may produce reliability concerns even with relatively low failure rates.
8. A PCU engineering model would have assisted verification of the complex wiring and early discovery of current monitor EMI susceptibility had it been part of the program. Insufficient extra packaging volume caused difficulty in assembly and test and in incorporating the changes necessitated by the growth of requirements.
9. Selection of a different CPU chip would have allowed for more effective processor architecture.

4.2 Mechanical Improvements

1. A rigid self-supporting interface specified for the OSSE side of the spacecraft mounting interface would have simplified lifting and handling, tooling, assembly, test interfaces, and alignment determinations.
2. Pressurization of crystal chambers instead of using guard vacuum would have simplified the design and assembly, and made leakage easy to detect and safer for the hardware.
3. A flight qualified pumpout manifold would have reduced the detector pumpout schedule.
4. A LED/PIN assembly that used more of the available volume would have reduced signal crosstalk, assembly, and rework difficulties that resulted from its small size.
5. Proper loading of PMTs was difficult and may be easier with a different mechanical design.
6. Studs and locking nuts would be preferable to the existing bolts and nutplates used to attach DE modules. The present method is difficult to assemble and would require substantial repairs if a locking nutplate galls during assembly or repair.

7. Central Electronics cables had too much excess length, and access to connectors on the back was difficult. Some DE cables did not have enough excess length for easy handling during assembly. Cable routing and supports should be incorporated early in the mechanical layout.
8. Development of collimator fabrication methods was risky and expensive. Although the resulting collimators were excellent, another method may have produced adequate collimators at less risk to the program.
9. Bearing seals incorporated in the outboard bearing housing design would prevent entry of contamination without the need to install and remove non-flight shields.

4.3 Special Successes

Two particularly successful areas stand out among the many which contributed to the overall success of OSSE and should certainly be considered for future programs.

1. Bench checkout units (BCU)

Bench checkout units for the processor and detector electronics paid for themselves many times during testing of flight boards through substitution. The thorough and comprehensive testing in actual operating conditions undoubtedly prevented many problems from arising only after the individual subsystems were integrated. In addition, they provided the "Engineering Model" function of training production and test personnel on the special requirements of the OSSE boards, and they allowed development of test procedures, software and tooling without hazard or schedule impact to flight boards. They have also been very valuable for assessment, simulation, and troubleshooting of the subtle timing effects discovered during the detailed data analysis by NRL. The ability of the BCUs to continue to support this type of activity through the remainder of ground test and after launch may prove to be their most important contribution yet to the understanding of the data received from orbit.

2. Science Team Support

Beginning during the OSSE thermal vacuum test, NRL provided nearly continuous science team support to the test and calibration effort which resulted in significantly improved understanding of both mission requirements and instrument operation by NRL and BASD. The thermal vacuum performance tests and calibration provided answers to the questions raised by the detailed data analysis being done during those times. There is a much higher level of confidence in the data generated by OSSE since it has been analyzed from engineering and science viewpoints. This cooperation was essential for explaining some performance aspects, and sufficiently beneficial to the test program overall that it should be considered on future projects.