

DTIC FILE COPY

To be published Nuclear Instruments & Methods in Phys. Research A  
contract # N00014-86-C2421  
approved for public release; unlimited distribution

①

AD-A221 267

**Final Design and Cold Tests of a Harmonic Ubitron Amplifier**

H. Bluem<sup>†</sup>, R.H. Jackson, and D.E. Pershing<sup>‡</sup>  
Vacuum Electronics Branch, Code 6840  
Naval Research Laboratory  
Washington, D.C. 20375  
phone: (202) 767-3936  
fax: (202) 767-0546

J.H. Booske and V.L. Granatstein  
Laboratory for Plasma Research  
University of Maryland  
College Park, MD 20742

**1988**

Abstract

A harmonic ubitron amplifier has been designed and is nearing final assembly. The experiment is intended to be a proof-of-principle study of the feasibility of harmonic operation of the ubitron. Harmonics are a key in reducing the high voltage requirements of ubitrons. The configuration of the experiment consists of a 250kV/100A electron gun, an input transition from single mode to overmoded waveguide, a linear wiggler, mode selective output couplers, and a calorimeter/water load. The design and goals of the overall experiment will be discussed along with the design and test results of individual components

DTIC  
ELECTE  
MAY 01 1990  
S a B D

<sup>†</sup>Laboratory for Plasma Research, University of Maryland, College Park, MD 20742

<sup>‡</sup>Mission Research Corporation, Newington, VA 22122

DISTRIBUTION STATEMENT A

Approved for public release;  
Distribution Unlimited

90 04 30 091

INTRODUCTION

Harmonic operation of the ubitron/free electron laser (FEL) is a promising method to relieve the voltage requirements for achieving a given operating frequency. Higher harmonics are especially important in the microwave and millimeter wave regimes where the high voltage nature of the ubitron interaction is a serious drawback for certain applications, and where short period wigglers are impractical due to the large gap sizes necessary to allow microwave propagation. In this region, the voltage reduction scales as  $1/n^2$  (as opposed to  $1/\sqrt{n}$  at higher voltages, where  $n$  is the harmonic number). Harmonics can also be used to extend the operating frequency of any fixed voltage FEL. A number of studies have looked into harmonic generation in a planar wiggler FEL using linear theory [1-4] or nonlinear analysis [5,6] and indicate that the gain and the efficiency at higher harmonics can be a substantial fraction of that found in the fundamental interaction when beam thermal effects are small.

The purpose of this experiment is to demonstrate that harmonics can be utilized to dramatically reduce the voltage required to amplify at a given frequency while still achieving a respectable gain and efficiency. The main focus will be on the third harmonic interaction in a linear wiggler FEL, with the fundamental (first harmonic) interaction below waveguide cutoff. This is another important feature of harmonics at the lower frequencies compared to higher frequency. The waveguide dispersion properties can be exploited to control the interaction and prohibit the fundamental from having a resonant intersection. This will make the third harmonic the 'fundamental', since it is the first interaction to have an intersection with the appropriate waveguide dispersion curve. It also means that the third harmonic interaction will be due solely to the third harmonic present in the unperturbed wiggle motion, with no contribution from nonlinear bunching of the electron beam in a first harmonic interaction. The experiment will also include an examination of the second harmonic periodic position interaction as well as the first harmonic ubitron interaction. Voltage tuning will be used to scan through these widely separated interactions and the wiggler field will be adjusted to optimize each. The results for the first through third harmonics will be compared to a three dimensional nonlinear computer code [5] which has also been used to aid in the design of the experiment. The predicted untapered efficiencies for the first through third harmonics are 15%, 7%, and 3% respectively for an electron beam with no initial axial velocity spread. An axial velocity spread lowers the efficiency of all the harmonics, being more severe as the harmonic number increases. However, a tapered wiggler has been shown to offset the effects of axial velocity spread.[7] The predicted efficiency for the third harmonic with a wiggler field taper and no initial axial velocity spread is 21%.

To facilitate direct comparison with the computer code the experiment consists of a solid cylindrical electron beam inside a smooth wall rectangular waveguide. The interaction is between either the  $TE_{01}$  rectangular waveguide mode or the  $TE/TM_{11}$  modes and the undulating electron beam. The wiggler field is provided by a linear electromagnet wiggler. The RF is coupled in and out by

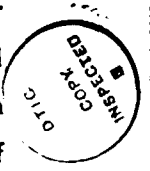

or	<input checked="" type="checkbox"/>	<input type="checkbox"/>	<input type="checkbox"/>
n			
/			
/ Codes			
nd/or			
Dist	Special		
A-1			

broadband mode selective couplers, and the calorimeter/water load provides a matched termination.

Components of the experiment are presently undergoing cold test and calibration with final assembly and operation expected soon. In the following, the choice of experimental parameters is discussed along with the design and cold test performance of individual parts.

## EXPERIMENTAL DESIGN

The experiment is a basic proof-of-principle study of harmonic operation in the ubitron and is designed, within the constraints of existing equipment, to allow same frequency operation at the fundamental as well as the higher harmonics through voltage tuning. The maximum voltage is 250 kV. The interaction frequency was chosen to be in Ku band (12.4 to 18 GHz) and the interaction waveguide was chosen to be standard WR137 waveguide for ease of construction. With these bounds given, the wiggler period and field are chosen. As such, the experiment is not optimized for operation at a specific harmonic. The complete experimental parameters for the first through third harmonics are given in Table I, and a schematic of the ubitron is shown in Figure 1.

As can be seen from the table and as stated earlier, the second harmonic requires a different waveguide mode than the first or third to achieve gain. Thus, the input coupler must be able to selectively launch either mode into the overmoded guide. It must also be broadband and efficient for maximum flexibility in the experiment. A design which satisfies these requirements consists of two Ku band waveguides operating in the  $TE_{10}$  mode combining, via a taper, in the interaction waveguide. They enter on opposite sides of the larger guide and a symmetrical tapered insert matches them into the interaction region. A hole is bored in the center of the taper piece to allow beam transmission. A diagram of the input coupler configuration can be seen in Fig. 1. By controlling the relative phase of the two input arms, the mode of the launched RF wave can be controlled. When the two arms are in phase a  $TE_{01}$  mode is launched, and when they are  $180^\circ$  out of phase the  $TE/TM_{11}$  mode pair is established.

The coupler was cold tested by splitting the input signal with an H-plane tee and feeding the two equal amplitude, equal phase signals into the input coupler ports. After propagating down a length of overmoded WR137 waveguide, a  $TE_{01}$  to  $TE_{10}$  mode taper is used to match the RF in the WR137 guide to a single mode WR62 guide in which the measurement can be made. The cold test circuit is shown in Figure 2, and the transmission loss is shown in Figure 3. The attenuation of the waveguide has been subtracted out of the measurement. The coupling is relatively flat over the entire band with an average coupling of approximately -1.0 dB. The evenly spaced dips in the transmitted power (they are most obvious from 15-18 GHz) are due to spurious mode resonances.[8,9] These resonances occur because any modes other than the  $TE_{01}$  which are excited in the large waveguide become trapped between the  $TE_{01}$  to  $TE_{10}$  taper and the input coupler. Since prior tests found negligible mode conversion in the  $TE_{01}$  to  $TE_{10}$  mode taper, the unwanted modes must be excited in the input coupler or possibly at misaligned

joints. From the depth of the resonance dips the spurious mode amplitudes are calculated to be at least 10 dB below the  $TE_{01}$  mode power.

A linear electromagnet wiggler is used to couple the electron beam to the signal injected by the input coupler. The design used is an eight layer REEL wiggler.[10] The benefits of the REEL wiggler, documented in ref. [10], include current multiplication, reduced end effects, reduced side asymmetries, and lower stray fields from the current leads. A pulsed current supply is used to power the wiggler to avoid thermal problems. Because of the pulsed field, the interaction waveguide is made of stainless steel to reduce diffusion losses. Although the design itself is scalable to submillimeter periods, the period of the wiggler for this experiment is 3 cm due to the large waveguide size needed for such low frequencies. Even with a 3 cm period, the gap to period ratio is fairly large at 0.6, so the wiggler is limited to fields less than 2 kG. There is a four period input taper and a similar output taper. The undulator has a total length of 30 periods, with an extra 10 periods to be added on as an enhancement taper. Wiggle plane focussing is provided by extending the pole pieces partially down the sides of the waveguide. This focusing scheme has the additional benefit of smoothing out the exponential dependence of the field on gap spacing, thereby reducing the effect of period to period gap errors.

To analyze the amplified signal a set of mode selective directional couplers and a calorimeter are used. A total of three couplers are employed to assist in determining the waveguide modes present in the interaction. They couple from the overmoded WR137 waveguide to single mode WR62 guide. Eleven modes can propagate below 18 GHz in WR137 waveguide. However, since the  $TE_{x0}$  modes are not launched in significant amounts by the input coupler and the ubitron should not interact with these modes, they will be ignored. This leaves seven modes. Mode selectivity is achieved by taking advantage of the field patterns of the various modes at the walls of the waveguide and the fact that only normal electric fields and tangential magnetic fields can couple through the holes. A sidewall to broadwall coupler is used to sample all the modes. A broadwall to sidewall coupler with the coupling holes at  $a/4$  in the broadwall (where  $a$  is the width of the broadwall) samples the  $TE_{01}$ ,  $TE_{11}$ , and  $TE_{31}$ . A broadwall to sidewall coupler with the holes at  $a/2$  in the broadwall couples out the  $TE_{01}$  and  $TE_{21}$  modes. These three couplers, along with frequency information, should be sufficient to verify the amplified modes. If they prove to be insufficient an additional coupler can easily be added to the experiment due to the modular nature of the design. The output couplers will be used to obtain frequency, mode, waveshape and phase information. In tandem with the calorimeter, they will also provide an accurate measure of the ubitron's output power.

The calorimeter is of the water flow type and doubles as a water load. The load consists of an elliptical pyrex cone which is inserted into the overmoded waveguide and filled with water. The water filled cone provides a low VSWR, broadband, multimode load with good power handling capabilities. Teflon spaghetti tubing brings water to the tip of the cone, and the water exits through the rear of the cone. Both the input and output water temperatures are measured with a set of four

thermistors connected in series to provide high sensitivity. The calorimeter configuration is shown in detail in Figure 4. This configuration is capable of measuring a temperature difference of less than  $0.01^{\circ}\text{C}$  at flow rates less than  $100\text{ml}/\text{min}$ .

The experiment also employs two resistive current monitors. One before and one after the interaction region. The DC breaks are built into the vacuum flanges to minimize the upstream drift tube length and to minimize the effect of the downstream monitor on the RF.

## SUMMARY

A ubitron experiment designed to amplify higher harmonics with the first harmonic below cutoff is in the final stages of construction. The design allows same frequency operation of the first through third harmonics with voltage tuning. The key components of the experiment include a  $\text{TE}_{01}$  mode launcher, a REEL wiggler, mod selective output couplers, and a calorimeter/water load. The experiment will be a proof-of-principle study in utilizing harmonics to significantly lower the voltage requirements of ubitrons.

## ACKNOWLEDGEMENTS

This research is supported by the Office of Naval Research and the Office of Naval Technology. The authors would like to acknowledge useful discussions with and assistance from Dr. Henry Freund and Mr. Frank Wood.

## REFERENCES

- [1] R.C. Davidson, *Phys. Fluids* 29, 267 (1986).
- [2] W.B. Colson, *Phys. Rev. A* 24, 639 (1981).
- [3] H. Al-Abawi, G.T. Moore, and M.O. Scully, *Phys. Rev. A* 25, 426 (1982).
- [4] C.J. Elliot and M.J. Schmitt, *IEEE Trans. Plasma Sci.* PS-15, 319 (1987).
- [5] H.P. Freund, C.L. Chang, and H. Bluem, *Phys. Rev. A* 36, 3218 (1987).
- [6] H. Bluem, H.P. Freund, and C.L. Chang, *Nuc. Instrum. Meth. Phys. Res.* A272, 579 (1988).
- [7] H.P. Freund, H. Bluem, and R.F. Jackson, to be published *Nuc. Instrum. Meth. Phys. Res.*
- [8] J.S. Butterworth, A.L. Cullen, and P.N. Robson, *Proc. I.E.E.* vol. 110, 848 (1963).
- [9] John L. Doane, *IEEE Trans. Microwave Theory Tech.* MTT-36, 1033 (1988).
- [10] R.H. Jackson and H. Bluem, these proceedings.

harmonic no.	1	2	3
waveguide mode	TE <sub>01</sub>	TE/TM <sub>11</sub>	TE <sub>01</sub>
voltage (kV)	250	120	55
current (A)	15	15	10
B <sub>w</sub> (kG)	1.5	1.5	1.0
waveguide height (cm)	1.58		
waveguide width (cm)	3.48		
R <sub>b</sub> (cm)	0.25		
l <sub>w</sub> (cm)	3		
frequency (GHz)	12.4-18		

Table I. Harmonic ubitron experimental parameters.

## FIGURE CAPTIONS

- Figure 1. Schematic of the harmonic ubitron amplifier configuration.
- Figure 2. Input coupler cold test configuration showing the input coupler and the  $TE_{01}$  to  $TE_{10}$  mode transducer which together act as a cavity for spurious modes.
- Figure 3. RF power transmission versus frequency for the input coupler launching a  $TE_{01}$  mode.  
The test set up is shown in Figure 2.
- Figure 4. Schematic of the calorimeter circuit. Inset shows the cross-section of cone and waveguide.

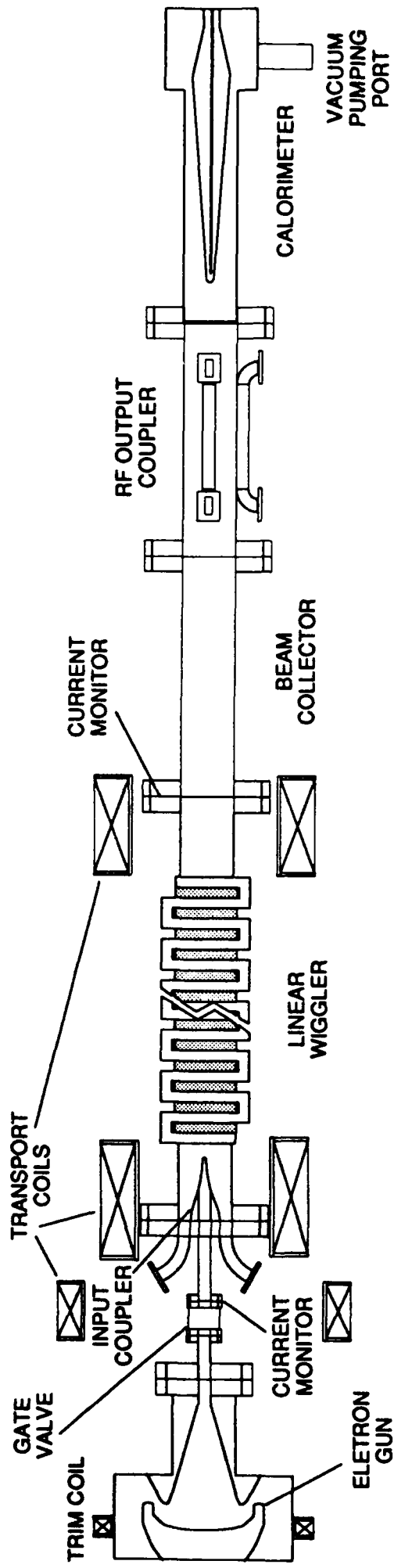

Figure 1

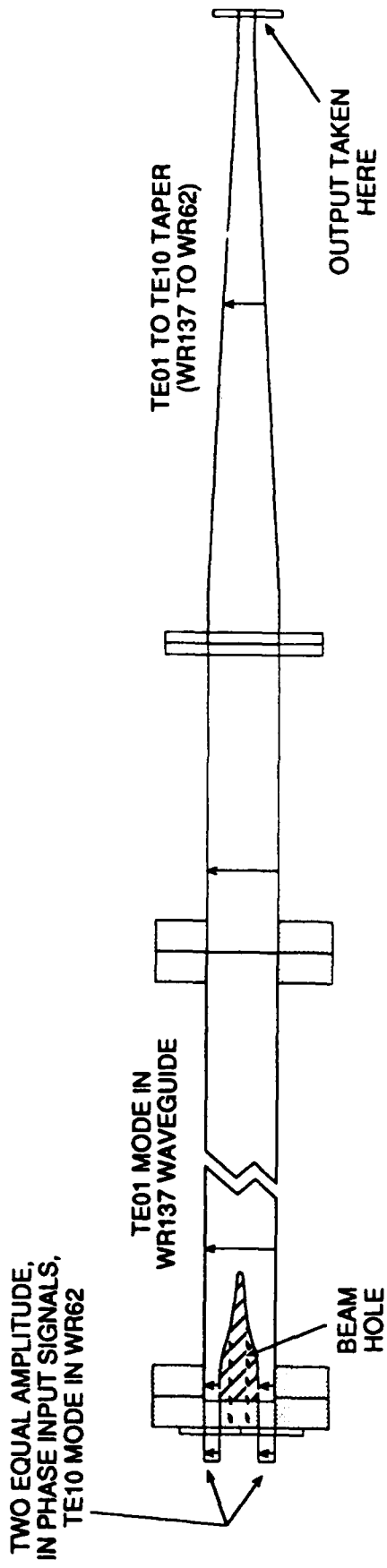
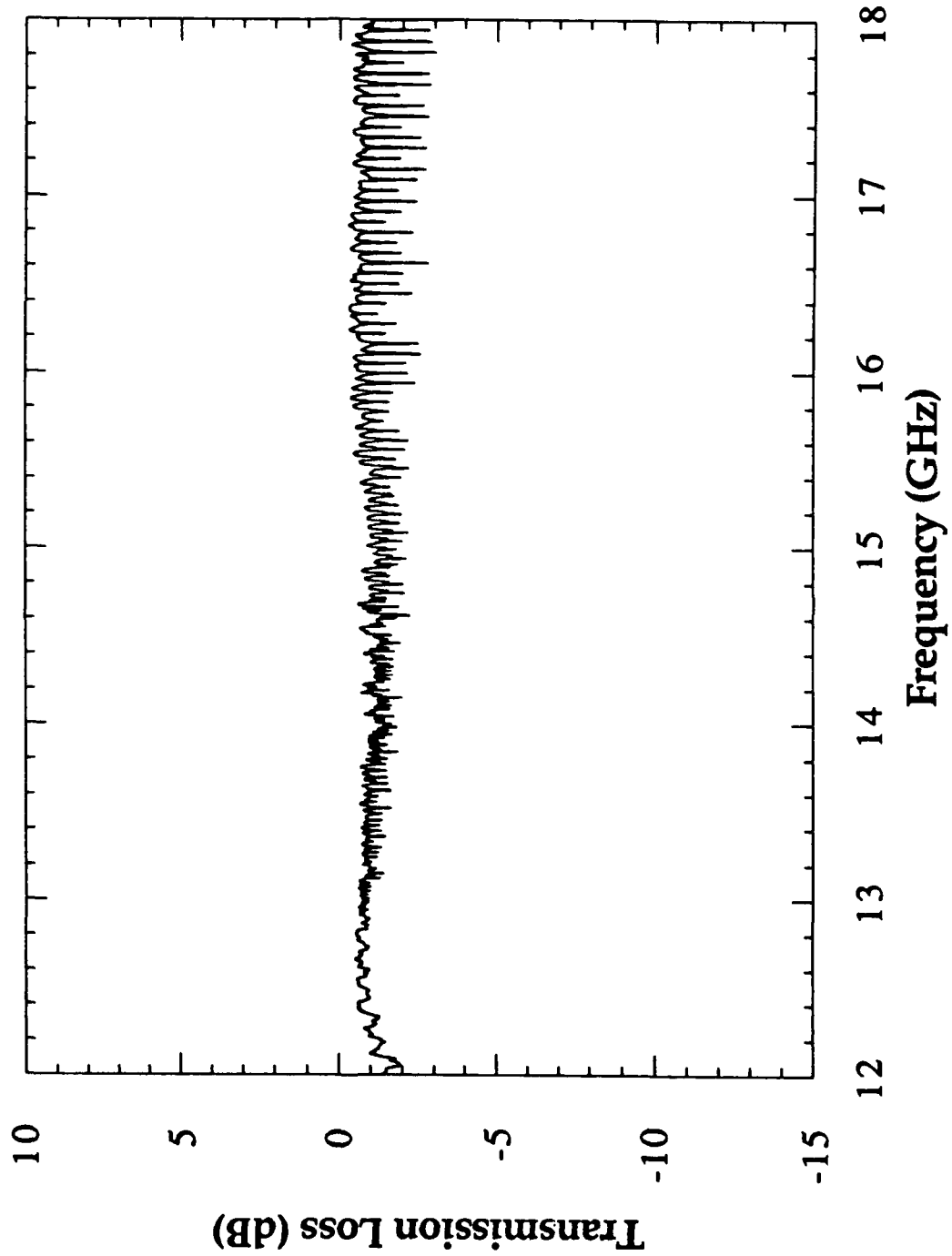

Figure 2



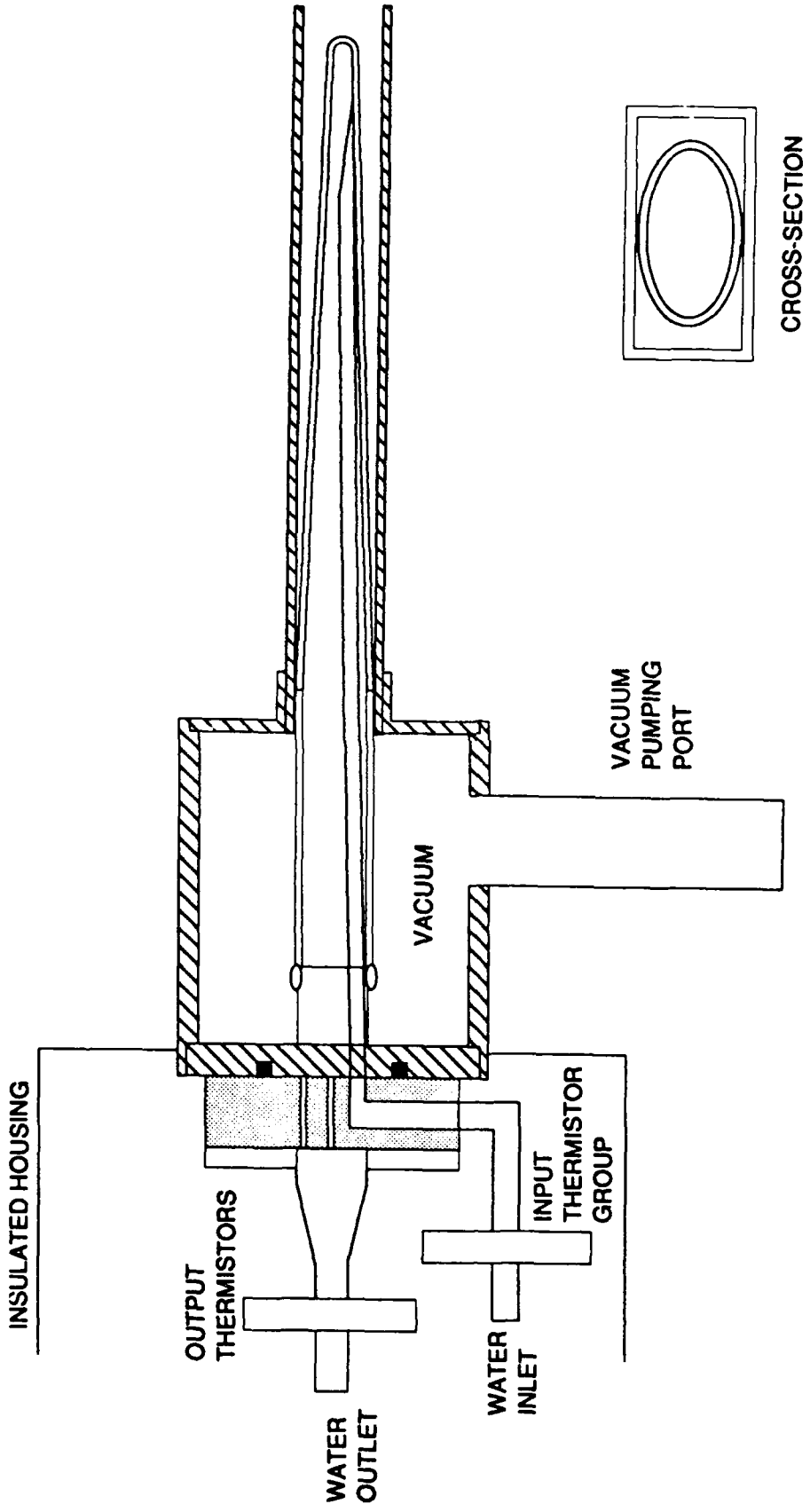

Figure 4