

GL-TR-89-0182

BERMUDA IONOSONDE TESTS IN SUPPORT OF OTH-B

David F. Kitrosser  
Klaus Bibl  
Jane Tang  
Terence W. Bullett

University of Lowell  
Center for Atmospheric Research  
450 Aiken Street  
Lowell, Massachusetts 01854

July 1988

Scientific Report No. 11

Approved for public release; distribution unlimited.

GEOPHYSICS LABORATORY  
AIR FORCE SYSTEMS COMMAND  
UNITED STATES AIR FORCE  
HANSCOM AIR FORCE BASE, MASSACHUSETTS 01731-5000

DTIC  
ELECTE  
MAY 01 1990  
S E D

AD-A221 315

"This technical report has been reviewed and is approved for publication"



ANTONIO QUESADA  
Contract Manager



WILLIAM K. VICKERY  
Branch Chief

FOR THE COMMANDER



ROBERT A. SKRIVANEK  
Division Director

This report has been reviewed by the ESD Public Affairs Office (PA) and is releasable to the National Technical Information Service (NTIS).

Qualified requestors may obtain additional copies from Defense Technical Information Center.

If your address has changed, or if you wish to be removed from the mailing list, or if the addressee is no longer employed by your organization, please notify AFGL/DAA, Hanscom AFB, MA 01731. This will assist us in maintaining current mailing list.

Do not return copies of this report unless contractual obligations or notice on a specific document requires that it be returned.

REPORT DOCUMENTATION PAGE

Form Approved  
OMB No. 0704-0188

1a. REPORT SECURITY CLASSIFICATION Unclassified		1b. RESTRICTIVE MARKINGS	
2a. SECURITY CLASSIFICATION AUTHORITY		3. DISTRIBUTION/AVAILABILITY OF REPORT Approved for public release; distribution unlimited.	
2b. DECLASSIFICATION/DOWNGRADING SCHEDULE			
4. PERFORMING ORGANIZATION REPORT NUMBER(S) ULRF-452/CAR		5. MONITORING ORGANIZATION REPORT NUMBER(S) GL-TR-89-0182	
6a. NAME OF PERFORMING ORGANIZATION University of Lowell	6b. OFFICE SYMBOL (if applicable)	7a. NAME OF MONITORING ORGANIZATION NorthWest Research Associates, Inc. ✓	
6c. ADDRESS (City, State, and ZIP Code) Center for Atmospheric Research 450 Aiken Street Lowell, MA 01854		7b. ADDRESS (City, State, and ZIP Code) 300 120th Avenue, NE Bellevue, WA 98005	
8a. NAME OF FUNDING/SPONSORING ORGANIZATION Geophysics Laboratory	8b. OFFICE SYMBOL (if applicable) LIS	9. PROCUREMENT INSTRUMENT IDENTIFICATION NUMBER F19628-87-C-0003 ✓	
8c. ADDRESS (City, State, and ZIP Code) Hanscom AFB Massachusetts 01731-5000		10. SOURCE OF FUNDING NUMBERS	
		PROGRAM ELEMENT NO. 62101F	PROJECT NO. 4643
		TASK NO. 10	WORK UNIT ACCESSION NO. AC
11. TITLE (Include Security Classification) Bermuda Ionosonde Tests in Support of OTH-B			
12. PERSONAL AUTHOR(S) David F. Kitrosser; Klaus Bibl; Jane Tang; Terence W. Bullett			
13a. TYPE OF REPORT Scientific #11	13b. TIME COVERED FROM _____ TO _____	14. DATE OF REPORT (Year, Month, Day) 1988 July	15. PAGE COUNT 28
16. SUPPLEMENTARY NOTATION			
17. OSATI CODES		18. SUBJECT TERMS (Continue on reverse if necessary and identify by block number)	
FIELD	SUB-GROUP	Radiated Power; Automatic Ionogram Scaler; Digisondes; Attenuator; Interference; Clipper; (TEDC)	
19. ABSTRACT (Continue on reverse if necessary and identify by block number) Through evaluation of low power test results obtained during low power tests conducted on the Digisonde 256 at the Wallops Island Flight Facility, VA in June 1986, the RFI committee (P-043) established that further testing was required prior to authorization of permanent installation of the Digisonde 256 on NAS Bermuda in support of the East Coast OTH-B radar system. As a result, a site survey was required to identify an acceptable location for locating the Digisonde 256 with follow-on temporary deployment of a Digisonde 256 and performance of a two week operational low power test and follow-on data evaluation. The low power tests and evaluation were required to confirm: 1) that low power ionosonde transmissions would not provide interference to Bermuda military or commercial HF users; 2) that acquisition of received ionospheric echoes is sufficient to adequately support the Automated Real Time Ionogram Scaler with True Height (ARTIST). Keywords: Over-the-horizon Radar; Backscattered signal; Naval air stations; Radiofrequency interference; Ionograms;			
20. DISTRIBUTION/AVAILABILITY OF ABSTRACT <input type="checkbox"/> UNCLASSIFIED/UNLIMITED <input type="checkbox"/> SAME AS RPT <input type="checkbox"/> DTIC USERS		21. ABSTRACT SECURITY CLASSIFICATION Unclassified	
22a. NAME OF RESPONSIBLE INDIVIDUAL Antonio Quesada		22b. TELEPHONE (Include Area Code)	22c. OFFICE SYMBOL GL/LIS

## TABLE OF CONTENTS

	Page
1.0 INTRODUCTION	1
2.0 SITE SURVEY AND DIGISONDE INSTALLATION	3
3.0 INTERFERENCE TESTING, DANIEL'S HEAD FACILITY	5
4.0 INTERFERENCE TESTING, ASWOC FACILITY	10
5.0 IONOGRAM AUTOMATIC REAL TIME SCALER - PERFORMANCE ASSESSMENT	13
6.0 RECOMMENDATIONS FOR PERMANENT DEPLOYMENT	16
7.0 REFERENCES	18

### APPENDIX A    Digisonde Remote Terminal Operation



<b>Accession For</b>	
NTIS GRA&I	<input checked="" type="checkbox"/>
DTIC TAB	<input type="checkbox"/>
Unannounced	<input type="checkbox"/>
Justification _____	
By _____	
Distribution/ _____	
<b>Availability Codes</b>	
Dist	Avail and/or Special
A-1	

## LIST OF FIGURES

Figure No.		Page
1	Bermuda Receive Antenna Array	4
2a	Bermuda Digisonde 256 Attenuator Configurations	6
2b	Bermuda Digisonde 256 Attenuator Configurations (Continued)	7
3	Bermuda Digisonde 256 Attenuator Circuit Diagrams	8
4	Bermuda Radiated Power vs. Frequency	9
5	Bermuda Digisonde 256 Clipper Circuit Diagram	11
6	Comparison of ARTIST and Manually Scaled foF2 Values	14

## 1.0 INTRODUCTION

Through evaluation of low power test results obtained during low power tests conducted on the Digisonde 256 at the Wallops Island Flight Facility, VA in June 1986, the RFI committee (P-043) established that further testing was required prior to authorization of permanent installation of the Digisonde 256 on NAS Bermuda in support of the East Coast OTH-B radar system. As a result, a site survey was required to identify an acceptable location for locating the Digisonde 256 with follow-on temporary deployment of a Digisonde 256 and performance of a two week operational low power test and follow-on data evaluation. The low power tests and evaluation were required to confirm: 1) that low power ionosonde transmissions would not provide interference to Bermuda military or commercial HF users; 2) that acquisition of received ionospheric echoes is sufficient to adequately support the Automated Real Time Ionogram Scaler with True Height (ARTIST).

The primary user concerned with HF interference from the ionosonde was the Canadian Forces located at the Daniel's Head facility. Through insertion of frequency dependent attenuators within the Digisonde transmitter, interference was reduced to an acceptable level for the Canadian Forces, however, it was learned that even at this level the Digisonde was generating interference to the Anti-Submarine Warfare Operations Center (ASWOC) receivers located nearby. Through continued tests using first passive clippers and then active clippers, the interference problem was resolved to the satisfaction of the ASWOC.

Comparison of the ARTIST data obtained during the two week low power testing and manual scaling of same was conducted. Conclusions from this comparison revealed that operation of the low

power Digisonde 256 did not significantly affect the ability of the ARTIST to automatically scale the resultant ionograms.

## 2.0 SITE SURVEY AND DIGISONDE INSTALLATION

In August 1987 personnel from the University of Lowell Center for Atmospheric Research (ULCAR), Electronic Systems Division, and Air Force Geophysics Laboratory conducted a site survey. At that time the Air Force decided that the only site on Navy property for the TCI 613 Digisonde antenna that would meet both Airfield and NASA radar constraints was the "Chief's Beach" location. The site picked for the Digisonde trailer was next to the "Water Catchment." Placing the seven receiving loop antennas on top of the water catchment results in nearly a level array and is close enough to the trailer for the standard 500 foot receiving loop cables to suffice. See Figure 1 for schematic of temporary Digisonde installation.

Installation of the trailer and the seven loop antennas was accomplished by ULCAR personnel in October 1987. ULCAR supplied 2200 feet of low-loss Andrews Heliac cable to couple the Digisonde to the transmit antenna (TCI 613 installation arranged by SRI International).

The surplus TCI 613F AWS antenna was returned to the University of Lowell for storage.

# ANNIE'S BAY

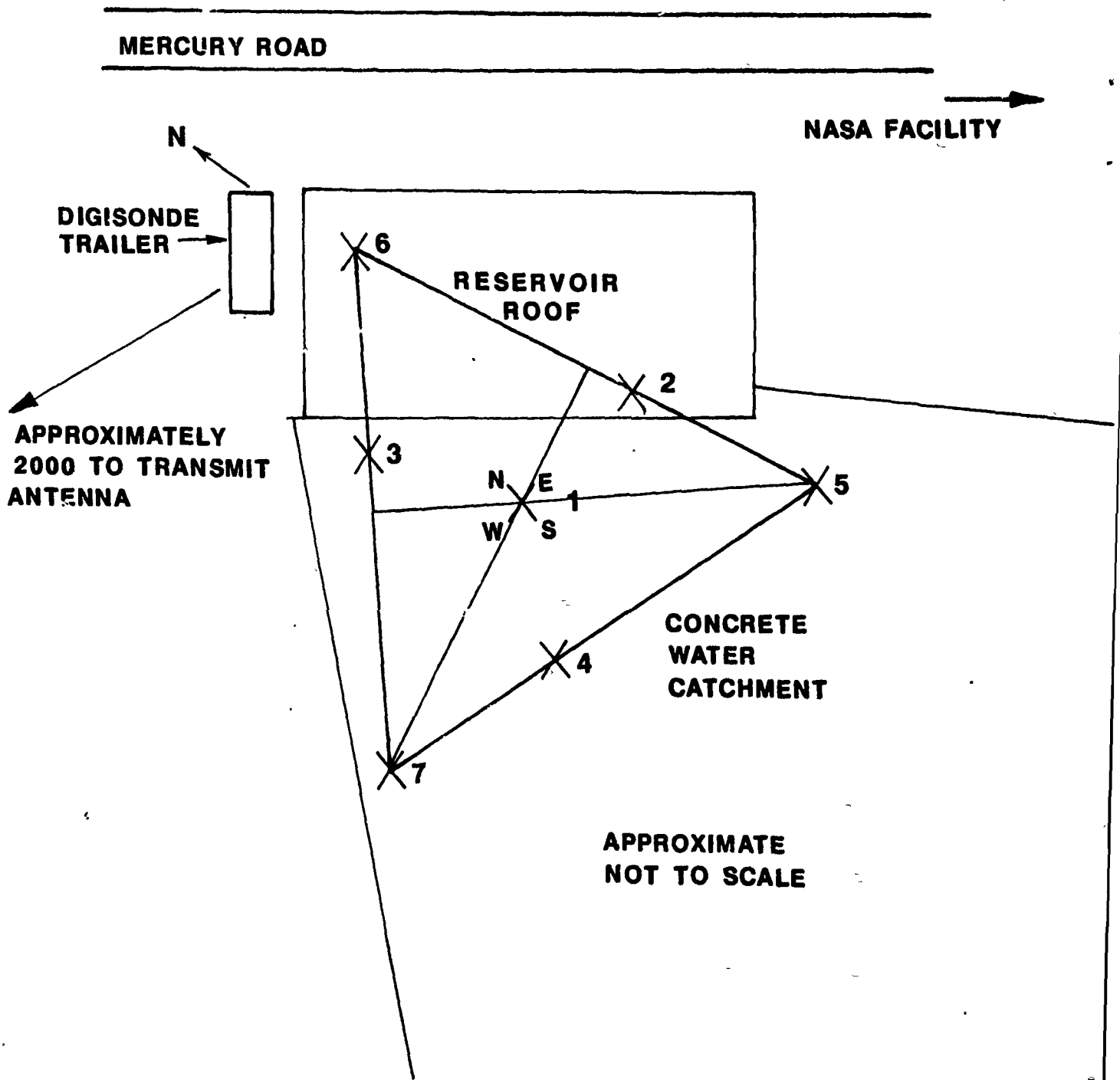

Figure 1. Bermuda Receive Antenna Array

### 3.0 INTERFERENCE TESTING, DANIEL'S HEAD FACILITY

A test program to study the interference from the sounder transmitter to the Canadian Forces equipment at Daniel's Head was commenced in November 1987 under the supervision of SRI. ULCAR operated the Digisonde for a two and one-half week period in normal swept ionograms as well as fixed frequency modes. Frequency dependent attenuators were inserted between stages of the transmitter to keep the power output of the transmitter into the antenna cable under 100 Watts for frequencies below 10 MHz and under 200 Watts between 10 and 15 MHz. See Figures 2 and 3 for attenuator configurations and circuit diagrams. See Figure 4 for radiated power versus frequency. This frequency dependent scheme helped accommodate the sensitivities of the Canadians, the frequency dependent loss characteristics of the transmit antenna coax cable, and the requirements of the sounder receiver to overcome frequency dependent man-made noise.

The Canadian Forces at Daniel's Head were provided a standard AN/FMQ-12 remote terminal and modem, enabling them to remotely shut down the Digisonde if the Digisonde interfered with their operation. The remote terminal also permits the Canadians to obtain ionograms for potential use as a frequency management tool for their operations.

As shown in Figure 2 an initial attenuator configuration was implemented to reduce output power throughout the entire operating frequency range to 100 Watts. Due to external noise being generated by ASWOC equipment in the 10 MHz to 15 MHz band, the output power was increased to 200 Watts for frequencies greater than 7 MHz.

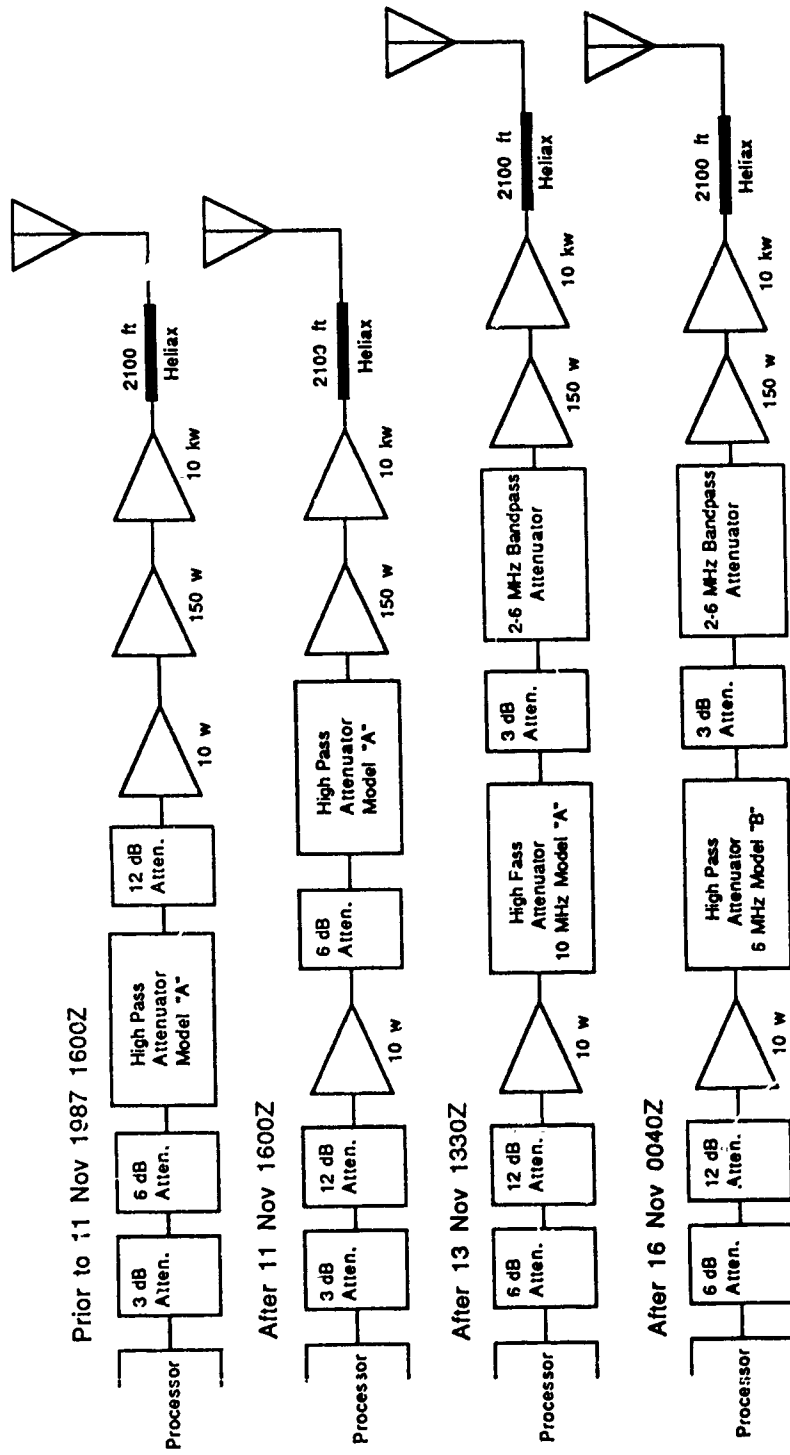
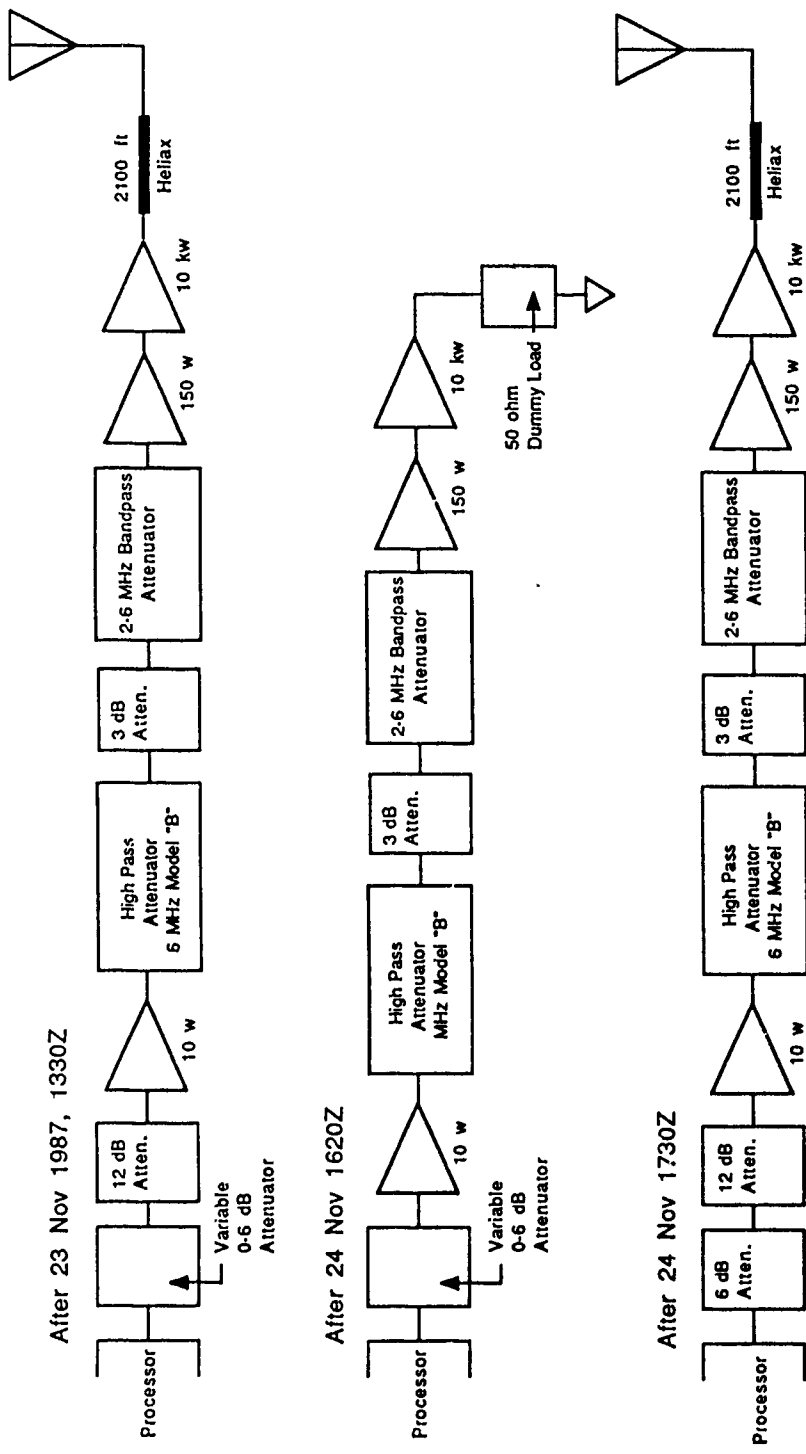

Figure 2a. Bermuda Digisonde 256 Attenuator Configurations



After 23 Nov 1987, 1330Z

After 24 Nov 1620Z

After 24 Nov 1730Z

Figure 2b. Bermuda Digisonde 256 Attenuator Configurations (Continued)

HIGH PASS ATTENUATOR MODEL "B" (6MHZ)

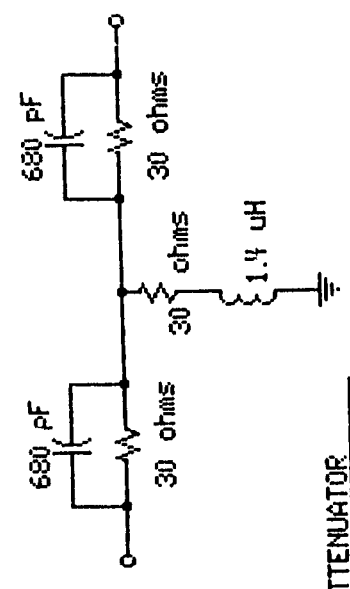

HIGH PASS ATTENUATOR MODEL "A" (10MHZ)

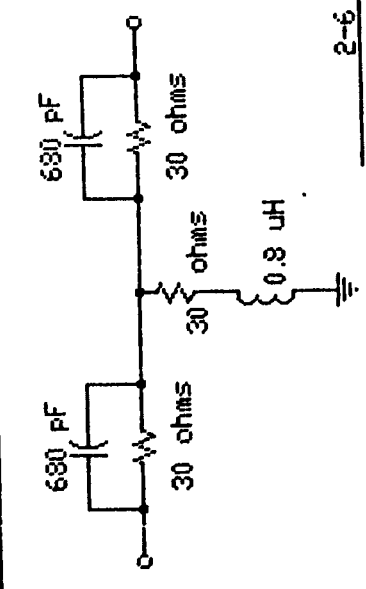

2-6 MHZ BANDPASS ATTENUATOR

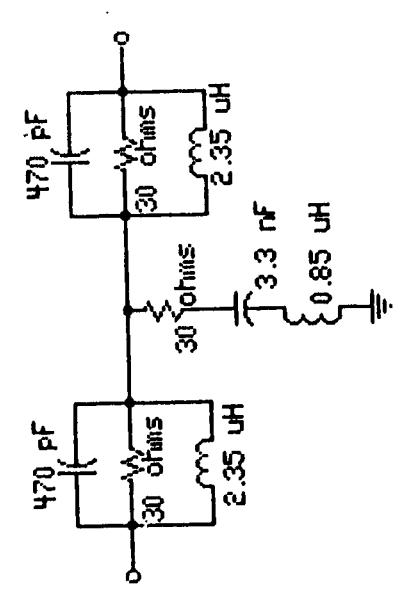

Figure 3. Bermuda Digisonde 256 Attenuator Circuit Diagrams

# Radiated Power, Bermuda Digisonde

as of November 20, 1987

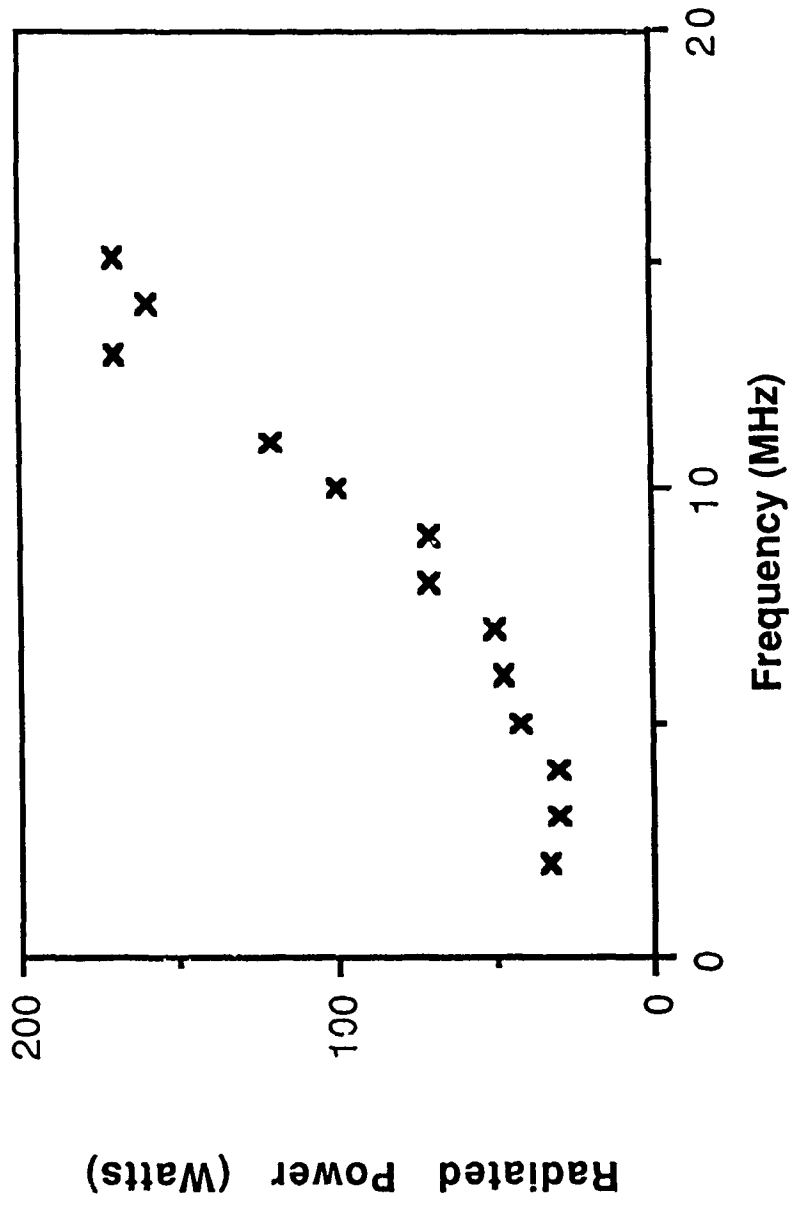

Figure 4. Bermuda Radiated Power vs. Frequency

#### 4.0 INTERFERENCE TESTING, ASWOC FACILITY

The outcome of this testing was that apparently the Canadians could live with the operating Digisonde, but complaints from a nearby Anti-Submarine Warfare Operations Center (ASWOC) were received. The hitherto undisclosed, but rather important, HF use in Bermuda by the Navy is the communications with low flying aircraft. Unfortunately the receiving antennas for ASWOC were as close as 400 feet to the Digisonde transmitting antenna, a fact which was not discovered during the extensive site survey.

To eliminate the direct interference of the Digisonde transmissions to the ASWOC receivers a passive amplitude clipper was tried between the receivers and the receiving antennas in early December. The antenna clippers were effective in that they prevented overloading the ASWOC receivers by the Digisonde pulses but, unfortunately, the diodes used in the clipper caused secondary cross-modulation interference from other strong HF signals.

Later in December a prototype "active" clipper or blanker, Figure 5, which used a signal obtained from the slightly modified nearby Digisonde (700 feet) to blank the ASWOC receiver during the Digisonde's transmitted pulses was installed. This technique relies on the low duty factor (2%) property of the Digisonde's transmitted signal and the ASWOC's use of single sideband suppressed carrier communication and proved completely successful in eliminating direct interference of the Digisonde transmission.

In January 1988 six "production" versions of the active clipper or blanker were installed in the ASWOC receiver building. At that time the ASWOC personnel seemed satisfied that they could live with the Digisonde.



In December ULCAR provided and installed a second AN/FMQ-12 remote terminal and modems in the ASWOC facility for Digisonde control of interference became objectionable. Both groups, the Canadian Forces of Daniel's Head and the ASWOC at the Navy Base, had personnel trained by D. F. Kitrosser in remote terminal operation (Appendix A).

## 5.0 IONOGRAM AUTOMATIC REAL TIME SCALER - PERFORMANCE ASSESSMENT

In June 1986 an experiment was conducted at Wallops Island, VA to determine the minimum transmitter power required for the acquisition of acceptable automatically processed ionogram data at a mid-latitude site [Haines, 1986]. Using the same TCi 613 antenna as deployed in Bermuda, the Wallops Island experiment showed that a transmit power of 170 Watts resulted in a mean absolute foF2 error of 0.17 MHz and a standard deviation of 0.42 MHz when compared to the values obtained from a transmit power of seven kilowatts.

The Engineering Specification for the Air Weather Service Digital Ionospheric Sounding System (SMALC (MMA) 84-012A, 1985) requires an overall accuracy of  $\pm 0.5$  MHz (in frequency) for 85% of all observations below 55° geomagnetic latitude.

The performance of the Automatic Real Time Ionogram Scaler with True Height (ARTIST) was investigated using 611 ionograms that were taken during the November 1987 test period. The 611 ionograms were scaled manually for foF2 using the URSI guidelines [Piggott and Rawer, 1972]. The ARTIST foF2 values were then compared with the manual scalings. More than 96% of the ARTIST foF2 values are within  $\pm 0.5$  MHz of the manual scalings. Figure 6 shows the distribution of ARTIST errors for the 611 low power Bermuda ionograms.

It is concluded that the low power Digisonde operation at Bermuda does not significantly affect the ability of ARTIST to automatically scale the resultant ionograms. However, interference levels in the high frequency band at Bermuda are low compared to many other locations. The lack of industry and broadcast services on

## Bermuda Low Power Digisonde Operation

Comparison of ARTIST and Manually Scaled foF2 Values  
611 cases were compared

$$\text{Delta} = | \text{fof2}(\text{Manual}) - \text{fof2}(\text{ARTIST}) |$$

> 96% of the ARTIST scaled foF2 values were within 0.5 MHz of the manually scaled values

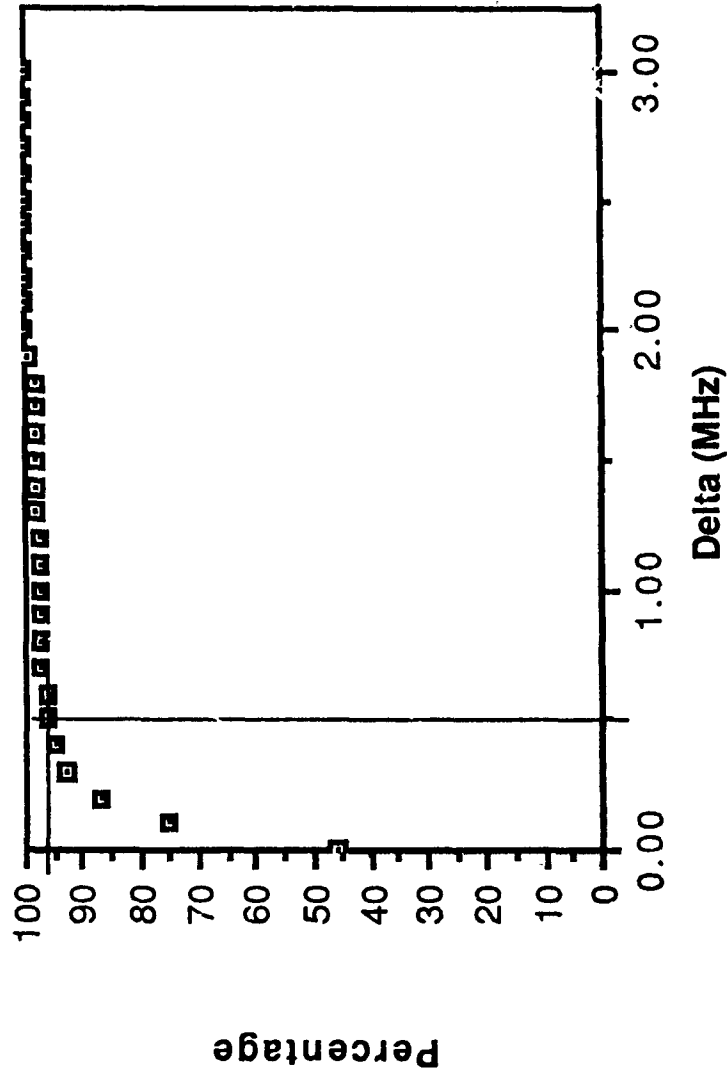

Figure 6. Comparison of ARTIST and Manually Scaled foF2 Values

Bermuda combined with the spatial separation of Bermuda from Europe and North America contribute to the low interference levels for most of the day. The 10 kilowatt capability of the Digisonde transmitter is often needed at other locations to achieve acceptable signal-to-noise ratios given the local and propagated interference levels found in Europe, urban areas of North America and the rim of the western Pacific.

An analysis of the impact of low power operation on the quality of ARTIST analysis during disturbed and absorption conditions should be undertaken. When the operation at extremely low power at Bermuda was the only way to get approval for transmission, a thorough analysis of the overall impact of low power operation on long term operations is necessary, before reduction in transmit power should be considered for other locations.

## 6.0 RECOMMENDATIONS FOR PERMANENT DEPLOYMENT

Two primary technical objectives have been achieved during the Bermuda Digisonde test program, i.e. a Digisonde can be operated in Bermuda at low power levels so as to not cause significant interference to other users of the HF band, and the automatic ionogram scaler (ARTIST) provides results that are consistent with previous ARTIST performance evaluations. It should be noted that interference levels, significantly higher than those found in Bermuda, may prevent successful low power Digisonde operation at other locations. Systematic analysis of ARTIST performance under a variety of geomagnetic conditions should be undertaken to assess the long term impact of low power transmissions.

Given that the Digisonde provides useful data and does not interfere with other users, it is recommended that a permanent installation be completed. The present siting is acceptable from the point-of-view of Digisonde performance. A permanent installation will require the following additional work:

- Guy wires across the trailer to prevent movement during high winds.
- Anchoring the seven receive antennas to the reservoir roof and the water catchment area to prevent movement during high winds.
- Securing the receive antenna cable runs in locations to minimize inadvertent damage by facility maintenance personnel.

It should be noted that the high moisture and salt content of the Bermuda environment will require frequent maintenance

(approximately quarterly) and probably repair to prevent corrosion from reducing Digisonde performance. Attention should be given to all antenna connections as these are subject to continual exposure to the moist, salty air.

## 7.0 REFERENCES

Haines, D. Mark, "Digisonde 256 RF Power Tests at Wallops Island, Test Evaluation Report," AFGL-TR-86-0185, ADA 173831, 1986.

Piggott, R. W. and K. Rawer, "U.R.S.I. Handbook of Ionogram Interpretation and Reduction," World Data Center A for Solar-Terrestrial Physics, Reports UAG-23 and UAG-23A, Boulder, CO, 1972.

Sacramento Air Logistics Center (MMA), Engineering Specification SM-ALC (MMA) 84-012A, 15 January 1985.

APPENDIX A

Digisonde Remote Terminal Operation

## REMOTE TERMINAL OPERATION

### To Shut Sounder Off:

Turn Power On

Automatically Dials X6346

After connection type

Alt 1 "1" is on right hand keypad  
Holt Alt key down while typing "1"

DGS appears in window at top center; if not, type Alt 1 again.

Typing "STOP" and entering with Return key stops sounder (if it's running) immediately.

### To Stop Sounder Automatic Operation:

Type "DIS Return," then "O = 0 Return" DIS <Return>  
O = 0 <Return>

The number under the letter O in the window at the upper left should change to 0.

Call Bangor OTH-B Radar Operations Center

### To Resume 1/2 Hourly Automatic Operation:

Type:

Alt-1 to enter DGS mode

DIS to get DISplay window

@ sign in lower left of window signifies sounder is not running.

O=B to get 1/2 hour ops.

To Run an Ionogram Manually:

Type:

Run A1 <Return>, while in ALT-1, DGS mode

Running ionogram and scaling takes about 4 minutes.

Hit Return Key twice to clear ERROR MESSAGE in upper left window or to rewrite upper left window.

"ALT X" toggle large window characters

"ALT S" 132 characters across for full ionogram width on screen

"ALT L" (default) 80 characters across

To Obtain Ionograms:

Turn Power On

Automatically dials X6346

After connection last ionogram is printed automatically, unless someone else has called sounder and taken it already. If latter is the case, request "Complete Last Ionogram" using the appropriate polling command.

Polling Commands      \$01 last 24 hours. foF2  
                             \$02 last 24 hours. foF1

\$03 last 24 hours. M(3000)  
\$0F AWS message  
\$1F Complete last ionogram

$M(3000) \times foF2 = MUF(3000)$

M-factor

Telephone Support  
University of Lowell  
(508) 458-2504

David F. Kitrosser  
Terence W. Bullett  
May Tang