

DTIC FILE COPY



Best Available Copy

 National Defence / Défense nationale



AD-A221 828

MODIFICATION OF A CAM FACILITY (U)

by

D. Hidson

20030211011

DTIC
ELECTE
MAY 24 1990
S E D
CO

DEFENCE RESEARCH ESTABLISHMENT OTTAWA
TECHNICAL NOTE 90-7

Canada

DISTRIBUTION STATEMENT A
Approved for public release;
Distribution Unlimited

March 1990
Ottawa

90 05 23 070



National Défense
Defence nationale

MODIFICATION OF A CAM FACILITY (U)

by

D. Hidson
Chemical Protection Section
Protective Sciences Division

DTIC
ELECTRIC
MAY 21 1990
S E D

DEFENCE RESEARCH ESTABLISHMENT OTTAWA
TECHNICAL NOTE 90-7

PCN
051LD11

DISTRIBUTION STATEMENT A
Approved for public release;
Distribution Unlimited

March 1990
Ottawa

ABSTRACT

A CAD/CAM system is described in which a Data General MV4000 computer serves as a hardware platform for Unigraphics software. A paper tape punch facility is replaced by a floppy disk file storage system. Commands for storing, editing and reading files on the floppy disk are described, and the file structure required for a Matsuura CNC machine and Fanuc controller are included. The device also replaces the tape reader on the CNC machine by means of a parallel port.

RÉSUMÉ

Un système CAO/FAO est décrit dans lequel un logiciel Unigraphics est utilisé via un ordinateur Data General MV4000. La bande perforée fut remplacée par un système de fichiers sur disques souples. Les commandes de stockage, d'édition et de lecture des fichiers sur disques souples sont présentés et la structure des fichiers pour une machine Matsuura CNC et un contrôleur Fanuc sont inclus. Le dispositif remplace aussi le lecteur de bande sur la machine CNC par le biais d'une connexion parallèle.



Accession For	
NTIS GRA&I	<input checked="" type="checkbox"/>
DTIC TAB	<input type="checkbox"/>
Unannounced	<input type="checkbox"/>
Justification	
By _____	
Distribution/	
Availability Codes	
Dist	Avail and/or Special
A-1	

EXECUTIVE SUMMARY

Modification of the computer-aided design and manufacturing facility at DREO is described. Paper-tape punching is replaced with data storage on diskettes and the method of setting up files for a Matsuura Computer Numerical Control (CNC) machine with a Funac controller is described. Gains in ease and speed of manufacturing result. Methods of expanding the applicability of this arrangement to any CNC machine/controller combination are shown.

TABLE OF CONTENTS

<u>TITLE</u>	<u>PAGE</u>
ABSTRACT/RÉSUMÉ	iii
EXECUTIVE SUMMARY	v
1.0 Introduction	1
2.0 System Changes	4
2.1 Procedure for Producing Punched Tape	4
2.2 Minifile Disc System	6
3.0 Summary	9
References	10
FIGURE 1 - Schematic of Hardware Layout	5
FIGURE 2 - Schematic of Machining File Generation Procedure	7
APPENDIX A - G and M Function Table	A-1

1.0 INTRODUCTION

CAD/CAM (or Computer-Aided Design and Manufacturing) is one of the computer technologies of the 1980s whose development and expansion have changed the face of engineering. Since digital computers first appeared in the 1940s advances in solid state physics have reduced the size of computing machines by many orders of magnitude and increased their speed of operation and capacity to store data accordingly.

The first device that could be called a modern computer was developed in 1946 by the U.S. Navy. This was ENIAC (the Electronic Numerical Integrator and Calculator). The technology was based on vacuum-tubes and was capable of multiplying two 10 digit numbers in 1/40th of a second (1). With the introduction of solid-state devices (transistors) in the early 1950s, this computation time had been reduced to 1/100,000th of a second. These new devices were physically far smaller than the vacuum-tubes they replaced, and produced far less waste heat, so that each gain in processing speed was matched by a reduction in size.

This process of miniaturization accelerated in the 1970s with the introduction of integrated circuitry. This technique consisted of vacuum-depositing many layers of semiconducting materials in patterns so that electronic circuits could be built up. By the 1980s, this technology had advanced to the point where millions of transistors and other devices could be contained on one chip.

In the early days of computing, instructions were written in machine language (long strings of binary digits), which was a specialized and difficult procedure. Programming was made considerably simpler with the introduction of symbolic code wherein certain English-like commands would stand for several instructions in machine language. The languages FOPTRAN and COBOL were developed in the 1950s and, although they are more than 30 years old, they have been considerably enhanced in recent years, and are still in widespread use today.

The development of interactive graphics began with project Sketchpad in the early 1960s at the Massachusetts Institute of Technology. Here, a cathode ray tube (CRT) was connected to a computer and data input was achieved by means of a light pen contacting the screen. Computer commands then took this information and constructed lines, circles, arcs and other geometric entities (2). Using these techniques an engineering designer can generate a display on the screen and a hard copy of the finished drawing.

Most of the early development of CAD (or computer-aided design) systems came from the large automotive and aerospace industries. Only those companies possessed sufficient capital for

the investment in large-scale computing facilities. Boeing, General Motors and McDonnell Douglas all produced CAD/CAM systems for engineering design. Only with the advent of high-performance chips and minicomputers did CAD/CAM become a viable option for the smaller engineering companies.

Interactive graphics had to reach a certain stage of sophistication before investment in such technology became attractive as far as the general marketplace was concerned. The very first computer-driven graphics display was operational as long ago as 1950 in MIT's Whirlwind I computer but had no interactive capability (3). In 1962 Ivan Sutherland of MIT published a Ph. D. thesis entitled "Sketchpad: A Man-Machine Graphical Communication System" marking the true beginning of interactive graphics (4). A computer graphics display consists essentially of a frame buffer, a digital memory that stores an image of the display controller that passes the information in the frame buffer to the screen (5). In order to prevent flicker, the image must be refreshed at least 30 times a second.

This was technically difficult to do until large-scale cheap memory became available in the early 1980s. With that technological barrier overcome, considerable effort was put into designing software to perform a wide variety of engineering tasks: electronic circuit board design, mechanical engineering, architecture and cartography among others. Hard-copy output may be generated by means of plotters that are also directly controlled by the computer. Algorithms were rapidly developed to generate curves (parabolas, hyperbolas, splines etc.) and surfaces. A comprehensive survey of the necessary geometry may be found in references (6) and (7).

For mechanical engineering, the need to automate the machining process generated radical new ideas on the shop floor. N/C, or numerical control, began in 1947 when J.C. Parsons of the Parsons Corporation used punched cards to drive a machine cutting helicopter rotor blades. In 1952, the Massachusetts Institute of Technology developed the first N/C milling machine, a modified Cincinnati Hydrotel, and the term "numerical control" was born(8). By 1962, the capabilities of N/C machines included accuracies of 0.001 inches per foot.

N/C machines today have become CNC (computer numerical control) machines. They have capabilities that allow three-, four- and five-axis movement enabling complex curvatures to be cut with accuracies approaching 0.0001 inch (0.00254 mm).

To perform such functions, these machines have to be programmed. A language was developed for exactly this purpose called APT (Automated Programming of Tools). This language consists of descriptors to label points, lines, arcs and some curves and instructions for the motion of the cutting tool which

is governed by the geometry of the part. These instructions are sent by the machine controller to the N/C machine. APT programs may be written by hand or generated by computer. Most modern CAD/CAM systems now have the capability to generate APT source code for complex geometry models. This APT code is still not of immediate use to a CNC machine as it has to be post-processed for a particular machine/controller combination. This process defines the degrees of freedom of the system, the number of axes required, the type of cutters, the spindle speed and a host of other parameters. Every CNC machine/controller combination has different post-processor requirements.

The information produced to drive the machine is finally punched on paper tape in ASCII format. This is then read into the machine's memory for execution.

The paper tape is relatively large, bulky and prone to error. Further, compared to magnetic disks and diskettes, the density of data stored is very low. Coupled with this is the parallel problem that the memories of CNC machines are very small and expensive to enlarge. To solve this, some device is required that stores vastly more information than paper tape, that can supply data steadily and indefinitely to the CNC machine, and is not prone to significant read error problems. This problem was approached with diskette technology.

The major defects in the paper tape technology to be surmounted were inadequate memory for anything but the simplest surfaces, bulk, error-prone punching and reading techniques, and lack of speed in transferring data to and from the computer and the CNC machine.

The CAD/CAM facility at DREO uses a Data General MV4000 Eclipse computer as a hardware platform for Unigraphics CAD/CAM software. This combination is used for a variety of purposes including the design of protective equipment and the modelling of anthropometric data. The anthropometric data is gathered with a view of developing a method of using computer-aided design systems to model the data and develop average shapes as a basis for future design purposes. Thus data would be gathered by some form of remote sensing such as a laser scan, assessed as digital data and, through a variety of software techniques, new shapes could be generated that would serve as the basis of a design process.

The computer-aided design system is capable of generating command files for computer-controlled numerical machines (CNC machines) to cut arbitrary shapes using three-, four- and five-axis machines. Data for simple, analytical shapes are relatively simple to represent by point-to-point data files of manageable length. When complex geometry is considered, meaning geometry of continuously varying curvatures, such as a human face, then the data files become very large. When this happens, it becomes

difficult to put these files on the paper tapes that are usually used as the data input for CNC machines.

2.0 SYSTEM CHANGES

The above problem can be solved by changing the paper tape data storage system to a floppy disc storage device. When the data is stored in this fashion, it occupies a fraction of the volume and may be transmitted at much higher rates to the CNC machine directly. Figure 1 shows a schematic of the CAD/CAM arrangement with a paper tape punch. The RS232 connections to the punch will support the CNC Minifile, a floppy disc substitute for the punch. The device is manufactured by Greco Systems, 37 Coogan Way, El Cajon, CA 92020.

2.1 PROCEDURE FOR PRODUCING PUNCHED TAPE

We begin with a surfaced model in Unigraphics. Enter the Manufacturing Module and execute the commands MILL, PARAMETER LINE. 'Parameter line' is a command that allows several surfaces to be joined together and treated as one as far as the machining processes are concerned. The surface gradients and edges have to match within a specified tolerance. This tolerance must not be set too tightly or no match will be possible. It is a quirk of the software that these may be set as low as one millionth of an inch (0.0000254 mm).

This mode of producing CNC cutter paths from surfaced models relies on the spline curve structure of the surface geometry as data input. Knowledge of how the part is to be manufactured is essential. It is easy to give the machine instructions that render it impossible to manufacture the part in reality. This knowledge must be incorporated with the information demanded of the tool path generation process: that is, tool dimensions which are essential for computing tool center offsets and the type of milling (zig-zag, or area etc.) requested by the designer or required by the part.

All this information is codified in the postprocessing sequence where the cutter location information is translated into point-to-point instructions for a particular CNC machine and controller combination. The process is illustrated in Figure 2.

When this process is completed, the information is ready to be punched to paper tape. This is done by means of a program 'XLATOR' resident on the AOS/VS operating system. XLATOR will punch tape in EIA or MCD code and in 7- or 8- bit formats. The data is then passed to the terminal @CON5 at 600 baud and punched on a FACIT 4070 tape punch.

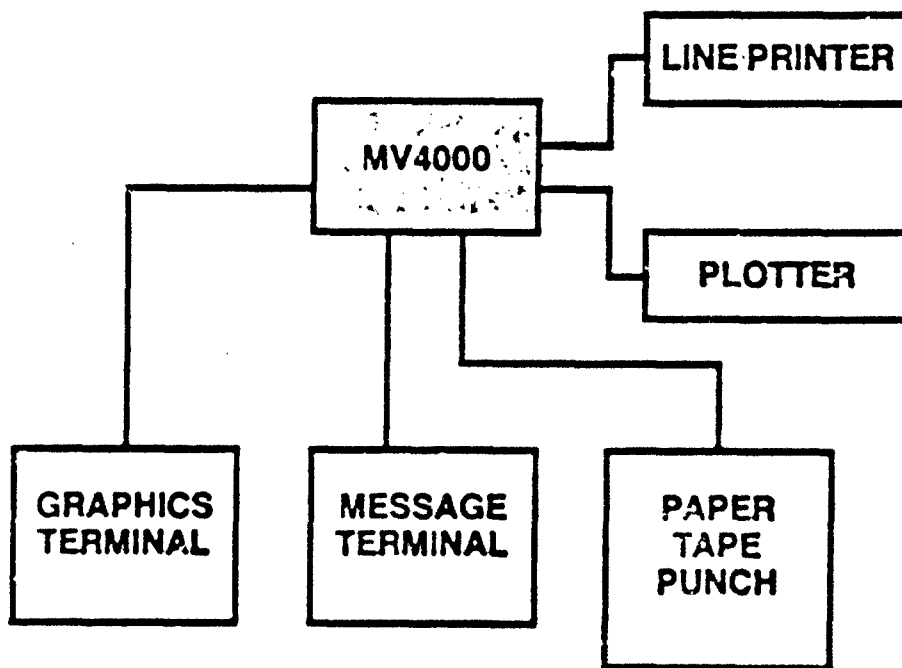

FIGURE 1: Schematic of Hardware Layout

The quantity of data that may be stored on a reel of paper tape is not great, especially if one is dealing with parts having complex geometry. A few hundred feet of tape that requires one inch for only twelve characters is inherently limited.

2.2 MINIFILE DISC SYSTEM

The minifile disc system allows the paper tape to be removed from the system. It enables the punch data to be stored on a floppy disc and to be fed into a CNC machine controller through a parallel port reader. The device consists basically of a disc drive which is IBM AT-compatible, two RS-232 ports, one parallel port, and a keyboard numeric pad for inserting commands to control the device.

The discs used by the system are double-sided floppy diskettes using a soft-sector format. They hold 360 KB of information which is equivalent to 3000 feet of paper tape. The system contains a command structure that enables disc formatting, file maintenance and some data editing to enable the shop floor CNC machine operator to correct minor errors.

The FACIT paper tape punch was disconnected and the Minifile connected to the same RS232 port (@CON5 in the Data General format). The data transmission speed was changed to 9600 baud. This could be performed by changing the set-up commands in the UP macro, executed at system start-up, or when required at the operator console. Either way the command CHAR/DEF/BAUD=9600 @CON5 resets the transmission speed at the requisite port where @CONn is the port descriptor.

The Minifile was prepared to accept the punch data in the following way. Channel 0 was selected for data input. Channels 0 and 1 represent the serial ports and channel 2 the parallel port. For the particular machine/controller combination (Matsura 1000V and Fanuc 6 controller) the commands entered were:

```
Select channel 0:      49# 0#
Set Text File type:   51# 1# (Enabled)
Line Feed output:    52# 1# (Enabled)
EIA Conversion:      53# 0# (Disabled)
LF to CR Conversion:  55# 1# (Enabled)
Set Switch Register:  80# 1010 0110 1000 1011#
Set Reader Speed:    82# 500# (Character speed)
Save Parameters      42# Wait for signal
```

Files can be named with numeric or letter characters eg. a file 101.TXT, if entered with the 2# command generates a numeric name or if entered with the 7# command generates a letter label. The file type command determines if the file created will be a binary or text file (with .BIN or .TXT as a suffix).

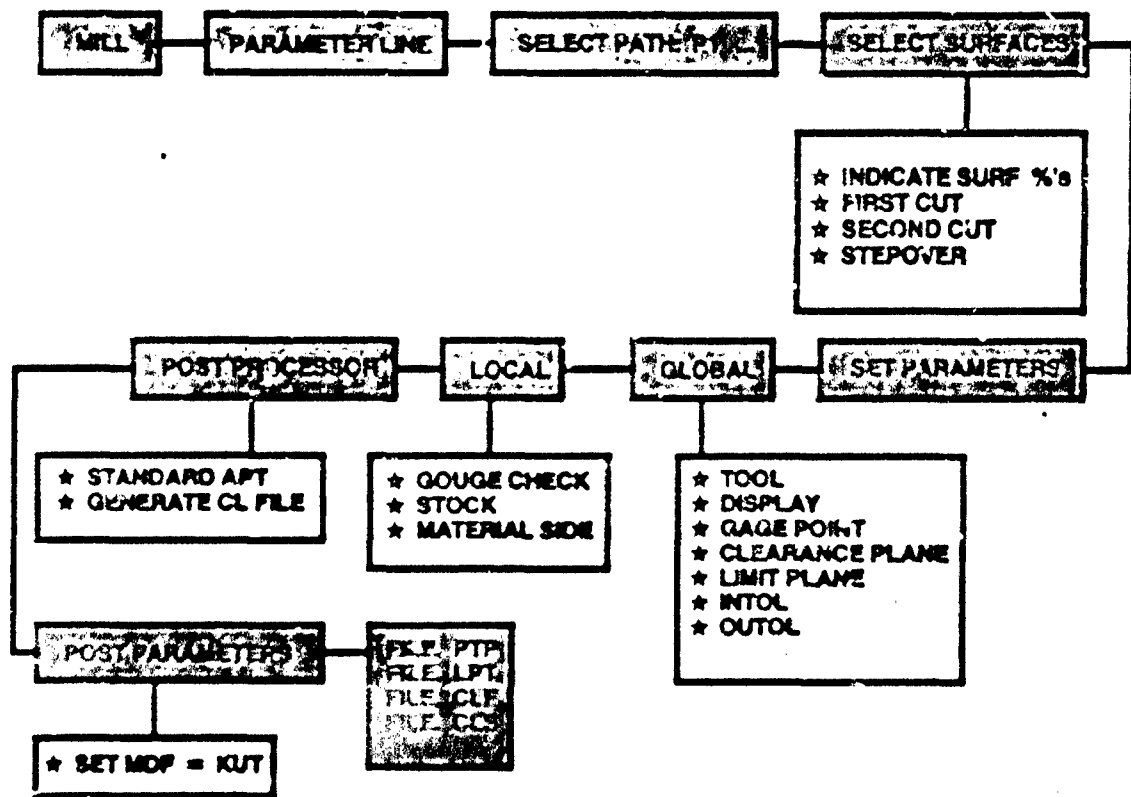

FIGURE 2: Schematic of Machining File Generation Procedure

The line feed output and the line feed to carriage return conversion (commands 52# and 55#) must be enabled to ensure both are transmitted when storing files on the diskette. If the correct combination is not present, the machine controller will not be able to read the files as separate records.

The EIA conversion (command 53#) is disabled as the XLATOR program generates data in this format. If the source were in ASCII, then the conversion would be enabled to ensure that the data were in EIA code when stored on the diskette. This is essential for readability by the controller.

When data is being downloaded on to the Minifile, that is, when it is in tape punch emulation mode, the 1# command is used to open and define the file; the data are downloaded by means of the XLATOR program to the diskette; and then the file closed using the 3# command. Command 4# will display the number of free blocks on the diskette at any time.

In order to reduce to a minimum the amount of editing required on the shop floor, the file headers and footers are inserted by means of the line editor in GRIP. This is done after the punch files (+.PTP suffix) have been produced and before they are downloaded on to the Minifile diskette. The header file inserted is as follows:

```
*****File: 1:MATSUURA.STR
%
00000<LF>
G00G17G20G22G40G49G54G64<LF>
G80G91G94G98M77<LF>
G28 Z0. M38<LF>
G28 X0. Y0. M48<LF>
M00<LF>
(TITLE OR COMMENTS)<LF>
M06 T<LF>
M03 ST<LF>
G90G00 G43 Z+2.0 H<LF>
X0.0Y0.0<LF>
```

The footer file inserted is as follows:

```
*****File: 1:MATSUURA.END
G90 G00 Z+3.0 M09<LF>
G80 G40 M05 G28 Z-2.0<LF>
M46<LF>
M30<LF>
```

The "<LF>" that ends each line, that is, the line feed character, must be inserted as four distinct characters so that the XLATOR tape punch software will correctly translate the end-of-line characters in the .PTP files before the file is downloaded to tape or diskette.

These files set up the machine parameters required for the work eg, G90 or 91 determines whether the motion will be absolute or incremental. M30 at the end denotes a rewind command. A description of the G-codes and M-codes for the Matsuura CNC machine and its Fanuc controller is given in Appendix A. This is included as some G-codes are universal and some are user-defined and some are global while others are local as far as the CNC machine controllers are concerned.

When the device is being used as a tape reader emulator, the parameters have to be reset, e.g. active channel (49#) must now reflect the use of the parallel port (2#). The 50-pin Telco-type connector is the physical interface that replaces the tape reader. The circuit card on the end performs some functions such as simulation of mechanical reader contacts. Some parameters have to be set at the Minifile control panel itself e.g. reader speed and signal timing. When the device is again transferred to be used as a tape punch emulator, these parameters have to be reset for serial port input etc.

3.0 SUMMARY

The Greco Systems CNC Minifile Tape Reader/Punch Emulator performs a valuable function of replacing the cumbersome paper tape technology with magnetic diskettes. Paper tape for CNC machines is bulky with many hundreds of feet of tape for relatively simple parts and slow to generate. Reliability of punched data at 1200 baud, the fastest for the FACIT punch, is not sufficient as too many errors are produced. This reduces the real maximum to 600 baud. Parts with 3-D geometry require thousands of feet of tape. The Minifile allows storage of 360 KB of data on a 5-1/4 inch diskette which may be read directly into a CNC machine controller at any rate desired. The parallel port allows emulation of a tape reader on the shop floor, simplifying and speeding up the preparation of files. XT- and AT- compatible Minifiles add to the device's utility.

REFERENCES

1. Krouse J.K., "What Every Engineer Should Know About Computer-Aided Design and computer-Aided Manufacturing", Marcel Dekker Inc., 1982, page 2.
2. Ibid, page 9.
3. Everitt, R.R., "The Whirlwind I Computer", Joint AIEE-IRE Conf., 1952, page 70.
4. Sutherland, I., "SKETCHPAD: A Man-Machine Graphical Communication System", MIT Lincoln Lab. Tech. Rep. May 1965.
5. Newman, W., Sproull, R.F., "Principles of Interactive Computer Graphics", McGraw-Hill, New York, 1979, page 7.
6. Faux, I.D., Pratt, M.J., "Computational Geometry for Design and Manufacture", Horwood, Chichester, U.K., 1985.
7. Qiulin, D., Davies, B.J., "Surface Engineering Geometry for Computer-Aided Design and Manufacture", Horwood, Chechester, U.K., 1987.
8. Arthur, R.D., Prentice, R.C., "Programming for Numerical Control Machines", McGraw-Hill Book Company, New York, 1978, page 2.

APPENDIX A

G-FUNCTION TABLE		
G-CODE	FUNCTION	BASIC/OPTION (B/O)
G00	Positioning (Rapid traverse)	B
G17	XY-plane selection	O
G20	Input in inches	O
G22	Stored stroke limit ON	O
G40	Cutter compensation cancel	B
G49	Tool length offset cancel	O
G54	Work coordinate system 1 select	O
G64	Cutting mode	B
G80	Canned cycle cancel	O
G91	Incremental programming	B
G94	Per minute feed	B
G98	Return to initial point in canned cycle	O
G28	Return to reference point	O
G90	Absolute programming	B
G43	Tool length offset & direction	O
M-FUNCTION TABLE		
M-CODE	FUNCTION	
M00	Programmed stop	
M03	Spindle CW rotation	
M05	Spindle stop	
M06	Tool change	
M09	Oil mist...coolant OFF	
M30	End of tape	
M38	Spindle override effective	
M46	Tool evacuation from spindle	
M48	M49 cancel	

SECURITY CLASSIFICATION OF FORM
(highest classification of Title, Abstract, Keywords)

DOCUMENT CONTROL DATA

(Security classification of title, body of abstract and indexing annotation must be entered when the overall document is classified)

1. ORIGINATOR (the name and address of the organization preparing the document. Organizations for whom the document was prepared, e.g. Establishment sponsoring a contractor's report, or tasking agency, are entered in section 8.) DEFENCE RESEARCH ESTABLISHMENT OTTAWA National Defence Ottawa, Ontario K1A 0Z4		2. SECURITY CLASSIFICATION (overall security classification of the document including special warning terms if applicable) UNCLASSIFIED	
3. TITLE (the complete document title as indicated on the title page. Its classification should be indicated by the appropriate abbreviation (S,C or U) in parentheses after the title.) MODIFICATION OF A CAM FACILITY (U)			
4. AUTHORS (last name, first name, middle initial) HIDSON, David			
5. DATE OF PUBLICATION (month and year of publication of document) MARCH 1990	6a. NO. OF PAGES (total containing information. Include Annexes, Appendices, etc.) 17	6b. NO. OF REFS (total cited in document) 8	
7. DESCRIPTIVE NOTES (the category of the document, e.g. technical report, technical note or memorandum. If appropriate, enter the type of report, e.g. interim, progress, summary, annual or final. Give the inclusive dates when a specific reporting period is covered.) TECHNICAL NOTE			
8. SPONSORING ACTIVITY (the name of the department project office or laboratory sponsoring the research and development. Include the address.) DEFENCE RESEARCH ESTABLISHMENT OTTAWA National Defence Ottawa, Ontario K1A 0Z4			
9a. PROJECT OR GRANT NO. (if appropriate, the applicable research and development project or grant number under which the document was written. Please specify whether project or grant) 051LD		9b. CONTRACT NO. (if appropriate, the applicable number under which the document was written)	
10a. ORIGINATOR'S DOCUMENT NUMBER (the official document number by which the document is identified by the originating activity. This number must be unique to this document.) DREO TECHNICAL NOTE NO. 90-7		10b. OTHER DOCUMENT NOS. (Any other numbers which may be assigned this document either by the originator or by the sponsor)	
11. DOCUMENT AVAILABILITY (any limitations on further dissemination of the document, other than those imposed by security classification) <input checked="" type="checkbox"/> Unlimited distribution <input type="checkbox"/> Distribution limited to defence departments and defence contractors; further distribution only as approved <input type="checkbox"/> Distribution limited to defence departments and Canadian defence contractors; further distribution only as approved <input type="checkbox"/> Distribution limited to government departments and agencies; further distribution only as approved <input type="checkbox"/> Distribution limited to defence departments; further distribution only as approved <input type="checkbox"/> Other (please specify):			
12. DOCUMENT ANNOUNCEMENT (any limitation to the bibliographic announcement of this document. This will normally correspond to the Document Availability (11). However, where further distribution (beyond the audience specified in 11) is possible, a wider announcement audience may be selected)			

13. ABSTRACT (a brief and factual summary of the document. It may also appear elsewhere in the body of the document itself. It is highly desirable that the abstract of classified documents be unclassified. Each paragraph of the abstract shall begin with an indication of the security classification of the information in the paragraph (unless the document itself is unclassified) represented as (S), (C), or (U). It is not necessary to include here abstracts in both official languages unless the text is bilingual).

A CAD/CAM system is described in which a Data General MV4000 computer serves as a hardware platform for Unigraphics software.

A paper tape punch facility is replaced by a floppy disk file storage system. Commands for storing, editing and reading files on the floppy disk are described, and the file structure required for a Matsuura CNC machine and Fanuc controller are included. The device also replaces the tape reader on the CNC machine by means of a parallel port.

Handwritten notes:
... (K.R.)
7

14. KEYWORDS, DESCRIPTORS or IDENTIFIERS (technically meaningful terms or short phrases that characterize a document and could be helpful in cataloguing the document. They should be selected so that no security classification is required. Identifiers, such as equipment model designation, trade name, military project code name, geographic location may also be included. If possible keywords should be selected from a published thesaurus, e.g. Thesaurus of Engineering and Scientific Terms (TEST) and that thesaurus-identified. If it is not possible to select indexing terms which are Unclassified, the classification of each should be indicated as with the title.)

CAD/CAM
COMPUTER-AIDED MACHINING
CNC CONTROLLERS
DISK STORAGE