

**Integrated Radiometric Profiler
for Atmospheric Humidity and Temperature Measurements**

Final Scientific Report

AFOSR-85-0067

27 April 1990

**Dennis W. Thomson
Department of Meteorology
Pennsylvania State University
University Park, PA 16802**

**Approved for public release ;
distribution unlimited.**

Abstract

A 9 channel, integrated radiometer for recording multi-frequency sky brightness temperatures from which atmospheric integrated water, and water vapor and temperature profiles may be estimated has been designed, constructed and field-tested. The radiometer includes 3 water-dependent (22.25, 23.9, 31.45 GHz) and 6 oxygen-dependent (50.5, 53.0, 53.6, 54.89, 58.64, 61.03 GHz) frequencies. The radiometer includes 4 Dicke-type subsystems of 2, 1, 3 and 3 multiplexed frequencies each. Control and signal processing functions are accomplished using 8 digital signal processors, 2 per subsystem, which are in turn controlled by an 80286-equipped host computer. The basic radiometer package, exclusive of the host computer and multichannel signal processing chassis, is about 1/2 x 1/2 x 1 m and is designed for airborne and shipboard (antenna pedestal) mounting as well as ground-based overland operation. All system, antenna pointing control, and signal processing functions are handled through the host computer. The radiometer may be readily used in combination with wind profilers, ceilometer, sodar and other measurement systems as are useful for improving the precision and spatial resolution of inverted water and temperature profiles.



Accession For	
NTIS CRA&I	<input checked="" type="checkbox"/>
DTIC TAB	<input type="checkbox"/>
Unannounced	<input type="checkbox"/>
Justification	
By	
Distribution/	
Availability Codes	
Dist	Avail and/or Special
A-1	

Completed Project Summary

TITLE: Profilers for Remote Measurements of Atmospheric Winds, Temperature and Water Vapor and Liquid

PRINCIPLE INVESTIGATOR: Dennis W. Thomson
Department of Meteorology
Penn State University
University Park, PA 16802

INCLUSIVE DATES: 10/1/84 - 10/14/87

CONTRACT/GRANT NUMBER: AFOSR-85-0067

COSTS AND FY SOURCE: \$190,000, FY85

SENIOR RESEARCH PERSONNEL: None

JUNIOR RESEARCH PERSONNEL: None

PUBLICATIONS:

New perspectives on Atmospheric Structure and Dynamics", D.W. Thomson, Earth and Min Sci, 57, Vol. 1, pgs. 1-6 (1987/88).

"Development of a Multi-frequency Microwave Radiometer for the Measurement of Atmospheric Water Vapor and Temperature Profiles", C.A. Wassenberg, M.S. Thesis, Dept. of Elec. and Comp. Eng., Univ. of Arizona, Tucson, AZ (1989).

"Automatic Control and Data Analysis of a Multi-channel Millimeter Wave Radiometer", D.A. Zielinskie, M.S. Thesis, Dept. of Elec. and Comp. Eng., Univ. of Arizona, Tucson, AZ (1988).

ABSTRACT OF OBJECTIVES AND ACCOMPLISHMENTS:

The purpose of this DoD-URIP grant was to provide partial funding for the design, construction and field testing of a state-of-the-art multichannel radiometer to be used for atmospheric temperature and water profiling. The completed radiometer was then to be combined with earlier constructed VHF and UHF Doppler wind profiler systems for the purpose of completing the first university-located, integrated remote sensing system facility

in the U.S. (Thomson, 1987/88). Project goals were accomplished (as of Sept. 1990). Performance of the radiometer system has met or exceeded all technical specifications.

Completion of this sophisticated instrumentation system was an extended and difficult task. Factors which greatly complicated and compromised timely progress included the following.

- 1) This project was undertaken with the understanding that funding granted by AFOSR was a partial, albeit the major, contribution towards system hardware costs. Although the university promptly fulfilled all of its financial obligations to share purchase costs of various hardware components, it could not provide the necessary laboratory space to perform assembly and testing of the integrated subsystems. Consequently, it was necessary for much of the work to be completed externally, with industrial cooperation and, via informal agreements, at another university. General design work on the radiometer was completed in 1986 while the author was assigned to the Naval Postgraduate School. The major portion of the subsequent detailed digital system engineering and construction of the prototype system was performed at the Univ. of Arizona by C.A. Wassenberg and D.A. Zielinski under the guidance of Prof. J.A. Reagan in the Department of Electrical and Computer Engineering. Machine shop fabrication of mechanical subsystems was completed at Penn State with external support provided by the Office of Naval Research. Extensive testing and evaluation of the system hardware and development of the necessary mathematical signal inversion codes is the focus of the Ph.D. dissertation research (in progress) by Y. Han in the Dept. of Meteorology at Penn State.

- 2) This project was nearly catastrophically truncated when the final \$115,000 which had been contracted for the three phase systems development project were not allocated. Fortunately replacement funding was arranged in 1986-87 through the Office of Naval Research to cover the outstanding deficit so that the final essential components of the integrated system could be purchased.

- 3) Delivery by industry of critical components and subsystems with specified 90 to 180 day delivery schedules were as much as 3 to 8 months late. Purchasing procedures of some critical components were also complicated and delayed as a consequence of contradictory, and believed partially fictitious, performance claims made by one potential supplier of the required microwave components.

In spite of the above considerable difficulties, the integrated radiometer system, as was originally proposed, has been completed and, as indicated, is operating with performance that meets and/or exceeds all of the originally defined technical design specifications. The unit cost of the completed remote sensing systems, including the Doppler wind and radiometric profilers in the Penn State facility has been estimated to be about 20 to 25% of the current market value for some radiometers which have since recently become commercially available as "turnkey" systems.

The first summary article discussing the capabilities of the combined remote sensing systems constructed with financial assistance for this AFOSR grant is the above-referenced one by

Thomson (1987/88), a copy of which is attached as Appendix A. A second is in preparation for submission to the J. of Atmospheric and Oceanic Technology.

Use of and interest, nationally and internationally, in the Doppler wind profiler and radiometric instrumentation facilities for field measurement programs sited at the University continues to grow. One of the VHF Doppler wind profiling systems has been operated almost continuously since being installed in 1985. The transportable UHF profiler has been used for national experiments in Alabama (MIST/SPACE), California (FIRE), Arizona (Ariz. Monsoon), Massachusetts (ERICA) and New York (LOWS-I) as well as, whenever possible, at Penn State for a variety of physical meteorology and radar propagation studies. Plans are now in progress for one or more of the wind profilers and the radiometer to be deployed in the western Pacific for typhoon studies (TCM-90) and in the Azores for the next phase (ASTEX) of the ISCCP (International Satellite Cloud Climatology Project) study program. Upon completion of the current test and evaluation studies, the integrated radiometer system is also scheduled for additional, NASA-sponsored intercomparison studies at Wallops Island, VA.

Appendix 1

EARTH AND MINERAL SCIENCES

THE PENNSYLVANIA STATE UNIVERSITY, COLLEGE OF EARTH AND MINERAL SCIENCES, UNIVERSITY PARK, PENNSYLVANIA

New Perspectives on Atmospheric Structure and Dynamics

DENNIS W. THOMSON
Professor of Meteorology

Penn State is the academic leader in the development and application of ground-based profiling systems that are revolutionizing atmospheric observation and data collection.

Natural phenomena of interest to meteorologists range in size from atomic to global scales, and the associated time scales may range from the fraction of a second required for the emission or absorption of radiation to the billions of years over which Earth's atmosphere has evolved. As a result, compiling observational databases suitable for studying diverse atmospheric phenomena has always been a challenging problem.

In practice, however, it turns out that the difficulties are not scale-dependent, that is limited to either very short nuclear or long geological time scales, but instead are often caused by the intermittent nature of the observations. The database required to interpret or predict day-to-day changes in the weather, for example, has never been adequate. For comparison, suppose that you needed to describe the lifetime physiological development of a person. It would be a difficult task if the only information available to you consisted of snapshots and x-rays of a body at ages 1, 37, and 74, plus similar data from a group of different individuals at different ages. In every case, the time elapsed between measurements would be so long that significant developmental changes would have occurred between them. That, in effect, is the nature of the observational problem that has frustrated meteorologists for more than fifty years.

Synchronously every twelve hours, weather services throughout the world launch expendable weather balloons to gather measurements of atmospheric wind, temperature, and humidity profiles. Yet between these conventional measurements, large convective storms can begin, grow, mature, and dissipate. Today, it is probably the limitations resulting from this 12-hour observational interval rather than the availability of bigger, faster or more computers that create the greatest obstacle to significant improvements in weather analysis and prediction.

For about a decade, a quiet technological revolution in meteorological measurements has been in progress. During this time, dramatically improved ground-based remote sensing profiling systems have been developed. These systems can provide the long-needed continuous measurements that allow us to monitor the state and evolution of the constantly changing atmosphere. Appropriate processing of the profiler measurements also allows us to monitor process variables, such as the fluxes of momentum, thermal energy, and moisture. In short, the measurements obtained with these pro-

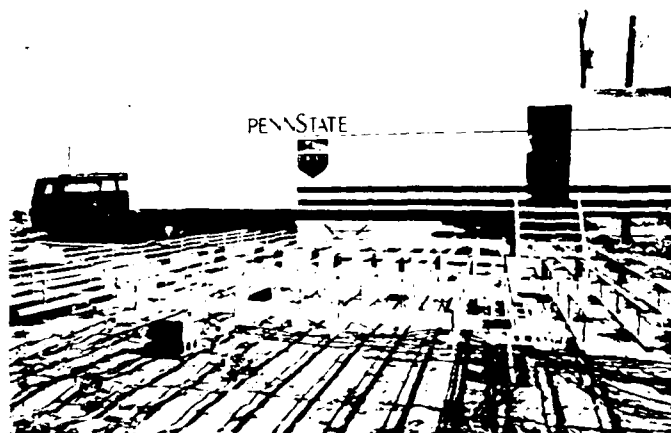

Figure 1. One of the Co-Co phased-array antennas and the 40-foot "portable" instrumentation trailer for the 404-MHz UHF wind profiler.

filers are so enhancing our understanding of atmospheric structure and dynamic processes that long-standing problems regarding the nature of atmospheric motions and the evolution of storms are being re-examined, other problems are being redefined, and totally new areas for research are being opened.

The Penn State Role

Penn State is currently, both nationally and internationally, the academic leader in the development and application of ground-based profiling systems. For the past five years, the Department of Meteorology has been designing, constructing, and testing a variety of profiling systems. Valued in excess of \$2.5 million, these systems are now providing unique continuous observations that are the envy of the atmospheric sciences research and teaching communities. Penn State is the first university in the world to have profiling radars for continuously measuring atmospheric winds and turbulence. The Department of Meteorology will soon be the first in the world to have a comprehensive set of microwave and millimeter wave radiometers for continuously monitoring tropospheric temperatures and humidity profiles. In addition, a special mm-wave Doppler radar operating at 94 GHz is under construction and soon will be providing measurements of the velocities of tiny cloud water drops. Only one other radar of this type exists in the world. Other equipment includes the unique microwave radiometer, the 23 GHz maser-based system, which has been operated jointly with the Department of Electrical Engineering since 1984 to provide stratospheric and mesospheric measurements.

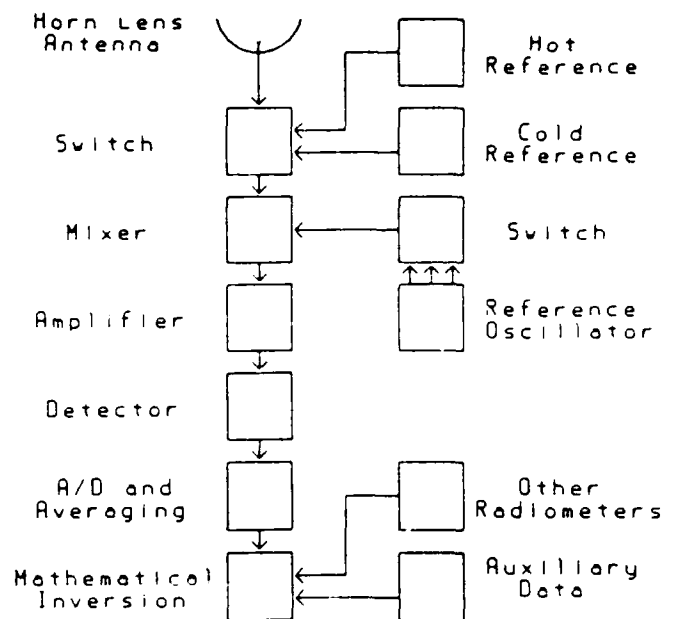
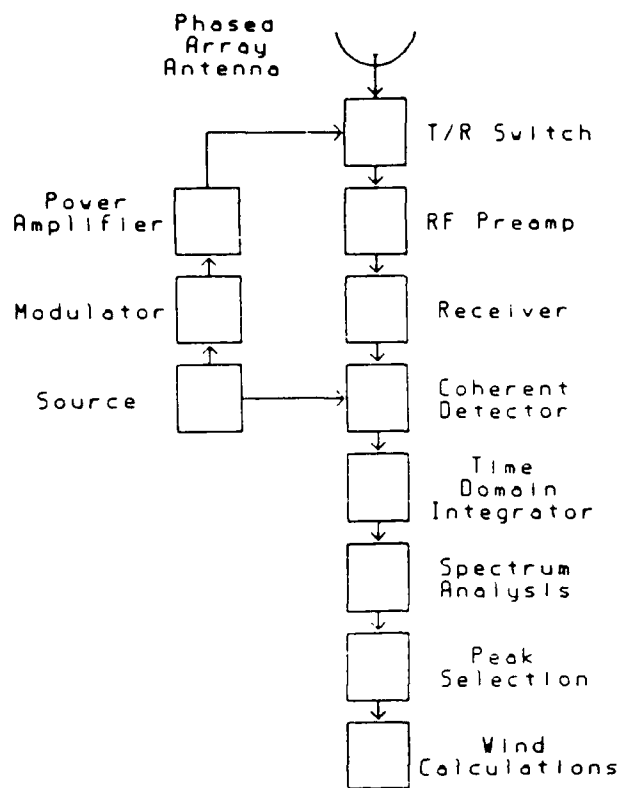

Figure 2. Left: Generic system block diagram for active radar-type remote sensing systems. Acoustic systems do not include the time domain integrator.

Figure 3. Above: Generic system block diagram for passive remote sensing systems, such as radiometers used for humidity and temperature profiling.

The primary focus of the profiler research programs at Penn State is meteorological applications, not engineering research and development. Thus, as far as possible, we have purchased the electronics modules and computers required to assemble each of the systems discussed in this article. When we began constructing the various profilers in 1982, none were available commercially. It was not until 1985 that we were able to simply purchase a complete profiler, a sodar, that would meet our scientific requirements. That sodar, and two subsequent ones, were built by EMS graduate Dr. K. Underwood, now at XonTech, Inc. The construction of wind profilers at Penn State proceeded essentially in parallel with the design and construction of systems which are now also commercially available. The transmitters, receivers, and antennas, built for us by Tycho Technology, were basically prototype components for the profilers they are now building for customers such as NASA Kennedy Space Flight Center and other universities. Since the commitment to develop a commercial system had been made earlier by Tycho, we were able to acquire state-of-the-art instrumentation without incurring major research and development costs. It is also worth commenting that both Tycho and NASA are employers of our new EMS "profiler" graduates. Other new employers of our graduates are the groups in NOAA's Wave Propagation Laboratory (WPL) which, like Penn State are doing basic research in profiler development and application. Many of the modules in Penn State systems were modeled after WPL prototypes, and their outstanding assistance was essential to the success of our program.

The emphasis in this article is on the diversity of the different profilers. Some of the ongoing research involves use of data obtained with single systems or with combinations of data from different co-located systems. However, most of the meteorological problems of interest need measurements from several locations or a network of systems, or require that the systems be deployed where the meteorological phenomena of interest occur. Great interest exists, for example, in the characteristics of both marine and tropical phenomena.

Table 1 summarizes the locations of the permanent systems and the places where the portable VHF and sodar systems have been used to date. The three permanent VHF profilers form a triangle that covers a large part of central and western Pennsylvania; two profilers are in operation and the installation of a third is in progress. The 50 x 50 m antenna at each site has about 600 supports

and 9 km of wire. The other wind and radiometric profilers can be transported anywhere by truck or ship to carry out diverse field measurement programs. For the UHF profiler, the 8 x 40 ft ship container shown in Figure 1 has been rebuilt into a portable laboratory. The phased-array sodar antennas are all mounted on 8 x 15 ft trailers.

Ground-Based Systems

While satellite-borne camera and instrumentation systems are unique in their capacity to provide global coverage, stationary ground-based remote sensing systems have certain important advantages over their satellite counterparts. Unlike satellite instruments, ground-based systems need not be limited by such considerations as size, weight, power consumption, or needs for human servicing. Thus they can be relatively far more sophisticated than satellite-borne systems. In most cases, the greater sophistication in ground-based systems results in the output of quantitative rather than qualitative observations. Satellite images, for example, often require visual interpretation or elaborate computer processing.

Profilers are the new generation of automated, ground-based remote sensing systems that can provide continuous quantitative measurements of atmospheric winds and state variables. Doppler radars operating in the VHF and UHF radiobands are used for measuring profiles of wind speed and direction, turbulence, and the refractive index profiles. Radiometers operating at frequencies ranging from 20 to 32 and about 90 GHz are used for monitoring water in the atmosphere. Depending upon how a particular

Table 1. Penn State Doppler Wind Profilers: Permanent sites and locations of use

Permanent VHF Sites	Portable UHF	Portable Sodars
I, McAlevy's Fort, PA	Rock Springs, PA	I, Rock Springs & Huntsville, AL
II, Crown, PA	Huntsville, AL	II, Aiken, SC & Three-Mile Is., PA
III, Laurel Mts., PA	San Nicolas Is., CA & Tucson, AZ	III, San Nicolas Is. & Monterey, CA

radiometer is configured and operated, it is possible to differentiate between water in the vapor, liquid, and ice phases. Electronically similar radiometers operating at frequencies ranging from 50 to 62 GHz provide the data from which atmospheric temperature profiles can be inferred.

Profilers are only one of many types of remote sensing systems that are used for atmospheric measurements. Laser-based optical systems, for example, are used for aerosol studies and monitoring cloud base heights. Scintillometers, which are essentially specially instrumented telescopes, provide continuous records of the transmission quality (designated "seeing") for earth-space optical propagation paths. It should also be noted that, since their initial development following World War II, conventional meteorological radars operating at frequencies from 5 to 15 GHz have been used throughout the world for determining the structure and motion of precipitating storms. However, for nearly 20 years most of the operational radars used by various national weather services have been technological dinosaurs. Many of these systems were designed in the 1950s and constructed in the 1960s, long before integrated circuits and high performance compact computing systems were available. It was not until late fall of 1987 that the U.S. Weather Service was finally able to let contracts amounting to \$450 million for building and installing 195 state-of-the-art precipitation-sensing Doppler radars. These radars have long been needed for monitoring life-threatening storms and other hazards to people and aviation.

Some Remote Sensing Basics

Remote sensing systems, such as radars, are defined as *active* because one component of the system is a signal source or transmitter. Figure 2. Other remote sensors, such as radiometers, are *passive* because for these systems the atmosphere itself serves as the source of the measured signals. Figure 3. Most atmospheric remote sensing systems are electromagnetic but a few like the sodar, which is the atmospheric analog of underwater sonar, use acoustic signals. The wavelengths used, ranging from visible optical to VHF radio, encompass more than seven decades.

The atmosphere is a variable, inhomogeneous, and dirty gas. The particles in it can range more than six decades in size, from condensation nuclei, smaller than 10⁻⁶ m, to hailstones greater than 10⁻¹ m. The characteristics of propagating electromagnetic (EM) or acoustic (AC) radiation, natural or artificial, depend critically upon the spatial and temporal refractive index variations of the gas itself, as well as on the interaction of the radiation with the various scattering and absorbing particles. The science of remote sensing is essentially the art of processing measured EM and AC signals in such a way that the physical properties of the propagation medium can be inferred.

The radiation-atmosphere interactions fundamental to the operation of various profilers include the following:

- 1) Refractive index variations at EM radio frequencies associated with normal turbulent temperature, and moisture fluctuations typically range from about 0.1 to 5 ppm. In comparison, propagating AC waves are about a million-fold more sensitive to the same variations. These small refractive index variations, defined in terms of the structure parameter, are quite enough to scatter measurable EM or AC energy. Scattering by the inhomogeneities is most effective at the spatial scale corresponding to $\lambda/2$, Table 2. This scattering process may be interpreted in analogy to the Bragg angle in X-ray diffraction.
- 2) Particles that typically have refractive indices at visible wavelengths ranging from 1.33 (water) to 1.54 (SiO₂) are by comparison far more efficient scatterers. The nature of this particle scattering depends critically on many factors. One of the most important is the ratio of the particle size to wavelength.
- 3) EM or AC energy scattered by moving atmospheric gas or particles will be Doppler shifted in frequency in proportion to the scatterer's velocity. The Doppler shift also depends on the direction of the scatterer's motion with respect to the pointing angles of the system's antennas.
- 4) In the troposphere and stratosphere, the maximum black body radiation by atmospheric gases is in the infrared. But significant

Table 2. System and Signal Types and Derived Atmospheric Variables

SYSTEM	TYPE	FREQUENCY	$\lambda/2$	SIGNAL SOURCE OR SCATTERING	RECEIVED SIGNAL	DERIVED ATMOSPHERIC VARIABLES
VHF wind profiler	active	50 MHz	3m	refractive inhomogeneities	Doppler shift return power	wind speed and direction refractive structure parameter $\lambda/2$ 3m
UHF wind profiler	active	404 MHz	37cm	refractive inhomogeneities	Doppler shift return power	wind speed and direction refractive structure parameter $\lambda/2$ 37cm
Doppler sodar acoustic	active	1600 Hz	11cm	temperature inhomogeneities	Doppler shift return power	wind speed and direction temperature structure parameter $\lambda/2$ 11cm
Conventional radar (incl Doppler)	active	3 to 10 GHz	10 cm to 3 cm	Raleigh scatter from precipitation	Doppler shift return power	precipitation and wind velocities precipitation type and rain rate
H ₂ O radiometer	passive	20 to 32 GHz	1.5 cm to 9 mm	H ₂ O absorption of atmospheric radiation	power or brightness temperature	H ₂ O profile
O ₂ radiometer	passive	50 to 62 GHz	6 mm to 5 mm	O ₂ absorption of atmospheric radiation	power or brightness temperature	temperature profile
H ₂ O radiometer	passive	30 GHz	33 mm	H ₂ O absorption of atmospheric radiation	power or brightness temperature	H ₂ O profile
Doppler cloud radar	active	34 GHz	32 mm	Raleigh scatter from cloud drops	Doppler shift return power	cloud drop velocities cloud water

emission and absorption also occur at microwave and mm wave frequencies. With appropriate sampling and measurement of the brightness temperature at selected frequencies, these signals can be processed to infer profiles of atmospheric humidity and temperature.

5) Atmospheric absorption of AC radiation in the range of usable frequencies is strong, and thus fundamentally limits to about 800 to 8000 Hz the usable range of AC systems such as the sodars. Absorption is also important at EM frequencies above about 30 GHz.

Table 2 summarizes a variety of remote sensors by system type and wavelength, and the nature of the received signal which must be processed to extract information regarding the particular atmospheric variables of interest. Thus wind profiles are measured by appropriate processing of turbulence or particle-scattered and Doppler-shifted signals. Depending on the wavelength, the scattering will be from turbulence-associated refractive inhomogeneities or the result of scattering by precipitation or cloud drops. Determination of temperature and humidity profiles involves processing of received atmospherically-emitted radiation in selected H₂O and O₂ absorption bands. Mathematically, the processing of radar and radiometer signals differs greatly.

Profiler Subsystems and Configurations

Figures 2 and 3 illustrate schematically the basic components of active radar (or sodar) and passive radiometric profilers. Much of the

engineering effort and cost in the design and construction of the radar-type systems is associated with meeting the performance specifications required for phase-coherent operation. Frequency or phase instabilities in the source, or anywhere else in the processing of the transmitted and received signals, will degrade the quality of the calculated spectrum of the Doppler-shifted received signal, and hence also degrade the accuracy and precision of the derived winds.

The final design and operation of any profiling system is a seemingly endless list of trade-offs. To increase the effective power and limit the size of the sensed volume, the antennas need to be as large as possible. 50 × 50 m for each VHF profiler, but there are practical and economic limits to antenna size. Time domain integration, i.e. the prespectral multipulse averaging, needs to be as long as possible to increase the ratio of signal to noise. At the same time, it cannot be so long that the atmosphere in the sampled antenna volume changes significantly during the averaging period. Usually, increasing the pulse length will improve signal-to-noise, but doing so will also degrade the spatial resolution. The use of short pulses that improve spatial resolution will degrade the spectral or velocity resolution. Thus, figures such as those quoted in Table 2 represent compromises among the many parameters which must be considered in designing a particular system.

Although radiometric systems do not need to be phase-coherent, their design and operation present a distinctly different set of technical and construction problems. The cost of individual components, particularly for operating frequencies above 40 GHz, is exceedingly high. Components such as mixers, oscillators, and switches are individually machined gold-plated blocks of brass in which the dimensional tolerances are such that the milling machine tools have diameters finer than a typical human hair (< 0.015 in.). The installed electronic components, some as small as 10 μm, can be seen only with a binocular microscope. Once constructed in a cleanroom environment, the radiometer subsystems must be mounted in specially fabricated environmentally controlled housings. Penn State's integrated radiometer actually includes four radiometer subsystems of the type shown in Figure 3.

Another difficult fabrication problem for the radiometers is the optical-grade alignment required of the four neighboring antennas. Insofar as possible, the signals received at the nine different frequencies must originate from the same volume of atmosphere. Misalignment of the antennas such that a cumulus cloud might be in the beam of one radiometer receiver but not in another would result in a database which could not possibly be mathematically inverted.

The Penn State radiometer is the most advanced system of its type in the world. Presently the Meteorology Department has neither the personnel nor facilities to complete the engineering, fabrication and testing of such an instrument. That part of the development program has been performed outstandingly by Prof. J.A. Reagan and his graduate students C. Wassenberg and D. Zielinski in Electrical Engineering at the University of Arizona.

Unlike conventional radars which have movable antennas, profiler antennas are usually stationary. But wind is a vector variable with *u*, *v* (or speed and azimuthal direction) and *w* (vertical) components. Hence, the VHF and UHF radar and sodar Doppler profilers must all have three antenna beams. The basic signals are the Doppler shifts corresponding to motions along the radial or pointing axis of each antenna beam. Normally, one beam is pointed vertically for *w* and the two additional beams are pointed orthogonally to one another and 15° and 30° off the zenith. By applying the appropriate 3-D coordinate transformations to the signals derived from each antenna beam, the *u*, *v*, and *w* components of the wind can all be determined.

Antennas for both the EM and AC profiling systems are usually of the phased-array type; that is, the various antenna beams are generated and pointed by changing the relative phase of the signals between individual antenna elements. Penn State's VHF and UHF wind profilers use Co-Co (Colinear-Coaxial) antennas. Indeed, the 404.37 MHz Co-Co in the UHF profiler was the first of its type in the world. Elements in the phased-array antenna for the Doppler sodars are high power acoustic transducers (25 in total) that are con-

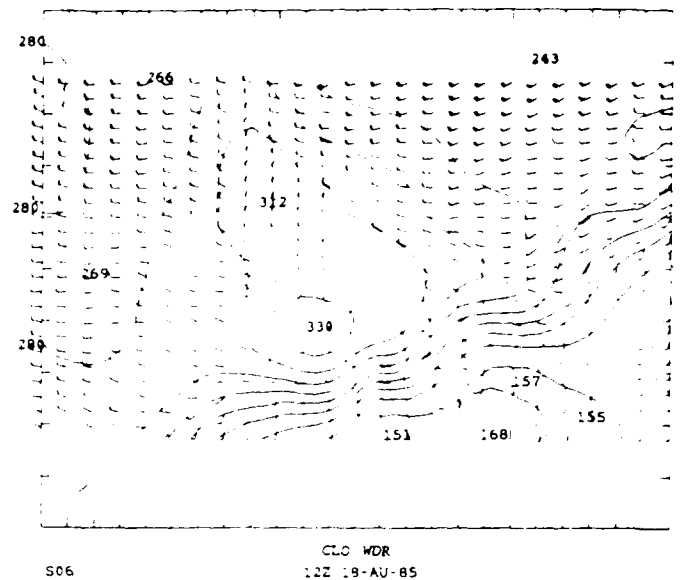

Figure 4. Short-period wind direction variations observed at the frontal interface during the passage of Hurricane Danny over central Pennsylvania in 1985. Winds over a 24-hour period from about 1.6 to 8.5 km are shown.

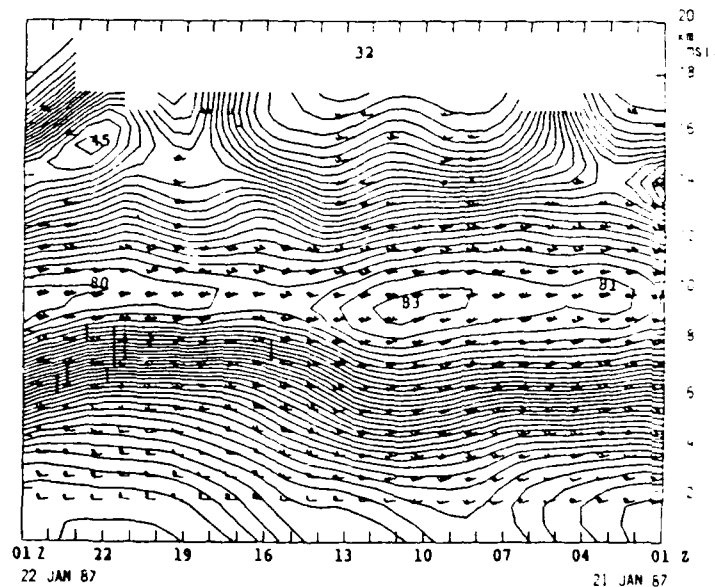

Figure 5. Height and time dependent wind speeds recorded while the jet stream was located above one of the VHF wind profilers for a 24-hour period in January 1987. The highest speeds (> 83 m/s) were occurring between 9 and 10 km altitude. The vertical bars at altitudes ranging from 6 to 9 km denote reports from pilots of clear air turbulence.

nected in series-parallel combinations. The connected transducers are driven by four high fidelity power amplifiers, each with a 1600 Hz signal of different phase.

Antennas for the combined radiometer systems do not have to be pointable, and some operate with only a single overhead pointing angle. However, additional information that can be used in extracting the humidity and temperature profiles may be derived if one measures the brightness temperature as a function of the zenith pointing angle. The Penn State radiometer is a research system and measurements made with it can provide excellent material for many different individual research studies. Thus, to optimize its flexibility, the radiometer is equipped with a computer-controlled tilting and reflecting plate. This not only allows the vertical scanning angle to be changed easily, but also facilitates calibration of the system using external controlled-temperature sources.

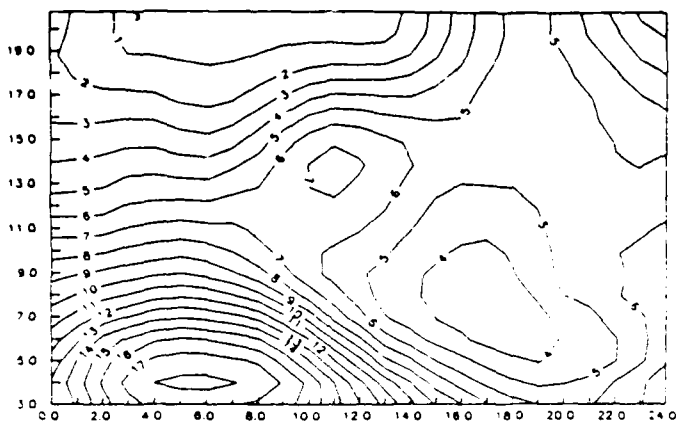

Figure 6. Combined sodar and UHF profiler wind speeds recorded from 300 to 2000 m altitude above San Nicolas Island, Calif., on July 4, 1987. Fine structure in the changing winds is apparently associated with evolution of the offshore Catalina Eddy.

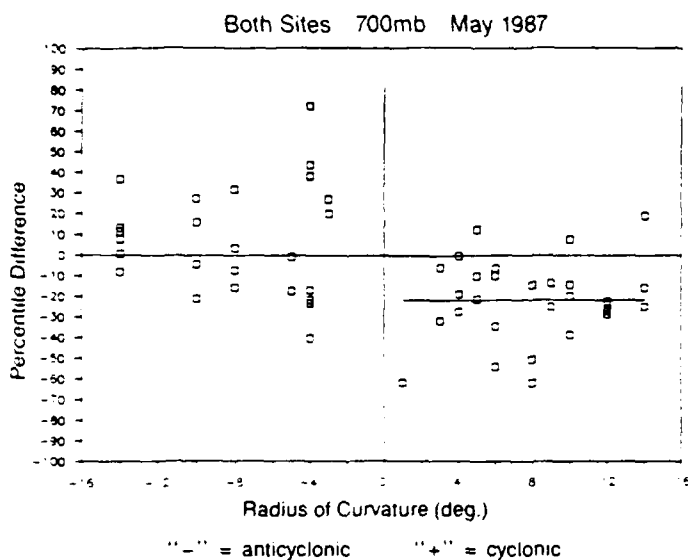

Figure 7. Percentile differences between winds analyzed with a numerical analysis and prediction model and those measured with the McAievey's Fort and Crown VHF profilers. For cyclonic (0 to +16) streamline curvatures, the model underestimates the actual wind speeds by an average of 21%.

Some Fundamentals of Signal Processing

The VHF and UHF profilers transmit as many as 4,200 to 10,000 pulses per second, respectively. The sodar, on the other hand, transmits only one pulse every six to ten seconds. The difference in the frequency of pulse transmission between the EM and AC systems is caused by the roughly million-fold difference in velocity of EM and AC waves in the atmosphere; 3×10^8 m/s and about 340 m/s, respectively. The difference in pulse repetition frequency, or period, also fundamentally alters the way the received signals must be processed.

As each pulse of transmitted energy propagates away from the system, it is continuously scattered and absorbed. The operating frequencies for the active remote sensing systems are carefully selected to minimize absorption. It is one of the most important factors limiting the usable range for a given system.

The operating frequencies for wind profilers are chosen so that $\lambda/2$ falls within the observed spectrum of atmospheric turbulence (typically $10 \text{ cm} < \lambda/2 < 10 \text{ m}$). For radar wavelengths from roughly 50 cm to 10 m, the scattering will be predominately from turbulence generated refractive inhomogeneities. The wavelengths are chosen to be as long as possible in order to minimize the potential for interference from particles such as raindrops. (In the following arti-

cle, G. Forbes discusses a useful application for rain contaminated signals). For scattering by particles, as the wavelength decreases, the efficiency of the scattering increases, approximately as the inverse fourth power of λ .

However, when the system is designed to sense raindrops, the optimum wavelength requires yet another compromise. The scattering efficiency is actually highest when the scatterer size and λ are comparable. But in this case, interpretation of the scattering from the heterogeneous "soup" of particles normally in the atmosphere is difficult. If the wavelength is chosen such that λ is much larger than the size, then the Rayleigh approximation may be applied, and it is far easier to relate the received power to the physical properties of the scattering raindrops. It is for this reason that the cloud drop radar is operated at 94 GHz and that optical frequency laser-based systems are best suited for studies of atmospheric aerosol and dust.

Thus the instantaneous output of the receiver's detector is the power or amplitude of the scattered signal as a function of time (or range) from the volume which is defined by the beamwidth of the antennas and half the pulse length in space. Actually, the detected output from a coherent (Doppler sensing) system consists of two parts; the real (R) and the imaginary (Q) parts of the complex signal.

In the wind profiling radars, digital samples of the R and Q signals are taken as often as every microsecond, in the 94 GHz cloud radar every 20 nanoseconds. At such high sampling frequencies, only one sample per pulse volume in space or range-gate can be digitized for further real-time processing. First, the series of numbers obtained at each range-gate is averaged over the time domain integration period. Then for each range gate, two time series—the R(t) and Q(t)—of 64 time domain integrated values are formed. A Doppler velocity spectrum for each range gate is calculated using a complex Fast Fourier Transform (FFT) routine in one of the system's computers. (Note that examples of averaged velocity spectra are shown in the following article by Forbes.) Depending on the exact operating mode of the radar, between one thousand and a hundred thousand pulses are transmitted, sampled and processed before computing each velocity spectrum.

By comparison, the propagating AC pulses move sufficiently slowly to be sampled with respect to range. Thus, the velocity spectrum (derived from a 256-point FFT) from a sodar is obtained by sampling with respect to time, equivalent to range. Pulse-pulse averaging of the raw signals is not necessary; in fact it turns out that it cannot be done because the pulses are emitted so infrequently that redundant sampling of the atmosphere in the pulse volume, a requisite for time domain integration, is unlikely unless the winds are calm.

Even after all the above averaging, the individual computed velocity spectra from both radars and sodars are still noisy; that is, the peaks which are eventually related to the motions of the scatterers are poorly defined. Hence averaging of the spectral estimates must now be performed. Typically, anywhere from two to fifty spectra are averaged. Finally, the mean and fluctuating velocities in each range gate and for each beam are determined from the frequency offset of the peaks in the averaged spectra and the width of the spectra, respectively. Computing the atmospheric velocity components either in meteorological coordinates (east, north and vertical) or flow coordinates (streamwise, lateral, and flow vertical) is the last straightforward, albeit computationally messy, task.

All of the above must, of course, be carried out continuously and in real time. It is electronically possible only because the computer revolution of the last two decades has produced high performance, relatively low-cost machines capable of carrying out these procedures. Each radar wind profiler has about five computer processors plus a large minicomputer. The actual number of microprocessors is somewhat ambiguous because the computer-like boards that perform the time-domain integration, system control, etc. have about 1000 integrated circuits, many of which are themselves microprocessors. The minicomputer spends about 47 minutes of each hour performing the spectral computations. In the remaining time, such operations as averaging, coordinate transformations, and archiving are carried out. Each Doppler sodar has two computers: a special purpose high-speed processor is incorporated into a standard PC-grade machine. The integrated radiometer system

has nine computers: eight microprocessors and one high performance PC-grade machine.

Examples of Profiler Measurements

During routine operation of the wind profilers, one of the computers in the Department's Weather Observatory automatically telephones each system hourly and requests transmission of the previous hour's wind data. In the Observatory, the measurements are displayed in color using a format similar to that shown in Figure 4. The wind barbs illustrate the hourly directions and speeds as a function of altitude for the current hour as well as the previous 24 hours. Isoleths of speed, direction, or return power (related primarily to the vertical distribution of humidity fluctuations) may also be superimposed.

Figure 4 shows the changing winds as a function of height and time recorded during the latter part of Hurricane Danny's passage over Central Pennsylvania. The "wavy" isopleths of wind direction are representative of mesoscale features of a type we have never before been able to observe. Such patterns are among the many of great interest. For example, these types of wind direction and speed shifts can make the difference between heavy or no precipitation.

The isopleths of windspeed shown in Figure 5 are an example of the display pattern for a situation in which the core of a high speed jet stream was immediately above the radar. The short vertical bars toward the left-hand side at altitudes ranging from 6 to 8 km designate pilot reports of moderate and severe clear air turbulence. One airline report—presumably from a copilot—stated, "Passengers in the aisles; pilot very upset." The measurements we are now obtaining of jet stream structure, dynamics and turbulence are so superior to any previously available that we may, literally, be able to rewrite the textbooks discussing their physical properties and behavior. New questions are constantly being raised regarding such issues as the physical dimensions of the jet stream, the role of topographically induced waves in exciting clear air turbulence, the life cycle of clear air turbulence, and the characteristics and forcing of horizontal meanders of the jet stream's high speed core.

The next example, Figure 6, is another first—in two respects. The isopleths are of wind speed in the marine atmospheric boundary layer above San Nicolas Island (SNI), about 100 miles off the coast of California. July 4, 1987 was only one day in the three-week FIRE Experiment, an international experiment involving nearly 200 scientists. Penn State's sodar and profiler measurements were the most detailed and high quality continuous wind profiles ever compiled for the atmospheric environment in which marine stratus clouds are a persistent feature of great interest. Both locally and globally, these clouds are a phenomenon of great climatic importance.

Figure 6 is also unique in that it is an illustration of the first database of combined sodar and radar wind profiler measurements. The integrated database was compiled by using the Doppler sodar for measurements below about 800 m and the profiler for the higher altitudes. Experiments such as the one at SNI and others now in progress at Penn State are demonstrating, among other things, that the absolute and relative accuracies of the different profiling systems are so good that one of the major uncertainties in calibration is the position of reference balloons with respect to each system. The atmosphere is, of course, spatially inhomogeneous as well as temporally variable. Thus another new area of research is examining the distances over which variables such as wind speed and direction and temperature are correlated as a function of the large-scale weather conditions.

Figure 7 illustrates how measurements from the wind profilers have been used for the first time to examine the performance of a state-of-the-art numerical weather analysis and prediction model. Conventional upper air radiosonde measurements are used in the new Nested Grid Model (NGM) of the National Meteorological Center for operational weather analysis and forecasting purposes. Wind measurements made with the Penn State profilers provide an independent continuous database against which the output of such numerical models can be compared. Figure 7 shows that when the streamlines are cyclonically curved, the winds initially analyzed by the model are on the average 21% too low. We were able to deter-

mine that not only the initially analyzed but also the forecast winds were too low in speed. Students in the Weather Observatory often comment that the NGM tends to underestimate precipitation. Although precipitation forecasting involves consideration of many more factors than just the speed of the wind in cyclones, the question of potential relationships between the clearly established speed errors and the undertorecasting of precipitation is one which will certainly receive further investigation.

Impact on the Research and Instructional Programs

The above examples hint at the magnitude of the impact which some of the individual profiling systems are now having on the Department's ongoing research program. In 1987, the following graduate students completed the first profiler-based M.S. thesis studies:

Catherine Ann Carlson: "Kinematic Quantities Derived from a Triangle of VHF Doppler Wind Profilers"

Larry W. Knowlton: "Kinematic Diagnoses of Frontal Structure and Circulation Derived from Two- and Three-Station VHF Doppler Wind Profiler Networks."

Theodore A. Messier: "Development and Evaluation of an Automated Toxic Corridor Emergency Response System."

Paul J. Neiman: "Wind-Profiler-Derived Temperature Gradients and Advections."

William J. Svrett: "Some Applications of 50-MHz Wind Profiler Data: Detailed Observations of the Jet Stream."

There are currently nine more students with M.S. and Ph.D. theses in progress. At least six other students are working on profiler-related thesis problems such as the analysis of related research aircraft data or on analyses for which profiler data are being used to supplement a conventional database. Nearly half the Department's faculty are serving as research advisors to these students. The profiler data are being used with increasing frequency in the classroom and in the weather observatory. Last, but not least, more and more of the resident undergraduate and graduate students are taking advantage of the systems—even if they are not directly involved in profiler-related research or studies. These students have recognized that at Penn State they have a unique opportunity to learn some 21st century meteorology *now*.

Acknowledgements: Successful completion of the profiler facilities discussed in this and the following article by G. Forbes has been possible only because a very special working environment exists in the Department of Meteorology. For dedicated and outstanding assistance in their respective areas of expertise, I wish to especially acknowledge C. Fairall, G. Forbes, C. Hosler, J. Olivero, R. Peters, A. Person, R. Thompson, and S. Williams. Critical outside contributions of scientific, engineering, and technical assistance were made by C.G. Little, D. Merrit, K. Moran, J. Snider and R. Strauch at NOAA's Wave Propagation Laboratory; J. Brosnahan at Tycho Technology, Inc.; A. Parrish at Millitech, Inc.; K. Underwood at XonTech, Inc.; and J. Reagan at the University of Arizona.

In the following article by Forbes and Carroll, the systems application in the MIST:SPACE experiment was made possible by a National Science Foundation grant—some funds in that grant were provided through NASA via an interagency agreement. Successful field deployment would not have been possible without the outstanding support provided by Scott Williams and Bob Peters.

Most of the hardware funding was provided through DOD UIR (Air Force Office of Scientific Research) and URI (Office of Naval Research) Grant programs. Other contributors included Penn State, the College, and E.I. DuPont Corp.

To the extent that one can dedicate equipment, it is appropriate to dedicate Penn State's profilers to the meteorology students, not just to those who helped to make the facility a reality, but also to those whose past, present and future use of the equipment will further knowledge of the atmospheric environment in which we live.

After completing his formal training in physics and meteorology at the University of Wisconsin and a DAAD Postdoctoral Fellowship at the University of Hamburg, DENNIS THOMSON joined the Penn State faculty in 1970. He has since also been a visiting scientist at the National Center for Atmospheric Research and at Risø National Laboratory in Denmark. In 1986 he served as the G.J. Haltiner Research Chair Professor at the Naval Postgraduate School. Of his diverse interests in atmospheric measurements and remote sensing, he says, "Research in natural science is much like a good marriage; as your experience matures, you increasingly appreciate the beauty within your partner."