

9

DOT/FAA/DO-90/3

**AD-A222 295**

# National Airspace System

## Ground-Ground Communications Operational Concept

NAS-SR-1362



U.S. Department of Transportation  
Federal Aviation Administration

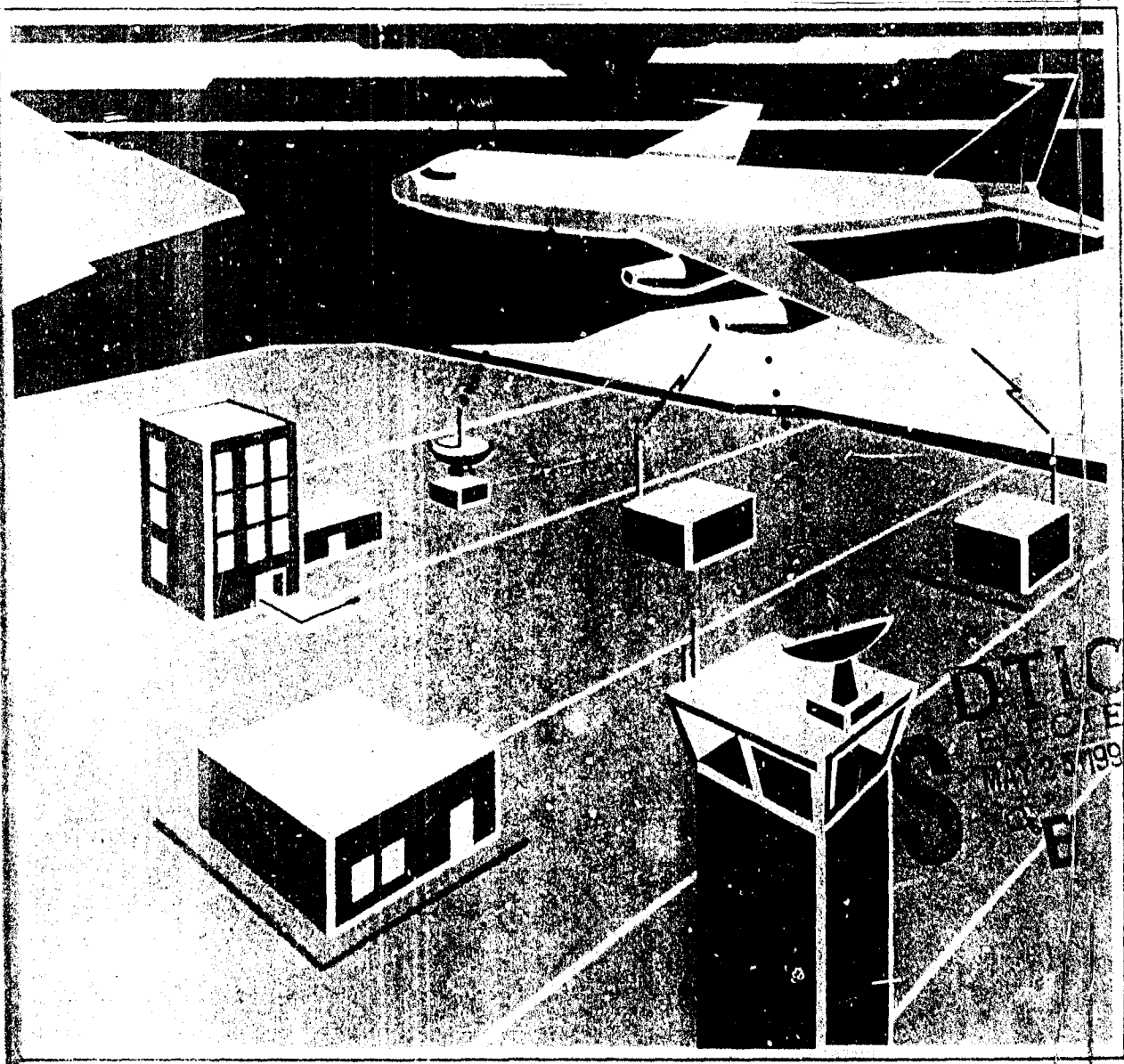

STRICTLY CONFIDENTIAL  
MAY 1990

Document is available to the public through the National Technical Information Service Springfield, VA 22161

**90 05 25 057**

May 1990

This Page  
Reproduced From  
Best Available Copy

1. Report No. NAS-SR-1362		2. Government Accession No.		3. Recipient's Catalog No.	
4. Title and Subtitle Ground-Ground Interfacility Communications Connectivity Concept of Operations				5. Report Date February 1990	
				6. Performing Organization Code	
7. Author(s) William Trent, Rodney Kuhn, Thomas Pickerell				8. Performing Organization Report No.	
9. Performing Organization Name and Address Computer Resource Management, Inc. 2110-C Gallows Road Vienna, Virginia 22182				10. Work Unit No. (TRAIS)	
				11. Contract or Grant No. DTFA01-88-Y-01073	
12. Sponsoring Agency Name and Address U.S. Department of Transportation Federal Aviation Administration 800 Independence Ave., SW Washington, DC 20591				13. Type of Report and Period Covered	
				14. Sponsoring Agency Code ADS-110	
15. Supplementary Notes					
16. Abstract  A requirement for the National Airspace System (NAS) is to provide for ground-ground interfacility communications connectivity, as identified in the NAS System Requirement Specification, NAS-SR-1000. This document presents a concept of operations for ground-ground interfacility communications connectivity. It describes ground-ground interfacility communications connectivity capabilities and shows the relationships between subsystems, facilities, information, and operators/users. It is intended to provide a common perspective for personnel involved in ground-ground interfacility communication connectivity activities, assist in determining whether ground-ground interfacility communications connectivity meet formal requirements, and support coordination among the organizations involved.					
17. Key Words Ground-Ground Interfacility Communications Connectivity National Airspace System Air Traffic Control			18. Distribution Statement Document is available to the public through the National Technical Information Service Springfield, VA 22161		
19. Security Classif. (of this report) UNCLASSIFIED		20. Security Classif. (of this page) UNCLASSIFIED		21. No. of Pages 50	22. Price

21-91

DTIC  
ELECTE  
MAY 25 1990  
S E D

TABLE OF CONTENTS

	Accession For	Page
LIST OF FIGURES	NTIS GRA&I <input checked="" type="checkbox"/>	iii
LIST OF TABLES	DTIC TAB <input type="checkbox"/>	iii
	Unannounced <input type="checkbox"/>	
	Justification	
1.0 INTRODUCTION	By _____	1-1
1.1 Background	Distribution/	1-1
1.2 Objective	Availability Codes	1-1
1.3 Scope	Avail and/or Dist Special	1-1
1.4 Methodology	<b>A-1</b>	1-1
1.5 Document Organization		1-3
2.0 GROUND-GROUND INTERFACILITY COMMUNICATIONS CONNECTIVITY OPERATIONS		2-1
2.1 Support		2-1
2.2 Information		2-6
2.2.1 Communications Between NAS Facilities		2-7
2.2.2 Communications Between FAA and Non-NAS Facilities		2-8
2.2.3 Secure Communications Between NAS and DoD Facilities		2-8
2.3 Functions		2-9
2.3.1 Automated Flight Service Station (AFSS) Specialists		2-9
2.3.2 Area Control Facility (ACF) Specialists		2-11
2.3.3 Airport Traffic Control Tower (ATCT) Specialists		2-13
2.3.4 FAA HQ Operations Center Specialists		2-14
2.3.5 Air Traffic Control Command Center (ATCCC) Specialists		2-17
2.4 Correlation with Operational Requirements		2-18
2.5 Operational Sequences		2-21
2.5.1 Communications Between NAS and Non-NAS (Data) Sequence		2-21
2.5.2 Communications Between NAS Facilities (Data) Sequence		2-21
2.5.3 Communications Between NAS Facilities (Voice) Sequence		2-24
2.5.4 Secure Communications Between DoD and NAS Facilities Sequence		2-24
2.5.5 Communications Between NAS and Non-NAS (Voice)/FAA HQ Ops Sequence		2-24



TABLE OF CONTENTS (Con't)

	<u>Page</u>
2.6 Operational Scenario	2-28
2.6.1 Communications Between NAS and Non-NAS (Data) Scenario	2-28
2.6.2 Communications Between NAS Facilities (Data) Scenario	2-28
2.6.3 Communications Between NAS Facilities (Voice) Scenario	2-28
2.6.4 Secure Communications Between DoD and NAS Facilities Scenario	2-32
2.6.5 Communications Between NAS and Non-NAS (Voice)/FAA HQ Ops Scenario	2-32
REFERENCES	RE-1
GLOSSARY	GL-1
ACRONYMS/ABBREVIATIONS	AA-1

## LIST OF FIGURES AND TABLES

<u>Figure Number</u>		<u>Page</u>
2-1	Overview of NAS/User Interfaces for Ground-Ground Interfacility Communications Connectivity	2-2
2-2	Communications Connectivity Block Diagram	2-3
2-3	AFSS Operational Flow Diagram	2-10
2-4	ACF Operational Flow Diagram	2-12
2-5	ATCT Operational Flow Diagram	2-15
2-6	FAA HQ Ops Center Operational Flow Diagram	2-16
2-7	ATCCC Operational Flow Diagram	2-19
2-8	Communications Between NAS and Non-NAS (Data) Sequence Diagram	2-22
2-9	Communications Between NAS Facilities (Data) Sequence Diagram	2-23
2-10	Communications Between NAS Facilities (Voice) Sequence Diagram	2-25
2-11	Secure Communications Between DoD and NAS Facilities Sequence Diagram	2-26
2-12	Communications Between NAS and Non-NAS (Voice)/FAA HQ Ops Sequence Diagram	2-27
2-13	Communications Between NAS and Non-NAS (Data) Scenario	2-29
2-14	Communications Between NAS Facilities (Data) Scenario	2-30
2-15	Communications Between NAS Facilities (Voice) Scenario	2-31
2-16	Secure Communications Between DoD and NAS Facilities Scenario	2-33
2-17	Communications Between NAS and Non-NAS (Voice)/FAA HQ Ops Scenario	2-34
<u>Table Number</u>		
2-1	Ground-Ground Interfacility Communications Connectivity Operational Requirements Correlation	2-20

## 1.0 INTRODUCTION

### 1.1 Background

The transfer of information between ground based facilities (ground-ground) such as flight plans, flight movement, weather, surveillance, monitoring and control information is essential for safe and efficient operation of the National Airspace System (NAS). This information is passed using both voice and data communications. Additionally, the communication system utilized must be reliable and provide voice privacy when required.

### 1.2 Objective

The objective of this Operational Concept, which is based upon the National Airspace System System Requirements Specification (NASSRS), is to describe how ground-ground interfacility communications connectivity will be utilized in the NAS "end state" system. This document is intended as a descriptive document to provide management and technical personnel of the FAA, as well as outside organizations, with a clear understanding of how ground-ground interfacility communications connectivity will be provided. More specifically, the purpose of this document is to:

1. Provide a common operational perspective across subsystems, operators, and users.
2. Show the interrelationship between subsystems, facilities, information, and operators/users.

### 1.3 Scope

This operational concept describes the ground-ground communications connectivity provided as outlined in Section 3.6.2 of the NASSRS. The operations described are limited to those associated solely with ground-ground communications connectivity.

The specific paragraphs in the NASSRS Section 3.6.2 are as follows:

#### 3.6.2 GROUND-GROUND INTERFACILITY COMMUNICATIONS CONNECTIVITY

- 3.6.2.A Communications between NAS Facilities
- 3.6.2.B Communications between FAA and Non-NAS Facilities
- 3.6.2.C Secure Data Communications between NAS and DoD Facilities

### 1.4 Methodology

The methodology employed to develop this operational concept is similar to the methods and tools used for system development in that successive levels of decomposition of the communications functions are

represented. This document starts with the overall concept and proceeds to its most elemental levels of support, diagrammatic tools, and techniques that constitute ground-ground interfacility communications connectivity support. These analytical tools are:

1. Operational Block Diagram/Description. The operational block diagram illustrates the connectivity between major elements of the NAS, i.e., processors, specialists/controllers, and the user for those elements that support the service. The operational block diagram in this operational concept is extracted from the overall NAS operational block diagram. Principal features of the operational block diagram/description include the following:
  - a. Each specialist/controller is indicated by a number. This number remains the same in every NASSRS operational concept.
  - b. Dotted lines segregate facilities.
  - c. Solid lines show digital data flow, and voice data flow is also shown. Each type of data flow is appropriately labeled.
  - d. The blocks within each facility are the major processors.
2. Operational Flow Diagrams/Descriptions. An operational flow diagram and associated description for each specialist provides detail about the inputs, processes, outputs, and interfaces for each operator; thus, the operational flow diagram provides an expansion of each element of the NAS shown in the ground-ground interfacility communications connectivity master block diagram. Operational flow diagrams are used to functionally describe the products and services of individual specialists.
3. Operational Sequence Diagrams/Descriptions. The operational sequence diagram and associated description show a typical sequence of steps taken by operators/users in supporting ground-ground interfacility communication connectivity operations. Principal features of an operation sequence diagram include the following:
  - a. Users, specialists, and computer systems involved with providing ground-ground interfacility communication connectivity functions are listed along the vertical axis. When required for clarity, other FAA facilities may also be listed on the vertical axis.

- b. The horizontal axis represents time. Sequential events or functions performed are indicated within separate boxes. Events which may occur simultaneously or near-simultaneously are shown vertically.
- c. Decision points or points where alternate paths may be followed are indicated by a diamond shape.
- d. Circles are connectors and indicate exit to, or entry from, another diagram. Circles with a lower case alphabetic character reference an operator function described in the figure listed below the circle. Circles connect either to another sheet of the same diagram or to another diagram; the relevant figure number is listed underneath if connection is to a different diagram. Thus, the relationship between operator/user interactions and relevant NAS subsystems can be depicted.

### 1.5 Document Organization

The remainder of this document is organized in the following manner. Section 2 is the main body of the document and is divided into six subsections. Section 2.1 provides an overview description of the ground-ground communications connectivity functions and introduces (identifies) the personnel compliment and physical entities (facilities and computer systems), which provide the required support. Section 2.2 describes the information used to provide ground-ground communications connectivity support. Section 2.3 provides descriptions of the functional decomposition of ground-ground communications connectivity services. (Sections 2.1, 2.2, and 2.3 reference related NASSRS 3.6.2 subsystems.) Section 2.4 presents correlation requirements. Section 2.5 provides a sequence of interactions between system and personnel entities during the planning and the implementational phases of ground-ground communications connectivity services. Section 2.6 describes ground-ground communications interfacility operational connectivity scenarios.

## 2.0 GROUND-GROUND INTERFACILITY COMMUNICATIONS CONNECTIVITY OPERATIONS

### 2.1 Support

In order to provide essential services to its users the NAS must ensure it has ground-ground interfacility communications connectivity. Ground-ground interfacility communications are utilized by specialists in Automated Flight Service Stations (AFSS), Area Control Facilities (ACF), and Airport Traffic Control Towers (ATCT) to pass information between facilities. Additionally, flight information must be passed between these ATC facilities, the FAA Headquarters Operation Center and the Air Traffic Control Command Center (ATCCC) in Washington, D.C.

The NAS provides an interfacility communications connectivity, for the transfer of information among all other elements and between these elements and the specialists, external users, military ATC facilities and government agencies by utilizing, as a minimum, the following:

- Voice Networks
- Data Networks
- Independent Emergency Communications

The NAS transfers information between NAS facilities and non-NAS ground facilities via ground-ground voice and data communications connectivity within the en route and terminal airspace of the conterminous United States, Alaska, Hawaii, and Puerto Rico. Ground-ground communications within the NAS consists of equipment that enables NAS specialists to communicate with specialists in adjacent NAS facilities and non-NAS facilities.

In addition to voice connectivity, data communications is passed between all NAS facilities, selected DoD facilities, and non-NAS facilities. This data communication interface capability includes the transmission of surveillance data, weather products, air traffic control, flight planning and maintenance, and operations information. The exchange of surveillance information with properly equipped sources external to the NAS compliments the NAS surveillance coverage. These sources include: joint use surveillance facilities, military radars and surveillance processing facilities, and airline tracking networks. Airline dispatch offices are connected to provided automatic flight plan filing and cancellation capabilities.

Figure 2-1 is an overview of NAS/user interfaces for ground-ground communications connectivity and illustrates the NAS facilities and systems involved.

Figure 2-2 is an operational block diagram showing the interrelationships between equipment, facilities, operators/users and the information necessary to support ground-ground communications.

The following paragraphs summarize operations at each type of facility shown in Figure 2-2.

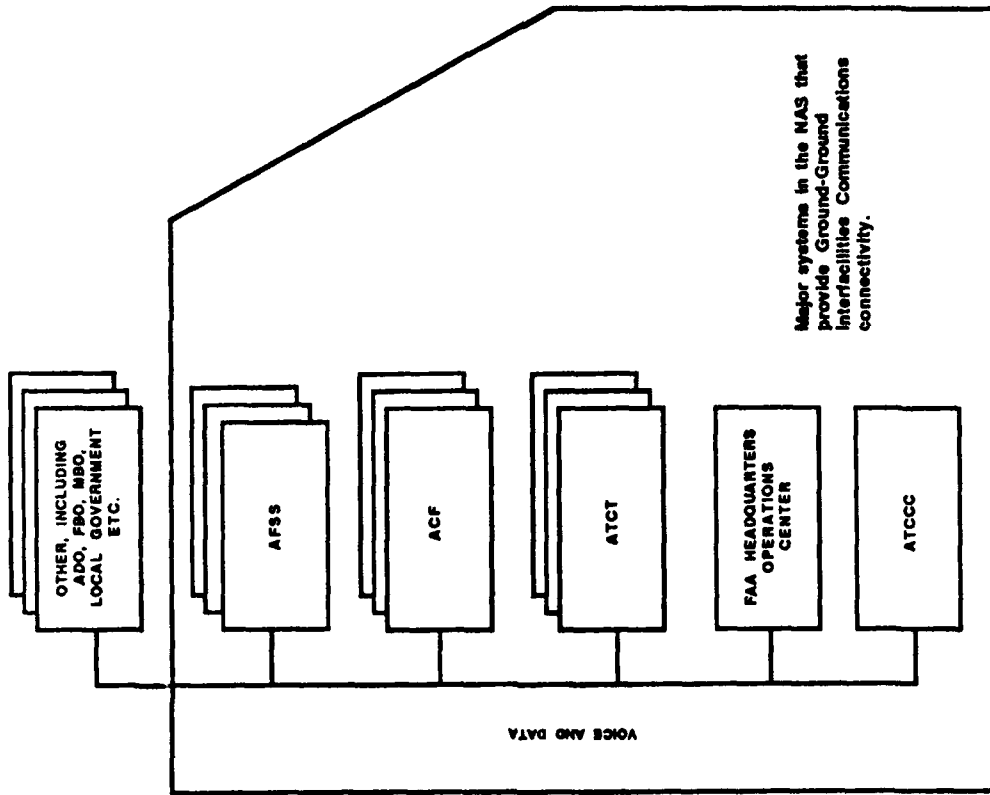

FIGURE 2-1  
OVERVIEW OF NAS/USER INTERFACES FOR  
GROUND-GROUND INTERFACILITY COMMUNICATIONS CONNECTIVITY



Position(s) 2 through 4, 20, 21: AFSS Specialists

Functions: Preflight Briefings, Inflight Briefings, En Route Flight Advisor, Service (EFAS), Weather Broadcasts and NOTAM Advisories.

Description: Air traffic personnel that provide pilot briefings; en route communications; and VFR search and rescue services; relay ATC clearances; originate Notice to Airmen; broadcast aviation weather; receive and process VFR and IFR flight plans; and monitor NAVAIDS.

**Procedures:** FAA, Flight Service Station Procedures (7110.10I), Chapter 4, Section 3; Chapter 6, Sections 2-5

**Projects:** NAS Plan, Chapter III, Flight Service and Weather Systems - Automation: Project 1, Flight Service Automation System (FSAS); - Communications: Project 13, Integrated Communications Switching System; Chapter V, Interfacility Communications Systems; Project 2, Data Multiplexing Project 3, RML Replacement and Expansion; Project 7, National Airspace Data Interchange Network (NADIN) II; Project 8, Radio Control Equipment (RCE).

Position(s) 6 through 8, 12, 22 and 23: ACF Specialists

Function: Approach/Departure and En Route Control, Area Management, and Traffic Management.

Description: These controllers expedite the safe movement of air traffic through the Area Control Facility airspace in both the terminal and en route environments. Traffic Management coordinators provide support to the air traffic specialists by providing traffic flow information for the controllers use. Area/supervisory personnel provide air traffic control management.

**Procedures:** FAA, Air Traffic Control (7110.65I); Chapter 2, Section 1; Chapter 3, Section 10; Chapter 4, Section 3 and 7; Chapter 9, Section 1 through 3

**Projects:** NAS Plan, Chapter III, En Route Systems: Project 11, Voice Switching and Control System (VSCS); Project 15, Area Control Facilities (ACF); Chapter V, Interfacility Communications Systems Terminal Systems: Project 2, Data Multiplexing; Project 3, RML Replacement and Expansion; Chapter 7, National Airspace Data Interchange Network (NADIN) II; Chapter 8, Radio Control Equipment (RCE).

Position(s) 9 through 11: ATCT Controllers

Function: Local Control, Ground Control, and Clearance Delivery Control.

Description: Specialists that control aircraft arriving or departing an airport with an ATCT, and operating within the airport traffic control area or taxiing on the airport.

Procedures: Air Traffic Control (7110.65F); Chapter 2, Section 1; Chapter 3, Section 10; Chapter 4, Section 3 and 7; Chapter 9, Section 1 through 3

Projects: NAS Plan, Chapter 3, Terminal Systems: Communications; Project 12 Tower Communications System; Chapter V, Interfacility Communications Systems: Project 2, Data Multiplexing; Project 3, RML Replacement and Expansion; Chapter 7, National Airspace Data Interchange Network (NADIN) II; Chapter 8, Radio Control Equipment (RCE).

Position 1: FAA Headquarters Operations Center Specialists

Function: Operations Center, Aviation Command Center, Management Operations Center, and Intelligence Support.

Description: The primary mission of the operations center specialists is to provide round-the-clock support to FAA's key management officials including the Secretary of Transportation, FAA Administrator, Deputy Administrator, Executive Directors, and Associate Administrators during both day-to-day operations and crises. These specialists collect information, coordinate and direct FAA resources and operations during times of crisis. Numerous internal and external communications systems (secure and non-secure), and other information gathering systems, are available to these specialists to notify personnel, activate resources, and support the agency head and other key decision makers. Additionally, a telecommunication center, which is remotely located, provides support to the operation center specialists. The telecommunication center is equipped with secure, FAA proprietary, major air carrier subscriber system, commercial public and teletype systems. The telecommunication center also has both secure and non-secure facsimile capabilities. Secure telephone service is also available to the specialists.

Procedures: FAA Order 1770.6A, Operations Center

Projects: NAS Plan, Chapter 5 Interfacility Communications Systems: Switching; Project 7, National Airspace Data Interchange Network (NADIN) II; Chapter 6: System Improvement, Project 14, National Radio Communications Systems (NARACS).

Position(s) 13 through 15: Air Traffic Control Command Center (ATCCC) Specialists

Function: Central Flow Control (CFCF), Central Altitude Reservation (CARF), Airport Reservation (ARO), ATC Contingency Command Post.

Description: The ATCCC specialists provide national level management and monitoring of current air traffic flow, aircraft operations, en route sector and airport utilization, and future system utilization.

Procedures: FAA Order 7210.47A Traffic Management System

Projects: NAS Plan, Chapter III, Flight Service and Weather Systems: Project 2, Central Weather Processor (CWP); Project 4, Weather Message Switching Center (WMSC) Replacement. En Route Systems: Project 6, Traffic Management System (TMS); Chapter 5, Interfacility Communications Systems: Project 2, Data Multiplexing; Chapter 6, Maintenance and Operations Support Systems, Project 14: National Radio Communications System (NARACS).

## 2.2 Information

Ground-ground interfacility communications connectivity enable facility managers, supervisors, and/or authorized specialists, and personnel at other FAA-manned facilities to establish communications with personnel in any other FAA-manned facility through the use of commercial communication networks. Ground-ground interfacility communications consists of both voice and data transmissions.

Voice communications consist of both Intercom (IC) and Interphone (IP). Both IC and IP communications have direct and indirect access capabilities.

The ACFs, AFSSs, ATCTs, the FAA Headquarters Operations Center and the ATCCC has interfacility direct-access voice connectivity to coordinate flight data, weather information, and traffic coordination information between them. Each ACF, AFSS, and ATCT is connected to its adjacent ACF, AFSS, and ATCT respectively, as well as associated ATC facilities for the purpose of passing information.

In the event of a ACF failure, adjacent ACFs will no longer have direct-access voice connectivity to the failed ACF. ACF interfacility direct-access back up voice connectivity will be provided by both the adjacent ACFs and designated non-adjacent ACFs. Also in this type of event, ATCTs and AFSSs associated with the failed ACF will be provided interfacility direct-access back up voice connectivity by these same adjacent and designated non-adjacent ACFs. AFSSs also have interfacility direct-access backup voice connectivity with designated ACFs adjacent to the primary ACFs. ATCTs have interfacility direct-access backup voice connectivity with designated ACFs adjacent to the primary ACF.

Indirect-access voice connectivity exist between facilities to pass weather, traffic, and flight plan information. Each ACF is connected to its adjacent ACF, associated ATCTs and AFSSs, the FAA Headquarters Operation Center, ATCCC, airline dispatch offices, designated DoD facilities, and other NAS facilities. ATCTs are connected for indirect-access voice to associated ACFs and AFSSs, other ATCTs associated with the same ACF, the ATCCC and FAA Headquarters Operations Center, airline dispatch offices, designated DoD facilities and other NAS facilities. AFSSs are provided indirect-access voice to associated ACFs and ATCTs, other AFSSs associated with the same ACF, the ATCCC and FAA Headquarters Operations Center, airline dispatch offices, designated DoD facilities, and other NAS facilities. The ATCCC and FAA Headquarters Operations Center are provided interfacility indirect-access voice connectivity with each other, all ACFs, ATCTs, AFSSs, airline dispatch offices, designated DoD facilities and certain other NAS facilities. Additionally, these two facilities are also connected to selected federal and state law enforcement agencies.

Data communication between DoD and NAS facilities is accomplished through several types of switching systems. In particular, DoD facilities data communication is passed to the NAS Interfacility Communications System (NICS) through the DoD Automatic Digital Network (AUTODIN). The AUTODIN passes data communication to two types of switching systems within the NICS. The first, NADIN IA, is a message switched network which provides the connectivity necessary to interface with the NADIN II packet switched network. The NADIN II is the switching system that serves the NAS facilities. It routes data traffic to data users and facilities through the utilizations of the long haul trunks of the Backbone Interconnection Network. This network provides the point-to-point connectivity between the voice and data users of the NICS. The Backbone Interconnection Network connect the NAS facilities (ATCTs, AFSSs, and ACFs) to each other.

Data communication interface is also provided for NAS weather facilities, navigational aids, and NAS maintenance facilities. For example, this type of interface would enable NAS maintenance personnel to use a portable maintenance terminal to communicate with an unmanned facility to check the status of NAS equipment.

The following paragraphs describe the requirements for ground-ground interfacility communications connectivity.

#### 2.2.1 Communications Between NAS Facilities

The communication systems within the NAS provide the capability for connectivity between selected operating, supervisory, maintenance, and administrative positions at separate NAS facilities. The facilities include Automated Flight Service Stations (AFSS), Area Control Facilities (ACF), Air Traffic Control Towers (ATCT), FAA Headquarters Operations Center, and the Air Traffic Control Command Center (ATCCC).

In addition to direct-access connectivity the NAS maintains inter-facility direct-access backup voice connectivity in the event of an unplanned facility outage.

The NAS provides the capability to interface with public, private, and other government-owned data communications networks, such as the Automatic Digital Network (AUTODIN), to pass data between NAS facilities, DoD, and other non-NAS facilities.

The NAS Interfacility Communication System (NICS) architecture combines and integrates communication functions into one network. The NICS includes the equipment which provides voice and data communication interconnectivity between facilities and sites within the NAS. The NICS will also provide voice and data communication access to other systems external to NAS (e.g., AUTOVON). The transmission function of the NICS provides the connectivity to the distributed facilities and equipments of the NAS. The switching functions of the NICS adds operational flexibility needed to reconfigure resources (combine and decombine sectors) or reroute service in the event of equipment failure.

#### 2.2.2 Communications Between FAA and Non-NAS Facilities

The NAS is interfaced with non-NAS facilities, including airline dispatch offices, federal and local law enforcement agencies, U.S. and foreign military and ATC facilities. The DoD facilities include air defense, ATC facilities, base operations centers, and Strategic Air Command (SAC) centralized scheduling units.

Communications between FAA and non-NAS facilities except DoD is accomplished by use of the Private Automatic Branch Exchange (PABX). The PABX is also used to provide telephone call switching capabilities between offices and work areas located within the ACF building and for access to the public switched network and the Federal Telecommunications System (FTS). Communications interface between FAA and DoD facilities, excluding ATC, is provided by Automatic Voice Switching Network (AUTOVON). AUTOVON is a worldwide switched voice telephone system providing dedicated service to the DoD and certain other government departments and agencies. Because of the required interface between military aviation and the FAA for coordination of aviation activities, the FAA has access to the AUTOVON network at the Headquarters level, both Washington and Regional, and at certain facilities such as ACFs and AFSSs. AUTOVON access provides the FAA with direct dialing capabilities to DoD Headquarters (Pentagon), most U.S. military bases in the U.S. and overseas, and the FAA's offices in foreign countries.

#### 2.2.3 Secure Communications Between NAS and DoD Facilities

The NAS provides the capability for secure voice and data communications between selected NAS facilities and between selected NAS facilities and DoD facilities. This capability enables both classified and unclassified information to be passed between facilities.

The Automatic Digital Network (AUTODIN) is a high-speed, computer-controlled communications system that is used by both civil and military agencies for classified communications. FAA Headquarters, regional headquarters, and ACFs have AUTODIN capability.

All classified message traffic is encrypted entering the AUTODIN system, transmitted over each link of the network, and restored to the original state by decryption equipment at ACFs.

FAA facilities having access to AUTODIN use it for management communications with all other government agencies served by connected elements of the National Communication System (NCS). Unclassified messages addressed to FAA activities served by AUTODIN and also addressed to activities served only by FAA systems are forwarded to all addresses via the agency system.

### 2.3 Functions

The following paragraphs describe in more detail the functions provided by the specialist positions introduced in Section 2.1. The operational flow diagrams associated with each paragraph illustrate the information flow between the specialist within their respective facility and the user, and between the specialist and data processing equipment. The functions performed by the NAS are explicitly covered by requirements specified in the NASSRS. The pertinent NASSRS paragraphs that specify the function being performed by the NAS are referenced in each of the paragraphs that follow.

#### 2.3.1 AFSS Specialists (Positions 2 through 4, 20, 21)

The AFSS Specialists coordinate flight service functions with other specialists through the Flight Service Data Processing System (FSDPS) for data and the Integrated Communications Switching System (ICSS) for voice communication. This communication capability is available continuously to specialists and can be reconfigured to the operational needs of the specialist.

Figure 2-3 is an operational flow diagram describing the ground-ground communication connectivity interfaces provided to the specialists at the AFSS. Functions performed by the equipment and these specialists are lettered within each block and are described in the corresponding paragraphs below.

- a. FSDPS Processing. Data communication between NAS facilities is provided by the FSDPS. The FSDPS is part of the ACF that provides weather and flight data to specialists in AFSSs. The FSDPS provides the processing required to support the operation of the AFSS workstations, interfaces for pilots over

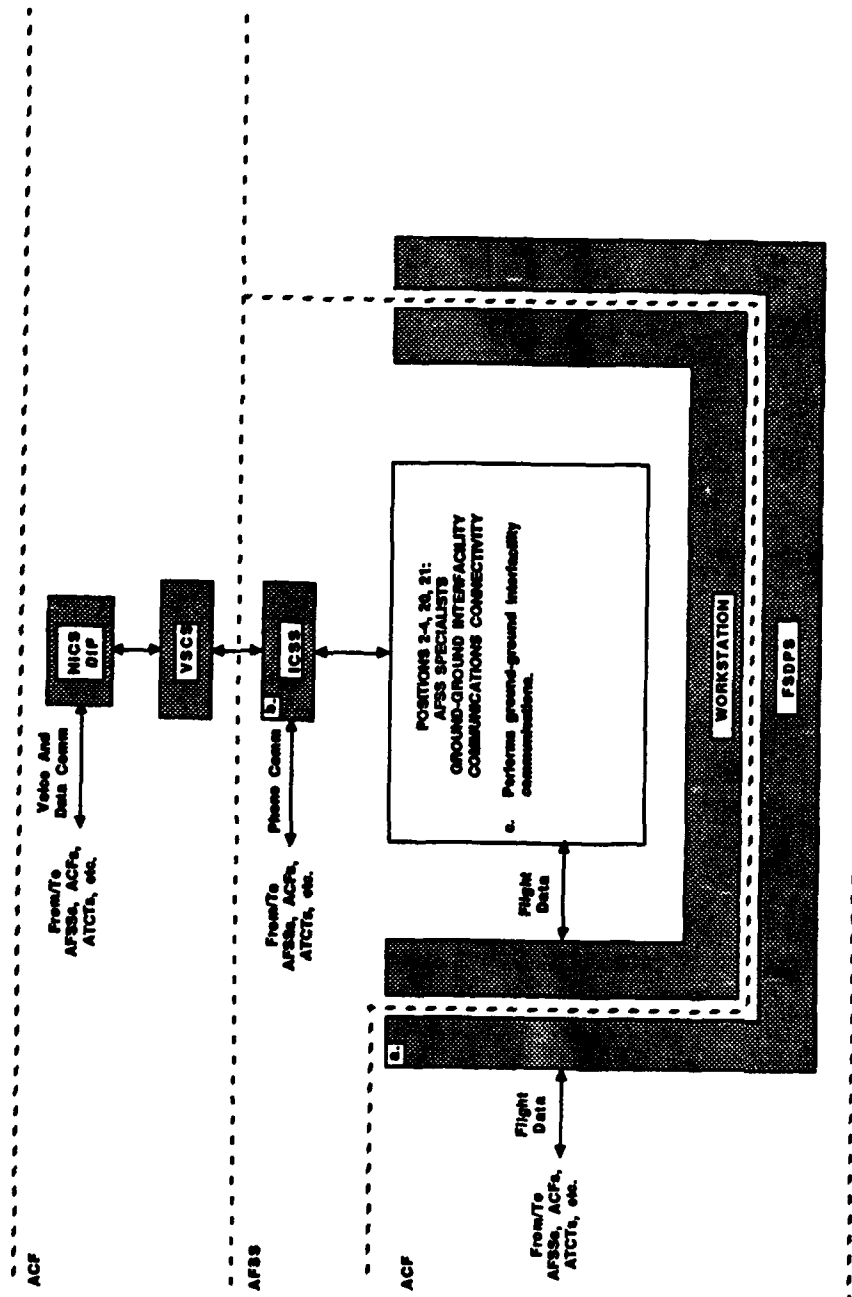

FIGURE 2-3  
 POSITIONS 2-4, 20, 21: AFSS SPECIALISTS  
 OPERATIONAL FLOW DIAGRAM FOR  
 GROUND-GROUND INTERFACILITY COMMUNICATIONS CONNECTIVITY

commercial telephone, and enables the specialist to perform preflight and inflight weather briefings and file/amend flight plans.

**NASSRS Requirement 3.6.2.A**

- b. Integrated Communications Switching System (ICSS). The ICSS provides ground-ground interfacility communications connectivity between the AFSS and NAS facilities and between AFSS and non-NAS facilities. The ICSS at the AFSS enables specialists to communicate with personnel in the ACF through their VSCS, and ATCTs using their TCS; the ATCCC through the TMVS, and other AFSSs and their ICSSs. The ICSS interfaces with AUTOVON to allow AFSS specialists to contact Military Base Operations (MBOs). The ICSS enables voice communications interface with PABXs for commercial network access, local law enforcement officials, airline dispatch offices, and fixed based operators, foreign ATC facilities, and military users via AUTOVON.

**NASSRS Requirement 3.6.2.B**

- c. Perform Ground-Ground Interfacility Communications. AFSS specialists utilize the FSDPS and ICSS to perform ground-ground communications between NAS and non-NAS facilities.

**NASSRS Requirement 3.6.2.A, B**

**2.3.2 ACF Specialists (Positions 6 through 8, 22 and 23)**

The ACF specialists coordinate flight information with other specialists through the Voice Switching and Control System (VSCS) for voice communication and the Area Control Computer Complex (ACCC) for data communication. This communication capability is available continuously to specialists and can be reconfigured to the operational needs of the specialist.

Figure 2-4 is an operational flow diagram describing the ground-ground communication connectivity interfaces provided to specialists at the ACF. Functions performed by the equipment and these specialists are lettered within each block and are described in the corresponding paragraphs below.

- a. ACCC Processing. The ACCC provides the data processing and data communication between the ACF and other non-NAS facilities such as: airline dispatch office for changing or cancelling prefiled flight plans; foreign ATC facilities to exchange flight plans; and the NORAD to coordinate flight plans. Data communications between NAS facilities is accomplished through the interface of the ACCC and through the

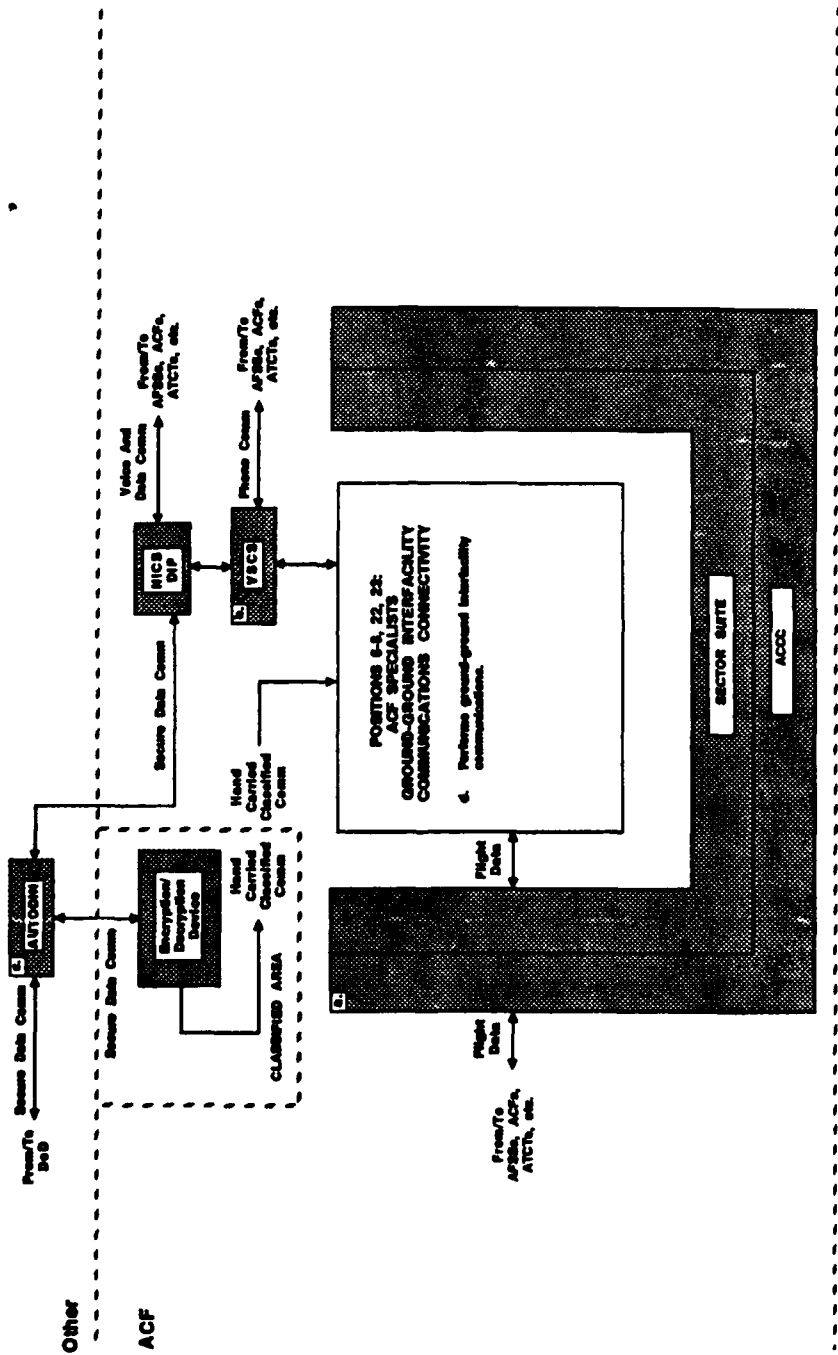

**FIGURE 2-4**  
**POSITIONS 6-8, 22, 23: ACF SPECIALISTS**  
**OPERATIONAL FLOW DIAGRAM FOR**  
**GROUND-GROUND INTERFACILITY COMMUNICATIONS CONNECTIVITY**

NICS to the: air dispatch office, other ACCCs, foreign ATC, FSDPSs, TCCCs, military users, military ATC, DUAT service and Aeronautical Radio (ARINC).

**NASSRS Requirement 3.6.2.A**

- b. Voice Switching and Control System (VSCS). The primary ground-ground interphone function that the VSCS performs as a voice switch is to provide voice connectivity between air traffic operational positions in different locations within the NAS. The VSCS provides standard trunk interfaces to external facilities and systems. The VSCS interfaces with the TCS at the ATCT, ICSS at AFSSs, TMVS for the ATCCC, other VSCSs, military ATC, and military base operations. The VSCS also provides ground-ground voice connectivity with non-NAS facilities such as PABXs for exchange of administrative information and to allow accessing the FTS system and the DoD network, foreign ATC facilities for international operations, airline dispatch offices and North American Air Defense Command (NORAD) for the coordination of flight plan information.

**NASSRS Requirement 3.6.2.B**

- c. AUTODIN for Secure Data Communications. Classified messages (Secret and below) and flight plans are forwarded from DoD facilities to ACFs via the AUTODIN. The AUTODIN is a high-speed, secure, computer-controlled communications system used to transmit both classified and unclassified messages to NAS facilities. Classified messages and flight plans are encrypted before entering the AUTODIN system and are transmitted over each link of the network, and restored to their original state at the receiving ACF. The cryptographic equipment located in ACFs is located separate from and is not interfaced to the computer equipment performing NAS functions.

**NASSRS Requirement 3.6.2.C**

- d. Perform Ground-Ground Interfacility Communications. ACF specialists utilize the ACCC and VSCS to perform ground-ground voice and data communications between NAS facilities and between NAS and non-NAS facilities. ACF specialists utilize the AUTODIN for secure communications with DoD facilities.

**NASSRS Requirement 3.6.2.A, B, C**

**2.3.3 ATCT Specialists (Positions 9 through 11)**

ATCT controllers coordinate flight information with other NAS specialists through the Tower Communications System (TCS) for voice communications and the Tower Control Computer Complex (TCCC) for data communications. This communication capability is available continuously

to specialists and can be reconfigured to the operational needs of the specialist.

Figure 2-5 is an operational flow diagram describing the ground-ground communication connectivity interfaces provided to specialists in the ATCT. Functions performed by the equipment and these specialists are lettered within each block and are described in the corresponding paragraphs below.

- a. TCCC Processing. The TCCC provides the interface with the ACCC at the designated ACF to pass data between facilities.

NASSRS Requirement 3.6.2.A

- b. Communications Between NAS and Non-NAS Facilities. The TCS provides ATCT personnel with operational ground-ground voice communications interconnectivity with other NAS facilities. The TCS interfaces with VSCS for ACFs, ICSS for relay of information to AFSSs, the TMVS to provide voice communication connectivity with the ATCCC, and other ATCT TCSs. The TCS provides tower connectivity for exchange of administrative voice communication via the PABX with other networks such as FTS, and public networks.

NASSRS Requirement 3.6.2.B

- c. Perform Ground-Ground Interfacility Communications. ATCT controllers utilize the TCCC and TCS to perform ground-ground communications with NAS facilities and non-NAS facilities.

NASSRS Requirement 3.6.2.A, B

#### 2.3.4 FAA HQ Ops Center Specialist (Position 1)

FAA HQ Ops Center specialists coordinate information throughout NAS facilities through the Emergency Voice Communications System (EVCS). FAA HQ Ops Center specialists are primarily responsible for aviation incidents and accidents requiring either executive level action or decisions, interagency coordination, or activation of a headquarters crisis response team (e.g., major aircraft crash, air piracy).

Figure 2-6 is an operational flow diagram describing the ground-ground communication connectivity interfaces provided to specialists in the FAA HQ Ops Center. Functions performed by the equipment and these specialists are lettered within each block and are described in the corresponding paragraphs below.

- a. Workstation. The workstation provides the specialist a means of accessing data and communication information to facilitate the ground-ground interfacility communications process. It

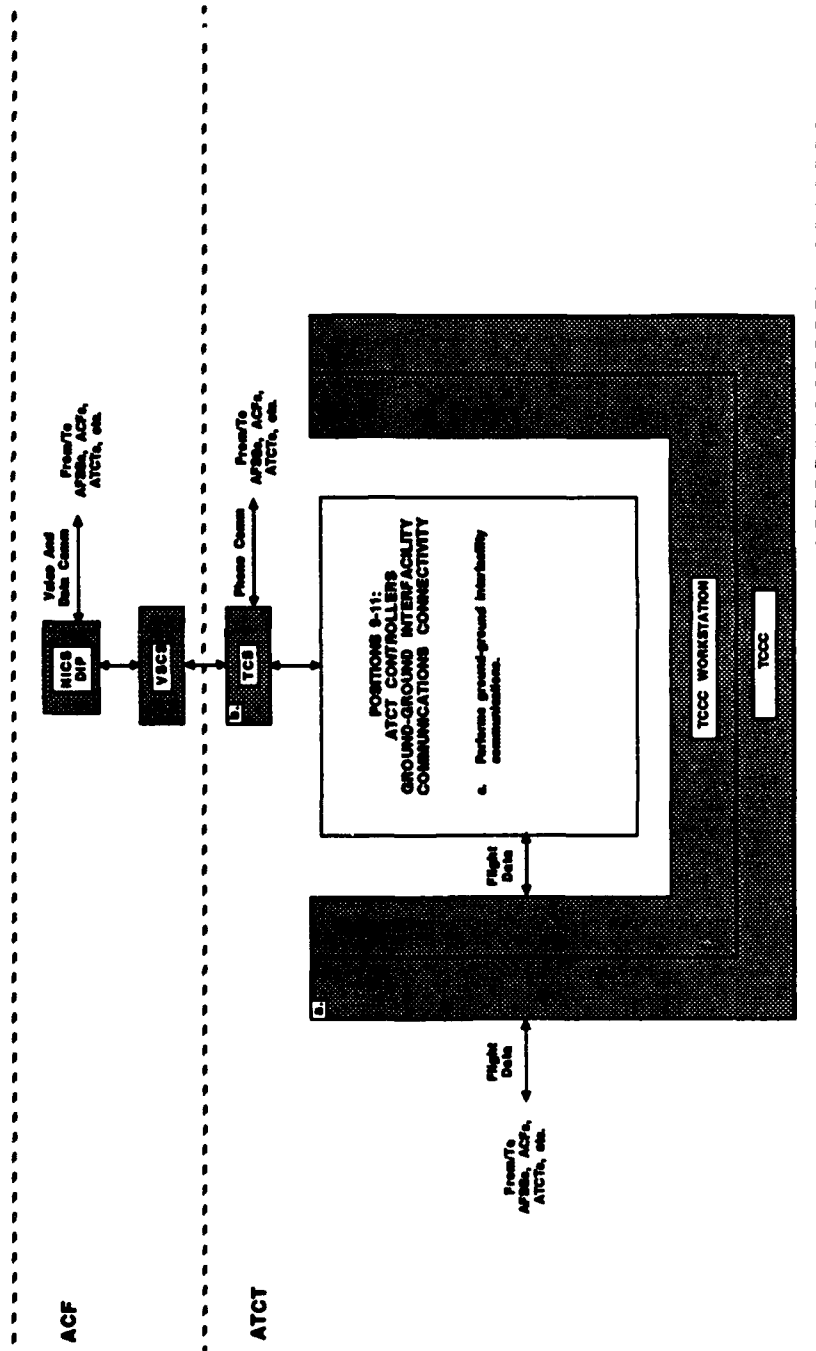

**FIGURE 2-5**  
**POSITIONS 9-11: ATCT CONTROLLERS**  
**OPERATIONAL FLOW DIAGRAM FOR**  
**GROUND-GROUND INTERFACILITY COMMUNICATIONS CONNECTIVITY**

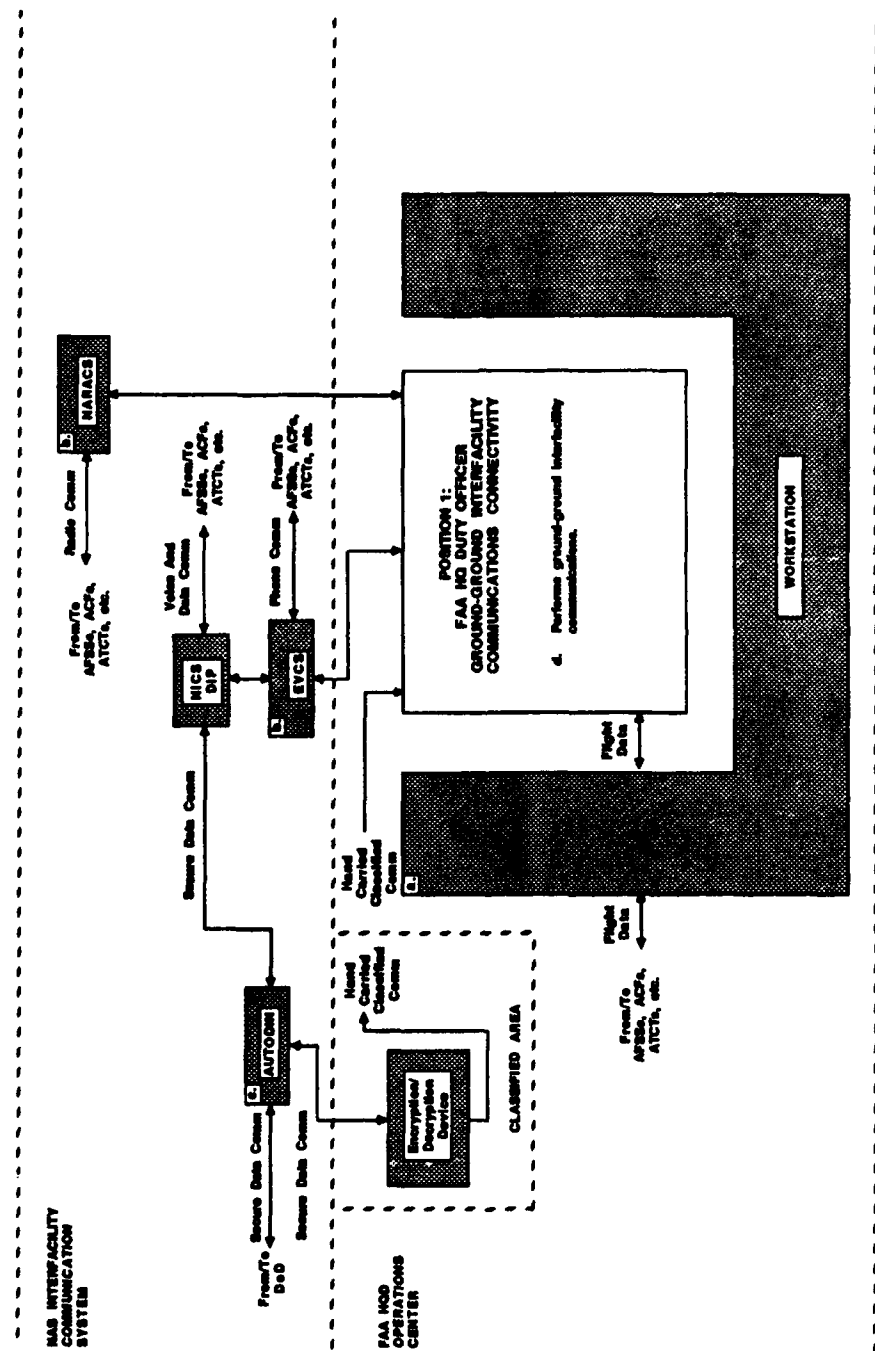

FIGURE 2-6  
 POSITION 1: OPERATIONS CENTER DUTY OFFICER  
 OPERATIONAL FLOW DIAGRAM FOR  
 GROUND-GROUND INTERFACILITY COMMUNICATIONS CONNECTIVITY

contains notification lists, access methods for communication lines and other similar types of support.

**NASSRS Requirement 3.6.2.A**

- b. Emergency Voice Communications System (EVCS). The FAA Headquarters Operations Center utilizes the EVCS to provide ground-ground interfacility and executive communication connectivity. The EVCS consists of a dedicated private telephone network and PABXs located at Headquarters, Regional and center offices, and ACFs. Direct hotlines are used to communicate with National Operations Centers at other DoD, Federal departments and agencies. AUTOVON access is provided for contact with DoD facilities. The National Radio Communications System (NARACS) also provides voice and data radio communication between FAA HQ, Regional and center Headquarters, and major ATC facilities. The non-emergency day-to-day NARACS mission provides communication and control support during normal NAS operations. The EVCS interfaces with commercial public switched networks, the FTS, and the military AUTOVON system.

**NASSRS Requirement 3.6.2.B**

- c. AUTODIN Secure Communications Between NAS and DoD Facilities. The FAA HQ Operations Center utilizes secure telephone units for secure voice communications with DoD facilities. The AUTODIN provides secure data communications for transmitting classified messages between DoD and the FAA HQ Operations Center.

**NASSRS Requirement 3.6.2.C**

- d. Perform Ground-Ground Interfacility Communications. FAA HQ Ops Center specialists utilize the EVCS to perform ground-ground communications with both NAS facilities and non-NAS facilities. The AUTODIN is used for secure data and for secure telephone units voice communications with DoD facilities.

**NASSRS Requirement 3.6.2.A, B, C**

**2.3.5 ATCCC Specialists (Positions 13 through 15)**

The Traffic Management Processor (TMP) is used to process flight data from other NAS facilities. ATCCC specialists utilize the Traffic Management Voice System (TMVS) to coordinate flight information with Traffic Management Coordinators (TMCs) in ACFs and ATCTs. This communication capability is available continuously to specialists and can be reconfigured to the operational needs of the specialist.

Figure 2-7 is an operational flow diagram describing the ground-ground communication connectivity interfaces provided to specialists in the ATCCC. Functions performed by the equipment and these specialists are lettered within each block and are described in the corresponding paragraphs below.

- a. Traffic Management Processor. Flight data is passed to the ATCCC from the TMP located at the FAA Technical Center. Data is passed between the TMP and non-NAS facilities such as airline dispatch offices, airline schedule vendors, DUAT service and pilots via telephone.

NASSRS Requirement 3.6.2.A

- b. Traffic Management Voice System (TMVS). The TMVS provides a communications control system configured for the ATCCC to provide rapid voice communication capability with NAS facilities, including the VSCS in ACFs, ICSS in AFSSs, and the TCS in ATCTs. The TMVS also accesses the DoD's AUTOVON system for communication with military facilities. The TMVS interfaces with federal telephone systems and dedicated phone lines outside the government systems. The TMVS interface enables ATCCC specialists to communicate with law enforcement organizations, other government agencies, and foreign ATC airline representatives.

NASSRS Requirement 3.6.2.B

- c. AUTODIN for Secure Communications. The AUTODIN terminal provides DoD/FAA interface with the capability of sending and receiving classified messages over secure communications lines. The AUTODIN system provides the DoD, FAA, Coast Guard, State Department, and certain other government departments and agencies with the means to exchange classified messages.

NASSRS Requirement 3.6.2.C

- d. Perform Ground-Ground Interfacility Communications. ATCCC specialists utilize both the TMP and the TMVS to perform ground-ground communications with other NAS facilities and non-NAS facilities. ATCCC specialists also utilize the AUTODIN for secure communications with DoD facilities.

NASSRS Requirement 3.6.2.A, B, C

#### 2.4 Correlation with Operational Requirements

Table 2-1 summarizes the correlation of the ground-ground communications connectivity operational requirements graph of NAS-SR-1000 with the paragraphs describing the communication functions being performed by specialists/controllers. All ground-ground communications paragraph numbers of NAS-SR-1000 are listed; paragraphs which are

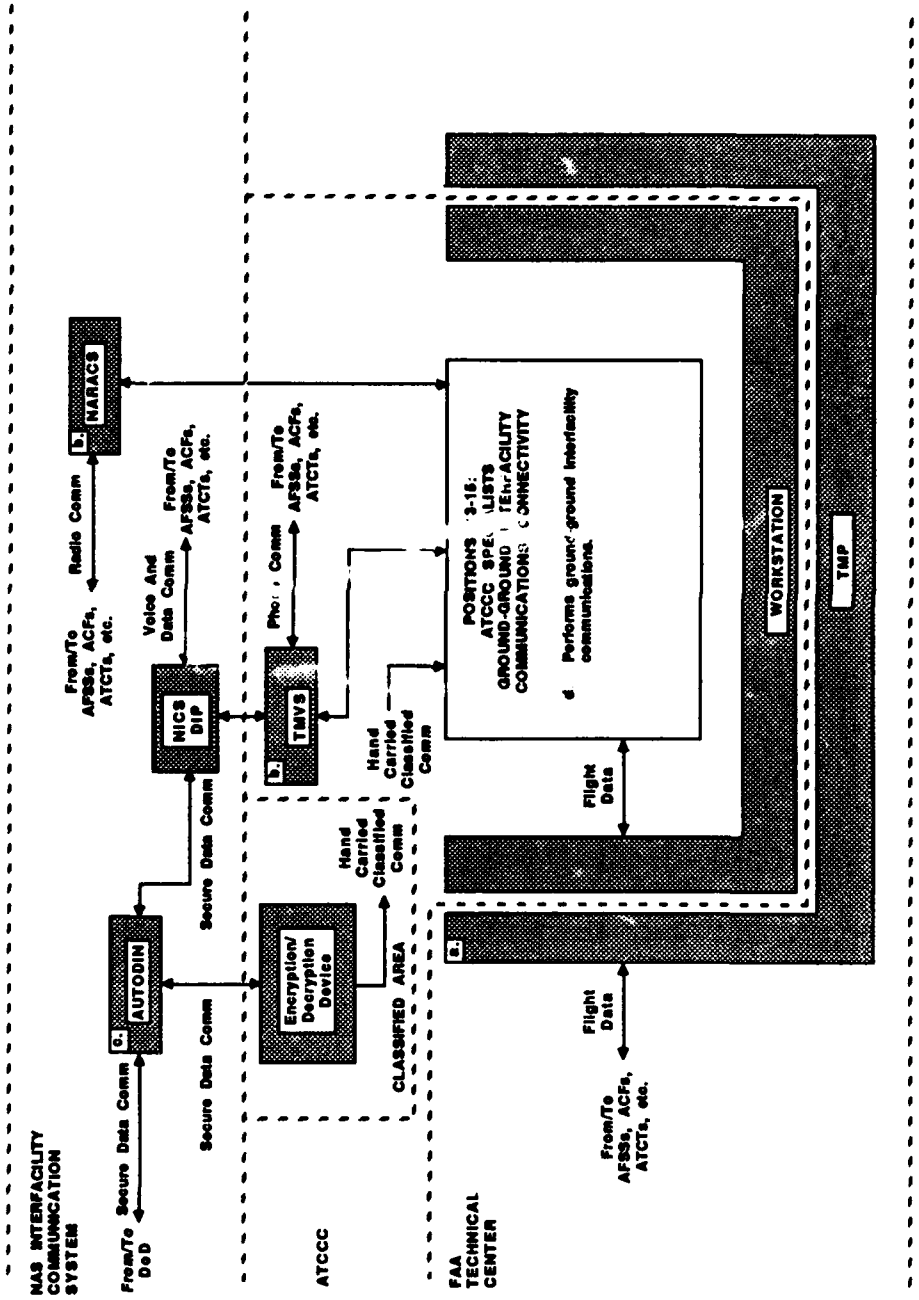

**FIGURE 2-7**  
**POSITIONS 13-15: ATCCC SPECIALISTS**  
**OPERATIONAL FLOW DIAGRAM FOR**  
**GROUND-GROUND INTERFACILITY COMMUNICATIONS CONNECTIVITY**

**TABLE 2-1  
GROUND-GROUND INTERFACILITY COMMUNICATIONS CONNECTIVITY  
OPERATIONAL REQUIREMENTS CORRELATION**

NAS FACILITIES	AFSS SPECIALISTS	ACF SPECIALISTS	ATCT SPECIALISTS	FAAHQ SPECIALISTS	ATCCC SPECIALISTS
	231a 231b 231c	232a 232b 232c 232d	233a 233b 233c	234a 234b 234c 234d	235a 235b 235c 235d
NAS-SR-1000 PARAGRAPH					
3.6.2 General	X	X	X	X	X
3.6.2.A Comm Between NAS Facilities	X	X	X	X	X
3.6.2.B Comm Between FAA & Non-NAS	X	X	X	X	X
3.6.2.C Secure Comm Between NAS & DoD		X		X	X

introductory in nature, do not state an explicit operational requirement, or which reference other portions of NAS-SR-1000 are indicated with a dash. The fact that a correlation is shown between a requirements paragraph and a paragraph describing the specialist/controller functions should not be construed as indicating that the requirement is completely fulfilled.

## 2.5 Operational Sequence

Operational sequence diagrams have been developed to illustrate the interactions of ground-ground communication connectivity between facilities. These diagrams are general in nature and no effort has been made to depict a specific situation.

### 2.5.1 Communications Between NAS and Non-NAS (Data) Sequence

Figure 2-8 describes one form of ground-ground communication connectivity involving the transfer of data from a non-NAS source to a NAS source. In this sequence a pilot can file his IFR flight plan from his home using his personal computer as a DUAT. This terminal allows the pilot to communicate with the DUAT service and file his flight plan (1). This information is forwarded over commercial phone lines to the DUAT service where the flight plan is formatted and processed (2). The DUAT service then forwards the IFR flight plan via the NICS to the ACCC (3). The ACCC forwards the flight plan to the appropriate facility, in this case an ATCT, via the NICS to the TCCC (4). The TCCC servicing the departure terminal airport holds the flight plan where, at the appropriate time, the Clearance Delivery Controller will transmit the clearance to the pilot.

### 2.5.2 Communications Between NAS Facilities (Data) Sequence

Figure 2-9 describes a ground-ground data communication sequence between NAS facilities. In this sequence a military base operations specialist wants to file a military training route activation with the FAA. The specialist sends the activation notification to the ACCC in the ACF from his workstation via the AUTODIN (1). The AUTODIN is connected to the NICS which forwards the information to the ACCC (2). The ACCC forwards the information to the appropriate controller's sector suite which alerts the controller (3). The ACCC also passes the information to the FSDPS via a Local Communications Network (LCN) within the ACF (4) which, in turn, forwards the information to the AFSS via the NICS (5) which alerts the specialist through his workstation. Concurrently, the ACCC forwards the information to the adjacent ACF's ACCC via the NICS (6) which accepts the information and forwards it to the appropriate controllers via their sector suites (7). This ACCC also forwards the activation information to the FSDPS within the ACF (8) which forwards the information to the AFSS specialist involved (9). This information is presented to the specialist through his workstation.

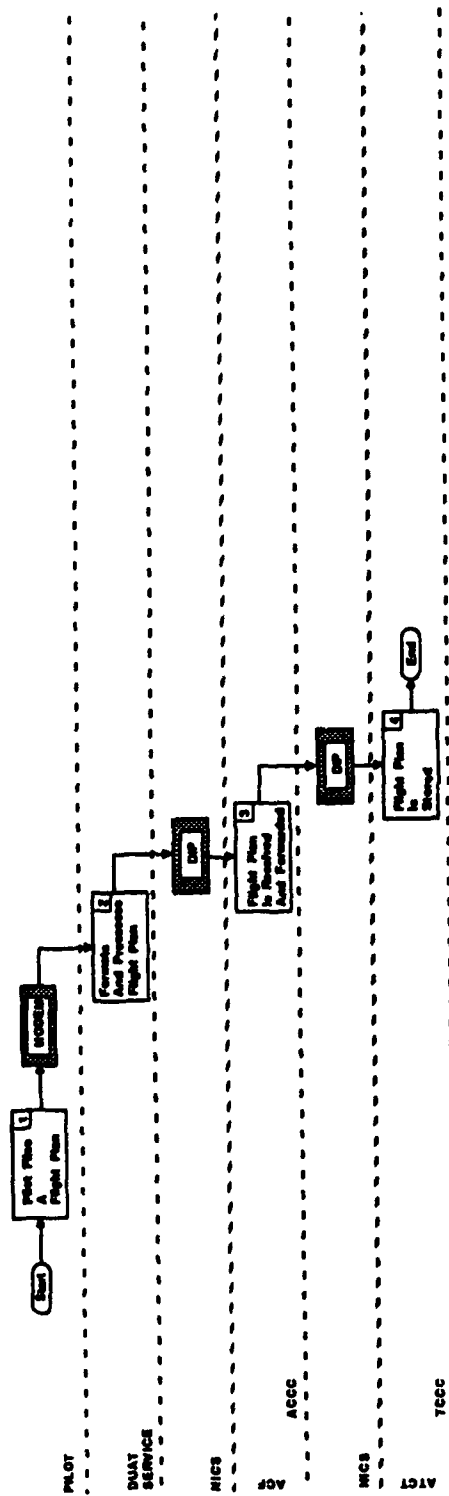

FIGURE 2-8  
 COMM BETWEEN NAS AND NON-NAS (DATA)  
 GROUND-GROUND INTERFACILITY COMMUNICATIONS CONNECTIVITY  
 OPERATIONAL SEQUENCE DIAGRAM

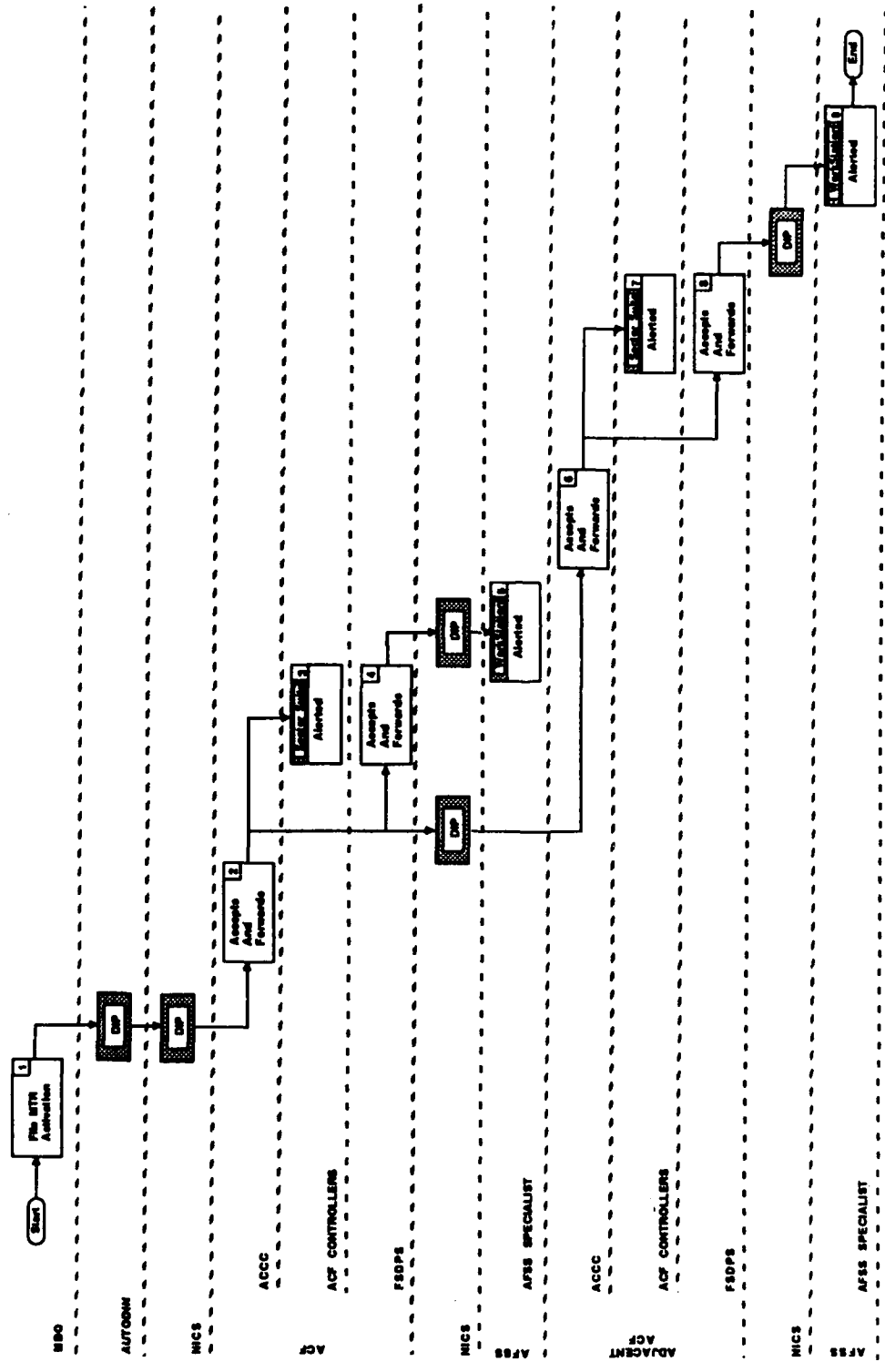

FIGURE 2-9  
 COMM BETWEEN NAS FACILITIES (DATA)  
 GROUND-GROUND INTERFACILITY COMMUNICATIONS CONNECTIVITY  
 OPERATIONAL SEQUENCE DIAGRAM

### 2.5.3 Communications Between NAS Facilities (Voice) Sequence

Figure 2-10 describes a ground-ground sequence involving voice communications between NAS facilities. For the purposes of describing the voice communications connectivity it is assumed that the following calls are made after the appropriate data messages are sent. In this sequence an ATCT reports that they must restrict traffic arriving at their airport due to an emergency. The tower specialist, using the TCS (1), notifies the approach controller at the ACF through his VSCS (2) to implement arrival restrictions. The tower controller then notifies the TMC at the ACF, again using the TCS to VSCS connection (3), of the problem. The TMC then notifies the TMS at the ATCCC via a VSCS to TMVS communication connection to inform him of the restrictions (4). The TMS specialist, using the TMVS, contacts the ACF controller on the VSCS and advises of the restrictions (5).

### 2.5.4 Secure Communications Between DoD and NAS Facilities Sequence

This sequence describes the transmission of classified messages from the DoD to NAS facilities over secure communication systems. Figure 2-11 portrays how a classified message (1) is encrypted (2) at the source and forwarded via the DoD's AUTODIN to the ATCCC where it is decrypted (3) and given to the TMS personnel (4). Simultaneously, the classified message is passed to the crypto equipment at the ACF (5) where it is decrypted and given to the TMC (6) and affected controller (7).

### 2.5.5 Communications Between NAS and Non-NAS Facilities (Voice)/FAA HQ Ops Sequence

Figure 2-12 describes voice communications between the FAA Headquarters Operations Center and non-NAS facilities. This sequence describes the events and voice communications interface between the Operations Center and other NAS and non-NAS facilities during an emergency situation. This sequence begins when an Area Manager at an ACF contacts the Regional Operations Center and makes an initial hijack report with the Regional Duty Officer through the VSCS at the ACF (1). The VSCS is connected to the EVCS at the Operations Center by the NICS. Once the Operations Center is notified, the Duty Officer initiates notification of key personnel at the FAA Headquarters Operations Center using the EVCS and commercial public switched telephone networks (2) via the NICS for affected ATC facilities (3), PABX for the involved air carrier operations center (4), and other appropriate agencies, in this case, the FBI (5). Once the telephone conference is established it remains in effect until no longer needed. Each party can freely talk and exchange information. As the event progresses, the Operations Center continues to exchange information with affected parties until the situation is resolved at which point the ATC facilities (8), the affected air carrier operations center (10), and other affected agencies terminate their participation (11).

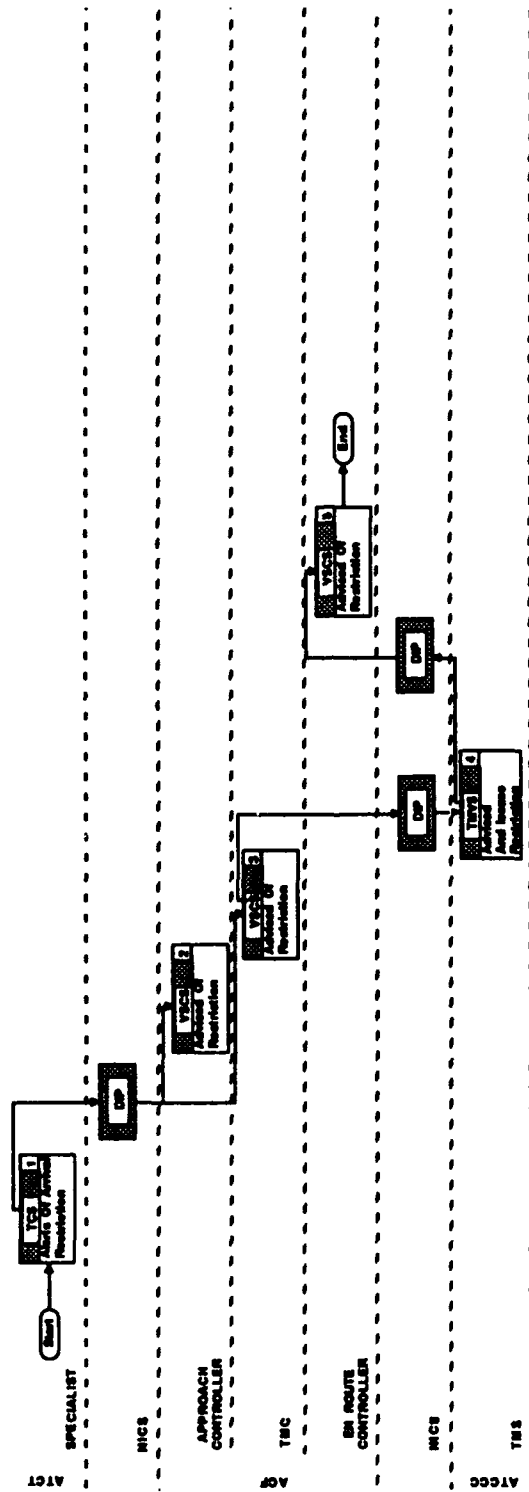
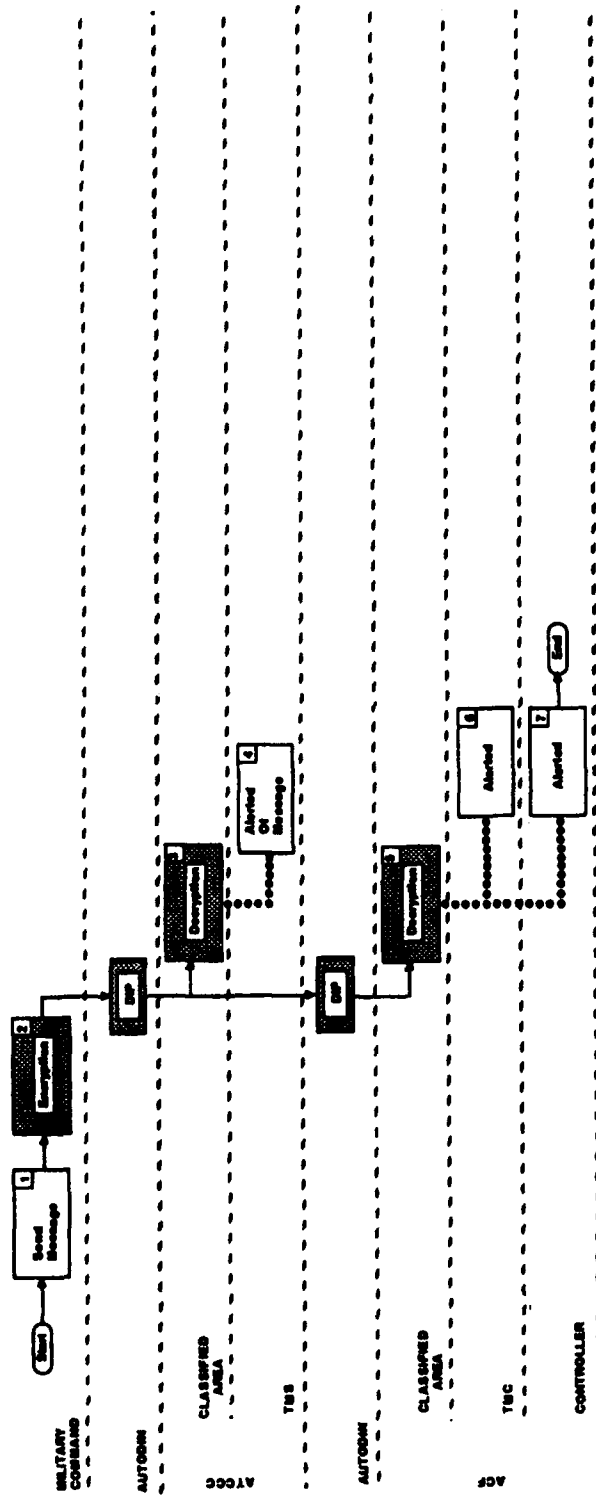

FIGURE 2-10  
 COMM BETWEEN NAS FACILITIES (VOICE)  
 GROUND-GROUND INTERFACILITY COMMUNICATIONS CONNECTIVITY  
 OPERATIONAL SEQUENCE DIAGRAM



KEY: oooooo Dotted line carries classified communication.

FIGURE 2-11  
 SECURE COMM BETWEEN DoD AND NAS FACILITIES  
 GROUND-GROUND INTERFACILITY COMMUNICATIONS CONNECTIVITY  
 OPERATIONAL SEQUENCE DIAGRAM

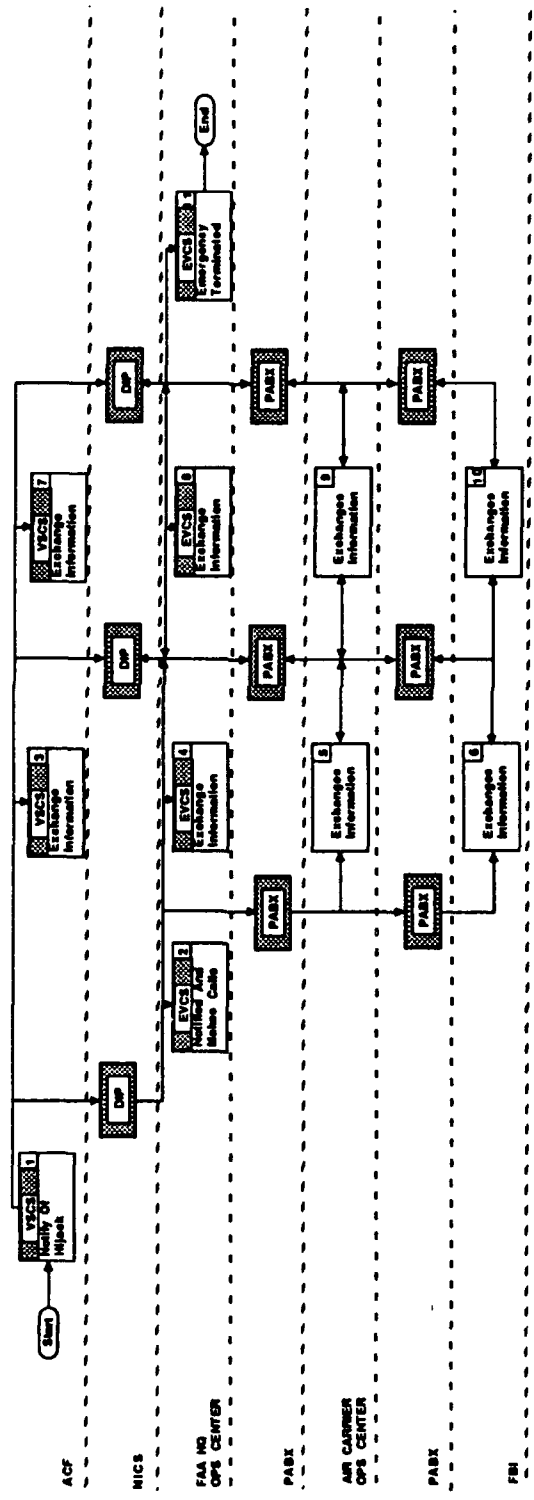

FIGURE 2-12  
 COMM BETWEEN NAS AND NON-NAS FACILITIES (VOICE)/ FAA HQ OPS  
 GROUND-GROUND INTERFACILITY COMMUNICATIONS CONNECTIVITY  
 OPERATIONAL SEQUENCE DIAGRAM

## 2.6 Operational Scenario

### 2.6.1 Communications Between NAS and Non-NAS (Data) Scenario

Figure 2-13 describes an operational scenario for ground-ground communications utilizing the DUAT service. It is similar to the operational sequence diagram in Figure 2-8, however, this scenario represents the interfaces between ground-ground communication systems for a specific case. This scenario assumes a pilot wants to file an IFR flight plan from Dulles Airport, Virginia to Burke Lakefront airport in Cleveland, Ohio using his personal computer. Since his computer terminal is configured with a modem and associated software to allow it to communicate with the DUAT service, it is referred to as a direct user access terminal (DUAT). The pilot of N101NH gains access to the DUAT service from his modem via commercial phone lines and files his flight plan (1). The DUAT service, formats, processes, and forwards the flight plan to the ACCC (2) at the ACF via the NICS. The ACCC forwards the flight plan to the TCCC at Dulles via the NICS (4). The TCCC will hold the flight plan in its database until the appropriate time for clearance delivery.

### 2.6.2 Communications Between NAS Facilities (Data) Scenario

In the second scenario Figure 2-14 presents an operational scenario for the exchange of data between NAS facilities. It is similar to the operational sequence design in Figure 2-9, however, this scenario represents the communication interfaces between NAS facilities for a specific case. In this scenario the military authority responsible for the military training route Instrument Route 514 forwards the activation times to the ACCC at the Denver ACF via the AUTODIN which interfaces with the NICS (1). The ACCC accepts the message and forwards the information (2) to the appropriate controllers through their sector suite (3). The ACCC also passes the activation to the FSDPS within the ACF (4) which forwards the message to the specialists at the Columbus AFSS. The Columbus specialists are alerted through their workstations (5). The Denver ACCC also alerts its adjacent facility, the Minneapolis ACF, via the NICS of the activation. The ACCC at Minneapolis accepts the message (6) and forwards it to the affected controllers (7) through their sector suite. The ACCC also passes the information to the FSDPS within the Minneapolis ACF (8). The FSDPS at Minneapolis ACF forwards the message to the specialist at the Huron AFSS via the NICS (9) which alerts the specialists through their workstations.

### 2.6.3 Communications Between NAS Facilities (Voice) Scenario

This operational scenario shows the ground-ground voice communications connectivity between NAS facilities. It is similar to the operational sequence diagram Figure 2-10; however this scenario portrays the communications connectivity for a specific situation. In Figure 2-15, an aircraft blows a tire on landing at Washington National Airport. Since the aircraft has stopped on the runway at midfield, arrival traffic must be delayed. The Tower Controller, using the TCS notifies

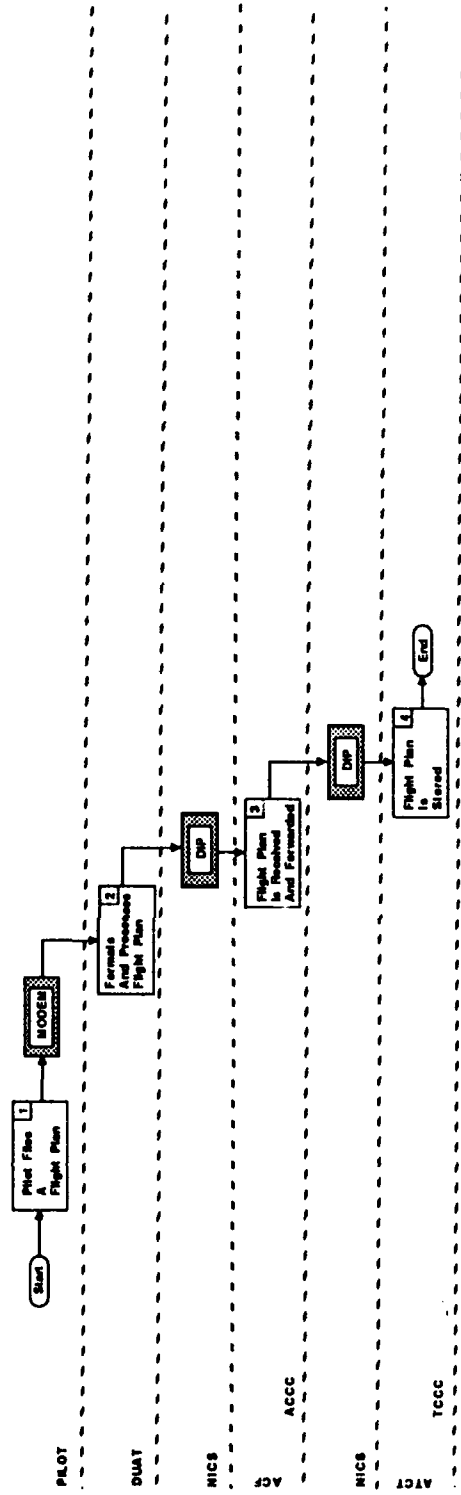

FIGURE 2-13  
 COMM BETWEEN NAS AND NON-NAS FACILITIES (DATA)  
 GROUND-GROUND INTERFACILITY COMMUNICATIONS CONNECTIVITY  
 OPERATIONAL SCENARIO

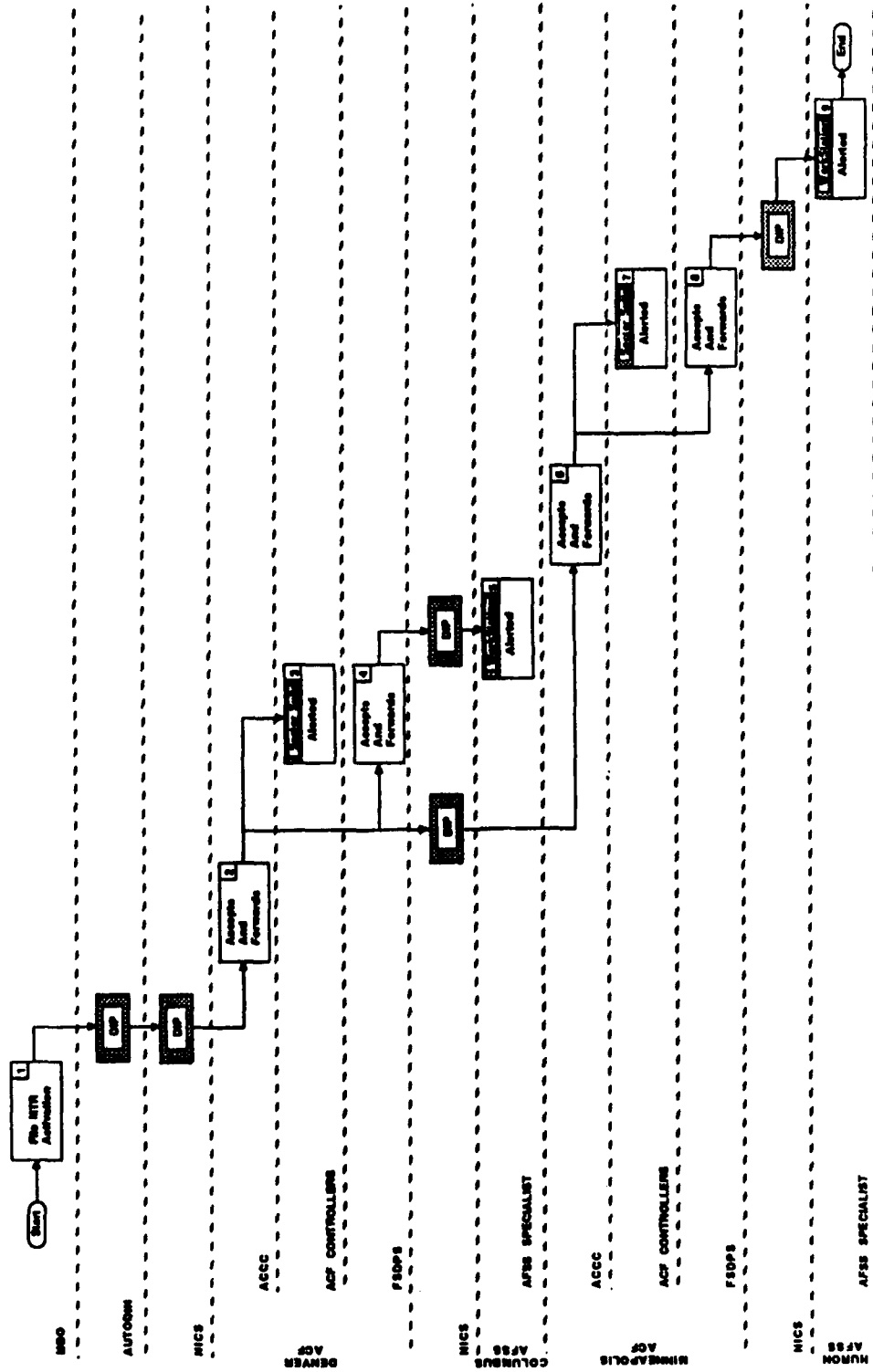

FIGURE 2-14  
 COMM BETWEEN NAS FACILITIES (DATA)  
 GROUND-GROUND INTERFACILITY COMMUNICATIONS CONNECTIVITY  
 OPERATIONAL SCENARIO

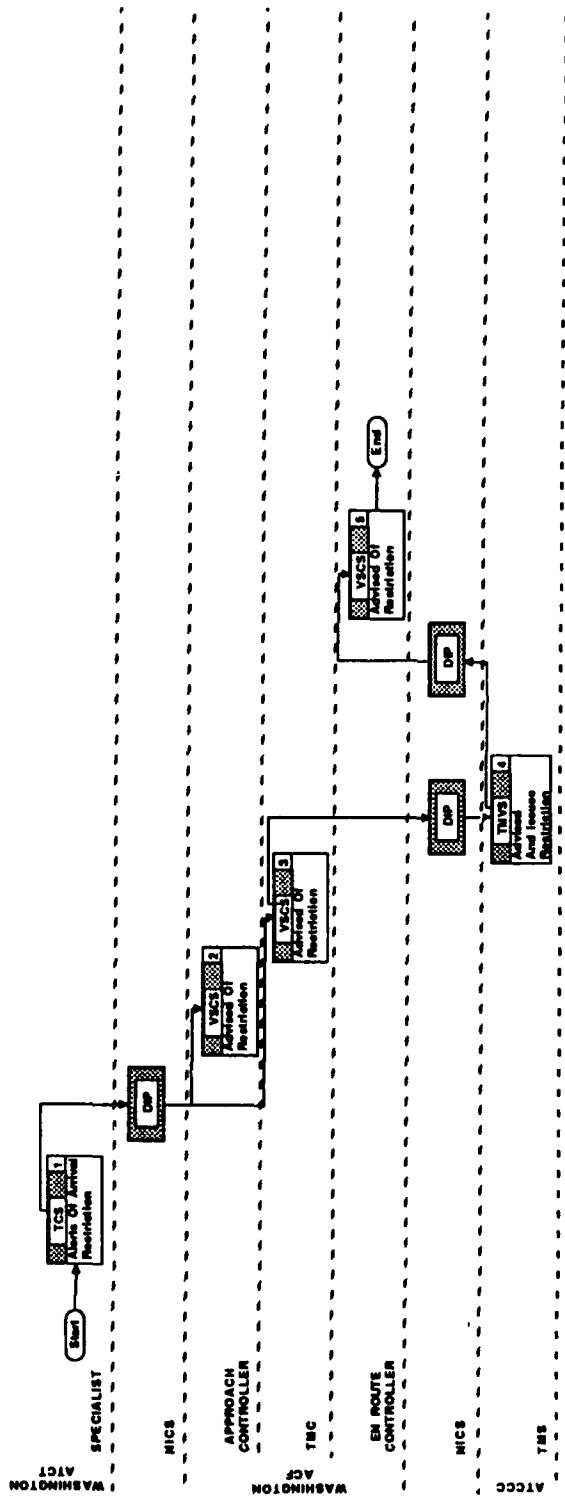

FIGURE 2-15  
 COMM BETWEEN NAS FACILITIES (VOICE)  
 GROUND-GROUND INTERFACILITY COMMUNICATIONS CONNECTIVITY  
 OPERATIONAL SCENARIO

the Washington ACF sector of the situation (1). The Arrival Controller at the IRONS LOW sector answers the Tower Controller using the VSCS (2) and receives the information. The Tower Controller then notifies the TMC via the VSCS of the arrival restrictions (3). The TMC in turn notifies the TMS at the ATCCC of the restriction. The TMS receives this voice call over the TMVS (4). The TMS using his TMVS, calls the En route Controller at the ACF through his VSCS (5) and advises him to restrict traffic into the approach controller's airspace.

#### 2.6.4 Secure Communications Between DoD and NAS Facilities Scenario

The next scenario describes how classified data is passed on a secure communication system between DoD and NAS facilities. In Figure 2-16, a specialist at the 4th Tactical Fighter Wing Base operations at Seymour-Johnson AFB, inputs a classified flight plan (1). The Flight plan is encrypted (2) and is transmitted via the AUTODIN. The flight plan is forwarded to the CFCF at the ATCCC where it is decrypted (3) and given to the TMS (4) for planning purposes. At the same time the flight plan is forwarded to the Washington ACF, also via the AUTODIN, where it is decrypted (5). The flight plan is then given to the TMC (6) and the controllers (7) affected.

#### 2.6.5 Communications between NAS and Non-NAS Facilities (Voice) FAA HQ Ops Center Scenario

This scenario (Figure 2-17) describes the ground-ground communications that take place during a hijack situation between the FAA Headquarters Operations Center and other NAS and non-NAS facilities. It is similar to the operational sequence diagram in Figure 2-12; however, this scenario shows more detail and represents the ground-ground communication interfaces between the facilities involved. This scenario begins when Eastern Airlines Flight 947 (EA 947), from Washington National en route to Miami, FL, notifies the Washington ACF of a hijack situation. The Area Manager from Washington ACF notifies the Operations Center using the VSCS voice (1). The Washington VSCS is interfaced to the NICS which is interfaced with the EVCS at the Operations Center. The Duty Officer at the Operations Center receives the call (2) and while the Washington ACF is still connected (3) he immediately notifies the Eastern Airlines Operations Center (5) through the PABX on commercial telephone lines. The FBI (6) is also notified through the PABX. The TMS at the ATCCC receives a call over the TVMS, which is interfaced with the NICS in case EA 947 needs a change in routing that will affect traffic flow (7). As each affected facility joins the telephone conference they are able to discuss the situation with each other. At this point the pilot of EA 947 informs the Washington ACF that the hijack situation has stabilized and requests to land at Raleigh-Durham Airport, NC. The Duty Officer at the Operations Center contacts the Raleigh-Durham ATCT supervisor, adds him to the telephone conference call, and briefs him as to the situation (8). As the situation continues, the Washington ACF (9), the Eastern Ops Center (11), the FBI (12), and the TMS at the ATCCC (13) continue to monitor the situation and provide information as necessary. When EA 947 lands

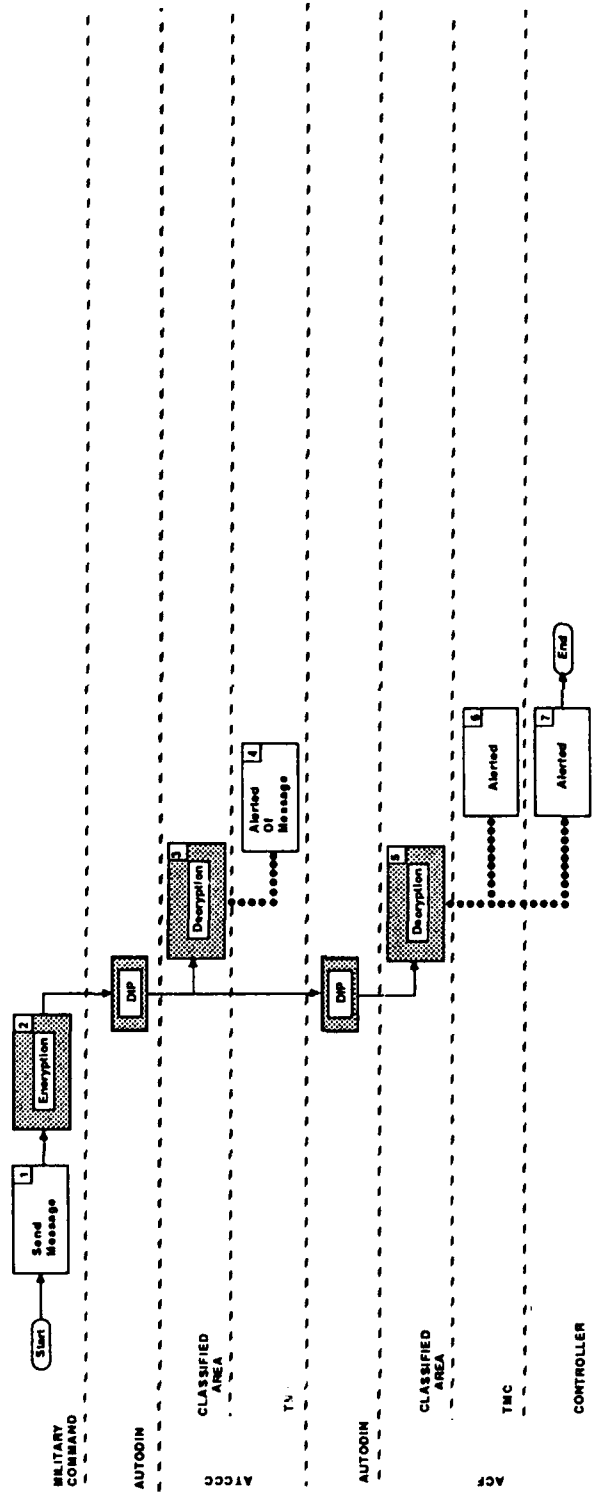

KEY: oooooo Denotes hand carried classified communication.

FIGURE 2-16  
 SECURE COMM BETWEEN DOD AND NAS FACILITIES  
 GROUND-GROUND INTERFACILITY COMMUNICATIONS CONNECTIVITY  
 OPERATIONAL SCENARIO

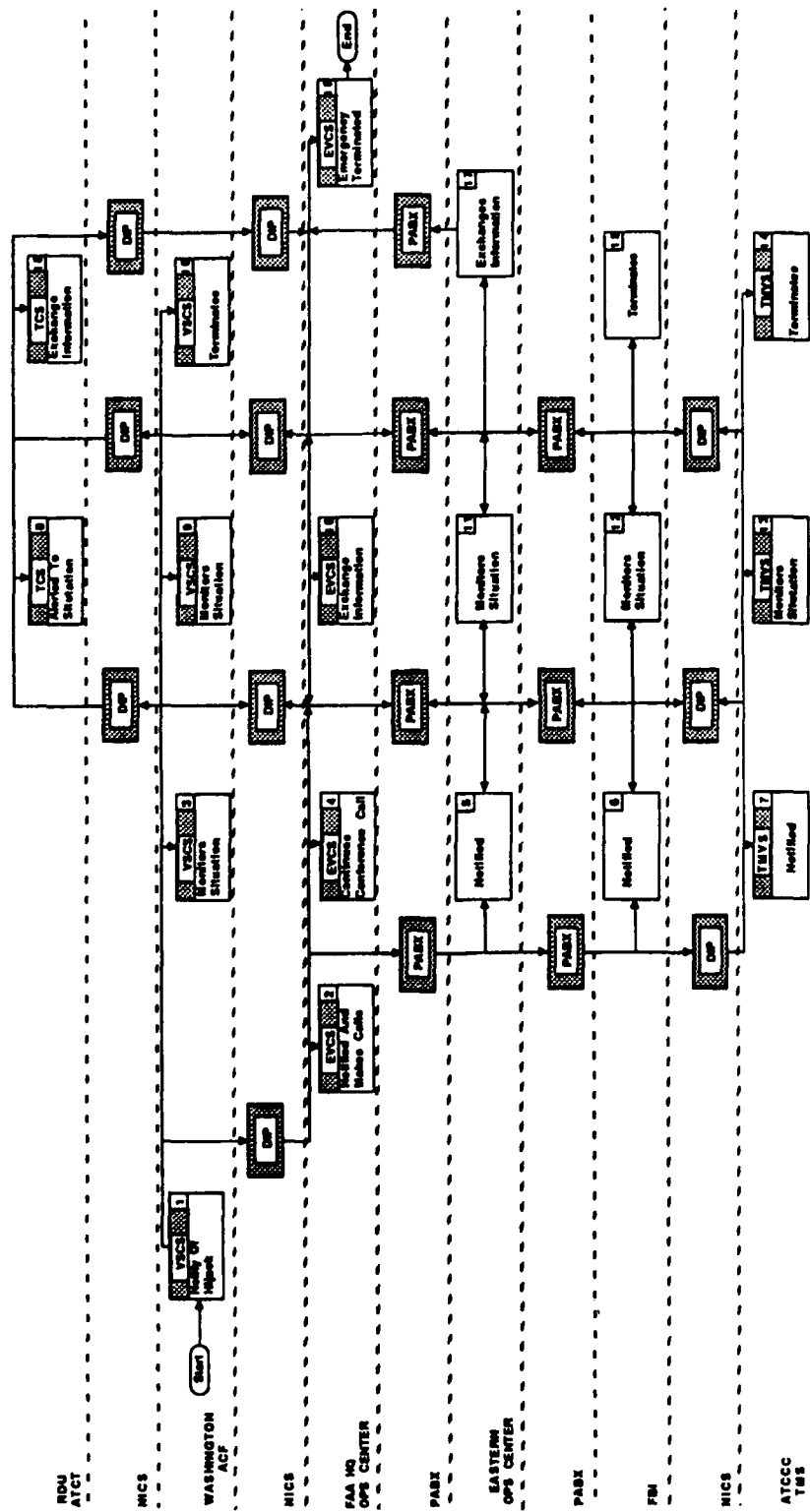

FIGURE 2-17  
 COMM BETWEEN NAS AND NON-NAS FACILITIES (FAA HQ OPS CENTER)  
 GROUND-GROUND INTERFACILITY COMMUNICATIONS CONNECTIVITY  
 OPERATIONAL SCENARIO

at Raleigh-Durham without incident the TMS at the ATCCC (14), the FBI (15), and the Washington ACF (16) terminate their connection while the Eastern Ops Center (17), the ATCT at Raleigh (18) and the Operations Center (19) continue the conference until the local authorities have terminated the emergency and the situation has concluded.

## REFERENCES

Federal Aviation Administration, Air Traffic Control, FAA Handbook 7110.65F, Current edition, Washington, D.C.

Federal Aviation Administration, Airman's Information Manual, Current edition, Washington, D.C.

Federal Aviation Administration, Flight Service Station Procedures, FAA Handbook 7110.10H, Current edition, Washington, D.C.

Federal Aviation Administration (June 1989), National Airspace System Level I Design Document, NAS-DD-1000, (Includes SCN-1 through SCN-18), Washington, D.C.

Federal Aviation Administration (September 1989), National Airspace System Plan, Facilities, Equipment and Associated Development, Washington, D.C.

Federal Aviation Administration (April 1989), National Airspace System System Requirements Specification, NAS-SR-1000, (Includes SCN-1 through SCN-9), Washington, D.C.

Federal Aviation Administration, Operations Center, FAA Order 1770.6A, Current edition, Washington, D.C.

Federal Aviation Administration, Traffic Management System, FAA Order 7210.47A, Current edition, Washington, D.C.

## GLOSSARY

**ACF BACKUP** - The capability to provide alternate control over the airspace of an ACF that has experienced a catastrophic failure.

**ADJACENT FACILITY** - A facility whose assigned airspace borders that of the facility being discussed. This applies to an ACF bordering another ACF and to an ATCT bordering an ACF.

**AIRCRAFT** - Device/s that are used or intended to be used for flight in the air; when used in air traffic control terminology may include the flight crew.

**AIRPORT TRAFFIC CONTROL TOWER (ATCT)** - A terminal facility that provides ATC services to aircraft operating in the vicinity of an airport or on the airport movement area. Authorizes aircraft to land or takeoff at the airport controlled by the tower or to transit the airport traffic area regardless of flight plan or weather conditions (IFR or VFR). A tower may also provide approach/departure control services.

**AIR ROUTE TRAFFIC CONTROL CENTER (ARTCC)** - A facility established to provide air traffic control service to aircraft principally during the en route phase of flight.

**AIR TRAFFIC CONTROL COMMAND CENTER (ATCCC)** - An air traffic service facility consisting of Central Flow Control Facility (CFCF), Central Altitude Reservation Function (CARF), Airport Reservation Office (ARO), and the ATC Contingency Communication and Post.

**ATCCC SPECIALIST** - Traffic management specialist resident at the Air Traffic Control Command Center (ATCCC) who coordinates with local traffic management specialists at ACFs and manages flow control operations.

**AREA CONTROL FACILITY (ACF)** - An ATC facility that provides both terminal and en route air traffic control services.

**AUTOMATED FLIGHT SERVICE STATION (AFSS)** - Air traffic facilities which provide pilot briefing, en route communications, and VFR search and rescue services; assist lost aircraft and aircraft in emergency situations; relay ATC clearances; originate Notices to Airmen; broadcast aviation weather and NAS information; receive and process IFR flight plans; and monitor NAVAIDS. In addition, at selected locations AFSSs provide En Route Flight Advisor Service (Flight Watch), take weather observations, issue airport advisories, and advise Customs and Immigration of transborder flights.

**CATASTROPHIC FAILURE** - The inability of an ACF to perform its operational responsibilities, regardless of cause, as determined by operational authorities.

**CLASSIFIED INFORMATION** - Official information, including foreign classified information, which has been designated as requiring protection in the interest of national security.

**DIRECT-ACCESS VOICE COMMUNICATIONS** - Means whereby a specialist can activate voice communications to a designated position in a different facility with a single action on a single device.

**DIRECTION FINDER (DF)** - A radio receiver equipped with a directional sensing antenna used to take bearings to obtain a fix on an aircraft or by a pilot plotting the bearing indications of his DF on two separately located ground-based transmitters.

**EMERGENCY** - A condition of being threatened by serious and/or imminent danger which requires immediate or timely assistance and action.

**EN ROUTE FLIGHT ADVISORY SERVICE/FLIGHT WATCH (EFAS)** - A service designed to provide timely weather information pertinent to the type of flight, intended route of flight, and altitude.

**FLIGHT PLAN** - Specified information relating to the intended flight of an aircraft that is filed orally or in writing with an ATC facility.

**FLOW CONTROL** - Measures taken to adjust the flow of traffic into a given airspace, along a given route, or bound for a given airport so as to ensure the most effective utilization of the airspace.

**IFR AIRCRAFT/IFR FLIGHT** - An aircraft conducting flight in accordance with instrument flight rules.

**INDIRECT-ACCESS VOICE COMMUNICATIONS** - Means whereby a specialist can establish voice communications with a designated position through multiple actions on one or more devices.

**INSTRUMENT FLIGHT RULES (IFR)** - Rules governing the procedures for conducting instrument flight. Also a term used by pilots and controllers to indicate type of flight plan.

**INTEGRATED COMMUNICATIONS SWITCHING SYSTEM (ICSS)** - A system which provides voice communications switching service for automated flight service stations (AFSSs). This system provides intercom, interphone, and radio communication switching services.

**NATIONAL RADIO COMMUNICATIONS SYSTEM (NARACS)** - A system which provides the minimum essential communication and control communications capability necessary to direct the management, operation, and the constitution of the NAS in support of FAA/DoT/DoD missions during a national, regional, or local emergency when normal communication on carrier telecommunications are interrupted.

**NATIONAL AIRSPACE SYSTEM (NAS)** - The NAS as used herein describes the FAA facilities, hardware, software, and the personnel who operate and maintain that equipment to provide services to the user.

**NOTICE TO AIRMEN (NOTAM)** - A notice containing information (not known sufficiently in advance to publicize by other means) concerning the establishment, condition, or change in any component (facility, service, or procedure of, or hazard in, the National Airspace System) the timely knowledge of which is essential to personnel concerned with flight operations.

**SPECIALIST** - The internal individual or group who provide service through the NAS (e.g., controllers, engineers, maintenance and management personnel).

**TERMINAL AREA** - A general term used to describe airspace in which approach/departure control service or airport traffic control service is provided.

**TOWER COMMUNICATIONS SYSTEM (TCS)** - A system which provides modern voice communications switch and control services for intercom, interphone, and air-ground voice connectivity for ATCTs.

**TRAFFIC MANAGEMENT COORDINATOR (TMC)** - A traffic management specialist resident at the ARTCC Traffic Management Unit (TMU) providing coordination between the national level central flow control function of the ATCCC and local ARTCC controllers.

**TRAFFIC MANAGEMENT SPECIALIST (TMS)** - A specialist resident at the Air Traffic Control Command Center (ATCCC) who coordinates between local traffic management specialists at ARTCCs/ACFs and manages flow control operations. See ATCCC description.

**TRAFFIC MANAGEMENT UNIT (TMU)** - A noncontrol, coordination position at an ARTCC connected to the Central Flow Control Function at the ATCCC and responsible for dissemination of flow control information at the local level.

**USER** - The external individual or group that receive services from the NAS (e.g., Pilot, Air Carrier, General Aviation, Military, Law Enforcement Agencies).

**VOICE SWITCHING AND CONTROL SYSTEM (VSCS)** - A system which provides voice communications services and performs the intercom, interphone, and air-ground voice connectivity and control function needed for air traffic control operations in ARTCCs and ACFs.

ACRONYMS/ABBREVIATIONS

<u>ACRONYM</u>	<u>MEANING</u>
ACCC	Area Control Computer Complex
ACF	Area Control Facility
ADO	Airline Dispatch Office
AFSS	Automated Flight Service Station
ARINC	Aeronautical Radio Incorporated
ARO	Airport Reservation Office
ATC	Air Traffic Control
ATCCC	Air Traffic Control Command Center
ATCT	Airport Traffic Control Tower
AUTODIN	Automatic Digital Network
AUTOVON	Automatic Voice Switching Network
CARF	Central Altitude Reservation Function
CFCF	Central Flow Control Function
COMCEN	Communications Center
CONUS	Continental United States
CWP	Central Weather Processor
DDD	Direct Distance Dialing
DIP	Drop/Insert Point
DUAT	Direct User Access Terminal
EFAS	En Route Flight Advisory Service
ETN	Electronic Tandem Network
EVCS	Emergency Voice Communication System
FBO	Fixed Base Operator
FSAS	Flight Service Automation System
FSDPS	Flight Service Data Processing System
FSS	Flight Service Station
FTS	Federal Telecommunications System
IC	Intercom
ICSS	Integrated Communication Switching System
IFR	Instrument Flight Rules
IP	Interphone
MBO	Military Base Operations
NADIN	National Data Interchange Network
NAS	National Airspace System
NARACS	National Radio Communications System
NAVAIDS	Navigation Aids
NCS	National Communication System
NICS	NAS Interfacility Communications System
PABX	Private Automatic Branch Exchange

ACRONYM

MEANING

RCE	Radio Control Equipment
RML	Radar Microwave Link
TCCC	Tower Control Computer Complex
TCS	Tower Communication System
TMC	Traffic Management Coordinator
TMP	Traffic Management Processor
TMS	Traffic Management System
TMVS	Traffic Management Voice Switch
VFR	Visual Flight Rules
VSCS	Voice Switching and Control System
WMSC	Weather Message Switching Center