

DTIC FILE COPY

UNITED STATES AIR FORCE

AD-A222 680

OCCUPATIONAL SURVEY REPORT

DTIC ELECTE
JUN 14 1990
S B D
Co

ANTENNA/CABLE SYSTEMS
PROJECT/MAINTENANCE ACTION
CAREER LADDER

AFSC 361X0

AFPT 90-361-866

MAY 1990

**OCCUPATIONAL ANALYSIS PROGRAM
USAF OCCUPATIONAL MEASUREMENT CENTER
AIR TRAINING COMMAND
RANDOLPH AFB, TEXAS 78150-5000**

APPROVED FOR PUBLIC RELEASE; DISTRIBUTION UNLIMITED

90 06 13 008

DISTRIBUTION FOR
AFSC 361X0 OSR AND SUPPORTING DOCUMENTS

	<u>OSR</u>	<u>ANL</u> <u>EXT</u>	<u>TNG</u> <u>EXT</u>	<u>JOB</u> <u>INV</u>
AFMPC/DPMRPQ1	2			
AFMPC/DPMRAD5	1			
ARMY OCCUPATIONAL SURVEY BRANCH	1			
CCAF/AYX	1			
DEFENSE TECHNICAL INFORMATION CENTER	2			
DET 4, USAFOMC (SHEPPARD AFB TX)	1	1	1	1
AFHRL/MODS	2	1m	1m	1
AFHRL/ID	1	1m	1m/1h	1
HQ AFCC/DPATO	3		3	
HQ AFCC/LGMK	2		2	
HQ AFCC/TTGT	1		1	
HQ AFISC/DAP	2			
HQ ATC/TTOK	2		1	
HQ ESC/DPTE	3		3	
HQ ESC/TTGT	1		1	
HQ USAF/LEYA	1		1	
HQ USAF/DPPE	1			
NODAC	1			
3700 TCHTW/TTOK (SHEPPARD AFB TX)	6	2h	6	2
3700 TCHTW/TTS (SHEPPARD AFB TX)	1		1	
USAFOMC/OMDQ	1			
USAFOMC/OMYXL	10	2m	2m/10h	10
USMC (CODE TE-310)	1			
1872 SCHS/TU (AFCC) (KEESLER AFB MS)	2	1m	1m/2h	
3507 ACS/DPKI	1			

m = microfiche only
h = hard copy only

TABLE OF CONTENTS

	PAGE NUMBER
PREFACE	iii
SUMMARY OF RESULTS.	iv
INTRODUCTION.	1
Background	1
SURVEY METHODOLOGY.	1
Inventory Development.	1
Survey Administration.	2
Survey Sample.	3
Task Factor Administration	3
SPECIALTY JOBS.	6
Overview of Specialty Jobs	7
Group Descriptions	7
Comparisons of Specialty Jobs.	12
Comparison of Current Survey to Previous Survey Findings	12
ANALYSIS OF DAFSC GROUPS.	13
Skill Level Descriptions	13
Summary.	18
ANALYSIS OF AFR 39-1 SPECIALTY DESCRIPTIONS	18
TRAINING ANALYSIS	18
First-Enlistment Personnel	21
Training Emphasis and Task Difficulty Data	21
Specialty Training Standard (STS).	30
Plan of Instruction (POI).	32
Electronics Principles (EP).	36
ANALYSIS OF MAJOR COMMANDS (MAJCOM)	36
ANALYSIS OF CONUS VERSUS OVERSEAS GROUPS.	40
JOB SATISFACTION ANALYSIS	40
IMPLICATIONS.	42
APPENDIX A.	46

Distribution For	
GRA&I	<input checked="" type="checkbox"/>
TAB	<input type="checkbox"/>
Unannounced	<input type="checkbox"/>
Confidential	<input type="checkbox"/>



By _____	
Distribution/	
Availability Codes	
Dist	Avail and/or Special
A-1	

PREFACE

This report presents the results of a detailed Air Force Occupational Survey of the Antenna/Cable Systems Project/Maintenance Action career ladder (AFSC 361X0). Authority for conducting occupational surveys is contained in AFR 35-2. Computer products upon which this report is based are available for the use of operations and training officials.

The survey instrument was developed by Captain Marlon Gardley, Inventory Development Specialist, with computer programming support furnished by Master Sergeant Cornelia Wharton. Ms Tamme Lambert provided administrative support. Mr Robert L. Alton, Occupational Analyst, analyzed the data and wrote the final report. This report has been reviewed and approved by Lieutenant Colonel Charles D. Gorman, Chief, Airman Analysis Branch, Occupational Analysis Division, USAF Occupational Measurement Center (USAFOMC).

Copies of this report are distributed to Air Staff sections, major commands, and other interested training and management personnel. Additional copies are available upon request to the USAF Occupational Measurement Center, Attention: Chief, Occupational Analysis Division (OMY), Randolph AFB, Texas 78150-5000 (AUTOVON 487-6623).

BOBBY P. TINDELL, Colonel, USAF
Commander
USAF Occupational Measurement
Center

JOSEPH S. TARTELL
Chief, Occupational Analysis Division
USAF Occupational Measurement
Center

SUMMARY OF RESULTS

1. Survey Coverage: The Antenna/Cable Systems Project/Maintenance Action career ladder was surveyed to obtain current data for use in determining whether current ABR course design is adequately preparing 361X0 personnel for their first assignment. Survey results are based on responses from 460 respondents (57 percent of the total assigned population). All major using commands are well represented in the survey sample.
2. Specialty Jobs: Three clusters and three independent jobs were identified in the sample. Two clusters and one of the independent jobs were directly involved in the performance of various technical duties and tasks of the career ladder. The remaining cluster and independent jobs were oriented toward supervisory, managerial, quality assurance, and training activities.
3. Career Ladder Progression: The 3- and 5-skill level jobs were highly technical, with very little responsibility for supervision or management. At the 7-skill level, supervisory, managerial, training, and quality assurance functions are the dominant characteristics of the job.
4. AFR 39-1 Specialty Descriptions: All descriptions accurately depict the nature of the respective jobs.
5. Training Analysis: The Specialty Training Standard (STS) is generally supported by survey data; however, there are a number of elements requiring review because of questionable proficiency coding or low percentages of the target populations performing matched tasks. The Plan of Instruction (POI) has three units of instruction that contain criterion objectives which require review due to low percentages of first-term airmen performing tasks trained.
6. Job Satisfaction: The high percentages of positive responses to the questions pertaining to job interest, use of talents and training, as well as reenlistment intentions, reflect a career ladder where personnel appear to be well satisfied with their jobs.
7. Implications: Generally, the training program appears to be operating effectively. There are, however, elements of the STS and POI that warrant an in-depth review by training personnel and subject-matter experts to determine appropriate adjustments to these documents.

OCCUPATIONAL SURVEY REPORT
ANTENNA/CABLE SYSTEMS PROJECT/MAINTENANCE ACTION CAREER LADDER
(AFSC 361X0)

INTRODUCTION

This is a report of an occupational survey of the Antenna/Cable Systems Project/Maintenance Action career ladder completed by the Occupational Analysis Division, USAF Occupational Measurement Center. This survey was requested by the 3700th Technical Training Wing, Sheppard Technical Training Center, to obtain current task and equipment data for use in evaluating current training programs. The last survey results pertaining to this career ladder were published in May 1986.

Background

As described in AFR 39-1 Specialty Descriptions, dated February 1988, personnel in this career ladder are responsible for installing, removing, and maintaining various antenna systems, as well as installing, testing, and maintaining aerial, underground, and buried cable supporting systems for command, control, communications, and computers.

Primary entry into the career ladder is from Basic Military Training School (BMTS) through a Category A 9-week and 4-day formal training course conducted at Sheppard AFB, Texas. Current ABR training includes electrical fundamentals; pole climbing; installation and maintenance of antenna systems; and installation and maintenance of aerial, underground, and buried cable systems. Entry into the career ladder currently requires an Armed Services Vocational Aptitude Battery (ASVAB) Mechanical score of 51.

SURVEY METHODOLOGY

Inventory Development

The data collection instrument for this occupational survey was USAF Job Inventory AFPT 90-361-866, dated May 1989. A tentative task list was prepared after reviewing pertinent career ladder publications and directives, tasks from the previous survey instrument, and data from the last Occupational Survey Report (OSR). The preliminary task list was refined and validated through personal interviews with 46 subject-matter experts (selected to cover a wide variety of 361X0 career ladder functions) at the following locations:

APPROVED FOR PUBLIC RELEASE; DISTRIBUTION UNLIMITED

<u>BASE</u>	<u>REASON FOR VISIT</u>
McClellan AFB CA	Engineering/Electronics Installation (EI) unit supporting PACAF operations
Vandenberg AFB CA	Tasks in support of a missile test unit
Kelly AFB TX	Major EI unit and Electronic Security Command (ESC)
Patrick AFB FL	Tasks in support of space center activities and hardened antennas
MacDill AFB FL	Centralized Antenna Team and antenna maintenance activities
Andrews AFB MD	Large maintenance operation with considerable activity pertaining to rotatable log periodic (RLP) antennas
Griffiss AFB NY	EI unit supporting USAFE operations
Eglin AFB FL	Tasks involving fiber optic transmission lines and hardware
Keesler AFB MS	EI unit and involvement with fiber optics
Sheppard AFB TX	Location of ABR technical training course

The resulting job inventory contained a comprehensive listing of 620 tasks grouped under 21 duty headings and a background section requesting such information as grade, duty title, types of antennas installed or maintained, towers installed or maintained, equipment used or operated, as well as tools or test equipment used.

Survey Administration

From May through October 1989, Consolidated Base Personnel Offices (CBPO) in operational units worldwide administered the inventory to military job incumbents holding DAFSCs 36130, 36150, and 36170. Job incumbents were selected from a computer-generated mailing list obtained from personnel data tapes maintained by the Air Force Human Resources Laboratory (AFHRL).

Each individual who completed the inventory first completed an identification and biographical information section and then checked each task performed in his or her current job. After checking all tasks performed, each member then rated each of these tasks on a 9-point scale, showing relative time spent on that task, as compared to all other tasks checked. The ratings ranged from 1 (very small amount time spent) through 5 (about average time spent) to 9 (very large amount spent).

To determine relative time spent for each task checked by a respondent, all of the incumbent's ratings are assumed to account for 100 percent of his or her time spent on the job and are summed. Each task rating is then divided by the total task ratings and multiplied by 100 to provide a relative percentage of time for each task. This procedure provides a basis for comparing tasks in terms of both percent members performing and average percent time spent.

Survey Sample

Personnel were selected to participate in this survey so as to ensure an accurate representation across major commands (MAJCOM) and military paygrade groups. All eligible DAFSC 36130, 36150, and 36170 personnel were mailed survey booklets. Table 1 reflects the percentage distribution, by MAJCOM, of assigned AFSC 361X0 personnel as of May 1989. The 460 respondents in the final sample represent 57 percent of the total assigned personnel, and 65 percent of the total personnel surveyed. Table 2 reflects the paygrade distribution for 361X0 personnel. As reflected in these tables, the survey sample is an excellent representation of the career ladder population.

Task Factor Administration

In addition to completing the job inventory, selected senior 36170 personnel also completed a second booklet rendering judgements on task training emphasis (TE) or task difficulty (TD). The TE and TD booklets were processed separately from the job inventories. The information gained from these task factor data is used in various analyses and is a valuable part of the training decision process.

Task Difficulty (TD). Each individual completing a TD booklet was asked to rate all of the tasks on a 9-point scale (from extremely low to extremely high) as to the relative difficulty of each task in the inventory. Difficulty is defined as the length of time required by the average incumbent to learn to do the task. Task difficulty data were independently collected from 40 7-skill level personnel stationed worldwide. Interrater reliability was determined to be adequate, which reflects a satisfactory agreement among raters. Ratings were standardized so tasks have an average difficulty of 5.00, with a standard deviation of 1.00. The resulting data yield essentially a rank ordering of tasks indicating the degree of difficulty for each task in the inventory.

TABLE 1
COMMAND DISTRIBUTION OF 361X0 PERSONNEL

<u>COMMAND</u>	<u>PERCENT OF ASSIGNED</u>	<u>PERCENT OF SAMPLE</u>
AFCC	91	91
ESC	4	3
AF ELEMENTS (EUROPE)	3	3
ATC	<u>2</u>	<u>3</u>
TOTAL	100	100

Total Assigned* - 807

Total Surveyed** - 704

Total in Survey Sample - 460

Percent of Assigned in Sample - 57%

Percent of Surveyed in Sample - 65%

* Assigned strength as of May 1989

** Excludes personnel in PCS, student, or hospital status, or with less than 6 weeks on the job

TABLE 2
PAYGRADE DISTRIBUTION OF SURVEY SAMPLE

<u>GRADE</u>	<u>PERCENT OF ASSIGNED*</u>	<u>PERCENT OF SAMPLE</u>
AIRMAN	30	32
E-4	31	29
E-5	22	23
E-6	10	10
E-7	7	6
E-8	**	**

* Assigned strength as of May 1989
** Less than .5 percent

Training Emphasis (TE). Individuals completing TE booklets were asked to rate tasks on a 10-point scale (from no training required to extremely high amount of training required). Training emphasis is a rating of which tasks require structured training for first-term personnel. Structured training is defined as training provided at resident technical schools, field training detachments (FTD), mobile training teams (MTT), formal OJT, or any other organized training method. Training emphasis data were independently collected from 45 experienced 7-skill level personnel stationed worldwide. The interrater reliability for these raters was adequate, indicating there was satisfactory agreement among raters as to which tasks required some form of structured training and which did not. In this specialty, tasks have an average TE rating of 2.93; tasks considered high in training emphasis have ratings of 4.56 and above. As was discussed in the Task Difficulty (TD) section above, TE rating data may also be used to rank order tasks indicating those tasks which senior NCOs in the field consider the most important for the first-term airman to know.

When used in conjunction with the primary criterion of percent members performing, TD and TE ratings can provide insight into first-term personnel training requirements. Such insights may suggest a need for lengthening or shortening portions of instruction supporting AFS entry-level jobs.

SPECIALTY JOBS (Career Ladder Structure)

A USAF occupational analysis begins with an examination of the career ladder structure. The structure of jobs within the Antenna/Cable Systems Project/Maintenance Action career ladder was examined on the basis of similarity of tasks performed and the percent of time spent ratings provided by job incumbents, independent of other specialty background factors.

Each individual in the sample performs a set of tasks called a job. For the purpose of organizing individual jobs into similar units of work, an automated job clustering program is used. This hierarchical grouping program is a basic part of the Comprehensive Occupational Data Analysis Program (CODAP) system for job analysis. Each individual job description (all the tasks performed by that individual and the relative amount of time spent on those tasks) in the sample is compared to every other job description in terms of tasks performed and the relative amount of time spent on each task in the job inventory. The automated system is designed to locate the two job descriptions with the most similar tasks and percent time ratings and combine them to form a composite job description. In successive stages, new members are added to initial groups or new groups are formed based on the similarity of tasks performed and similar time ratings in the individual job descriptions.

The basic identifying group used in the hierarchical job structuring process is the Job. When there is a substantial degree of similarity between Jobs, they are grouped together and identified as a Cluster. Specialized Jobs too dissimilar to fit within a Cluster are labeled Independent Jobs (IJ). The job structure information resulting from this grouping process (the various jobs within the career ladder) can be used to evaluate the accuracy of career

ladder documents (AFR 39-1 Specialty Descriptions and Specialty Training Standards) and to gain a better understanding of current utilization patterns. The above terminology will be used in the discussion of the 361X0 career ladder structure.

Overview of Specialty Jobs

Structure analysis identified three clusters and three independent jobs within the survey sample. Based on task similarity and relative time spent, the division of jobs performed by 361X0 personnel is illustrated in Figure 1, and a listing of those clusters and independent jobs is provided below. The stage (ST) number shown beside each title is a reference to computer printed information; the number of personnel in each group (N) is also shown.

- I. ENGINEERING/ELECTRONICS INSTALLATION (EI) CLUSTER (ST0041, N=230)
- II. ANTENNA MAINTENANCE CLUSTER (ST0039, N=122)
- III. PARABOLIC ANTENNA INSTALLATION (IJ) (ST0074, N=6)
- IV. SUPERVISION CLUSTER (ST0030, N=31)
- V. QUALITY ASSURANCE (IJ) (ST0029, N=5)
- VI. TRAINING (IJ) (ST0066, N=7)

The respondents forming these groups account for 87 percent of the survey sample. The remaining 13 percent were performing tasks or series of tasks which did not group with any of the defined jobs. Job titles given by respondents which were representative of these personnel included Engineering Technician, Resource Manager, and Workload Controller.

Group Descriptions

The following paragraphs contain brief descriptions of the clusters and independent jobs identified through the career ladder structure analysis. Selected background data for these groups are provided in Table 3. Representative tasks for all the groups are contained in Appendix A.

I. ENGINEERING/ELECTRONICS INSTALLATION (EI) CLUSTER (ST0041). The 230 airmen forming this group (50 percent of the survey sample and the largest group identified) are primarily responsible for the initial installation of cable and antenna systems which support communications and computer operations. With the majority of the members working as members of an EI Team

AFSC 361XO SPECIALTY JOBS (N= 460)

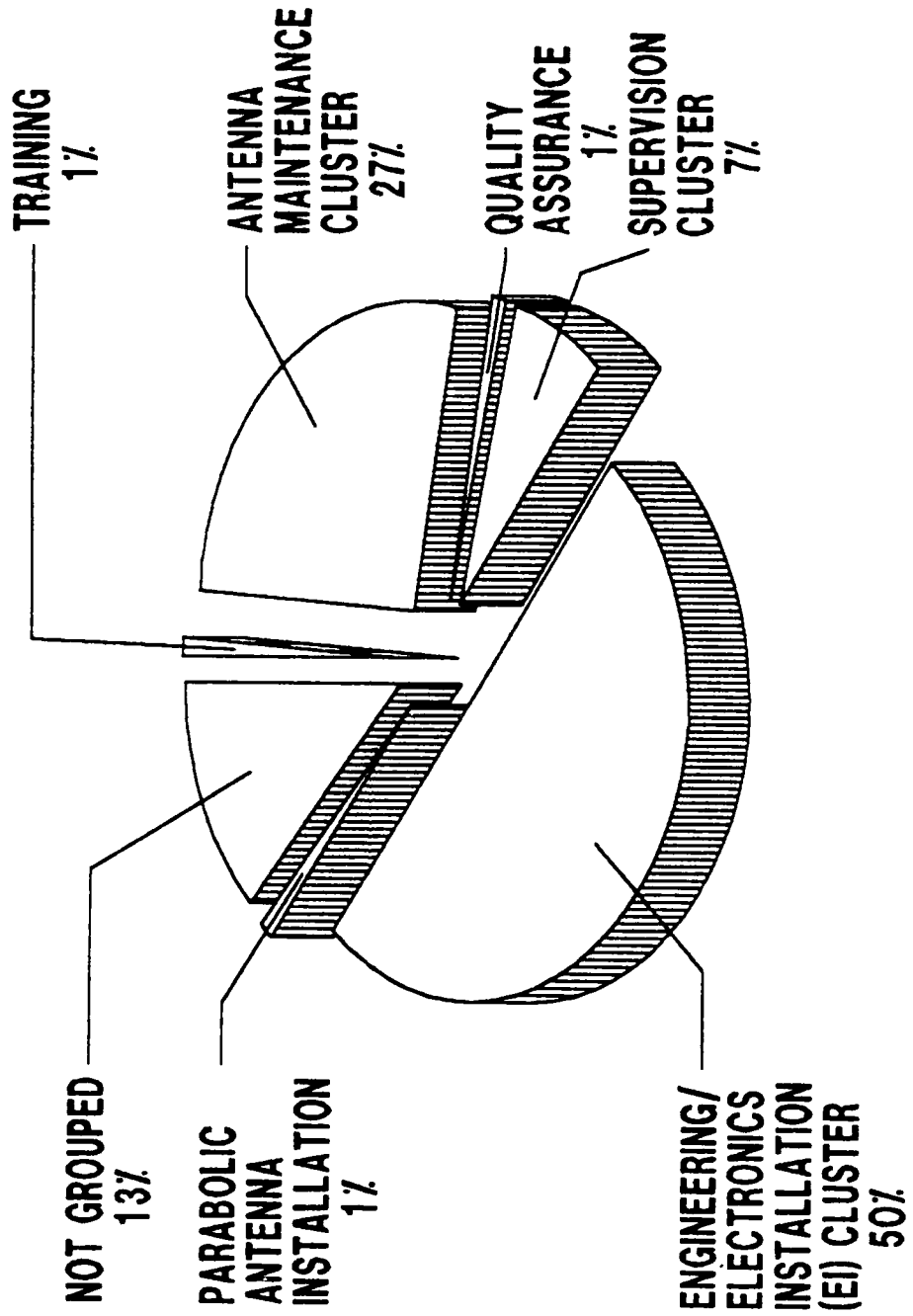

FIGURE 1

TABLE 3

SELECTED BACKGROUND DATA FOR SPECIALTY JOB CLUSTERS AND INDEPENDENT JOBS

	ENGINEERING/ ELECTRONICS INSTALLATION (EI) CLUSTER	ANTENNA MAINTENANCE CLUSTER	PARABOLIC ANTENNA INSTALLATION	SUPERVISION CLUSTER	QUALITY ASSURANCE	TRAINING
NUMBER IN GROUP	230	122	6	31	5	7
PERCENT OF TOTAL SAMPLE	50%	27%	1%	7%	1%	1%
PERCENT IN CONUS	73%	39%	33%	65%	40%	100%

DAFSC DISTRIBUTION:

36130	7%	11%	33%	0%	0%	0%
36150	78%	68%	50%	23%	20%	71%
36170	15%	21%	17%	77%	80%	29%

PREDOMINANT GRADE(S)
AVERAGE MONTHS IN CAREER FIELD
AVERAGE MONTHS IN SERVICE
PERCENT IN FIRST ENLISTMENT

	E-3/E-4	E-4/E-5	E-3/E-4	E-6/E-7	E-7	E-5
AVERAGE MONTHS IN CAREER FIELD	58	77	53	164	188	111
AVERAGE MONTHS IN SERVICE	64	84	55	191	198	126
PERCENT IN FIRST ENLISTMENT	58%	44%	67%	3%	0%	0%

PERCENT SUPERVISING
AVERAGE NUMBER TASKS PERFORMED

PERCENT SUPERVISING	20%	40%	17%	77%	0%	0%
AVERAGE NUMBER TASKS PERFORMED	151	116	85	76	49	9

(which can also include personnel with related AFSCs), they perform a rather broad job (an average of 151 tasks--largest of all groups identified) that may also require involvement in major system modifications. The job is highly technical, with 87 percent of their relative duty time devoted to tasks pertaining to installation of various cable and antenna systems, as well as general construction activities. Representing one of the two major technical functions of the career ladder, the scope of the job ranges from digging ditches to electronics troubleshooting. Typical tasks include:

- performing initial installation of buried telephone cables
- framing poles with hardware accessories, such as crossarms
- digging or backfilling trenches
- performing initial installation of VHF or UHF antennas
- cleaning or rodding ducts
- performing initial installation of guys

With an average of over 4 years time in the career field, 78 percent of the airmen in this cluster report holding a 5-skill level DAFSC, and reflect predominant grades of E-3 and E-4. Of the four job variations identified within the cluster, one group (32 respondents) was notable in that members, while still performing predominantly technical tasks, were devoting 41 percent of their relative duty time to general supervisory, managerial, training, and Team Chief tasks.

II. ANTENNA MAINTENANCE CLUSTER ST0039). Comprising 27 percent of the survey sample, these 122 respondents also perform a very technical job (81 percent of their relative duty time), but one that is dominated by tasks involving routine day-to-day maintenance of antenna systems and the corresponding cables and support structures. Sixty-one percent of these airmen are assigned in overseas locations, and the majority report serving in base communications units, or assignment to Centralized Antenna Teams (CAT) or NATO Support Activities units. Some of the most representative antenna systems maintenance tasks common to this group are:

- removing or replacing flexible coaxial cable connectors
- performing corrosion control on antenna systems
- maintaining antenna components, such as radiators, passive reflectors, or rotor controls
- inspecting antenna or line support hardware
- maintaining RLP antenna systems
- removing or replacing VHF or UHF antennas

Although two job variations were found in this cluster, the primary distinction between them was the greater amount of supervisory activity reflected for one of the groups. Personnel in this job are somewhat more experienced than the previously discussed cluster of EI personnel, with an average of over 6 years time in the career field, and reflecting an average grade of E-4 and E-5

III. PARABOLIC ANTENNA INSTALLATION (ST0074). This small group of six airmen perform a job that is characterized by the concentration of relative job time (76 percent) spent on duties pertaining to the installation of parabolic antennas, waveguides, and the appropriate general antenna support and cable related tasks. Only 44 tasks account for over 50 percent of their relative duty time. Examples of tasks reflecting the specialized nature of the group's job include:

- performing initial installation of flexible waveguides
- performing initial installation of preassembled parabolic antennas
- operating or aligning parabolic antennas
- loading, unloading, or transporting waveguides
- performing initial installation of protective shields on parabolic antennas

The least experienced of any group identified in the career ladder structure (53 months time in the career field), 67 percent of these respondents are still in their first enlistment.

IV. SUPERVISION CLUSTER (ST0030). Spending 87 percent of their relative job time performing tasks pertaining to general supervisory, managerial, training, and team chief duties, 77 percent of these 31 incumbents (7 percent of the survey sample) report direct supervisory responsibilities. With essentially no time spent on basic technical task performance, representative tasks displaying the supervisory nature of the job include:

- writing APRs
- determining work priorities
- conducting OJT
- establishing performance standards for subordinates
- planning briefings
- interpreting policies, directives, or procedures for subordinates

Seventy-seven percent of these group members report holding a 7-skill level DAFSC (94 percent reflect either a 7- or 9-skill level PAFSC) and average over 13 years time in the career field.

V. QUALITY ASSURANCE (ST0029). This small group of five NCOs form a job that is characterized by the predominance of time spent on quality control or quality assurance tasks dealing with inspection, evaluation, or review. With only 17 tasks accounting for over 50 percent of their relative job time, typical tasks performed include:

- writing inspection reports
- reviewing or inspecting communications electronics facility records (CEFR)
- performing final inspections
- performing in progress inspections
- preparing or processing quality assurance (QA) or quality control (QC) forms

The most highly experienced group identified in the career ladder structure analysis (over 15 years time in the career field), 80 percent of these NCOs report holding a 7-skill level DAFSC, and the predominant grade is E-7.

VI. TRAINING (ST0066). Six of the NCOs forming this job are assigned to the technical training center and the seventh member reports a duty assignment at the AFCC EI Academy. With over 9 years time in the career field, these NCOs responded to some technically-oriented tasks performed while demonstrating field techniques or procedures, as well as those tasks normally performed in an academic classroom or laboratory teaching environment. Examples of the training tasks defining this group include:

- scoring tests
- writing test questions
- counseling trainees on training progress
- administering tests

Comparisons of Specialty Jobs

Three clusters and three independent jobs were identified in the career ladder structure analysis. Two clusters and one of the independent jobs were directly involved in performing the various technical duties and tasks of the career ladder. The remaining cluster and independent jobs were oriented toward supervisory, managerial, quality assurance, and training activities.

There are clearly two distinct technical functions within the career ladder (EI and antenna maintenance). Career ladder managers must continue to be aware of the differences between these functions, and assure that career ladder personnel are allowed to move between them during their careers. This movement will broaden their experience base and avoid locking them into only one facet of the total career ladder responsibilities.

Comparison of Current Group Descriptions to Previous Survey Findings

The results of the specialty job analysis were compared to those of Occupational Survey Report (OSR) AFPT 90-361-247, CABLE AND ANTENNA SYSTEMS INSTALLATION/MAINTENANCE CAREER LADDER, dated May 1986. After reviewing the tasks performed within the jobs identified in 1986, it was determined that those groups could be linked with similar task performances by 1990 sample

groups (see Table 4). The few differences noted between comparable groups during the review can be attributed to modifications in the task list or to the analysis approach used.

Based on this review, the current sample respondents were found to be performing the types of jobs identified in 1986, thus displaying a relatively stable career ladder over time.

ANALYSIS OF DAFSC GROUPS

An analysis of DAFSC groups, in conjunction with the analysis of the career ladder structure, is an important part of each occupational survey. The DAFSC analysis identifies differences in tasks performed at the various skill levels. This information may then be used to evaluate how well career ladder documents, such as AFR 39-1 Specialty Descriptions and the Specialty Training Standard (STS), reflect what career ladder personnel are actually doing in the field.

A comparison of the duty and task performance between DAFSCs 36130 and 36150 indicated that, while there are some minor differences, by and large, the jobs they perform are essentially the same. Therefore, they will be discussed as a combined group in this report. Nine-skill and CEM Code personnel in the 361XX career field were not surveyed and will not be discussed.

The distribution of skill-level groups across the career ladder jobs is displayed in Table 5, while Table 6 offers another perspective by displaying the relative percent time spent on each duty across the skill-level groups. A typical pattern of progression is present, with personnel spending more of their relative time on duties involving supervisory, managerial, training, team chief, and quality assurance tasks (see Table 6, Duties A, B, C, D, F, and G) as they move upward to the 7-skill level. It is also obvious, though, that 7-skill level personnel are still involved with technical task performance, as will be pointed out in the specific skill-level group discussions below.

Skill Level Descriptions

DAFSCs 36130/36150. The 345 airmen in the 3- and 5-skill level group (representing 75 percent of the survey sample) performed an average of 117 tasks, with 83 tasks accounting for over 50 percent of their job time. Performing a highly technical job, 86 percent of their relative duty time is devoted to tasks covering initial installation of cable and antenna systems, as well as day-to-day routine maintenance of the those systems. They report involvement with a wide range of antennas (such as, parabolic, UHF, VHF, rotatable log periodic (RLP), and rhombic), as well as aerial, buried, and underground cable systems. As shown in Table 5, 86 percent of these personnel are represented in the three technically-oriented jobs. Table 7 displays tasks representative of this group's work, while Table 9 displays those tasks which most clearly differentiate the 3-/5-skill level and 7-skill level groups.

TABLE 4
 JOB SPECIALTY COMPARISONS BETWEEN CURRENT AND 1986 SURVEYS

<u>CURRENT SURVEY (N=460)</u>	<u>PERCENT OF SAMPLE</u>	<u>1986 SURVEY (N=612)</u>	<u>PERCENT OF SAMPLE</u>
ENGINEERING/ELECTRONICS INSTALLATION (EI) CLUSTER	50	ENGINEERING INSTALLATION (EI) PERSONNEL CLUSTER	38
ANTENNA MAINTENANCE CLUSTER	27	RLP ANTENNA INSTALLERS	4
		ANTENNA MAINTENANCE PERSONNEL CLUSTER	19
		HARDENED ANTENNA MAINTENANCE PERSONNEL	4
		ANTENNA SUPPORT MAINTENANCE PERSONNEL	3
PARABOLIC ANTENNA INSTALLATION	1	PARABOLIC ANTENNA INSTALLERS	2
SUPERVISION CLUSTER	7	MANAGEMENT AND STAFF PERSONNEL CLUSTER	12
QUALITY ASSURANCE	1		
TRAINING	1	TRAINING PERSONNEL	1

TABLE 5
DISTRIBUTION OF DAFSC GROUP MEMBERS ACROSS SPECIALTY JOBS

<u>SPECIALTY JOBS</u>	<u>DAFSC 36130/36150</u> <u>(N=345)</u>		<u>DAFSC 36170</u> <u>(N=115)</u>	
	<u>NUMBER</u>	<u>PERCENT</u>	<u>NUMBER</u>	<u>PERCENT</u>
I. ENGINEERING/ELECTRONICS INSTALLATION (EI) CLUSTER (N=230)	195	57%	35	30%
II. ANTENNA MAINTENANCE CLUSTER (N=122)	96	28%	26	23%
III. PARABOLIC ANTENNA INSTALLATION (N=6)	5	1%	1	1%
IV. SUPERVISION CLUSTER (N=31)	7	2%	24	21%
V. QUALITY ASSURANCE (N=5)	1	*	4	3%
VI. TRAINING (N=7)	5	1%	2	2%
NOT GROUPED	36	10%	23	20%

* Less than .5 percent

TABLE 6

AVERAGE PERCENT TIME SPENT PERFORMING DUTIES BY DAFSC GROUPS

DUTIES	DAFSC	DAFSC
	36130/ 36150 (N=345)	36170 (N=115)
A ORGANIZING AND PLANNING	3	13
B DIRECTING AND IMPLEMENTING	2	9
C EVALUATING AND INSPECTING	1	10
D TRAINING	4	12
E PERFORMING JOINT TASK FORCE WIRE SECTION TASKS	*	*
F PERFORMING QUALITY ASSURANCE OR CONTROL TASKS	*	3
G PERFORMING TEAM CHIEF TASKS	3	11
H PERFORMING GENERAL CONSTRUCTION TASKS	25	11
I INSTALLING AND MAINTAINING ANTENNA AND CABLE SUPPORT STRUCTURES	16	8
J PERFORMING GENERAL CABLE INSTALLATION AND MAINTENANCE TASKS	11	5
K INSTALLING AND MAINTAINING AERIAL TELEPHONE OR COAXIAL CABLES	2	1
L INSTALLING AND MAINTAINING BURIED TELEPHONE OR COAXIAL CABLES	6	2
M INSTALLING AND MAINTAINING UNDERGROUND COAXIAL OR TELEPHONE CABLES	5	2
N INSTALLING AND MAINTAINING FIBER OPTIC CABLES	1	1
O PERFORMING GENERAL ANTENNA INSTALLATION AND MAINTENANCE TASKS	6	4
P INSTALLING AND MAINTAINING WIRE ANTENNAS	2	1
Q INSTALLING AND MAINTAINING PARABOLIC ANTENNAS	2	1
R INSTALLING AND MAINTAINING RADOMES	1	1
S INSTALLING AND MAINTAINING WAVEGUIDES	4	2
T INSTALLING AND MAINTAINING ROTATABLE LOG PERIODIC (RLP) ANTENNAS	5	3
U INSTALLING AND MAINTAINING HARDENED ANTENNAS	1	*

* Less than .5 percent

TABLE 7
 REPRESENTATIVE TASKS PERFORMED BY
 36130/36150 PERSONNEL
 (N=345)

TASKS	PERCENT MEMBERS PERFORMING
H200 CLIMB POLES OR TOWERS	91
H238 TIE KNOTS IN FIBER ROPES	86
H241 WORK ALOFT ON METAL STRUCTURES	85
H197 BACKFILL TRENCHES MANUALLY	81
H208 DIG TRENCHES BY HAND	79
H220 PERFORM CONSTRUCTION HAND SIGNALS	79
H242 WORK ALOFT ON WOOD STRUCTURES	72
H207 FABRICATE ROLLED EYE SPLICES	71
H228 PERFORM OPERATOR MAINTENANCE ON VEHICLES	71
J321 LOAD, UNLOAD, OR TRANSPORT CABLE REELS	68
J349 TROUBLESHOOT CABLE USING MULTIMETERS	67
L390 LOCATE BURIED CABLES	67
H199 CLEAN OR ROD DUCTS	66
H198 BACKFILL TRENCHES MECHANICALLY	65
H204 DIG TRENCHES USING POWER EQUIPMENT, SUCH AS BACKHOES/ TRENCHERS	63
I314 TEST MANHOLE FOR COMBUSTIBLE AND TOXIC GASES AND OXYGEN DEFICIENCY	62
M443 PULL IN UNDERGROUND CABLES USING VEHICLES	61
O463 IDENTIFY OR TAG ANTENNAS	59
L399 PERFORM INITIAL INSTALLATION OF BURIED CABLE USING OPEN TRENCH METHOD	58
I253 FABRICATE GUYS	56
I272 MEASURE STRAND TENSION USING CAM-LEVER DYNOMETERS	56
O479 PLUMB ANTENNA SYSTEMS USING TRANSIT METHOD	55
J339 REMOVE OR REPLACE FLEXIBLE COAXIAL CABLE CONNECTORS	52
T559 INSPECT RLP ANTENNA SYSTEMS	51

Average number of tasks performed - 117

DAFSC 36170. Seven-skill level personnel, representing 25 percent of the survey sample, perform a job which is mostly supervisory in nature. Group members perform an average of 117 tasks, with 83 accounting for over 50 percent of their time. With 60 percent reporting supervisory responsibilities, these NCOs devote 54 percent of their relative duty time to supervisory, managerial, training, and team chief functions, and an additional 3 percent to quality assurance tasks. Although these incumbents are oriented toward supervision and management functions (see representative tasks in Table 8), many are still involved in technical installation and maintenance activities as well. This technical involvement is also reflected in Table 5, which shows that only 26 percent of these skill-level group members are found in the supervisory and staff-type jobs (SUPERVISION CLUSTER; QUALITY ASSURANCE; and TRAINING). The range of the job is reflected by the fact that 37 percent of the group still dig post holes using power equipment, and 41 percent indicate they backfill trenches manually.

Summary

Distinctions between skill level groups are evident, with personnel at the 3- and 5-skill levels spending the vast majority of their job time performing technical tasks. At the 7-skill level, supervisory, managerial, training, and quality assurance functions are the dominant characteristics of the job.

ANALYSIS OF AFR 39-1 SPECIALTY DESCRIPTIONS

Survey data were compared to the AFR 39-1 Specialty Descriptions for Antenna/Cable Systems Project/Maintenance Action Specialists and Technicians, both dated 1 February 1988.

The specialty description for the technician (AFSC 36170) accurately reflects both the supervisory and technical nature of the 7-skill level job. The 3-/5-skill level description also appears complete and accurately portrays the range and technical nature of the job.

TRAINING ANALYSIS

Occupational survey data are one of the many sources of information which can be used to assist in the development of a training program relevant to the needs of personnel in their first enlistment. Factors which may be used in evaluating training include the overall description of the job being performed by first-enlistment personnel and their overall distribution across career ladder jobs, percentages of first-job (1-24 months TAFMS) or first-enlistment (1-48 months TAFMS) members performing specific tasks or using certain equipment or tools, as well as training emphasis and task difficulty ratings (previously explained in the SURVEY METHODOLOGY section).

TABLE 8
 REPRESENTATIVE TASKS PERFORMED BY 36170 PERSONNEL

TASKS	PERCENT MEMBERS PERFORMING
B57 RESOLVE TECHNICAL PROBLEMS THAT PERSONNEL ARE UNABLE TO SOLVE	68
C82 INSPECT PERSONNEL FOR COMPLIANCE WITH MILITARY STANDARDS	67
B40 COUNSEL PERSONNEL ON PERSONAL OR MILITARY-RELATED MATTERS	66
D109 MAINTAIN TRAINING RECORDS	66
A6 COORDINATE WORK WITH APPROPRIATE PERSONNEL OR AGENCIES	65
D97 COUNSEL TRAINEES ON TRAINING PROGRESS	63
D94 CONDUCT OJT	63
D91 ANNOTATE TRAINING RECORDS	63
A26 PLAN OR SCHEDULE WORK ASSIGNMENTS	60
C87 WRITE APRs	60
A9 DETERMINE WORK PRIORITIES	58
D107 EVALUATE PROGRESS OF TRAINEES	57
H200 CLIMB POLES OR TOWERS	57
B53 INITIATE ACTION TO CORRECT SUBSTANDARD PERFORMANCE OF PERSONNEL	56
H237 TIE HITCHES IN FIBER ROPES	56
B59 SUPERVISE ANTENNA/CABLE SYSTEMS MAINTENANCE ACTION SPECIALISTS (AFSC 36150)	56
H211 INSPECT SPECIAL PURPOSE VEHICLES OR AUXILIARY EQUIPMENT	55
H241 WORK ALOFT ON METAL STRUCTURES	55
G161 CONDUCT SAFETY BRIEFINGS	54
H238 TIE KNOTS IN FIBER ROPES	54
I263 INSPECT GUYS	51
D98 COUNSEL TRAINERS ON TRAINING RESPONSIBILITIES	50
H220 PERFORM CONSTRUCTION HAND SIGNALS	50
I256 INSPECT ANTENNA OR LINE SUPPORT HARDWARE	50

Average number of tasks performed - 117

TABLE 9

TASKS WHICH BEST DIFFERENTIATE BETWEEN
DAFSC 36130/36150 AND 36170 PERSONNEL
(PERCENT MEMBERS PERFORMING)

TASKS	DAFSC 36130/50 (N=345)	DAFSC 36170 (N=115)	DIFF
H203 DIG TRENCHES BY HAND	79	38	+41
H235 SPLICE FIBER ROPE (NATURAL OR SYNTHETIC)	61	28	+33
H199 CLEAN OR ROD DUCTS	66	34	+32
L390 LOCATE BURIED CABLES	67	36	+31
H242 WORK ALOFT ON WOOD STRUCTURES	72	42	+30
J321 LOAD, UNLOAD, OR TRANSPORT CABLE REELS	68	38	+30
M443 PULL IN UNDERGROUND CABLES USING VEHICLES	61	32	+29
H198 BACKFILL TRENCHES MECHANICALLY	65	37	+28
J348 TROUBLESHOOT CABLE USING MEGGERS	69	41	+28
I292 PUMP OR CLEAN MANHOLES	62	34	+28
L399 PERFORM INITIAL INSTALLATION OF BURIED CABLES USING OPEN TRENCH METHOD	58	30	+28
J333 PREPARE CABLE GRIP ON CABLE ENDS	58	33	+25
O469 PERFORM CORROSION CONTROL ON ANTENNA SYSTEMS	60	36	+24
I272 MEASURE STRAND TENSION USING CAM-LEVER DYNOMETERS	56	32	+24
J349 TROUBLESHOOT CABLE USING MULTIMETERS	67	44	+23

C82 INSPECT PERSONNEL FOR COMPLIANCE WITH MILITARY STANDARDS	21	67	-46
B40 COUNSEL PERSONNEL ON PERSONAL OR MILITARY- RELATED MATTERS	22	66	-44
C87 WRITE APRs	19	60	-41
D107 EVALUATE PROGRESS OF TRAINEES	18	57	-39
A26 PLAN OR SCHEDULE WORK ASSIGNMENTS	22	60	-38
D98 COUNSEL TRAINERS ON TRAINING RESPONSIBILITIES	13	50	-37
B55 INTERPRET POLICIES, DIRECTIVES, OR PROCEDURES FOR SUBORDINATES	15	50	-35
A9 DETERMINE WORK PRIORITIES	24	58	-34
B59 SUPERVISE ANTENNA/CABLE SYSTEMS PROJECT/ MAINTENANCE ACTION SPECIALISTS (AFSC 36150)	23	56	-33
A6 COORDINATE WORK WITH APPROPRIATE PERSONNEL OR AGENCIES	33	65	-32
D94 CONDUCT OJT	32	63	-31
D109 MAINTAIN TRAINING RECORDS	38	66	-28

To assist specifically in evaluation of the Specialty Training Standard (STS) and the Plan of Instruction (POI), technical school personnel from Sheppard Technical Training Center matched job inventory tasks to appropriate sections and subsections of the STS and POI for Course J3ABR36130 000. It was this matching upon which comparison to those documents was based. A complete computer listing displaying the percent members performing tasks, training emphasis and task difficulty ratings for each task, along with the STS and POI matchings, has been forwarded to the technical school for their use in further detailed reviews of appropriate training documents. A summary of this information is presented below.

First-Enlistment Personnel

In this study, there are 220 members in their first enlistment (1-48 months TAFMS), representing over 47 percent of the total survey sample. The job performed by these personnel is highly technical in nature, accounting for approximately 95 percent of their relative duty time (see Table 10). While Table 10 shows that first-term airmen spend some of their job time in a variety of career ladder functional areas, the majority is concentrated on general construction tasks, installing and maintaining antenna and cable support structures, as well as general cable and antenna installation and maintenance tasks. Distribution of these personnel in the career ladder jobs is displayed in Figure 2, which clearly shows group members are more involved in jobs oriented to engineering/electronics installation activities than they are to the one focusing on antenna maintenance. Table 11 displays some of the average 108 tasks performed by the group and is intended to represent a range of tasks across the spectrum from digging ditches to electrical troubleshooting.

One of the objectives of this survey project was to gather data for the technical training center pertaining to various types of construction equipment used or operated, types of tools or equipment used, and types of test equipment used or operated by career ladder personnel. Accordingly, Tables 12 through 14 present percentages of first-term airmen responding to questions concerning their activities involving these items. This type of information is useful for both the technical school and MAJCOM training personnel to assist them in focusing limited training time or other resources on the most utilized items.

Training Emphasis and Task Difficulty Data

Training emphasis (TE) and task difficulty (TD) data are secondary factors that can assist technical school personnel in deciding which tasks should be emphasized in entry-level training. These ratings, based on the judgments of senior career ladder NCOs working at operational units in the field, are collected to provide training personnel with a rank-ordering of those tasks in the job inventory considered important for first-term airman training (TE) (see Table 15 for the top rated tasks), along with a measure of the difficulty of the job inventory tasks (TD) (see the highest rated tasks presented in Table 16). When combined with data on the percentages of first-

TABLE 10

RELATIVE TIME SPENT ON DUTIES BY
FIRST-ENLISTMENT PERSONNEL

DUTIES	PERCENT TIME SPENT
A ORGANIZING AND PLANNING	1
B DIRECTING AND IMPLEMENTING	1
C EVALUATING AND INSPECTING	*
D TRAINING	1
E PERFORMING JOINT TASK FORCE WIRE SECTION TASKS	*
F PERFORMING QUALITY ASSURANCE OR CONTROL TASKS	*
G PERFORMING TEAM CHIEF TASKS	2
H PERFORMING GENERAL CONSTRUCTION TASKS	29
I INSTALLING AND MAINTAINING ANTENNA AND CABLE SUPPORT STRUCTURES	18
J PERFORMING GENERAL CABLE INSTALLATION AND MAINTENANCE TASKS	12
K INSTALLING AND MAINTAINING AERIAL TELEPHONE OR COAXIAL CABLES	3
L INSTALLING AND MAINTAINING BURIED TELEPHONE OR COAXIAL CABLES	6
M INSTALLING AND MAINTAINING UNDERGROUND COAXIAL OR TELEPHONE CABLES	5
N INSTALLING AND MAINTAINING FIBER OPTIC CABLES	1
O PERFORMING GENERAL ANTENNA INSTALLATION AND MAINTENANCE TASKS	7
P INSTALLING AND MAINTAINING WIRE ANTENNAS	2
Q INSTALLING AND MAINTAINING PARABOLIC ANTENNAS	2
R INSTALLING AND MAINTAINING RADOMES	1
S INSTALLING AND MAINTAINING WAVEGUIDES	4
T INSTALLING AND MAINTAINING ROTATABLE LOG PERIODIC (RLP) ANTENNAS	5
U INSTALLING AND MAINTAINING HARDENED ANTENNAS	*

* Less than .5 percent

DISTRIBUTION OF AFSC 361X0 FIRST-ENLISTMENT PERSONNEL ACROSS SPECIALTY JOBS (N= 220)

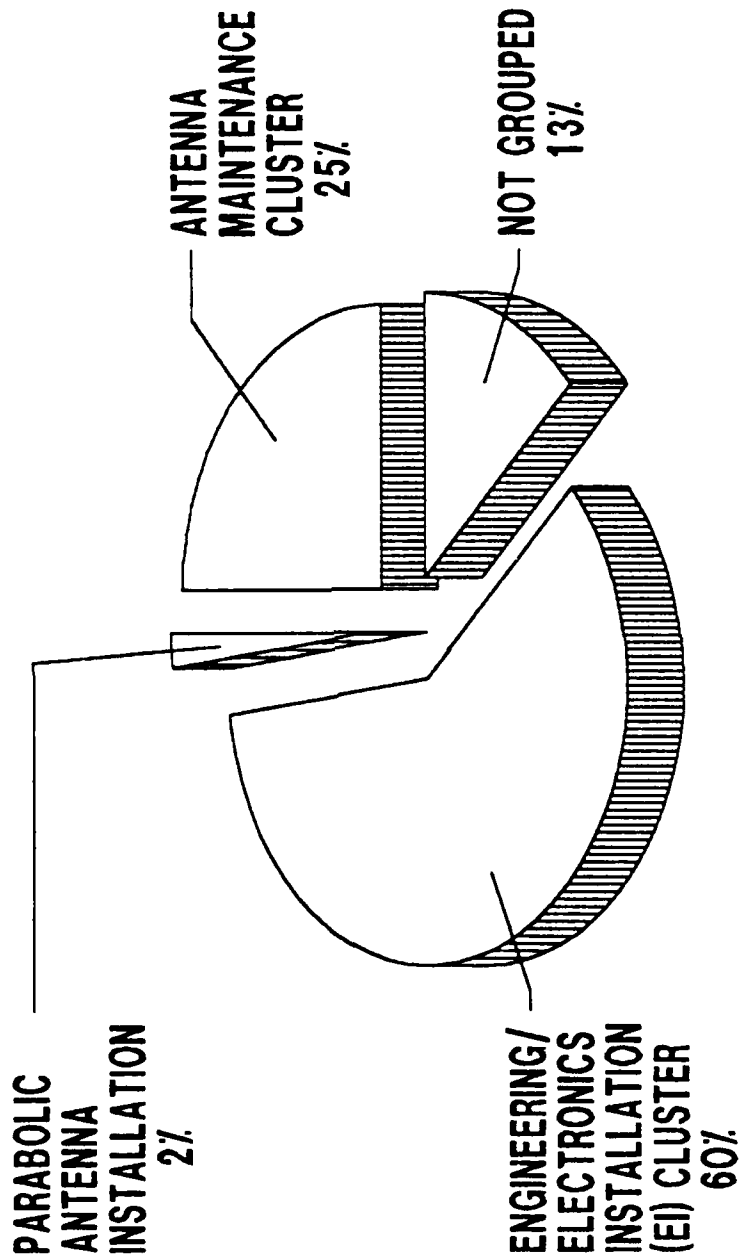

FIGURE 2

TABLE 11
 REPRESENTATIVE TASKS PERFORMED
 BY 361X0 FIRST-ENLISTMENT PERSONNEL
 (N=220)

TASKS	PERCENT MEMBERS PERFORMING
H200 CLIMB POLES OR TOWERS	93
H238 TIE KNOTS IN FIBER ROPES	90
H237 TIE HITCHES IN FIBER ROPES	88
H241 WORK ALOFT ON METAL STRUCTURES	87
H197 BACKFILL TRENCHES MANUALLY	86
H220 PERFORM CONSTRUCTION HAND SIGNALS	84
H207 FABRICATE ROLLED EYE SPLICES	73
J321 LOAD, UNLOAD, OR TRANSPORT CABLE REELS	73
H199 CLEAN OR ROD DUCTS	73
H242 WORK ALOFT ON WOOD STRUCTURES	72
I263 INSPECT GUYS	70
L390 LOCATE BURIED CABLES	70
H204 DIG TRENCHES USING POWER EQUIPMENT, SUCH AS BACKHOES OR TRENCHES	67
H198 BACKFILL TRENCHES MECHANICALLY	67
J345 SECURE CABLES WITH WRAPLOCK	67
J348 TROUBLESHOOT CABLE USING MEGGERS	67
I314 TEST MANHOLE FOR COMBUSTIBLE AND TOXIC GASES AND OXYGEN DEFICIENCY	66
J349 TROUBLESHOOT CABLE USING MULTIMETERS	66
M443 PULL IN UNDERGROUND CABLES USING VEHICLES	65
H202 DIG POLE HOLES USING POWER EQUIPMENT	65
L399 PERFORM INITIAL INSTALLATION OF BURIED CABLE USING OPEN TRENCH METHOD	64
J325 PERFORM INITIAL INSTALLATION OF FLEXIBLE COAXIAL CABLE CONNECTORS	60
I256 INSPECT ANTENNA OR LINE SUPPORT HARDWARE	60
L397 PERFORM INITIAL INSTALLATION OF BURIED CABLE MARKERS	60
H221 PERFORM CRANE OPERATING HAND SIGNALS	59
I272 MEASURE STAND TENSION USING CAM-LEVER DYNOMETERS	58
O463 IDENTIFY OR TAG ANTENNAS	58
O479 PLUMB ANTENNA SYSTEMS USING TRANSIT METHOD	55
H232 REMOVE OR REPLACE LIGHTNING PROTECTION DEVICES FROM POLES AND TOWERS	51
L408 PERFORM INITIAL INSTALLATION OF BURIED TELEPHONE CABLES	50
J347 TEST CABLE PRESSURE	50

Average number of tasks performed - 108

TABLE 12

CONSTRUCTION EQUIPMENT OPERATED BY 20 PERCENT
OR MORE OF FIRST-ENLISTMENT PERSONNEL
(N=220)

<u>EQUIPMENT OPERATED</u>	<u>PERCENT MEMBERS RESPONDING</u>
TRUCK, SIX PACK 4x4	85
TRUCK, SIX PACK 4x2 ½-TON	75
VEHICLE, LOW PROFILE	67
TRAILER, HYDRAULIC CABLE REEL	64
DITCH WITCH	61
BACKHOE	59
TRUCK, V-11 LINE	59
TRUCK, COMMERCIAL DIESEL 2½-TON	47
TRAILER, COMBINATION POLE AND CABLE	47
FORKLIFT (UP TO 20,000 LBS)	42
TRAILER, NONHYDRAULIC CABLE	41
TRENCHER, 70 + 4	38
TRUCK, DIESEL M-35 2½-TON	37
TRUCK, GASOLINE 2½-TON	37
TRUCK, CARGO 4x4 3½-TON	35
TRUCK, TRACTOR TRAILER (5 TO 10 TON)	34
CARRY-ALL	33
FRONT-END LOADER	32
FRONT-END LOADER, WITH BACKHOE	31
VEHICLE, MID-PROFILE	31
POLE TRAILER	30
TRAILER, 25-FOOT	29
VEHICLE, HIGH-PROFILE	29
TRAILER, UTILITY GPC-28	25
TRAILER, TILT	23

TABLE 13

TOOLS OR EQUIPMENT USED OR OPERATED BY
50 PERCENT OR MORE OF FIRST-ENLISTMENT PERSONNEL
(N=220)

<u>TOOLS OR EQUIPMENT</u>	<u>PERCENT MEMBERS RESPONDING</u>
CLIMBING EQUIPMENT	94
CHAIN HOISTS	94
SHOVELS	92
LINEMAN WRENCHES	92
SLEDGE HAMMERS	91
SNATCH BLOCKS	90
DIGGING BARS	88
HANDLINES AND BUCKETS	88
ELECTRIC DRILLS	87
COFFIN HOISTS	87
WALKING OR MEASUREMENT WHEELS (CYCLOMETERS)	87
CABLE JACKS	84
BOLT CUTTERS	84
CABLE CUTTERS	82
GAFF GAUGES	82
CABLE GRIPS	81
WIRE HOISTS	80
MANHOLE COVER HOOKS	79
TRANSITS	78
SHEAVES AND SHACKLES	77
PICKS	76
SOLDERING GUNS	75
STRAND GRIPS	75
SWIVEL SHACKLES	74
MANHOLE RAIL GUARDS	71
WIRE LASHING CLAMPS	71
PIPE WRENCHES	70
DUCT RODS	70
BLOCK AND TACKLE	69
CRIMPING TOOLS	69
TORQUE WRENCHES	69
WATER PUMPS	68
PORTABLE GAS GENERATORS	66
SAFETY KITS	66
CABLE LASHERS	66
STENCIL KITS	65
TAMPERS	65
TUBE CUTTERS	63
TRAFFIC WARNING DEVICES	62
CABLE BENDING SHOES	60
HILTI TOOLS	58
CANT HOOKS	57
PULLING FRAMES	56
AERIAL CABLE GUIDES	55
CABLE PULLING GUIDES	51

TABLE 14
 TEST EQUIPMENT USED OR OPERATED BY
 20 PERCENT OR MORE FIRST-ENLISTMENT PERSONNEL
 (N=220)

<u>TEST EQUIPMENT</u>	<u>PERCENT MEMBERS RESPONDING</u>
MULTIMETERS	91
MEGGERS	88
OHMMETERS	78
BURIED CABLE AND FAULT LOCATORS	63
TIME DOMAIN REFLECTOMETERS (TDR)	63
CAM-LEVER STRAND DYNOMETERS	56
VOLTMETERS	50
SPECTRUM ANALYZERS	49
DETECTORS (TRITECTOR)	47
TOXIC AND COMBUSTIBLE GAS INDICATORS (CGS-10M)	47
OPTICAL TIME DOMAIN REFLECTOMETERS (1502/3)	37
THRU LINE WATTMETERS	36
TRACTION-TYPE STRAND DYNOMETERS	27
IMPEDANCE BRIDGES	26
DELCON CABLE LOCATORS	25
PORTABLE PRESSURE TESTING KITS	23
SIGNAL GENERATORS	22
RF BRIDGES	22
DEFLECTION-TYPE STRAND DYNOMETERS	21
TELEPHONE TEST SETS	20
RESISTANCE BRIDGES	20

TABLE 15

TECHNICAL TASKS RATED HIGHEST IN TRAINING EMPHASIS (TE)

TASKS	TNG EMP*	PERCENT MEMBERS PERFORMING		TASK DIFF**
		1ST JOB (N=76)	1ST ENL (N=220)	
I314 TEST MANHOLE FOR COMBUSTIBLE AND TOXIC GASES AND OXYGEN DEFICIENCY	6.82	58	66	4.53
H200 CLIMB POLES OR TOWERS	6.62	93	93	4.12
J351 TROUBLESHOOT CABLE USING TIME DOMAIN REFLECTOMETERS	6.49	33	42	6.52
H241 WORK ALOFT ON METAL STRUCTURES	6.40	82	87	4.38
H215 INTERPRET SCHEMATIC DIAGRAMS	6.38	26	37	6.59
J348 TROUBLESHOOT CABLE USING MEGGERS	6.33	55	67	4.30
J349 TROUBLESHOOT CABLE USING MULTIMETERS	6.22	58	66	4.43
H237 TIE HITCHES IN FIBER ROPES	6.20	86	88	3.36
H242 WORK ALOFT ON WOOD STRUCTURES	6.18	64	72	4.93
T583 TROUBLESHOOT RLP ANTENNA ELECTRICAL COMPONENTS, SUCH AS RELAYS, CAPACITORS, OR DIODES	6.13	17	18	7.14
H238 TIE KNOTS IN FIBER ROPES	6.11	84	90	3.19
H204 DIG TRENCHES USING POWER EQUIPMENT, SUCH AS BACKHOES OR TRENCHERS	6.09	57	67	4.18
T561 INTERPRET RLP ANTENNA ELECTRICAL SCHEMATICS	6.02	25	30	6.98
T579 TROUBLESHOOT RLP ANTENNA ELECTRICAL COMPONENTS USING MULTIMETERS	5.98	20	26	5.83

* Mean TE rating is 2.93, and Standard Deviation is 1.63 (High TE=4.56)

** Average TD rating is 5.00

TABLE 16

TASKS RATED HIGHEST IN TASK DIFFICULTY (TD)

TASKS	TASK DIFF*	PERCENT MEMBERS PERFORMING			
		1ST ENL (N=220)	DAFSC 36150 (N=297)	DAFSC 36170 (N=115)	
A19 DRAFT BUDGET REQUIREMENTS	8.44	1	4	23	
C89 WRITE STAFF STUDIES, SURVEYS, OR SPECIAL REPORTS, OTHER OTHER THAN TRAINING REPORTS	7.96	1	4	23	
A10 DEVELOP COST-REDUCTION PROGRAMS	7.67	1	3	16	
C65 EVALUATE BUDGET REQUIREMENTS	7.29	1	3	19	
U618 REMOVE OR REPLACE EXPLOSIVE DEVICES	7.26	0	1	0	
C88 WRITE RECOMMENDATIONS FOR AWARDS AND DECORATIONS	7.23	1	12	43	
A20 ESTABLISH ORGANIZATIONAL POLICIES	7.17	1	4	14	
T583 TROUBLESHOOT RLP ANTENNA ELECTRICAL COMPONENTS, SUCH AS RELAYS, CAPACITORS, OR DIODES	7.14	18	21	21	
U614 PERFORM INITIAL INSTALLATION OF EXPLOSIVE DEVICES	7.10	0	1	0	
T561 INTERPRET RLP ANTENNA ELECTRICAL SCHEMATICS	6.98	30	37	32	
D100 DEVELOP CAREER DEVELOPMENT COURSE (CDC) MATERIALS	6.93	1	3	5	
A13 DEVELOP MANPOWER REQUIREMENTS	6.92	4	6	15	
D101 DEVELOP NEW EQUIPMENT TRAINING PROGRAMS	6.92	1	5	14	
T569 REBUILD RLP ANTENNA ELECTRICAL COMPONENTS	6.90	14	15	13	
S554 TROUBLESHOOT WAVEGUIDES USING SPECTRUM ANALYZERS	6.89	6	6	6	
N462 TEST FIBER OPTIC CABLE USING TIME DOMAIN REFLECTOMETERS	6.86	4	3	5	
S558 TUNE WAVEGUIDE CONNECTORS	6.84	4	7	6	

* Average TD rating is 5.00

enlistment personnel performing tasks, comparisons can then be made to determine if training adjustments are necessary. For example, tasks receiving high ratings on both task factors, accompanied by moderate to high percentages performing, may warrant resident training. Those tasks receiving high task factor ratings, but low percentages performing, may be more appropriately planned for OJT programs within the career ladder. Low task factor ratings may highlight tasks best omitted from training for first-term personnel, but this decision must be weighed against percentages of personnel performing the tasks, command concerns, and criticality of the tasks.

To assist technical school personnel, USAFOMC has developed a computer program that incorporates these secondary factors and the percentage of first-enlistment personnel performing each task into a computed value identified as an Automated Training Indicator (ATI). These ATI values correspond to training decisions listed and defined in the Training Decision Logic Table found in Attachment 1, ATR 52-22. These values allow course personnel to quickly focus their attention on those tasks which are most likely to qualify for ABR course consideration.

Various lists of tasks, accompanied by TE and TD ratings, and where appropriate, ATI values, are contained in the TRAINING EXTRACT package and should be reviewed in detail by technical school personnel. (For a more detailed explanation of TE and TD ratings, see Task Factor Administration in the SURVEY METHODOLOGY section of this report.)

Specialty Training Standard (STS)

A comprehensive review of STS 361X0, dated October 1987, compared STS items to survey data (based on the previously mentioned assistance from technical school personnel in matching job inventory tasks to STS elements). STS paragraphs containing general knowledge information, subject-matter-only knowledge requirements, or basic supervisory responsibilities were not examined. Task knowledge and performance elements of the STS were compared against the standard set forth in AFR 8-13 (dated 1 August 1986) and AFR 8-13/ATC Supplement 1 (dated 2 March 1987), Attachment 1, paragraph A1-3c(4) (i.e., include tasks performed or knowledge required by 20 percent or more of the personnel in a skill level (criterion group) of the AFS).

Overall, the STS provides comprehensive coverage of the work performed by personnel in the field, with survey data supporting most of the essential paragraphs or subparagraphs. While some tasks did not have high percentages of personnel performing them, above average TE or TD ratings, or the fact that the tasks were a part of an identifiable job being performed in the career ladder, support the retention of the STS elements involving these tasks.

Even using the above criterion, several elements of the STS were still not supported by occupational survey data, and require further review by training personnel and subject-matter experts. Table 17 provides a listing of STS elements requiring review, and displays these elements under two columns identifying the nature of the problem (some elements may fall into both

TABLE 17

LISTING OF STS ELEMENTS REQUIRING REVIEW

<u>QUESTIONABLE PROFICIENCY CODES</u>	<u>LESS THAN 20 PERCENT GROUP MEMBERS PERFORMING</u>
13. ANTENNA SYSTEM SUPPORT 13f(1) 13h(1) 13h(2) 13j(1) 13j(2)	9. PRE-MDM SPECIAL ACTIONS 9b
14. ANTENNA SYSTEMS 14i 14s	13. ANTENNA SYSTEM SUPPORT 13p 13q 13r
18. POLE LINE CONSTRUCTION 18j(1) 18j(5)	14. ANTENNA SYSTEMS 14o(2) 14q(2) 14p(1) 14r
21. UNDERGROUND CABLE SYSTEMS 21f(2)(a)	18. POLE LINE CONSTRUCTION 18j(2) 18j(3) 18j(4)
	20. AERIAL CABLE SYSTEMS 20e(2) 20f(2)
	21. UNDERGROUND CABLE SYSTEMS 21i(2) 21m
	23. FIBER OPTICS 23c(2) 23c(3)

categories). Table 18 displays selected examples of those elements. Most reflect low percentages of personnel across all pertinent group populations performing tasks keyed to those elements. Even though the tasks shown are slightly above average in difficulty, and one reflects a high TE rating, the low performance figures for these examples and the other elements listed in Table 17 suggest evaluation to justify retention in the STS is warranted.

Tasks not matched to any element of the STS are listed at the end of the STS computer listing. These were reviewed to determine if there were any tasks concentrated around any particular functions or jobs. No particular trends were noted. Examples of technical-type tasks performed by 20 percent or more respondents of the STS target groups, but which were not referenced to any STS element, are displayed in Table 19. Training personnel and subject-matter experts should review these and other eligible unreferenced tasks to determine if inclusion in the STS is justified.

Plan of Instruction (POI)

Based on the previously mentioned assistance from the technical school subject-matter experts in matching inventory tasks to the 3ABR36130 000 POI, dated 1 May 1989, a computer product was generated displaying the results of the matching process. Information furnished for consideration includes percent members performing data for first-job (1-24 months TAFMS) and first-enlistment (1-48 months TAFMS) personnel, as well as training emphasis (TE) and task difficulty (TD) ratings for individual tasks.

POI blocks, units of instruction, and criterion objectives were compared against the standard set forth in Attachment 1, ATCR 52-22, dated 17 February 1989 (30 percent or more of the criterion first-enlistment group performing tasks trained, along with sufficiently high TE and TD ratings on those tasks). Per this guidance, tasks trained in the course which do not meet these criteria must be considered for elimination from the formal course, if not justified on some other acceptable basis.

Review of the tasks matched to the POI reveals that most POI blocks and units of instruction are well supported by survey data, based on percentages of first-term personnel performing tasks or high TE or TD ratings for pertinent tasks. There are three units of instruction, however, which contain some objectives that apparently are not supported by survey data and require further evaluation by training personnel and subject-matter experts (see display in Table 20). While many of these selected sample tasks have above average TD ratings, all reflect less than 30 percent of the first-term population performing, and only one received a high TE rating (4.56 or above). The combination of low percent members performing and TE factors suggests the need for a close look at the pertinent objectives in these units of instruction to determine if retention of these 16 hours in the ABR course is justified.

TABLE 18

SAMPLES OF STS ELEMENTS REQUIRING REVIEW

STS ITEM (WITH SELECTED SAMPLE TASKS)	PERCENT MEMBERS PERFORMING						TNG EMP*	TASK DIFF**
	3 LVL PROF CODE	1ST JOB (N=76)	1ST ENL (N=220)	DAFSC 36150 (N=297)	DAFSC 36170 (N=115)			
13h(1) INSTALL GUYED ANTENNA SUPPORTS USING FIXED GIN POLE	2b	5	6	8	5	3.62	5.23	
I247 Erect poles using stationary gin pole method								
14i INSTALL GROUND REFLECTOR SYSTEMS	b	9	11	11	7	4.04	5.61	
P493 Perform initial installation of ground reflector systems								
13q MAINTAIN RADOMES	-	14	10	8	4	3.13	5.10	
R518 Maintain radomes								
20e(2) INSTALL AERIAL FIBER OPTIC CABLE	-	4	4	4	3	4.62	5.50	
N454 Perform initial installation of aerial fiber optic cable								

* Mean TE Rating is 2.93, and Standard Deviation is 1.63 (High TE = 4.56)

** Average TD Rating is 5.00

TABLE 19

EXAMPLES OF TECHNICAL-TYPE TASKS PERFORMED BY 20 PERCENT OR MORE OF GROUP MEMBERS AND NOT REFERENCED TO THE STS

TASKS	PERCENT MEMBERS PERFORMING						TE RATING*	TD RATING**
	1ST JOB (N=76)	1ST ENL (N=220)	DAFSC 36150 (N=297)	DAFSC 36170 (N=115)				
J332 PERFORM PLASTIC SHEATH REPAIRS ON TELEPHONE CABLES	17	32	35	18		4.51	4.06	
H206 ESTABLISH DATUM LINES	21	25	22	18		3.91	5.51	
I306 REMOVE OR REPLACE UNDERGROUND CABLE RACKS	17	22	24	13		2.98	3.85	
B37 ADJUST DAILY MAINTENANCE PLANS TO MEET OPERATIONAL COMMITMENTS	4	3	6	22		.31	5.41	
B58 REVIEW TEST EQUIPMENT CALIBRATION SCHEDULES	4	9	16	32		1.29	3.50	
C68 EVALUATE MAINTENANCE AND INSPECTION REPORT FINDINGS	7	4	6	29		1.11	5.57	
I279 PERFORM INITIAL INSTALLATION OF CONDUITS	12	21	20	10		2.56	4.73	

* Mean TE Rating is 2.93, and Standard Deviation is 1.63 (High TE = 4.56)

** Average TD Rating is 5.00

TABLE 20

POI BLOCKS REFLECTING LOW FIRST-ENLISTMENT TASK PERFORMANCE
(LESS THAN 30 PERCENT RESPONDING)

POI REFERENCE BLOCK - UNIT	TIME (HOURS)	SELECTED SAMPLE TASKS	PERCENT MEMBERS PERFORMING			TNG EMP*	TASK DIFF**
			1ST JOB (N=76)	1ST ENL (N=220)			
IV 6c	2:00	P493 PERFORM INITIAL INSTALLATION OF GROUND REFLECTOR SYSTEMS	9	11	4.04	5.61	
V 2a	5:00	S542 PERFORM INITIAL INSTALLATION OF RIGID WAVEGUIDES S547 REMOVE OR REPLACE RIGID WAVEGUIDES	12 16	15 17	4.56 4.00	5.50 5.22	
V 2e	3:00	J322 MAINTAIN DEHYDRATORS J352 TROUBLESHOOT DEHYDRATORS	22 13	23 15	3.80 3.49	4.80 5.82	
VII 1a-b	6:00	G145 ANNOTATE AS-BUILT DRAWINGS F141 UPDATE CEFRs	7 3	15 4	3.47 2.42	4.73 5.14	

* Mean TE Rating is 2.93, and Standard Deviation is 1.63 (High TE = 4.56)

** Average TD Rating is 5.00

Additionally, some apparently significant tasks with above average or high TE ratings, sufficiently high TD ratings, and 30 percent or more first-job or first-enlistment personnel were not matched to any POI blocks of instruction. This combination of factors indicates formal training may be justified, and resident technical training could be supported. Table 21 lists a sampling of a number of such tasks. Subject-matter experts and training personnel should perform an in-depth review of these and other qualifying tasks contained in the "Tasks Not Referenced" section of the previously mentioned computer printout to determine the necessity for training and the most effective method to accomplish it.

Overall, the current training appears to be effective, with first-term personnel rendering very high positive ratings on utilization of training (see Table 24, JOB SATISFACTION ANALYSIS section).

Electronics Principles (EP)

The ELECTRICAL FUNDAMENTALS paragraph of the STS and the electrical fundamentals taught in the ABR course can be evaluated using data collected by the Electronics Principles Inventory (EPI). The EPI is a knowledge-based inventory containing 712 electronics principles, skills, and equipment questions covering 39 electronics principles subject areas. The inventory was administered to a randomly selected sample of 5-skill level personnel in various AFSCs, including 361X0 airmen. The inventory is designed to identify the range of electrical/electronics principles affected personnel must understand to perform any electrical/electronics-related job.

Table 22 lists the subject areas where 30 percent or more of AFSC 36150 airmen responded "yes" to performing functions in their jobs requiring electrical/electronics skills or knowledge. These data, as well as the complete data package for Sheppard Technical Training Center AFSCs (EPI Report, AFPT 90-EPI-825, dated July 1988), can be useful to subject-matter experts when evaluating those portions of the STS and POI concerning electrical/electronics fundamentals or principles.

ANALYSIS OF MAJOR COMMANDS (MAJCOM)

Although AFCC personnel constitute 91 percent of the 361X0 career ladder population, jobs performed by Electronic Security Command (ESC) airmen and personnel assigned to Air Force Elements (Europe) supporting various special operations (i.e., NATO) were compared to determine if job content varied by MAJCOM assignment.

As would be expected, AFCC personnel are involved in the full range of the specialty jobs, spending time on tasks pertaining to both initial installation and maintenance of various cable and antenna systems. ESC personnel and airmen assigned to Air Force Elements (Europe) reported very limited

TABLE 21

SAMPLING OF TASKS NOT REFERENCED TO 3ABR36130 000 POI BLOCKS
(30 PERCENT OR MORE RESPONDING)

EXAMPLES OF TASKS NOT REFERENCED	PERCENT MEMBERS PERFORMING		TNG EMP*	TASK DIFF**
	1ST JOB (N=76)	1ST ENL (N=220)		
H212 INSPECT TRENCHERS	41	57	5.33	4.06
J332 PERFORM PLASTIC SHEATH REPAIRS ON TELEPHONE CABLES	17	32	4.51	4.06
L402 PERFORM INITIAL INSTALLATION OF BURIED FLEXIBLE COAXIAL CABLES	26	30	4.00	4.48
L419 REMOVE OR REPLACE BURIED TELEPHONE CABLES	36	41	3.49	4.48
I249 ERECT TOWERS USING CRANE METHOD	18	30	5.47	4.98
J340 REMOVE OR REPLACE RIGID COAXIAL CABLE CONNECTORS	32	33	4.73	4.46

* Mean TE Rating is 2.93, and Standard Deviation is 1.63 (High TE = 4.56)

** Average TD Rating is 5.00

TABLE 22

ELECTRONICS PRINCIPLES USED BY 30 PERCENT
OR MORE DAFSC 36150 PERSONNEL

BASIC TERMS

BASIC CIRCUITS

ALTERNATING CURRENT (AC)

DIRECT CURRENT (DC)

RESISTORS

RELAYS/SOLENOIDS

SOLDER/DESOLDER

TERMINAL CONNECTIONS

MULTIPIN CONNECTORS

COAXIAL CONNECTORS

ASSEMBLE SOLDERLESS CONNECTORS

CRIMP

COAXIAL

MULTIPIN

TEST EQUIPMENT

ANALOG MULTIMETER

SPECTRUM ANALYZER

DIGITAL MULTIMETER

TRANSMISSION LINES

WAVEGUIDES

TRANSMISSION POWER

ANTENNAS

TABLE 23

PERCENTAGE OF TIME SPENT ON DUTIES BY MAJCOM GROUPS

<u>DUTIES</u>	<u>AFCC (N=416)</u>	<u>ESC (N=13)</u>	<u>AF ELEMENTS (EUROPE) (N=16)</u>
A ORGANIZING AND PLANNING	6	4	8
B DIRECTING AND IMPLEMENTING	4	4	6
C EVALUATING AND INSPECTING	4	1	6
D TRAINING	5	3	5
E PERFORMING JOINT TASK FORCE WIRE SECTION TASKS	*	*	0
F PERFORMING QUALITY ASSURANCE OR CONTROL TASKS	1	*	1
G PERFORMING TEAM CHIEF TASKS	6	6	4
H PERFORMING GENERAL CONSTRUCTION TASKS	22	19	15
I INSTALLING AND MAINTAINING ANTENNA AND CABLE SUPPORT STRUCTURES	14	14	10
J PERFORMING GENERAL CABLE INSTALLATION AND MAINTENANCE TASKS	10	15	8
K INSTALLING AND MAINTAINING AERIAL TELEPHONE OR COAXIAL CABLES	2	1	*
L INSTALLING AND MAINTAINING BURIED TELEPHONE OR COAXIAL CABLES	5	3	3
M INSTALLING AND MAINTAINING UNDERGROUND COAXIAL OR TELEPHONE CABLES	4	1	1
N INSTALLING AND MAINTAINING FIBER OPTIC CABLES	*	*	0
O PERFORMING GENERAL ANTENNA INSTALLATION AND MAINTENANCE TASKS	6	12	8
P INSTALLING AND MAINTAINING WIRE ANTENNAS	2	3	4
Q INSTALLING AND MAINTAINING PARABOLIC ANTENNAS	1	2	4
R INSTALLING AND MAINTAINING RADOMES	*	1	0
S INSTALLING AND MAINTAINING WAVEGUIDES	3	1	14
T INSTALLING AND MAINTAINING ROTATABLE LOG PERIODIC (RLP) ANTENNAS	5	9	3
U INSTALLING AND MAINTAINING HARDENED ANTENNAS	*	1	0

* Less than 1 percent

involvement with initial installation tasks in general, and reflected very little time spent on tasks peculiar to aerial and underground cable systems (see Table 23).

The most notable variations for ESC airmen pertain to higher percentages of relative duty time spent on tasks involving general antenna maintenance and maintenance peculiar to rotatable log periodic antennas. Personnel supporting special activities in Europe reported less involvement with general cable maintenance tasks, while spending somewhat larger percentages of their relative duty time on tasks pertaining to maintenance of parabolic antennas and waveguides (see Table 23).

While some variations can be seen in the relative time spent on some cable and antenna systems by the small populations in the other two operational commands, the number of personnel involved is too small to suggest any variation in the initial formal training program for career ladder personnel. If desired, career ladder managers could meet any necessary specialized training needs by working with ATC training specialists to develop programs concentrating on systems with which the target populations are most involved.

ANALYSIS OF CONUS VERSUS OVERSEAS GROUPS

Comparisons were also made of the tasks performed and background data for the 175 DAFSC 36150 personnel assigned to Continental United States (CONUS) bases versus the 108 DAFSC 36150 airmen in the sample assigned to overseas locations. The scope of the job performed by CONUS personnel is slightly larger (an average of 135 tasks performed versus 119 for overseas airmen). Although some minor variations can be seen in the higher percentage of relative duty time overseas personnel spend on tasks pertaining to maintaining parabolic antennas and waveguides, by and large, review of the various tasks and duties performed by the two groups indicates no substantial differences in the overall jobs performed. Comparison of general background data reveals little difference in characteristics for the two groups.

JOB SATISFACTION ANALYSIS

An examination of the job satisfaction indicators of various groups can give career ladder managers a better understanding of some of the factors which may affect the job performance of airmen in the career ladder. Attitude questions covering job interest, perceived utilization of talents and training, sense of accomplishment from work, and reenlistment intentions were included in the survey booklet to provide indications of job satisfaction. Table 24 presents job satisfaction data for AFSC 361X0 TAFMS groups, together with data for a comparative sample of Mission Equipment Maintenance career ladders surveyed in 1989. These data can give a relative measure of how the job satisfaction of AFSC 361X0 personnel compares with other similar Air Force

TABLE 24

COMPARISON OF JOB SATISFACTION INDICATORS BY TAFMS GROUPS
(PERCENT MEMBERS RESPONDING)*

	1-48 MOS TAFMS		49-96 MOS TAFMS		97+ MOS TAFMS	
	361X0 (N=220)	COMP SAMPLE** (N=2,658)	361X0 (N=85)	COMP SAMPLE** (N=1,930)	361X0 (N=155)	COMP SAMPLE** (N=2,575)
<u>EXPRESSED JOB INTEREST:</u>						
INTERESTING	80	76	81	75	82	77
SO-SO	15	15	6	16	8	14
DULL	4	8	13	8	8	8
<u>PERCEIVED UTILIZATION OF TALENTS:</u>						
FAIRLY WELL TO PERFECTLY	90	85	83	85	85	84
LITTLE OR NOT AT ALL	10	15	16	14	14	15
<u>PERCEIVED UTILIZATION OF TRAINING:</u>						
FAIRLY WELL TO PERFECTLY	93	88	85	83	84	82
LITTLE OR NOT AT ALL	6	12	14	16	15	18
<u>REENLISTMENT INTENTIONS:</u>						
YES, OR PROBABLY YES	56	61	66	72	72	75
NO, OR PROBABLY NO	42	37	32	26	6	10
PLAN TO RETIRE	2	2	1	1	19	14

* Columns may not add to 100 percent due to nonresponse or rounding
 ** Comparative sample of Mission Equipment Maintenance career ladder surveyed in 1989 (Includes AFSCs 362X4, 411X2A, 451X4, and 454X0A/B)

specialties. An indication of how job satisfaction perceptions have changed over time is provided in Table 25, where TAFMS group data for 1990 survey respondents are presented, along with data from respondents to the last occupational survey involving this career ladder, published in 1986. Finally, Table 26 presents job satisfaction responses for the specialty job groups discussed in the SPECIALTY JOBS section of this report. An examination of these data can show how overall job satisfaction may be influenced by the type of job performed.

Review of Table 24 reflects that responses from 361X0 TAFMS groups regarding job interest, use of talents, and use of training are all very positive (80 percent or more), and are generally slightly higher than most of the comparative groups. Reenlistment intentions for 361X0 groups, while still positive, are lower than the comparative sample for the 49-96 and 97+ month TAFMS groups.

Comparison of job satisfaction indicator responses of current survey TAFMS groups to those in the 1986 survey (see Table 25) indicates that positive responses are almost all equal to or higher than those for 1986 corresponding groups. The most notable exception is the somewhat lower response concerning reenlistment intentions by the current survey 49-96 month group.

Review of the job satisfaction data for the jobs identified in the SPECIALTY JOBS analysis (see Table 26) reveals that personnel in all but one job (TRAINING - representing only one percent of the sample) responded very positively to all of the indicators listed. Additionally, review of the job inventory write-in comments from survey sample personnel further supports the high job satisfaction indications for the overall career ladder.

When there are serious problems in a career ladder, survey respondents are usually quite free with write-in comments to complain about perceived problems in the field. Fourteen percent of the survey sample used the write-in feature to convey some type of information, yet only 7 percent of the comments received (representing only one percent of the total sample) could be characterized as complaints. No particular trends were noted among the few comments received.

The high percentages of positive responses in these comparisons reflect a career ladder where personnel appear to be well satisfied with their jobs.

IMPLICATIONS

This survey was requested by training personnel to obtain current task and equipment data for their use in reviewing current training programs. Review of the Specialty Training Standard (STS) indicated a number of elements that require evaluation for retention due to low percentages of target populations performing the tasks matched, or because of questionable proficiency codings.

TABLE 25

COMPARISON OF CURRENT SURVEY AND 1986 361X0 TAFMS GROUPS
(PERCENT MEMBERS RESPONDING POSITIVELY)

	<u>1-48 MONTHS TAFMS</u>		<u>49-96 MONTHS TAFMS</u>		<u>97+ MONTHS TAFMS</u>	
	1990 (N=220)	1986 (N=273)	1990 (N=85)	1986 (N=114)	1990 (N=155)	1986 (N=223)
<u>JOB SATISFACTION INFORMATION:</u>						
JOB FAIRLY INTERESTING OR BETTER	80	82	81	82	82	76
TALENTS UTILIZED FAIRLY WELL OR BETTER	90	84	83	83	85	84
TRAINING UTILIZED FAIRLY WELL OR BETTER	93	89	85	87	84	84
FAVORABLY CONSIDERING REENLISTMENT	56	49	66	83	72	74

TABLE 26

COMPARISONS OF JOB SATISFACTION INDICATORS BY SPECIALTY JOB CLUSTERS AND INDEPENDENT JOBS
(PERCENT MEMBERS RESPONDING)*

	ENGINEERING/ ELECTRONICS INSTALLATION (EI) (N=230)	ANTENNA MAINTENANCE (N=122)	PARABOLIC ANTENNA INSTALLATION (N=6)	SUPERVISION (N=31)	QUALITY ASSURANCE (N=5)	TRAINING (N=7)
<u>EXPRESSED JOB INTEREST:</u>						
INTERESTING	83	78	100	90	100	14
SO-SO	8	12	0	3	0	29
DULL	6	9	0	6	0	57
<u>PERCEIVED USE OF TALENTS:</u>						
FAIRLY WELL TO PERFECTLY LITTLE OR NOT AT ALL	91 9	87 12	83 17	84 16	100 0	28 71
<u>PERCEIVED USE OF TRAINING:</u>						
FAIRLY WELL TO PERFECTLY LITTLE OR NOT AT ALL	93 7	91 9	100 0	87 13	100 0	29 71
<u>SENSE OF ACCOMPLISHMENT FROM JOB:</u>						
SATISFIED	86	79	100	90	100	14
NEUTRAL	8	8	0	3	0	0
DISSATISFIED	6	11	0	6	0	86
<u>REENLISTMENT INTENTIONS:</u>						
YES, OR PROBABLY YES	64	62	83	52	60	86
NO, OR PROBABLY NO	30	33	17	19	0	0
PLAN TO RETIRE	4	2	0	29	40	14

* Columns may not add to 100 percent due to nonresponse or rounding

The review of the Plan of Instruction (POI) of the ABR course for this career ladder revealed three units of instruction contain objectives (five, representing 16 hours of instruction) that are not supported by survey data. Additionally, a series of tasks performed by sufficient numbers of first-term personnel and reflecting sufficiently high TE ratings should also be considered for possible inclusion in the ABR course.

APPENDIX A
SELECTED REPRESENTATIVE TASKS PERFORMED
BY CAREER LADDER STRUCTURE GROUPS

TABLE I

GROUP ID NUMBER AND TITLE: ST0041, ENGINEERING/ELECTRONICS INSTALLATION (EI) CLUSTER

GROUP SIZE: 230

PERCENT OF SAMPLE: 50%

PREDOMINANT GRADE: E-3/E-4

AVERAGE TICF: 58 MONTHS

AVERAGE TAFMS: 64 MONTHS

THE FOLLOWING ARE IN DESCENDING ORDER BY PERCENT MEMBERS PERFORMING:

REPRESENTATIVE TASKS	PERCENT MEMBERS PERFORMING
H200 CLIMB POLES OR TOWERS	97
H199 CLEAN OR ROD DUCTS	97
H220 PERFORM CONSTRUCTION HAND SIGNALS	94
M443 PULL IN UNDERGROUND CABLES USING VEHICLES	92
I314 TEST MANHOLE FOR COMBUSTIBLE AND TOXIC GASES AND OXYGEN DEFICIENCY	92
J321 LOAD, UNLOAD, OR TRANSPORT CABLE REELS	91
H241 WORK ALOFT ON METAL STRUCTURES	90
H207 FABRICATE ROLLED EYE SPLICES	87
L399 PERFORM INITIAL INSTALLATION OF BURIED CABLE USING OPEN TRENCH METHOD	84
L390 LOCATE BURIED CABLES	83
H242 WORK ALOFT ON WOOD STRUCTURES	79
L397 PERFORM INITIAL INSTALLATION OF BURIED CABLE MARKERS	77
I253 FABRICATE GUYS	70
J325 PERFORM INITIAL INSTALLATION OF FLEXIBLE COAXIAL CABLE CONNECTORS	69
H216 LAYOUT CABLE ROUTES	69
I281 PERFORM INITIAL INSTALLATION OF GUYS	68
M438 PERFORM INITIAL INSTALLATION OF UNDERGROUND TELEPHONE CABLES	66
O479 PLUMB ANTENNA SYSTEMS USING TRANSIT METHOD	65
I269 INSTALL TOWER GROUNDING SYSTEMS	62
I270 LOAD, UNLOAD, OR TRANSPORT POLES	60
I271 LOAD, UNLOAD, OR TRANSPORT TOWERS	58
O476 PERFORM INITIAL INSTALLATION OF VHF OR UHF ANTENNAS	56
I312 TENSION SUSPENSION STRANDS	55
H226 PERFORM INITIAL INSTALLATION OF LIGHTNING PROTECTION DEVICES ON ANTENNA TRANSMISSION SYSTEMS	55
H215 INTERPRET SCHEMATIC DIAGRAMS	54
O477 PERFORM INSTALLATION OF ANTENNA SYSTEMS USING RIGGING TECHNIQUES	53
T567 RAISE OR LOWER RLP ANTENNAS USING ELECTRIC WINCHES	53
J318 FORM AND ARRANGE CABLES FOR SPLICING	52

TABLE II

GROUP ID NUMBER AND TITLE: ST0039, ANTENNA MAINTENANCE CLUSTER
 GROUP SIZE: 122 PERCENT OF SAMPLE: 27%
 PREDOMINANT GRADE: E-4/E-5 AVERAGE TICF: 77 MONTHS
 AVERAGE TAFMS: 84 MONTHS

THE FOLLOWING ARE IN DESCENDING ORDER BY PERCENT MEMBERS PERFORMING:

REPRESENTATIVE TASKS	PERCENT MEMBERS PERFORMING
H241 WORK ALOFT ON METAL STRUCTURES	93
T559 INSPECT RLP ANTENNA SYSTEMS	93
H200 CLIMB POLES OR TOWERS	90
I256 INSPECT ANTENNA OR LINE SUPPORT HARDWARE	88
T563 MAINTAIN RLP ANTENNA SYSTEMS	87
J349 TROUBLESHOOT CABLE USING MULTIMETERS	87
P491 MAINTAIN LOG PERIODIC ANTENNAS	86
O469 PERFORM CORROSION CONTROL ON ANTENNA SYSTEMS	85
I257 INSPECT ANTENNA OR LINE SUPPORT STRUCTURES	85
P490 INSPECT LOG PERIODIC ANTENNAS	85
I255 INSPECT ANCHORS	84
O463 IDENTIFY OR TAG ANTENNAS	84
T560 INSPECT ROTATABLE LOG PERIODIC (RLP) ANTENNA CONTROL WIRING	83
O468 PERFORM CHECKOUT OF VERY HIGH FREQUENCY (VHF) OR ULTRA HIGH FREQUENCY (UHF) ANTENNAS	80
O466 MAINTAIN ANTENNA COMPONENTS, SUCH AS RADIATORS, PASSIVE REFLECTORS, OR ROTOR CONTROLS	79
J348 TROUBLESHOOT CABLE USING MEGGERS	78
J351 TROUBLESHOOT CABLE USING TIME DOMAIN REFLECTOMETERS	75
J339 REMOVE OR REPLACE FLEXIBLE COAXIAL CABLE CONNECTORS	74
H219 MEASURE VOLTAGE STANDING WAVE RATIOS	73
T562 MAINTAIN RLP ANTENNA ELECTRICAL COMPONENTS	72
O486 REMOVE OR REPLACE VHF OR UHF ANTENNAS	70
H218 MAINTAIN OBSTRUCTION LIGHTING SYSTEMS	67
O467 MAINTAIN OPEN WIRE TRANSMISSION LINES	66
T561 INTERPRET RLP ANTENNA ELECTRICAL SCHEMATICS	66
T574 TROUBLESHOOT RLP ANTENNA CONTROL WIRING USING MULTIMETERS	63
J341 REMOVE OR REPLACE SEMIFLEXIBLE COAXIAL CABLE CONNECTORS	63
I272 MEASURE STRAND TENSION USING CAM-LEVER DYNOMETERS	60
O479 PLUMB ANTENNA SYSTEMS USING TRANSIT METHOD	59
O465 INSPECT OR ADJUST PHOTOELECTRIC CELLS	58
O480 REMOVE OR REPLACE ANTENNA COMPONENTS, SUCH AS RADIATORS, PASSIVE REFLECTORS, OR ROTOR CONTROLS	52

TABLE III

GROUP ID NUMBER AND TITLE: ST0074, PARABOLIC ANTENNA INSTALLATION
 GROUP SIZE: 6 PERCENT OF SAMPLE: 1%
 PREDOMINANT GRADE: E-3/E-4 AVERAGE TICF: 53 MONTHS
 AVERAGE TAFMS: 55 MONTHS

THE FOLLOWING ARE IN DESCENDING ORDER BY PERCENT MEMBERS PERFORMING:

<u>REPRESENTATIVE TASKS</u>	<u>PERCENT MEMBERS PERFORMING</u>
H241 WORK ALOFT ON METAL STRUCTURES	100
S545 PERFORM INITIAL INSTALLATION OF WAVEGUIDE SUPPORTS OR MOUNTS	100
S541 PERFORM INITIAL INSTALLATION OF FLEXIBLE WAVEGUIDES	100
S543 PERFORM INITIAL INSTALLATION OF WAVEGUIDE CONNECTORS	100
S544 PERFORM INITIAL INSTALLATION OF WAVEGUIDE PRESSURIZATION SYSTEMS	100
S535 LOCATE WAVEGUIDE PRESSURE LEAKS	100
O469 PERFORM CORROSION CONTROL ON ANTENNA SYSTEMS	100
H200 CLIMB POLES OR TOWERS	83
S546 REMOVE OR REPLACE FLEXIBLE WAVEGUIDES	83
Q508 PERFORM INITIAL INSTALLATION OF PROTECTIVE SHIELDS ON PARABOLIC ANTENNAS	83
Q503 PERFORM INITIAL INSTALLATION OF FEED HORNS ON PARABOLIC ANTENNAS	83
Q502 ORIENTATE OR ALIGN PARABOLIC ANTENNAS	83
S548 REMOVE OR REPLACE WAVEGUIDE CONNECTORS	83
S547 REMOVE OR REPLACE RIGID WAVEGUIDES	83
S536 MAINTAIN FLEXIBLE WAVEGUIDES	83
S542 PERFORM INITIAL INSTALLATION OF RIGID WAVEGUIDES	83
Q505 PERFORM INITIAL INSTALLATION OF PARABOLIC ANTENNA MOUNTS	67
H237 TIE HITCHES IN FIBER ROPES	67
O463 IDENTIFY OR TAG ANTENNAS	67
O477 PERFORM INSTALLATION OF ANTENNA SYSTEMS USING RIGGING TECHNIQUES	67
S549 SEAL WAVEGUIDE PRESSURE LEAKS	67
S551 SPLICE RIGID WAVEGUIDES	67
H220 PERFORM CONSTRUCTION HAND SIGNALS	67
Q507 PERFORM INITIAL INSTALLATION OF PREASSEMBLED PARABOLIC ANTENNAS	67
O470 PERFORM INITIAL INSTALLATION OF ANTENNA COMPONENTS, SUCH AS RADIATORS, PASSIVE REFLECTORS, OR ROTOR CONTROLS	67
I253 FABRICATE GUYS	67
Q500 FABRICATE PARABOLIC ANTENNA MOUNTS	50

TABLE IV

GROUP ID NUMBER AND TITLE: ST0030, SUPERVISION CLUSTER
 GROUP SIZE: 31 PERCENT OF SAMPLE: 7%
 PREDOMINANT GRADE: E-6/E-7 AVERAGE TICF: 164 MONTHS
 AVERAGE TAFMS: 191 MONTHS

THE FOLLOWING ARE IN DESCENDING ORDER BY PERCENT MEMBERS PERFORMING:

REPRESENTATIVE TASKS	PERCENT MEMBERS PERFORMING
D109 MAINTAIN TRAINING RECORDS	87
B57 RESOLVE TECHNICAL PROBLEMS THAT PERSONNEL ARE UNABLE TO SOLVE	87
D97 COUNSEL TRAINEES ON TRAINING PROGRESS	87
B40 COUNSEL PERSONNEL ON PERSONAL OR MILITARY-RELATED MATTERS	84
C87 WRITE APRs	81
A9 DETERMINE WORK PRIORITIES	81
C82 INSPECT PERSONNEL FOR COMPLIANCE WITH MILITARY STANDARDS	77
A26 PLAN OR SCHEDULE WORK ASSIGNMENTS	74
D94 CONDUCT OJT	74
D91 ANNOTATE TRAINING RECORDS	74
B53 INITIATE ACTION TO CORRECT SUBSTANDARD PERFORMANCE OF PERSONNEL	74
B55 INTERPRET POLICIES, DIRECTIVES, OR PROCEDURES FOR SUBORDINATES	71
A27 PLAN OR SCHEDULE WORK PRIORITIES	68
D106 EVALUATE PERSONNEL FOR TRAINING NEEDS	68
A6 COORDINATE WORK WITH APPROPRIATE PERSONNEL OR AGENCIES	68
B39 CONDUCT SUPERVISORY ORIENTATIONS OF NEWLY ASSIGNED PERSONNEL	68
A21 ESTABLISH PERFORMANCE STANDARDS FOR SUBORDINATES	65
B59 SUPERVISE ANTENNA/CABLE SYSTEMS MAINTENANCE SPECIALISTS (AFSC 36150)	65
A22 ESTABLISH WORK METHODS OR CONTROLS	65
D98 COUNSEL TRAINERS ON TRAINING RESPONSIBILITIES	61
D92 ASSIGN ON-THE-JOB TRAINING (OJT) TRAINERS	61
C88 WRITE RECOMMENDATIONS FOR AWARDS AND DECORATIONS	58
D110 MONITOR EFFECTIVENESS OF UPGRADE TRAINING, SUCH AS CAREER KNOWLEDGE, JOB PROFICIENCY, AND QUALIFICATION TRAINING	58
B52 IMPLEMENT WORK METHODS	58
A1 ASSIGN PERSONNEL TO DUTY POSITIONS	58
A7 DETERMINE LOGISTICS REQUIREMENTS, SUCH AS SPACE, PERSONNEL, OR EQUIPMENT	58
A2 ASSIGN PROJECTS, MAINTENANCE, AND REPAIR WORK	52

TABLE V

GROUP ID NUMBER AND TITLE: ST0029, QUALITY ASSURANCE
 GROUP SIZE: 5 PERCENT OF SAMPLE: 1%
 PREDOMINANT GRADE: E-7 AVERAGE TICF: 188 MONTHS
 AVERAGE TAFMS: 198 MONTHS

THE FOLLOWING ARE IN DESCENDING ORDER BY PERCENT MEMBERS PERFORMING:

<u>REPRESENTATIVE TASKS</u>	<u>PERCENT MEMBERS PERFORMING</u>
F142 WRITE INSPECTION REPORTS	100
F140 REVIEW OR INSPECT COMMUNICATIONS ELECTRONIC FACILITY RECORDS (CEFR)	100
C73 EVALUATE PERSONNEL FOR COMPLIANCE WITH PERFORMANCE STANDARDS OR TECHNICAL ORDERS	100
F136 PERFORM IN PROGRESS INSPECTIONS	100
F135 PERFORM FINAL INSPECTIONS	100
F137 PREPARE OR PROCESS QUALITY ASSURANCE (QA) OR QUALITY CONTROL (QC) FORMS	100
F134 PERFORM ACTIVITY INSPECTIONS	80
F141 UPDATE CEFRs	80
C82 INSPECT PERSONNEL FOR COMPLIANCE WITH MILITARY STANDARDS	80
A12 DEVELOP INSPECTION PROCEDURES	80
C79 IDENTIFY PROBLEM AREAS USING DEFICIENCY OR SERVICE REPORTS	60
C68 EVALUATE MAINTENANCE AND INSPECTION REPORT FINDINGS	60
F133 EVALUATE TECHNICAL ORDER SYSTEM PUBLICATION DEFICIENCY REPORTS	60
F131 EVALUATE MAINTENANCE OR INSTALLATION PROGRAMS PERFORMED BY MILITARY CONTRACTORS	60
F139 REVIEW OR ASSEMBLE DATA ON SYSTEMS OR EQUIPMENT FAILURE	60
A15 DEVELOP QUALITY ASSURANCE PROGRAMS	60
B49 IMPLEMENT SELF-INSPECTION PROGRAMS	60
C66 EVALUATE CAUSES OF MISSION OPERATIONAL DISCREPANCIES	40
C83 INVESTIGATE ACCIDENTS OR INCIDENTS	40
C75 EVALUATE SAFETY OR SECURITY PROGRAMS	40
C81 INSPECT MAINTENANCE ACTIONS	40
A18 DEVELOP SELF-INSPECTION PROGRAMS	40
C70 EVALUATE MAINTENANCE MANAGEMENT INFORMATION AND CONTROL SYSTEMS (MMICS), SUCH AS REPORTS OR LISTINGS	40
C67 EVALUATE EQUIPMENT MODIFICATION DATA	40

TABLE VI

GROUP ID NUMBER AND TITLE: ST0066, TRAINING
 GROUP SIZE: 7 PERCENT OF SAMPLE: 1%
 PREDOMINANT GRADE: E-5 AVERAGE TICF: 111 MONTHS
 AVERAGE TAFMS: 126 MONTHS

THE FOLLOWING ARE IN DESCENDING ORDER BY PERCENT MEMBERS PERFORMING:

<u>REPRESENTATIVE TASKS</u>	<u>PERCENT MEMBERS PERFORMING</u>
D114 SCORE TESTS	100
D90 ADMINISTER TESTS	86
D115 WRITE TEST QUESTIONS	86
D95 CONDUCT RESIDENT COURSE CLASSROOM TRAINING	71
I244 ERECT POLES USING CRANE METHOD	57
H202 DIG POLE HOLES USING POWER EQUIPMENT	43
D97 COUNSEL TRAINEES ON TRAINING PROGRESS	43
H200 CLIMB POLES OR TOWERS	43
I246 ERECT POLES USING LINE TRUCK METHOD	43
C82 INSPECT PERSONNEL FOR COMPLIANCE WITH MILITARY STANDARDS	29
H213 INSPECT WINCHES	29
I310 REMOVE POLES USING POLE DERRICK AND POLE JACK METHOD	29