

DWG FILE COPY

2

PSYCHOSOCIAL RISK FACTORS  
FOR UPPER RESPIRATORY INFECTION:  
DEPRESSION AS A MEDIATOR OF ASSOCIATIONS  
BETWEEN NEUROTICISM AND  
UPPER RESPIRATORY ILLNESS\*

AD-A223 192

Best Available Copy

R. R. VICKERS, JR.  
L. K. HERVIG

20030211007

REPORT NO. 89-13

Approved for public release: distribution unlimited.

NAVAL HEALTH RESEARCH CENTER  
P.O. BOX 85122  
SAN DIEGO, CALIFORNIA 92138

NAVAL MEDICAL RESEARCH AND DEVELOPMENT COMMAND  
BETHESDA, MARYLAND



Psychosocial Risk Factors for Upper Respiratory Infection:  
 DEPRESSION AS A MEDIATOR OF ASSOCIATIONS BETWEEN NEUROTICISM  
 AND UPPER RESPIRATORY ILLNESS\*

Ross R. Vickers, Jr.  
 Linda K. Hervig

Operational Performance Department  
 Naval Health Research Center  
 P. O. Box 85122  
 San Diego, CA 92138-9174



Accession For	
NTIS GRA&I	<input checked="" type="checkbox"/>
DTIC TAB	<input checked="" type="checkbox"/>
Unannounced	<input type="checkbox"/>
Justification	
By _____	
Distribution/	
Availability Codes	
Dist	Avail and/or Special
A-1	

\*Technical Report 89-13 supported by the Naval Medical Research and Development Command, Navy Medical Command, Department of the Navy, under Research Work Unit MRO4101.00A-6004. The views presented are those of the authors and do not reflect the official policy of the Department of the Navy, Department of Defense, nor the U. S. Government.

## SUMMARY

Upper respiratory infections are commonplace among military personnel in training or operational environments. Although these infections typically produce mild, self-limiting disease, laboratory evidence indicates they can substantially impair cognitive and physical performance, and, therefore, contribute to a substantial number of "walking wounded" in operational settings. The development of methods of reducing the effects of infectious disease will progress more rapidly if high risk individuals can be identified for study to carefully delineate the processes of disease susceptibility as a precursor to development of interventions targeted on specific deficiencies. Prior research supports anecdotal observations that neurotic tendencies are related to higher incidence of illness under stress, presumably because adverse psychological reactions to stress activate physiological systems in ways that impair immune function. The present study contrasted this possibility with an alternative model that assumed that personality-URI relationships were purely psychological in character. If the latter hypothesis were true, personality traits would have little value for the objective of identifying high risk individuals. JFM

Two samples of U. S. Navy recruits ( $n = 130$  and  $n = 253$ ) who volunteered to participate in a study of risk factors for infectious disease completed personality measures at the beginning of basic training. At the same time, these recruits completed a standardized inventory to measure the extent of depression during the preceding week. Symptom reports of URI then were obtained at weekly intervals during the first month of basic training, a time known to involve high rates of URI. Analysis of covariance structure procedures were employed to compare alternative models. The alternatives focused on the contrast between models that assumed that observed covariances were the product of purely psychological processes and models that assumed the existence of covariance mediated by biological processes.

The findings demonstrated that psychological processes did explain a substantial part of the covariation between personality and URI, but did not explain all of this covariation. Instead, a reliable pathway from personality to depression to URI was identified which was independent of

general symptom reporting tendencies. The magnitude of the effects in this pathway was modest, but consistent with reasonable expectations.

The present findings must be considered in context for an appropriate interpretation. There is substantial evidence that URI symptom reports are valid indicators of disease. Also, depression is known to be related to immune functioning. Finally, the present findings are based on analyses which help rule out purely psychological processes as the underlying basis for the observed associations. Thus, it is reasonable to infer that personality does influence disease in stressful situations by mechanisms which include modification of immune system processes. The effect is not a large one, a finding which could be predicted from knowledge of the number of intervening steps in the hypothesized causal sequence, but even relatively modest effects can cumulate to significant performance implications when considered over a large number of individuals in a given setting or considered over time for a given individual. Further work to identify the immunological mechanisms involved in the causal pathway is justified. The knowledge of personality factors indirectly implicated in these causal pathways can help focus attention on specific individuals to study to obtain this information in the most efficient fashion.

## INTRODUCTION

Evidence that psychological factors correlate with immunocompetence (Jemmott & Locke, 1984) suggests that a psychobiological model may be appropriate for any disease influenced by immunological processes. This assertion includes infectious diseases which have received relatively little attention in psychobiological research (Plaut & Friedman, 1981). The present paper, therefore, tests the hypothesis that emotional reactions to stress are an intervening mechanism between personality and actual illness in the case of infectious disease. The specific test of the hypothesis examines the relationships between neuroticism, depression, and upper respiratory illness (URI) in U. S. Navy recruits during basic training.

The central research hypothesis in this study rests on several prior empirical observations and assumptions. First, personality attributes are stable over time (Conley, 1984; Costa & McCrae, 1988; Helson & Moane, 1987; Leon, Gillum, Gillum & Gouze, 1979), and, therefore, are logically unlikely to precipitate specific disease occurrences. Second, personality predicts emotional states (Costa & McCrae, 1980; Tellegen, 1982; Watson, 1988a). Third, emotional reactions are related to biological parameters that may link stress to illness, including immunological functioning (Heisel, Locke, Kraus & Williams, 1986; Irwin, Daniels, Bloom, Smith & Weiner, 1987; Irwin, Daniels, Bloom & Weiner, 1986; Irwin, Daniels, Smith, Bloom & Weiner, 1987; Kiecolt-Glaser, Fisher, et al., 1987; Kiecolt-Glaser, Ricker, et al., 1984; Locke, et al., 1984). Finally, an indirect effect of personality on susceptibility to infection could explain why past attempts to relate personality to infectious disease have produced results which cumulatively suggest a weak association (Broadbent, Broadbent, Phillpotts & Wallace, 1984; Evans, Pitts & Smith, 1988; Graham, Douglas & Ryan, 1986; Greenfield, Roessler & Crosley, 1959; Imboden, Canter & Cluff; 1961; Jackson, et al., 1960; Jacobs, Spilken, Norman & Anderson, 1970; Rose, Jenkins & Hurst, 1978; Totman, Kiff, Reed & Craig, 1980; Vickers & Hervig, 1988b; Voors, Rytel, Jenkins, Pierce & Stewart, 1969).

A stronger prediction is provided by two elaborations of the basic hypothesis. The first elaboration adds Thoits' (1984) assertion that emotional reactions are an element in all pathways from psychological precursors to disease. The second elaboration adds Watson and Tellegen's (1985) claim that two general dimensions, positive and negative mood,

adequately represent mood and, by extension, summarize all of the potential intervening mood states which could be considered with respect to Thoits' (1984) hypothesis. These two elaborations produce a stronger prediction regarding personality-disease associations when it is recognized that they imply that any causal pathway from a psychological precursor to infectious disease must include either positive or negative affect at some point. It follows mathematically that controlling for positive and negative affect, any relationships between personality and disease will be reduced to zero except for sampling error (Glymour, Scheines, Spirtes & Kelly, 1987; Kivii & Speed, 1982).

In the present instance, predictions about personality-disease relationships can be further strengthened by considering the personality correlates of the specific disease criterion of interest. Upper respiratory illness (URI) was chosen as the infectious disease criterion, because URI is the most common type of infectious disease in a young, healthy population such as that being studied (Verbrugge, 1986), has substantial personal and social costs as a result (Harlan, et al., 1986), and is known to be common in the setting being studied (Arlander, Pierce, Edwards, Peckinpaugh & Miller, 1965; Edwards & Rosenbaum, 1971). Prior studies which have included comprehensive coverage of the five robust dimensions of personality have shown that neurotic tendencies are the only reliable predictors of URI in the population being investigated (Vickers & Hervig, 1988b). Neuroticism, in turn, is related to negative affect, but not to positive affect (Costa & McCrae, 1980; Tellegen, 1982; Watson, 1988a). Thus, combining the several considerations outlined above leads to the specific prediction that neuroticism and URI will have zero covariation after controlling for negative affect. Depression was chosen to represent negative affect for the purposes of testing this prediction, because this emotion is central to the general construct of negative affect (Watson, Clark & Tellegen, 1988) and is related to immune functions that may influence infectious diseases (Heisel, et al., 1986; Irwin, Daniels, Bloom, et al., 1986; 1987; Irwin, Daniels, Smith, et al., 1987, Kiecolt-Glaser, Fisher, et al., 1987; Kiecolt-Glaser, Ricker, et al., 1984; Locke, et al., 1984).

The conclusions derived from a test of the foregoing hypothesis could be inaccurate if no consideration were given to alternative models which would predict the same findings. One such alternative is provided by recent

suggestions that personality-disease relationships are the product of purely psychological processes affecting symptom reporting, decisions to seek health care, and similar illness measures, but unrelated to real disease pathology (Costa & McCrae, 1987; Watson, 1988a). This formulation challenges psychobiological models which assume that personality-disease relationships are the product of processes involving pathophysiology. In the case of infectious disease, demonstrated relationships between psychological factors and indicators of immune system function provide plausible physiological mechanisms for a truly psychobiological association, but it still is desirable to determine whether invoking somatizing or hypochondriacal tendencies as explanations can account for personality-disease associations.

The foregoing considerations led to tests of the alternative explanatory models shown in Figure 1 as possible representations of neuroticism-URI associations. These models were tested by relating neuroticism and depression to URI in recruits during U. S. Navy basic training, because basic training involves substantial adaptational demands (Zurcher, 1968), established patterns of emotional reactions to these demands (Datei & Engle, 1966; Datei, Engle & Barba, 1966; LaRocco, Biersner & Ryman, 1975) that appear to be related to biological functioning (Rose, Poe & Mason, 1968; Vickers, Hervig, Wallick, Poland & Rubin, 1987). Also, URI is most common following the peak of negative emotions (Arlander, et al., 1965; Edwards & Rosenbaum, 1971), so the timing of affect relative to illness is appropriate for testing the hypotheses of interest. Basic training also standardizes many aspects of daily living, thereby reducing the likelihood of biased parameter estimates arising from unmeasured causes of URI (James, Mulaik & Brett, 1982). Thus, tests of the models in Figure 1 using data from basic training were judged likely to produce interpretable results.

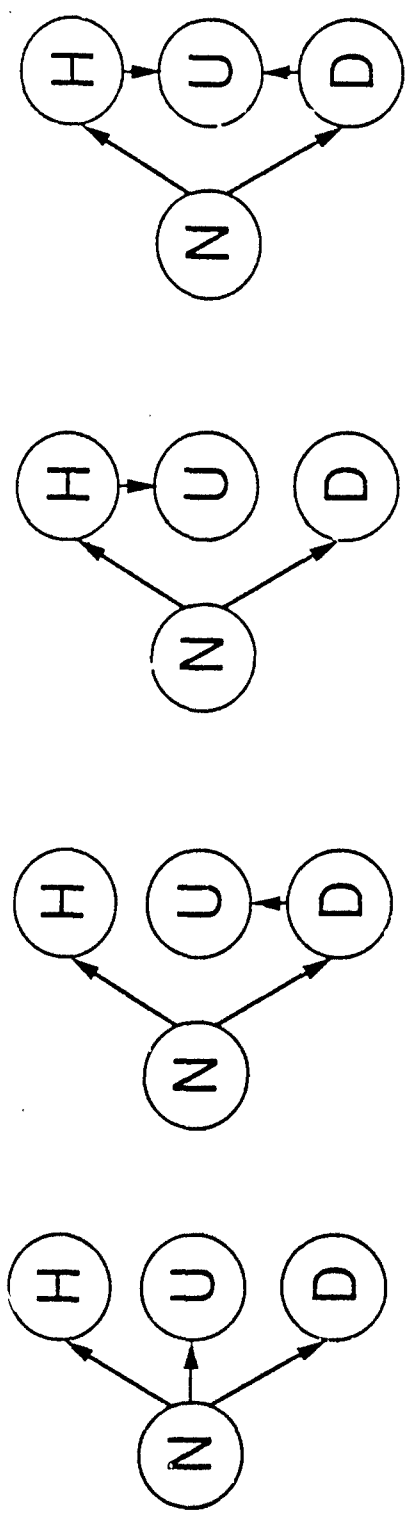

MODEL 1                      MODEL 2                      MODEL 3                      MODEL 4

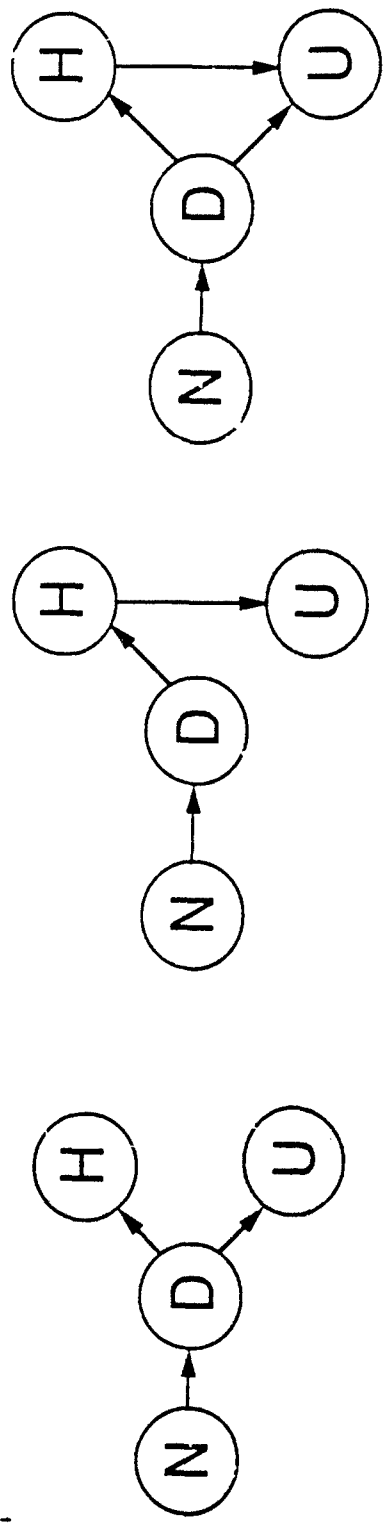

MODEL 5                      MODEL 6                      MODEL 7

Figure 1  
Alternative Explanatory Models  
NOTE: N= Neuroticism; H= Hypochondriasis; U= Upper Respiratory Infection; D= Situational Depression. Arrows Indicate Postulated Causal Effects.

## METHOD

### Sample

Two samples of recruits volunteered to participate after the study was described to them. The average recruit in the first sample (n = 130) was 19.3 years of age (S.D. = 2.7; range = 17-33). The great majority of the recruits had a high school diploma (91%) or Graduate Equivalence Degree (2%), but a few had failed to complete high school (7%). The primary ethnic group was Caucasian (70%) with substantial minorities of Hispanics (11%) and Blacks (13%). The average recruit in the second sample (n = 253) was 19.0 years of age (S.D. = 2.8; range = 17-33 years). Again, most recruits had a high school diploma (90%) or Graduate Equivalence Degree (5%), but a few failed to complete high school (5%). The primary ethnic group again was Caucasian (74%) with substantial minorities of Hispanics (9%) and Blacks (11%).

### Personality Measures

The NEO Personality Inventory (Costa & McCrae, 1985) was chosen to measure personality, because it is a well-standardized instrument designed to measure five robust dimensions of personality which have been proposed as a comprehensive representation of the personality domain with established multitrait-multimethod validation of the measures (McCrae & Costa, 1987) and appropriate correlations to other established measures of the major personality dimensions of neuroticism and extraversion (e.g., McCrae & Costa, 1985). Additional details on the bases for selecting this instrument are given by Vickers and Hervig (1988b). However, only the scales related to neuroticism were utilized in this study. When neuroticism is considered as an overall dimension, high scores identify individuals who are "...prone to psychological distress, unrealistic ideas, excessive cravings or urges, and maladaptive coping responses." The components of this general dimension are measured by scales for six specific personality facets: (a) Anxiety, indicated by endorsement of items describing one's self as tense or worried versus calm or stable; (b) Hostility, indicated by endorsement of items describing one's self as hot-tempered or easily-frustrated versus amiable or slow to take offense; (c) Depression, indicated by endorsement of items describing one's self as hopeless or guilty versus seldom sad or feels worthwhile; (d) Self-Consciousness, indicated by endorsement of items describing one's self as ashamed or easily embarrassed versus poised or

secure; (e) Impulsiveness, indicated by endorsement of items describing one's self as yielding to urges or cravings versus self-controlled; (f) Stress Vulnerability, indicated by endorsement of items describing one's self as easily rattled or unable to deal with stress versus resilient or cool-headed. Each of these primary personality attributes was measured by an 8-item scale briefly described in Table 1.

Table 1  
Descriptive Statistics for Neuroticism and Depression Indicators

	Sample A			Sample B		
	Alpha	Mean	S.D.	Alpha	Mean	S.D.
<u>Neuroticism Indicators</u>						
Anxiety	.71	2.06	.63	.74	1.90	.62
Hostility	.64	1.89	.61	.76	1.80	.65
Depression	.81	2.04	.75	.75	1.87	.68
Self-Consciousness	.54	2.14	.54	.65	2.03	.57
Impulsiveness	.53	2.28	.50	.65	2.19	.52
Stress Vulnerability	.67	1.50	.52	.78	1.46	.56
<u>Situational Depression Indicators</u>						
Negative Affect	.85	2.16	.80	.85	2.05	.75
Functional Disruption	.62	2.37	.62	.72	2.11	.62
Social Isolation	.47	1.84	.82	.67	1.97	.82
Unhappiness	.64	2.94	.96	.59	2.67	.89
Hopelessness	.59	1.72	.73	.50	1.73	.69

#### Situational Depression Indicators

The 20-item Center for Epidemiological Studies Depression (CES-D; Radloff, 1977) Scale measured depressive symptomatology. This instrument was constructed to include items representing major categories of depressive symptoms (Levitt, Lubin & Brooks, 1983). These categories include experience of negative affect, functional disruption, impaired social functioning, and absence of positive affect.

Five item composites were used as indicators of situational depression. Factor analyses of the CES-D in samples of the general U. S. civilian population typically identify 3 or 4 basic dimensions in this instrument (Berkman, et al., 1986; Ensel, 1986; Kuo, 1984; Radloff, 1977;

Ying, 1988). Factor analyses of data from 3 Navy recruit samples, including those providing the data reported here, suggested that in this population and setting, four dimensions were appropriate, but the specific dimensions did not correspond exactly to the dimensions found in prior studies. In particular, a low positive affect dimension typically found in four-factor solutions could be split into "unhappiness" and "hopelessness." At the same time, factors representing negative affect and functional disruption, which typically are found in four-dimensional solutions, collapsed to form a single factor.

A decision was made to employ the set of depression composites described in Table 1 to operationalize the latent trait of situational depression. One justification for this decision was that the distinction between hopelessness and unhappiness may have theoretical importance (Beck, 1967). A second justification was that the phenomenological representation of a psychological construct can vary across settings and populations despite essential constancy of the construct in question (Blalock, 1982), so light inconsistencies between the present population and other samples should not be a major concern. The final justification was that the intent of the development of composites was to provide a small number of depression indicators that encompassed the full range of symptoms to provide adequate operational indicators for the latent trait of depression. The selected set met this objective as the five scales covered major areas of depressive symptomatology. Negative Affect (items 3, 6, 10, 14, 17, and 18) assessed feelings such as sadness, depression, and loneliness. Functional Disruption (items 1, 2, 5, 7, 11, 13, and 20) assessed the perception that common daily functions were more difficult, requiring a great deal of effort with trouble concentrating and loss of appetite and sleep problems. Social Isolation (items 15 and 19) assessed feelings of being disliked and that people were unfriendly. Unhappiness (items 12 and 16) assessed the absence of positive emotion, particularly relative to past times. Hopelessness (items 4, 8, and 9) reflected the perception of failure and not looking forward to tasks with reason to expect success.

#### Illness Assessment

Symptom reports were obtained at data collections sessions conducted 12, 19, and 26 days after beginning training for approximately 50 percent of the participants. The remaining participants completed the same reports two

days later, because of a weekend that intervened between the beginning of training and the day of training for which data collections were scheduled. This schedule was the closest possible approximation to a weekly assessment feasible within the constraints of the training schedule.

At each session recruits indicated the severity of each symptom over the preceding three days of basic training using response options ranging from "Not at all severe" (1) to "Extremely severe" (5). URI was assessed by an 8-item composite of the responses to questions asking about fever, sore throat, dry cough, productive cough, stuffed-up nose, sneezing, hoarseness, and sinus pain. Raw scores were adjusted for the influence of concurrent reports of allergy and musculoskeletal illnesses by applying correction factors developed by Vickers and Hervig (1988a).

The working definition of hypochondriasis assumed that psychological factors affecting symptom reporting would produce nonspecific increases in symptom reporting independent of true pathological processes. Operationally, this tendency, which was labelled "situational hypochondriasis" to emphasize the presumably transient character of the symptoms actually measured, was represented by a composite consisting of responses to items concerning skin irritation, vomiting, diarrhea, and trouble hearing, as described by Vickers and Hervig (1988a). These symptoms were previously shown to be infrequent in basic training, and, with the possible exception of vomiting and diarrhea, did not appear to represent any common illness syndrome. Vomiting and diarrhea no doubt co-occur in some illnesses, such as gastrointestinal infections, but these two symptoms are infrequent in conjunction with respiratory infections in both military and civilian populations (Forsyth, Bloom, Johnson & Chanock, 1963; Gwaltney, Hendley, Simon & Jordan, 1967) and were weakly related empirically in four large samples of recruits, as described by Vickers and Hervig (1988a). In fact, in this population, both symptoms were more strongly related to trouble hearing than to each other. Given the generally low frequency of occurrence and the relative independence of the four symptoms it seemed reasonable to assume that high scores on the situational hypochondriasis composite would occur only among individuals who had a strong tendency to report nonspecific symptoms.

### Analysis Procedures

Preliminary analyses describing frequency distributions and the reliability of the individual marker variables measured to represent the latent traits and bivariate associations between these marker variables were computed with the Statistical Package for the Social Sciences (SPSSx; SPSS, 1983). No exceptional problems with the score distributions were noted, and the bivariate associations were comparable to those obtained in previous samples of U. S. Navy recruits. The assumption was made that relationships between variables were linear, because extensive attempts to identify nonlinearity in relationships in prior work had produced uniformly negative findings (Vickers & Hervig 1988b,c).

Structural equation models were evaluated with LISREL VI (Joreskog & Sorbom, 1981). A null model and a saturated model were added to the models illustrated in Figure 1 to provide a frame-of-reference for evaluating the overall goodness-of-fit of the substantive models. The null model assumed that all latent traits were independent. The saturated model assumed that neuroticism influenced the other three latent traits, but was not reciprocally affected. Depression, URI, and hypochondriasis were assumed to have reciprocal causal relationships. This latter model was saturated in the sense that it contained all the causal associations between the constructs that were considered plausible on the basis of prior research and the proposed theoretical interpretations of the constructs of interest. A unidirectional effect of personality on the remaining variables was assumed based on evidence that individual differences in personality are stable over extended periods of time which doubtless encompass many minor episodes of acute dysphoria and illness for the normal individual. Reciprocal associations between the remaining constructs were considered plausible when the hypothesized causal effects of interest in the models being tested were combined with potentially competing interpretations of the measures employed. An effect of depression on URI was a central research hypothesis, but negative mood also could be a prodromal indicator of illness (Hoeplich & Boggs, 1983). An effect of hypochondriasis also was expected, but true illness could alter general sensitivity to symptoms, thereby inducing a situational hypochondriasis. This assumption could explain why the range of symptoms which have been reported in conjunction with viral infections includes many nonspecific symptoms (cf., Vickers & Hervig, 1988a. for a

review of the symptoms which have been linked to viral infections). Finally, Aneshensel, Frerichs, and Huba (1984) demonstrated reciprocal effects between depression and general physical complaints suggesting the possibility of reciprocal relationships between depression and the hypochondriasis construct in this study.

The null and saturated models define a constrained range of possible chi-square values for explanatory models. All alternative models must be comprised of a subset of the causal effects hypothesized in the saturated model and must consist of at least one effect to differentiate them from the null model. When combined, therefore, the saturated and null models define a range of chi-square values that is a useful frame of reference for evaluating goodness-of-fit (Bentler & Bonett, 1980). Comparisons between models have been expressed in terms of chi-squares, the adjusted goodness-of-fit index of Joreskog and Sorbom (1981), the Bentler-Bonnet (1980) index, and the Tucker-Lewis index (Tucker & Lewis, 1973). The Bentler-Bonett index was chosen, because it is designed specifically to compare nested models. The Tucker-Lewis index was chosen, because recent evidence suggests it is less sensitive to sample size than alternative measures of goodness-of-fit for structural models (Marsh, Balla & McDonald, 1988). The chi-squares have been reported, because they provide a basis for estimating the statistical significance of differences in goodness-of-fit. The adjusted goodness-of-fit from LISREL has been reported, because it is a standardized measure available as standard information from the analysis package. The Bentler-Bonett index was chosen because it confined comparisons to a restricted range of chi-square values encompassing the competing alternatives describing associations between latent traits with the assumption that the measurement models for these traits had been correctly specified. Some misfit related to measurement misspecification had to be expected, but this misfit was not a critical concern as long as the measurement model provided appropriate evaluation of the latent traits of interest. It was desirable, therefore, to exclude the portions of the overall chi-square attributable to imperfect measurement models from the evaluations to avoid confounding this problem with inappropriate specification of the relationships between latent traits. Separate Bentler-Bonett indices were computed with the Null Model and Model 1 of Figure 1 as the reference models, because Bentler and Bonett (1980) suggest that the "null" model should be the simplest theoretically

defensible model rather than a true null model in the sense of one that assumes no associations. A single latent trait of neuroticism seemed appropriate from that perspective, but a true null model, in the sense of no associations between the latent traits also provides an informative point of reference. The Bentler-Bonett indexes derived with the alternative null models are referred to as BBI1 and BBI2 in the presentation of results. The Tucker-Lewis index was chosen as a final basis for model comparison based on recent simulation studies indicating this index is relatively unaffected by sample size, a factor which may be a problem for many other indices of fit (Marsh, et al., 1988). The Tucker-Lewis index also has the advantage of indicating the goodness-of-fit of the overall model, including the measurement model, to the total covariance matrix while the Bentler-Bonett index concentrates on a more constrained set of issues pertaining, in this instance, solely to the improvement in fit attributable to the various combinations of associations between the latent traits.

## RESULTS

### Test for Equality of Covariance Matrices

Comparison of the covariance matrices for the two groups using procedures described by Joreskog and Sorbom (1981, pp. V.7-V.12) indicated the matrices were reasonably comparable (chi-square, 153 df, = 251.65,  $p < .001$ ) applying recommended accepted chi-square/degrees-of-freedom ratios as standards for goodness-of-fit (Carmines & McIver, 1981). Hoelter's (1983) critical  $n$  was 288, well above his recommended value of 200 for concluding that the fit of a model is acceptable. The two groups, therefore, were combined for tests of specific models.

### Goodness-of-Fit Tests for Best Fitting Models

The six explanatory models in Figure 1 could be divided into three groups based on fit to the data (Table 2). Models 2 and 5, which omitted effects of hypochondriasis on URI, produced trivial improvement in goodness-of-fit relative to either "null" model and were not considered further.

Table 2  
Model Comparison Summary

Model	df	Chi-Square	Goodness-of-Fit Index:			
			AGFI	BBI1	BBI2	T-L
Null	119	561.37	.823	----	----	----
1	116	339.38	.879	.683	----	.482
2	116	336.00	.882	.693	.033	.490
3	116	247.59	.906	.965	.891	.695
4	115	237.61	.909	.996	.987	.713
5	116	333.63	.881	.691	.027	.488
6	116	246.71	.906	.968	.899	.697
7	115	237.12	.909	.998	.992	.714
Sat.	110	236.32	.907	----	----	----

NOTE: "Sat." refers to the saturated model described in the analysis procedures. AGFI = Joreskog and Sorbom's (1981) Adjusted Goodness of Fit Index, BBI = Bentler-Bonett Index computed relative to Model 1 (BBI1) or Model 2 (BBI2), and T-L = Tucker and Lewis (1973) index. See Figure 1 for details of the specific models compared.

The key findings for the remaining model comparisons involved contrasts between Models 3 and 4 and between Models 6 and 7. In each case, the contrast compared models which differed only in that the latter model added an effect of depression on URI to the former model. Model 4 produced a significant improvement in goodness-of-fit relative to Model 3 (chi-square, 1 df, = 9.98), and Model 7 produced a comparable improvement relative to Model 6 (chi-square, 1 df, = 9.59). Models 4 and 7 were closely comparable in terms of goodness-of-fit, and both fit the data nearly as well as the saturated model.

Although the primary reason for including the saturated model was to provide a point of reference for evaluating other models, the computations for this model generated estimates of the effects of URI and Situational Hypochondriasis on Situational Depression. These coefficients were small negative values (-.03 or less). The magnitude of these associations, their signs, and the slight, statistically nonsignificant, differences in goodness-of-fit between the saturated and Model 4 or Model 7 provided justification for regarding causal effects of URI on psychological status as inconsistent with the data.

### Structural Coefficient Estimates for Selected Models

Standardized structural coefficient estimates for Models 4 and 7 were closely comparable (Figure 2). For clarity of presentation, the figure has been limited to associations between the latent traits. Information regarding the measurement model coefficients has been provided in Appendix A.

The fact that each model included a significant effect of depression on URI independent of hypochondriasis, was a noteworthy element of Figure 2, even though the absolute magnitude of these effects was small. The standardized solution was chosen over the raw coefficients, because the raw coefficients will be affected by scaling parameters unique to the specific measures employed in this study. The standardized parameters, therefore, may be a better representation of results that can be expected in other settings with different operational measures of the constructs being investigated. A substantial effect of neuroticism on depression was common to both models. Note that neither model included a direct effect of neuroticism on URI controlling for situational depression. Adding this effect would have produced an improvement in the chi-square goodness-of-fit of 1.30 or less, even if it accounted for all the difference between the reported models and the saturated model.

### Tests for Cross-Sample Consistency of Specific Parameters

Additional analyses assessed the cross-sample consistency of the causal effects in Figure 2 to ensure that the overall test for equality of covariance matrices (see p. 11) was not insensitive to sample differences in specific covariances important for model estimation. This possibility was considered, because the overall test might have combined a few systematic differences in covariance with many random sources of difference to produce an overall test indicating generally acceptable comparability.

Models 4 and 7 were re-evaluated with separate LISREL estimates for each sample. Removing the constraint that latent variable associations were equal in the two groups improved the goodness-of-fit only slightly for each model (Model 4, chi-square = 1.37; Model 7, chi-square = 1.51, 4 df for each). The only path coefficient that varied much was that between situational hypochondriasis and URI (.57 versus .77), but the difference was less than twice the standard error for this coefficient (S.E. = .11 or

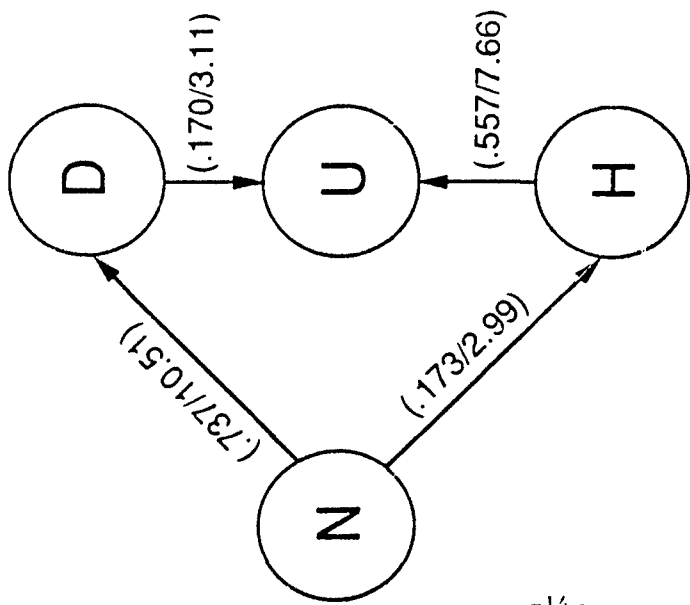

Model 4

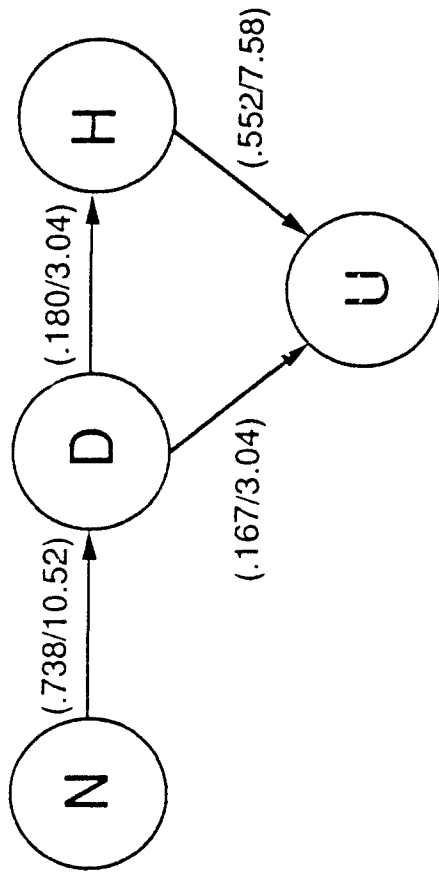

Model 7

Figure 2

Coefficients For Selected Explanatory Models

NOTE: N= Neuroticism; H= Hypochondriasis; U= Upper Respiratory Infection; D= Depression. Arrows Indicate Postulated Causal Effects. Numbers in Parentheses Are Standardized Path Coefficients And Associated T-Values. See Appendix A For Details Of Measurement Models.

larger in both groups). Thus, there was no evidence of substantial variation in parameter estimates across groups.

#### DISCUSSION

The major conclusion from the present study was that a model which assumes that all causal pathways from neuroticism to URI are mediated by negative affect can reproduce the observed personality-depression-URI associations. Also, situationally-induced depressive affect probably is more strongly related to URI than is personality, but the difference is modest. The estimated correlation between the latent variable indicators of depression and URI was .17 for Model 4 and .27 for Model 7. When this value is combined with the effect of neuroticism on depression, which was .73 in both models, the estimated effect of neuroticism on URI is .12 for Model 4 and .19 for Model 7. These values are quite close to the average partial correlation between URI and neuroticism controlling for general symptom reporting (partial  $r = .11$ ) obtained in a prior study by averaging results over three samples of recruits. Thus, the present results are consistent with prior observations, thereby indicating their generality.

The relatively modest magnitude of the depression-URI association in the present study might be a concern for psychobiological models of infectious disease. This slight association implies that psychological factors have relatively little effect on disease outcomes, but the size of the observed association may be affected by the specific measure of depression chosen for study. The CES-D was quite strongly related to neuroticism, a fact which suggests that this measure is comprised of substantial trait variance, an interpretation supported by several reports of temporal stability coefficients in the .40 to .60 range over periods of 2 to 6 months (Avison & Turner, 1988; Ensel, 1986; Lewinsohn, Hoberman & Rosenbaum, 1988; Radloff, 1977). A subset ( $n = 60$ ) of the participants in Sample A of this study who completed the CES-D scale at the end of basic training produced a correlation of .52 with an estimated correlation of .69 between the latent traits when LISREL procedures were used with a measurement model corresponding to that employed here. While this stability is modest relative to some psychological variables, it is substantially higher than reported day-to-day changes in mood measured by mood

questionnaires (Watson, 1988b). Affective measures which are more sensitive to acute mood states may be better predictors of URI, assuming that acute emotional reactions produce concomitant immune system changes which provide a window of opportunity for infections. This possibility merits investigation, although prior studies have produced equivocal findings regarding acute mood changes relative to the onset of infections (Evans, Pitts & Smith, 1988; Luborsky, Mintz, Brightman & Katcher, 1976).

The modest observed depression-URI association also is consistent with theories that assume that several causal steps intervene between emotion and illness. Consider a sequence in which depression influences the immune system which in turn modifies pathophysiological effects (in individuals with infections) that finally produce symptoms. The observed depression-URI association would be produced by this hypothesized sequence if the standardized path coefficient was approximately .53 at each of these steps. Thus, the modest association may be the product of several moderately large intervening effects.

Given the foregoing argument, it is important to emphasize that the observed association can be interpreted reasonably as evidence for a true link between personality and pathology. One basis for this claim is prior evidence that symptom reports are highly related to clinical judgements of health status based on observations of gross physical pathology (Roden, 1958; Totman, et al., 1980) and to physiological markers for pathological processes associated with infections (Naclerio, et al., 1988; Totman, Reed & Craig, 1977) and to pre-existing antibodies prior to viral exposure (Broadbent, et al., 1984; Totman, et al., 1977). Symptom report measures also clearly distinguish inoculated and placebo groups in controlled studies of viral inoculations (e.g., Jackson, Dowling, Spiesman & Board, 1958) and are sensitive to pharmacological interventions intended to modify the physiological bases of symptoms (Curley, et al., 1988; Howard, et al., 1979). Symptom report measures also are related to biochemical markers which may be related to general susceptibility to respiratory infections (Jemmott, 1987; Lytle & McNamara, 1967; Lytle, Rytel & Edwards, 1966; Rossen, et al., 1970; Yodfat & Silvian, 1977). Furthermore, the present study followed the recommended clinical practice of ruling out allergy as a source of reported symptoms (Lowenstein & Parrino, 1987) and included controls for possible biases arising from hypochondriasis. The estimated

association between URI and depression was about 20 per cent smaller when the explanatory model included an effect of hypochondriasis on URI, supporting Costa and McCrae's (1987) contention that this is an important potential source of bias in personality-illness estimates, but a significant association remained despite this control.

Closer consideration of the temporal sequence of events suggests an alternative interpretation of the findings that should be studied more closely in the future. Experimental inoculation of healthy individuals with viruses typically produces symptoms 1 to 7 days later (e.g., Jordan, 1962; Roden, 1963) with 2 to 5 days later the accepted representative interval (Evans, 1982). Once symptoms occur, they usually are resolved within two weeks, but an estimated 25 per cent of colds extend beyond this period (Gwaltney, 1985; Roden, 1963). It is a common clinical observation that negative affect can be a prodromal indicator of infectious disease (Hoepflich & Boggs, 1983), so the observed URI-depression associations might represent the lagged development of different URI indicators. If so, the apparent causal effect of depression on susceptibility to infection would be in question, but the conclusion that personality is a risk factor would not be affected. Under this alternative interpretation, the association of personality to prodromal depression would be one expression of the link between personality and URI, but the psychological mechanisms by which personality influences URI onset would remain indeterminate. Note that the results do not contradict Aneshensel, Frerich and Huba's (1984) report of reciprocal effects linking depression and illness, because the temporal sequence of the depression and illness measures precluded an evaluation of reciprocal effects in this study.

The preceding arguments provide reason to believe that neuroticism is related to susceptibility to naturally-acquired viral infections, but the clinical significance of the findings is uncertain. The weak associations noted here would require substantial associations between symptoms and time lost from work or work effectiveness, before they implied significant short term social costs associated with acute illness. However, even weak personality-URI associations would be important if they repeated regularly over multiple time intervals to produce substantial cumulative health differences or a higher probability of hospitalization due to the increased probability of severe illness arising from more frequent illnesses or to

periods of increased susceptibility to secondary infections which significantly increase the risk of severe infectious disease (e.g., Edwards, Devine, Sengbusch & Ward, 1977). Ultimately, the absolute size of the personality-depression-URI association may be less important than its consistency across time and situations. Even modest differences between individuals observed at a given time can rapidly cumulate to substantial personal, social, and economic consequences in some cases (Abelson, 1985). These issues must be investigated to arrive at a final conclusion regarding the importance of personality for infectious disease susceptibility.

#### REFERENCES

- Abelson, R.P. (1985). A variance explanation paradox: When a little is a lot. Psychological Bulletin, 97, 129-133.
- Aneshensel, C.S., Frerichs, R.R., & Huba, G.J. (1984). Depression and physical illness: a multiwave, nonrecursive causal model. Journal of Health and Social Behavior, 25, 350-371.
- Arlander, T.R., Pierce, W.E., Edwards, E.A., Peckinpugh, R.O., & Miller, L.F. (1965). IV. An epidemiologic study of respiratory illness patterns in Navy and Marine Corps recruits. American Journal of Public Health, 55, 67-80.
- Avison, W.R., & Turner, R.J. (1988). Stressful life events and depressive symptoms: Disaggregating the effects of acute stressors and chronic strains. Journal of Health and Social Behavior, 29, 253-264.
- Beck, A.T. (1967). Depression. Philadelphia: University of Pennsylvania Press.
- Berkman, L.F., Berkman, C.S., Kasl, S., Freeman, D.H., Leo, L., Ostfeld, A.M., Cornoni-Huntley, J., & Brody, J.A. (1986). Depressive symptoms in relation to physical health and functioning in the elderly. American Journal of Epidemiology, 124, 372-388.
- Bentler, P.M., & Bonett, D.G. (1980). Significance tests and goodness of fit in the analysis of covariance structures. Psychological Bulletin, 88, 588-606.
- Blalock, H.M., Jr. (1982). Conceptualization and Measurement in the Social Sciences. Beverly Hills, CA: Sage.
- Broadbent, D.E., Broadbent, M.H.P., Phillpotts, R.J., & Wallace, J. (1984). Some further studies on the prediction of experimental colds in volunteers by psychological factors. Journal of Psychosomatic Research, 28, 511-523.
- Carmines, E.G., & McIver, J.P. (1981). Analyzing models with unobserved variables: Analysis of covariance structures. In W.G. Bohrnstedt and E.F. Borgatta (eds.), Social Measurement: Current Issues. Beverly Hills, CA: Sage.
- Conley, J.J. (1984). The hierarchy of consistency: A review and model of longitudinal findings on adult individual differences in intelligence, personality and self-opinion. Personality and Individual Differences, 5, 11-25.
- Costa, P.T., Jr., & McCrae, R.R. (1980). Influence of extraversion and neuroticism on subjective well-being: Happy and unhappy people. Journal of Personality and Social Psychology, 38, 668-678.
- Costa, P.T., Jr., & McCrae, R.R. (1985). NEO Personality Inventory Manual. Odessa, FL: Psychological Assessment Resources, Inc.

- Costa, P.T., Jr., & McCrae, R.R. (1987). Neuroticism, somatic complaints, and disease: is the bark worse than the bite? Journal of Personality, 55, 299-316.
- Costa, P.T., Jr., & McCrae, R.R. (1988). Personality in Adulthood: A 6-year Longitudinal Study of Self-Reports and Spouse Ratings on the NEO Personality Inventory. Journal of Personality and Social Psychology, 54, 853-863.
- Curley, F.J., Irwin, R.S., Pratter, M.R., Stivers, D.H., Doern, G.V., Vernaglia, P.A., Larkin, A.B., & Baker, S.P. (1988). Cough and the common cold. American Review of Respiratory Disease, 138, 305-311.
- Datel, W.E., & Engle, E.O. (1966). Affect levels in another platoon of basic trainees. Psychological Reports, 19, 407-412.
- Datel, W.E., Engle, E.O., & Barba, M.A. (1966). Affect levels in a company of basic trainees. Psychological Reports, 19, 903-909.
- Edwards, E.A., Devine, L.F., Sengbusch, C.H., & Ward, H.W. (1977). Immunological investigations of meningococcal disease. III. Brevity of Group C acquisition prior to disease occurrence. Scandinavian Journal of Infectious Disease, 9, 105-110.
- Edwards, E.A., & Rosenbaum, M.J. (1971). Surveillance Program: 1964-1970. Great Lakes, IL: Naval Medical Research Unit No. 4, Report RU 71.17.
- Ensel, W.M. (1986). Measuring depression: the CES-D scale. In N. Lin, A. Dean & W. Ensel (eds.), Social Support, Life Events, and Depression. Orlando, FL: Academic Press, pp. 51-70.
- Evans, A.S. (1982). Epidemiological concepts and methods. In A.S. Evans (ed.), Viral Infections of Humans. Epidemiology and Control. N.Y.: Plenum, pp. 1-42, esp. pp. 16-17.
- Evans, P.D., Pitts, M.K., & Smith, K. (1988). Minor infection, minor life events and the four day desirability dip. Journal of Psychosomatic Research, 32, 533-539.
- Forsyth, B.R., Bloom, H.H., Johnson, K.M., & Chanock, R.M. (1963). Patterns of illness in rhinovirus infections of military personnel. New England Journal of Medicine, 269, 602-606.
- Glymour, C., Scheines, R., Spirtes, P., & Kelly, K. (1987). Discovering Causal Structure: Artificial Intelligence, Philosophy of Science, and Statistical Modeling. N.Y.: Academic Press.
- Graham, N.M., Douglas, R.M., & Ryan, P. (1986). Stress and acute respiratory infection. American Journal of Epidemiology, 124, 389-401.
- Greenfield, N.S., Roessler, R., & Crosley, A.P. (1959). Ego strength and length of recovery from infectious mononucleosis. Journal of Nervous and Mental Disease, 128, 125-128.

- Gwaltney, J.M., Jr. (1985). The common cold. In G.L. Mandell, R.D. Douglas, Jr., J.E. Bennett (eds.), Principles and Practice of Infectious Diseases. Second Edition. N.Y.: Wiley, pp. 351-355.
- Gwaltney, J.M., Jr., Hendley, J.O., Simon, G., & Jordan, W.S., Jr. (1967). Rhinovirus infections in an industrial population. II. Characteristics of illness and antibody response. Journal of the American Medical Association, 202, 158-164.
- Harlan, W.R., Murt, H.A., Thomas, J.W., Lepkowski, J.M., Guire, K.E., Berki, S.E., & Landis, J.R. (1986). Incidence, utilization, and costs associated with acute respiratory conditions, United States, 1980. National Medical Care Utilization and Expenditure Survey. Series C, Analytical Report No. 4. DHHS Publication No. 86-20404. National Center for Health Statistics, Public Health Service. Washington: U.S. Government Printing Office, Sept., 1986.
- Heisel, J.S., Locke, S.E., Kraus, L.J., & Williams, R.M. (1986). Natural killer cell activity and MMPI scores of a cohort of college students. American Journal of Psychiatry, 143, 1382-1386.
- Helson, R., & Moane, G. (1987). Personality change in women from college to midlife. Journal of Personality and Social Psychology, 53, 176-186.
- Hoelter, J.W. (1983). The analysis of covariance structures. Goodness-of-fit indices. Sociological Methods and Research, 11, 325-344.
- Hoeprich, P.D., & Boggs, D.R. (1983). Manifestations of infectious diseases. In P.D. Hoeprich (ed.), Infectious Diseases, Third Edition. N.Y.: Harper & Row, p. 85.
- Howard, J.C., Kantner, T.R., Lilienfield, L.S., Princiotto, J.V., Krum, R.E., Crutcher, J.E., Belman, M.A., & Danzig, M.R. (1979). Effectiveness of antihistamines in the symptomatic management of the common cold. Journal of the American Medical Association, 242, 2414-2417.
- Imboden, J.B., Canter, A., & Cluff, L.E. (1961). Convalescence from influenza: a study of the psychological and clinical determinants. Archives of Internal Medicine, 108, 393-399.
- Irwin, M., Daniels, M., Bloom, E.T., Smith, T.L., & Weiner, H. (1987). Life events, depression, and immune function. American Journal of Psychiatry, 144, 437-441.
- Irwin, M., Daniels, M., Bloom, E., & Weiner, H. (1986). Life events, depression, and natural killer cell activity. Psychopharmacology Bulletin, 22, 1093-1096.
- Irwin, M., Daniels, M., Smith, T.L., Bloom, E., & Weiner, H. (1987). Impaired natural killer cell activity during bereavement. Brain, Behavior, and Immunity, 1, 98-104.

- Jackson, G. L., Dowling, H.F., Anderson, T.O., Riff, L., Saporta, J., & Turck, M. (1950). Susceptibility and immunity to common upper respiratory viral infections--the common cold. Annals of Internal Medicine, 3, 719-738.
- Jackson, G.G., Dowling, H.F., Spiesman, M.O., & Board, A.V. (1958). Transmission of the common cold to volunteers under controlled conditions. I. The common cold as a clinical entity. Archives of Internal Medicine, 101, 267-278.
- Jacobs, M.A., Spilken, A.Z., Norman, M.M., & Anderson, L.S. (1970). Life stress and respiratory illness. Psychosomatic Medicine, 32, 233-242.
- James, L.R., Mulaik, S.A., & Brett, J.M. (1982). Causal Analysis: Assumptions, Models, and Data. Beverly Hills, CA: Sage.
- Jemmott, J.B., III. (1987). Social motives and susceptibility to disease: Staking individual differences in health risks. Journal of Personality, 55, 267-298.
- Jemmott, J.B., & Locke, S.E. (1984). Psychosocial factors, immunologic mediation, and human susceptibility to infectious diseases: How much do we know. Psychological Bulletin, 95, 78-108.
- Jordan, W.S. (1962). Acute respiratory diseases of viral etiology. I. Ecology of respiratory viruses -- 1961. American Journal of Public Health, 52, 897-902.
- Joreskog, K.G., & Sorbom, D. (1981). LISREL User's Guide. Chicago: International Educational Services.
- Kiecolt-Glaser, J.K., Fischer, L.D., Ogrocki, P., Stout, J.C., Speicher, C.E., & Glaser, R. (1987). Marital quality, marital disruption, and immune function. Psychosomatic Medicine, 49, 13-34.
- Kiecolt-Glaser, J.K., Ricker, D., George, J., Messick, G., Speicher, C.E., Garner, W., & Glaser, R. (1984). Urinary cortisol levels, cellular immunocompetency, and loneliness in psychiatric inpatients. Psychosomatic Medicine, 46, 15-23.
- Kivii, H., & Speed, T.P. (1982). Structural analysis of multivariate data: A review. In S. Leinhardt (ed.), Sociological Methodology, 1982. San Francisco: Jossey-Bass, 209-289.
- Kuo, W.H. (1984). Prevalence of depression among Asian-Americans. Journal of Nervous and Mental Disease, 172, 449-457.
- LaRocco, J.M., Biersner, R.J., & Ryman, D.H. (1975). Mood effects of large group counseling among navy recruits. Journal of Counseling Psychology, 22, 127-131.

- Leon, G.R., Gillum, B., Gillum, R., & Gouze, M. (1979). Personality stability and change over a 30 year period-middle age to old age. Journal of Consulting and Clinical Psychology, 47, 517-524.
- Levitt, E.E., Lubin, B., & Brooks, J.M. (1983). Depression: Concepts, Controversies, and Some New Facts (Second Edition). Hillsdale, NJ: Erlbaum.
- Lewinsohn, P.M., Hoberman, H.M., & Rosenbaum, M. (1988). A prospective study of risk factors for unipolar depression. Journal of Abnormal Psychology, 97, 251-264.
- Locke, S.E., Kraus, L., Leserman, J., Hurst, M.W., Heisel, J.S., & Williams, R.M. (1984). Life change stress, psychiatric symptoms, and natural killer cell activity. Psychosomatic Medicine, 46, 441-453.
- Lowenstein, S.R., & Parrino, T.A. (1987). Management of the common cold. Advances in Internal Medicine, 32, 207-233.
- Luborsky, L. Mintz, J., Brightman, V.J., & Katcher, A.H. (1976). Herpes simplex virus and moods: A longitudinal study. Journal of Psychosomatic Research, 20, 543-548.
- Lytle, R.I., & McNamara, M.J. (1967). Ipha-1 globulins in those susceptible to viral acute respiratory diseases. Great Lakes, IL: Naval Medical Research Unit No. 4, December, 1967.
- Lytle, R.I., Rytel, M.W., & Edwards, E.A. (1966). Correlation of immunological and biological factors in the host with susceptibility to respiratory infections. Journal of Infectious Diseases, 116, 67-74.
- Marsh, H.W., Balla, J.R., & McDonald, R.P. (1988). Goodness-of-fit indexes in confirmatory factor analysis: The effect of sample size. Psychological Bulletin, 103, 391-410.
- McCrae, R.R., & Costa, P.T., Jr. (1985). Comparison of EPI and psychoticism scales with measures of the five factor model of personality. Personality and Individual Differences, 6, 587-597.
- McCrae, R.R., & Costa, P.T., Jr. (1987). Validation of the five factor model of personality across instruments and observers. Journal of Personality and Social Psychology, 52, 81-90.
- Naclerio, R.M., Proud, D., Lichtenstein, L.M., Kagey-Sobotka, A.K., Henley, J.O., Sorrentino, J., & Gwaltney, J.M. (1988). Kinins are generated during experimental rhinovirus colds. Journal of Infectious Diseases, 157, 133-142.
- Plaut, S.M., & Friedman, S.B. (1981). Psychosocial factors in infectious disease. In R. Ader (ed.), Psychoneuroimmunology. N.Y.: Academic Press, pp. 3- 30.

- Radloff, L.S. (1977). The CES-D Scale: A self-report depression scale for research in the general population. Applied Psychological Measurement, 1, 385-401.
- Roden, A.T. (1958). Clinical assessment of the common cold. Proceedings of the Royal Society for Medicine, 51, 271-273.
- Roden, A.T. (1963). Variations in the clinical pattern of experimentally induced colds. Journal of Hygiene, 61, 231-246.
- Rose, R.M., Jenkins, C.D., & Hurst, M.W. (1978). Air Traffic Controller Health Change Study. Boston: Boston University School of Medicine, pp. 511-513.
- Rose, R.M., Poe, R.O., & Mason, J.W. (1968). Psychological state and body size as determinants of 17-OHCS excretion. Archives of Internal Medicine, 121, 406-413.
- Rossen, R.D., Butler, W.T., Waldman, R.H., Alford, R.H., Hornick, R.B., & Togo, Y. (1970). The proteins in nasal secretions. II. A longitudinal study of IgA and neutralizing antibody levels in children. Journal of the American Medical Association, 211, 1157-1161.
- Statistical Package for the Social Sciences (SPSS. (1983). SPSSx Statistical Algorithms. Chicago: SPSS, Inc.
- Tellegen, A. (1982). Brief manual for the Differential Personality Questionnaire. Unpublished manuscript, University of Minnesota, Minneapolis, MN.
- Thoits, P.A. (1984). Coping, social support, and psychological outcomes; The central role of emotion. In P. Shaver (ed.), Review of Personality and Social Psychology, Volume 5. Beverly Hills, CA: Sage Publications, pp. 219-238.
- Totman, R., Kiff, J., Reed, S.E., & Craig, J.W. (1980). Predicting experimental colds in volunteers from different measures of recent life stress. Journal of Psychosomatic Research, 24, 155-163.
- Totman, R., Reed, S.E., & Craig, J.W. (1977). Cognitive dissonance, stress and virus-induced common colds. Journal of Psychosomatic Research, 21, 55-63.
- Tucker, L.R., & Lewis, C. (1973). The reliability coefficient for maximum likelihood factor analysis. Psychometrika, 38, 1-10.
- Verbrugge, L.M. (1986). From sneezes to adieux: Stages of health for American men and women. Social Science and Medicine, 22, 1195-1212.
- Vickers, R.R., Jr., & Hervig, L.K. (1988a). Psychosocial risk factors for infectious disease: Assessment of upper respiratory illness during basic training (Report No. 88-23). San Diego, CA: Naval Health Research Center.

- Vickers, R.R., Jr., & Hervig, L.K. (1988b). Psychosocial risk factors for infectious disease: Personality predictors of URI during basic training (Report No. 88-36). San Diego, CA: Naval Health Research Center.
- Vickers, R.R., Jr., & Hervig, L.K. (1988c). Psychosocial risk factors for upper respiratory infection: Self-monitoring, self-consciousness, and symptom report accuracy (Report No. 88-37). San Diego, CA: Naval Health Research Center.
- Vickers, R.R., Jr., Hervig, L.K., Wallick, M.T., Poland, R.E., & Rubin, R.T. (1987). Psychological correlates of cortisol excretion in normal individuals under stress (Report No. 87-1). San Diego, CA: Naval Health Research Center.
- Voors, A.W., Rytel, M.W., Jenkins, C.D., Pierce, W.E., & Stewart, G.T. (1969). Prediction of sickness in naval recruits by Minnesota Multiphasic Personality Inventory scores. American Review of Respiratory Disease, 99, 420-425.
- Watson, D. (1988a). Intraindividual and interindividual analyses of positive and negative affect: Their relation to health complaints, perceived stress, and daily activities. Journal of Personality and Social Psychology, 54, 1020-1030.
- Watson, D. (1988b). The vicissitudes of mood measurement: Effects of varying descriptors, time frames, and response formats on measures of positive and negative affect. Journal of Personality and Social Psychology, 55, 128-141.
- Watson, D., Clark, L.A., & Tellegen, A. (1988). Development and validation of brief measures of positive and negative affect: The PANAS scales. Journal of Personality and Social Psychology, 54, 1063-1070.
- Watson, D., & Tellegen, A. (1985). Toward a consensual structure of mood. Psychological Bulletin, 98, 219-235.
- Ying, Y-W. (1988). Depressive symptomatology among Chinese-Americans as measured by the CES-D. Journal of Clinical Psychology, 44, 733-738.
- Yodfat, Y., & Silvian, I. (1977). A prospective study of acute respiratory tract infections among children in a kibbutz: The role of secretory IgA and serum IgA. Journal of Infectious Diseases, 136, 26-30.
- Zurcher, L.A. (1968). The naval recruit training center: A study of role assimilation in a total institution. Sociological Inquiry, 31, 85-98.

Appendix A

Measurement Model Coefficients for Latent Trait Indicators

	<u>LISREL</u> <u>Estimate</u>	<u>t-</u> <u>Value</u>	<u>Standardized</u> <u>Coefficient</u>
<u>Neuroticism Indicators</u>			
Anxiety	.489	17.50	.489
Hostility	.286	8.96	.286
Depression	.608	20.61	.608
Self-Consciousness	.418	16.49	.418
Impulsiveness	.228	8.67	.228
Stress Vulnerability	.413	16.93	.413
<u>Situational Depression</u> <u>Indicators</u>			
Negative Affect	.454	15.67	.672
Functional Disruption	.306	13.54	.453
Social Isolation	.260	8.67	.385
Unhappiness	.349	10.41	.516
Hopelessness	.272	10.78	.403
<u>Hypochondriasis Indicators</u>			
Hypochondriasis 2	.202	10.03	.205
Hypochondriasis 3	.379	18.93	.385
Hypochondriasis 4	.252	14.53	.257
<u>Upper Respiratory Illness</u> <u>Indicators</u>			
URI 2	.264	9.01	.332
URI 3	.446	12.00	.559
URI 4	.241	9.41	.302

NOTE: The numbers "2," "3," and "4," after Hypochondriasis and URI identify the data collection sessions providing the measure used as an indicator. Values in the table were taken from Model 7. These values differed by at most .002 from those obtained in Model 4, thereby indicating that the measurement model was highly stable, despite differences in the assumed relationships among latent traits.

REPORT DOCUMENTATION PAGE

1a REPORT SECURITY CLASSIFICATION Unclassified			1b RESTRICTIVE MARKINGS N/A		
2a SECURITY CLASSIFICATION AUTHORITY N/A			3 DISTRIBUTION/AVAILABILITY OF REPORT Approved for public release; distribution unlimited.		
2b DECLASSIFICATION/DOWNGRADING SCHEDULE N/A					
4 PERFORMING ORGANIZATION REPORT NUMBER(S) NHRC Report No. 89-13			5 MONITORING ORGANIZATION REPORT NUMBER(S)		
6a NAME OF PERFORMING ORGANIZATION Naval Health Research Center		6b OFFICE SYMBOL (if applicable) 10	7a NAME OF MONITORING ORGANIZATION Commander Naval Medical Command		
6c ADDRESS (City, State, and ZIP Code) P.O. Box 85122 San Diego, CA 92138-9174			7b ADDRESS (City, State, and ZIP Code) Department of the Navy Washington, DC 20372		
8a NAME OF FUNDING/SPONSORING ORGANIZATION Naval Medical Research & Development Command		8b OFFICE SYMBOL (if applicable)	9 PROCUREMENT INSTRUMENT IDENTIFICATION NUMBER		
8c ADDRESS (City, State, and ZIP Code) NMC NCR Bethesda, MD 20814-5044			10 SOURCE OF FUNDING NUMBERS		
		PROGRAM ELEMENT NO 661157p	PROJECT NO MR04101	TASK NO .00A	WORK UNIT ACCESSION NO 6004
11 TITLE (Include Security Classification) Psychosocial Risk Factors for Upper Respiratory Infection: Depression as a Mediator of Associations between Neuroticism and Upper Respiratory Illness					
12 PERSONAL AUTHOR(S) Vickers, Ross R., Jr. and Hervig, Linda K.					
13a TYPE OF REPORT Interim		13b TIME COVERED FROM _____ TO _____		14 DATE OF REPORT (Year, Month, Day) 1989 March 31	15 PAGE COUNT
16 SUPPLEMENTARY NOTATION					
17 COSATI CODES			18 SUBJECT TERMS (Continue on reverse if necessary and identify by block number) Depression Navy men Personality LISREL Upper Respiratory Illness		
FIELD	GROUP	SUB-GROUP			
19 ABSTRACT (Continue on reverse if necessary and identify by block number)  The present study demonstrated that associations between the personality trait of neuroticism and upper respiratory illness in U.S. Navy recruits could be explained by assuming that neurotic personality contributed to negative emotional states which increase the risk of illness. Statistical controls for hypochondriacal tendencies coupled with the established validity of URI symptom reports and prior demonstrations of negative emotion-immune system relationships provide reason to believe the observed associations are the product of a causal path linking personality to true disease with immunosuppression as an intervening variable.					
20 DISTRIBUTION/AVAILABILITY OF ABSTRACT <input type="checkbox"/> UNCLASSIFIED/UNLIMITED <input checked="" type="checkbox"/> SAME AS RPT <input type="checkbox"/> DTIC USERS			21 ABSTRACT SECURITY CLASSIFICATION Unclassified		
22a NAME OF RESPONSIBLE INDIVIDUAL Vickers, Ross R., Jr.			22b TELEPHONE (Include Area Code) (619) 553-8454	22c OFFICE SYMBOL 10	