

DTIC FILE COPY

(4)

GL-TR-99-0047(I)

Studies of Ionospheric Dynamics  
Utilizing Data From DMSP

R. A. Heelis  
M. R. Hairston

University of Texas at Dallas  
Center for Space Sciences  
Richardson, TX 75083

22 February 1990

Final Report  
1 January 1987-31 December 1989

APPROVED FOR PUBLIC RELEASE; DISTRIBUTION UNLIMITED

GEOPHYSICS LABORATORY  
AIR FORCE SYSTEMS COMMAND  
UNITED STATES AIR FORCE  
HANSCOM AIR FORCE BASE, MASSACHUSETTS 01731-5000

DTIC  
ELECTE  
JUN 26 1990  
S E D  
Co

AD-A223 370

90 06 25 160

"This Technical report has been reviewed and is approved for publication"

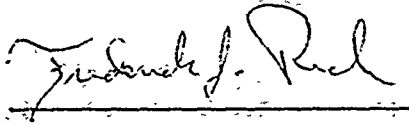

FREDERICK J. RICH  
Contract Manager



NELSON C. MAYNARD  
Branch Chief

FOR THE COMMANDER

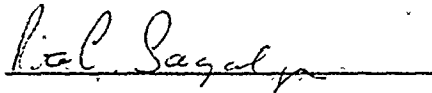

RITA C. SAGALYN  
Division Director

This report has been reviewed by the ESD Public Affairs Office (PA) and is releasable to the National Technical Information Service (NTIS).

Qualified requestors may obtain additional copies from the Defense Technical Information Center. All others should apply to the National Technical Information Service.

If your address has changed, or if you wish to be removed from the mailing list, or if the addressee is no longer employed by your organization, please notify GL/IMA, Hanscom AFB, MA 01731. This will assist us in maintaining a current mailing list.

Do not return copies of this report unless contractual obligations or notices on a specific document requires that it be returned.

unclassified

SECURITY CLASSIFICATION OF THIS PAGE (When Data Entered)

REPORT DOCUMENTATION PAGE		READ INSTRUCTIONS BEFORE COMPLETING FORM
1. REPORT NUMBER GL-TR-90-0047 (I)	2. GOVT ACCESSION NO.	3. RECIPIENT'S CATALOG NUMBER
4. TITLE (and Subtitle) Studies of ionospheric dynamics utilizing data from DMSP	7. AUTHOR  R. A. Heelis and M. R. Hairston	5. TYPE OF REPORT & PERIOD COVERED FINAL REPORT 1 Jan 87-31 Dec 89
		6. PERFORMING ORG. REPORT NUMBER
9. PERFORMING ORGANIZATION NAME AND ADDRESS Center for Space Sciences University of Texas at Dallas Richardson, Texas 75083-0688	8. CONTRACT OR GRANT NUMBER(s)  F19628-87-K-0014	
11. CONTROLLING OFFICE NAME AND ADDRESS Geophysics Laboratory Hanscom AFB, Massachusetts 01731-5000 Contract Manager: Fred Rich/PHG	10. PROGRAM ELEMENT, PROJECT, TASK AREA & WORK UNIT NUMBERS 61102F 2311G5AD	
	12. REPORT DATE 22 February 1990	
14. MONITORING AGENCY NAME & ADDRESS (if different from Controlling Office)	13. NUMBER OF PAGES 44	
	15. SECURITY CLASS. (of this report) unclassified	
15a. DECLASSIFICATION/DOWNGRADING SCHEDULE		
16. DISTRIBUTION STATEMENT (of this Report) approved for public release; distribution unlimited		
17. DISTRIBUTION STATEMENT (of the abstract entered in Block 20, if different from Report)		
18. SUPPLEMENTARY NOTES		
19. KEY WORDS (Continue on reverse side if necessary and identify by block number)  Ionosphere Ionospheric plasma convection pattern Plasma convection modelling DMSP satellite		
20. ABSTRACT (Continue on reverse side if necessary and identify by block number) This report covers the period 1987 to 1989 during which time our efforts have been primarily devoted to the reduction of ion drift meter data from the DMSP satellite. This work has required the development of sophisticated algorithms to generate in-situ ion drift velocity data with respect to the spacecraft and the derivation of an electrostatic potential distribution along the spacecraft track. This initial effort has been directed toward satisfying the needs of mathematical models of the high-latitude convection pattern, with some effort devoted to the improvement of the formulations currently in use. In this		

DD FORM 1 JAN 73 1473 EDITION OF 1 NOV 65 IS OBSOLETE

unclassified

SECURITY CLASSIFICATION OF THIS PAGE (When Data Entered)

UNCLASSIFIED

SECURITY CLASSIFICATION OF THIS PAGE (When Data Entered)

20. report <sup>we</sup> discuss <sup>the</sup> rationale for the preparation of data bases of the ion drift velocity and derived parameters from the DMSP data. The function of this computer code is described in detail to allow other users to make use of its capabilities.

unclassified

SECURITY CLASSIFICATION OF THIS PAGE (When Data Entered)

CONTENTS

1. INTRODUCTION . . . . . 1

2. PHYSICS OF THE HIGH-LATITUDE IONOSPHERE . . . . . 1

3. INSTRUMENTS ON BOARD DMSP . . . . . 7

4. DETAILED DESCRIPTION OF THE PROGRAM . . . . . 12

    4.1 BLOCK 1: DATA INPUT . . . . . 13

    4.2 SUBROUTINE COROTFIX . . . . . 18

    4.3 BLOCK 2: CALCULATION OF THE ELECTROSTATIC POTENTIAL . . . . . 20

    4.4 BLOCK 3: ANALYSIS OF THE ELECTROSTATIC POTENTIAL . . . . . 24

    4.5 BLOCK 4: SAVING THE DATA . . . . . 31

5. CONCLUSION AND FUTURE WORK . . . . . 32

APPENDIX A: COROTATION CORRECTION ALGORITHM . . . . . 34

REFERENCES . . . . . 38

APPENDIX B: COMPLETE LISTING OF THE ALGORITHM TO CALCULATE POTENTIAL  
(DMSPPOTMOD2.FOR) . . . . . Vol. 2

Accession For	
NTIS GRA&I	<input checked="" type="checkbox"/>
DTIC TAB	<input type="checkbox"/>
Unannounced	<input type="checkbox"/>
Justification	
By _____	
Distribution/ _____	
Availability Codes	
Dist	Special
A-1	



## 1.0 INTRODUCTION

This report covers our efforts to reduce the ion drift meter data from the DMSP F8 and F9 satellites. This work has focused on the development of sophisticated algorithms to generate in-situ ion drift velocity with respect to the spacecraft and the derivation of an electrostatic potential distribution along the spacecraft track. This initial effort has been directed toward satisfying the needs of mathematical models of the high latitude convection pattern, with some effort devoted to improvement of the formulations currently in use. This work has required the generation of computer generated data bases for use by UTD and by other interested scientists, as well as the production of visualization aids to ensure adequate data quality and proper interpretation of the data.

In this report we discuss the rationale for the preparation of data bases of the ion drift velocity and derived parameters from the DMSP data. The function of the computer code is described in detail to allow other users to make use of its capabilities. Application of the results in terms of global convection models is also described together with possible extensions of the techniques and future uses of the data base.

## 2.0 PHYSICS OF THE HIGH-LATITUDE IONOSPHERE

A primary source of energy driving the ionospheric and magnetospheric phenomenon is the interaction of the solar wind with the Earth's magnetic field. In the absence of any external forces, the Earth's magnetic field would be a simple dipole with its field lines extending out indefinitely. However, the force of the solar wind (the hot plasma continuously being emitted from the sun) compresses the magnetic field on the dayside and extends it on the nightside, thus giving the

Earth's magnetosphere the shape of a comet (figure 1). The magnetosphere blocks most of the solar wind plasma and its magnetic field from reaching the Earth. However, the flow of the solar wind past the magnetosphere induces a large electrostatic potential drop (20–200 kV) across the magnetosphere, which induces a potential drop across the high latitude ionosphere. This potential drop drives large scale plasma convection and currents inside of the magnetosphere and in the ionosphere. The magnitudes and configurations of this potential drop and these currents depend on the geometry of the Earth's magnetosphere and the orientation of the interplanetary magnetic field (IMF) embedded in the solar wind. When the IMF has a southward ( $B_z < 0$  in solar-magnetospheric coordinates) orientation it is possible for the magnetic field lines of the IMF to connect directly to the Earth's magnetic field lines, but the field lines only map to small regions near the magnetic poles (figure 2a). These regions where the Earth's field lines are open (i.e., they connect out to the IMF rather than close back to the Earth) are referred to as the polar cap regions. When the IMF turns northward ( $B_z > 0$ ) in orientation the magnetic merging on the dayside slows down or stops. If this orientation persists for several hours, then the magnetosphere evolves into a configuration where there is no direct connection between the IMF and the field lines of the Earth. (figure 2b). These configurations are referred to as the "open" and "closed" magnetosphere.

For the case when the IMF is southward, the anti-sunward flow of the field lines connected to the polar regions results in an anti-sunward flow of the ionospheric plasma in the polar regions. A returning sunward flow of the ionospheric plasma occurs at latitudes below the polar regions on closed field lines. Thus a large two-cell convection pattern is set up in the ionosphere of each hemisphere during southward IMF conditions (figure 3). The boundary between the open field lines of the polar region and the lower latitude closed field lines forms a rough circle centered on the magnetic pole. The open/closed boundary is approximately co-located with the locus

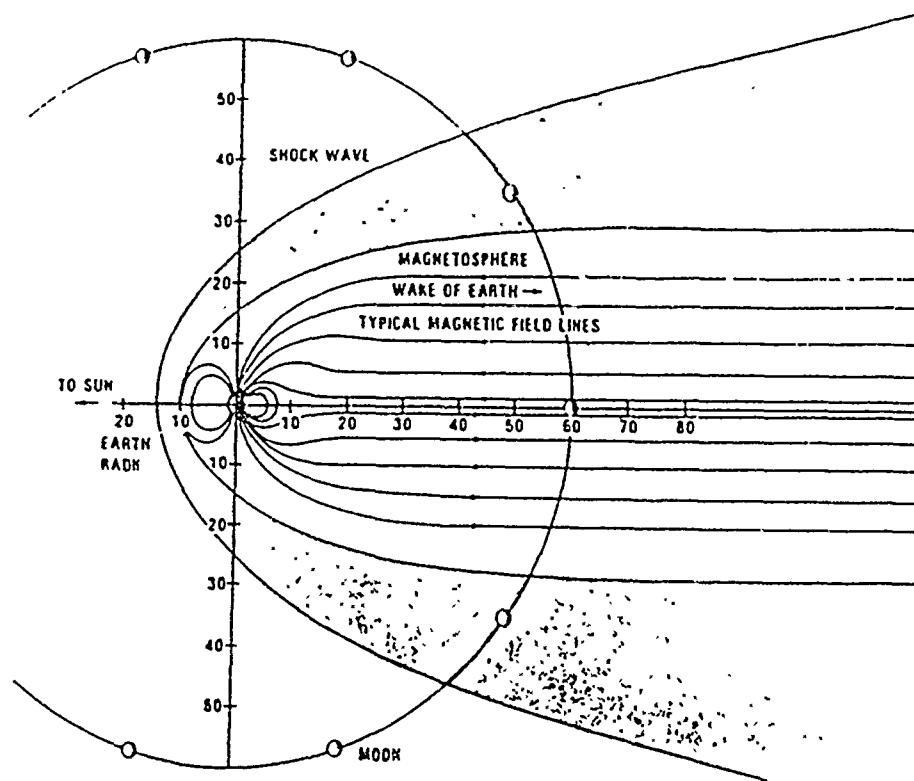

Figure 1. A simple schematic of the Earth's magnetosphere and the solar wind with the orbit of the moon added to scale. (from *Tascione*, 1988)

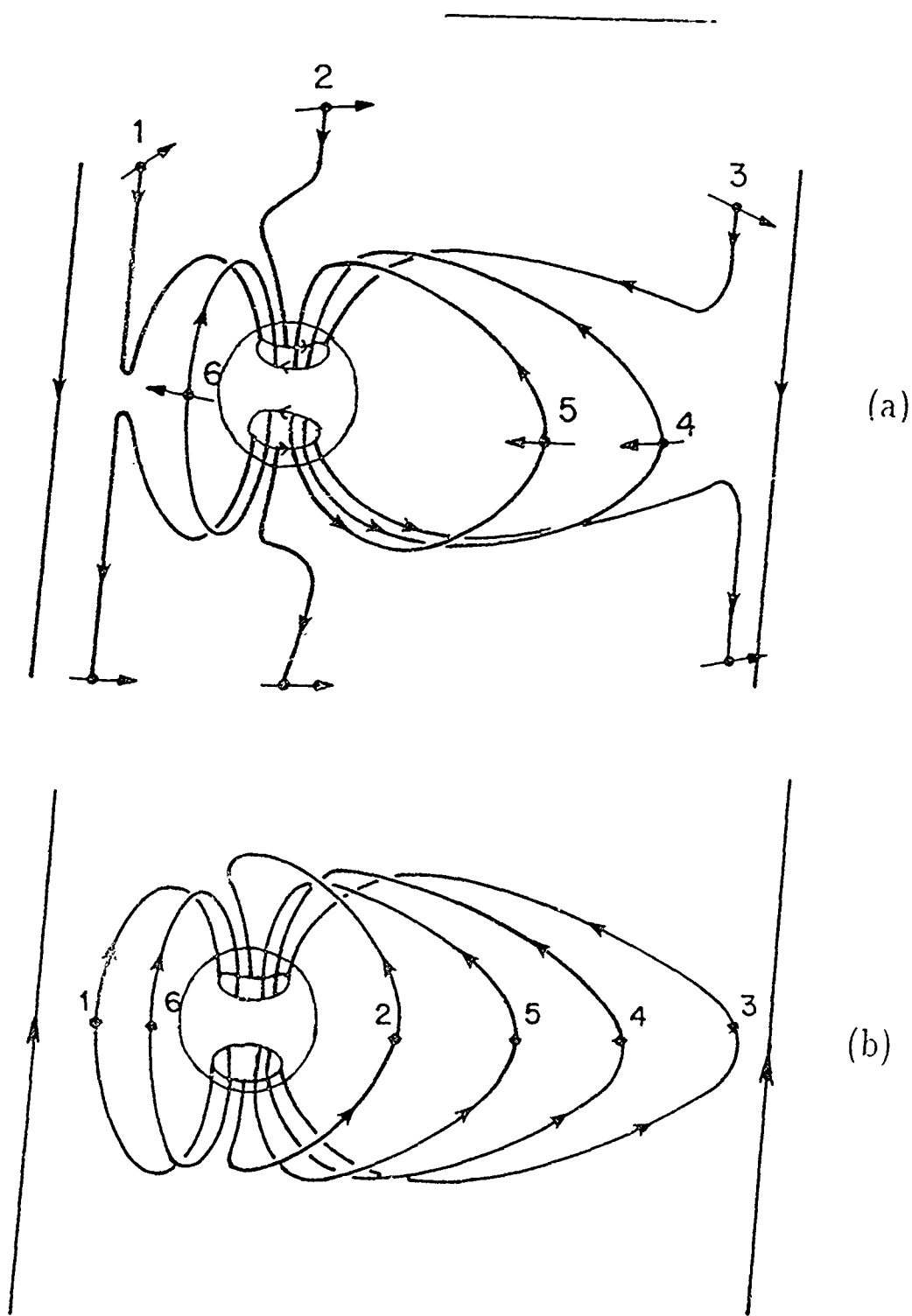

Figure 2. A schematic representation of the Earth's magnetic field and the IMF for the open (a) and closed (b) configuration. For the open magnetosphere note that the Earth's magnetic field lines 1, 2, and 3 are connected directly to the IMF and map to the polar regions of the Earth. This is the region of anti-sunward flow in the polar ionosphere, while the returning flow occurs at lower latitudes and on closed field lines 4, 5, and 6. For the closed magnetosphere there is little or no connection between the Earth's magnetic field lines and the IMF, so all the terrestrial field lines shown here are closed.

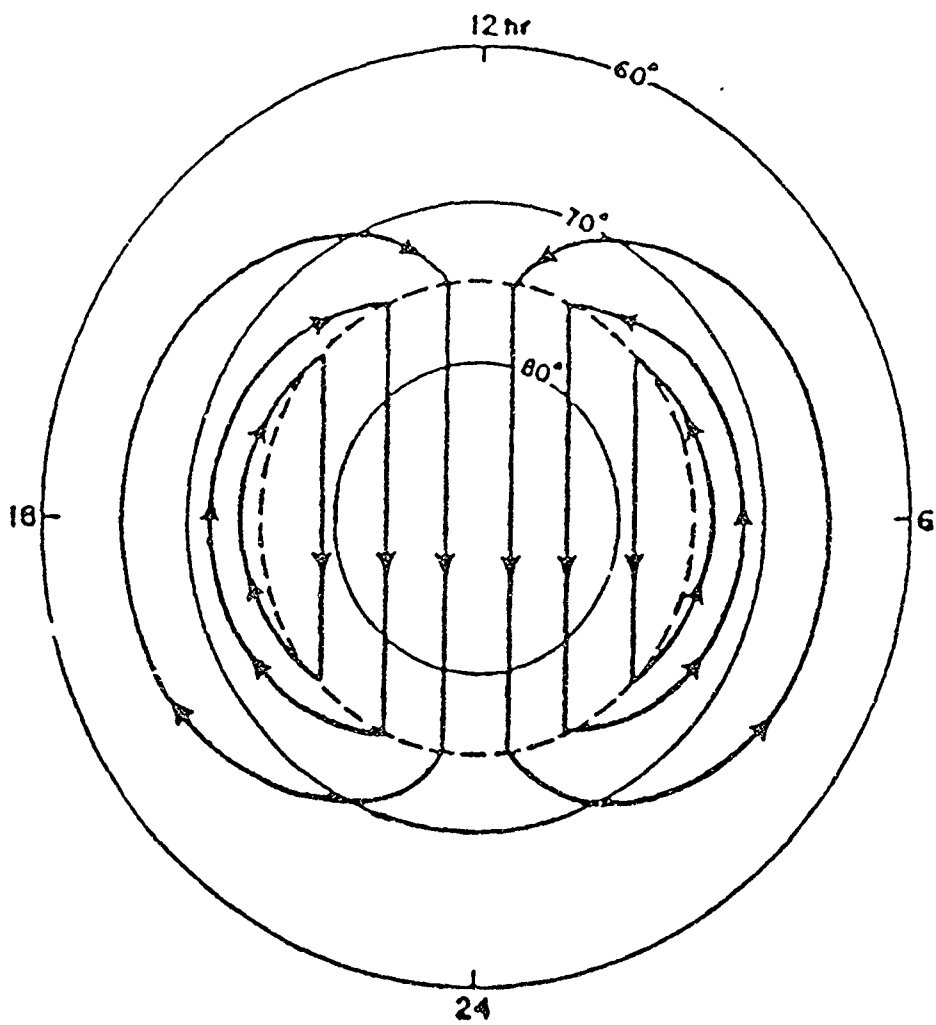

Figure 3. A simplistic schematic of the convection flow pattern in the polar ionosphere during times of IMF  $B_z < 0$  showing the anti sunward flow in the polar region and the returning flow at lower latitudes. The dotted line represents the convection reversal boundary. (From *Heelis et al.*, 1982)

of points where the plasma flow changes direction from approximately sunward to anti-sunward. The position of the flow direction change is referred to as the convection reversal boundary. This boundary also approximately maps the poleward limit of the auroral oval, the region where particle precipitation from the closed lines of the magnetosphere generates the auroral emissions in the lower ionosphere. The flow lines in the convection pattern describe the equipotentials of the electrostatic potential that is induced in the ionosphere by the solar wind flow. Thus the potential drop across the entire magnetosphere is mapped down to the ionosphere with the maximum and minimum potentials occurring at the dawn and dusk sides (respectively) of the convection reversal boundary. Polar orbiting satellites measuring either the high-latitude electric field or the high-latitude ion flows can be used to calculate this electrostatic potential distribution. Several empirical and mathematical models of the potential distribution/convection pattern have been constructed showing the dependence of the pattern on the orientation of the IMF (see *Heelis et al.*, 1982; *Sojka et al.*, 1986; *Heppner and Maynard*, 1987; *Hairston and Heelis*, 1990). While the overall geometry of the convection pattern during southward IMF is generally agreed upon, the geometry during northward IMF is still not understood (see *Heppner and Maynard*, 1987 for a discussion of this point) and is an ongoing research topic of this and several other research groups. A more complete discussion of the physical dynamics of the magnetosphere and ionosphere can be found in most introductory texts on space science (e.g., *Tascione*, 1988; *Hargreaves*, 1979).

The observed electrostatic potential can be used as an input to several of the models currently being developed. The program described in this report derives values for the potential maximum and minimum as well as several parameters characterizing the potential distribution pattern that will be used as inputs for the Magnetospheric Specification Model (MSM) developed by Rice University. These parameters can also be used in the Thermospheric General Circulation Model (TGCM) developed at the National Center for Atmospheric Research (NCAR).

### 3.0 INSTRUMENTS ON BOARD DMSP

DMSP F8 is in a circular, polar, sun synchronous orbit with equatorial crossings at 0600 and 1800 hours local time. The initial altitude is about 832 kilometers. DMSP F9 is in a similar orbit with equatorial crossings at 1030 and 2230 hours local time. The Special Sensor for Ions, Electrons, and Scintillation (SSIIES) on board both F8 and F9 consists of four instruments to study the ambient plasma: a planar ion retarding potential analyzer (RPA), a planar ion density trap (also known as the scintillation meter or SM), a spherical electron Langmuir probe (LP), and a planar ion drift meter (DM). A more complete description of all these instruments and their operations can be found in *Greenspan et al.* (1988). This report will focus on the drift meter (DM) data and its ability to provide the inputs referred to above. This report will also emphasize data from F8 since its orbit takes it much closer to the maximum and minimum potentials than F9.

An effort to model the magnetosphere and ionosphere during periods of southward IMF requires as some of its basic inputs measurements of the magnitudes and locations of the electrostatic potential maximum and minimum. It also requires some information about the distribution of the electrostatic potential in the ionosphere to determine the form of the ionospheric convection pattern. All of these inputs can be provided from analysis of the data taken by SSIIES on board the DMSP F8 and F9 satellites. The drift meter measures the bulk velocity of the thermal plasma in the two directions perpendicular to the spacecraft's velocity vector. Figure 4a shows the side view of a simple schematic of the drift meter. The opening of the DM faces into the direction of the spacecraft's motion so that the plasma enters the sensor. Connections to a quadrant collector can be arranged so that the current to two halves of the collector are measured. Any velocity of the ions perpendicular to the spacecraft's velocity vector results in an imbalance in the currents delivered to the two halves. By measuring that imbalance the angle of arrival ( $\alpha$ ) can be determined, and from that, the perpendicular velocity of the ions can be recovered. If  $V_p$  is the perpendicular velocity

of the ions and  $V_r$  is the ram velocity of the ions as they enter the sensor, then the perpendicular velocity can be calculated from the equation

$$V_p = V_r * \tan(\alpha). \quad (1)$$

As the perpendicular velocity of the thermal ions is on the order of 1-2 km/s and the spacecraft velocity is about 7.5 km/s this angle is relatively small. For the drift meter in a dawn-dusk orbit, the ion flow it encounters is predominately perpendicular to the spacecraft velocity vector, and so the ram velocity ( $V_r$ ) can be assumed to be equal in magnitude and opposite in sign to the spacecraft's velocity. The simple schematic of the DM seen face on in figure 4b shows the four current collectors arranged so that the sensor can measure the perpendicular flows in both the horizontal and vertical directions. The sensor returns six samples of the horizontal component and six samples of the vertical component of the perpendicular flow each second. (In the rest of this report, horizontal and vertical will imply the components of the perpendicular flow unless stated otherwise.) Using these two flows at any point along the spacecraft's track and the magnetic field data at that point, the electric field parallel to the spacecraft's velocity vector can be calculated by the magnetohydrodynamic (MHD) equation

$$E = -v \times B \quad (2)$$

where  $E$  = convection electric field (volts/meter),  $B$  = geomagnetic field (teslas), and  $v$  = ion drift velocity (meters/second). More specifically, the electric field along the velocity vector of the spacecraft is

$$E_{parallel} = (-v_{horz} * B_{vert}) + (-v_{vert} * B_{horz}). \quad (3)$$

By integrating the parallel electric field along the satellite track, a one-dimensional profile of electrostatic potential over the polar region can be obtained. Figure 5 shows a typical pass over the northern polar cap of DMSP F8 showing both the horizontal and vertical flows along with

## ION DRIFT METER SCHEMATIC

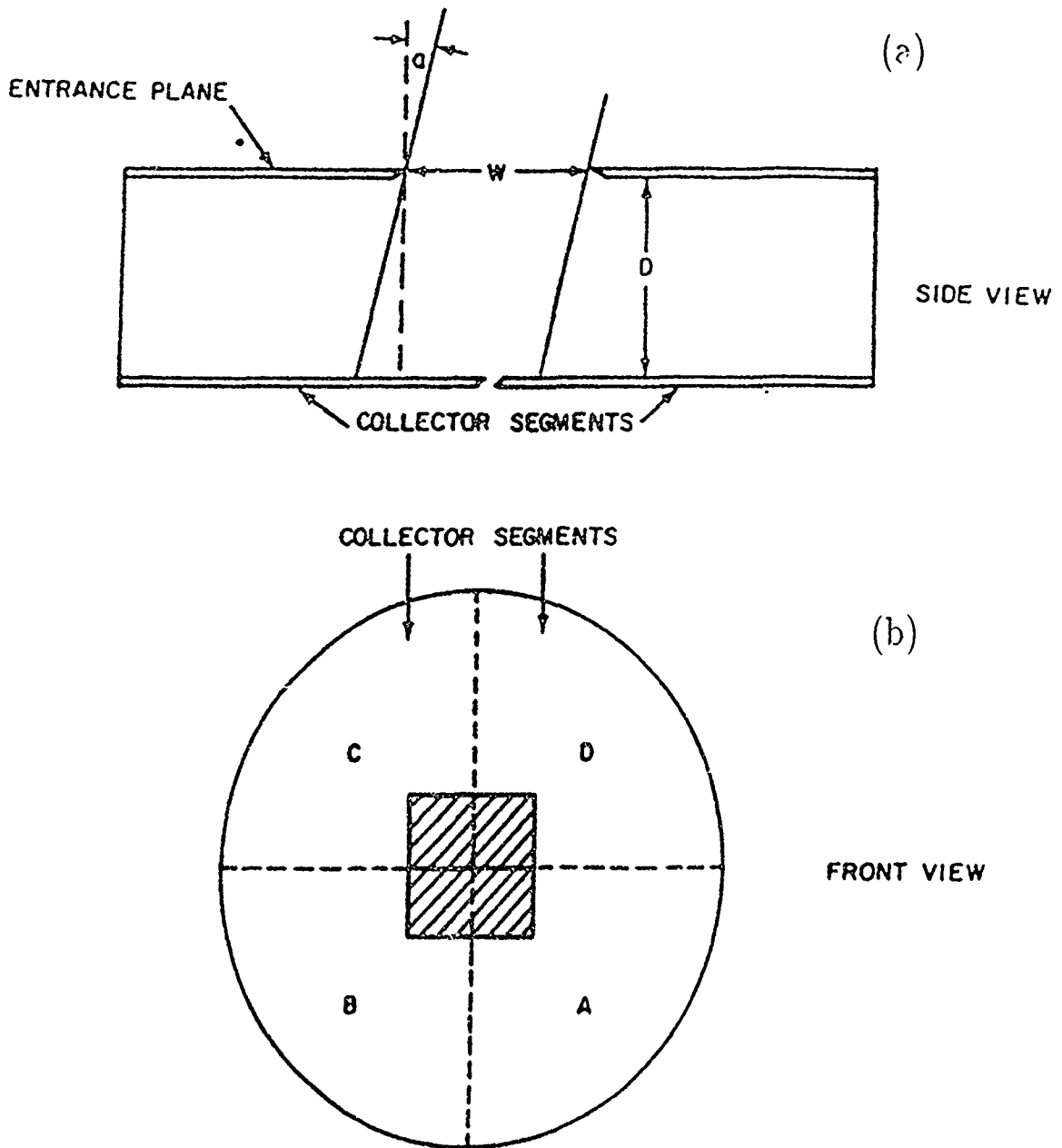

### IDM COLLECTOR / APERTURE CONFIGURATION

Figure 4. A simple diagram of the layout of the drift meter on board DMSP. A side view (a) shows how the ions enter the sensor through the aperture (marked by the arrows and the letter "w"). In this case a perpendicular flow to the left creates an imbalance in the current seen by the two collector segments, and this imbalance can be used to determine the perpendicular flow velocity. A front view (b) shows the configuration of the aperture (shaded in) and the four collector segments arranged so that the horizontal and vertical flow can be determined.

the calculated electrostatic potential curve. This pass occurred during a period of southward IMF and thus the potential curve exhibits the standard "sine wave" shape of the two-cell convection pattern. Since DMSP F8 is in a dawn-dusk orientation, the spacecraft generally flies through or near by the regions of maximum and minimum potential in the ionosphere, thus this calculation of the potential can be used to determine the potential drop across the polar cap needed by a magnetospheric model.

The SSIES data is combined with geophysical data and stored onto computer tapes. Each tape contains ten days worth of data which is formatted in a manner similar to the "PREPFILE" format used by AFGWC. See *Delorey et al.* (1989) for a complete description of the tape format. The format here is as follows. Each minute begins with the ephemeris data (hereafter called the OA header) which gives the following data at the first second of that minute: year, julian day of year, hour, minute, second, geographic latitude, geographic longitude, geographic latitude at the subsolar point, geographic longitude at the subsolar point, geomagnetic latitude at satellite, geomagnetic longitude at satellite, geomagnetic latitude at 110 km, geomagnetic longitude at 110 km, geographic latitude at 110 km, geographic longitude at 110 km, invariant latitude, altitude (in nautical miles) at the beginning and ending of the ephemeris minute, the  $x$ - $y$ - $z$  coordinates of the satellite in the Earth-centered inertial (ECI) frame of reference, and the magnetic field components at the location of the spacecraft. DMSP F8 does not carry a magnetometer on board and so the field at the spacecraft is calculated using the IGRF80 model before 1 March 1988 and the IGRF85 model afterwards. The magnetic field is given in coordinates of  $B_{north}$ ,  $B_{east}$ , and  $B_{downward}$ . The OA header is followed by 60 blocks of data, each block containing 120 words. Each block of data corresponds to one second of data from SSIES. Words 6, 26, 46, 66, 86, and 106 of a one-second block are (sequentially) the raw vertical flow data for that one second. Likewise, words 16, 36, 56, 76, 96, and 116 are (sequentially) the raw horizontal flow data for that one second. At the end of

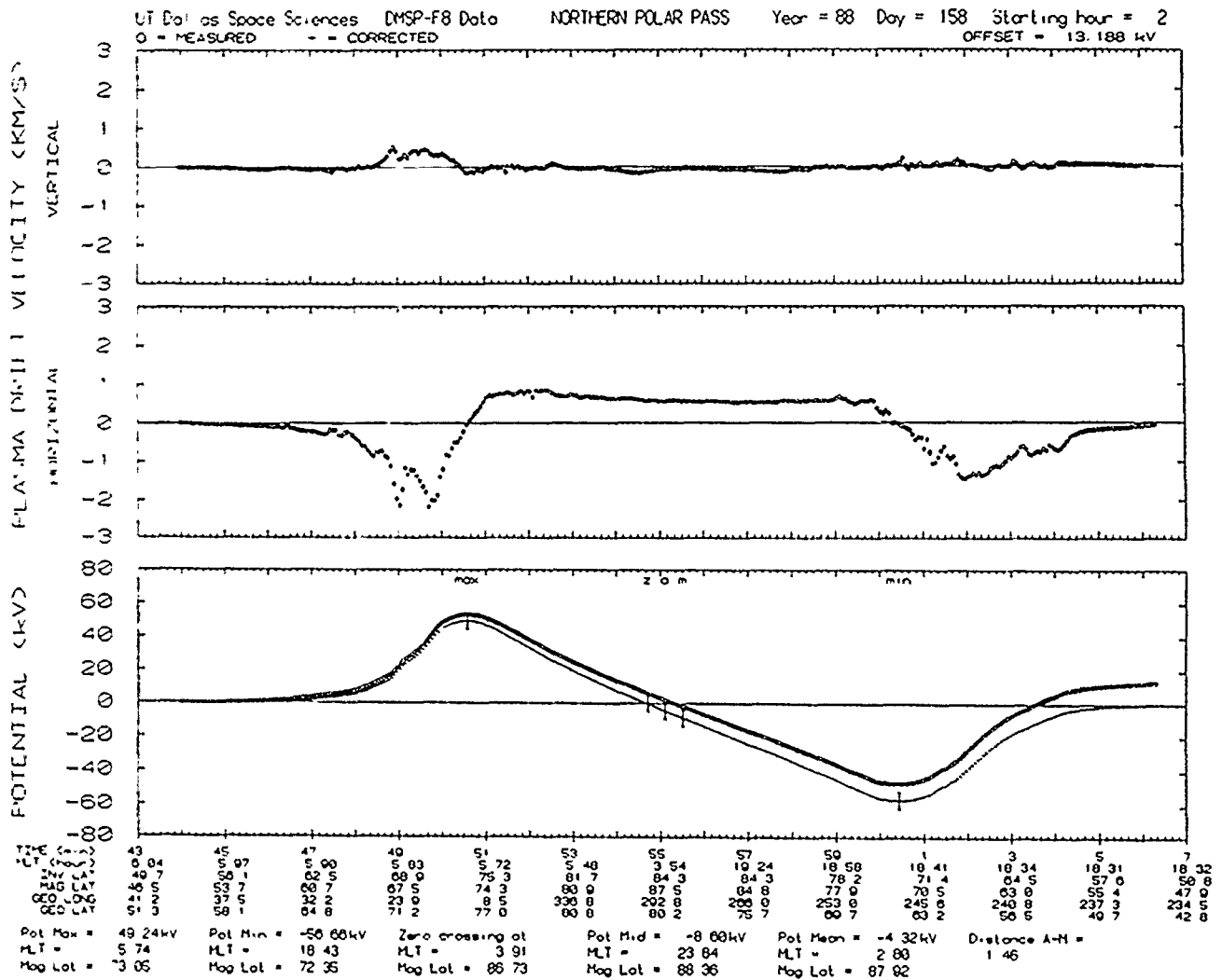

Figure 5. A typical northern polar pass of DMSP F8 taken on June 6, 1988. The top frame shows the vertical flow data, the middle frame shows the horizontal flow data, and the bottom frame shows the corresponding potential curve calculated from the flow data. Note that the heavy line in the potential frame is the initial potential curve and the light line is the potential curve after being corrected to force both ends to zero potential.

the 60 blocks of data comes the OA header for the next minute, followed by the next 60 blocks of data, and so forth through the entire ten days of data.

During the past three years we have developed several programs for the analysis of the drift meter data and used that data in a variety of research pursuits. Data from both DMSP F8 and F9 are being used to improve ionospheric convection pattern models (*Harrston and Heelis, 1989*). Data from this period are currently being used in conjunction with two of the high-latitude plasma structure (HLPS) studies being coordinated by Dr. Sunanda Basu. A fully automatic program which reads a complete tape of ten days of data to analyze the drift meter data in the polar regions and calculate the parameters described above was written during this period. This program, DMSP Potential Model 2 (DMSPPOTMOD2.FOR), was delivered to the Geophysics Laboratory at the end of 1989 and this technical report is intended to serve as the user's manual for that program.

#### 4.0 DETAILED DESCRIPTION OF THE PROGRAM

DMSPPOTMOD2.FOR was designed so that the user could take a single DMSP tape containing ten days' worth of data (and later a disk file at AFGWC containing one day's worth of data) then have the program read and process all the polar passes in a single run. This program was developed on a Digital Equipment Corporation VAX computer using the VMS operation system and VMS FORTRAN. The program is broken into four main blocks that are organized as follows: block 1 reads the data from a pass, loads the data into arrays, and then corrects the flow data for the ionospheric corotation velocity. Block 2 finds the zero flow baseline of the flow data and then performs the integration of the electric field to derive the electrostatic potential along the satellite track across the polar cap. Block 3 uses the previous analysis to determine several geophysical and ionospheric parameters (magnitude and location of potential maximum, magnitude and location of potential minimum, etc.). Block 4 loads these parameters into a datafile. The

program then loops back to block 1 and begins searching for the next polar pass and repeats the process. This cycle continues until the end of the tape is reached. To fully describe the operations of DMSPPOTMOD2.FOR an example of the analysis of a single pass is presented below:

#### 4.1 BLOCK 1: DATA INPUT

Block 1a: (*Starting point*) This portion of the program is only used at the beginning of a run. The program asks the user for a starting time (in the form of YY,DDD,HH,MM) and converts the response into the numerical form necessary for the DMSPRD tape reading routine. If the user wants the program to start at the very beginning of a tape (or data file) regardless of the actual times, then the user enters 0, 0, 0, 0 for the starting time. This is the only time the program requires interaction from the user, everything else is automatic.

Block 1b: (*Search for start of pass on the tape*) Here the program begins at the designated starting time and begins searching for the first minute where the satellite crosses a given magnetic latitude (SMAGLIMIT) heading poleward. The value for SMAGLIMIT sets both the starting and stopping point for the data reading. It is set at 18 degrees, thus causing the program to read and save all the flow data poleward of 18 degrees magnetic latitude. Once the program finds the crossing point it branches to the next block.

This block begins the search for the starting point of each polar crossing analysis throughout the entire run of the program. In order to properly analyze a polar crossing, the data must be complete during the crossing from the equatorial edge of the auroral region, over the polar region, and back to the equatorial edge of the auroral region. Occasionally, gaps of one minute will turn up in the data. However, as long as the gap is no longer than one minute and there is no more than one such gap in the crossing, then the algorithm can tolerate it with little harm to the quality of the output. More often gaps ranging from tens of minutes to hours will appear in the data. Due to the existence of these longer data gaps and the fact that the starting point on any individual

tape can be anywhere in an orbit, several checks to determine where to begin taking the data are made. Four possible cases and the actions taken are listed below:

- \* search starts at any point equatorward of SMAGLIMIT, (this is the nominal case). then program searches forward until it reaches the next SMAGLIMIT crossing, then branches to the next block and begins taking data.
- \* search starts at a point poleward of SMAGLIMIT but less than 50 degrees magnetic latitude and the satellite is heading poleward, then the program branches to the next block and begins taking data because there is probably enough data to complete a full polar pass analysis.
- \* search starts at a point poleward of SMAGLIMIT but less than 50 degrees magnetic latitude and the satellite is heading equatorward, (the satellite has already passed a full polar crossing) then the program then starts searching for the next SMAGLIMIT crossing in the other hemisphere, then branches to the next block and begins taking data.
- \* search begins at any point poleward of 50 degrees magnetic latitude, (there will not be enough data in this polar crossing for a reasonable analysis) then the program begins searching for the SMAGLIMIT crossing in the next hemisphere, then branches to the next block and begins taking data.

There are a few other checks placed in the block. After the first time data is read from the tape by calling the subroutine DMSPRD, the satellite identification (F8, F9, etc.) is read and assigned to the variable ISATNUM. Every subsequent invocation of DMSPRD throughout the program is followed by two checks. The first checks the returned variable ISATID which is equal to -1 as an end of tape flag. If such a flag is seen, then the routine branches to the end and the program stops. A second check ensures the day of year is less than or equal to 366. A higher value (usually 999)

for this variable indicates a minute of fill data on the tape, thus the program skips ahead and reads the next minute on the tape.

Finally, as the program searches through the data, it keeps a running record of the previous two minutes for reasons that are explained in the next section.

Block 1c: (*Data reading*) Here the program reads the data for the polar pass from the tape and stores it into arrays for later use. The program branches to this block just after it has found the minute after the spacecraft has crossed the SMAGLIMIT latitude. For completeness the program should now back up one minute on the tape before beginning the data reading. However, in order to interpolate the geophysical parameters and perform the corotation correction later in the program, it is necessary to have the OA header data from the minute preceding the first minute of the polar pass data and the OA header data from the minute following last minute of the polar pass. These two minutes of data will be referred to as the "bracket minutes". Thus the program needs to back up two minutes from its current location before it begins reading the data and writing it into the arrays.

This new starting time is calculated by subtracting 120 seconds from the "current" time as read in the last OA header. Before the program reads data from this new starting time, a check is made. There are a small but finite number of cases where the SMAGLIMIT crossing occurs just at a data gap, thus the data from two minutes prior to this may not exist on the tape. However, without a check against this, the program will search forever for this "missing minute". In block 1b the time values of the previous two minutes of data have been saved so that the new starting time can be checked against them. If they match, then there are no data gaps and the program continues. If they do not match, then a gap exists and the program branches back to block 1b and resumes the search for a suitable starting point. Assuming there was no gap, the OA header data from the beginning bracket minute is read and the  $x$ ,  $y$ , and  $z$  coordinates of the satellite in

the ECI system are saved as the dummy variables FCX, FCY, FCZ. A beginning time in seconds (BGNGTIM) is defined and several counters are set up.

At this point the program begins calling the subroutine IDMREAD to read the data from the polar pass. IDMREAD cycles through each minute of the data reading the data from the OA header and saving the geophysical parameters (magnetic local time, magnetic latitude, invariant latitude, magnetic field components, satellite altitude, and the final geographic latitude) along with the ion flow data and corresponding times. The subroutine also uses the current and previous positions of the satellite in the ECI system to calculate a running correction that will be used later in the corotation correction subroutine. (A more detailed explanation is given in appendix A.) The subroutine continues reading the data and loading it into the arrays until the satellite recrosses the SMAGLIMIT latitude heading equatorward, then it returns to the main program in block 1c.

After the OA header for each minute is read, the program goes through the sixty telemetry blocks containing the flow data for each of the sixty seconds during that minute. As the flow data are read in IDMREAD an initial smoothing operation is performed on them. On board the spacecraft the drift meter cycles between measuring the horizontal and vertical ion flows six times per second thus producing the six horizontal and six vertical telemetry values per second. For the purposes of this program a resolution of one data point every four seconds is all that is necessary. Thus the program averages the each flow component over four sequential blocks, resulting in the average of 24 telemetry data points saved as a data point in the arrays FLOWH and FLOWV (for FLOW Horizontal and FLOW Vertical). While a statistical analysis of this averaging is possible and may be done in future versions, it is not needed at this point.

A simple averaging of the 24 sequential points is the most common operation at this point, however, the program is sophisticated enough to weed out fill data and bad data taken during times when the Langmuir probe is operating. A series of checks are inserted in the program to

screen for these. The first word in each datablock of one second of data identifies the mode and/or cycle counter of the instruments. If the first word is 00000010 (telemetry value of 2) or 00000100 (telemetry value of 4) then that indicates the Langmuir probe is active during that second and the flow data for that second are unusable. If the first word is 00101101 (telemetry value of 45) and the first word of the next datablock is either 2, 4, or greater than 59, then the current second of data also occurs during a Langmuir pulse and the data are unusable. If the first word in the datablock is 11111111 (telemetry value of 511) then that second contains only fill data. In all these cases the program skips that datablock and continues on to the next second of data. A running count of the number of data points read (DIVIDE) is kept during the readings in order to average the data correctly. If the program reaches the end of a four second block with DIVIDE still equal to zero, then a fill value of 999 is written to that element of the FLOWH and FLOWV arrays. Once the averaging of the telemetry is accomplished the data is converted from a telemetry value to its corresponding velocity value (in kilometers/second) then stored in the FLOWH and FLOWV arrays. The corresponding time (in seconds) is then saved in the array XUTIME. XUTIME uses the same index (ICYCLE) as the FLOWH and FLOWV arrays so that there is a one to one correspondence between the array elements. This checking procedure would not be necessary if the data came from a pre-processed file--such as the astrogeophysical data base (AGDB) at AFGWC.

When the program sees the spacecraft cross the SMAGLIMIT latitude heading equator, and it branches to the end of the IDMREAD and reads the OA header of the next minute. Values for various geophysical parameters (magnetic latitude, invariant latitude, magnetic field components, etc.) are saved in the appropriate arrays for use in later interpolations in the corotation correction subroutine. The IDMREAD subroutine then ends and the program returns to block 1c.

There are two checks within the IDMREAD subroutine. The first checks for the end of tape flag in ISATID after each call to DMSPRD. If the end of tape is detected during IDMREAD, the program returns to the main program and then branches to the end and quits without any further analysis of this pass. The other check makes sure that there are no missing minutes of data during the IDMREAD. If any gaps are detected the variable IMISS is set to 1 and the IDMREAD subroutine continues to the end of the pass so that the program has a starting time to use for the next pass. If IMISS is 1 when the program returns from the subroutine then that pass is unusable, so the program creates a null data file for that pass, then branches back to block 1b to start the next pass. The null datafile is identical in format to all the other datafiles for each pass except that it contains only the time of the pass and has values of zero for all the other elements. This marks the end of block 1 of the program.

#### 4.2 SUBROUTINE COROTFIX

Assuming that the pass was completed with no data gaps, then the program continues on to the next section which is the subroutine COROTFIX. This section removes the contribution to the flow values from the corotation of the earth's atmosphere and interpolates the geophysical parameters in four-second steps. A short description is presented here of the algorithm used in this subroutine to correct for the corotation. (A more complete explanation is given in appendix A.)

In order to properly calculate the electrostatic field in the ionosphere using the flow data, it is necessary to measure the ion flow in a nonrotating frame fixed relative to the sun-Earth line. However, since the earth turns in space, some of the ion flow observed by the spacecraft comes from the corotation of the ionosphere so that component must be removed from the data. This corotation is always perpendicular to the spacecraft vertical axis and thus affects only the horizontal-cross-track and horizontal-parallel-track components of the flow. Since the horizontal-parallel-track component is not considered in this program, it is only necessary to calculate the correction for the

horizontal cross-track component. The magnitude of this corotation varies with latitude, ranging from an absolute maximum at the equator to zero at the geographic poles. This correction is further complicated by the fact the spacecraft is moving at some angle relative to the corotation flow vector and this angle is continually changing throughout the orbit. In the IDMREAD routine the instantaneous correction factor was calculated at the beginning of every minute during the pass. However, it is now necessary to apply those corrections for flow data that occur every four seconds. The subroutine does a linear interpolation between the correction factors at the beginning of the previous minute and the next minute, then corrects the horizontal flow data within the current minute. The corrected horizontal flow data is then replaced into the FLOWH array. Because of this interpolation, the corrections cannot be applied until after all the data from a single pass has been read. This interpolation is also the reason why the OA header data from the "bracket minutes" on either end of the pass must be read and saved. The subroutine tallies the number of elements in the flow array during the correction and at the end saves the total value in the variable ICYCMAX.

For later calculations in the program it is necessary to have values for several OA header parameters every four seconds to correspond to the flow values. Since these parameters are only given at the beginning of each minute of data the program must now interpolate values for the intermediate times. The program takes the values saved in the various geophysical arrays from block 1c, reads in the values for two subsequent minutes, then performs a linear interpolation for ever four seconds on each of the parameters and loads them into new arrays. The data in the arrays are indexed to correspond to the index of the flow arrays (FLOWH and FLOWV) and time array (XUTIME). The OA header parameters and their arrays are given below:

OA HEADER PARAMETER	ONE-MINUTE ARRAYS	FOUR-SECOND ARRAYS
magnetic field north component	BN	CALBN

magnetic field east component	BE	CALBE
magnetic field downward component	BD	CALBD
spacecraft magnetic local time	SCMLTM	SCCHMLTM
spacecraft geographic latitude	SCLAT	SCCHLAT
spacecraft magnetic latitude	SCMLAT	SCCHMLAT
spacecraft invariant latitude	SCINVLAT	SCCHINVLAT

In the interpolation procedure the values for the magnetic field components are converted from units of nano-teslas (as they are given in the OA header) into units of teslas (as they will be needed for later calculations). The subroutine also includes a check to see if the spacecraft crossed the midnight line between the two minutes. If this occurs, the program branches to a special algorithm that takes this into account when interpolating the position parameters. Finally, the subroutine uses the altitude data to calculate the path length of the satellite in four-second increments and loads that data into the array PATHLEN. The subroutine is now finished and returns to the main program.

#### 4.3 BLOCK 2: CALCULATION OF THE ELECTROSTATIC POTENTIAL

Block 2a: (*Boundary determination and zeroing of the baseline*) At this point the data are now suitably arranged into arrays for analysis. First the program must determine the outer boundaries of the auroral region and zero the baselines of the flow data. Far outside the polar region, the geophysical horizontal and vertical ion flows in the corotating reference frame are extremely small. However, the observed data from DMSP F8 and F9 may not yield nearly zero flow because the baseline of both components of flow can change with time. No systematic variation of this instrument baseline has yet been found, thus it is believed to be caused by spacecraft charging or compositional effect. Whatever the cause, it can be corrected and compensated for by rezeroing the baseline for each individual pass. To rezero the pass correctly the program must also determine

the extent of the auroral region. For almost all passes a starting and stopping point of 50 degrees magnetic latitude is sufficient to place the spacecraft outside of the auroral region. However, in cases of a magnetic storm (such as the storm of March 14, 1989), the auroral region expands equatorward and can reach 30 degrees magnetic latitude or further. It is for this reason that the initial reading of the data starts and ends at 18 degrees magnetic latitude, to ensure that all the necessary data is available for analysis.

The program first starts at 50 degrees magnetic latitude, sampling five four-second averaged points from either end of both the vertical and horizontal flows. Each group of five is averaged, then the variances of the two horizontal flow groups are calculated, and finally the differences between the averages of either end of the horizontal and vertical flows are calculated. If the differences between the ends of both flows are both less than 0.7 km/s and the variances of both ends of the horizontal flow are less than 0.002 then the starting and stopping points are judged to be outside of the auroral region. (These cutoff values were determined to be satisfactory during the development of the program, but can be easily changed later if the need arises.) The examination of the variance checks to make sure the data at the ends are fairly constant, as opposed to the rapid change in values of the data inside the auroral region. The examination of the differences of the averages of the ends is to make sure that the baselines on either end of the pass are close enough to one another to make a rezeroing of the flow data worthwhile. If the pass fails any of these checks, it is assumed that the auroral region has expanded equatorward. The program repeats the examination procedure starting at 45 degrees magnetic latitude on either end of the pass and continues looking further equatorward in five degree increments until suitable starting and stopping points are found. If the program reaches 20 degrees magnetic latitude without satisfying the checks, then that pass is ruled unusable. The program generates a "null file" (saving only the

time of the pass with zero values for all the other data) for the database covering this pass. After recording the "null file" the program returns to block 1b and begins working on the next pass.

In better than 99% of all cases, however, a suitable boundary to the auroral region is found. Now a rezeroing of the ends is performed by taking the average of the two averages from the ends of each flow and removing this value from each data element in the appropriate array. This results in both flow curves for this pass being shifted up or down so that their ends are now zero or else symmetric about the zero line. The starting and stopping magnetic latitude are saved for use in the next block.

Block 2b: (*Potential calculations*) At last the ion flow data and the magnetic field data are in the form necessary to calculate the electrostatic potential along the satellite's track as it crosses the polar region. The program scans through the SCCHMLAT array until it reaches the starting magnetic latitude. It then uses the index (ICYCLE) from that element to set the starting point for the data in the flow and magnetic data arrays. The electrostatic potential far equatorward of the auroral region is defined as zero, so the first element of the potential array (POT) is set to zero. The electrical field in the ionosphere is given by the MHD equation (2). Thus for the electric field in the direction of the spacecraft's trajectory is calculated by equation (3). The flow data are already in the proper coordinate system as is the vertical component of the magnetic field. The horizontal component of the magnetic field must be calculated from the northward and eastward components of the magnetic field. Once this conversion is performed, the electric field parallel to the spacecraft's trajectory is calculated and then multiplied by the path length between this point in the array and the next to determine the change in potential between the two points (DPOTENT). (The path length was the value saved as an element in the array PATHLEN in subroutine COROTFIX.) This change in the potential is added to the running total of the potential (POTENT). The current value of the running total of the potential is then saved as the value of

the next element of potential array (POT). The program then iterates to the next element of the flow and magnetic data arrays and repeats the process. Thus, as the program goes through the data, the potential at any element ICYCLE is the sum of all the potential changes using all the flow and magnetic data through the ICYCLE-1 elements.

This procedure repeats until the pass is completed and the satellite crosses the stopping magnetic latitude. If a flow value of 999 (fill data) is encountered during the run, the program reuses the previous change in potential to add to the running total potential. The values of the beginning and ending indices of the flow and magnetic data arrays are saved as ICYCBEGN and ICYCEND for later use, along with TOTNUMB, the total number of nonzero elements in the POT array.

Block 2c: (*Offset correction*) In an ideal polar pass both ends of the electrostatic potential curve are zero, so the running total potential at the end of block 2b should be zero. In reality, this is rarely the case. Since the polar crossing takes at least twenty minutes to complete there is probably some change in the overall convection pattern during this time, which results in the running total potential ending with a nonzero value. The value is referred to as the "offset" of the potential of this pass. The program now does a linear correction to the the elements in the array POT so that the end of the potential curve is forced to be zero. The corrected values of the potential curve are saved to the array POTFIX.

When the offset of the potential is large (say over 25% of the total potential drop), there is no way of determining whether the offset of that single pass was caused by a change in the convection pattern during the pass or whether it was caused by a dc-offset in the flow data. The current version of the program makes no attempt to categorize the quality of the passes based on the potential offset. However, it should be noted that the values and locations of the potential maximum and minimum in the corrected potential array are relatively insensitive to changes in the magnitude of the offset. Several passes were analyzed by varying the dc-offset of the horizontal and vertical flow

data in order to increase or decrease the offset in the potential curve. The potential curve was then corrected to force the potential to zero at both ends and the resulting maximum and minimum were calculated. As the potential offset was varied from +100 kV and -100 kV the corrected maximum and minimum values varied by less than 2%. Thus, even for passes with high potential offsets, there is a fairly high confidence in the quality of the corrected potential parameters.

#### 4.4 BLOCK 3: ANALYSIS OF THE ELECTROSTATIC POTENTIAL

Block 3a: (*Search for maximum and minimum*) Now the program takes the corrected potential array data and uses it to determine several ionospheric parameters required for the database. Here the program sequentially searches the array POTFIX to find the absolute maximum and minimum values of the potential. These values are saved as the variables PSIMAX and PSIMIN. The corresponding elements of time, magnetic latitude, magnetic local time, and invariant latitude for both the potential maximum and minimum are also saved as the variables UTMAX(-MIN), SCMLATMAX(-MIN), SCMLTMAX(-MIN), and SCINVLATMAX(-MIN). It also saves the indices for the maximum and minimum elements as ICSTRT and ICSTP for later use. (Note: If the spacecraft is in the southern hemisphere, then the values for SCINVLATMAX and SCINVLATMIN are negative. This is contrary to the convention where invariant latitude is always positive, but it serves here as an easy way of distinguishing hemispheres in the datafiles without adding another element to those files. The values of magnetic latitude change sign with the change in hemisphere, but they are not required for this database so are ultimately not saved in the datafile.)

Blocks 3b, 3c, 3d: (*Search for zero point, midpoint, and mean point*) In these three blocks the program searches for the location in the POTFIX array for the points between the maximum and minimum potential points where the spacecraft crosses the zero potential, where the spacecraft is midway between the two, and where the potential is equal to the mean of the maximum and minimum potential. These values can be used later to characterize the distribution asymmetry of

the potential and the overall shape of the convection pattern. For the zero point search, the program starts with the whichever potential extreme comes first (POTFIX(ICSTRT)) then goes through the array until a sign change is detected. At the sign change the corresponding time, magnetic local time, and magnetic latitude are saved as the variables UTZERO, ZEROMLT, and ZEROMLAT. It also saves the index of the zero crossing point as IZEROCNT for later use. If the IMF is southward and stable during the pass then only one zero between the maximum and minimum potential points should be expected. For northward IMF or other pathological cases, there may be multiple zero crossing points between the maximum and minimum potential points. In such cases the program saves only the first zero crossing, but this limitation does not yet affect the Rice University Magnetospheric Specification Model (MSM) as it only uses the DMSP data during times when a definite two-cell convection pattern is observed. The midpoint between the maximum and minimum potential points is found from the element in the array POTFIX that occurs halfway in time between the two extrema. This is an accurate procedure since the satellite is in a near-circular orbit and thus maintains a nearly constant speed as it makes a polar crossing. The program saves the corresponding elements from the corrected potential, time, magnetic latitude, and magnetic local time as the variables PLMIDPOT, PLMIDUT, PLMIDMLAT, and PLMIDMLT. To find the mean point, the program takes the mean of the maximum and minimum potentials, then, beginning at whichever extreme occurs first (POTFIX(ICSTRT)), searches sequentially through the array until it passes that mean value. That element of POTFIX is then saved as the variable POTMEAN while the corresponding time, magnetic latitude, and magnetic local time as saved as the variables POTMEANUT, POTMEANMLAT, and POTMEANMLT.

Block 3e: (*Distance between midpoint and mean point*) Once the locations of the midpoint and the mean point are determined, the distance between them is calculated in polar coordinates. This

value can be used later to quantify the asymmetry of the potential curve and relate that to the overall shape of the ionospheric convection pattern.

Block 3f: (*Potential correction*) In an ideal polar pass the satellite would cross along the 0600-1800 MLT line and go directly over the magnetic pole. However, since the satellite tracks the dawn-dusk terminator and the Earth's magnetic dipole is tilted, the net result is that the satellite's track wanders back and forth across the polar region when viewed in magnetic latitude-MLT coordinates (figure 6). Thus the measured potential drop is usually less than the true total potential drop. In fact, the southern magnetic pole is tipped so far from the satellite's orbital inclination that the satellite misses the auroral region altogether for about 15-20% of the orbits. Since any magnetospheric model would require the total potential drop as one of its inputs, it is necessary to extrapolate the true potential drop from the measured potential drop. Eventually it is planned to have enough data to develop a sophisticated correction algorithm, but for the present the program uses a simple "rule of thumb" based on calculations from the Heppner-Maynard ionospheric potential models. The program goes through the magnetic latitude array (RGMGLT) and searches for the highest magnetic latitude that the satellite reached, then uses that to determine a correction factor for the measured potential to obtain the true total potential. The correction factor is saved as the variable PSICORFAC. (RGMGLT, the array of magnetic latitudes every minute, is used here instead of SCCHMLAT because it has few elements to check and since SCCHMLAT is derived from RGMGLT there is no element in SCCHMLAT that would be greater in value than the maximum value in RGMGLT.) If the satellite reaches a magnetic latitude of 85 degrees or higher on its pass, then the measured potential drop is assumed to be equal to the true total potential drop and PSICORFAC is set equal to 1.000. If the highest point on the satellite's track is between 80 and 85 degrees, then the correction factor is set to 1.085. If the highest point on the satellite's track is between 75 and 80 degrees, then the correction factor is set to 1.215. If the highest point is

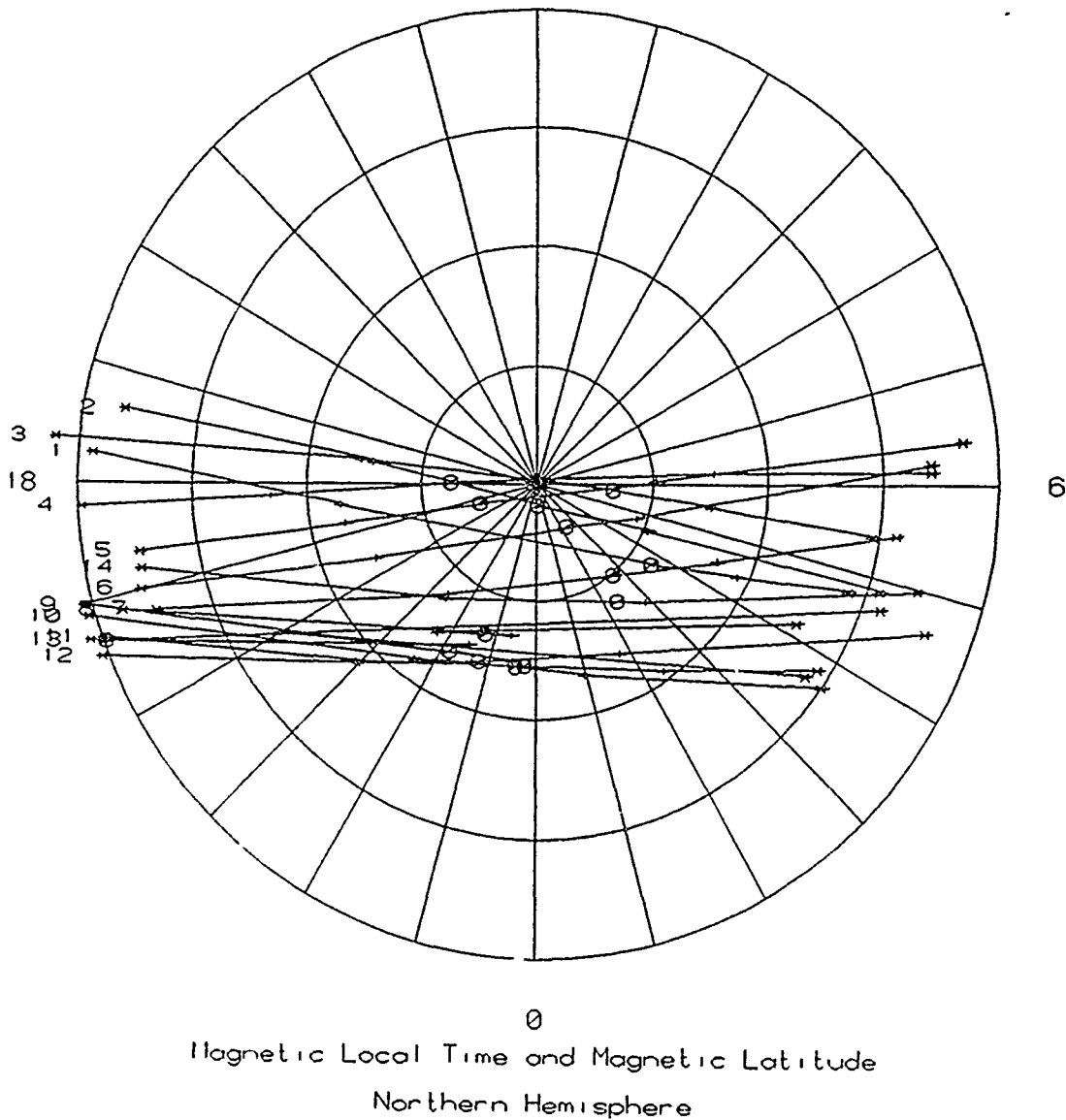
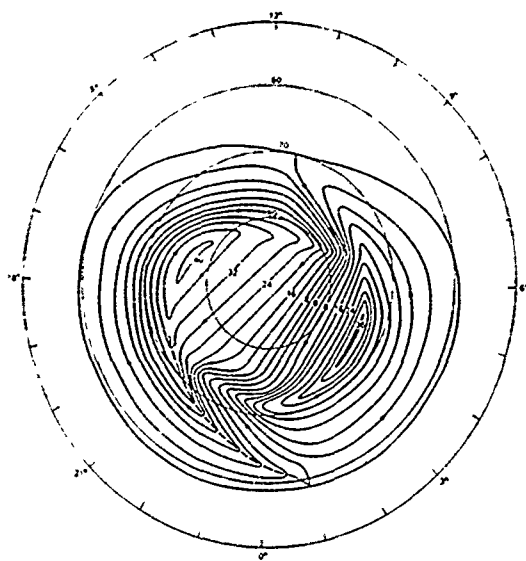

Figure 6. A polar plot of the northern high-latitude region in magnetic latitude and magnetic local time coordinates showing all the passes of DMSP F8 for February 12, 1988. Because of the tilt of the Earth's dipole magnetic field relative to the Earth's spin axis and the orbital plane of the satellite, the orbital track in the magnetic latitude-MLT coordinates moves sunward and anti-sunward relative to the 0600-1800 MLT line over the course of a day. This allows the satellite to sample the plasma environment at a fairly wide range of locations in the high-latitude ionosphere.

less than 75 degrees, then it cannot be assumed that the satellite crossed enough of the convection pattern to get a meaningful measurement. In those cases the correction factor is set to 0.0 as a flag meaning this pass should be disregarded.

Block 3g: (*Heppner-Maynard model classification*) Another input which is helpful to a magnetospheric model is a designation of one of the three Heppner-Maynard convection models for southward IMF that best matches the data (*Heppner and Maynard, 1987*). This is determined by measuring the asymmetry in the distribution of the potential along the satellite track. As can be seen in figure 7 the zero potential line is just slightly downward of the noon-midnight line in the Heppner-Maynard model DE, while the model BC shows the zero potential line to be pushed very far duskward of the noon-midnight line relative to the convection reversal boundary. Model A represents the intermediate case between the two. The program chooses which model best fits by calculating the distance from the maximum potential point and the zero crossing point and dividing that by the distance from the maximum to the minimum potential point. If the ratio of the two distances is greater than 0.5865 then model DE is chosen and the program sets IMODNUM equal to 3. If the ratio is less than 0.3341 then model BC is chosen and the program sets IMODNUM equal to 1. This leaves only those cases where the ratio is between 0.3341 and 0.5865 which means model A is chosen and IMODNUM is set to 2. The cutoffs for this algorithm were determined by directly measuring the asymmetry of the Heppner Maynard models. These cutoffs can, of course, be changed or modified in the future if the need arises.

Before the program chooses a model, it checks for northward or southward IMF. While the satellite does not have any direct way of measuring the IMF, the shape and magnitude of the electrostatic potential curve can be used to infer information about the condition of the IMF. For cases of southward IMF the potential distribution along a dawn-dusk cut forms a rough sine curve with a potential drop of 40 kV or more. For cases of northward IMF the electrostatic curve is more



model BC

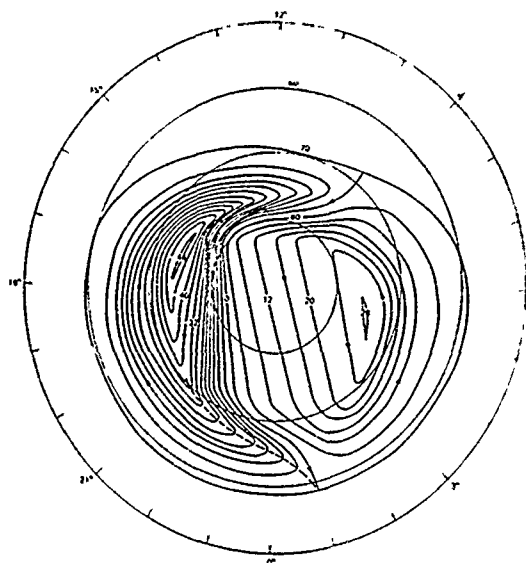

model DE

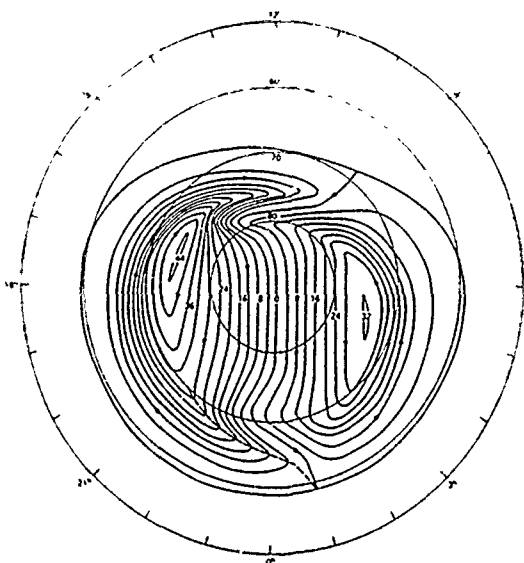

model A

Figure 7. The three high latitude ionospheric convection pattern models during southward IMF periods from *Heppner and Maynard (1987)*. Model BC is the pattern in the northern hemisphere during periods when  $B_y > 0$ . Model DE is the pattern in the northern hemisphere during periods when  $B_y < 0$ . Model A is the intermediate pattern which occurs during periods when  $B_y > 0$ .

irregular with multiple zero potential crossings and a total potential drop that is usually less than 20 kV. Since at this point any magnetospheric model could only describe southward IMF cases with any reasonable certainty, all northward IMF crossings must be excluded. Eventually some sort of sophisticated pattern recognition routine may be developed for this task, but for now the program uses the measured potential drop as a cutoff. If the potential drop is greater than or equal to 40 kV then the program continues on to the model selection routine. However, if the potential drop is less than 40 kV then the program sets IMODNUM equal to 0 as a flag for a northward IMF or otherwise unusable pass, and then branches to the next block. While there will be some cases of weakly southward IMF where the potential drop is less than 40 kV that will be cut because of this high value for the cutoff, it was decided to choose a high cutoff to insure that all northern IMF cases were excluded.

Block 3h: (*Scatter parameter*) This block checks for the continuity of the data during this pass and assigns a quality flag to it. The drift meter is designed to operate in a plasma environment consisting mostly of  $O^+$  ions. However there are times when the  $O^+$  density drops leaving a predominately  $H^+$  plasma. During those times the DM measurements become very scattered and noisy, sometimes to the point of being useless. These occasions usually occur in the polar cap region in the winter hemisphere. Obviously, these passes should be removed from consideration by a magnetospheric modelling program, but the question arises of how to make the program distinguish between a noisy pass and one that is highly structured. To insure that the region sampled is inside the polar cap, the program takes the thirty horizontal flow data points following the zero crossing point (using the index number IZEROCNT from block 3b as the starting index for the FLOWHC data) and examines the absolute values of the differences between each successive pair of points. At first a standard calculation of the variance of the data was tried, but ruled out as a usable measure of the scatter. There are times when a glitch occurs in the flow data producing a

spike in an otherwise continuous flow. If only one or two such glitches occur and the rest of the data is smooth, then that pass is still usable. However taking the variance of the velocity differences for such a pass gives a value higher than the variance of noisy pass. There was no way to set the value of the variance so that noisy passes were excluded without also sacrificing the usable passes containing a only glitch or two, so a more sophisticated algorithm was needed.

A closer examination of the magnitudes of the velocity differences led to a usable algorithm. It was found that the velocity differences for usable data (both smooth and structured) was generally less than 0.2 km/s, while noisy data produced changes of 0.2 to 0.6 km/s between successive points. Glitches produced jumps in velocity of over 0.6 km/s. Using this information the program can differentiate between the different types of jumps by counting the number of jumps between 0.2-0.6 km/s (I2SKIP) and greater than 0.6 km/s (I6SKIP) in this thirty point dataset. Any pass with no jumps greater than 0.2 km/s is considered continuous and counted as good (the flag IQFLAG is set equal to 2). An unusable pass is one with more than two glitches (I6SKIP > 4) or more than seven jumps of 0.2 to 0.6 km/s (I2SKIP > 7) in the thirty point dataset (thus IQFLAG is set equal to 0). Any pass that falls some where in between (i.e.-a pass that is somewhat noisy or else has one or two glitches) is considered fair and IQFLAG is set equal to 1.

#### 4.5 BLOCK 4: SAVING THE DATA

Block 4: (*Loading the datafile*) Now that all the analysis is completed, the data required for the database is loaded into the datafile MSMDATA.DAT. First the program writes the year, day of year, hour, and minute of the start of this pass into the file. This time is used to uniquely identify each pass in the database. Next the program writes the magnitude of the electrostatic potential maximum into the file, followed by its location in magnetic local time and invariant latitude. This process is repeated for the electrostatic minimum. As stated above, the sign on the invariant latitudes determines in which hemisphere the pass occurs. Finally, the potential

correction factor (PSICORFAC), the scatter quality flag (IQFLAG), and the Heppner-Maynard model number (IMODNUM) are written to the datafile. These three parameters also act as quality flags. If any one of them is zero, then this pass is unusable and should be disregarded. PSICORFAC = 0 means the spacecraft did not cross the polar region at a high enough magnetic latitude to measure a suitable potential drop. IMODNUM = 0 means the potential drop is less than 40 kV probably indicating a northward IMF. IQFLAG = 0 means the flow data in this pass is probably too noisy to be reliable. The decision to allow any one of the three parameters veto the use of the pass is necessary since relying entirely on one parameter alone could easily lead to mistakes. (For example: a pass in the southern hemisphere could miss the auroral region completely, which would be caught by PSICORFAC, while the flow data would be quite smooth and continuous, thus producing an IQFLAG of 2.)

At this point the program has completely finished analyzing this pass. The program automatically branches back to block 1b where it begins searching for the next pass and then repeats the entire procedure.

## 5.0 CONCLUSION AND FUTURE WORK

Over the past three years UTD has produced workable programs for analyzing the drift meter data from the DMSP SSIES package to produce a measure of the electrostatic potential distribution in the ionosphere on a routine basis for satellites in the 0600 1800 local time meridian. Current plans are to move onto the next phase of analysis by developing a large database of the potential data from the drift meter from which a statistical analysis can be performed. With over two and a half years of near continuous coverage of the ionospheric flow over both poles, the DMSP database probably represents one of the largest storehouses of ionospheric data ever developed. As DMSP F8 continues to return data and DMSP F10 replaces it for the 1990 1993 period, this storehouse will

grow larger. Plans call for the production of an indexed datafile to provide easily accessible data from each spacecraft. This database would eventually cover the entire lifetime of F8 (and will be followed by F10 and future DMSP spacecrafts). Another database would be generated containing some of the geophysical and ionospheric parameters of the previously mentioned database, but also include data describing the shape of the electrostatic potential distribution. The IMF data covering the first fourteen months of DMSP F8's lifetime has just recently become available through the National Space Science Data Center. A copy of that database is now accessible for future use in further studying the effect of the IMF on the ionospheric convection pattern.

We hope to be able to derive better and more complete convection models from this data, as well as a better understanding of the evolution of the convection patterns in response to changes in the IMF. With such a large statistical base it should be possible to make reasonably valid descriptions of the convection pattern and potential distribution for times when the available data from satellites is incomplete or of too poor a quality to be used. As we improve our convection model, we will incorporate other data sets (such as radar observations of the ionospheric flow) as a check on the validity of the models. This database will also provide a valuable resource for various ionospheric and magnetospheric specification models for use by the Air Force.

## APPENDIX A: COROTATION CORRECTION ALGORITHM

In all the physics described in this report, it is assumed that the convection flow pattern is being measured in a frame of reference that is fixed in space relative to the sun-Earth line. For a satellite orbiting a non-rotating planet, measuring this convection flow would be a simple matter, the observed flow would be the convection flow. The Earth, however, is rotating, and that means that the flow observed by the satellite is some mixture of the flow from the convection pattern and the flow arising from the ionospheric plasma corotating eastward with the Earth. The corotation correction subroutine (CCROTFIX) contains an algorithm for calculating the amount of corotation flow at every point along the satellite's track and removing that component from the flow data. For this algorithm it is assumed that the Earth is in a cylindrical coordinate system with the  $z$ -axis aligned along the Earth's spin axis and the origin set at the center of the Earth. (Note: this should not be confused with the  $x$ - $y$ - $z$  coordinate system of the spacecraft itself where  $+x$  always in the direction of the spacecraft's velocity vector and  $+z$  is oriented away from the center of the Earth through the spacecraft's current position.) In such a coordinate system the corotation flow is limited to the  $+\phi$  direction. Since the Earth rotates at a constant angular frequency of  $\omega_E$  the magnitude of the corotation at any geographic latitude is given by:

$$v_{corotation} = d * \cos(latitude) * \omega_E \quad (A.1)$$

where  $d$  is the distance from the center of the Earth to the satellite (i.e.-the altitude of the satellite plus the radius of the Earth). In examining the effect of corotation in all possible orbits, there are two limiting cases: a satellite in a purely equatorial orbit (inclination =  $0^\circ$ ) and a satellite in a purely polar orbit (inclination =  $90^\circ$ ). In a purely equatorial orbit the satellite is moving parallel to a constant corotation flow, thus the correction is merely a constant value added to all flow data measured in the  $x$  direction (parallel flow component). In a purely polar orbit the satellite is always moving at right angles to the corotation flow. Thus the corotation correction

affects only the flow data in the  $y$  direction (horizontal flow component) and the magnitude of the correction varies sinusoidally over the course of one orbit. (The corotation component is positive during the northbound leg of the orbit, reaching a maximum at the equator and zero at both poles. Consequently, the corotation component is negative during the southbound leg of the orbit, reaching a minimum at the equator.) A satellite in an orbit with any other inclination will require a correction that is a mixture of both cases. The correction algorithm must keep track not only of the magnitude of the corotation flow component, but must also keep track of the angle between the satellite's velocity vector and the corotation flow vector. This angle is necessary in order to properly distribute the corotation correction between the  $x$  and the  $y$  components of the measured flow.

The DMSP satellites orbit the Earth with an inclination of  $98.7^\circ$  and thus the algorithm in DMSPPOTMOD2 must calculate both the magnitude of the corotation component and the angle between the spacecraft velocity vector and the corotation vector. Since the derivation of the electrostatic potential from the flow data requires only the  $y$  and  $z$  (horizontal and vertical) flow components, the correction will only be applied to the  $y$  component. (The  $z$  component is always perpendicular to the corotation flow and thus is never affected by it. A correction to the flow in the  $x$ -direction can be easily added on in later versions of the program if a need for it arises.) In the first pass through the data in the IDMREAD subroutine the program calculates the magnitude of the corotation flow and the corotation correction for the  $y$  component of flow data at the first second of each minute of data. The program takes the  $x$ - $y$ - $z$  position of the satellite in the Earth-centered inertial (ECI) coordinates for this minute and the  $x$ - $y$ - $z$  position from the previous minute, then uses them to determine the velocity vector of the spacecraft between those two positions. (This calculation is the reason why it is necessary for the program to read the extra "bracket minutes" mentioned in the discussions above about block 1c and the subroutine COROTFIX.) A rotational

transformation of the coordinates about the  $z$ -axis is first performed in order to set the current position of the spacecraft in the  $y = 0$  plane. Since the angle between the spacecraft velocity vector and the corotation flow vector is independent of the longitude of the spacecraft, this rotation merely simplifies the calculation by always making the  $+\phi$  corotation flow parallel with the  $+y$  component. This angle  $\sigma$  (SIGMA) is calculated by taking the arccosine of the change in the  $y$  component divided by the total length of the velocity vector. Since arccosine always returns a positive value, a check on the sign of the change in  $z$  is done to determine the sign of SIGMA (positive if the spacecraft is heading northward, negative for southward). The corotation velocity (CORVEL) at that point is then calculated using equation A.1 above. The correction to the  $y$  component of the flow data for the corotation flow (CORCOR) is given by:

$$CORCOR = CORVEL * \sin(\sigma) \quad (A.2)$$

The geometry of this situation is shown in figure 8. The program then continues to the next minute of data storing each of the corrections for the first second of each minute in the array CORCOR until the reading of the pass is completed.

Once all the corotation corrections (CORCOR) for each minute have been calculated, they can now be used to correct the  $y$  component of flow data in the array FLOWH. This correction is performed in the subroutine COROTFIX. For each minute of flow data the program takes the corotation correction for the beginning of that minute and the corotation correction for the next minute, then does an interpolation for each flow data point every four seconds during that minute. The program removes the calculated corotation component from each element in the array FLOWH and then replaces each element in the array with the corrected horizontal flow velocity. At the end of the correction the program proceeds with the calculations of the electrostatic potential using the corrected flow values.

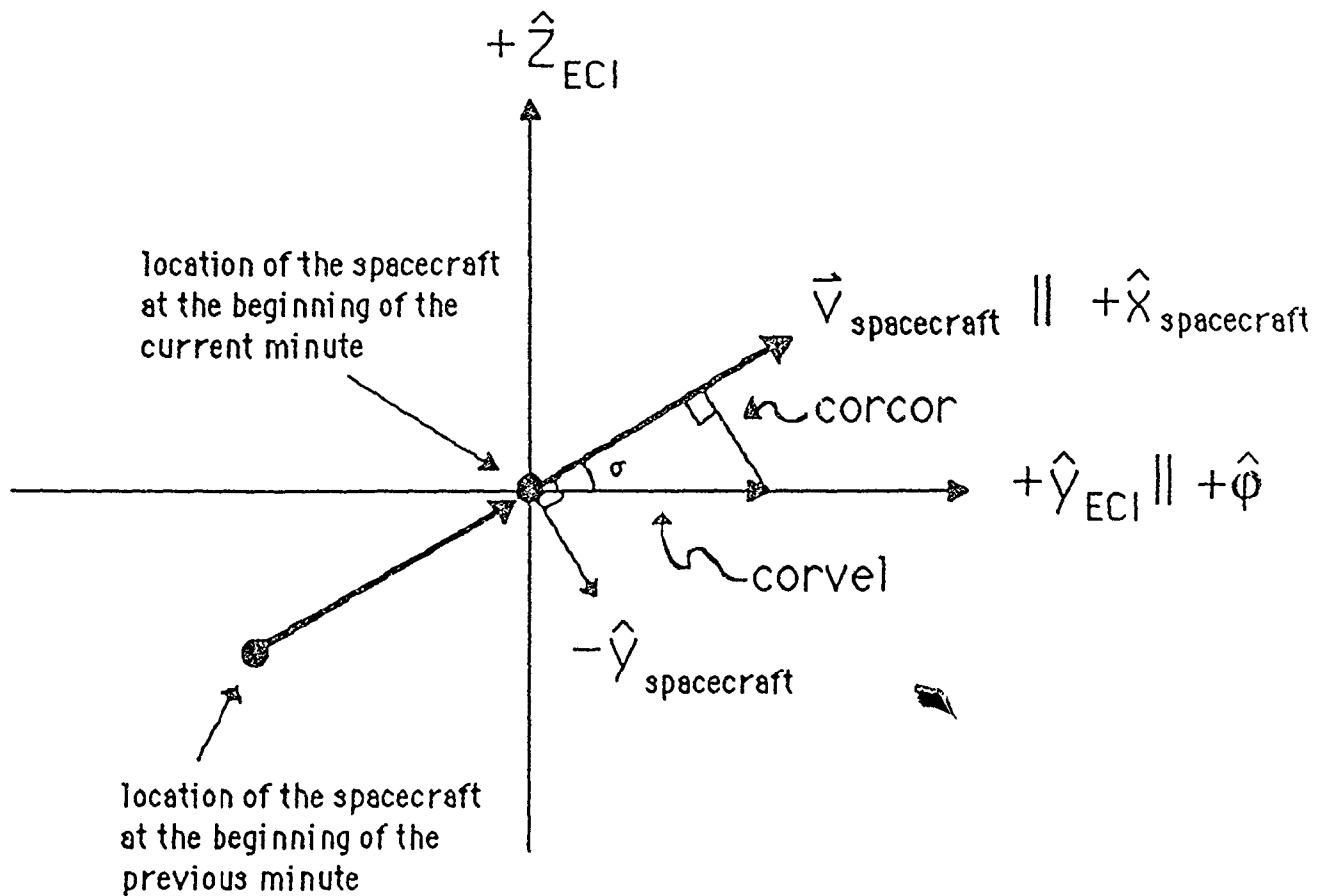

Figure 8. The geometry of the corotating ion flow relative to the moving spacecraft. The spacecraft is placed at the center of this picture such that the corotational flow in the  $+\phi$  direction is parallel to the  $+y$  direction in the ECI coordinate system. The corotational flow is shown by the vector labelled "corvel". The velocity vector of the spacecraft is at the angle  $\sigma$  to the corotational flow. Since the velocity vector is parallel to the  $+x$  component of the spacecraft coordinate system and the  $+z$  component of the spacecraft coordinate system is perpendicular out of the page, then the corotation correction to the horizontal flow ("corcor") is given by  $CORCOR = CORVEL * \sin(\sigma)$ .

## REFERENCES

- Delorey, D. E., P. N. Pruneall, and C. M. Parsons. Database development for the DMSP SSIES experiment, Air Force Geophysics Laboratory Technical Report, AFGL-TR-89-0066, 28 February 1989, ADA208712.
- Greenspan, M. E., P. B. Anderson, J. M. Pelagatti, Characteristics of the thermal plasma monitor (SSIES) for the Defense Meteorological Satellite Program (DMSP) spacecraft S8 through S10. Air Force Geophysics Laboratory Technical Report, AFGL-TR-86-0227, revised version April 1988, ADA176924.
- Hairston, M. R., and R. A. Heelis, Determination of the ionospheric convection pattern from DMSP data, *Physics of Space Plasma (1988)*, T. Chang, G. B. Crew, and J. R. Jasperse, eds. (Scientific Publishers, Cambridge, Mass., 1989) pp. 391-396. (Also available as technical report AFGL-TR-88-0298, August 1988, ADA201121).
- Hairston, M. R., and R. A. Heelis, Model of the the high-latitude ionospheric convection pattern during southward interplanetary magnetic field using DE 2 data. *J. Geophys. Res.*, *95*, 2333-2343, 1990.
- Hargreaves, J. K., *The Upper Atmosphere and Solar Terrestrial Relations*. Van Nostrand Reinhold Co., New York, 1979.
- Heelis, R. A., J. K. Lowell, and R. A. Spiro, A model of the high-latitude ionospheric convection pattern, *J. Geophys. Res.*, *87*, 6339-6345, 1982.
- Heppner, J. P., and N. C. Maynard, Empirical high latitude electric field models, *J. Geophys. Res.*, *92*, 4467-4489, 1987.

Sojka, J. J., C. E. Rasmussen, and R. W. Schunk, An interplanetary magnetic field dependent model of the ionospheric convection electric field, *J. Geophys. Res.*, 91, 11281-11290, 1986.

Tascione, Thomas F., *Introduction to the Space Environment*, Orbit Book Co., Malabar, Florida, 1988.