

Material Capability for Transport of Unsymmetrical Dimethylhydrazine

K. P. CROSSMAN,* J. R. WYATT AND S. L. ROSE-PEHRSSON

*Chemistry Dynamics and Diagnostic Branch
Chemistry Division*

**GEO-Centers, Inc.
Fort Washington, MD*

July 13, 1990

AD-A224 166

DTIC
ELECTE
JUL 25 1990
S B D

REPORT DOCUMENTATION PAGE			Form Approved OMB No. 0704-0188	
Public reporting burden for this collection of information is estimated to average 1 hour per response, including the time for reviewing instructions, searching existing data sources, gathering and maintaining the data needed, and completing and reviewing the collection of information. Send comments regarding this burden estimate or any other aspect of this collection of information, including suggestions for reducing this burden, to Washington Headquarters Services, Directorate for Information Operations and Reports, 1215 Jefferson Davis Highway, Suite 1204, Arlington, VA 22202-4302, and to the Office of Management and Budget, Paperwork Reduction Project (0704-0188), Washington, DC 20503.				
1. AGENCY USE ONLY (Leave blank)	2. REPORT DATE 1990 July 13	3. REPORT TYPE AND DATES COVERED Final		
4. TITLE AND SUBTITLE Material Capability for Transport of Unsymmetrical Dimethylhydrazine		5. FUNDING NUMBERS PE - 6441F WU - 51-2172-0-9		
6. AUTHOR(S) Karen P. Crossman,* J.R. Wyatt, S.L. Rose-Pehrsson				
7. PERFORMING ORGANIZATION NAME(S) AND ADDRESS(ES) Naval Research Laboratory Washington, DC 20375-5000		8. PERFORMING ORGANIZATION REPORT NUMBER NRL Memorandum Report 6679		
9. SPONSORING/MONITORING AGENCY NAME(S) AND ADDRESS(ES) USAF HQ/Space Division Los Angeles AFB Los Angeles, CA 90009-2960		10. SPONSORING/MONITORING AGENCY REPORT NUMBER		
11. SUPPLEMENTARY NOTES *Geo-Centers, Inc.				
12a. DISTRIBUTION/AVAILABILITY STATEMENT Approved for public release; distribution unlimited.		12b. DISTRIBUTION CODE		
13. ABSTRACT (Maximum 200 words) Materials were evaluated for potential use as ambient air sample lines for unsymmetrical dimethylhydrazine (UDMH) and hydrazine. FEP (a fluorinated polymer) and high density polyethylene tubing materials reached the maximum response levels for TLV and lower concentrations of UDMH. Sample lengths of 23m and 61m were investigated for their effect on performance. Other areas examined were humidity, conditioning the sample tubing, and cleaning agents. High density polyethylene performed the best after ambient air conditioning of the tubing.				
14. SUBJECT TERMS Unsymmetrical dimethylhydrazine, Sample transport, Hydrazine,		Tubing, Vapor detection - (D)		15. NUMBER OF PAGES 42
17. SECURITY CLASSIFICATION OF REPORT UNCLASSIFIED		18. SECURITY CLASSIFICATION OF THIS PAGE UNCLASSIFIED		16. PRICE CODE
19. SECURITY CLASSIFICATION OF ABSTRACT UNCLASSIFIED		20. LIMITATION OF ABSTRACT UL		

CONTENTS

INTRODUCTION	1
TEST AND EVALUATION PROTOCOL	2
EXPERIMENTAL	4
RESULTS AND DISCUSSION	6
Initial UDMH Screening Exposures	6
Relative Humidity Effects	9
Hydrazine Exposures	18
Preconditioning of Tubing by Ambient Exposure	23
Effects of Cleaning Agents	23
CONCLUSIONS	26
REFERENCES	27
APPENDIX	29



Accession For	
NTIS GRA&I	<input checked="" type="checkbox"/>
DTIC TAB	<input type="checkbox"/>
Unannounced	<input type="checkbox"/>
Justification	
By _____	
Distribution/	
Availability Codes	
Dist	Avail and/or Special
A-1	

MATERIAL CAPABILITY FOR TRANSPORT OF UNSYMMETRICAL DIMETHYLHYDRAZINE

INTRODUCTION

The use of hydrazine (Hz), monomethyl hydrazine (MMH), and unsymmetrical dimethyl hydrazine (UDMH), especially as high energy propellants, has increased dramatically in recent years. Substantial quantities of hydrazines are used as propellants in Titan ballistic-missiles, satellites, and aircraft auxiliary-power units. With this increased usage, concern has developed over the toxicological properties of the hydrazines.

Studies indicate that exposure to hydrazines may cause damage to the liver, kidneys, and other internal organs and may produce blood abnormalities. Hydrazines not only cause physical damage but also alter the behavior of personnel by significantly decreasing performance capabilities [1]. A recent study cites irreversible damage to the nervous system as a possible consequence of hydrazines exposure [2]. Effects in man can be teratogenic as well as mutagenic. The adverse effects extend to nonmammalian life forms, thereby potentially endangering the environment.

Since the hydrazines are suspected carcinogens, a maximum tolerated toxic level has been set at five parts-per-million (ppm). The American Conference of Governmental and Industrial Hygienists (ACGIH) has recommended the threshold limit values (TLV) of Hz, MMH, and UDMH to be 100, 200, and 500 parts-per-billion (ppb), respectively [1]. Potentially this level may be lowered to 10 ppb for all three hydrazines [3]. To protect personnel from overexposure, NASA, the Air Force, and the Department of Defense, require air monitoring for hydrazines in areas where they are handled and/or stored.

For several reasons, it is desirable to monitor a number of these potential exposure sites with one fixed-point analyzer. The analyzer would sample through a network of tubing in which sections may be 61 m (200 ft) or more in length. For many ambient air contaminants this method of sampling would pose no addition problems, but due to the reactive nature of hydrazines and their known interaction and decomposition on surfaces, the transport tubing could significantly affect the concentration of hydrazines reaching the analyzer. This is particularly a concern when measuring the sub-ppm levels necessary with hydrazines.

This report describes the results of a materials compatibility study comparing the ability of several commercially available tubings to transport levels of UDMH at TLV and lower concentrations under various conditions. In addition, several of the tubings were spot checked with hydrazine. Most of the studies in this report used UDMH as the work was funded by the Air Force Space Division. The liquid fuel used in the Titan missile is Aerozene-50, which is a 50:50 mix of UDMH

and hydrazine. The vapor pressure of UDMH is 10 times greater than that of hydrazine. Therefore, a spill of the liquid will initially result in a 10 times greater vapor concentration of UDMH than hydrazine.

The objective of this study was to determine which tubing type(s) optimally transport UDMH contaminated air. Variables studied for their effects on tubing performance include: relative humidity (RH), length of tubing, conditioning with ambient air, and various wash solutions. An extensive tubing survey was conducted in 1985-1986 for MMH. A memorandum report describing the results was published [4]. The current project was designed to investigate many of the same parameters for UDMH and to spot check with hydrazine. This study was approached as a survey rather than a statistical analysis due to the time allotted and the number of variables to be investigated. This report supplements our previous report by including tests with the other hydrazine fuels.

TEST AND EVALUATION PROTOCOL

The wall adsorption characteristics of several tubing materials were examined using 0.5 ppm UDMH in air at room temperature humidified to approximately 40-60% RH. Table 1a lists the tubings tested during the evaluation. Table 1b details the chemical composition of those tubings [5]. The tubing characteristics were determined by comparing the response of the analyzer to a known concentration gas stream with and without a coil of test tubing in place between the instrument and the gas generation system. All of the initial tests were conducted using 23 m, 0.63 cm (75 ft, 1/4 in) internal diameter tubing of the following types: Teflons (PFA, FEP, TFE), Polyethylene, High Density Polyethylene, Polypropylene, and Bev-A-Line [6]. Bev-A-Line tubing with an internal diameter of 0.95 cm (3/8 in) was also examined.

In addition, the better materials were tested in lengths up to 61 m (200 ft). The effect of relative humidity on these materials was examined with a known UDMH concentration. Response time for hydrazine at 0.1 ppm was also investigated. The effect of aging and deterioration was investigated by exposing these materials to ambient air for one month prior to UDMH exposure. Alternative cleaning methods, including both gases and liquids, were investigated for materials exposed to prolonged ambient conditions.

All tests were conducted using air generated by the NRL gas generation system which is described in detail in the Experimental section. The response times to first indication, 50%, 75%, 90%, and maximum response were recorded. The 23 m lengths were tested for a maximum of 60 minutes. The longer tubing was examined for a longer period of time if needed. The tubing exposures to UDMH continued for up to eight hours following the prolonged ambient air exposure if needed. Tubing was cleaned by flushing with methanol and purged with clean air between each test.

Table 1a. Tubings Evaluated

Tubing Type	Reference	OD (in)	ID (in)	Supplier	Manufacturer
Bev-A-Line IV	BAL	3/8	1/4	Read	Thermoplastic Scientific
Bev-A-Line IV	BAL 1/2	1/2	3/8	Read	Thermoplastic Scientific
TFE Teflon	TFE	3/8	1/4	Read	Atlantic Tubing Company
PFA Teflon	PFA	3/8	1/4	Read	Atlantic Tubing Company
FEP Teflon	FEP	3/8	1/4	Read	Atlantic Tubing Company
High Density Polyethylene	HDPE	3/8	1/4	Read	Hudson Extrusions Inc.
Polypropylene	PP	3/8	1/4	Read	Atlantic Tubing Company
Polyethylene	PE	3/8	1/4	NRL	unknown

Read: Read Plastics, Rockville MD

NRL: Naval Research Laboratory

Table 1b. Chemical Composition of Tubing Materials

Tubing Type	Reference	Chemical Composition
Bev-A-Line IV	BAL	polyethylene liner, ethyl vinyl acetate shell
Bev-A-Line IV	BAL 1/2	polyethylene liner, ethyl vinyl acetate shell
TFE Teflon	TFE	tetrafluoroethylene
PFA Teflon	PFA	tetrafluoroethylene - perfluoropropyl vinyl ether
FEP Teflon	FEP	tetrafluoroethylene - hexafluoropropylene
High Density Polyethylene	HDPE	high density polyethylene
Polypropylene	PP	polypropylene
Polyethylene	PE	polyethylene

EXPERIMENTAL

A schematic of the test apparatus is shown in Figure 1. The air supply was house compressed air conditioned by passing it through a series of demisters, a hot Hopcalite catalyst bed, a reciprocating dual-tower molecular-sieve scrubber, and finally through a canister containing potassium permanganate coated alumina (PURAFIL) and charcoal. The clean air was rehumidified using a stainless steel gas washer (bubbler) containing distilled, deionized water. Control of relative humidity was achieved by varying both the gas washer head pressure and the ratio of rehumidified to dry air. A mass flow controller passed zero grade, humidified air through a chamber where the humidity was measured by a hygrometer. The amount of diluent air varied from 5.9 l/min to 7.9 l/min depending on the desired concentration of UDMH or hydrazine. The UDMH or hydrazine gas stream flowed into one of two pyrex glass manifolds. Similarly humidified zero grade air was passed into the other manifold. The analyzer and the coil of tubing to be tested were connected to the manifold system by a two-way Teflon valve and a Teflon tee. The valve controlled the flow of clean air or contaminated gas from the manifold system. An auxiliary pump was used in conjunction with the analyzer to pull a total of 3 l/min through the coil of tubing to be tested.

Unsymmetrical dimethylhydrazine and hydrazine vapors were generated from diffusion tubes held at a constant temperature in a water bath. The UDMH or hydrazine was swept from the diffusion tube with 100 ml/min dry nitrogen to the above mentioned manifold system. Impinger samples were collected at the contaminated gas manifold to verify the concentration and were analyzed by coulometric titration with bromine using amperometric endpoint detection. The coulometric method is the NRL/NASA-White Sands modification of reference 7, in which we miniaturized the system to improve sensitivity. This concentration measurement was performed before and after each tubing challenge test.

Real-time monitoring of ppb levels of UDMH and hydrazine was accomplished using one of two instruments. The majority of tests utilized the Thermedics Model 141-1 hydrazine analyzer (TECO), which is a chemiluminescence-based instrument. The Thermedics analyzer sampled a 1.5 l/min portion of the air flowing through the tubing. The response time of this instrument is a few seconds which is considered to be real-time for our purposes. The results used for comparison were normalized to the full scale deflection (FSD) of the instrument, which was established during the concentration verification procedure, before and after each test. During the evaluation procedure, numerous problems were encountered with the instrument and it was replaced with an MDA Scientific Inc., Model 7100 instrument. The MDA 7100 is a commercially available paper tape instrument which measures the color change that develops upon exposure to a hydrazine. The intensity of the color is proportional to the concentration. The color is measured and the concentration is printed every minute. This technique has few interferences and worked well in these studies.

A typical tubing UDMH or hydrazine challenge experiment consisted of three steps. First, the contaminated air stream was sampled through a 1.8 meter long, 0.32 cm I.D. teflon tube and the maximum reading was established and recorded. Simultaneously the UDMH or hydrazine concentration was measured by coulometric analysis. These values were later used to calculate the

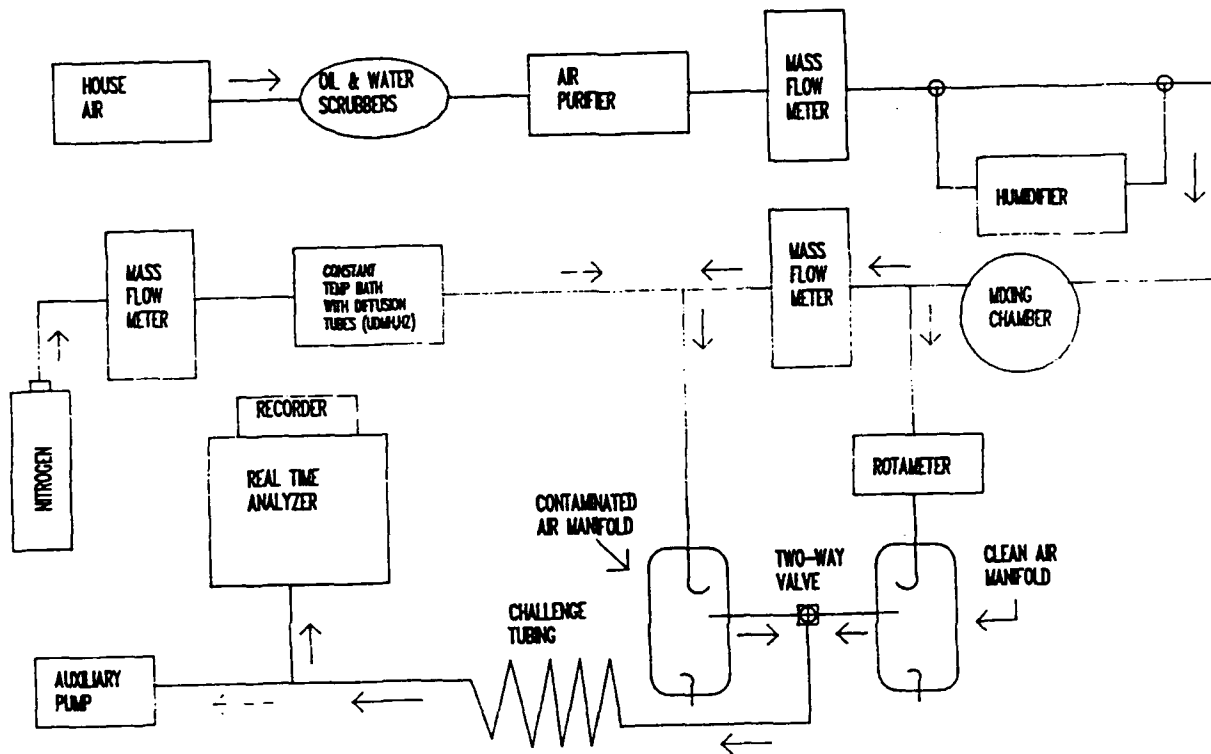

Figure 1. Apparatus for Evaluation of Tubing Materials

amount of UDMH or hydrazine transported by a coil of sample tubing in comparison to the amount detected without the coil. Next, the two-way valve shown in Figure 1 was switched to sample clean air. When the concentration of the hydrazine dropped below detectable limits (about 10 ppb) the subject tubing was inserted between the two-way valve and the 1.8 m tubing. A throttle valve on the auxiliary pump was adjusted so the total flow through the tubing was 3 l/min. The tubing was allowed to equilibrate by flowing humidified clean air through it for approximately 10 to 20 minutes. The two-way valve was switched to contaminated air, allowing the instrument to sample UDMH or hydrazine gas from the manifold.

When the instrument response to UDMH or hydrazine stabilized, the two-way valve was switched to clean air. The instrument response was allowed to return to baseline level and the challenge tubing was removed from the test system. The contaminated air stream was again sampled through the 1.8 meter tubing to monitor the maximum reading.

An example of the data is shown in Figure 2. This data was used to determine the times required to reach first indication, 50, 75, 90, and 100 percent of the challenge gas concentration without the tubing coil in place. The first indication and the time to 50 percent were comparable in many cases. When 100 percent transport was not achieved, the maximum percentage of UDMH or hydrazine transported and the time required to reach that value was recorded.

At the end of a test, the tubing was rinsed with methanol and dried with compressed breathing air or filtered compressed house air. Solvents such as acetone were not used as they react with hydrazines [8].

Table 2 lists the combinations of tubing length, UDMH or hydrazine concentration, and relative humidity (RH) which were examined. Relative humidities from 0 to 86% were selected to mimic, as closely as possible, the extremes of expected field conditions. Tubing in 23 m lengths were exposed to contaminated air for a maximum of 60 minutes. Sixty-one meter lengths were exposed until the readings were stable. With few exceptions, each test was run at least three times. The initial testing of 23 m lengths at TLV UDMH were repeated up to eight times. All of the figures in the Results Section reflect the average of all the exposure results for a given series of tests. Variations and additions to the experimental set-up and design are discussed where applicable in the next section. The appendix includes tables of all data obtained.

RESULTS AND DISCUSSION

Initial UDMH Screening Exposures

The results were very erratic in many of the tests. The fluctuations occurred for each tubing under different conditions. The selection of candidate tubings for testing at 23 m lengths was based on known or assumed compatibility with hydrazines. A 23 m length of 0.635 cm (0.25 in) ID tubing has a volume of 0.73 l, hence the minimum response time is 0.24 min. For a 61 m length of tubing with the same ID, the volume is 1.9 l and the minimum response time is 0.64 min. The first series

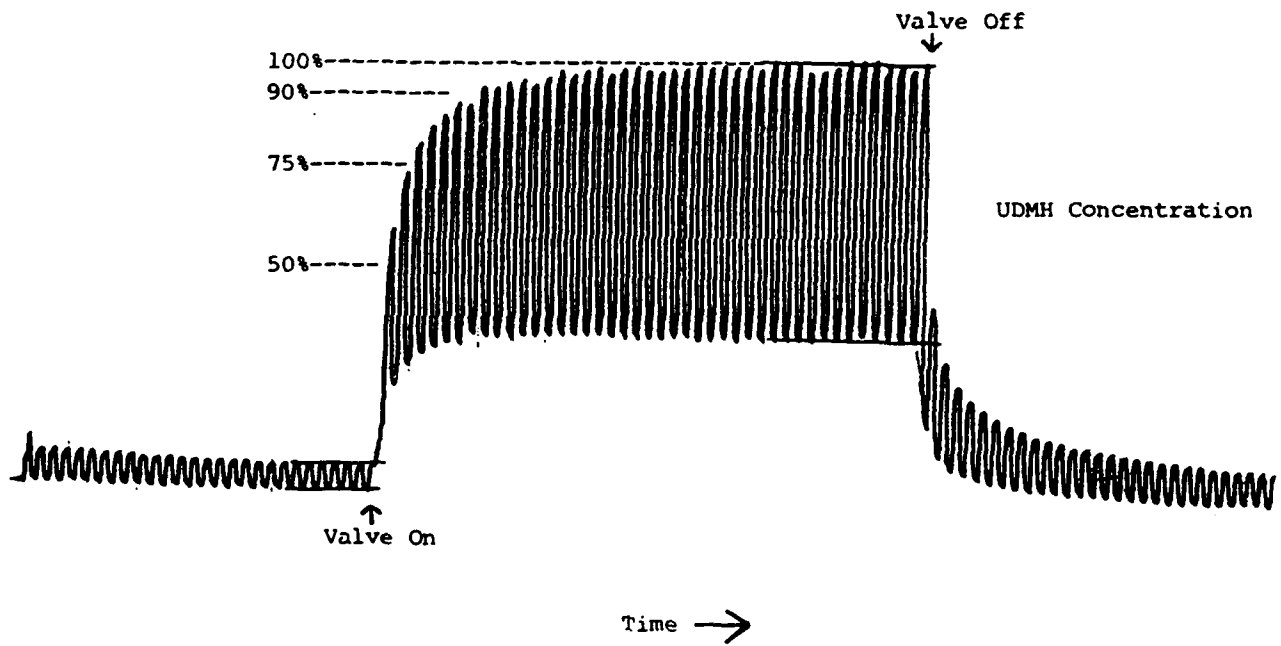

Figure 2. Instrument response to UDMH through subject tubing. This is a chart recorder trace from the TECO which cycles between sample and background channels. Unlike MMH and hydrazine, UDMH produces a response in the background channel.

Table 2. Parameters for Tubing Evaluation

Gas	Gas Conc. (ppb)	Tubing Length (m)	Tubing Length (ft)	RH (%)
UDMH	300	23	75	0
UDMH	300	23	75	37
UDMH	500	23	75	0
UDMH	500	23	75	37
UDMH	500	61	200	0
UDMH	500	61	200	37
UDMH	500	61	200	85
UDMH	250	61	200	0
UDMH	250	61	200	37
UDMH	250	61	200	85
Hydrazine	100	61	200	37
Hydrazine	150	61	200	37
Hydrazine	200	61	200	37

of tests involved TLV levels of UDMH at 35% RH. Figure 3 shows the response times to 50, 75, and 90% of UDMH transported down the various tubing types. Polypropylene (PP), TFE, and polyethylene (PE) displayed the shortest response times, while PFA consistently gave the longest response time to 90% at 12 minutes. High density polyethylene (HDPE) and Bev-A-Line (BAL) gave the widest range in response times to 90%. HDPE achieved 90% in 3.0 to 24.3 minutes, while BAL required from 1.4 to 18.0 minutes to reach 90% of transport. Of the tubings tested, FEP gave the most repeatable response times to 90%. It reached 50% in 1.2 to 6.3 minutes. At these conditions, all of the tubings transported 100% of the UDMH; however, polyethylene and TFE reached 100% in 4 out of 7 exposures.

All 23 m lengths of tubing with the exception of FEP and PFA were exposed to TLV UDMH at 0% RH. Figure 4 shows the pertinent data in a bar graph. The results were very inconsistent from test to test for high density polyethylene and TFE. High density polyethylene responds to 90% from 0.9 to 24.9 minutes, while the range in response times to 90% for TFE is 1.8 to 26.9 minutes. Although the response time to the 90% level for polyethylene appears short, the tubing reached 90% in only 2 out of 3 tests. Therefore, it also gives inconsistent response times.

Figure 5 shows the response times of 23 m lengths of several types of tubings at 300 ppb of UDMH and 35% RH. All tubings achieved the 50% level with comparable response times. With the exception of the 6.0 minute response time to 75% of full scale for polypropylene, the tubings attained 75% with comparable response times. The average response times to 90% vary between tubing types. However, the greatest variations were in replicate exposures of each tubing. The response times for polypropylene at 90% were the most nonrepeatable. In one test the response time to 90% was 7 minutes, while in another test the tubing never reached 90% during the 60 minute exposure. Polyethylene and Bev-A-Line also gave very erratic response times from test to test.

At this point in the evaluation period, four of the tubings tested at 23 m were chosen to complete the test plan. These were Bev-A-Line, polyethylene, FEP teflon, and high density polyethylene. None of the tubings out-performed the others; therefore, they were chosen on the basis of cost, possibility of crimping, and flexibility.

Relative Humidity Effects

Sixty-one meter lengths of tubing were used in the next series of tests. The effects of relative humidity (% RH) and varying concentrations of UDMH and hydrazine were investigated. The tubings were exposed to TLV UDMH at 0% RH. Response times to first indication and 50% of transport were comparable between the four tubings. With the exception of the 4.7 minute response time to 75% for Bev-A-Line, the tubings performed similarly to 75% of full scale. The response times to 90% varied as shown in Figure 6. FEP showed the shortest response time to 90%, while Bev-A-Line never reached 90% during the exposures. Polyethylene and high density polyethylene reached 90% in 3 out of 4 tests.

At TLV UDMH and 35% RH, the response times to first indication and 50% were comparable for all four tubings. At 90%, the polyethylene, high density polyethylene, and Bev-A-Line tubings

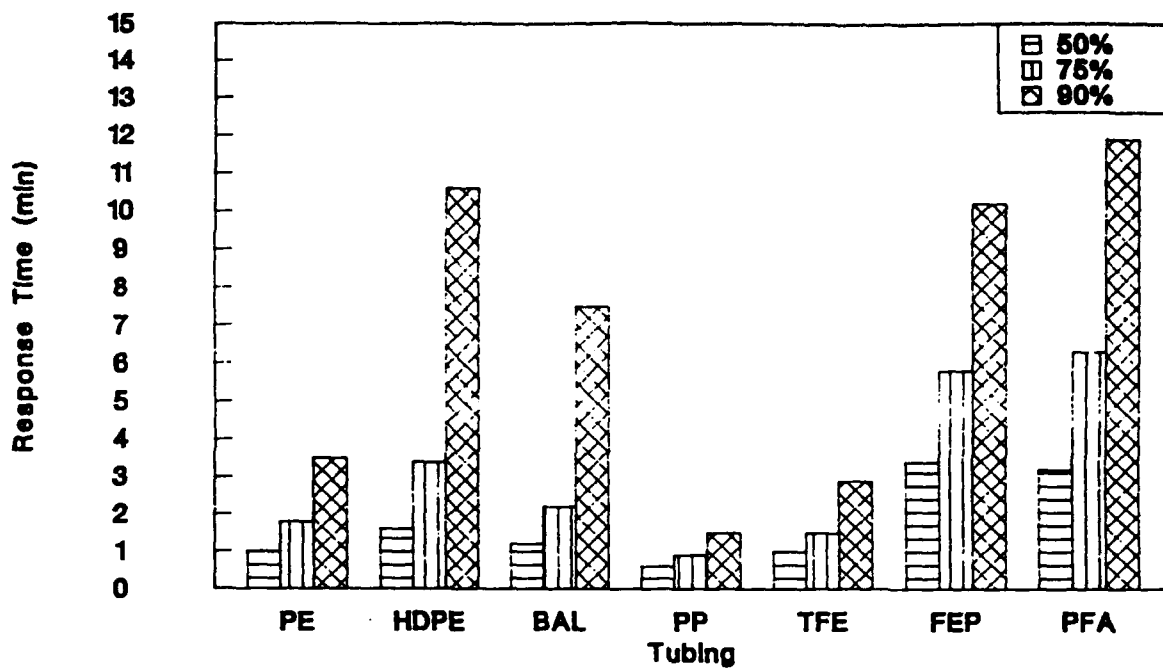

Figure 3. Response times of 23 m (75 ft) of tubing to TLV UDMH at 35% RH

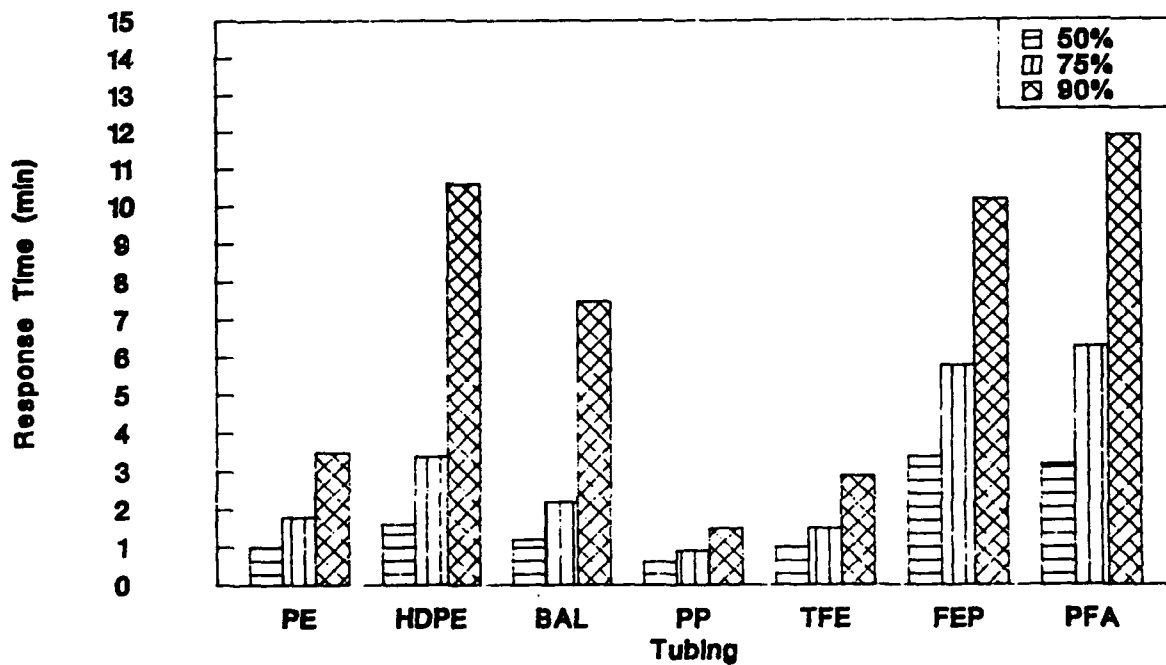

Figure 4. Response times of 23 m (75 ft) of tubing to TLV UDMH at 0% RH

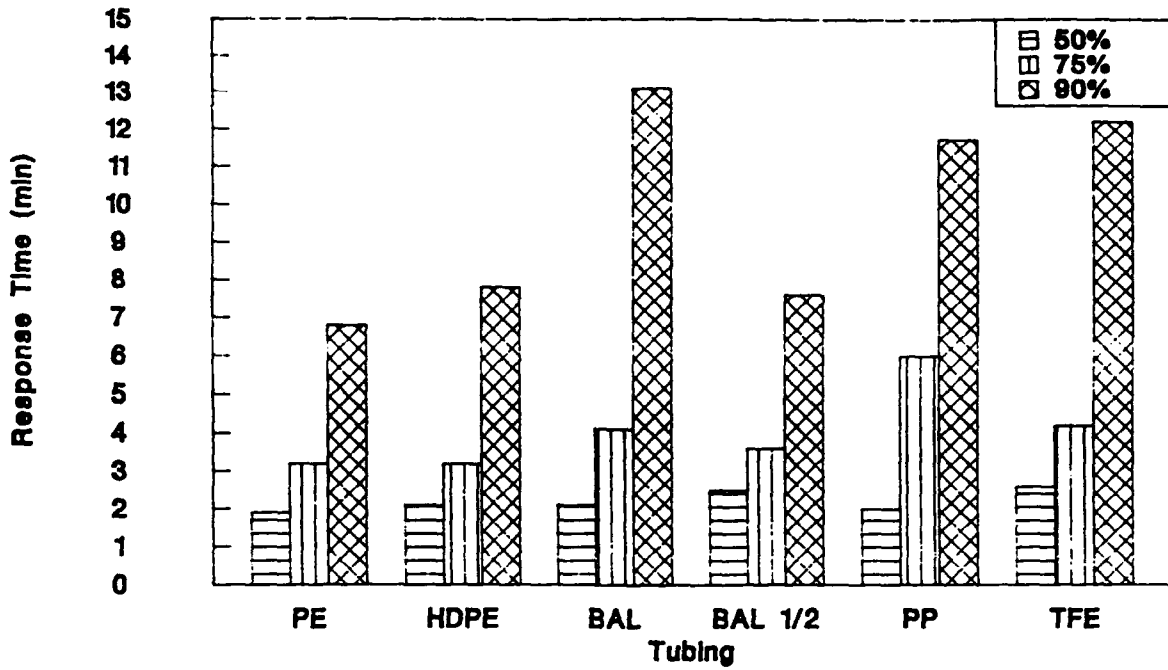

Figure 5. Response times of 23 m (75 ft) of tubing to 300 ppb of UDMH at 35% RH

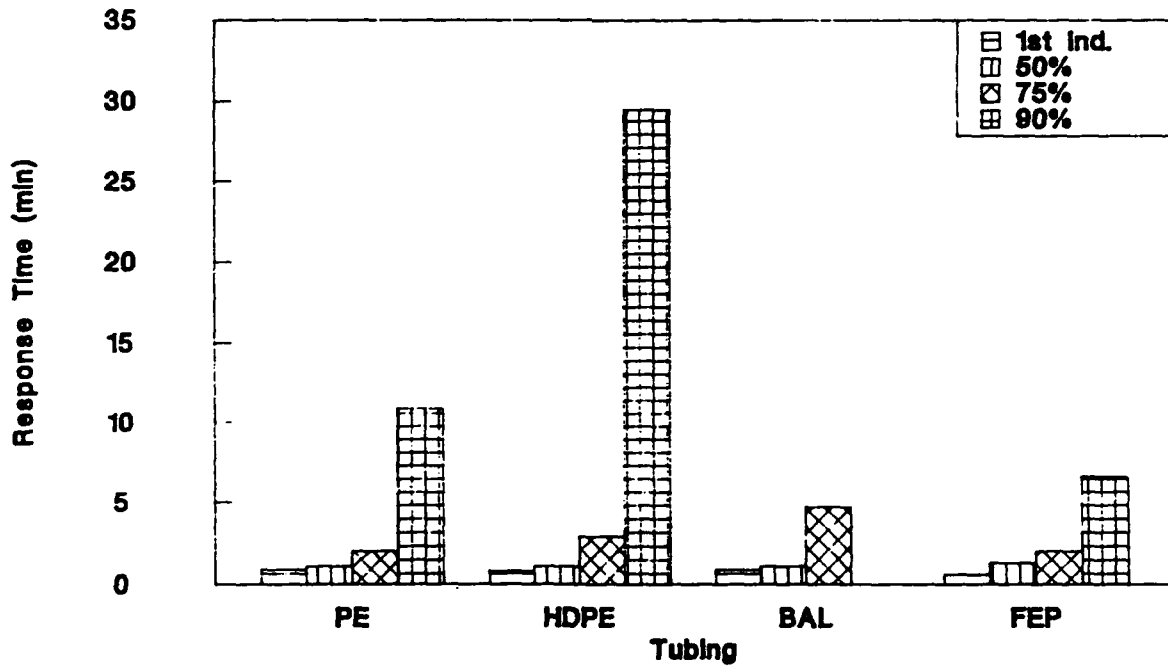

Figure 6. Response times of 61 m (200 ft) of tubing to TLV UDMH at 0% RH

responded similarly. The FEP gave much shorter response times to 75% and 90%. Figure 7 shows the various response times at these conditions.

The MDA 7100 was used for the polyethylene and HDPE tubing samples for exposure to TLV UDMH at 80% RH. These two tubings were exposed to these conditions later in the testing period after the Thermedics instrument had ceased to function properly. As shown in Figure 8, the shortest response times to 50%, 75%, and 90% were attained by high density polyethylene, while FEP had the shortest time to first indication. High density polyethylene reached 90% by 20 minutes. It took the polyethylene almost 50 min to attain 90% of full scale. The response times to 90% of Bev-A-Line and FEP fall within those of high density polyethylene and polyethylene.

The aforementioned tubings were also exposed to approximately 250 ppb (half the TLV) of UDMH at 0, 45, and 85% RH. Figures 9, 10, and 11 show the data for these exposures. At 0% and 45% RH, the response times to first indication are comparable for all tubings. At 85%, the response times to first indication are twice as long as those at 0% and 45% RH. At all three humidities, the response times to 50%, 75%, and 90% for polyethylene tubing were longer than the other tubings. At 0% RH, polyethylene did not reach 90% for any of the exposures to UDMH. High density polyethylene and Bev-A-Line reached 90% in 2 out of 3 exposures. FEP performed the best, reaching 90% in 15 minutes. At 45% RH, FEP appeared to perform the best, however, it only reached 90% in 1 out of 3 tests. Polyethylene achieved 90% full scale in 2 out of 3 tests. At 85% RH, polyethylene achieved 90% in only 1 out of 3 tests.

Comparisons can be made between exposures of 61 m of tubing to TLV UDMH and the same length of tubing at 250 ppb. Most of the tests showed a faster response at higher concentrations. Bev-A-Line and polyethylene responded more quickly to TLV levels of UDMH than to half that concentration at all the humidities tested. High density polyethylene responded faster to TLV UDMH at 0% and 85% RH. At mid range RH, the tubing gave shorter response times when exposed to one-half TLV. The FEP tubing responded to TLV UDMH at 0% RH fairly quickly. At 45%, the tubing reached 90% of full scale at one-half TLV quickly, however, it only attained 90% in 1 out of 3 exposures. At low and mid range RH, FEP gave quicker response times when exposed to TLV levels of UDMH. At high humidity, FEP attains 50, 75, and 90% of full scale faster at 250 ppb.

Relative humidity effects on the tubings are varied. Figures 12-15 show relative humidity effects on 61 m lengths of polyethylene, high density polyethylene, Bev-A-Line, and FEP at TLV UDMH. In most cases, increases in humidity had little effect on the response times to first indication or 50%. The 75% and 90% response times increased with increasing humidity for polyethylene and FEP. More erratic results were observed for high density polyethylene and Bev-A-Line. Bev-A-Line shows slightly longer response times with higher humidities to first indication and 50% of full scale. At 75% and 90%, there is an increase in response time from 0% RH to 40% RH, however, the average response times to 75 and 90% of full scale drop off at 85% RH. For Bev-A-Line, the response time to first indication remains stable throughout the humidity range tested. There is an increase in response times with increasing humidity to 50% and 75% of full scale. Bev-A-Line never attained 90% of full scale at 0% RH. There is a decrease in response time to 90% between 40% and 70% RH.

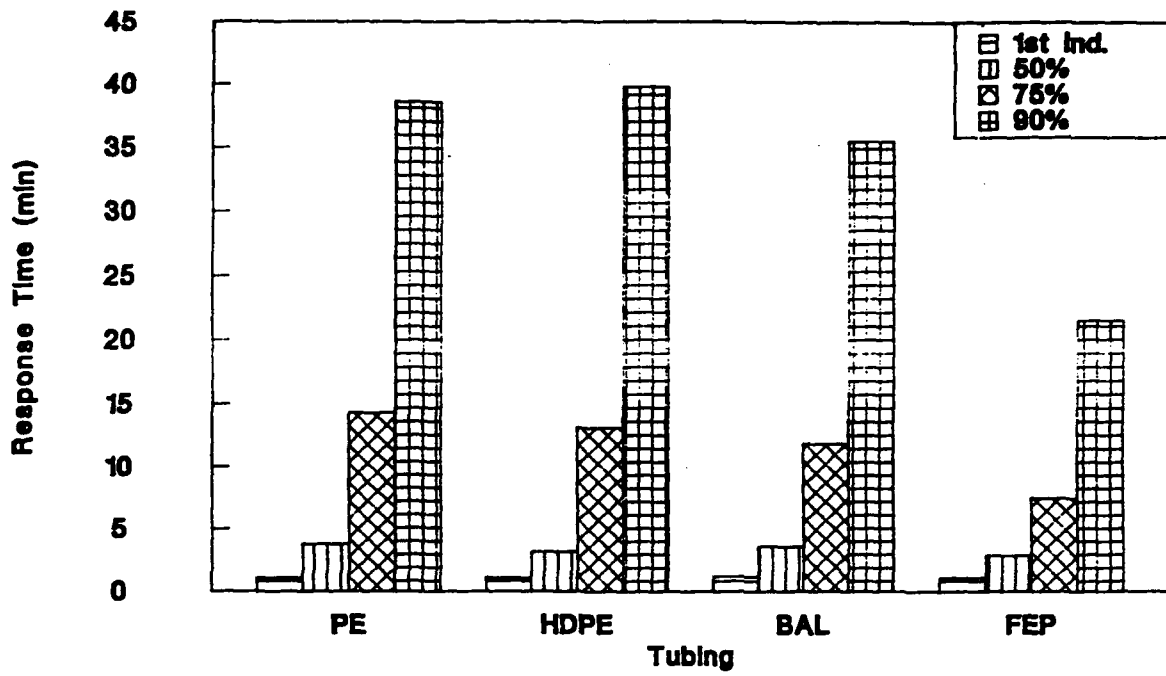

Figure 7. Response times of 61 m (200 ft) of tubing to TLV UDMH at 35% RH

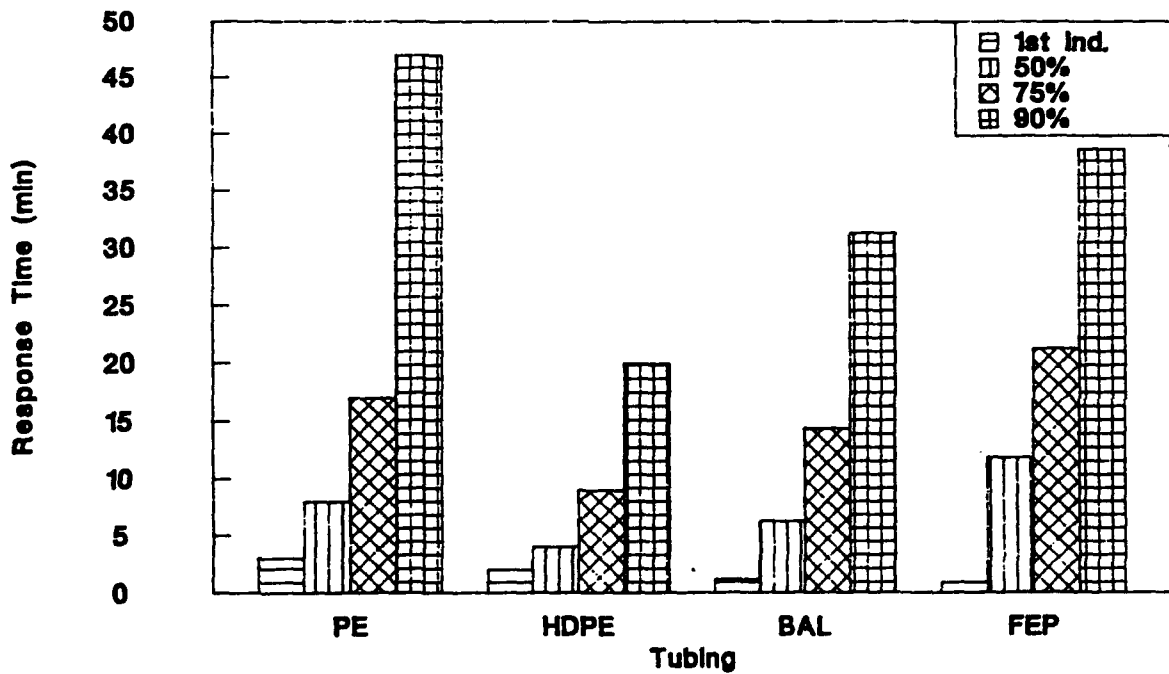

Figure 8. Response times of 61 m (200 ft) of tubing to TLV UDMH at 80% RH

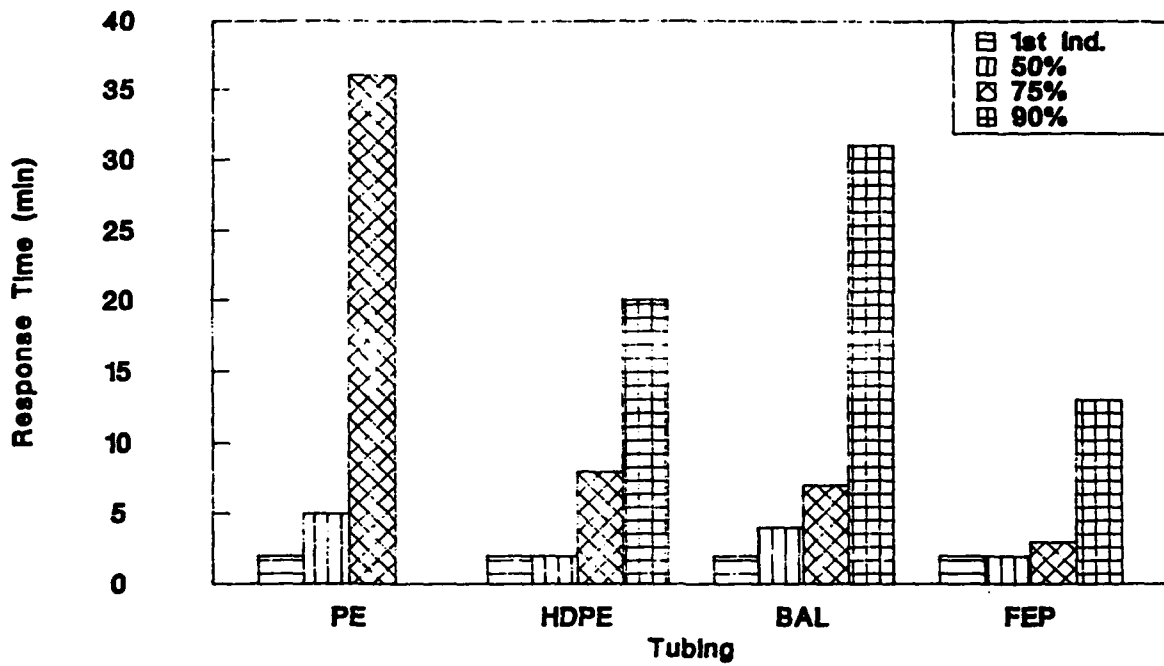

Figure 9. Response times of 61 m (200 ft) of tubing to 250 ppb UDMH at 0% RH

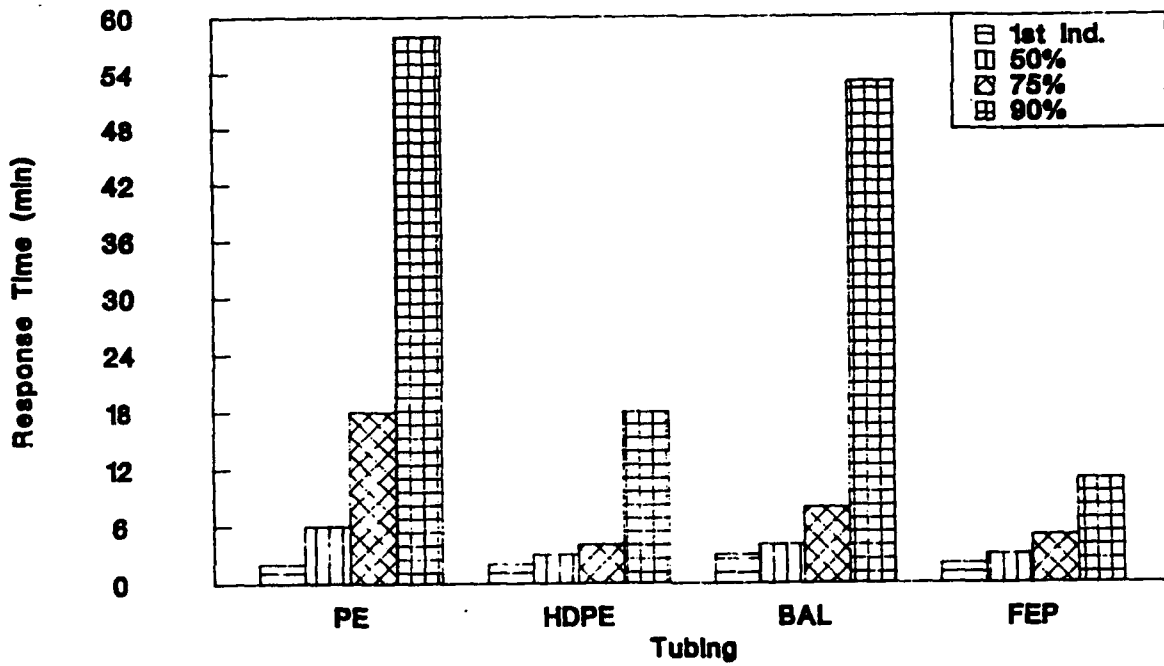

Figure 10. Response times of 61 m (200 ft) of tubing to 250 ppb UDMH at 45% RH

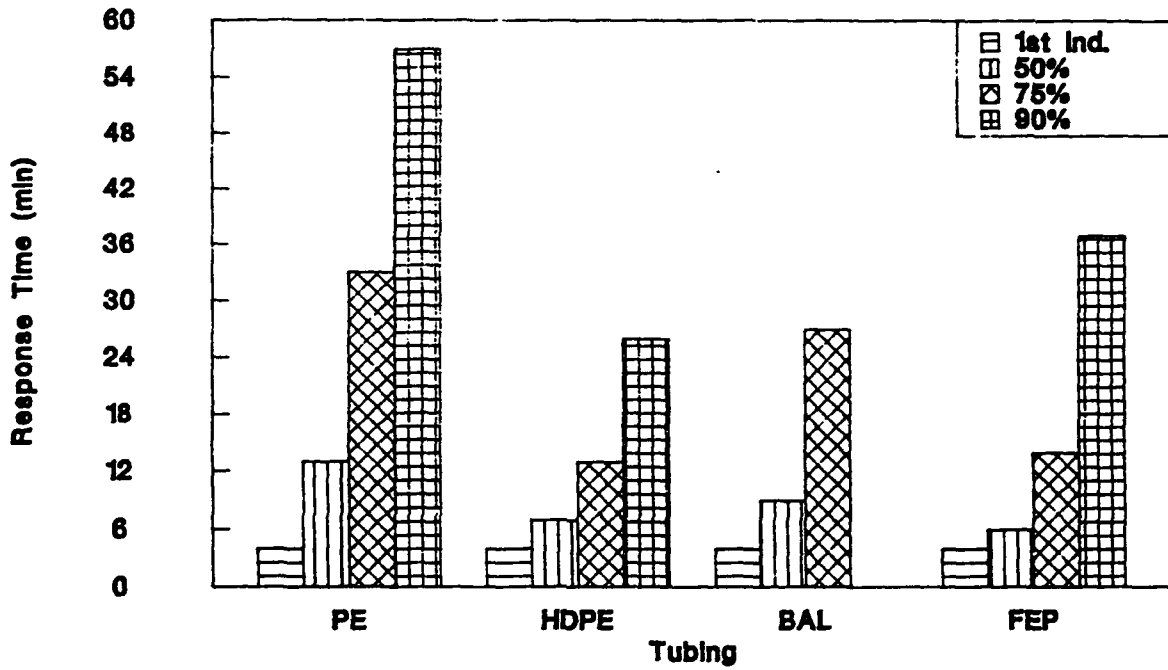

Figure 11. Response times of 61 m (200 ft) of tubing to 250 ppb UDMH at 85% RH

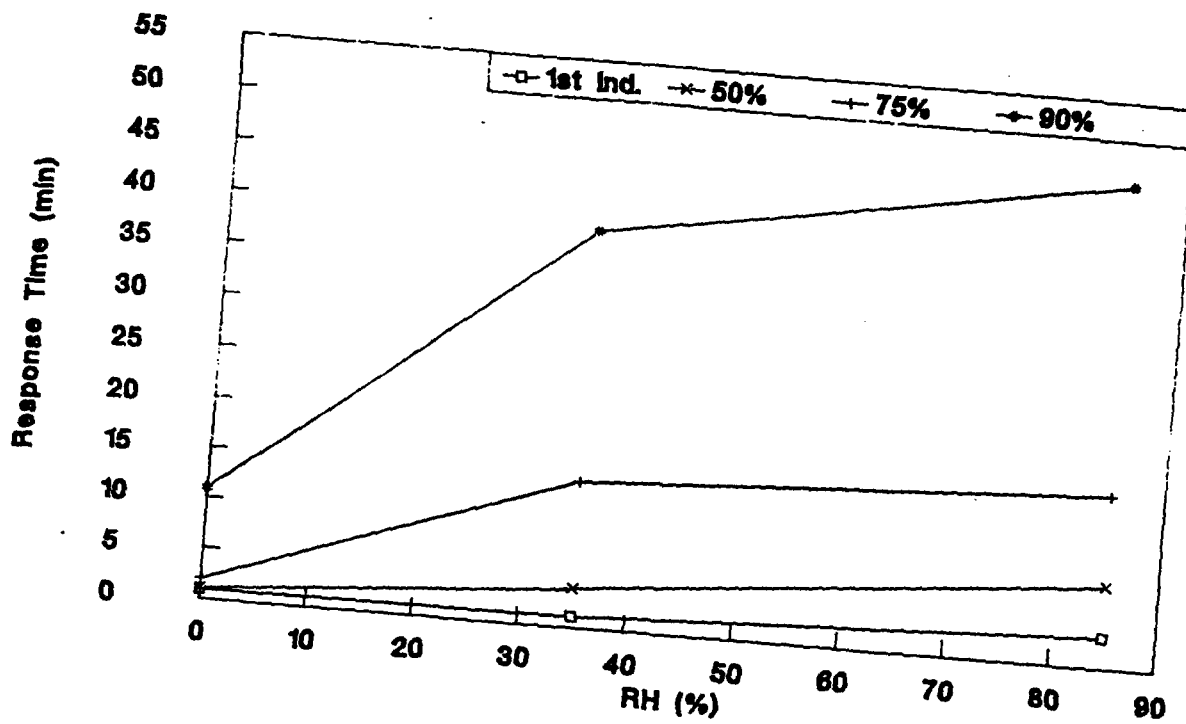

Figure 12. Relative humidity effect on 61 m (200 ft) of polyethylene exposed to TLV UDMH

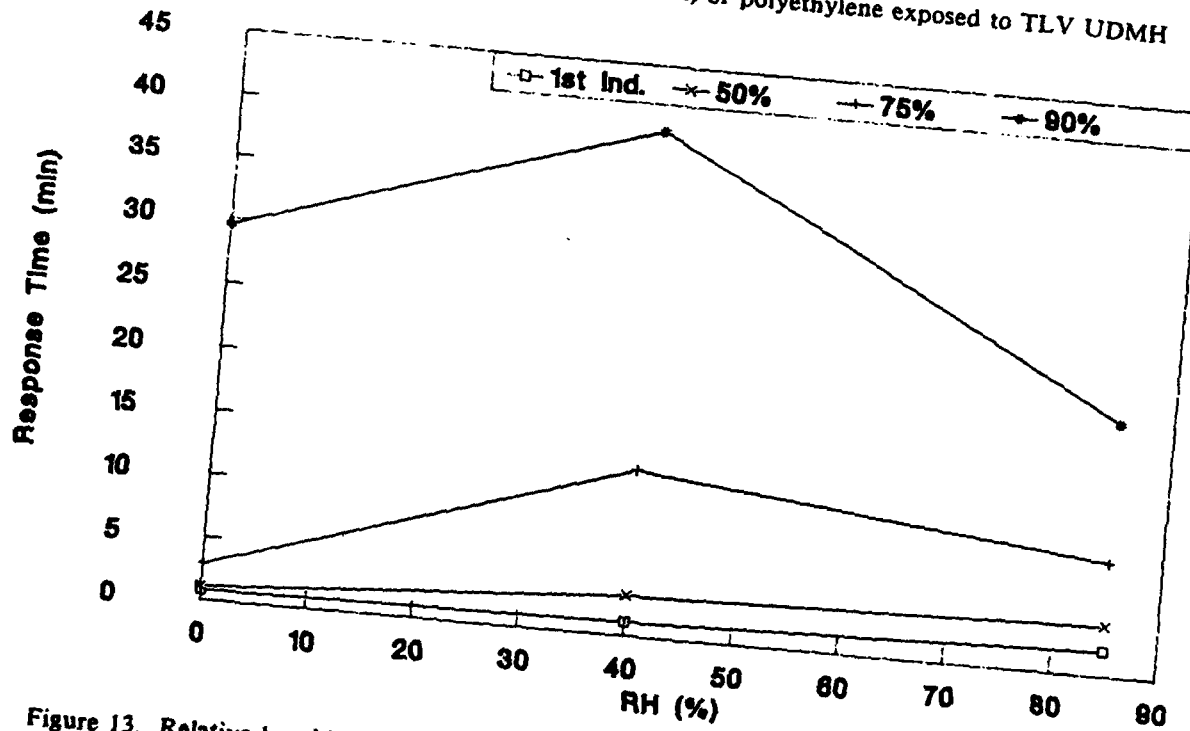

Figure 13. Relative humidity effects on 61 m (200 ft) of high density polyethylene exposed to TLV UDMH

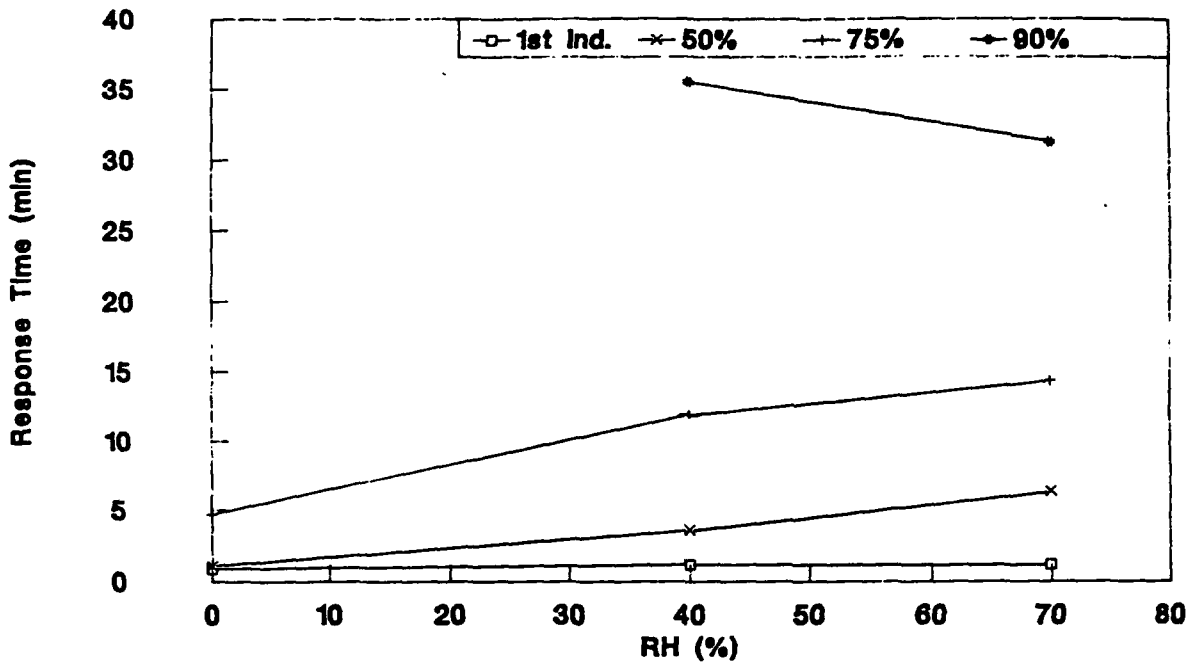

Figure 14. Relative humidity effects on 61 m (200 ft) of Bev-A-Line exposed to TLV UDMH

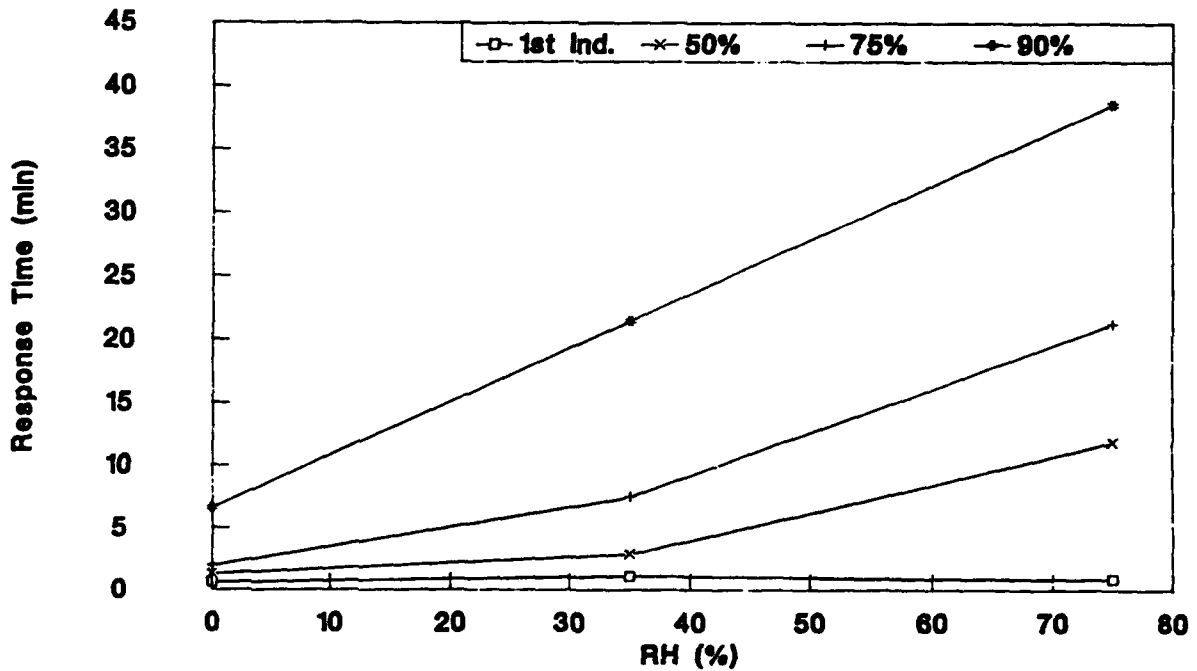

Figure 15. Relative humidity effects on 61 m (200 ft) of FEP exposed to TLV UDMH

Figures 16-19 show the humidity effect on tubing when exposed to 250 ppb of UDMH. In comparison with the responses to TLV levels of UDMH, the response times at high RH are increased from first indication to 90% of full scale for all tubings except FEP. As before, polyethylene shows a positive correlation between response time and RH at first indication and 50% of full scale. At 75% of full scale, however, polyethylene responds erratically to the various humidities tested. The tubing did not reach 90% of full scale at 0% RH. The response times remained stable between 45% and 85% RH. To first indication and 50% of full scale, high density polyethylene showed an increase in response times with an increase in RH as it had with TLV UDMH. For responses to 75% and 90% of full scale, high density polyethylene responded oppositely to its previous behavior at TLV UDMH. Bev-A-Line behaved similarly to its responses to TLV UDMH at first indication, 50%, and 75% of full scale. While Bev-A-Line never attained 90% of full scale at 0% RH with TLV UDMH, at 250 ppb it did not reach 90% of full scale at 87% RH. FEP demonstrates a positive correlation between response time and humidity to all but 90% of full scale. At 90% of full scale, the response times between 0% and 45% RH remained relatively stable, while they increased dramatically between 45% and 85% RH.

Hydrazine Exposures

Polyethylene, high density polyethylene, Bev-A-Line, and FEP were also tested with hydrazine. They were all exposed to approximately 100 ppb and 150 ppb of hydrazine. The results are shown in Figures 20 and 21. In Figure 20, all tubings except for polyethylene were exposed to hydrazine at 35% RH and analyzed with the Thermedics 141 (TECO) and the MDA 7100. The polyethylene was analyzed with the Thermedics analyzer. There is a significant difference between the response times of the HDPE taken with the TECO and the MDA 7100. With the TECO, the response times to first indication and 50% of FSD are very quick. The HDPE does not attain 75% or 90%. The response times of the Bev-A-Line are varied between the two analyzers. The Bev-A-Line did not achieve 90% when examined with the MDA 7100 as it did with the Thermedics analyzer. The FEP tubing performed similarly with both analyzers. In addition, FEP and high density polyethylene were exposed to 43 ppb and 185 ppb of hydrazine, respectively. Figures 22 and 23 detail the effect of hydrazine concentration on response time of FEP and high density polyethylene through all levels tested.

Comparisons can be made between tubing responses to TLV UDMH and TLV hydrazine at 35% RH. Polyethylene, Bev-A-Line, and FEP respond faster at first indication, 50%, 75%, and 90% of FSD when exposed to UDMH. High density polyethylene attains first indication and 50% faster when exposed to hydrazine, however, it did not reach 75% or 90%. When exposed to UDMH, high density polyethylene achieved both 75% and 90%. When comparing the response times to hydrazine of the high density polyethylene taken with the MDA 7100, and those taken with the TECO, the tubing gave quicker response times to UDMH at all levels.

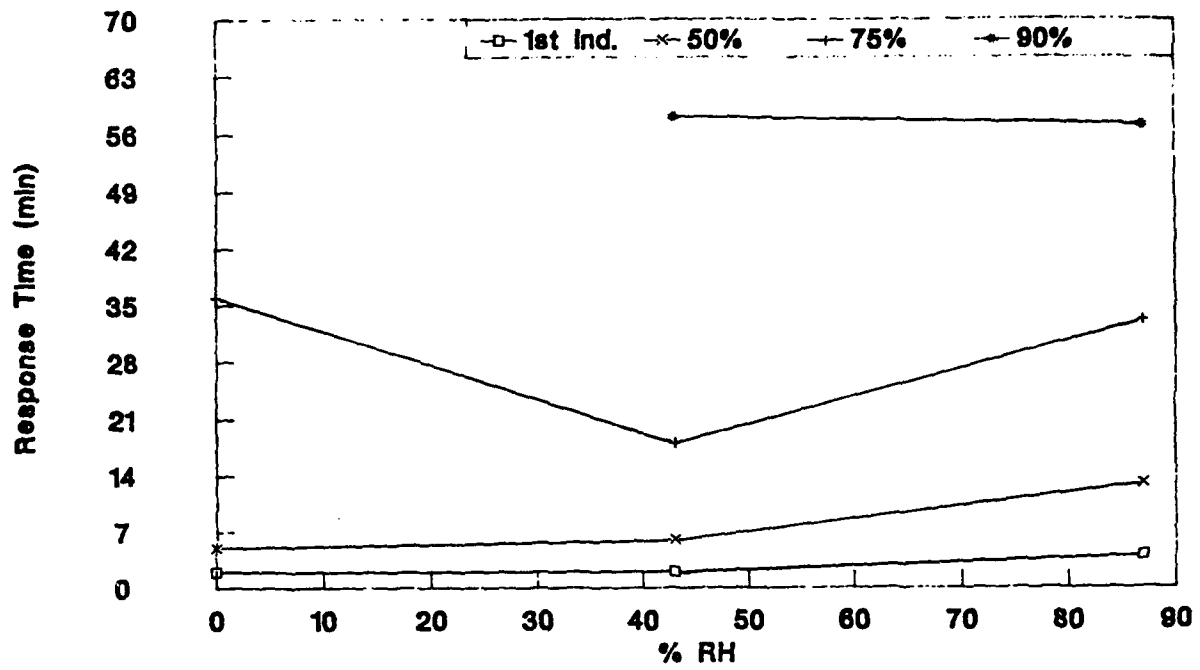

Figure 16. Relative humidity effects on 61 m (200 ft) of polyethylene exposed to 250 ppb UDMH

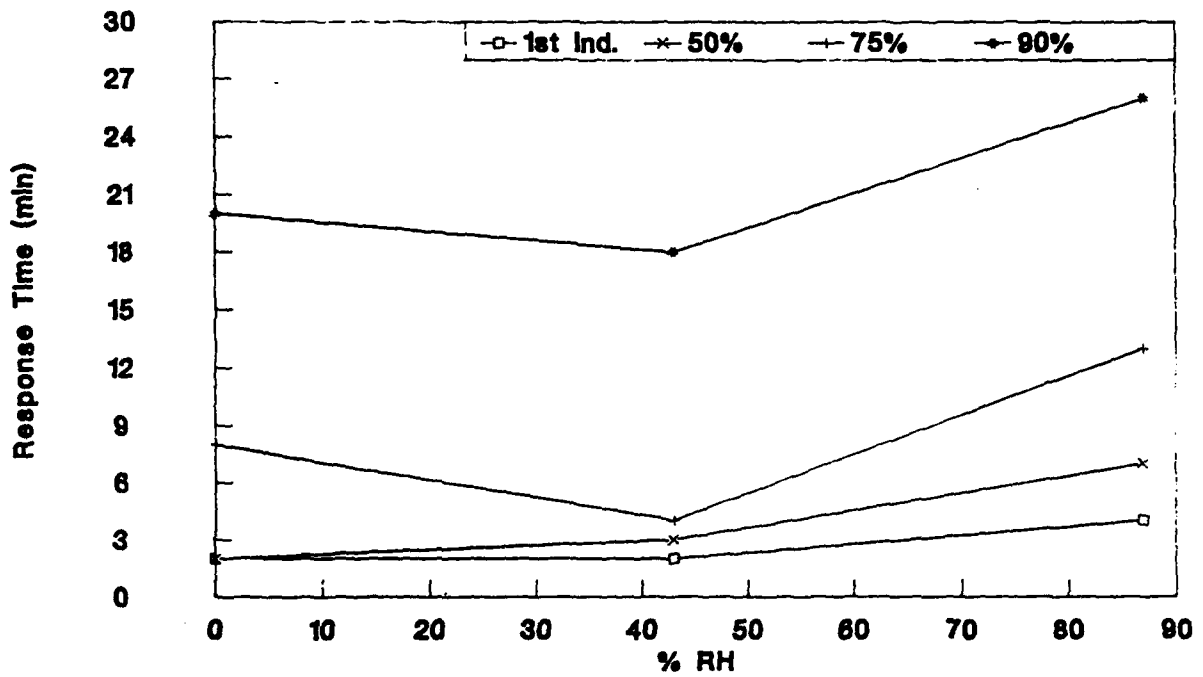

Figure 17. Relative humidity effects on 61 m (200 ft) of high density polyethylene exposed to 250 ppb UDMH

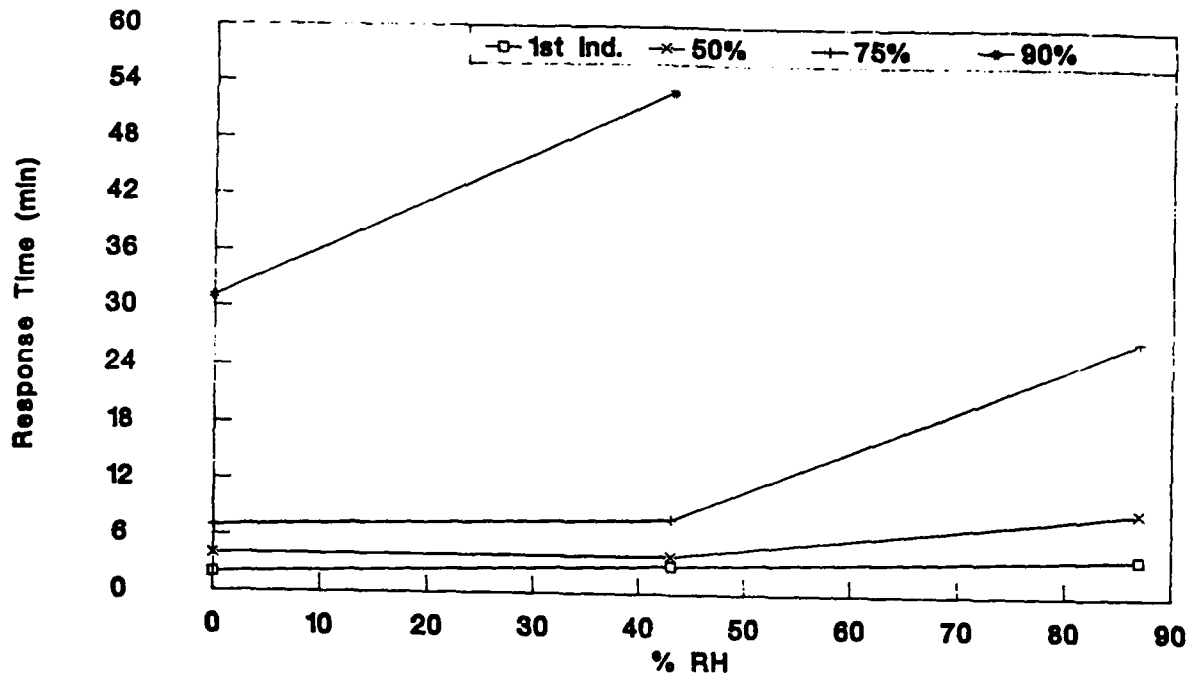

Figure 18. Relative humidity effects on 61 m (200 ft) of Bev-A-Line exposed to 250 ppb UDMH

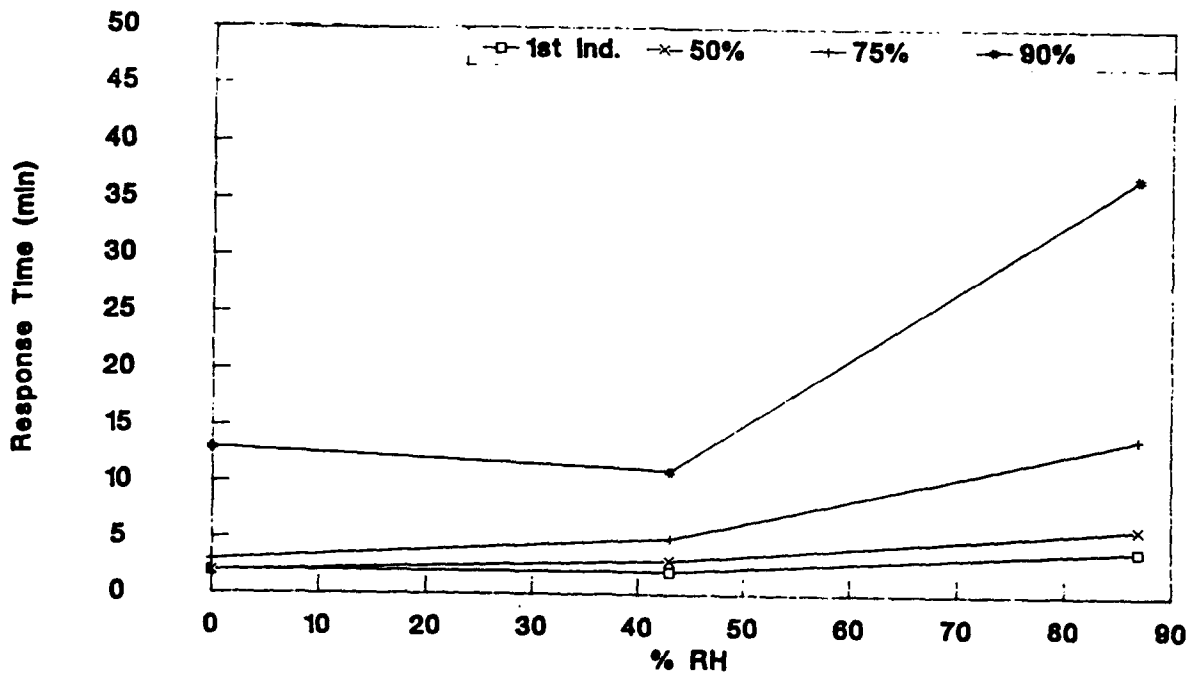
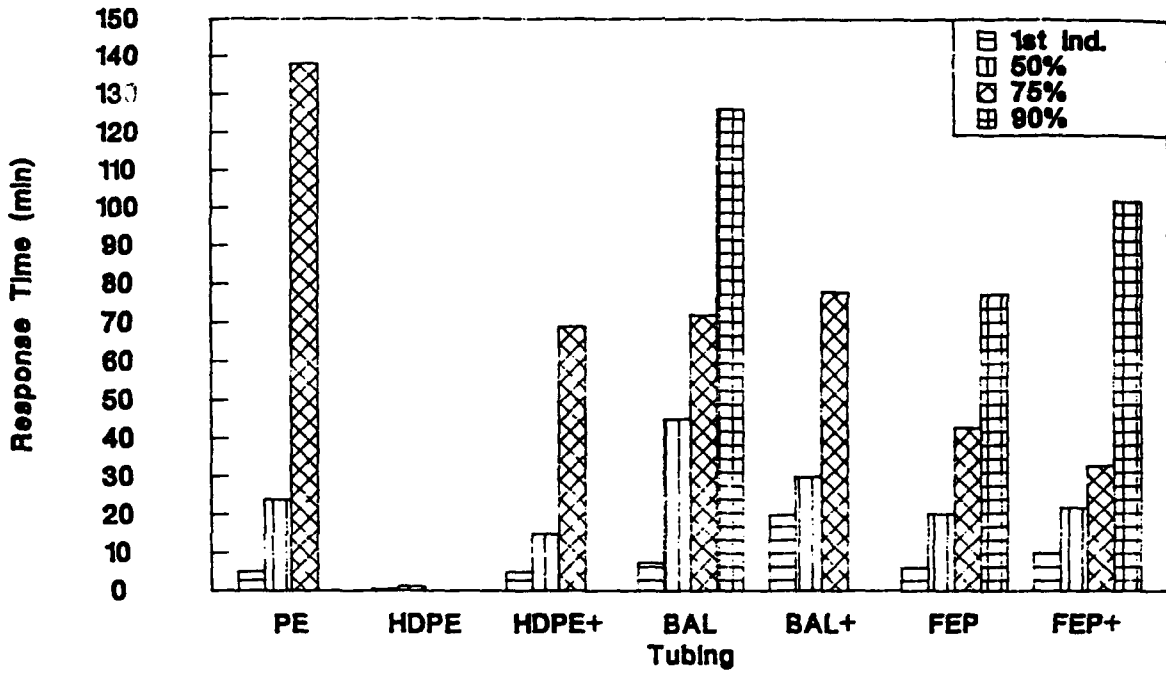

Figure 19. Relative humidity effects on 61 m (200 ft) of FEP exposed to 250 ppb UDMH



+ MDA 7100 Data

Figure 20. Response times of 61 m (200 ft) of tubing to 100 ppb hydrazine

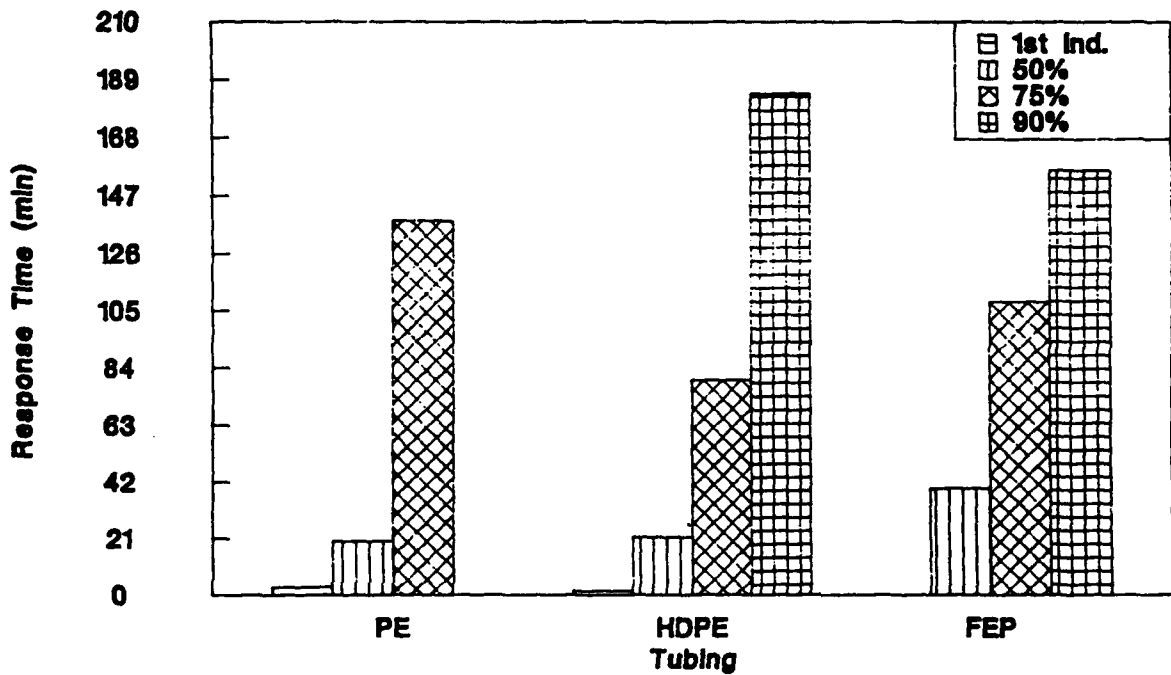

Figure 21. Response times of 61 m (200 ft) of tubing to 150 ppb hydrazine

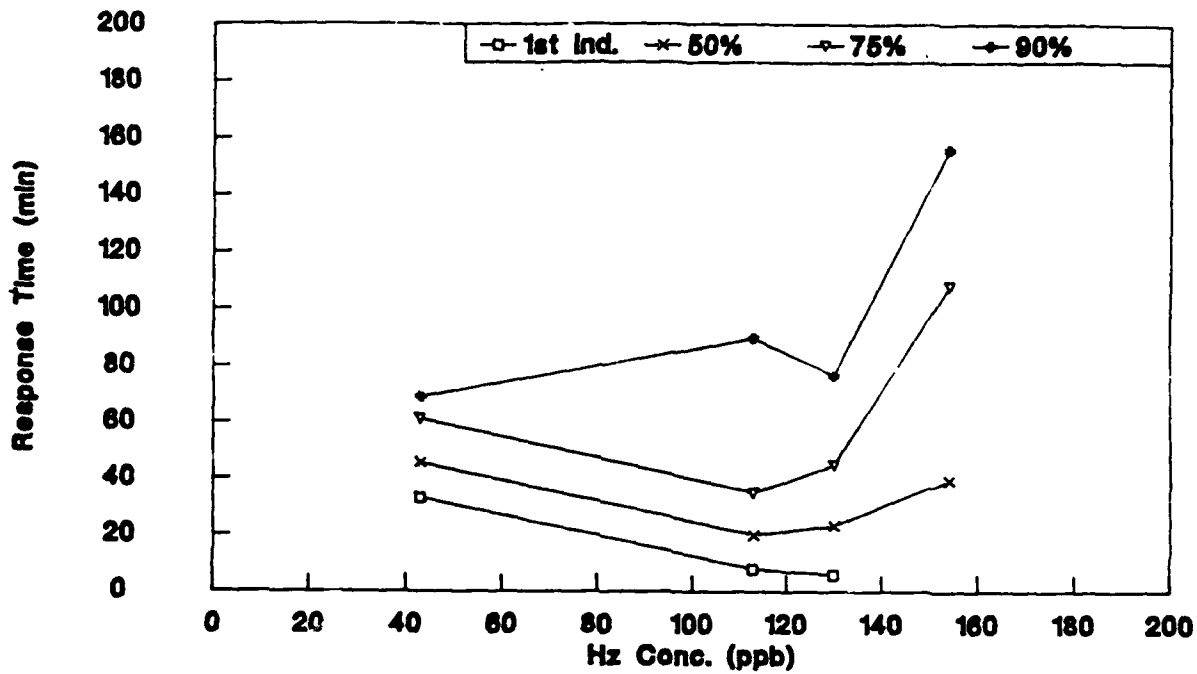

Figure 22. Effect of hydrazine concentration on 61 m (200 ft) of FEP tubing response time

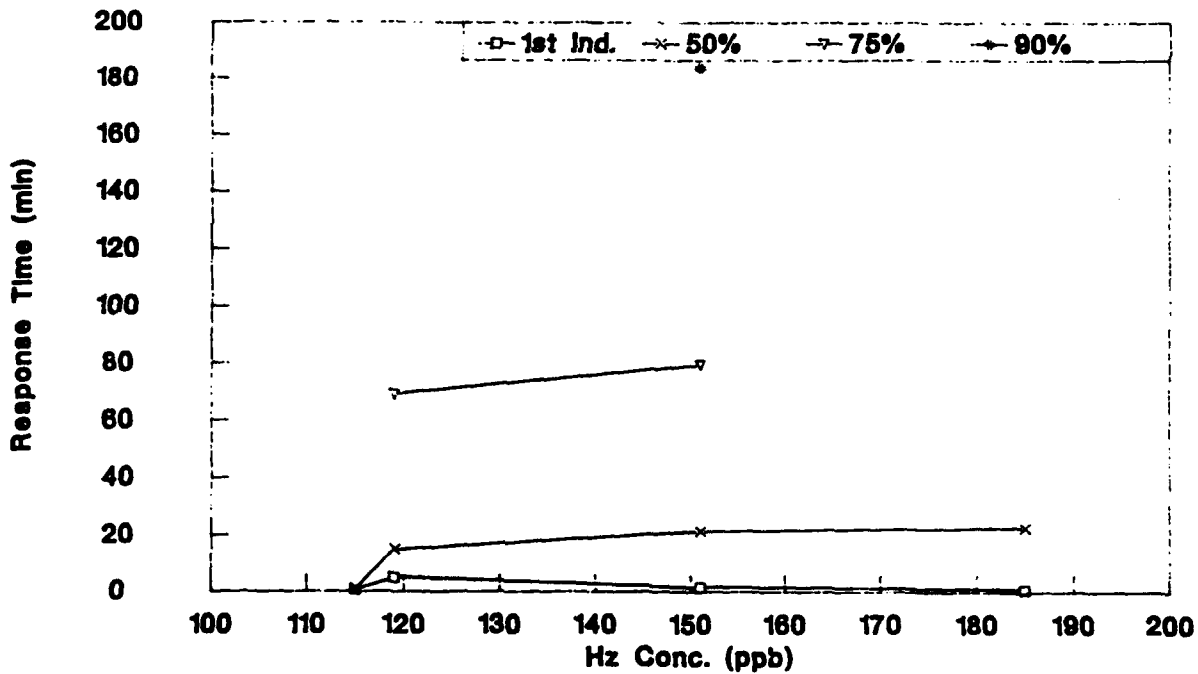

Figure 23. Effect of hydrazine concentration on 61 m (200 ft) of high density polyethylene tubing response time

Preconditioning of Tubing by Ambient Exposure

Sixty-one meter samples of the polyethylene, high density polyethylene, Bev-A-Line, and FEP tubing materials were conditioned with ambient air. This was accomplished by sampling outside air from a window on the fourth floor of the chemistry building at the Naval Research Laboratory. The sample coil and pump were sheltered, with the inlet of the tubing located in the stream of incoming ambient air. The tubings were continuously exposed for a period of one month during late summer. For two weeks, two tubings sampled air at a flow rate of 1 l/min, while the sampling rate of the other two tubings was 2 l/min. At the end of two weeks, the coils of tubing were switched. The tubings which were originally sampling air at a rate of 1 l/min were now sampling air at 2 l/min and vice versa. At the end of the month, the tubings had all sampled the same volume of air. Following the conditioning, the tubings were evaluated for transport efficiency. The tubings were exposed to TLV levels of UDMH at 35% RH and monitored. After extended conditioning with ambient air, samples showed a retardation in their ability to transport UDMH, as shown in Figure 24. FEP was affected to the greatest extent as compared with the average response times at TLV UDMH and 35% RH, requiring up to 13 times more time to reach first indication after preconditioning. The FEP did not attain 90% of full scale at all. Polyethylene required twice as much time to reach 75% and 90% of full scale, six times as long to the first indication, and three times as long to 50% of full scale. Other than the response times to first indication and 90% of full scale, high density polyethylene responded comparably to the average response time prior to preconditioning. After sampling ambient air for one month, the high density polyethylene tubing did not attain 90%. The Bev-A-Line was also affected by the preconditioning. The response times to first indication and 50% showed the greatest increase. After preconditioning, the Bev-A-Line required 4 times more time to reach the first indication, and 1.5 times as much time to attain both the 50% and 90% levels. There was no significant change in time required to reach 75%.

Effects of Cleaning Agents

Cleaning techniques were examined on the tubing exposed to ambient air for one month. After preconditioning of the tubing was complete and the tubings were exposed to UDMH, they were washed with methanol and reexposed to UDMH. In comparison with the response times to UDMH prior to ambient air exposure, FEP and Bev-A-Line responded slower to TLV levels of UDMH after ambient air exposure and subsequent UDMH exposure and methanol wash. High density polyethylene performed comparably after the ambient air exposure and methanol wash except to 90% of full scale, where twice as much time was required. Polyethylene gave quicker response times after ambient air conditioning and a methanol wash than prior to this. Exposure to UDMH and a methanol wash was repeated. The tubings were then exposed to UDMH and cleaned with 25 ppm of ammonia vapor in air. To obtain this gas concentration, a Matheson certified cylinder containing 509 ppm ammonia was diluted with clean air. The ammonia was blown through the contaminated tubing for one hour after exposure to UDMH. Exposure to UDMH and flushing with ammonia was repeated. Figures 25 and 26 show the comparisons between the ammonia and methanol wash. The polyethylene showed a greater decrease in response times after cleaning with ammonia as compared to methanol. The greatest improvements were at the 75% and 90% of full scale levels. The tubing achieved 90% of full scale in two out of three exposures.

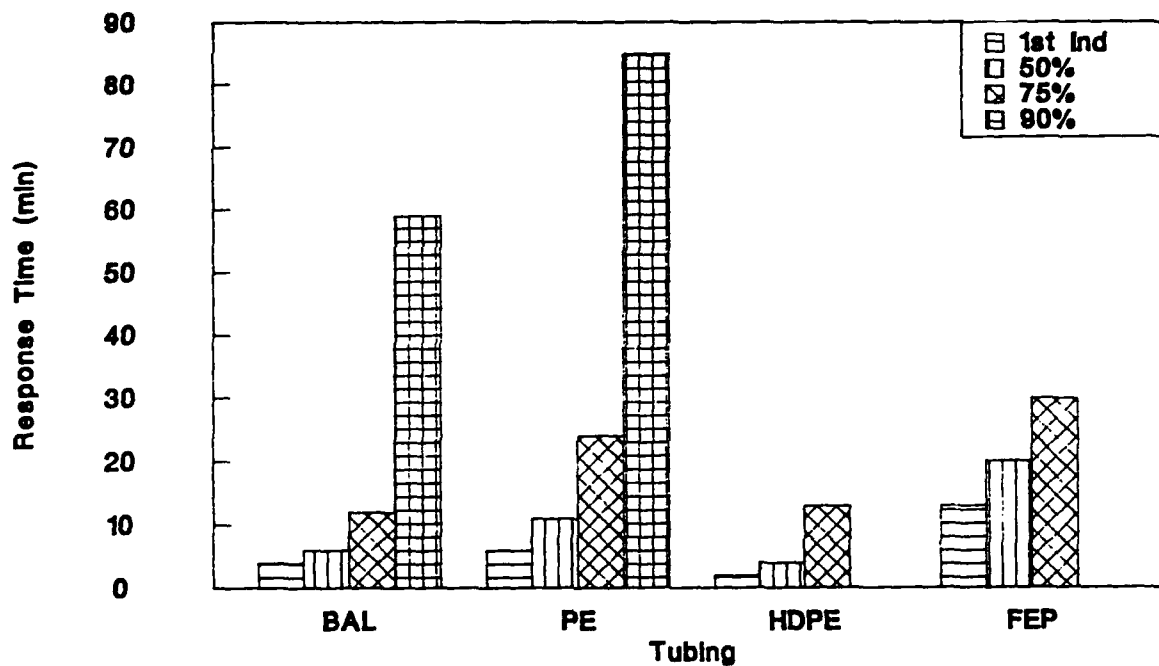

Figure 24. Response times to TLV UDMH of preconditioned tubings

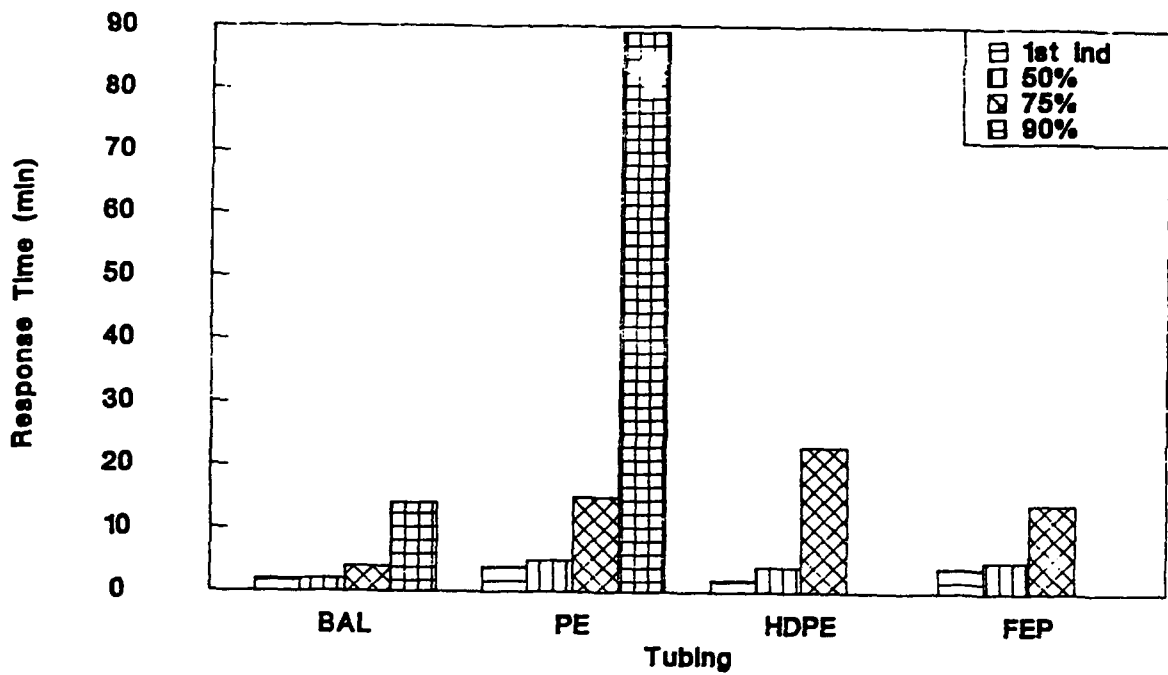

Figure 25. Response times to TLV UDMH of tubing cleaned with methanol

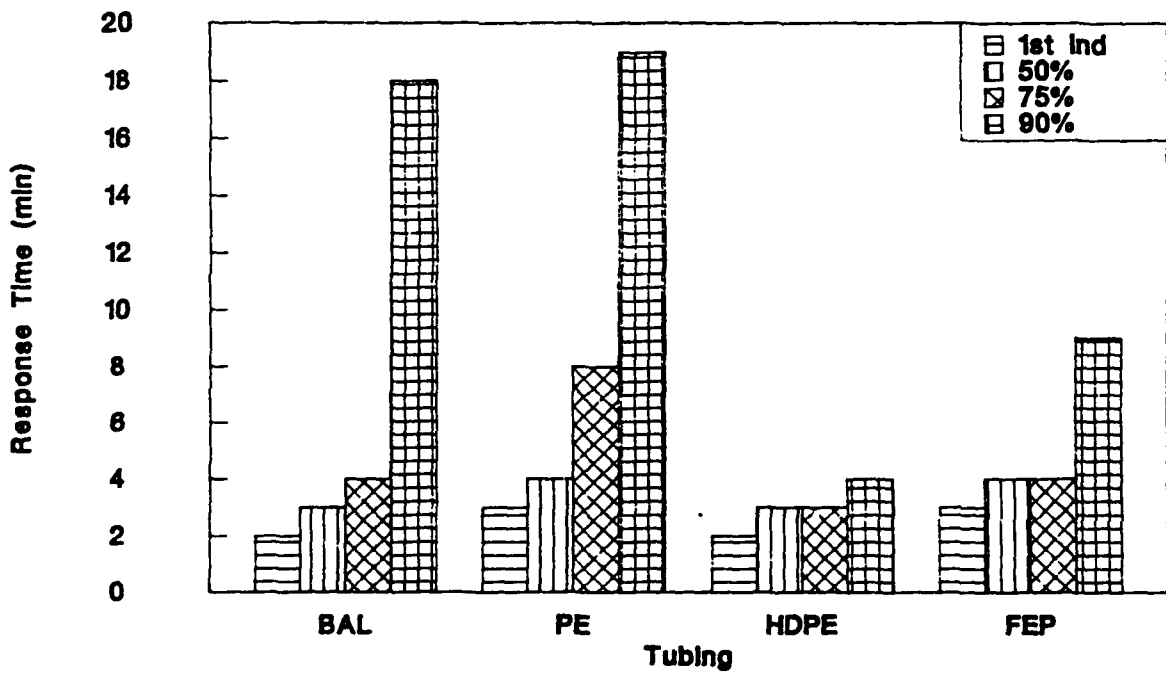

Figure 26. Response times to TLV UDMH of tubing cleaned with ammonia

In the one test where it did not reach 90%, the tubing had been purged with ammonia the day before the actual exposure to UDMH. The tubing was flushed with ammonia immediately prior to UDMH exposure for the other two tests. High density polyethylene responded quickly to the UDMH after flushing with ammonia vapor. After washing with methanol, the tubing did not reach 90% of full scale, however, it attained 90% within four minutes after cleaning with ammonia. Cleaning the Bev-A-Line tubing with ammonia or methanol did not make a significant difference in its subsequent performance. The FEP tubing performed significantly better after the ammonia cleaning procedure than it did after the methanol cleaning procedure at the 75% and 90% levels. The FEP attained 75% of full scale 3.5 times faster than after the methanol wash. It also reached 90% of full scale within 9 minutes, while it did not reach 90% at all after cleaning with methanol. There was not a significant increase in performance at the first indication and 50% levels.

CONCLUSIONS

The results of the vapor exposures are erratic. In some cases, the performance was good and consistent for all exposure replicates while in other cases, the response times varied between exposures. The variations observed cannot be correlated to any one parameter. The scatter in the results was probably due to a combination of the instruments used to analyze the vapor, the auxiliary pump, and the reactivity of the hydrazines. It is unclear why tubings which nominally have the same interior material, such as low and high density polyethylene, would behave differently. The results are erratic, but the high density polyethylene and FEP reach the maximum response level at both 500 ppb and 250 ppb for all the humidities tested. After preconditioning, all tubings showed retardation in their ability to transport UDMH. High density polyethylene was affected by the preconditioning the least. Only the tubing's response to the 90% level was hindered after exposure to ambient air.

Some basic considerations to be made when selecting a tubing material are: performance, length, flexibility, desired flow rate, cost, and whether location will allow access (for purposes of washing if needed). Many of the above mentioned candidates had transport times and percent vapor transported, which would be adequate for some applications.

Since most of the tests for the previous evaluation of tubing material with MMH were performed under different conditions than the exposures of tubing to UDMH and hydrazine, direct comparisons cannot be made. However, transport times of UDMH and MMH can be compared for the 23 m (75 ft) lengths of tubings tested, as the tests were run under identical conditions. In general, TLV levels of UDMH were transported down the tubings faster than MMH. For MMH, Bev-A-Line appeared to be the best overall tubing [3]. While Bev-A-Line is the most flexible, FEP and high density polyethylene generally performed better than the other tubings at longer lengths with UDMH. Increasing humidity had a similar effect on the tubing materials for both MMH and UDMH.

Use of cleaning agents must also be considered when choosing a tubing material. With the exception of Bev-A-Line, the tubings flushed with ammonia vapor gave better response times than

when cleaned with methanol. The polyethylene and high density polyethylene showed the greatest improvement. Bev-A-Line did not show a difference in performance depending on the cleaning agent used. The decrease in response times that occur after flushing the tubing with ammonia, may be due to the inability of the ammonia to thoroughly clean the tubing. The tubing may be preconditioned by the UDMH vapor to which it was previously exposed, allowing for quicker transport of UDMH vapor in subsequent exposures. The ammonia vapor may not be adequate to remove particulates that accumulate in tubing over time. Additional tests would be necessary to determine this, but a liquid wash seems a more reliable method. The choice of cleaning methods would also depend upon the actual installation and the ability to verify the tubing was dry after washing.

The Bev-A-Line exhibited the desired flexibility. High density polyethylene was the most difficult to work with in terms of flexibility. The decision of which material to use must be made on an individual use basis. The environment of the areas the tubing will transverse must be taken into account. A material that can withstand the conditions, for example, heating due to rocket exhaust, should be chosen.

REFERENCES

1. J.A.E. Hannum, *Recent Developments in the Toxicology of Propellant Hydrazines*, Chemical Propulsion Information Agency, CPTR 82-15, June 1982.
2. Committee on Toxicology, "Emergency and Continuous Exposure Guidance Levels for Selected Airborne Contaminants", Vol. 5, Board on Toxicology and Environmental Health Hazards, Commission on Life Sciences, National Research Council, National Academy Press, Washington, DC 1985.
3. ACGIH Report on Proposed and Current Changes to TLV and BEI Lists, 21 May 1989.
4. P.A. Taffe, S.L. Rose-Pehrsson, and J.R. Wyatt, *Material Compatibility with Threshold Limit Values of Monomethyl Hydrazine*, Naval Research Laboratory, Washington, D.C., NRL Memorandum Report 6291, October, 1988.
5. F.J. Waller, *Fluoropolymers*, Journal of Chemical Education, 1989, 66(6), 487.
6. Teflon is a trademark of E.I. du Pont de Nemours and Company.
7. E. C. Olson, Analytical Chemistry, 1960, 32(12), 1545.
8. J.R. Holtzclaw, S.L. Rose, and J.R. Wyatt, Analytical Chemistry, 1984, 56(14), 2952.

APPENDIX
Tubing Exposure Data

High Density Polyethylene Tubing Exposures

UDMH Exposures

Tubing Length (feet)	UDMH Conc (ppb)	RH (%)	Response Time (min)				Maximum Response (%)	Time to Reach Max % (min)	
			1st Ind	50%	75%	90%			
75	595	37		1.8	4.2	13.2	40.1	102	60
75	595	37		2.1	5.7	24.3	43.4	103	60
75	569	37		2.1	3.6	8.7	43.4	101	60
75	612	34		0.6	1.2	3.6	9.0	103	60
75	644	36		1.2	2.1	3.0	4.5	108	9.1
75	322	37		2.1	3.0	6.0	14.4	100	60
75	322	37		1.8	3.0	7.2	NA	96	60
75	307	38		2.4	3.6	10.2	NA	96	60
75	343	0		1.5	1.5	1.8	2.4	103	60
75	343	0		1.5	1.8	3.0	NA	85	60
75	337	0		0.9	1.2	1.2	2.1	85	60
75	523	0		<0.3	0.3	0.9	2.7	98	60
75	559	0		0.3	0.3	1.2	1.5	91	60
75	442	0		0.9	1.2	24.9	NA	92	60
200	516	0	0.9	1.5	5.4	48.2	NA	86	60
200	565	0	<0.6	0.6	1.5	NA	NA	79	60
200	591	0	0.6	1.2	1.8	10.8	23.4	105	60
200	547	38	1.2	3.3	12.3	37.7	114	100	114
200	563	37	0.9	3.0	13.8	41.9	102	105	102
*200	247	0	<2	2	4	29	NA	94	29
*200	212	0	2	3	15	NA	NA	97	83
*200	238	0	<2	2	4	11	NA	97	65
*200	238	47	2	3	4	18	95	100	95
*200	254	44	2	3	5	25	NA	95	28
*200	248	31	<2	2	4	10	81	100	81
*200	242	88	4	7	12	25	NA	97	120
*200	267	88	3	7	13	26	NA	99	95
*200	557	86	2	4	9	27	NA	96	81
*200	520	86	2	4	8	16	46	101	46
*200	497	86	2	5	9	18	NA	94	63

High Density Polyethylene Tubing Exposures

Hydrazine Exposures

Tubing Length (feet)	Hz Conc (ppb)	RH (%)	Response Time (min)					Maximum Response (%)	Time to Reach Max % (min)
			1st Ind	50%	75%	90%	100%		
200	185	40	0.9	22.8	NA	NA	NA	71	78
200	164	37	1.2	24.3	87	206	NA	90	206
200	137	37	1.8	18.6	72	162	NA	89	186
200	115	38	0.6	1.2	NA	NA	NA	59	108
*200	119	37	5	14	NA	NA	NA	70	84
*200	119	37	5	16	69	NA	NA	75	69

* MDA 7100 used.

Tubing Preconditioned with Ambient Air

Tubing Length (feet)	Cleaning Agent	UDMH Conc (ppb)	RH (%)	Response Time (min)					Maximum Response (%)	Time to Reach Max % (min)
				1st Ind	50%	75%	90%	100%		
200	NONE	530	37	2	4	13	NA	NA	87	85
200	MEOH	476	38	2	4	36	NA	NA	76	36
200	MEOH	509	34	2	3	10	NA	NA	88	102
200	NH3(1)	462	32	2	3	3	6	16	106	30
200	NH3(1)	439	35	1	2	3	3	3	111	17
200	NH3(1)	452	38	2	3	3	4	28	102	28

The MDA 7100 was used for all post ambient air exposures.

NH3(1): Tubing cleaned with ammonia immediately prior to UDMH exposure.

FEP Tubing Exposures

UDMH Exposures

Tubing Length (feet)	UDMH Conc (ppb)	RH (%)	Response Time (min)					Maximum Response (%)	Time to Reach Max % (min)
			1st Ind	50%	75%	90%	100%		
75	605	37		6.3	8.7	10.8	14.1	131	60
75	635	34		5.1	6.9	10.2	13.5	127	60
75	560	37		3.0	6.0	10.5	15.0	121	60
75	546	31	0.9	1.3	3.3	9.9	26.9	108	60
75	546	31	0.9	1.2	4.2	9.8	25.7	109	60
*75	530	0	1	2	2	2	NA	99	38
200	535	0		1.5	2.7	16.8	NA	92	60
200	535	0		1.2	1.8	4.5	NA	90	60
200	547	0	0.6	1.2	2.4	3.9	17.4	129	108
200	547	0	0.6	1.2	1.8	3.6	6.3	123	60
200	591	0	0.6	1.2	1.5	4.2	NA	99	60
200	584	36	0.9	2.7	7.2	19.8	46.7	106	90
200	549	38	1.2	3.0	7.8	23.1	53.0	106	108
200	460	73	0.9	12.9	22.2	36.5	72	105	108
200	463	72	0.9	10.8	20.4	40.7	84	106	84
*200	272	0	<2	2	3	19	40	102	40
*200	247	0	<3	3	4	9	44	102	66
*200	212	0	<2	2	3	12	NA	97	27
*200	238	47	2	4	6	NA	NA	88	19
*200	254	44	<2	2	4	13	NA	96	61
*200	238	31	2	3	4	9	64	104	70
*200	252	87	4	5	12	22	NA	99	140
*200	246	88	5	7	15	50	NA	96	100
*200	243	86	3	6	16	39	93	102	93

*MDA 7100 used.

FEP Tubing Exposures

Hydrazine Exposures

Tubing Length (feet)	Hz Conc (ppb)	RH (%)	Response Time (min)					Maximum Response (%)	Time to Reach Max % (min)
			1st Ind	50%	75%	90%	100%		
200	43	47	33.0	45.5	61.1	68.9	198	278	480
200	154	37	NA	39.5	108	156	162	100	162
200	130	37	6.0	23.3	44.9	76.8	106.2	105	138
200	110	38	6.3	17.1	40.7	78	NA	91	144
*200	119	37	8	18	35	NA	NA	80	50
*200	111	37	11	26	30	102	NA	91	84

* MDA 7100 used.

Tubing Preconditioned with Ambient Air

Tubing Length (feet)	Cleaning Agent	UDMH Conc (ppb)	RH (%)	Response Time (min)					Maximum Response (%)	Time to Reach Max (min)
				1st Ind	50%	75%	90%	100%		
200	NONE	416	41	13	20	30	NA	NA	81	49
200	MEOH	572	35	4	5	22	NA	NA	85	108
200	MEOH	427	35	3	4	5	8	NA	78	97
200	NH3	475	36	4	4	5	10	59	103	59
200	NH3(I)	475	36	2	3	3	8	42	103	65

The MDA 7100 was used for all post ambient air exposures.

NH3: Tubing cleaned with ammonia day prior to UDMH exposure.

NH3(I): Tubing cleaned with ammonia immediately prior to exposure.

8ev-A-Line Tubing Exposures

UDMH Exposures

Tubing Length (feet)	UDMH Conc (ppb)	RH (%)	Response Time (min)					Maximum Response (%)	Time to Reach Max % (min)
			1st Ind	50%	75%	90%	100%		
75	563	34		1.5	3.9	9.3	31.1	101	60
75	572	35		1.2	2.1	10.8	45.2	102	60
75	550	35		0.6	2.4	18	60.0	100	60
75	620	36		1.5	1.8	2.4	4.8	101	9.3
75	638	34		0.9	1.2	1.8	3.9	103	19
75	638	34		1.2	1.5	2.4	3.6	102	4.5
75	333	38		2.1	6.0	19.8	NA	97	60
75	333	38		2.4	3.9	14.7	NA	98	60
75	324	37		1.8	2.4	4.7	9.6	96	60
75	517	0		0.9	1.2	1.8	6.6	101	13.6
75	517	0		1.2	1.8	NA	NA	83	6
75	549	0		1.2	1.2	1.2	2.1	114	4.8
75	581	0		0.6	1.2	3.3	6.9	101	7.8
75	581	0		0.6	2.1	6.6	NA	93	60
75	531	0		0.6	.3	3.0	8.4	100	8.4
200	522	0	1.8	2.4	6.0	NA	NA	81	60
200	581	0	0.6	0.6	2.4	NA	NA	89	60
200	569	0	0.2	0.2	5.7	NA	NA	86	60
200	561	40	1.2	3.6	12.6	38.9	NA	99	120
200	544	38	1.2	3.6	11.1	32.0	95.8	103	114
200	493	72	1.2	5.4	16.8	36.2	120	100	120
200	449	72	1.2	7.2	12.0	26.3	72	110	96
*200	238	0	3	4	6	27	NA	90	27
*200	260	0	2	3	6	35	NA	100	43
*200	236	0	2	4	10	NA	NA	88	52
*200	276	44	2	4	7	40	NA	96	55
*200	233	44	3	4	8	66	NA	92	66
*200	212	86	4	8	32	NA	NA	87	70
*200	227	86	4	9	21	NA	NA	86	63

* MDA 7100 used.

Bev-A-Line Tubing Exposures

Hydrazine Exposures

Tubing Length (feet)	Hz Conc (ppb)	RH (%)	Response Time (min)					Maximum Response (%)	Time to Reach Max % (min)
			1st Ind	50%	75%	90%	100%		
200	116	37	9.0	47.9	72	126	NA	94	144
200	118	36	5.7	42.2	72	NA	NA	71	72
*200	120	37	24	33	198	NA	NA	75	96
*200	108	38	16	23	60	NA	NA	78	108
*200	126	38	20	33	NA	NA	NA	69	105

* MDA 7100 used.

Tubing Preconditioned with Ambient Air

Tubing Length (feet)	Cleaning Agent	UDMH Conc (ppb)	RH (%)	Response Time (min)					Maximum Response (%)	Time to Reach Max % (min)
				1st Ind	50%	75%	90%	100%		
200	NONE	530	37	4	6	12	59	106	105	108
200	MEOH	462	32	2	2	5	20	NA	98	62
200	MEOH	509	34	2	2	3	8	51	100	42
200	NH3(1)	452	38	2	3	3	30	102	94	51
200	NH3(1)	544	36	3	4	5	12	42	104	57
200	NH3	439	35	2	3	4	12	NA	103	114

The MDA 7100 was used for all post ambient air exposures.

NH3(1): Tubing cleaned with ammonia immediately prior to UDMH exposure.

NH3: Tubing cleaned with ammonia day prior to UDMH exposure.

Polyethylene Tubing Exposures

UDMH Exposures

Tubing Length (feet)	UDMH Conc (ppb)	RH (%)	Response Time (min)					Maximum Response (%)	Time to Reach Max % (min)
			1st Ind	50%	75%	90%	100%		
75	560	34		1.2	2.4	4.5	37.1	104	58
75	612	34		1.2	2.1	4.2	15.9	100	60
75	616	35		1.2	1.5	3.6	NA	94	60
75	616	35		0.9	2.1	4.2	NA	95	60
75	621	35		0.9	1.5	3.0	NA	97	6.3
75	625	35		1.2	1.8	2.7	8.4	100	8.4
75	621	34		0.6	1.5	2.1	7.5	101	9.9
75	339	39		1.5	2.4	3.9	34.4	101	60
75	339	39		1.5	2.4	2.4	2.7	128	60
75	334	36		2.1	3.3	6.9	NA	98	60
75	341	39		2.4	4.8	14.1	NA	95	60
75	496	0		0.6	2.1	6.6	NA	89	60
75	538	0		<0.9	0.9	1.8	4.5	100	60
75	538	0		0.6	0.9	2.1	NA	90	60
200	618	0	<0.6	0.6	0.9	1.5	1.8	121	60
200	598	0	0.6	1.2	3.0	21.0	NA	93	60
200	598	0	1.2	1.5	1.8	10.2	NA	95	60
200	524	0	<1.2	1.2	2.4	NA	NA	83	105
200	638	37	1.2	4.5	16.5	38.9	NA	94	60
200	710	36	0.9	3.0	12.0	38.3	NA	100	150

TECO experiencing major problems; MDA 7100 to be used for remainder of testing.

200	236	0	2	4	16	NA	NA	85	47
200	280	0	2	7	70	NA	NA	78	70
200	218	0	2	5	22	NA	NA	84	116
200	276	44	3	7	23	NA	NA	89	78
200	239	42	2	4	13	58	NA	96	76
200	233	44	2	6	18	NA	NA	87	113
200	280	88	4	9	28	57	NA	90	57
200	262	86	5	15	38	NA	NA	89	108
200	238	86	3	14	34	NA	NA	88	102
200	540	86	2	7	19	48	NA	96	133
200	550	86	3	8	15	45	NA	96	132

Polyethylene Tubing Exposures

Hydrazine Exposures

Tubing Length (feet)	Hz Conc (ppb)	RH (%)	Response Time (min)					Maximum Response (%)	Time to Reach Max % (min)
			1st Ind	50%	75%	90%	100%		
200	124	35	7.5	22.5	NA	NA	NA	55	59
200	109	37	5.7	31.6	NA	NA	NA	63	63
200	172	37	3.3	20.3	288	NA	NA	79	147
200	124	37	5	16	138	NA	NA	52	129

Tubing Preconditioned with Ambient Air

Tubing Length (feet)	Cleaning Agent	UDMH Conc (ppb)	RH (%)	Response Time (min)					Maximum Response (%)	Time to Reach Max % (min)
				1st Ind	50%	75%	90%	100%		
200	NONE	544	36	6	11	24	85	NA	92	85
200	MEOH	416	41	5	7	21	111	NA	95	126
200	MEOH	427	35	2	4	8	66	NA	96	66
200	NH3	529	36	3	5	14	NA	NA	86	37
200	NH3(1)	451	36	3	4	6	19			

NH3: Tubing cleaned with ammonia day prior to UDMH exposure.

NH3(1): Tubing cleaned with ammonia immediately prior to UDMH exposure.

PFA Tubing Exposures

Tubing Length (feet)	UDMH Conc (ppb)	RH (%)	Response Time (min)				Maximum Response (%)	Time to Reach Max % (min)
			50%	75%	90%	100%		
75	608	34	3.3	6.6	12.6	33.5	105	60
75	595	36	6.0	10.2	15.3	22.5	120	60
75	595	36	2.1	5.4	12.3	22.5	117	60
75	550	34	1.2	3.0	7.2	*	108	60

* TECO experiencing problems.

TFE Tubing Exposures

Tubing Length (feet)	UDMH Conc (ppb)	RH (%)	Response Time (min)				Maximum Response (%)	Time to Reach Max % (min)
			50%	75%	90%	100%		
74	644	36	0.9	2.1	3.3	NA	90	6.0
74	595	37	<0.6	0.6	1.2	1.8	109	3.0
74	595	37	1.2	1.8	6.9	NA	76	3.9
74	628	36	0.9	1.5	1.8	3.0	103	5.4
74	621	34	1.2	1.5	2.4	3.6	103	7.4
74	639	37	0.9	1.8	3.0	NA	98	60
74	639	34	0.9	1.2	1.8	3.3	104	6.9
74	324	36	2.4	4.2	12.0	NA	99	60
74	324	36	2.7	3.9	8.4	23.7	104	60
74	329	39	2.7	4.5	16.2	NA	97	60
74	506	0	0.6	1.2	26.9	NA	99	60
74	506	0	0.6	0.6	1.8	NA	87	60
74	500	0	0.3	0.9	6.6	NA	91	60

Polypropylene Tubing Exposures

Tubing Length (feet)	UDMH Conc. (ppb)	RH (%)	Response Time (min)				Maximum Response (%)	Time to Reach Max % (min)
			50%	75%	90%	100%		
75	958	37	<0.9	0.9	1.5	3.3	101	60
75	958	37	0.6	1.2	1.5	NA	92	60
75	620	36	0.6	0.9	1.5	4.8	102	6.9
75	326	39	1.8	9.0	NA	NA	84	60
75	326	38	1.8	3.0	7.2	17.7	104	60
75	358	38	1.8	6.0	16.2	50.9	100	60
75	506	0	<0.3	0.3	2.4	NA	81	60
75	522	0	<0.3	<0.3	0.3	0.6	97	60
75	535	0	0.6	0.9	3.0	NA	94	60
75	535	0	0.9	2.7	NA	NA	88	18.9
75	524	24	0.9	1.5	3.0	NA	99	60
100	569	35	0.6	0.9	2.4	NA	99	60
100	569	22	0.3	0.9	2.1	NA	94	46

Bev-A-Line 1/2

Tubing Length (feet)	UDMH Conc. (ppb)	RH (%)	Response Time (min)				Maximum Response (%)	Time to Reach Max % (min)
			50%	75%	90%	100%		
75	329	39	2.4	3.3	6.0	NA	92	60
75	329	39	3.0	4.2	10.8	NA	93	60
75	312	42	2.1	3.3	6.0	NA	97	60
75	528	0	0.9	1.2	1.2	1.5	107	9.6
75	528	0	0.9	1.2	1.8	7.5	98	7.5
75	535	0	<0.9	<0.9	<0.9	0.9	105	60
75	506	0	<0.3	<0.3	0.3	1.2	106	60
75	518	0	0.6	0.9	2.1	18	97	60
75	518	0	1.2	1.5	4.2	NA	104	60
75	442	0	0.3	0.6	1.8	NA	89	60