

Netherlands
organization for
applied scientific
research



TNO Physics and Electronics
Laboratory



DTIC FILE COPY

90-1230

AD-A225 064



DTIC
ELECTE
AUG 07 1990
S E D

DISTRIBUTION STATEMENT A
Approved for public release;
Distribution Unlimited

Netherlands
organization for
applied scientific
research



TNO Physics and Electronics
Laboratory



P.O. Box 96864
2509 JG The Hague
Oude Waalsdorperweg 63
The Hague, The Netherlands
Fax +31 70 328 09 61
Phone +31 70 326 42 21

TNO-report

report no.
FEL-90-B114

copy no.

8

title

Feasibility study of a non-reciprocal
latched ferrite phase shifter in the
92-96 GHz frequency band

Nothing from this issue may be reproduced
and/or published by print, photoprint,
microfilm or any other means without
previous written consent from TNO.
Submitting the report for inspection to
parties directly interested is permitted.

In case this report was drafted under
instruction, the rights and obligations
of contracting parties are subject to either
the 'Standard Conditions for Research
Instructions given to TNO' or the relevant
agreement concluded between the contracting
parties on account of the research object
involved.

TNO

author(s):

F.A. Nennie

classification

title : unclassified
abstract : unclassified
report : unclassified

no. of copies : 18

no. of pages : 14

appendices : -

date : April 1990

All information which is classified according
to Dutch regulations shall be treated by the
recipient in the same way as classified
information of corresponding value in his own
country. No part of this information will be
disclosed to any party.

Accession For	
NTIS GRA&I	<input checked="" type="checkbox"/>
DTIC TAB	<input type="checkbox"/>
Unannounced	<input type="checkbox"/>
Justification	
By	
Distribution/	
Availability Codes	
Avail and/or	
Dist	Special
A-1	

DISTRIBUTION STATEMENT A
Approved for public release;
Distribution Unlimited

DTIC
ELECTE
AUG 07 1990
S E D



report no. : FEL-90-B114
title : Feasibility study of a non-reciprocal latched ferrite
phase shifter in the 92-96 GHz band

author(s) : F.A. Nennie
institute : TNO Physics and Electronics Laboratory

date : April 1990
NDRO no. :
no. in pow '90 : 710.5

ABSTRACT (UNCLASSIFIED)

A non-reciprocal latched lithium ferrite phase shifter has been developed at 92-96 GHz.

A cylindrical lithium ferrite rod with a diameter of 1.27 mm and an axial hole of 0.25 mm was placed in the middle of a standard waveguide. Because of mechanical uncertainties we chose for a ferrite length of 10.0 mm.

The average saturation differential phase shift at 92-96 GHz is 92.5 degrees.

Over a 4 GHz frequency band the saturation differential phase shift is almost independent of frequency.

The insertion loss of 1.5-2.5 dB can be improved.

The rise time of the 90% saturation pulse is 100 nsec, the pulse length is 650 nsec and the fall time is 950 nsec.

rapport no. : FEL-90-B114
titel : Studie betreffende de realiseerbaarheid van een niet
reciproke schakelbare ferriet fasedraaier in de
92-96 GHz frequentieband.

auteur(s) : F.A. Nennie
instituut : Fysisch en Elektronisch Laboratorium TNO

datum : april 1990
hdo-opdr.no. :
no. in iwp '90 : 710.5

SAMENVATTING (ONGERUBRICEERD)

Een niet reciproke schakelbare lithium ferriet fasedraaier is ontworpen in de frequentieband van 92-96 GHz.

Een circulair lithium ferrietstaafje met een diameter van 1.27 mm en een axiaal gat van 0.25 mm werd in het midden van een standaard golfpijp geplaatst. Wegens mechanische onzekerheden hebben we gekozen voor een ferrietlengte van 10.0 mm.

De gemiddelde differentiële verzadigingsfaseverschuiving op 92-96 GHz is 92.5 graden.

De differentiële verzadigingsfaseverschuiving is over een 4 GHz frequentieband vrijwel onafhankelijk van de frequentie.

De tussenschakeldemping van 1.5-2.5 dB kan verbeterd worden.

De stijgtijd van de 90% verzadigingspuls is 100 nsec, de pulslengte is 650 nsec en de afvaltijd is 950 nsec.

ABSTRACT	1
SAMENVATTING	2
CONTENTS	3
1 INTRODUCTION	4
2 PHASE SHIFTER DESIGN	6
3 GENERAL FERRITE PROPERTIES	8
4 EXPERIMENTAL RESULTS	9
5 DISCUSSION AND CONCLUSION	12
6 ACKNOWLEDGEMENT	13
REFERENCES	14

1 INTRODUCTION

The experimental results presented in this report are an extension of the previous work at 52 and 66 GHz [1], that led to the design and production of a ferrite phase shifter which has been tested in Germany at FGAN.

Figure 1 shows the 92-96 GHz phase shifter. The desired phase shift is achieved by tangentially magnetizing the ferrite rod. The switching wire is led through an axial concentric hole.

A lithium ferrite rod with a diameter of 1.27 mm and a length of 10 mm has been used.

The inside dimensions of the waveguide are the standard waveguide (WR-10) dimensions (1.27 mm high and 2.54 mm wide).

A single step $\lambda/4$ wavelength dielectric matching transformer has been used.

The ferrite is magnetized with the aid of a d.c. current pulse through the wire.

In chapter 2.0 some mechanical problems are discussed. The properties of the applied ferrite are given in chapter 3.0. In chapter 4.0 the experimental results are presented. The measurement set-up is given in figure 2, and a description is given in report [2].

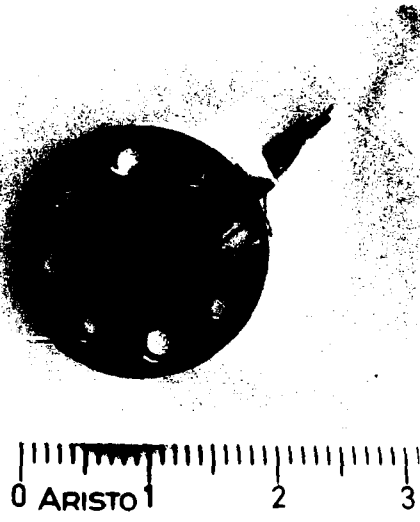

Figure 1 The 92-96 GHz ferrite phase shifter.

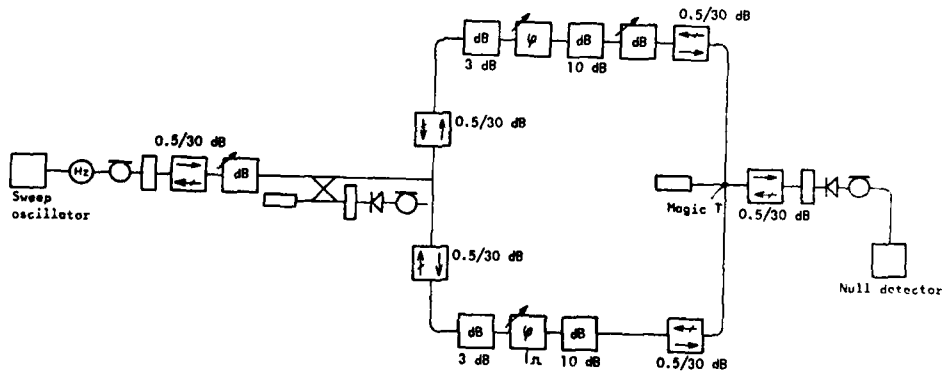

Figure 2 The measurement set-up.

2 PHASE SHIFTER DESIGN

The phase shifter consists of two waveguide flanges which are soldered on a piece of standard (WR-10) waveguide (fig.3).

The ferrite rod is placed in the middle of the waveguide between two $\lambda/4$ wavelength matching transformers.

The hole in the the ferrite rod has a diameter of 0.25 mm. The position of this hole is unfortunately eccentric. The minimum thickness of the ferrite wall is 0.37 mm. This reduces the effective area with 45% (fig.4).

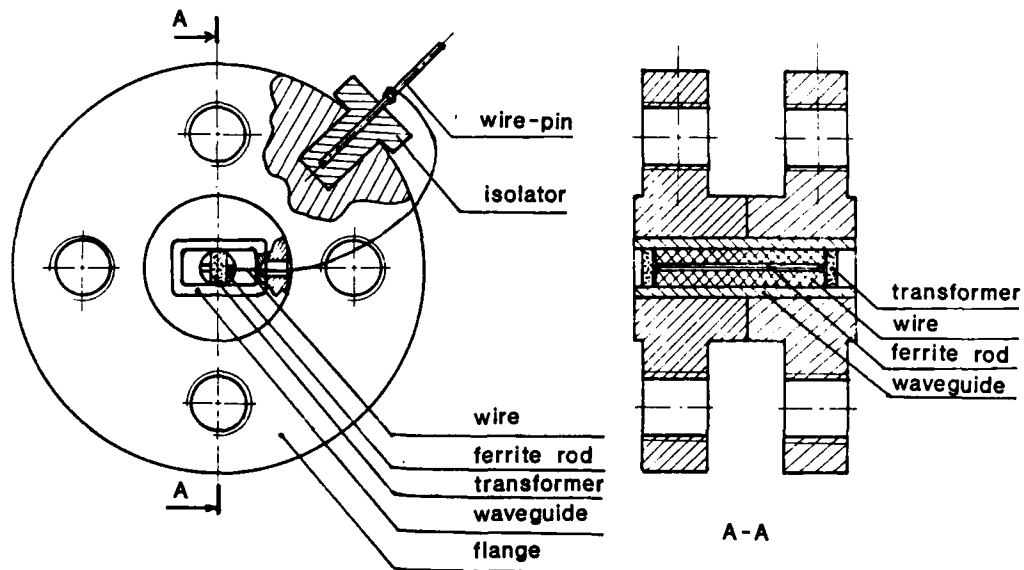

Figure 3: Phase shifter configuration.

The manufacturing of the forsterite matching transformers ($\epsilon_r = 6$) was very difficult. The sizes are given in table 1.

Transformer sizes (mm)		
Calculated		
height	width	length
1.27	0.38	0.46
Manufactured		
height	width	length
1.276	0.368	0.491
1.28	0.398	0.48

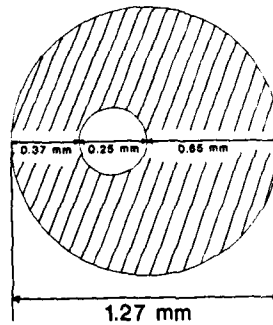

Table 1 Transformer sizes calculated and manufactured

Figure 4 Ferrite rod with eccentric axial hole.

It was not only impossible to make these transformers accurately, but when these transformers were placed into the waveguide some forsterite crumbled off.

The switching wire has a diameter of 0.1 mm and is led through the hole of the ferrite rod. To avoid an air gap between the ferrite and the transformer a groove of 0.12 mm has been made at the ends of the rod. The wire is led out through these grooves and the broad waveguide wall and then soldered to isolation plugs.

3 GENERAL FERRITE PROPERTIES

The R1MH lithium ferrite has been delivered by MARCONI.
In table 2 the general properties of this ferrite are given.

$4\pi M_s = 4810$ (gauss)	$\gamma 4\pi M_s / \omega_0 = 1.4$
$\tan \delta_e = 3.9 \times 10^{-4}$	$\epsilon_r' = 15.1$
$B_r / B_m \leq 0.85$	$\Delta H_e = 216$ (oersted)

Table 2 Properties of the applied ferrite.

$4\pi M_s$	-	Saturation magnetization
$\tan \delta_e$	-	Dielectric loss constant
B_r / B_m	-	Squareness ratio
γ	-	Gyromagnetic ratio (2.8×10^6)
ω_0	-	Angular frequency (94GHz)
ΔH_e	-	Resonance line width (-3dB)

Where 1 oersted = $10^3/4\pi$ A/m and 1 gauss = 10^{-4} Wb/m².

Generally the $4\pi M_s$ value is chosen such, that $\gamma 4\pi M_s / \omega_0 = 0.6$. [3] In this case however $\gamma 4\pi M_s / \omega_0 = 0.14$. This result in a smaller differential phase shift and a larger ferrite length is necessary to achieve more differential phase shift. A longer phase shifter results in an increase of magnetic losses and dielectric losses. However, because of a low $\gamma 4\pi M_s / \omega_0$ value magnetic losses become less dominant.

4 EXPERIMENTAL RESULTS

In figure 5 the saturation differential phase shift is given. We measured an average phase shift of 92.5 degrees. To achieve a differential phase shift of 360 degrees we should use a ferrite length of 38mm, or a larger ferrite diameter. The differential phase shift is almost independent of frequency.

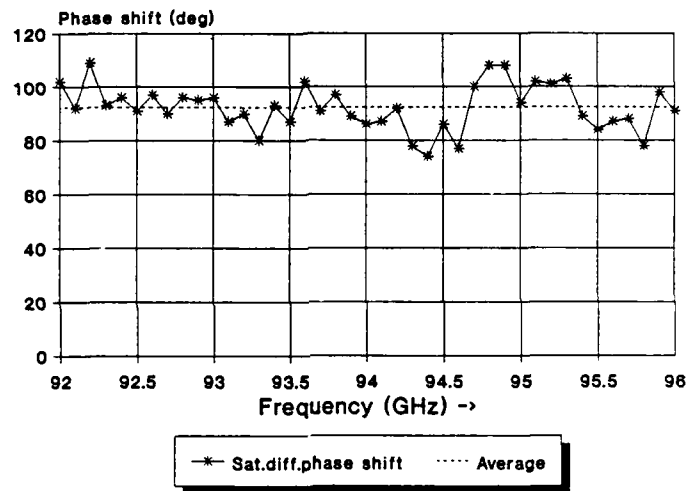

Figure 5 The saturation differential phase shift as a function of frequency.

Figure 6 shows the current pulse as a function of time for 5 different phase settings. To get a 90% saturation phase shift a current pulse of 2 ampere with a pulse length of 650 nsec was used. The voltage pulse for this phase setting was 14 volt with a pulse length of 300 nsec. Unfortunately the current fall-time is 950 nsec. To create a 100% saturation phase shift the current is 13 ampere and the pulse length is 2 μ sec. This is illustrated in figure 7.

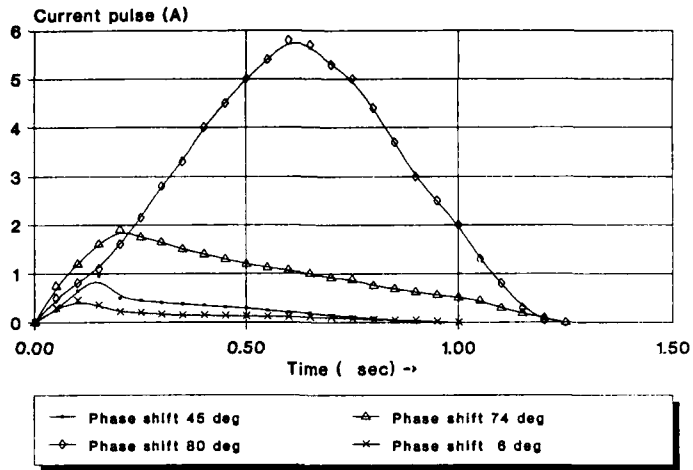

Figure 6 The current pulse as a function of time for 4 different phase settings.

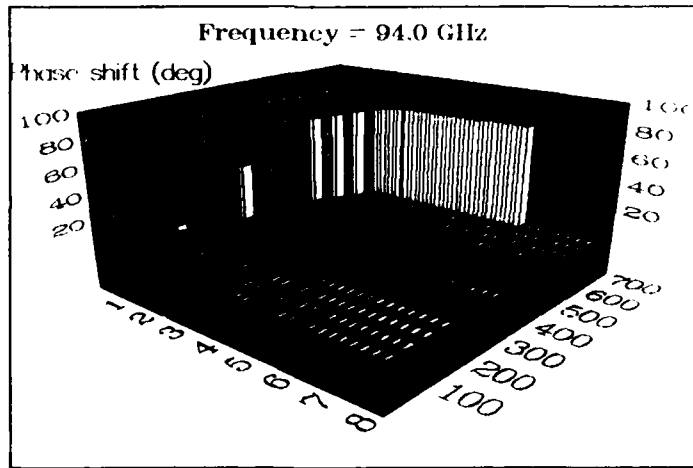

Figure 7 The differential phase shift as a function of current pulse amplitude and width.

Figure 8 shows the insertion loss as a function of frequency measured for different phase settings. A large insertion loss peak is present at 94.4 GHz. This peak is caused by unwanted waveguide modes. Due to the ferrite loading, these modes can propagate. They are generated by any disturbance inside the waveguide such as air gap or void reflections [4].

An increase of the ferrite length will also increase the insertion loss. With a better phase shifter design, where the ferrite makes good contact with the waveguide wall, it is expected to achieve 2 dB loss for a 360 degrees phase shift.

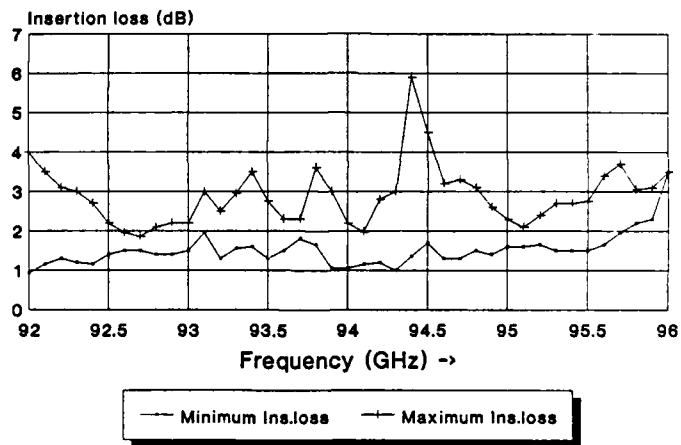

Figure 8 Insertion loss of the phase shifter as a function of frequency for different phase settings.

5 DISCUSSION AND CONCLUSION

Because of mechanical uncertainties we chose for a ferrite length of 10 mm. The ferrite diameter is 1.27 mm.

The manufacture and the installation of the matching transformers was difficult. The accuracy is just 6.7% and the forsterite crumbled off. The average differential phase shift is 92.5 degrees and is almost independent of frequency.

The insertion loss is 1.5-2.5 dB. This can be improved by a better design. Air gaps between ferrite and waveguide wall must be avoided. The pulse length to achieve a 90% saturation phase shift is 650 nsec. The fall-time is then 950nsec.

Based on the experience obtained during the design and construction of this ferrite phase shifter for the 92-96 GHz band, it is concluded that such a phase shifter is feasible.

The experiment will be continued with reproduction measurements.

6 ACKNOWLEDGMENT

The author likes to thank mr.P.W.Kuivenhoven and mr.F.C.Sturm for their skilful manufacturing of the phase shifter.



Ir. G.A. van der Spek
(Group leader)

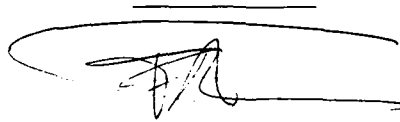

Dhr. F.A. Nennie
(Author)

REFERENCES

- [1] Dr. J. Snieder and F.A. Nennie
Feasibility study of a non-reciprocal latched ferrite phase shifter in the 52-66 GHz frequency band.
PHL 1983-08, march 1983
Physics Laboratory TNO (the Hague)
- [2] Ir. A. v. Ardenne
An experimental study of a latched non-reciprocal ferrite phase shifter at X-band.
PHL 1975-50, December 1975
Physics Laboratory TNO (the Hague)
- [3] J.J. Green and H.J. v. Hook
Microwave properties of lithium ferrites.
IEEE Transactions on micr.theory and techn. February 1977
- [4] R.W. Rabitt, R.A. Stern, L.R. Whicker and C.W. Young
Phase control elements for millimetre wave systems.
AGARD conference preprint No.245

REPORT DOCUMENTATION PAGE

(MOD-NL)

1. DEFENSE REPORT NUMBER (MOD-NL) TD90-1230	2. RECIPIENT'S ACCESSION NUMBER	3. PERFORMING ORGANIZATION REPORT NUMBER FEL-90-B114
4. PROJECT/TASK/WORK UNIT NO. 22052	5. CONTRACT NUMBER	6. REPORT DATE APRIL 1990
7. NUMBER OF PAGES 14	8. NUMBER OF REFERENCES 4	9. TYPE OF REPORT AND DATES COVERED FINAL REPORT
10. TITLE AND SUBTITLE FEASIBILITY STUDY OF A NON-RECIPROCAL LATCHED FERRITE PHASE SHIFTER IN THE 92-96 GHZ FREQUENCY BAND		
11. AUTHOR(S) F.A. NENNIE		
12. PERFORMING ORGANIZATION NAME(S) AND ADDRESS(ES) TNO PHYSICS AND ELECTRONICS LABORATORY POBOX 96468, 2509 JG, THE HAGUE, THE NETHERLANDS		
13. SPONSORING/MONITORING AGENCY NAME(S)		
14. SUPPLEMENTARY NOTES		
15. ABSTRACT (MAXIMUM 200 WORDS, 1044 POSITIONS) A CYLINDRICAL LITHIUM FERRITE ROD WITH A DIAMETER OF 1.27 MM AND AN AXIAL HOLE OF 0.25 MM WAS PLACED IN THE MIDDLE OF A STANDARD WAVEGUIDE. BECAUSE OF MECHANICAL UNCERTAINTIES WE CHOSE FOR A FERRITE LENGTH OF 10 MM. THE AVERAGE DIFFERENTIAL SATURATION PHASE SHIFT AT 92-96 GHZ IS 92.5 DEGREES. OVER A 4 GHZ FREQUENCY BAND THE DIFFERENTIAL SATURATION PHASE SHIFT IS INDEPENDENT OF FREQUENCY. THE INSERTION LOSS OF 1.5-2.5 DB CAN BE IMPROVED THE RISE TIME OF THE 90% SATURATION PULSE IS 100 NSEC, THE PULSE LENGTH IS 650 NSEC AND THE FALL TIME IS 950 NSEC.		
16. DESCRIPTORS FERRITE PHASE SHIFTER FEASIBILITY STUDIES	IDENTIFIERS	LITHIUM FERRITE 94 GHZ W - BAND NON-RECIPROCAL
17a. SECURITY CLASSIFICATION (OF REPORT) UNCLASSIFIED	17b. SECURITY CLASSIFICATION (OF PAGE) UNCLASSIFIED	17c. SECURITY CLASSIFICATION (OF ABSTRACT) UNCLASSIFIED
18. DISTRIBUTION/AVAILABILITY STATEMENT UNLIMITED AVAILABILITY		17d. SECURITY CLASSIFICATION (OF TITLES) UNCLASSIFIED