

FOREIGN TECHNOLOGY DIVISION



INTERLOCK DEVICE

by

Yu. A. Anan'yev, V. F. Borisov, et al.

AD-A225 261

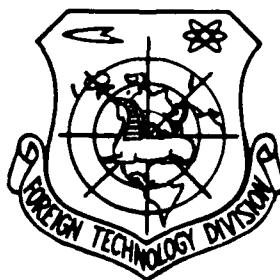

DTIC
ELECTE
AUG 15 1990

cc E D

Approved for public release;
Distribution unlimited.



HUMAN TRANSLATION

FTD-ID(RS)T-04 10-90

12 June 1990

MICROFICHE NR: FTD-90-C-00060-

INTERLOCK DEVICE

By: Yu. A. Anan'yev, V. F. Borisov, et al.

English pages: 4

Source: USSR Patent Nr. 421084, 25 April 1972,
pp. 1-2

Country of origin: USSR

Translated by: Leo Kanner Associates
F33657-88-D-2188

Requester: FTD/TTTD/Jacobsen

Approved for public release; Distribution unlimited.
Other requests for this document shall be referred to
FTD/STINFO.

THIS TRANSLATION IS A RENDITION OF THE ORIGINAL FOREIGN TEXT WITHOUT ANY ANALYTICAL OR EDITORIAL COMMENT STATEMENTS OR THEORIES ADVOCATED OR IMPLIED ARE THOSE OF THE SOURCE AND DO NOT NECESSARILY REFLECT THE POSITION OR OPINION OF THE FOREIGN TECHNOLOGY DIVISION

PREPARED BY.

TRANSLATION DIVISION
FOREIGN TECHNOLOGY DIVISION
WPAFB OHIO

U. S. BOARD ON GEOGRAPHIC NAMES TRANSLITERATION SYSTEM

Block	Italic	Transliteration	Block	Italic	Transliteration
А а	<i>А а</i>	A, a	Р р	<i>Р р</i>	R, r
Б б	<i>Б б</i>	B, b	С с	<i>С с</i>	S, s
В в	<i>В в</i>	V, v	Т т	<i>Т т</i>	T, t
Г г	<i>Г г</i>	G, g	У у	<i>У у</i>	U, u
Д д	<i>Д д</i>	D, d	Ф ф	<i>Ф ф</i>	F, f
Е е	<i>Е е</i>	Ye, ye; E, e*	Х х	<i>Х х</i>	Kh, kh
Ж ж	<i>Ж ж</i>	Zh, zh	Ц ц	<i>Ц ц</i>	Ts, ts
З з	<i>З з</i>	Z, z	Ч ч	<i>Ч ч</i>	Ch, ch
И и	<i>И и</i>	I, i	Ш ш	<i>Ш ш</i>	Sh, sh
Й й	<i>Й й</i>	Y, y	Щ щ	<i>Щ щ</i>	Shch, shch
К к	<i>К к</i>	K, k	Ъ ъ	<i>Ъ ъ</i>	"
Л л	<i>Л л</i>	L, l	Ы ы	<i>Ы ы</i>	Y, y
М м	<i>М м</i>	M, m	Ь ь	<i>Ь ь</i>	'
Н н	<i>Н н</i>	N, n	Э э	<i>Э э</i>	E, e
О о	<i>О о</i>	O, o	Ю ю	<i>Ю ю</i>	Yu, yu
П п	<i>П п</i>	P, p	Я я	<i>Я я</i>	Ya, ya

*ye initially, after vowels, and after ѣ, ь; e elsewhere.
 When written as ѣ in Russian, transliterate as yě or ě.

RUSSIAN AND ENGLISH TRIGONOMETRIC FUNCTIONS

Russian	English	Russian	English	Russian	English
sin	sin	sh	sinh	arc sh	\sinh^{-1}
cos	cos	ch	cosh	arc ch	\cosh^{-1}
tg	tan	th	tanh	arc th	\tanh^{-1}
ctg	cot	cth	coth	arc cth	\coth^{-1}
sec	sec	sch	sech	arc sch	sech^{-1}
cosec	csc	csch	csch	arc csch	csch^{-1}

Russian	English
---------	---------

rot	curl
lg	log

GRAPHICS DISCLAIMER

All figures, graphics, tables, equations, etc.
 merged into this translation were extracted
 from the best quality copy available.

against surges.

This purpose is realized by the fact that the device also includes a time relay, current sensors in each load branch, and current recording cells with a single output and two inputs, one of which are interconnected with each other and are connected to the output of a control pulse generator, and the others are connected to the outputs of the corresponding current sensors. All the outputs of the current recording cells are connected to the firing unit of the interlock discharger, and the output of the time relay is connected to the input of the control pulse generator.

Shown in the drawing is a block diagram of the proposed device.

The interlock device contains (parallel-connected to each other) an inductive storage 1, load 2 in the form of m branches, each consisting of n series-connected gas-filled flash tubes, an interlock discharger 3 with a firing unit 4 and a current supply 5 connected across a current commutator 6 to the inductive storage, time relay 7, control pulse generator 8, current sensors 9 ($9_a, 9_b, \dots, 9_m$), connected in each load branch, current recording cells 10 ($10_a, 10_b, \dots, 10_m$), flash tube firing element 11, and adder 12, which can be added to the device for certain operating conditions.

Some inputs of the current recording cells 10 are interconnected to each other and are connected to the output of the control pulse generator 8, the other inputs are connected to the outputs of the corresponding current sensors 9. The outputs of the current recording cells are connected to the firing unit 4 of the interlock discharger 3, and the output of the time relay 7 is connected to the input of the control pulse generator 8.

Inductive storage 1 is charged from current supply 5 across a closed current commutator 6. On completion of the charging, the current commutator disconnects the inductive storage 1 and triggers time relay 7 and firing element 11 of the load flash tubes 2.

After a certain time period, which depends on the flash tube heating time and its scatter from the instant that commutation begins, with an output pulse time relay 7 starts up control pulse generator 8; a pulse from the latter arrives at the current recording cells 10, made, for example, in the form of switching circuits, and serves for interrogating their state. The current recording cells 10 are controlled by current sensors 9 connected to each load branch 2. The outputs of the current recording cells 10 are connected to the input of the firing unit 4 of the interlock discharger 3 directly, if the interlock device must be triggered when one of the m branches fails. The current recording cell that records the absence of current in the parallel load branch corresponding to it sends an interrogation pulse from the control pulse generator to the firing unit of the interlock discharger.

If a certain number of failures of the total number m of load branches is deliberately allowed, control of interlock discharger firing is exercised by means of adder 12, which connects the interlock discharger if the number of failures exceeds a given number. The outputs of the current recording cells 10 are connected to adder 12, which stores data on the number of load tube failures and generates the control pulse to start the interlock discharger.

Claim of Invention

Interlock device containing (parallel-interconnected) an inductive storage, loads in the form of n series-connected gas-

filled flash tubes, an interlock discharger with a firing unit, a current supply connected across a current commutator to the inductive storage, a control pulse generator, and a flash tube firing unit, is distinguished by the fact that, to protect flash tubes from surges, to the unit there are added a time relay, current sensors connected in each load branch, current recording cells with one output and two inputs, some of which are interconnected to each other and are connected to the output of the control pulse generator, and the others are connected to the outputs of the corresponding current sensors. All outputs of the current recording cells are connected to the interlock discharger firing unit, and the time relay output is connected to the control pulse generator input.

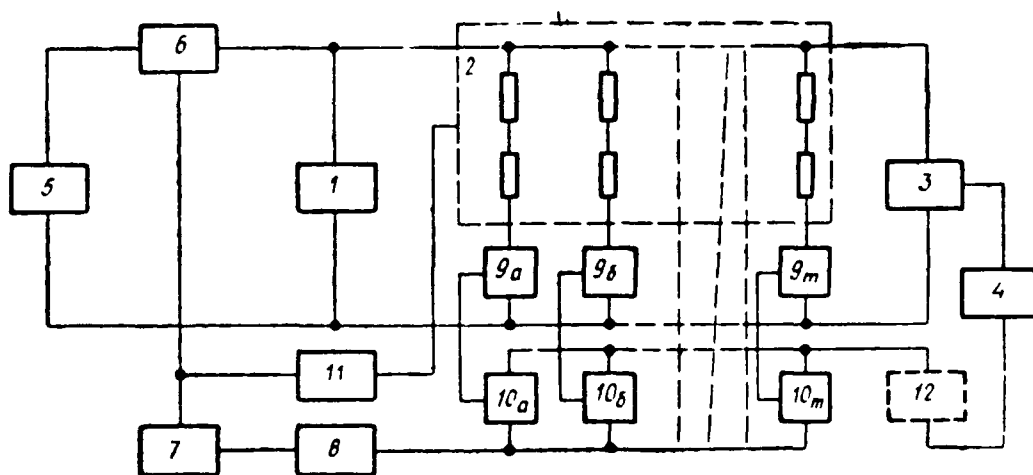

DISTRIBUTION LIST

DISTRIBUTION DIRECT TO RECIPIENT

<u>ORGANIZATION</u>	<u>MICROFICHE</u>
C509 BALLISTIC RES LAB	1
C510 R&T LABS/AVEADCOM	1
C513 ARRADCOM	1
C535 AVRADCOM/TSARCOM	1
C539 TRASANA	1
Q591 FSTC	4
Q619 MSIC REDSTONE	1
Q008 NTIC	1
E053 HQ USAF/INET	1
E404 AEDC/DOF	1
E408 AFWL	1
E410 AD/IND	1
F429 SD/IND	1
P005 DOE/ISA/DDI	1
P050 CIA/OCR/ADD/SD	2
AFIT/LDE	1
NOIC/OIC-9	1
CCV	1
MIA/PHS	1
LLYL/CODE L-309	1
NASA/NST-44	1
NSA/T513/TDL	2
ASD/FTD/TTIA	1
FSL	1