

DTIC

COPY

2

NAVAL POSTGRADUATE SCHOOL Monterey, California

AD-A225 330



DTIC
ELECTE
AUG 17 1990
S B D
Co

THESIS

A COMBINED OPTICAL AND COLLECTION
PROBE FOR SOLID PROPELLANT
EXHAUST PARTICLE ANALYSIS

by

Timothy J. Eno

December, 1989

Thesis Advisor:

D. W. Netzer

Approved for public release; distribution is
unlimited.

REPORT DOCUMENTATION PAGE

1a. REPORT SECURITY CLASSIFICATION UNCLASSIFIED		1b. RESTRICTIVE MARKINGS	
2a. SECURITY CLASSIFICATION AUTHORITY		3. DISTRIBUTION/AVAILABILITY OF REPORT approved for Public Release; distribution is unlimited.	
2b. DECLASSIFICATION/DOWNGRADING SCHEDULE			
4. PERFORMING ORGANIZATION REPORT NUMBER(S)		5. MONITORING ORGANIZATION REPORT NUMBER(S)	
6a. NAME OF PERFORMING ORGANIZATION Naval Postgraduate School	6b. OFFICE SYMBOL (If applicable) Code 67	7a. NAME OF MONITORING ORGANIZATION Naval Postgraduate School	
6c. ADDRESS (City, State, and ZIP Code) Monterey, California 93943-5000		7b. ADDRESS (City, State, and ZIP Code) Monterey, California 93943-5000	
8a. NAME OF FUNDING / SPONSORING ORGANIZATION Air Force Astronautics Laboratory	8b. OFFICE SYMBOL (If applicable)	9. PROCUREMENT INSTRUMENT IDENTIFICATION NUMBER	
8c. ADDRESS (City, State, and ZIP Code) Edwards Air Force Base California		10. SOURCE OF FUNDING NUMBERS	
		PROGRAM ELEMENT NO. E04611	PROJECT NO. 89-X006
		TASK NO.	WORK UNIT ACCESSION NO.
11. TITLE (Include Security Classification) A Combined Optical and Collection Probe for Solid Propellant Exhaust Particle Analysis			
12. PERSONAL AUTHOR(S) Eno, Timothy J.			
13a. TYPE OF REPORT Master's Thesis	13b. TIME COVERED FROM _____ TO _____	14. DATE OF REPORT (Year, Month, Day) December 1989	15. PAGE COUNT 70
16. SUPPLEMENTARY NOTATION The views expressed in this thesis are those of the author and do not reflect the official policy or position of the Department of Defense or the U.S. Government.			
17. COSATI CODES		18. SUBJECT TERMS (Continue on reverse if necessary and identify by block number)	
FIELD	GROUP	SUB-GROUP	
		Solid Propellant Collection Probe Particle Size Distribution	
19. ABSTRACT (Continue on reverse if necessary and identify by block number) A combined optical and collection probe for solid propellant rocket motor exhaust particle analysis was designed and utilized in initial experiments with a sub-scale rocket motor. Shock swallowing capabilities of the probe were verified under restricted motor operations using a schlieren system. Window purge and ejector design were shown to be capable of keeping the probe windows clean when the probe was placed approximately 14 nozzle diameters downstream of the exhaust nozzle. The exhaust deflection device allowed sampling to occur during the minimum time required to reach steady flow within the probe. A MALVERN Mastersizer was used for in situ measurements of the particles, and a collection filter at the aft end of the probe was partially successful in capturing the probe flow. Suggestions are made for probe improvements and future investigations.			
20. DISTRIBUTION/AVAILABILITY OF ABSTRACT <input checked="" type="checkbox"/> UNCLASSIFIED UNLIMITED <input type="checkbox"/> SAME AS RPT <input type="checkbox"/> DTIC USERS		21. ABSTRACT SECURITY CLASSIFICATION Unclassified	
22a. NAME OF RESPONSIBLE INDIVIDUAL Prof. D. W. Netzer		22b. TELEPHONE (Include Area Code) (408) 646-2980	22c. OFFICE SYMBOL Code 67NT

Approved for public release; distribution is unlimited.

A Combined Optical and Collection
Probe for Solid Propellant
Exhaust Particle Analysis

by

Timothy J. Eno
Captain, United States Army
B.S., United States Military Academy

Submitted in partial fulfillment
of the requirements for the degree of

MASTER OF SCIENCE IN ENGINEERING SCIENCE

from the

NAVAL POSTGRADUATE SCHOOL

December 1989

Author:

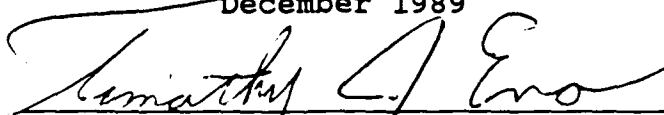

Timothy J. Eno

Approved by:

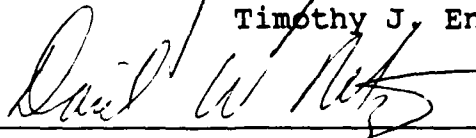

D. W. Netzer

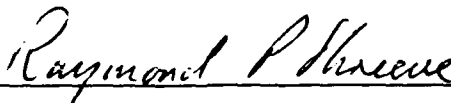

R. P. Shreeve



E. R. Wood, Chairman

Department of Aeronautics and Astronautics

ABSTRACT

A combined optical and collection probe for solid propellant rocket motor exhaust particle analysis was designed and utilized in initial experiments with a sub-scale rocket motor. Shock swallowing capabilities of the probe were verified under restricted motor operations using a schlieren system. Window purge and ejector design were shown to be capable of keeping the probe windows clean when the probe was placed approximately 14 nozzle diameters downstream of the exhaust nozzle. The exhaust plume deflection device allowed sampling to occur during the minimum time required to reach steady flow within the probe. A MALVERN Mastersizer was used for in situ measurements of the particles, and a collection filter at the aft end of the probe was partially successful in capturing the probe flow. Suggestions are made for probe improvements and future investigations.



Accession For	
NTIS GRA&I	<input checked="" type="checkbox"/>
DTIC TAB	<input type="checkbox"/>
Unannounced	<input type="checkbox"/>
Justification	
By _____	
Distribution/	
Availability Codes	
Dist	Avail and/or Special
A-1	

TABLE OF CONTENTS

I. INTRODUCTION	1
II. EXPERIMENTAL APPARATUS	5
A. BACKGROUND	5
B. EQUIPMENT	5
1. Three Dimensional Subscale Motor	5
2. Flow Deflection Device	6
3. MALVERN Mastersizer	7
4. Particle Collection Probe	9
III. EXPERIMENTAL PROCEDURE	12
A. MALVERN VALIDATION	12
B. PROBE DESIGN VALIDATION	12
1. Schlieren Examination	13
2. Window Purge	14
3. Transmissivity Measurements	14
C. PRE-FIRING PREPARATION	15
D. FIRING SEQUENCE	17
E. COLLECTION MEASUREMENTS	18
IV. RESULTS AND DISCUSSION	20

A. SCHLIEREN EXAMINATION	20
B. WINDOW PURGE	21
C. TRANSMISSIVITY MEASUREMENTS	23
D. TEST FIRING	25
V. CONCLUSIONS AND RECOMMENDATIONS	30
APPENDIX A - MALVERN VALIDATION	33
A. SIZING OF KNOWN DISTRIBUTIONS	35
B. SUB-RESOLUTION LIMIT PARTICLES	35
C. SENSITIVITY TO REFRACTIVE AND ABSORPTIVE INDICES	37
APPENDIX B - TABLES	39
APPENDIX C - FIGURES	42
LIST OF REFERENCES	57
INITIAL DISTRIBUTION LIST	59

LIST OF TABLES

I PROPELLANT COMPOSITION BY WEIGHT PERCENTAGE 39

II SAMPLE VERSUS MEASURED MEAN DIAMETERS
FOR POLYSTYRENE SPHERES 40

III EFFECT OF SUB-RESOLUTION LIMIT PARTICLES
ON BI-MODAL DISTRIBUTIONS 41

LIST OF FIGURES

2.1	Three-Dimensional Subscale Motor	42
2.2	Flow Deflection Device	43
2.3	Particle Collection Probe	43
2.4	Cutaway View of Tip Interior	44
2.5	Cutaway View of Probe Head	44
4.1	Schlieren Experiment	45
4.2	Cutaway View of Tip Modification	45
4.3	Cutaway View of Probe Head Modification	46
4.4	Transmittance Experiment	47
4.5	New Particle Collection Method	47
4.6	Test Firing Arrangement	48
4.7	Effects of Beam Steering	48
4.8	Test Firing Pressure-Time Trace	49
4.9	Test Firing - Before Deflector Activation	49
4.10	Test Firing - After Deflector Activation	50
4.11	Mastersizer Results - Test Firing	50
4.12	Window Obscuration	51
A.1	Output for a Known Particle Diameter (9.6 Microns)	51
A.2	Output for a Known Particle Diameter (2.062 Microns)	52
A.3	Output for a Known Particle Diameter (0.511 Microns)	52

A.4	Bi-Modal Sample (2.062 + 0.364 Microns)	53
A.5	Bi-Modal Sample (2.062 + 0.261 Microns)	53
A.6	Bi-Modal Sample (2.062 + 0.109 Microns)	54
A.7	Results for DRI of 1.70 and Ua of 0.00	54
A.8	Results for DRI of 1.70 and Ua of 0.001	55
A.9	Results for DRI of 1.70 and Ua of 0.01	55
A.10	Results for DRI of 1.55 and Ua of 0.00	56
A.11	Results for DRI of 2.06 and Ua of 0.00	56

LIST OF SYMBOLS

DRI	Differential Refractive Index
PSIA	Pounds Per Square Inch Absolute
Ua	Sample Absorptive Index

ACKNOWLEDGEMENTS

Completion of this investigation would not have been possible without the help and guidance of Professor Dave Netzer, who made this process as educational, painless, and fun as possible. The technical expertise and sense of humor of Harry Conner were each invaluable, although normally at different times. I would also like to acknowledge the help of Pat Hickey, John Moulton, and Don Harvey. Their abilities made my very rough plans reality.

I. INTRODUCTION

Characterization of exhaust products continues to be of importance in the design of solid propellant rocket motors. Spectral signature predictions made by computer codes such as SPF/SIRRM are extremely sensitive to input particle sizes, especially in plumes with large mass fractions of aluminum or zirconium, which are typically found in high temperature, high performance SRM propellants [Ref. 1]. A knowledge of the particle size and distribution in the exhaust plume is vital to allow for accurate prediction of the radiation signatures generated by the motor during its burn.

A number of different methods have been proposed to attempt to study these particle distributions. These include:

1. scattered light measurements,
2. transmitted light measurements, and
3. particulate collection.

The problems inherent in the use of these methods are numerous. Attempts to make light transmission or scattering measurements through plumes of even moderately aluminized propellants are defeated by the problems of both multiple scattering of light and beam extinction [Ref. 2]. At least four basic problems must be overcome to allow for the unbiased

collection of an exhaust products sample from an exhaust plume, namely;

1. the possibility of bias of the sample by disturbing the flow in the stream tube to be captured;
2. the possibility of particle entrainment effects from the atmosphere which can introduce foreign particles into the sample;
3. agglomerates of smaller particles may be broken up during collection and subsequent handling; and
4. particles may continue to react after they have been captured, thus obscuring the true size and nature of the particles in the plume. [Ref.1]

Previous attempts have been made to determine particle distributions in the exhaust plume using all of the above methods. Various light scattering techniques have been used at NPS in conjunction with both two- and three-dimensional subscale motors to examine particle sizes in the motor, nozzle, and exhaust plume [Ref. 3]. The use of a two-dimensional motor setup allowed the use of these methods by keeping the flow thin enough to allow obscuration and multiple scattering problems to be minimized. A subsequent result of the use of two-dimensional rocket motors, however, is the inability to examine the distribution of particles which would be expected from a nozzle of circular cross-section. The use of a single wavelength transmissometer to determine a Sauter mean diameter in the exhaust of reduced smoke propellants has been reported by Misener [Ref. 1], among others. The requirements for use of a reduced smoke propellant to allow

for minimum multiple scattering and particle coincidence effects limit the usefulness of this method. In addition, assumptions must be made concerning the particle index of refraction and the shape of the particle size distribution. Collection of exhaust products has been achieved by a number of different means. The supersonic shock swallowing probe designed by the Air Force Rocket Propulsion Laboratory (AFRPL) is one method which has also been applied at NPS [Ref. 4]. The shortcoming of this method is that the shock interactions within the probe have not been quantified, and thus their effect on the resultant collected particle sample is unknown.

This investigation was an attempt to overcome the shortcomings of the above methods by using two different methods simultaneously to gather data on a captured sample of an exhaust plume. The purpose of the probe designed for this experiment was to

1. capture a supersonic stream tube of the exhaust plume through the use of a shock swallowing tip modeled on that of the AFRPL probe,
2. measure the size distribution of the captured plume particles in situ through the use of a MALVERN Mastersizer particle sizing apparatus, and
3. collect the captured particles to examine their size distribution and compare it to the observations made in the stream tube by the Mastersizer.

The probe design was based on both the original shock swallowing probe designed by AFRPL and on the constraints

imposed on the probe by the use of the MALVERN Mastersizer particle sizing apparatus.

II. EXPERIMENTAL APPARATUS

A. BACKGROUND

A three dimensional subscale rocket motor, a flow deflection device, a particle collection probe, and a Mastersizer particle sizing apparatus were used in the course of this experiment. Initial verification of the Mastersizer's particle sizing ability was accomplished to increase confidence in the results achieved with the equipment.

B. EQUIPMENT

1. Three Dimensional Subscale Motor

The solid propellant rocket motor used in this experiment was the same as that use by Pruitt [Ref. 3] and Youngborg [Ref. 5]. The chamber diameter was 2.00 inches and the propellant was cut into cylindrical slabs approximately 1.98 inches in diameter and 1.00-1.25 inches thick. All experimental runs were conducted with end burning grains. For additional motor specifications see Walker [Ref. 6].

Figure 2.1 shows the motor used in this investigation. The windows in the motor, used previously for holographic imaging of burning particles, were simply replaced with stainless steel blanks and the nitrogen purge lines were capped. The nozzles used in this experiment were fabricated

either from copper or graphite and were sized in order to obtain desired combustion chamber pressures and expansion ratios for the exhaust plume.

Ignition of the propellant was accomplished using a BKNO_3 ignitor, which was fired by means of a nichrome filament energized by a 12 volt DC power source from within the control room.

The propellant was bonded to the motor casing using a self-vulcanizing silicone rubber compound (RTV). Various propellants were used during the initial testing of the probe design.

2. Flow Deflection Device

The flow deflection device depicted in Figure 2.2 consisted of a steel plate mounted on a frame and spring loaded in the up position. It was activated by a National Acme Co. 110 volt AC, 3 ampere solenoid.

The purpose of the deflection plate was two-fold. First, it was designed to help assure the survival of the tip of the collection probe in the aggressive environment of the exhaust plume by limiting the amount of time that the tip was exposed to the flow. Secondly, through control of the plate activation by the Hewlett Packard acquisition system, the collected sample could be kept free of the byproducts of the motor ignition and burn tail-off by allowing collection only during the steady state portion of the motor burn.

3. MALVERN Mastersizer

The MALVERN Mastersizer (Mastersizer) is a commercially produced system designed to use forward scattering of an incident collimated laser beam to determine particle sizes and distributions. The software used to determine particle distributions is considered proprietary in nature, and thus the details of the algorithm used were unavailable.

The Mastersizer uses a 2mW helium-neon (He-Ne) laser (633 nanometer wavelength), with beam expansion to 18 millimeters (mm). The beam is collimated and spatially filtered for the TEM 00 mode. The laser and receiver units are both mounted on a rigid optical bench, which also allows for the mounting of various sample presentation cells and accessories.

The receiver unit can be used with three interchangeable lenses of focal lengths 45, 100, and 300 mm. The 45 mm lens is used as a reverse Fourier transform lens and requires the use of a special presentation cell. The 100 and 300 mm lenses are used as Fourier transform lenses. The particle sizing ranges for the lenses are 0.1-80, 0.5-170, and 1.20-600 microns respectively. The dynamic range of each lens is 800:1 and the accuracy claimed for the system is +/- 4% for a volume median diameter [Ref. 7]. The 100 mm lens was used

for the in situ measurements , and the 45 mm lens was used for the examination of the collected particulate exhaust products.

The Mastersizer detector uses a 31 element solid state detector array consisting of 31 individual chips mounted in a single pie shaped array. The chips are sampled in parallel through individual amplifiers. Use of on-board digital storage allows for the sampling of all 31 detectors in approximately 10 microseconds, although the proprietary software used by the system causes the read-in time to the controlling AT&T 6286 computer to be approximately 7.5 milliseconds. Thus, the detector chips can only be swept and read every 7.5 milliseconds. The average of the detector values over the number of diode sweeps input by the user determines the values used by the computer to calculate the size distribution of the particles present in the beam.

The MALVERN 2600 system used in previous experiments at NPS [Ref. 8] based its data reduction strictly on Fraunhofer diffraction theory, with the subsequent result that no accurate measurements for particles smaller than approximately 2 microns could be achieved. The field of view of the MALVERN 2600 was limited to 14 degrees in the forward direction. The Mastersizer, on the other hand, allows the user to input a differential refractive index and absorption index value, if the required values are within those tabulated in the Malvern instruction manual and supplied with the system.

In addition, the forward scattering is measured to a maximum angle of approximately 50.4 degrees. These improvements permit Mie corrections to the Fraunhofer diffraction theory to be made, allowing smaller particle sizes to be measured. The Mastersizer also provides for the measurement of multimodal size distributions.

4. Particle Collection Probe

The particle collection probe shown in Figure 2.3 was designed to use some of the features of the AFRPL probe previously mentioned [Ref. 1], and to allow the use of the Mastersizer to obtain in situ measurements of the particle size distribution in the captured exhaust stream tube.

The probe tip was designed so that its external cone angle allowed no bow shock (normal detached shock) formation for any Mach number flow greater than approximately 1.4. All other calculations for the tip were done considering that the flow encountered by the tip was expected to be moving at Mach 2.0 or higher.

The interior of the tip itself (Figure 2.4) was gradually diverging to insure that the shock would be swallowed by the tip. Calculations made along the length of the internal flow of the tip using influence coefficients for the change in area and the expected friction of the walls [Ref. 9] showed that the inlet Mach number at the tip should be only slightly lowered at the tip exit.

The head end of the collection probe (Figure 2.5) served to contain the inlets and exhausts for an ejector flow and the window purge gas. The ejector flow served a number of very important functions in the probe. The first was to lower the back pressure of the capture tube to increase the likelihood of the shock being swallowed. This flow was also needed to provide an annular flow surrounding the captured stream tube to insure that the exhaust products in the plume were not allowed to contact and foul the windows through which the Mastersizer took its measurements. The third purpose of the ejector flow was to quench the incoming flow to increase the chances of filter paper survival at the aft end of the probe, thus allowing the collection of the plume constituents for further examination.

Window purge in the probe head allowed nitrogen to be trailed over the upper surface of the rectangular window to prevent recirculation of the exhaust particles and their deposition on the window surface. This possibility is highly dependent on the location of shocks and expansion waves in the interior of the probe.

The width of the probe body was determined by the constraints placed on sample volume by the use of the Mastersizer for particle sizing. The Mastersizer manual states that the particles to be examined must be within 28.8 mm of the 100 mm lens to avoid the problem of vignetting (loss of

data by scattering past the lens) [Ref.7; p.4.24]. The maximum scattering angle used by the Mastersizer also determined the size of the rectangular window mounted on the detector side of the probe.

The collection end of the probe was initially designed to consist simply of a plate fitted to the aft of the probe, with a support inserted to allow for the use of a standard Millipore 0.25 micron filter. The size of the filter paper area was again dictated by the constraints of the Mastersizer system. Initial experiments resulted in some modifications to this design. These are discussed below.

III. EXPERIMENTAL PROCEDURE

A. MALVERN VALIDATION

Initial measurements were taken with the Mastersizer using polystyrene particles of known mean diameters and standard deviations. These measurements were taken to determine the effect on the calculated distributions of the absorptive index input for the particles and to investigate the effect of particles below the resolution limit of the lens on the distributions.

Appendix A contains the Mastersizer output and discussion of the results obtained in this investigation. To summarize:

1. Particles below the resolution limit of the 100 mm lens (0.5 microns), but above approximately 0.25 microns affected both the distributions and the calculated mean diameters in a significant manner. Particles below this size had only a small effect on the Mastersizer in the calculation of the distributions.
2. Large changes in the absorptive index had a significant effect on the calculated particle distributions. For the range of values of differential refractive index (DRI) and sample absorptive index (U_a) expected to be encountered in the exhaust plumes of aluminized propellants, however, negligible effect on the derived distributions can be expected from small variations in the absorptive index.

B. PROBE DESIGN VALIDATION

Before actual data collection runs were undertaken using the probe, a number of different experiments were made to

determine some of the probe operating characteristics. The questions about the probe characteristics included:

1. Under what conditions (motor chamber pressure and exhaust nozzle Mach number) does the probe tip actually swallow the shock initially formed at the tip?
2. Do the ejector flow and the window purge gas keep the probe windows clear of exhaust products at the expected operating pressures?
3. How much time elapses between the activation of the flow deflection device and the onset of a steady state flow through the probe?
4. Does the ejector flow sufficiently quench the flow so that the filter paper can survive a data run?
5. Will the probe tip survive exposure to the exhaust flow for the period of time required for onset of steady state flow and the in situ data measurements?

The following discussions outline the approach used in each case to answer these questions.

1. Schlieren Examination

A schlieren system was employed to examine the shock swallowing properties of the probe. The probe was mounted aft of a small three dimensional motor and a schlieren system erected around the probe tip. The probe was mounted at a distance of approximately 6.0 inches from the motor nozzle, where the actual data runs were expected to be taken. The probe ejector flow and the window purge were connected to a supply of compressed air through a dome loader, and the motor supplied with compressed air from a separate source through the burst disk outlet. While varying the chamber pressure of

the motor, an examination of the shock pattern around the probe tip was made. A pressure transducer connected to the probe interior allowed examination of the effect of supplied air pressure on the cavity pressure inside the probe. This experiment served to determine the shock swallowing capacity of the probe and if the standard Millipore filters to be used in the investigation would hold up to the expected probe cavity pressures and velocities.

2. Window Purge

The second experiment undertaken with the probe involved the actual firing of the subscale motor. The windows in the probe were shielded from the internal flow of the probe with fitted stainless steel shim stock. The motor was then fired utilizing the data acquisition program designed for the actual investigation. This experiment was designed to check that the data acquisition programs operated as expected, that the probe tip would survive a normal test run, and that the ejector flow and the window purge would indeed keep the exhaust products from being deposited on the windows.

3. Transmissivity Measurements

This test involved another firing of the subscale motor to be used in subsequent data collection. For this firing, a small opening was made in the window covers, and a small He-Ne laser and a photodiode were installed on either side of the probe. The laser, diode, and windows were

protected from the exhaust flow external to the probe by steel tubes which were installed on either side of the probe itself. The photodiode output was connected to a chart recorder to allow for the determination of how long it took for the flow in the probe to effect the transmittance and to also investigate the amount of window fouling still present.

C. PRE-FIRING PREPARATION

Initial preparation of the system for data collection included enclosure of the Mastersizer, mounting of the collection probe to the Mastersizer enclosure, and motor assembly and mounting.

The Mastersizer unit was enclosed in an aluminum box. The purpose of this enclosure was simply to protect the Mastersizer from the aggressive environment of the exhaust plume. The wall of the enclosure to which the probe was to be affixed extended horizontally toward the motor. This was done to allow the exhaust flow from the motor to be directed to the probe without the formation of a bow shock from the flow encountering a flat surface normal to the flow direction. Video records of test firings made prior to the enclosure construction showed that the extended wall did not affect the flow within the center of the plume for a significant distance downstream of the exhaust plane of the nozzle. Therefore, the effects of this extension on the flow being examined were

determined to be negligible.

The collection probe was mounted flush to the detector side of the Mastersizer enclosure for two reasons. The first was that due to the vignetting constraints imposed by the Mastersizer and discussed previously, it was necessary that the volume to be measured by the Mastersizer be within 28.8 mm of the 100 mm lens. The only way to accomplish this without forcing the measured volume to be extremely small was to make the probe an integral part of the enclosure box. The second reason was that it was extremely important to protect the sensitive optics of the Mastersizer system from the aggressive environment of the exhaust plume. This was most easily accomplished by using the probe body as a shield for the lens, effectively sealing the lens environment.

A masking tube was extended from the laser side of the enclosure box to the circular probe window for similar reasons. Both the laser of the Mastersizer and the entrance window of the probe required protection from the exhaust products. In addition, the exhaust flow had to be kept out of the laser sight line outside the probe to allow for an accurate determination of the particle distribution within the probe volume.

After construction of the enclosure and mounting of the probe, a measurement of the background radiation incident on the detectors was taken to insure that the masking tube and

the probe mounting were having no effect on the light passing through the probe.

Propellant for the subscale motor was cut and bonded to the motor casing using a self-vulcanizing silicone rubber compound (RTV). After at least a 24 hour curing period, the motor was assembled and mounted on the test stand for firing. The test stand was then used to align the motor, the flow deflection device, and the probe.

The computer program used to control the firing sequence was then loaded into the Hewlett Packard data acquisition system. This program was an adaptation of the program used by Hovland [Ref.4].

Purge and ejector gas flows to the collection probe were then begun and a sample background taken by the Mastersizer. The pre-assembled BKNO_3 ignitor was then connected to the motor and the system was ready for the motor firing and data collection sequence.

D. FIRING SEQUENCE

The data collection by the Mastersizer was carried out automatically by the computer after a specified threshold pressure was reached and a time delay met. The threshold pressure and time delay were varied to allow the triggering of the flow deflection device and steady state flow to be reached within the probe. The motor combustion pressure trace

reached within the probe. The motor combustion pressure trace and the timing of the trigger pulse to the Mastersizer were acquired and graphed utilizing the Labtech Notebook data acquisition program in conjunction with an IBM PC/AT computer. This program was also triggered by the Hewlett Packard system.

The firing sequence was started manually by applying a voltage to the ignitor. This heated a nichrome wire imbedded in the ignitor, causing combustion to begin in the BKNO_3 , which in turn ignited the propellant in the motor. When the threshold pressure and time delay were met, a trigger activated the flow deflection device. After a set time delay, the Mastersizer was triggered to take its readings, and the deflection device triggered to close again. The Mastersizer automatically transforms the sweeps taken to an average light incidence on each of the 31 detector chips.

E. COLLECTION MEASUREMENTS

At completion of a data run, the probe was removed from the Mastersizer and disassembled. The 0.25 micron filter removed from the probe was then dissolved in an acetone bath in an ultrasonic cleaner. The particles were allowed to settle and the excess solution was then removed. This procedure was continued until the solution remained clear, which signified that the majority of the exhaust products other than the Al_2O_3 had been removed from the solution. The remaining solute was

placed in a sample holder for analysis using the Mastersizer
with the 45 mm lens.

IV. RESULTS AND DISCUSSION

A. SCHLIEREN EXAMINATION

The setup used in the schlieren examination is shown in Figure 4.1. During this part of the investigation, the pressure of the compressed air supplied to the subscale motor was varied to allow examination of the probe characteristics for exhaust flows that were underexpanded, overexpanded, and expanded to atmospheric pressure. The area ratio of the converging/diverging nozzle used for this examination was 3.11, which yields a Mach number of 2.68 at the exhaust plane, and a pressure ratio of 0.0443 [Ref. 10].

Before any examination of the schlieren results were undertaken, a pressure transducer was connected to the pressure tap in the probe to determine the effect of varied purge and ejector pressures on the pressure in the probe cavity. It was quickly determined that the 0.25 micron filter paper being used in the investigation severely restricted the flow leaving the probe, thus causing an extremely large back pressure in the probe. At this point the filter holder and filter paper were removed from the probe.

All examinations of the schlieren were made using a video camera and recorder. Initially it was found that the probe had a very weak normal shock regardless of the variations of

the ejector or motor flows. The interior of the tip was then modified to the configuration shown in Figure 4.2. Further investigation of the modified tip showed that a weak shock remained under all circumstances other than that of a perfectly expanded flow. For this single case, the shock was observed to disappear, only to reappear as the flow was moved from the perfectly expanded state.

The presence of a weak normal shock for those flows not perfectly expanded can be understood in the context of what these flows undergo as they leave the plane of the exhaust nozzle. For both the overexpanded and underexpanded flows, a series of expansions and compressions (shocks) will be formed to allow the flow to attain atmospheric pressure. These resulted in the "shock diamonds" which were clearly visible in the flow forward of the probe tip. They affected the flow Mach number as well as its actual direction [Ref. 9; pp.139-143]. The effect of these shocks on the flow could easily lower the flow Mach number below that required for the shock to be attached to the cone.

B. WINDOW PURGE

The window purge investigation was carried out with a 16% aluminized propellant. The nozzle used in this investigation had an area ratio of 4.94, which yielded an exit plane Mach number of approximately 2.8 and a pressure ratio of 0.031

[Ref.10; p.717]. The combustion chamber pressure reached approximately 550 PSIA, which yielded a slightly underexpanded flow.

The data acquisition program was set to trigger the flow deflection device at a chamber pressure of 400 PSIA with a delay time of 0.2 seconds. The flow deflection device was repositioned 0.5 seconds later.

Upon completion of the run, the probe was removed from the stand and the window covers examined. Both the window covers exhibited a significant amount of deposited material. Upon examination of the probe body itself, it was discovered that flow separation had occurred approximately 1/2 of the way into the ejector nozzle and 180 degrees away from the ejector gas inlet. This was determined to have happened for two reasons:

1. The area ratio of the ejector nozzle (initially designed for sub-atmospheric back pressures) was much larger than required. This yielded flow that was too severely overexpanded to remain attached to the wall of the ejector nozzle.

2. There was no annular manifold in the original probe plans to allow the incoming ejector flow to move around the tip before reaching the area which was expected to act as the throat. This caused the flow to remain preferentially on the side of the tip toward the purge.

These two problems were addressed as shown in Figure 4.3. An insert was designed to be pressed in place to make the ejector outer flow wall straight. Therefore the area ratio of the ejector nozzle was now determined by the angle of the aft end of the tip. This new area ratio was 1.95, which yielded a Mach

number of 2.16 at the ejector exhaust plane and a pressure ratio of 0.0996 [Ref.10; p.712]. Also an annular manifold was added to the ejector design to help equalize the flow around the tip.

The window purge gas was supplied in this examination at a pressure that caused choked flow at the purge gas outlets. Subsequent examinations were carried out with a sonic choke in the window purge line to keep the purge flow from choking at its outlets. This arrangement allowed a mass flow rate across the top of the rectangular window of approximately 0.0020 pounds mass per second.

After the probe was modified as discussed above, two more attempts were made to determine if the modifications had any effect on the problems discovered during the first examination. Both attempts failed to trigger the data acquisition program, the first due to a burst disk failure, and the second due to the fact that the combustion chamber pressure never reached the trigger value set for the data acquisition system.

C. TRANSMISSIVITY MEASUREMENTS

An examination of the transmittance through the probe body was then carried out. The stainless steel shims used to protect the windows were removed, cleaned, and a 0.20 inch diameter circular opening made in each. They were then

replaced, the probe mounted, and the He-Ne laser and photodiode mounted and aligned. This arrangement is shown in Figure 4.4.

The ejector flow was set to attain approximately 60 PSIA at the exhaust plane, and the window purge set as described above. Also, during this test firing, a second method of particle collection was attempted. This arrangement of the collection method is shown in Figure 4.5.

The data acquisition system was set to trigger at a pressure of 120 PSIA with a delay time on 0.2 seconds. The flow deflection device was again set to be activated for 0.5 seconds. The low smoke propellant used in this examination attained a chamber pressure of approximately 220 PSIA and burned for approximately 6.1 seconds. The composition of this propellant is shown in Table I.

Upon completion of the burn, the chart paper from the recorder was removed and examined. The transmittance through the probe dropped to approximately 35% after the deflection device was activated. This drop in transmittance occurred too rapidly for the chart recorder to make an accurate measurement. However, the reduced transmittance was attained in less than 250 milliseconds. After the deflection device was deactivated, the transmittance through the probe remained approximately 15% less than its initial value. The difference was attributed to deposition on the probe windows.

Examination of the stainless steel shim stock revealed deposition of exhaust particles had occurred on both windows. Some of the deposition downstream of the holes cut for the transmittance measurements was attributed to the edge of the opening in the shim stock itself. The circular window showed a line of deposits that began at the transmittance hole and gradually spread outward as it progressed downstream. The rectangular window had a deposition line across its entire surface which spread only after the transmittance hole. The upper surface of the rectangular window exhibited a slight but uniform covering of particles. As a result of this pattern the ejector flow for subsequent runs was increased.

The particles collected during this examination were prepared for use in the Mastersizer as discussed previously. The amount of collected particles proved to be insufficient for use in the Mastersizer system. The small number and size of the particles collected provided an obscuration for the Mastersizer laser beam which was below an acceptable level for accurate data collection. Future efforts will examine the collected particles using a scanning electron microscope.

D. TEST FIRING

After adjustment of the probe purge and ejector pressures, the system was configured for a test firing using a 16% aluminized propellant whose composition is listed in Table I.

A picture of the set up for this test firing was taken just before mounting of the motor and is enclosed as Figure 4.6. As can be seen in this figure, the probe was mounted to the Mastersizer enclosure and a self-vulcanizing rubber compound was used to seal the joint between the Mastersizer and the probe.

A graphite nozzle whose area ratio was 4.49 was used for this firing. The ejector purge was set for approximately 90 PSIA at the ejector exhaust plane, and the window purge was set as discussed above. The data acquisition system was set to trigger at a pressure of 100 PSIA, wait 0.5 seconds, trigger the flow deflection device, wait 0.3 seconds, trigger the Mastersizer to take its readings, and after another 0.3 seconds return the flow deflection device to the up position.

Before the actual firing, a background reading was taken and a sample measured with just the purge and ejector gases running. The sample data taken for this measurement is included as Figure 4.7. This figure shows a Gaussian distribution of light around the actual center of the detector array (out to diode number ten), and was caused by the underexpanded ejector flow in the field of view of the Mastersizer. This phenomenon is known as beam steering, and can be corrected for by disregarding the data detected by the affected diodes using the "killdata" Malvern software command. This approach, however, introduces another problem: that of

losing the data which would have been taken by these diodes. Most of the scattered light which would have been recorded by these rings (for the 100 mm lens used in this experiment) would be from particle sizes greater than approximately 26 microns. Particles this large are not often found in exhaust plumes. A second problem cause by beam steering is that the obscuration of a sample will be displayed as being artificially high. In this case the "apparent" obscuration caused by beam steering was 28%.

A further beam steering problem could be introduced by the temperature gradients between the hot exhaust gases and the cold ejector gases. There was no method available to accurately quantify this effect.

Upon completion of the beam steering experiment, the system was prepared and fired. A picture of the pressure and trigger traces for the run is included as Figure 4.8. The combustion chamber in the motor reached approximately 200 PSIA and the propellant burn plateau at this pressure lasted almost 6 seconds. Pictures of the run taken from the video record of the run are included as Figures 4.9 and 4.10. Figure 4.9 shows the run prior to the activation of the flow deflection device. As can be seen in the figure, the flow is being deflected above and past the tip of the probe. Figure 4.10 show the flow deflection device activated and the flow of the exhaust impinging on the probe tip.

A graph of the results of the Mastersizer measurements through the probe is included as Figure 4.11. As can be seen in this figure, the number distribution of particles was almost exclusively below 1.0 microns in size, although the volume distribution showed the presence of a few larger particles. The obscuration measurement for this test was approximately 47%, which was higher than that measured during the beam steering examination by a value which could reasonably be expected to allow for an accurate data representation to be made.

Upon completion of the run, a second sample measurement was taken to determine the amount of deposition on the windows of the probe. This data result is included as Figure 4.12. As can be seen in this data sample, deposition occurred to a degree which could reasonably be expected to affect the accuracy of the calculated distributions.

Disassembly of the probe mount and the probe showed that the deposition of particles occurred not inside the probe, but outside. The hot exhaust flow burned through the seal between the probe and the Mastersizer enclosure, allowing exhaust products to deposit on the Mastersizer lens and the outside of the rectangular window. After cleaning the lens and the outside of this window, an inspection of the inner window surfaces revealed that only a very small amount of the particulates had actually been deposited on the windows. The

circular window displayed a small amount of deposits in a thin line across the window, starting approximately half of the way across the window in the direction of flow. The rectangular window displayed a similar deposition, with no particulate matter deposited on the upper half of the window, which had been a problem in the previous runs.

The filter paper was recovered from the holder and dissolved in an acetone bath as discussed previously. The filter paper had not survived the test firing intact, but had been breached sometime during the run. The resulting sample proved once again to be too low in obscuration to allow for its analysis using the Mastersizer.

V. CONCLUSIONS AND RECOMMENDATIONS

The purpose of this investigation was to design a probe which could effectively be used to measure particle size distributions within the exhaust plume of a solid propellant rocket motor. The use of two separate methods was to allow for correlation between the two methods and to attempt to overcome the inherent shortcomings in each individual method. The probe design was only partially successful in accomplishing these objectives.

The filter paper mounted directly in the probe exit plane resulted in high back pressures in the probe. In order to obtain a sample for collection it was necessary to allow some of the flow exiting the probe to spill, thus allowing for loss of particles which had passed in front of the window and been measured by the Mastersizer. Also, some particles which had not passed through the probe could be entrained by the flow and collected.

The modifications made to the probe tip and ejector flow nozzle proved to be adequate to the task of keeping the windows clear of exhaust products. The small amount of deposition on the windows after the firing of this highly aluminized propellant suggests that it will indeed be possible to keep the windows clear during a test run under normal

circumstances. Future efforts will have to determine the effectiveness of the window purge system when the probe is positioned closer to the motor exhaust plane.

The ejector flow nozzle was modified after the window purge run, and no subsequent schlieren examination was undertaken to determine if the probe tip swallowed the shock formed at its tip. Examination of the video record of the test firing showed no shock to be visible during the time the flow was incident on the probe. In addition, tip suction was present when the ejector was in operation. Further investigation of this should be undertaken.

The problem of beam steering is one that could have a significant effect on the data taken using this method of particle sizing. The simple removal of the raw data affected by the beam steering causes the loss of any information for larger particles.

The particle collection probe designed for this experiment was successful in accomplishing the following tasks:

1. The data acquisition program adapted for this investigation proved capable of automating a test run and insuring that the data was collected.
2. The flow deflection device used in this investigation proved adequate for its purpose, which was to both protect the collection probe and insure that collection only took place during the steady-state portion of a firing.
3. The initial probe tip survived all test firings with no adverse effects while located approximately 14 nozzle exit diameters aft of the exhaust nozzle.

4. The window purge and ejector flow were adequate to maintain an acceptable level of window cleanliness.

5. The possibility of using the Mastersizer to examine in situ exhaust products was validated; the Mastersizer environment could be kept clean and the flow could be directed through the active volume without damage to the system.

The following recommendations are made for further experimentation with the probe and Mastersizer:

1. A complete investigation of the shock pattern around the tip of the collection probe must be undertaken to determine if the changes made to the ejector flow have had any effect on the shock swallowing capabilities of the tip. This should be accomplished for various positions behind the exhaust nozzle, and varying degrees of over- and under-expansion.

2. The probe must be tested in a range of over- and underexpanded flows to determine if the mass flow rate of the window purge is satisfactory for a variety of conditions.

3. A method of investigating the collected particles other than the Mastersizer should be included in any subsequent investigations. The Mastersizer's inability to handle low obscuration samples could be a hindrance to correlating the optical measurements with the collected particles.

4. A study of the mass flow rate requirements at the exhaust plane of the probe should be made to allow the design of a diffuser which would allow for closed system collection of exhaust constituents.

APPENDIX A
MASTERSIZER VALIDATION

The MALVERN Mastersizer is a particle sizing apparatus which uses the forward scattering of incident laser light to determine a particle distribution within the volume defined by the laser beam and the sample being investigated. Since this piece of equipment had not previously been utilized at NPS, a validation program was undertaken.

The first point examined was simply to determine if the Mastersizer properly sized particles of a known mean diameter. The importance of this point need not be belabored: if the Mastersizer could not properly identify particles of a known size, then no credence could be given to any information gathered on particles on unknown distributions.

The second topic concerned those particles in a distribution which were nominally below the resolution limit of a given lens. The question here was two-fold:

1. Do particles below the resolution limit affect the distribution which the Mastersizer calculates, and do they do so in a manner consistent with expectations?
2. If the particles below the resolution limit affect the distribution determined by the Mastersizer, is there a cutoff below which the Mastersizer cannot detect (or ignores) small particles in the calculation of its distributions?

The final topic dealt with the Mastersizer's ability to size small particles by using Mie theory corrections through the use of two user input parameters. In order to insure that the distributions determined by the Mastersizer algorithms were as close to the actual distributions as possible, it was necessary that some information on the sensitivity of the distributions to the changes in input parameters be determined.

Before any of these questions can be addressed, the user defined input parameters which allow the Mastersizer to make Mie theory corrections must be discussed. These two parameters are the differential refractive index (DRI) and the sample absorption index (Ua).

The optical qualities of any sample being examined become critical when the size of the particles involved approaches the wavelength of the incident light. The Mie theory of light scattering is a complete theory of light scattering from optically homogeneous spheres and requires assumptions concerning the optical nature of the particles and their surrounding medium.

In order to account for the refractive index of the particles and their surrounding medium, and the sample absorption, two parameters can be input into the Mastersizer. These parameters are the DRI, which is a ratio of the sample refractive index to that of the surrounding medium, and the

sample absorption index U_a . Certain discrete values of these properties are furnished with the Mastersizer.

A. SIZING OF KNOWN DISTRIBUTIONS

This part of the validation was carried out by using samples of polystyrene spheres of known sizes. The polystyrene spheres were dispersed in a distilled water medium and placed in a sample cell which contained a magnetic stirrer to insure that the sample remained uniform during the measurements. The spheres had a measured refractive index of 1.59 and were assumed to have an absorptive index of zero [Ref. 11]. The refractive index used for distilled water was 1.33. These values dictated a DRI of 1.20. The mean diameters of the known particles and the mean diameter calculated by the Mastersizer are shown in Table II.

Sample outputs of the Mastersizer for each of the sized particles are enclosed as Figures A.1 through A.3. As can be seen from Table II, the Mastersizer obtained diameters agreed very well with the diameters provided with the known particles, although it can be seen that as the resolution limit of the lens was approached calculated diameters were less accurate.

B. SUB-RESOLUTION LIMIT PARTICLES

This validation was carried out using samples of the 2.062 micron diameter micron polystyrene spheres. A measurement of

the sample distribution of these particles was taken with the Mastersizer, then particles of a diameter below the resolution limit of the lens were added and another measurement taken.

Comparisons of the mean diameters for these measurements are included as Table III. Note that the 0.364 and the 0.261 micron particles substantially affected the mean particle diameter calculated by the Mastersizer, while the 0.109 Micron particles had a negligible affect on the calculated diameter. Sample output plots for the three separate cases are shown in Figures A.4 through A.6. The information in these plots is presented in both volume and number distribution formats. These figures show clearly that for the 0.364 and the 0.261 micron particles, the number of particles measured in the sub-resolution range overwhelmed the number of 2.062 micron particles present in solution, although the majority of the volume of the distribution was taken up by the larger particles. For the sample containing the 0.109 micron particles, however, no number or volume distribution was shown for the smaller particles.

From the information in Table III it can be seen that the particles in the sub-resolution limit range and above approximately 0.25 microns have a substantial effect on the calculated mean diameter, while those in the 0.1 micron range have a negligible effect.

C. SENSITIVITY TO REFRACTIVE AND ABSORPTIVE INDICES

The sensitivity of the Mastersizer derived distributions to small changes in the differential refractive index (DRI) and the sample absorption index (U_a) is critical to its ability to properly size small particles. Although the DRI and U_a of aluminum oxide at room temperature are well characterized, this same information at the temperatures expected in the exhaust plume is not as well known [Ref. 12]. If the Mastersizer is too sensitive to small changes in these values, then it will be difficult to accurately size particles in the plume where the temperature can rapidly change.

A known distribution of polystyrene spheres was used in this investigation. The raw data collected from a measurement of the 2.062 micron spheres was reduced using a DRI of 1.70 and an absorption index of zero. These values were based on the work of Dobbins and Strand [Ref.12]. The plot of this result is shown in Figure A.7. The effects of the changes in DRI and U_a on the derived distribution are shown in Figures A.8 through A.11.

It can be seen from these plots that large shifts in the differential refractive index and sample absorption index can significantly effect the calculated distributions of the samples. However, for changes in the absorption index over the expected range for Al_2O_3 (Figures A.7 and A.8), there seemed to be negligible effect on the calculated distribution of

particles. This seems to indicate that the algorithm used by the Mastersizer is relatively insensitive to small changes in the sample absorption index, which was fortunate for this investigation. Since the expected value for the absorption index in the plume is somewhere between 1.0×10^{-4} and 1.0×10^{-7} [Ref. 13], the effect of small deviations from the specified absorption index on the calculated distributions should be small.

APPENDIX B

TABLES

TABLE I

PROPELLANT COMPOSITION
BY WEIGHT PERCENTAGE

Constituents	16% Alluminized	Reduced Smoke
Alluminum	16.00	
AP	69.85	82.00
R45M		8.85
RDX		4.00
Diocetyl Adipate		2.00
Ferric Oxide	0.15	
HB	14.00	
Zirconium Carbide		1.00
DDI		1.76
Other		0.39

TABLE II
SAMPLE VERSUS MEASURED MEAN
DIAMETERS FOR POLYSTYRENE SPHERES

Sample Mean (Microns)	Measured Mean (Microns)	Difference (Percent)
9.60	9.64	+0.42
2.062	2.11	+2.32
0.511	0.53	+3.72

TABLE III
 EFFECT OF SUB-RESOLUTION LIMIT PARTICLES
 ON BI-MODAL DISTRIBUTIONS

Sample Diameters (Microns)	Measured Mean Dia. (Microns)
2.062	2.01
2.062 + 0.364	0.57
2.062 + 0.261	0.49
2.062 + 0.109	1.96

APPENDIX C

FIGURES

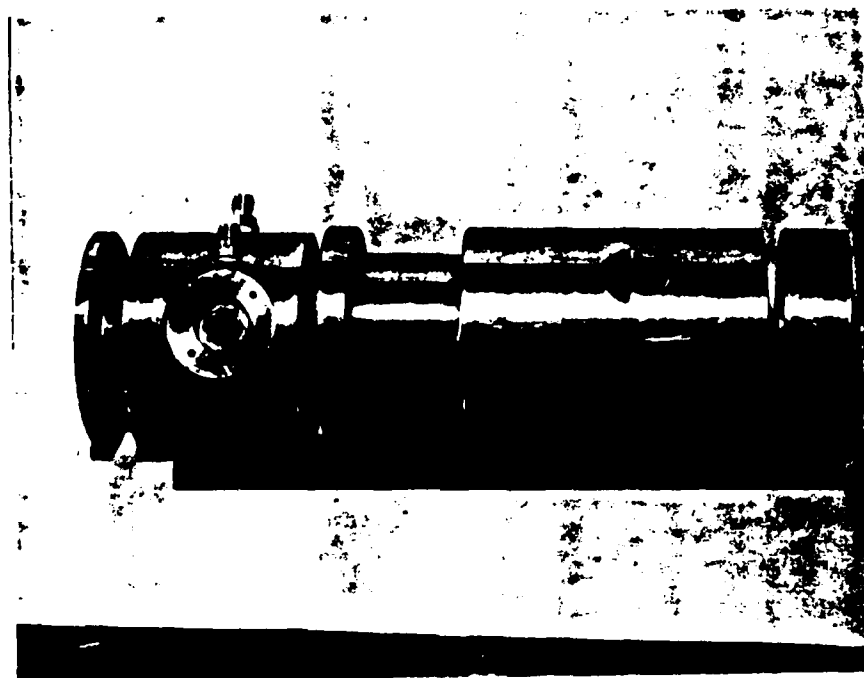

Figure 2.1 Three Dimensional Subscale Motor

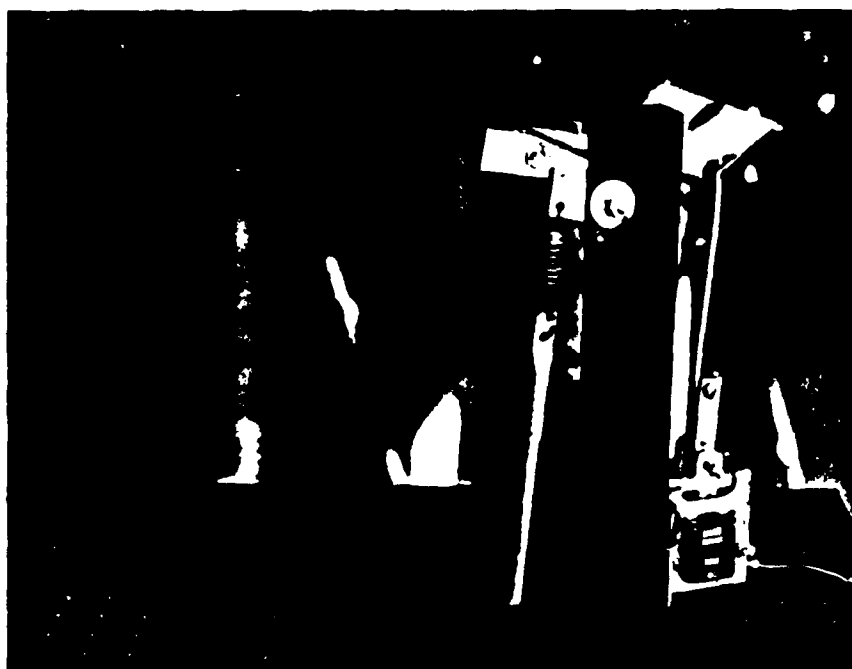

Figure 2.2 Flow Deflection Device

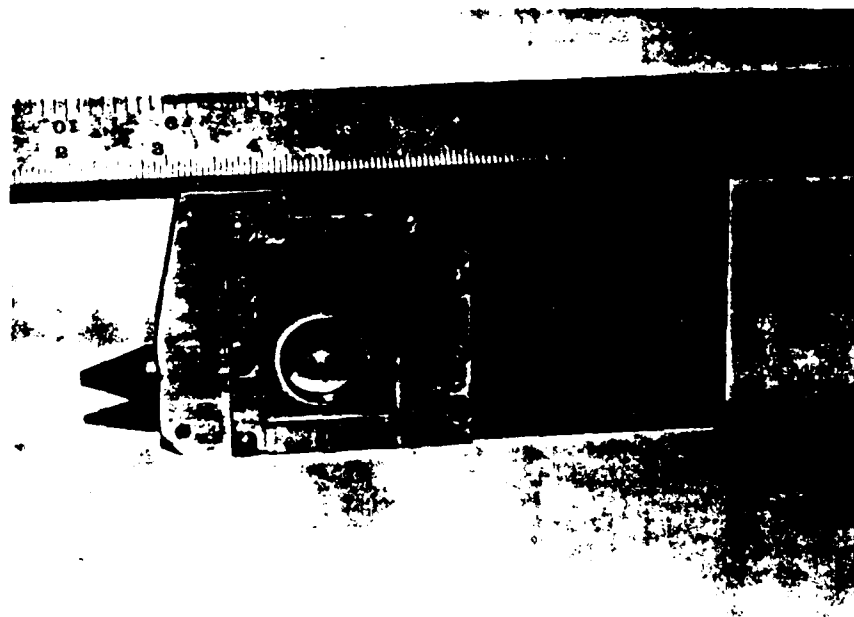

Figure 2.3 Particle Collection Probe

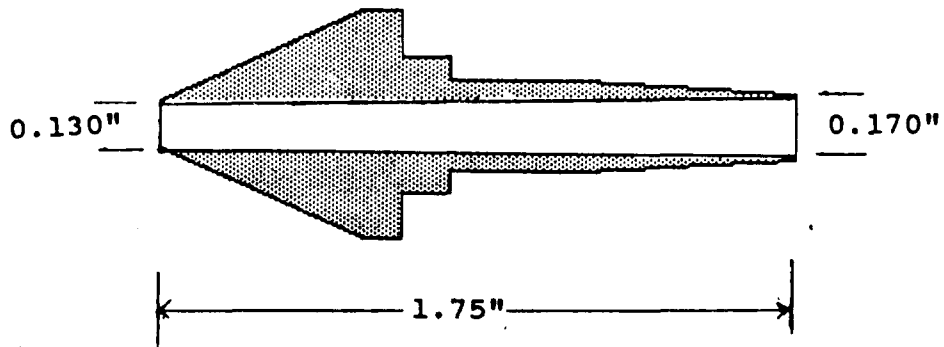

Figure 2.4 Cutaway View of Tip Interior

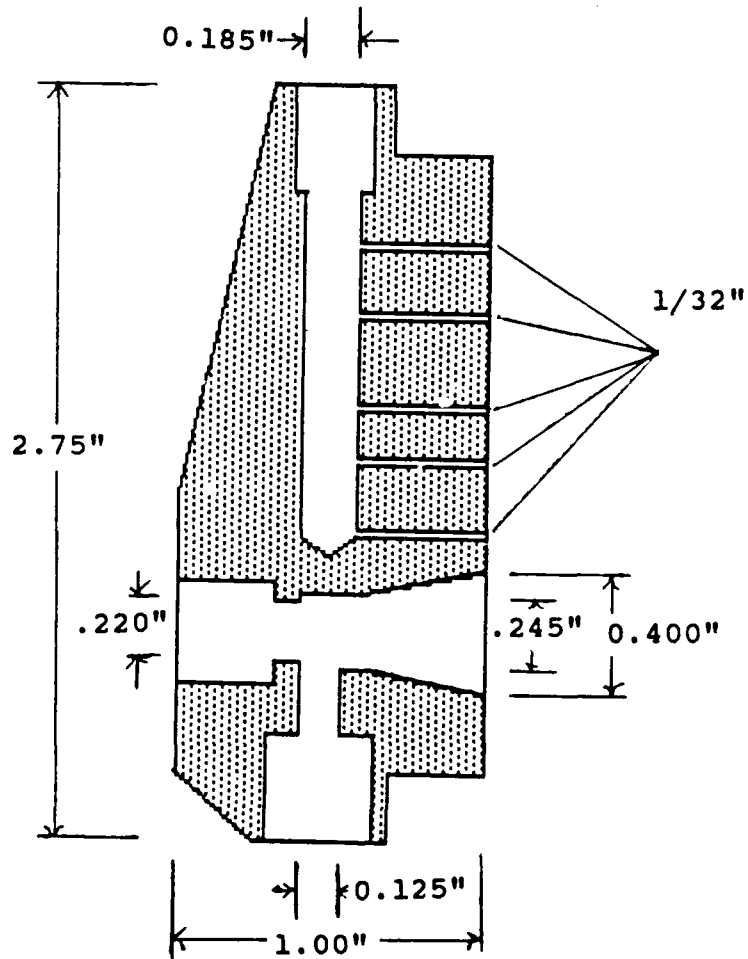

Figure 2.5 Cutaway View of Probe Head



Figure 4.1 Schlieren Experiment

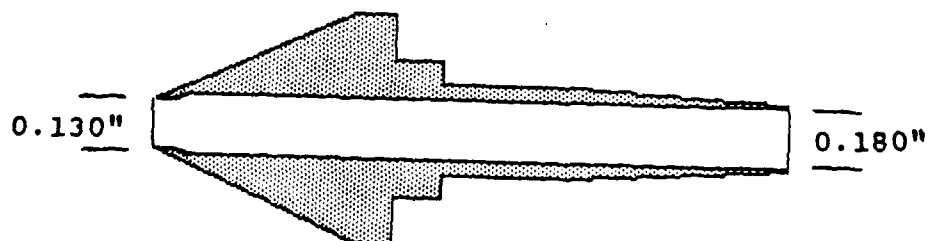

Figure 4.2 Cutaway View of Tip Modification

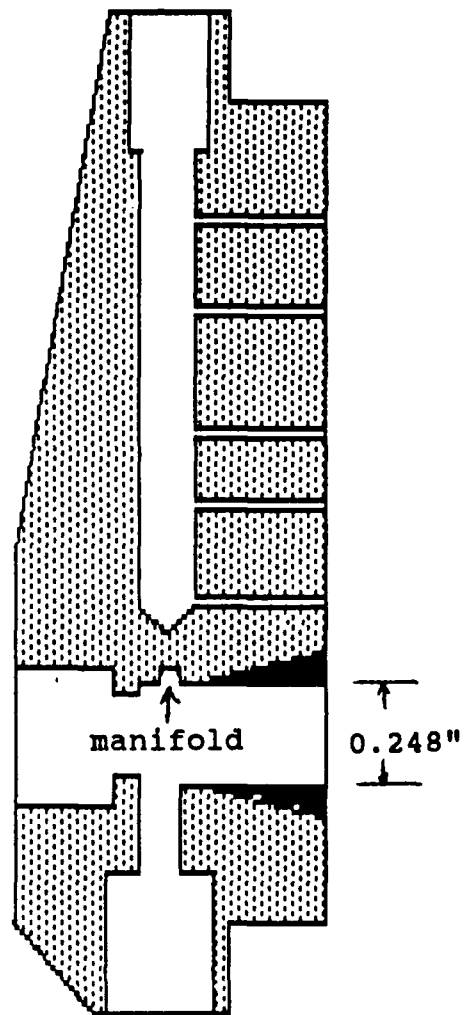

Figure 4.3 Cutaway View of Probe Head Modification

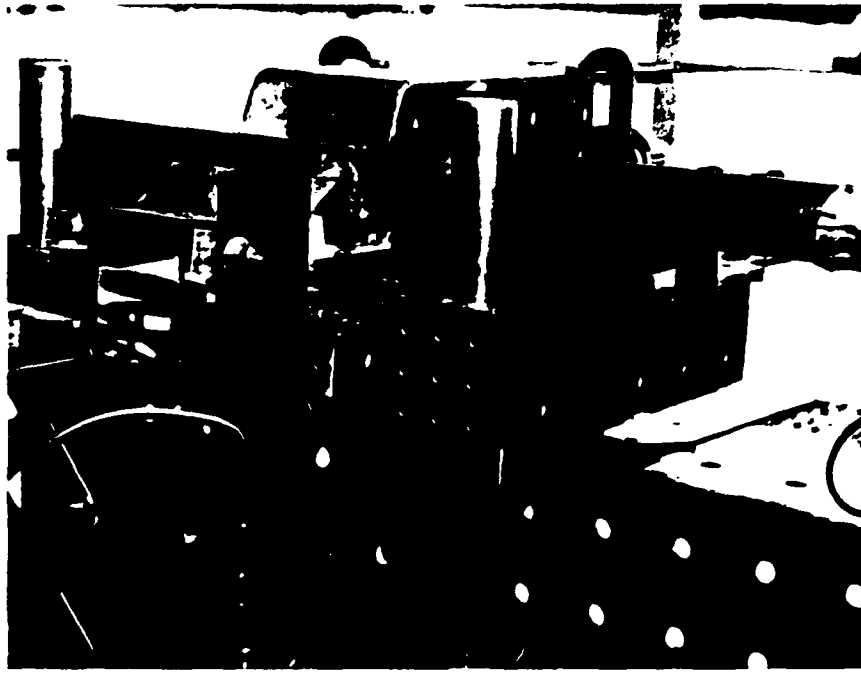

Figure 4.4 Transmittance Experiment



Figure 4.5 New Particle Collection Method

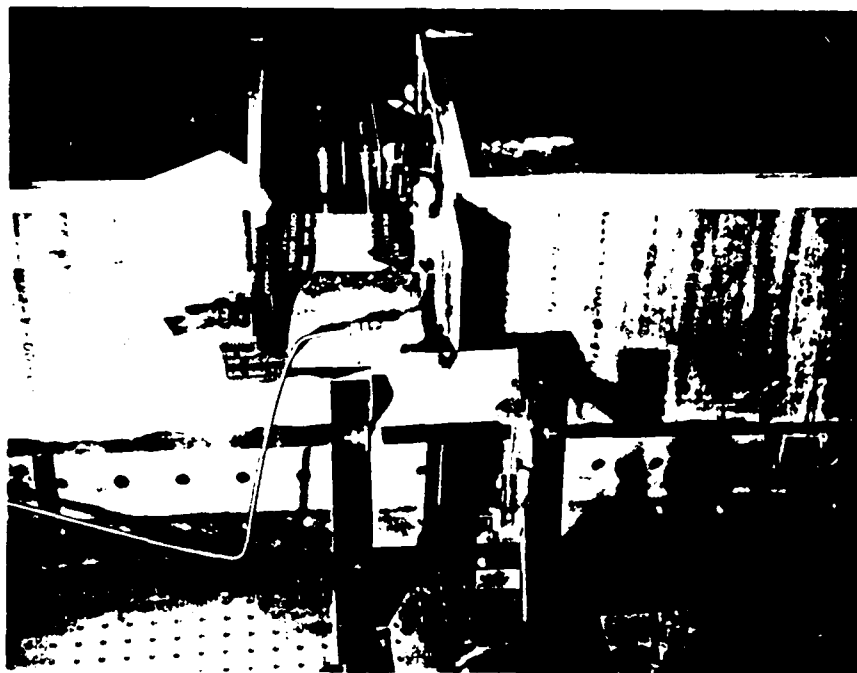

Figure 4.6 Test Firing Arrangement

Source Sample Record no. 8 1824
 Ring Data Focus 100

0	0.28	16	2.44
1	528.84	17	1.88
2	472.16	18	1.51
3	154.77	19	1.37
4	562.20	20	1.11
5	113.48	21	0.93
6	227.32	22	0.99
7	42.97	23	1.23
8	88.21	24	0.92
9	34.29	25	0.89
10	28.12	26	0.69
11	11.85	27	0.71
12	10.53	28	0.58
13	5.28	29	0.54
14	4.71	30	0.39
15	2.74	31	0.23

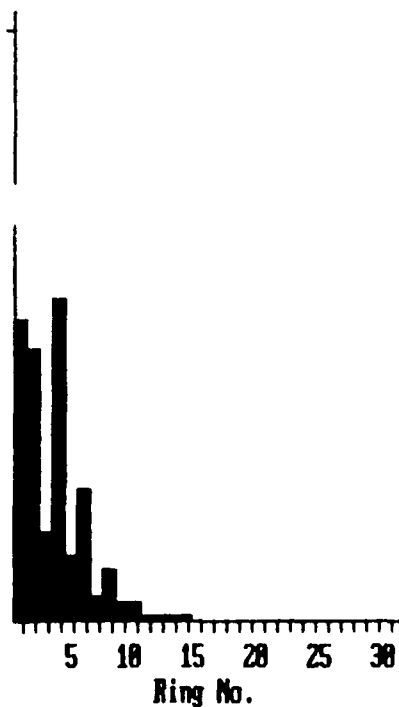

Figure 4.7 Effects of Beam Steering

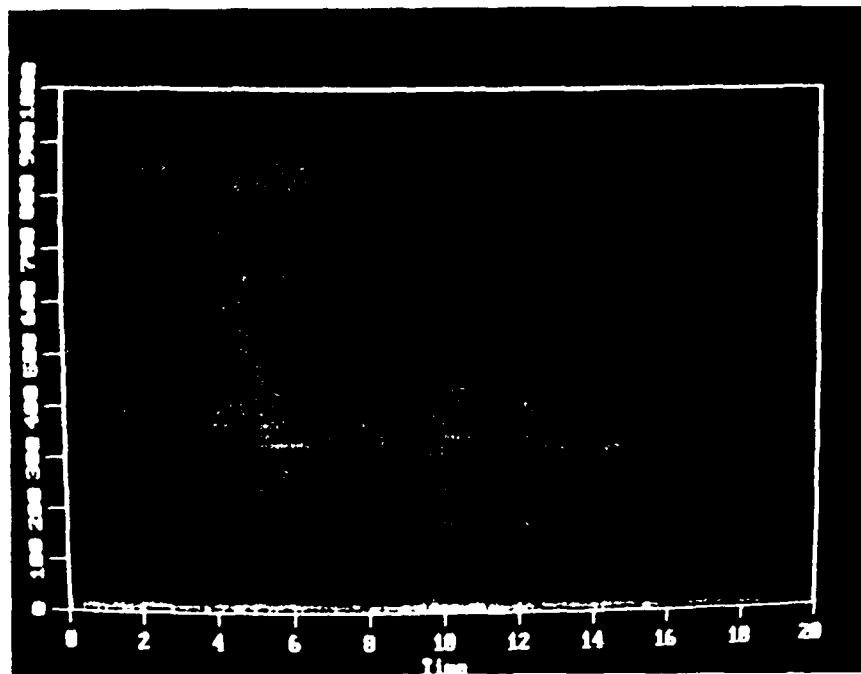

Figure 4.8 Test Firing Pressure-Time Trace



Figure 4.9 Test Firing - Before Deflector Activation

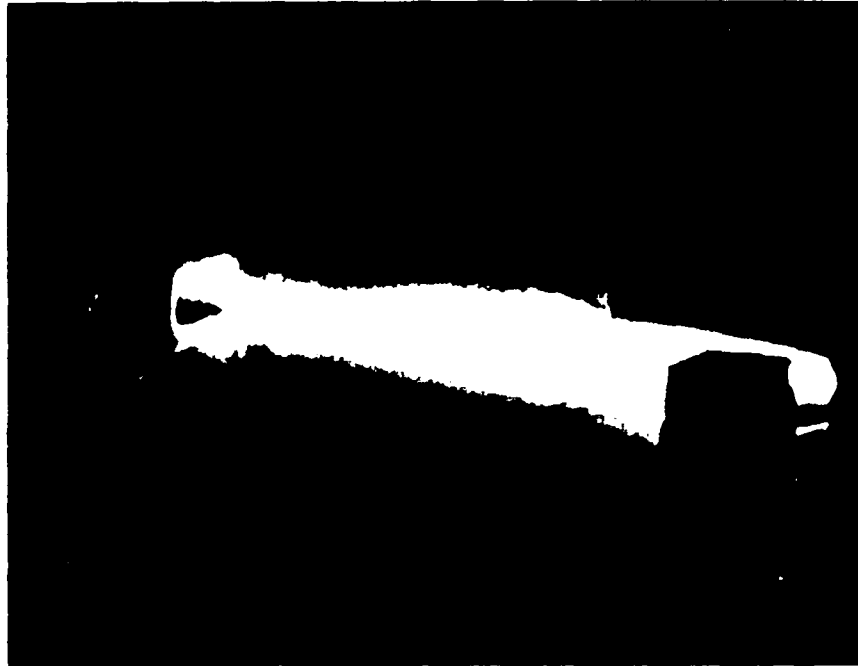

Figure 4.10 Test Firing - After Deflector Activation

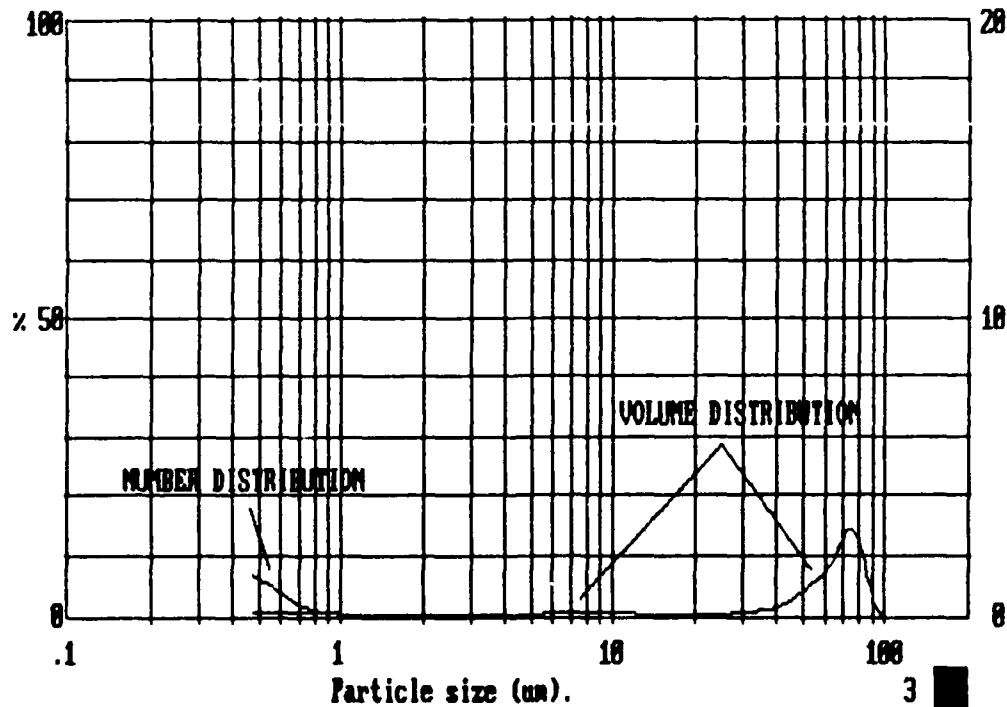

Figure 4.11 Mastersizer Results - Test Firing

Source B'ground Record no. 0 512
 Ring Data Focus 100

0	596.48	16	61.85
1	26.78	17	58.95
2	30.68	18	56.97
3	29.70	19	50.22
4	37.53	20	45.91
5	64.39	21	39.24
6	54.45	22	35.51
7	322.58	23	30.79
8	84.27	24	26.25
9	84.75	25	25.96
10	72.93	26	25.50
11	72.62	27	26.20
12	72.10	28	28.41
13	70.73	29	29.58
14	71.82	30	32.92
15	70.94	31	35.53

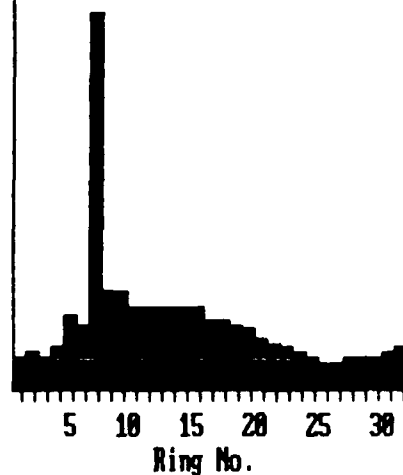

Figure 4.12 Window Obscuration

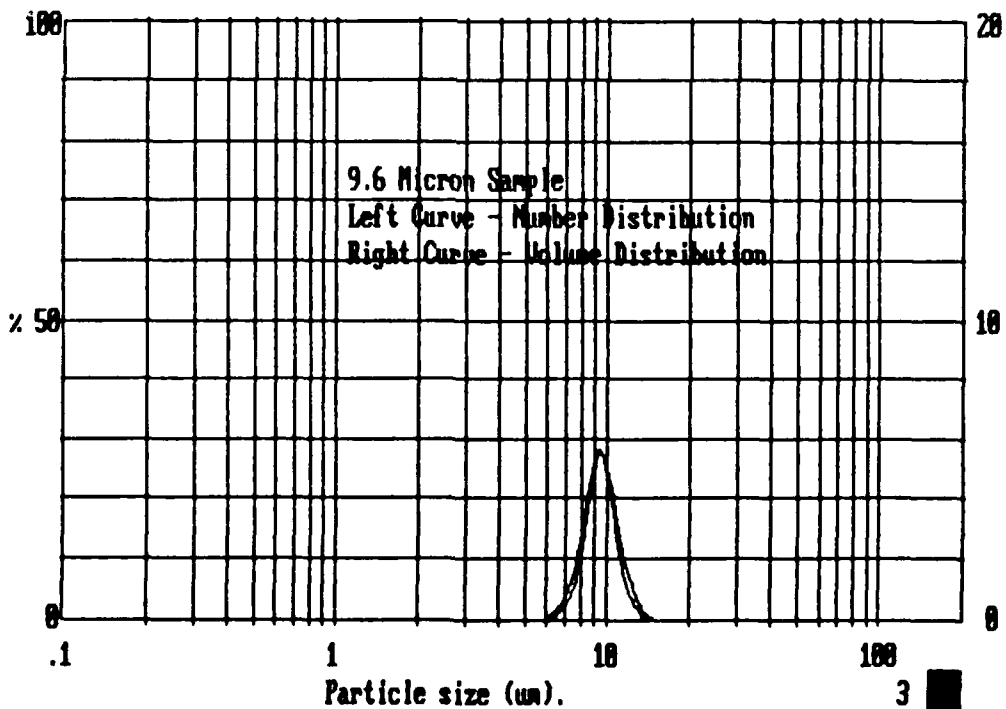

Figure A.1 Output for a Known Particle Diameter
 (9.6 Microns)

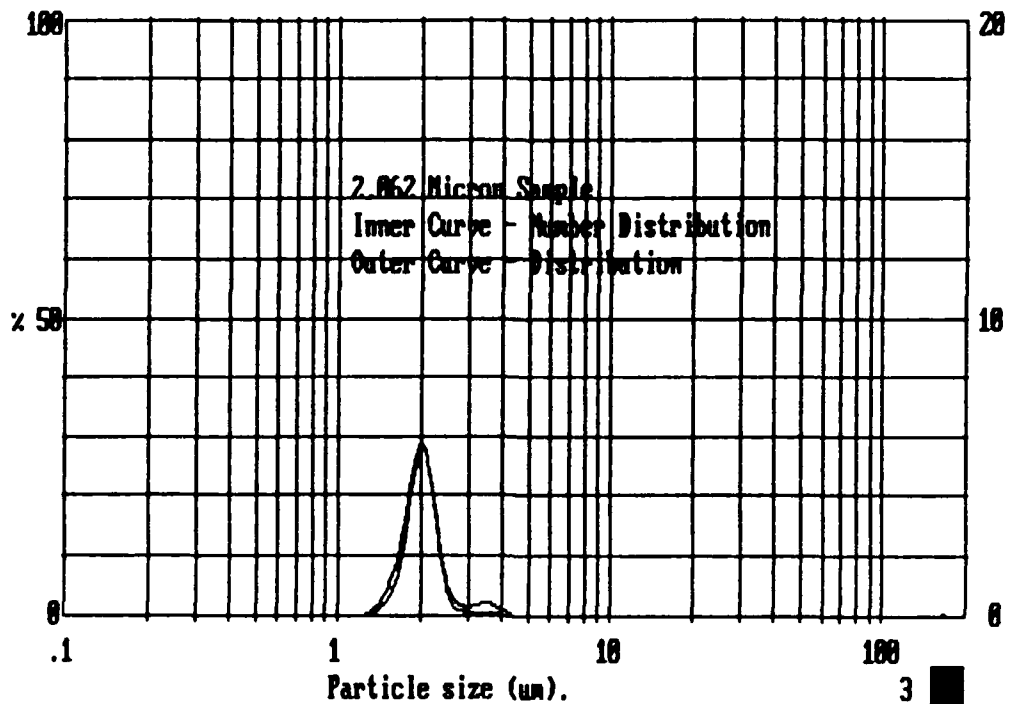

Figure A.2 Output For a Known Particle Diameter (2.062 Microns)

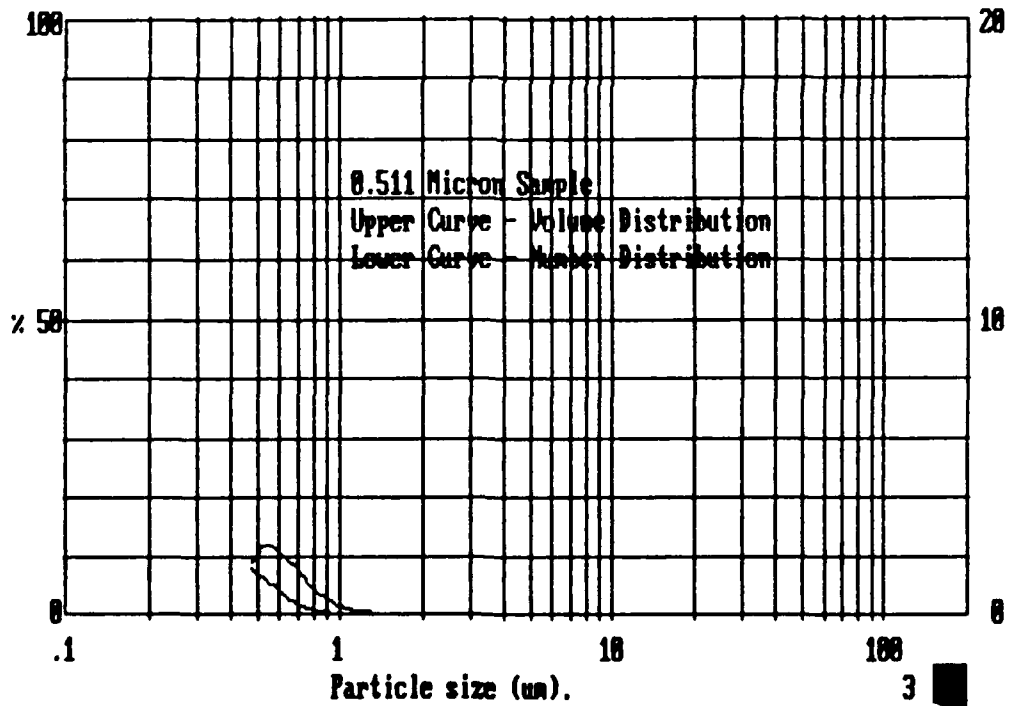

Figure A.3 Output for a Known Particle Diameter (0.511 Microns)

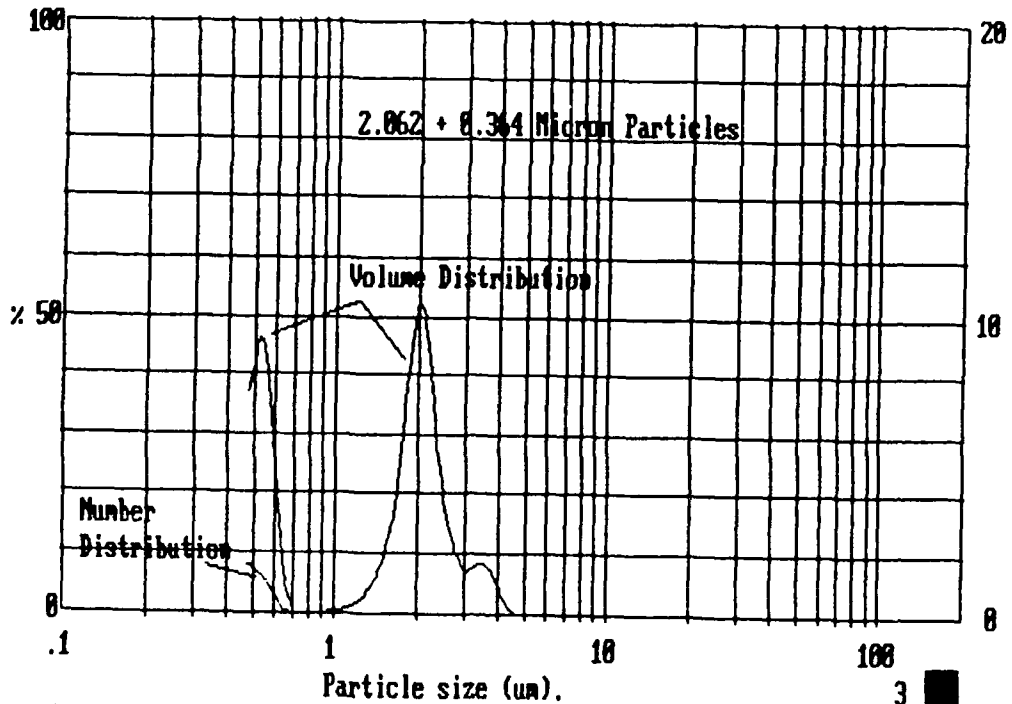

Figure A.4 Bi-Modal Sample (2.062 + 0.364 Microns)

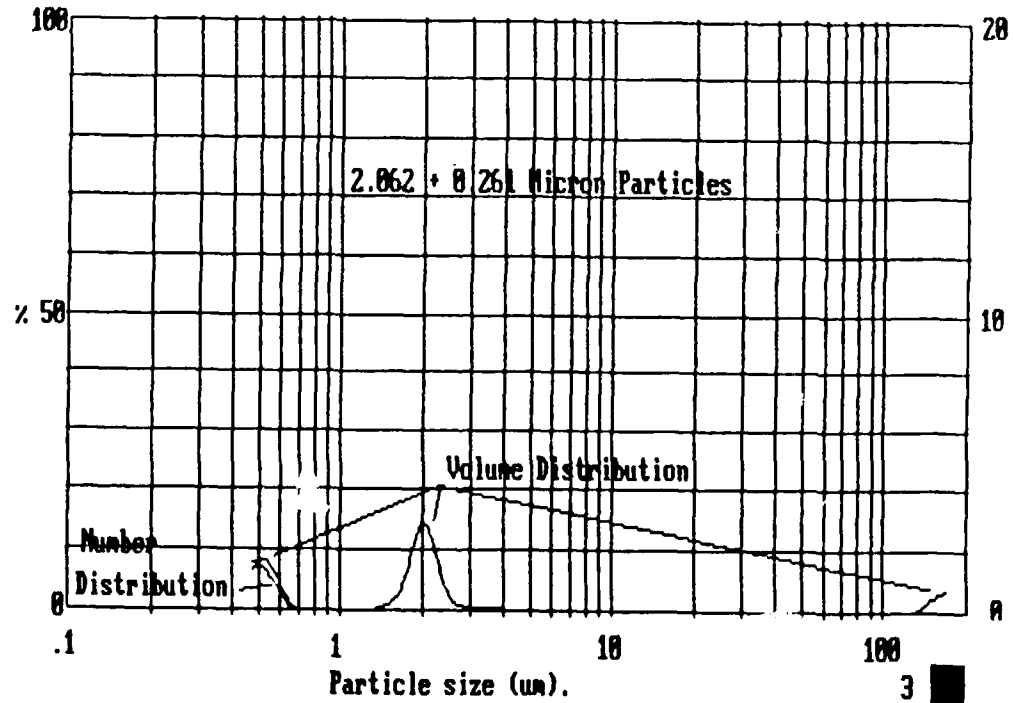

Figure A.5 Bi-Modal Sample (2.062 + 0.261 Microns)

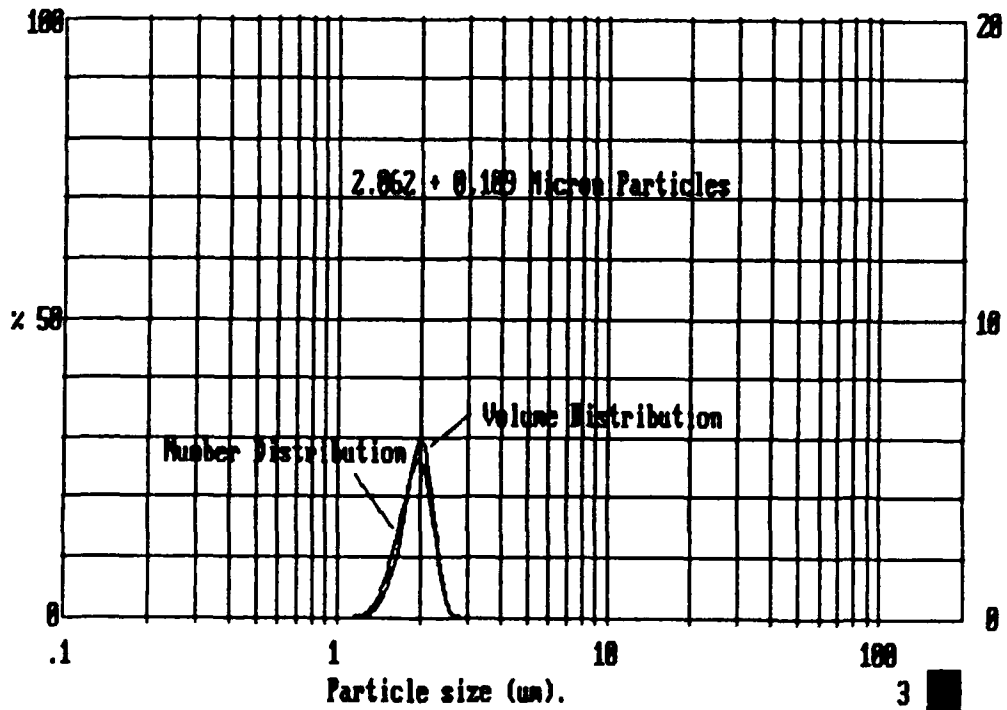

Figure A.6 Bi-Modal Sample (2.062 + 0.109 Microns)

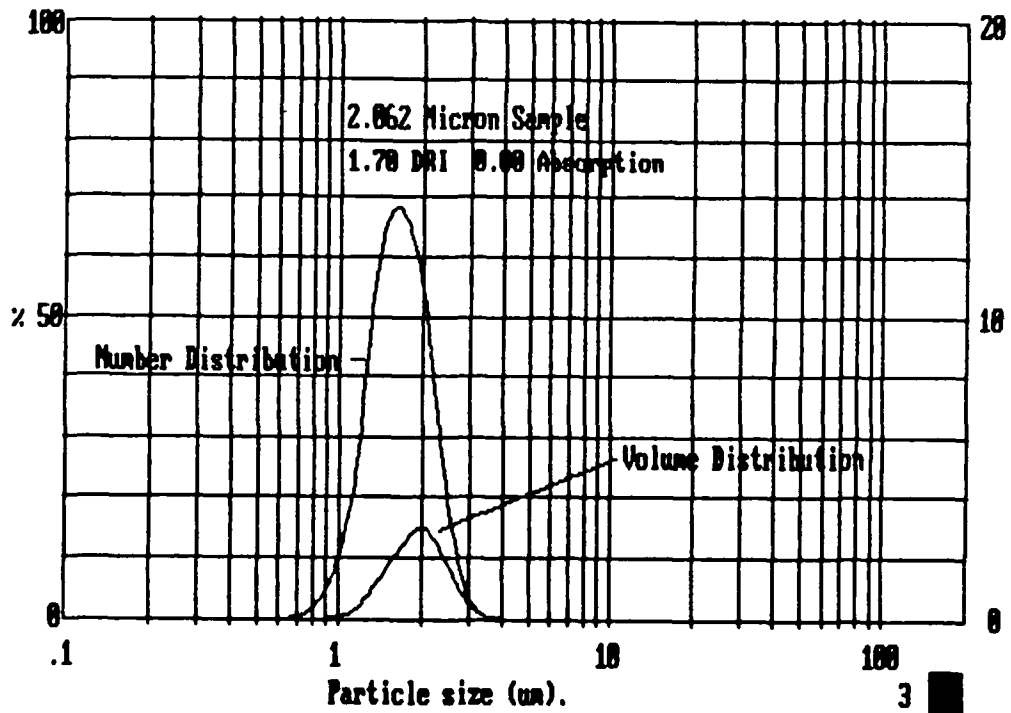

Figure A.7 Results for DRI of 1.70 and U_a of 0.00

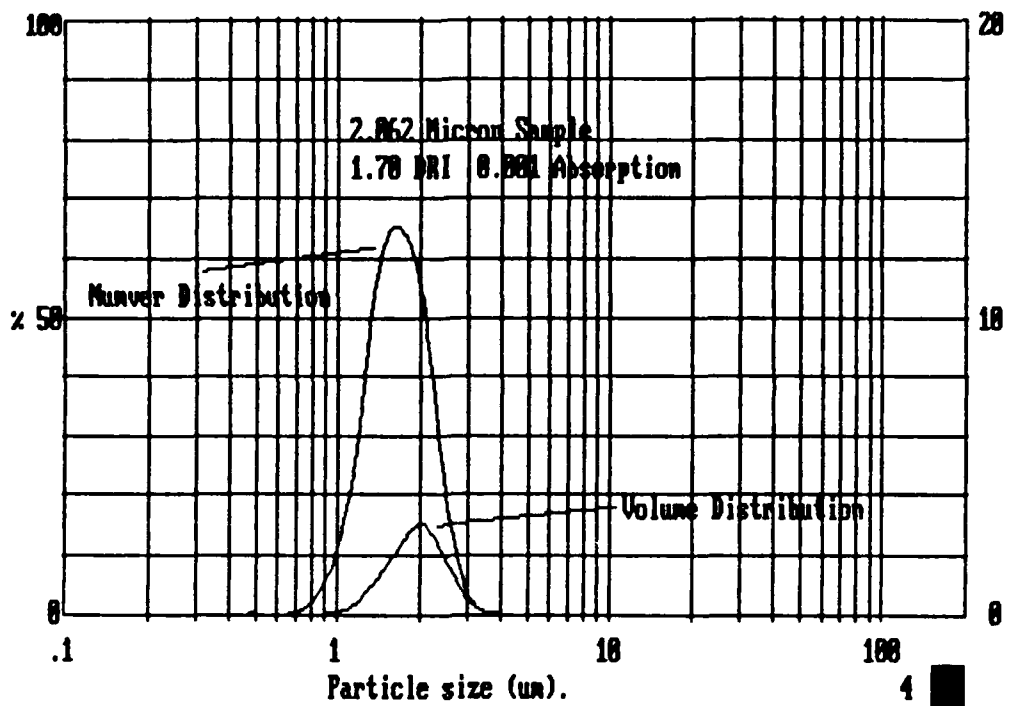

Figure A.8 Results for DRI of 1.70 and U_a of 0.001

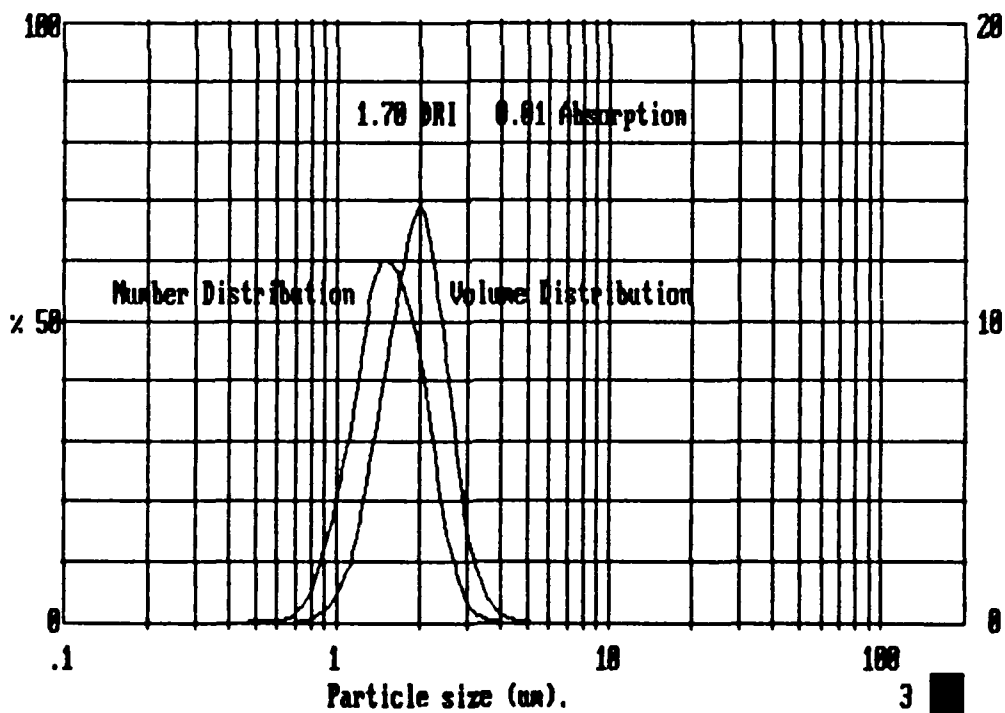

Figure A.9 Results for DRI of 1.70 and U_a of 0.01

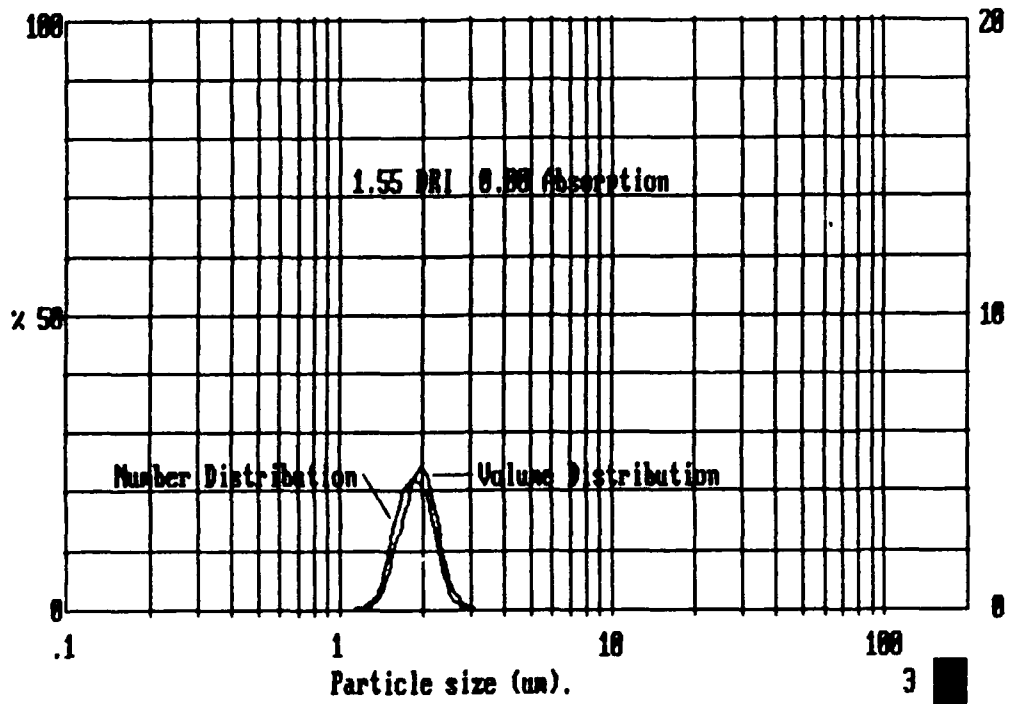

Figure A.10 Results for DRI of 1.55 and Ua of 0.00

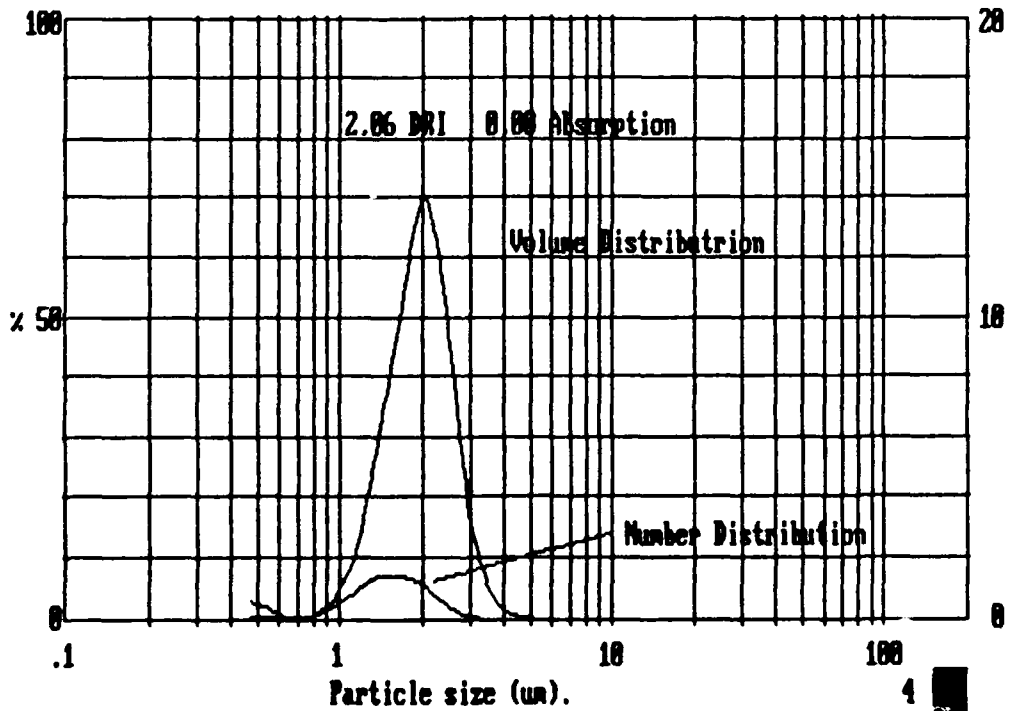

Figure A.11 Results for DRI of 2.06 and Ua of 0.00

LIST OF REFERENCES

1. Misener, J.A., and Kessel, P.A., "Current AFRPL Measurements and Characterization of Particulates in Solid Rocket Motor Plumes", 15th JANNAF Plume Technology Meeting, pp.275-284, CPIA Publication 426, May 1985.
2. Misener, J.A., and Kessel, P.A., "Plume Diagnostic Plans for Particulate Loaded Flows", Presented to TTCP Technical Panel W-4, 9th meeting, 25 October - 4 November 1983.
3. Pruitt, T. E., Measurement of Particle Size Distribution In a Solid Propellant Rocket Motor Using Light Scattering, Master's Thesis, Naval Postgraduate School, Monterey, California, June 1987.
4. Hovland, D.L., Particle Sizing in Solid Rocket Motors, Master's Thesis, Naval Postgraduate School, March 1989.
5. Youngborg, E.D., Application of Laser Diffraction Techniques to Particle Sizing in Solid Propellant Rocket Motors, Master's Thesis, Naval Postgraduate School, December 1987.
6. Walker, J.D., Holographic Investigation of Metallized Solid Propellant Combustion in Two Dimensional and Three Dimensional Rocket Motors, Master's Thesis, Naval Postgraduate School, September 1987.
7. Mastersizer Instruction Manual, Malvern Instruments LTD, Manual Version IM 100, Issue 2, August 1988, pp.1.27-1.32.
8. Smith, M. S., An Experimental Investigation in the Behavior of Metallized Solid Propellants, Master's Thesis, Naval Postgraduate School, December 1988.
9. Shapiro A.H. , The Dynamics and Thermodynamics of Compressible Fluid Flow, pp. 229 - 232, John Wiley and Sons, Inc., 1953.
10. Zucrow, M.J., and Hoffman, J.D., Gas Dynamics Volume I, p.712, John Wiley and Sons, Inc., 1976.

11. Application and Size Data, Sub-Micron Polystyrene Latex Kit, Duke Scientific Corporation, Palo Alto, California, May 1986.
12. Dobbins, R.A., and Strand, L. D., A Comparison of Two Methods of Measuring Particle Size of Al_2O_3 Produced by a Small Rocket Motor, AIAA Paper No. 69-146, AIAA 7th Aerospace Sciences Meeting, New York, New York, January 1969.
13. Calia, V., Konopka, W., Ryan, R., Celantano, A., and Soel, M., "Measurements of UV/VIS/LWIR Optical Properties of Al_2O_3 Rocket Propellant Particles", 18th JANNAF Exhaust Plume Technology Subcommittee Meeting, Monterey, CA., 14-17 November 1989.

INITIAL DISTRIBUTION LIST

	No. of Copies
1. Defense Technical Information Center Cameron Station Alexandria, Virginia 22304-6145	2
2. Library, Code 142 Naval Postgraduate School Monterey, California 93943-5002	2
3. Department Chairman, Code 67 Department of Aeronautics and Astronautics Naval Postgraduate School Monterey, California 93943-5004	1
4. Professor D.W. Netzer, Code 67NT Department of Aeronautics and Astronautics Naval Postgraduate School Monterey, California 93943-5004	2
5. CPT T.J. Eno 5344 Rt. 89 Romulus, New York 14541	2