

DTIC

2

NAVAL POSTGRADUATE SCHOOL  
Monterey, California

AD-A225 405



DTIC  
ELECTE  
AUG 17 1990  
S B D  
Co

THESIS

Development of a Laboratory Facility for  
the Measurement of Sound Propagation  
in Shallow Water Environments

by

Nakorn Pongsitanont

December, 1989

Thesis Advisors:

J. V. Sanders  
A. B. Coppens

Approved for public release; distribution is unlimited

90 0

UNCLASSIFIED

SECURITY CLASSIFICATION OF THIS PAGE

REPORT DOCUMENTATION PAGE			
1a REPORT SECURITY CLASSIFICATION		1b RESTRICTIVE MARKINGS	
2a SECURITY CLASSIFICATION AUTHORITY		3 DISTRIBUTION/AVAILABILITY OF REPORT	
2b DECLASSIFICATION/DOWNGRADING SCHEDULE		Approved for public release; distribution is unlimited.	
4. PERFORMING ORGANIZATION REPORT NUMBER(S)		5 MONITORING ORGANIZATION REPORT NUMBER(S)	
6a. NAME OF PERFORMING ORGANIZATION Naval Postgraduate School	6b. OFFICE SYMBOL (If applicable) Code 61	7a. NAME OF MONITORING ORGANIZATION Naval Postgraduate School	
6c ADDRESS (City, State, and ZIP Code) Monterey, CA 93943-5100		7b. ADDRESS (City, State, and ZIP Code) Monterey, CA 93943-5100	
8a NAME OF FUNDING/SPONSORING ORGANIZATION	8b OFFICE SYMBOL (If applicable)	9 PROCUREMENT INSTRUMENT IDENTIFICATION NUMBER	
8c ADDRESS (City, State, and ZIP Code)		10 SOURCE OF FUNDING NUMBERS	
		Program Element No	Project No
		Task No	Work Unit Accession Number
11. TITLE (Include Security Classification) DEVELOPMENT OF A LABORATORY FACILITY FOR THE MEASUREMENT OF SOUND PROPAGATION IN SHALLOW WATER ENVIRONMENT			
12. PERSONAL AUTHOR(S) Pongsitanont, Nakorn.			
13a. TYPE OF REPORT Master's Thesis	13b TIME COVERED From To	14 DATE OF REPORT (year, month, day) 1989, December	15 PAGE COUNT 85
16. SUPPLEMENTARY NOTATION The views expressed in this thesis are those of the author and do not reflect the official policy or position of the Department of Defense or the U.S. Government.			
17 COSATI CODES		18. SUBJECT TERMS (continue on reverse if necessary and identify by block number)	
FIELD	GROUP	Sound Pressure Field, Speed of Sound in Water-Saturated Sand, Normal-Mode Cutoff Frequency	
19 ABSTRACT (continue on reverse if necessary and identify by block number)			
<p>The Propagation of sound in a laboratory-modeled, shallow water environment consisting of water overlying a thick layer of water saturated sand was experimentally investigated. A hydrophone consisting of a small lead titanate lead zirconate cylinder was used as a receiver. A 304x117x95 cm fiberglass-encased wooden tank a 10 cm layer of water overlying a 45 cm layer of water saturated sand was used in this experiment. The receiver sensitivity and directionality were determined for frequencies from 10 kHz to 100 kHz. The ratio of the speed of sound in the water-sand to that in water was 1.2 and the ratio of the densities was 2.05. The measured normal incidence pressure reflection coefficient was within 12.8% of the predicted value. The measurements of pressure amplitude in the water as a function of depth were found to be in good agreement with normal mode theory for the first mode, but slight unexplained differences were observed for the sum of the first and second modes. The apparatus developed for this thesis has been shown to accurately model sound propagation in shallow water with a flat sandy bottom and is now available for the study of more complicated bottom topographies.</p>			
20. DISTRIBUTION/AVAILABILITY OF ABSTRACT		21. ABSTRACT SECURITY CLASSIFICATION	
<input checked="" type="checkbox"/> UNCLASSIFIED/UNLIMITED <input type="checkbox"/> SAME AS REPORT <input type="checkbox"/> DTIC USERS		Unclassified	
22a NAME OF RESPONSIBLE INDIVIDUAL Prof. J. V. Sanders		22b TELEPHONE (Include Area code) (408) 646-2931	22c OFFICE SYMBOL Code 61Sd

DD FORM 1473, 84 MAR

83 APR edition may be used until exhausted  
All other editions are obsolete

SECURITY CLASSIFICATION OF THIS PAGE  
Unclassified

Approved for public release; distribution is unlimited.

Development of a Laboratory Facility for  
the Measurement of Sound Propagation  
in Shallow Water Environment

by

Nakorn Pongsitanont  
Commander, Royal Thai Navy  
B.S., Royal Thai Navy Academy, 1975

Submitted in partial fulfillment  
of the requirements for the degree of

MASTER OF SCIENCE IN ENGINEERING ACOUSTICS

from the

NAVAL POSTGRADUATE SCHOOL  
December 1989

Author:



Nakorn Pongsitanont

Approved by:

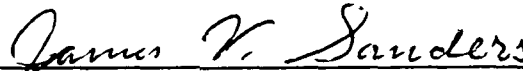

James V. Sanders, Thesis Advisor



Alan B. Coppens, Thesis Advisor

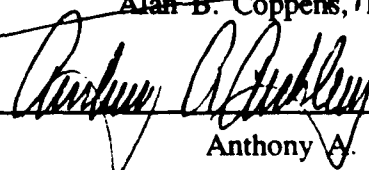

Anthony A. Atchley

Chairman, Engineering Acoustics Academic Committee

**ABSTRACT**

The propagation of sound in a laboratory-modeled, shallow water environment consisting of water overlying a thick layer of water-saturated sand was experimentally investigated. A hydrophone consisting of a small lead-titanate lead-zirconate cylinder was used as a receiver. A 304x117x95 cm fiberglass-encased wooden tank with a 10 cm layer of water overlying a 45 cm layer of water-saturated sand was used in this experiment. The receiver sensitivity and directionality were determined for frequencies from 10 kHz to 100 kHz. The ratio of the speed of sound in the water-sand to that in water was 1.2 and the ratio of the densities was 2.05. The measured normal-incidence pressure reflection coefficient was within 12.8% of the predicted value. The measurements of pressure amplitude in the water as a function of depth were found to be in good agreement with normal mode theory for the first mode, but slight unexplained differences were observed for the sum of the first and second modes. The apparatus developed for this thesis has been shown to accurately model sound propagation in shallow water with a flat sandy bottom and is now

For

in

Availability Codes

Dist Avail and/or Special

A-1

available for the study of more complicated bottom  
topographies.

**TABLE OF CONTENTS**

I. INTRODUCTION . . . . . 1

II. EXPERIMENTAL DESIGN . . . . . 3

    A. HYDROPHONE . . . . . 3

        1. Hydrophone Construction . . . . . 3

        2. Hydrophone Sensitivity . . . . . 4

        3. Hydrophone Calibration . . . . . 5

            a. Free Field Sensitivity Response . . . . . 5

        4. Directivity Pattern of Hydrophone . . . . . 10

            a. Horizontal Pattern . . . . . 10

            b. Vertical Pattern . . . . . 10

    B. TANK TEST PREPARATION . . . . . 11

III. RESULTS . . . . . 15

    A. DENSITY . . . . . 15

        1. Water-Saturated Sand . . . . . 15

        2. Water . . . . . 15

    B. SOUND SPEED . . . . . 16

        1. Water-Saturated Sand . . . . . 17

            a. Theoretical Sound Speed in Water-Saturated  
            Sand . . . . . 17

b. Measurement of the Sound Speed in Water-	
Saturated Sand . . . . .	19
2. Water . . . . .	20
C. REFLECTION COEFFICIENT OF WATER-SATURATED SAND	23
D. NORMAL-MODE CUTOFF FREQUENCY . . . . .	27
E. SOUND PRESSURE AS FUNCTION OF RECEIVER DEPTH OVER	
A FLAT BOTTOM . . . . .	28
1. Theory . . . . .	28
2. Sound Pressure Measurement . . . . .	30
IV. CONCLUSIONS . . . . .	34
LIST OF REFERENCES . . . . .	73
INITIAL DISTRIBUTION LIST . . . . .	74

## List of Figures

Figures	Description	Pages
1.	Construction of Hydrophone . . . . .	36
2.	LC-10 Far Field Frequency Response Curve . . . . .	37
3.	Calibration of Hydrophone by Direct Comparison Method . . . . .	38
4.	Hydrophone No.1 Far Field Frequency Response Curve . . . . .	39
5.	Hydrophone No.2 Far Field Frequency Response Curve . . . . .	40
6.	Horizontal Directivity Pattern of Hydrophone No.1, 30 kHz. . . . .	41
7.	Horizontal Directivity Pattern of Hydrophone No.1, 50 kHz. . . . .	42
8.	Horizontal Directivity Pattern of Hydrophone No.1, 80 kHz. . . . .	43
9.	Horizontal Directivity Pattern of Hydrophone No.1, 100 kHz. . . . .	44
10.	Horizontal Directivity Pattern of Hydrophone No.2, 30 kHz. . . . .	45

Figure	Description	Pages
11.	Horizontal Directivity Pattern of Hydrophone No.2, 40 kHz. . . . .	46
12.	Horizontal Directivity Pattern of Hydrophone No.2, 80 kHz. . . . .	47
13.	Horizontal Directivity Pattern of Hydrophone No.2, 100 kHz. . . . .	48
14.	Vertical Directivity Pattern of Hydrophone No.1, 30 kHz. . . . .	49
15.	Vertical Directivity Pattern of Hydrophone No.1, 50 kHz. . . . .	50
16.	Vertical Directivity Pattern of Hydrophone No.1, 80 kHz. . . . .	51
17.	Vertical Directivity Pattern of Hydrophone No.1, 100 kHz. . . . .	52
18.	Vertical Directivity Pattern of Hydrophone No.2, 30 kHz. . . . .	53
19.	Vertical Directivity Pattern of Hydrophone No.2, 40 kHz. . . . .	54
20.	Vertical Directivity Pattern of Hydrophone No.2, 80 kHz. . . . .	55

Figures	Description	Pages
21.	Vertical Directivity Pattern of Hydrophone No.2, 100 kHz. . . . .	56
22.	Eliminating Air Bubbles in the Water-Sand Mixture	57
23.	Measurement of the Speed of Sound in Water-Sand Mixture & Water . . . . .	58
24.	Measurement of the Speed of Sound in Water with a Velocimeter . . . . .	59
25.	Measurement of the Reflection Coefficient of Water- Sand Mixture . . . . .	60
26.	Reflected Waveform a) Water-Air b) Water-Sand	61
27.	Theoretical & Experimental Normal-Mode Cutoff Frequency, First Mode . . . . .	62
28.	Sound Pressure in Water Layer, 9.5 kHz. . . . .	63
29.	Sound Pressure in Water Layer, 15 kHz. . . . .	64
30.	Sound Pressure in Water Layer, 18 kHz. . . . .	65
31.	Sound Pressure in Water Layer, 20 kHz. . . . .	66
32.	Sound Pressure in Water Layer, 30 kHz. . . . .	67
33.	Sound Pressure in Water Layer, 35 kHz. . . . .	68
34.	Sound Pressure in Water Layer, 40 kHz. . . . .	69

Figures	Description	Pages
35.	a) Position of Hydrophone for Vertical Directivity Pattern Measurement. b) Aluminum Blade . . . . .	70
36.	Equipment Set Up for the Measurement of the Sound Pressure in Water Layer . . . . .	71
37.	Speed of Sound in Water vs Hydrophone Distance .	72

## I. INTRODUCTION

The propagation of sound in shallow water is a complicated problem. The reflection of sound between water surface and bottom has to be considered, so there is considerable phase interference among the various multipaths. The surface has a pressure reflection coefficient close to unity in magnitude, while the reflection coefficient from the bottom depends on the nature of the bottom. Transmission of sound in shallow water also depends on the depth of water and roughness and slope of the bottom. To predict the sound field, both ray and normal mode theory have been applied. Ray theory has limited application, especially in shadow zone and can not be used for low frequency when the wavelength of sound becomes comparable with the vertical scale of the sound speed variation.

Normal mode theory is more applicable and also more complicated. Normal mode theory provides an exact solution to the wave equation so it can be used in all cases. In 1984, Tariq and Rungsirotekomol [Ref. 1] studied and did experiments on the propagation of sound in a shallow water model. They used "Celesco LC-5s", as sound source and receiver. The LC-5 omni-directional hydrophone is consisted of a 0.16 cm

diameter by 0.32 cm long barium titanate cylinder. A typical sensitivity of the LC-5 is -224 dB re 1V/uPa. They measured the sound field both in the water layer and in the sand bottom as a function of depth only for the first normal mode. Their results agreed well with the theoretical model.

The purpose of this research is to make a hydrophone smaller than the LC-5 and determine its properties, such as far field frequency response and directivity patterns for both horizontal and vertical. Then this hydrophone will be used to investigate the propagation of sound in a water layer for the first and second normal modes. Results will be compared with the theoretical model. In this study, the bottom and water surface will be flat. The speed of sound in the water layer and in the sand-water mixture will be measured as will be the reflection coefficient from bottom.

## II. EXPERIMENTAL DESIGN

### A. HYDROPHONE

#### 1. Hydrophone Construction

Two hydrophones were made by using a small lead-titanate lead-zirconate cylinder of piezoelectric ceramic which was manufactured by CHANNEL, channel 5700. The dimensions of the cylinders are 0.06 inches in outside diameter, 0.125 inches in length and 0.005 inches in thickness. They are radially polarized. Figure 1 shows the construction of the hydrophones. At one end of a co-axial cable, the jacket and shield were peeled off about 1 cm and about 0.3 cm of inner insulator was cut away. The ceramic was connected to the co-axial cable by putting the inner conductor of the cable into the cylinder. To make a good electrical contact between conductor and inner surface of ceramic, a small amount of silver paint was applied at the tip of inner conductor before connecting. Since the inner diameter of ceramic is small, the ceramic is held to the cable by friction. To make a strong water-resistant, connection between the cable and ceramic, a small amount of epoxy was applied at the both ends of ceramic. To prevent damaging the ceramic, the outer surface

of the ceramic was connected to the shield of the co-axial cable by soldering with the lowest temperature and shortest time as possible. Finally, the ceramic was cleaned with solvent and rubber paint applied to prevent electrical short circuit while doing experiments in water. The other end of co-axial cable was cut at 1 meter away from ceramic end and a BNC connector was connected to this end.

## 2. Hydrophone Sensitivity

The open-circuit sensitivity of a radially-polarized piezoelectric cylinder ceramic is [Ref. 2]:

$$M_o = 2bg_{31}\left\{\left(\frac{1}{2}\right)\left[\frac{(2+\beta)}{(1+\beta)} + \frac{g_{33}(1-\beta)}{g_{31}(1+\beta)}\right]\right\},$$

for capped ends, and

$$M_o = 2bg_{31}\left\{\left(\frac{1}{2}\right)\left[(2-\beta) + \frac{g_{33}(1-\beta)}{g_{31}(1+\beta)}\right]\right\},$$

for exposed ends,

where  $M_o$  = open-circuit sensitivity,

$b$  = ratio of the outer to the inner radius of the cylinder,

$\beta$  = ratio of inner and outer diameter of the cylinder,

$g_{31}$  = static voltage output coefficient due to  
force acts along the cylinder,

$g_{33}$  = static voltage output coefficient due to  
force acts in radial direction.

Because of the construction of these hydrophones, they can be considered as having exposed ends. The static voltage output coefficient,  $g_{31}$  and  $g_{33}$ , are given by [Ref. 4], to be

$$g_{31} = - 0.0088 \text{ Vm/N,}$$

$$g_{33} = + 0.0194 \text{ Vm/N.}$$

The ratio of the inner diameter and outer diameter,  $\beta$ , is 0.92. The radius of cylinder,  $b$ , is 0.0762 cm. Substitution of these values into the previous equation gives the open-circuit sensitivity,  $M_{ox} = 6.75 \times 10^{-6} \text{ V/Pa}$  or -223.5 dB re 1V/ $\mu$ Pa.

### 3. Hydrophone Calibration

#### a. Free Field Sensitivity Response

Techniques for obtaining the sensitivity of a hydrophone are of two types: absolute and relative. Since there was a receiver of known sensitivity on hand, an LC-10 serial No. A-726 with calibration curve as shown in Figure 2, it was convenient to use the direct comparison technique to determine free field sensitivity response of these hydrophones.

Figure 3 shows the set up for measuring the sensitivity of the hydrophones. The 1.85x7.2x2.3 m anechoic test tank in S-025 Spanagel Hall, Naval Postgraduate School, was used for this calibration. A USRD F27 No. 82 was used as a sound source. The procedure of calibration was as follows:

First, the LC-10 of known sensitivity was placed in the water a depth of 1.00 m. The source was placed at the same depth 1.50 m from the receiver along the center line of the tank. The desired frequency signals were generated by a continuous wave signal generator, Wavetek model 116, passed to tone burst generator, General Radio type 1396-A, with 32 cycles opened and 128 cycles closed, and was amplified by power amplifier, HP-465A, before arriving at the USRD F27 sound source. The received signal from the reference hydrophone was passed to a SKL model 302 filter and was amplified by 60 dB by a HP-467A pre-amplifier. The bandwidth of the filter was set to 15 kHz to 20 kHz as shown in table 2.1 and 2.2. The pulse amplitude of the received signal which was the CW signal of 2.0 kHz steps were determined and recorded as function of frequency from an oscilloscope (COS-5060). The useful frequency range of the reference hydrophone, LC-10, is 10 kHz to 100 kHz. This range of frequencies was used for this calibration.

TABLE 2.1  
Free field frequency response  
Hydrophone No.1

Frequency kHz.	Bandwidth kHz.	Amplitude mV	dB V/ $\mu$ Pa.
10	5-20	24	-227.5
12	5-20	32	-227.3
14	5-20	34	-231.0
16	5-20	46	-227.6
18	10-30	75	-229.3
20	10-30	85	-237.6
22	10-30	100	-235.4
24	10-30	140	-231.1
26	20-40	200	-226.2
28	20-40	240	-226.3
30	20-40	270	-226.0
32	20-40	220	-228.7
34	20-40	150	-234.1
36	30-50	200	-232.8
38	30-50	300	-232.0
40	30-50	380	-232.0
42	30-50	490	-230.7
44	30-50	600	-229.2
46	40-60	780	-228.2
48	40-60	860	-230.3
50	40-60	900	-231.1
52	40-60	900	-231.8
54	50-70	850	-232.9
56	50-70	820	-233.2
58	50-70	800	-233.9
60	50-70	830	-233.6
62	50-70	800	-233.0
64	50-70	730	-232.2
66	60-80	750	-231.2
68	60-80	920	-229.2
70	60-80	1000	-228.8
72	60-80	1050	-229.2
74	60-80	1000	-233.9
76	70-90	1000	-235.9
78	70-90	1000	-237.1
80	70-90	1200	-237.0
82	70-90	1310	-236.4
84	70-90	1500	-235.2
86	80-100	1620	-234.8
88	80-100	1720	-234.2
90	80-100	1820	-233.5
92	80-100	2000	-232.6
94	80-100	2400	-231.0
96	90-120	2800	-228.1
98	90-120	3200	-226.1
100	90-120	3400	-225.5

TABLE 2.2  
Free field frequency response  
Hydrophone No.2

Frequency kHz.	Bandwidth kHz.	Amplitude mV.	dB V/ $\mu$ Pa.
10	5-20	24	-227.5
12	5-20	30	-227.8
14	5-20	34	-231.0
16	5-20	46	-227.6
18	10-30	70	-229.9
20	10-30	85	-237.6
22	10-30	90	-236.3
24	10-30	105	-233.6
26	20-40	108	-231.6
28	20-40	125	-232.0
30	20-40	155	-230.8
32	20-40	180	-230.4
34	20-40	220	-230.8
36	30-50	285	-229.8
38	30-50	360	-230.5
40	30-50	440	-230.7
42	30-50	560	-229.5
44	30-50	675	-228.2
46	40-60	760	-228.5
48	40-60	850	-230.4
50	40-60	920	-230.9
52	40-60	1200	-229.3
54	50-70	1100	-230.7
56	50-70	1150	-230.3
58	50-70	1250	-230.1
60	50-70	1400	-229.1
62	50-70	1520	-227.5
64	50-70	1510	-225.9
66	60-80	1620	-224.5
68	60-80	2000	-222.0
70	60-80	2750	-219.9
72	60-80	2600	-221.3
74	60-80	2400	-226.3
76	70-90	2200	-229.1
78	70-90	2200	-230.3
80	70-90	2200	-231.2
82	70-90	2000	-232.7
84	70-90	1700	-234.1
86	80-100	1700	-234.4
88	80-100	1700	-234.3
90	80-100	2100	-232.3
92	80-100	2400	-231.0
94	80-100	2400	-231.0
96	90-120	2600	-228.7
98	90-120	2800	-227.3
100	90-120	2800	-227.2

Next, the reference hydrophone, LC-10, was removed and the unknown receiver was placed at the same location as the LC-10. With the same procedure as previous, the amplitude of received signals of the same frequency range were recorded. The sensitivity of the unknown hydrophone was calculated with this formula,

$$M_{ox} = M_1 V_x / V_1,$$

where  $M_{ox}$  = sensitivity of the unknown hydrophone,  
 $M_1$  = sensitivity of the reference hydrophone,  
LC-10,  
 $V_x$  = voltage amplitude of the unknown  
hydrophone,  
 $V_1$  = voltage amplitude of the reference  
hydrophone (LC-10).

The sensitivity,  $M_{ox}$ , can be expressed in dB re 1 V/ $\mu$ Pa.  
as:

$$M_{ox1} = M_{11} + 20 \log(V_x) - 20 \log(V_1),$$

where the units of  $M_{ox1}$  and  $M_{11}$  are dB re 1V/ $\mu$ Pa.

All the measured data of hydrophones No.1 & No.2 are tabulated in table 2.1 and 2.2, and plotted in Figures 4-5 respectively.

#### **4. Directivity Pattern of Hydrophone**

##### **a. Horizontal Pattern**

The horizontal directivity pattern of the hydrophones was obtained by a procedure similar to that used to determine the sensitivity. The hydrophone was placed vertically in water at a depth of 1.00 m and 1.5 m from the source. The pulse amplitude was recorded as a function of bearing by rotating the hydrophone. Ten degree steps at four frequencies were taken. These data are tabulated in Table 2.3 and plotted in Figures 6-13.

##### **b. Vertical Pattern**

A vertical pattern of hydrophone was also determined by the same procedure as the horizontal pattern, but the hydrophone had to be placed horizontally in water with the same depth and separation as previous. To keep the range between hydrophone and sound source constant during rotating, a small flexible wire was attached along the hydrophone cable and bent as shown in Figure 35. With the end of the hydrophone pointed at the sound source, the pointer was set to zero degree. The data were taken from oscilloscope as function of

angle of rotation with 10 degree steps. These data are tabulated and plotted in Table 2.4 and Figures 14-21 respectively.

#### **B. TANK TEST PREPARATION**

A fiberglass-lined wooden tank was used for the following experiments: speed of sound in water-saturated sand, speed of sound in water, reflection coefficient in water of the water-sand mixture, sound pressure as function of receiver depth over flat bottom, and normal-mode cutoff frequencies in the water column. The tank dimensions were 304 cm (length), 117 cm (width) and 95 cm (depth). Fine sand (#30) filled about half of tank. Fresh water (tap) was added to the desired depth. Before the experiment, air bubbles in the sand had to be removed. To eliminate air bubbles, high-pressure water was used. As shown in Figure 22, water in the tank was circulated through a water pump. The suction end of the pump was attached to a sand filter in the water layer. When the outlet of the water pump was put into the sand, air in the sand would be freed to rise to the surface of the water. The water outlet was moved to all parts of the tank. To avoid air entraining into the sand and water, the water outlet had to be kept under water at all times. A fine particulate residue on the surface of sand was then removed by syphon. A portion of the water had

TABLE 2.3

Horizontal Data  
Hydrophone No.1

Azimuth degrees	Frequency 100 kHz. Volts	Frequency 80 kHz. Volts	Frequency 50 kHz. Volts	Frequency 30 kHz. Volts
0	3.00	1.00	0.80	0.240
10	2.80	1.00	0.80	0.245
20	2.65	0.95	0.80	0.250
30	2.60	0.90	0.80	0.250
40	2.40	0.85	0.80	0.250
50	2.38	0.82	0.80	0.250
60	2.30	0.80	0.80	0.240
70	2.30	0.80	0.80	0.240
80	2.30	0.80	0.80	0.235
90	2.30	0.80	0.80	0.230
100	2.38	0.85	0.80	0.225
110	2.40	0.85	0.82	0.225
120	2.40	0.85	0.85	0.220
130	2.40	0.90	0.85	0.220
140	2.60	0.90	0.85	0.220
150	2.65	1.00	0.82	0.220
160	2.75	1.05	0.82	0.220
170	2.80	1.10	0.80	0.210
180	2.80	1.20	0.80	0.210
190	2.80	1.22	0.80	0.210
200	2.80	1.30	0.80	0.200
210	2.80	1.30	0.80	0.200
220	2.80	1.32	0.80	0.190
230	2.80	1.35	0.80	0.180
240	2.85	1.35	0.80	0.180
250	2.95	1.32	0.80	0.170
260	3.00	1.30	0.80	0.170
270	3.10	1.30	0.80	0.175
280	3.25	1.30	0.80	0.180
290	3.40	1.30	0.80	0.180
300	3.50	1.30	0.80	0.200
310	3.50	1.25	0.80	0.200
320	3.50	1.20	0.80	0.210
330	3.40	1.15	0.80	0.220
340	3.20	1.10	0.80	0.240
350	3.00	1.05	0.80	0.240

TABLE 2.4

Horizontal Data  
Hydrophone No.2

Azimuth degrees	Frequency 100 kHz. Volts	Frequency 80 kHz. Volts	Frequency 40 kHz. volts	Frequency 30 kHz. volts
0	2.80	1.50	0.480	0.170
10	2.80	1.50	0.480	0.170
20	2.85	1.60	0.480	0.170
30	2.90	1.60	0.480	0.165
40	2.95	1.70	0.480	0.162
50	2.95	1.75	0.480	0.162
60	2.95	1.80	0.480	0.162
70	2.95	1.80	0.480	0.160
80	2.95	1.80	0.480	0.160
90	2.93	1.80	0.480	0.160
100	2.90	1.80	0.480	0.160
110	2.80	1.90	0.480	0.158
120	2.40	2.00	0.480	0.155
130	2.15	2.10	0.478	0.150
140	2.10	2.10	0.478	0.150
150	2.10	2.00	0.478	0.150
160	2.20	1.90	0.480	0.150
170	2.30	1.85	0.480	0.150
180	2.40	1.85	0.480	0.150
190	2.40	1.90	0.482	0.155
200	2.40	1.90	0.485	0.158
210	2.42	1.90	0.485	0.160
220	2.50	1.90	0.485	0.160
230	2.50	1.90	0.485	0.160
240	2.42	1.85	0.488	0.165
250	2.40	1.80	0.495	0.165
260	2.40	1.75	0.495	0.165
270	2.40	1.70	0.490	0.170
280	2.60	1.65	0.490	0.170
290	2.80	1.55	0.488	0.175
300	2.82	1.45	0.485	0.175
310	2.82	1.40	0.485	0.175
320	2.82	1.45	0.482	0.175
330	2.80	1.50	0.482	0.175
340	2.80	1.50	0.480	0.175
350	2.80	1.50	0.480	0.175

to be changed occasionally and bleach was periodically added to the water to inhibit biological growth.

To form the sand surface flat and level, the water level in the tank was set at about 2 cm above the sand and an aluminum blade (shown in Figure 35.b) was used to scrape the surface of sand. The aluminum blade was drilled to allow the water escape while scraping. To ensure that the sand surface was flat and level, water depth all over the tank was measured after each scraping.

### III. RESULTS

Fresh water (tap) and fine sand (#30) were used in this experiment. The properties of sand and water such as density, sound speed, and reflection coefficient had to be determined before doing the shallow water experiment.

#### A. DENSITY

##### 1. Water-Saturated Sand

The density of water-saturated sand was measured by filling a 250 cc graduated cylinder with the mixture. The graduated cylinder with the mixture was then weighed as was the empty cylinder. The mass of mixture can be determined by subtracting the mass of the cylinder. While measuring the mixture, the level of water was just above the surface of the mixture. Sand from five different parts of the tank were selected. The result of these measurements are tabulated in Table 3.1. The average density of water-sand mixture was 2054 kg/m<sup>3</sup> with a standard deviation of 7.0 kg/m<sup>3</sup>.

##### 2. Water

According to Longe's "Handbook of Chemistry" [Ref. 5] the density of distilled water range from 0.99913 gm/cc to

TABLE 3.1

Water-Saturated Sand

Sample	Volume cc.	Mass gm.	Density kg/m <sup>3</sup>
1	275	567.0	2062
2	250	513.0	2052
3	300	618.0	2060
4	200	408.4	2042
5	275	564.5	2050

Average density,  $\rho_2 = 2053.8 \text{ kg/m}^3$

Standard deviation,  $\sigma_2, = \pm 7.0 \text{ kg/m}^3$

0.99707 gm/cc at the temperature of 15°C. The mean density of water at room temperature, to 3 significant figures is therefore 1.00 gm/cc.

#### B. SOUND SPEED

Speeds of sound in water and water-saturated sand were measured when the surface of sand in the tank was flat and horizontal.

## 1. Water-Saturated Sand

### a. Theoretical Sound Speed in Water-Saturated Sand

The literature contains many theoretical and experimental values for the speed of sound in sand under salt water, but few under fresh water. Bradshaw, 1980 [Ref. 6] derived a theoretical value for the speed of sound in sand under fresh water from Urick [Ref. 7]. The density of a simple additive mixture of the two components, such as water-saturated sand can be express as,

$$\rho_{\text{mix}} = \beta \rho_1 + (1 - \beta) \rho_2,$$

where  $\rho_{\text{mix}}$  = density of the mixture ( water-saturated sand),

$\rho_1$  = density of water,

$\rho_2$  = density of sand grain,

$\beta$  = porosity of the sediment, equal to the volume concentration of water in the mixture,  $\beta = 0.42$  [Ref. 6].

Urlick [Ref 7] shows that the sound velocity in the mixture can be given by,

$$c_{\text{mix}} = (\rho_{\text{mix}} k_{\text{mix}})^{-1/2} = [(\rho_1 \beta + \rho_2(1 - \beta))(k_1 \beta + k_2(1 - \beta))]^{-1/2}$$

where  $k_1$  = compressibility of water,

$k_2$  = compressibility of sand.

The values of  $k_1$  and  $k_2$  can be determined by,

$$c_1 = (1/\rho_1 k_1)^{1/2},$$

$k_1$  can be solved when  $c_1$  and  $\rho_1$  are known,

$$c_2 = (1/\rho_2 k_2)^{1/2},$$

$k_2$  can be solved when  $c_2$  and  $\rho_2$  are known.

From Anderson and Liberman [Ref. 8], the speed of sound  $c_2$  in quartz is 7000 m/s; from Hamilton [Ref. 9] the density of quartz,  $\rho_2$ , is 2.69 gm/cc. It is reasonable to assume that the sand in the tank test is quartz sand. Solving for  $k_2$  yields,

$$k_2 = 7.59 \times 10^{-15} \text{ m.sec}^2 \text{ g}^{-1}.$$

With the speed of sound in the water layer as 1505 m/s,

$$k_1 = 4.41 \times 10^{-11} \text{ m.sec}^2 \text{ g}^{-1}.$$

Substituting these values and solving for speed of sound in mixture,  $c_{mix}$ , the speed of sound in water-saturated sand is 1656 m/s. Urick also said that measured speeds of sound in the mixture are somewhat higher than those given by this formula for low-porosity partly-indurated sediments, where there is grain-to-grain contact of the sediment particles.

**b. Measurement of the Sound Speed in Water-Saturated Sand**

Figure 23 shows the equipment set up for the measurement of the speed of sound in water-saturated sand. Three hydrophones (LC-10's) were used in this experiment; one as a sound source, the other two as receivers. A ruler was laid down over the surface of sand under 5 cm of water. All source and receivers were submersed into the sand about 15 cm from the surface of sand.

A function generator (Wavetex model 116) generated a 150 kHz CW signal. This was sent to a tone burst generator (General Radio Company Type 1396-A) with gate setting of 16 cycles opened and 128 cycles closed. The output of the tone burst generator was sent through a power amplifier with unit gain and fed to an LC-10 source. Received signals were obtained by the two LC-10 receivers, sent through HP465A pre-

amplifier, bandpass filters (SKL model 302) and displayed on an oscilloscope (COS-5060). The distance and time differences between the two receivers LC-10 were measured and tabulated in Table 3.2. The first data were taken after the LC-10 receivers were put into sand about 24 hours and 48 hours respectively. The first and the second values were almost the same. Then the receiver was moved to different place. All the rest of data were taken after 24 hours. The reason to do this was to ensure equilibrium packing of sand grains around the receiver. The average of sound speed in the water-saturated sand was 1680 m/s with the standard deviation of 24.4 m/s. Compared with the theoretical value of 1656 m/s, this is about 2% higher than predicted.

## 2. Water

Two separate sets of speed of sound data in water were made. The first involved the use of a velocimeter and the second was the same technique as the measurement of speed of sound in water-saturated sand.

Figure 24 shows the diagram and equipment set up for measurement of the speed of sound with a velocimeter which uses the pulse superposition technique. From the Figure 24, the velocimeter was filled with a sample of water. The function generator (HP3314A) generated a high frequency signal

TABLE 3.2

Speed of sound in mixture

Source and receiver depth = 15 cm under sand surface

Water layer = 5 cm

Frequency = 150 kHz

Tone burst gate open = 16 cycles

close = 128 cycles

Distance cm.	Time $\mu$ sec	Sound speed m/s
20.0	120	1667
29.8	178	1674
24.5	145	1714
21.8	130	1676
14.8	90	1644
35.5	210	1705
26.7	160	1669
19.0	115	1652
12.0	70	1714

Mean sound speed,  $c_2$  = 1680 m/s.Standard deviation,  $\sigma_2$  =  $\pm$  24 m/s.

on the order of 2.5 MHz and was triggered by a signal which generated by wave analyzer (HP302A). The output signal from function generator was sent to a transmitter of velocimeter and an oscilloscope trigger input. Received signals from the velocimeter receiver were sent through a voltage amplifier (HP465A) and displayed on the oscilloscope. The data were obtained by increasing the frequency of the wave analyzer while watching at the oscilloscope and noticing the pulse trains moving. The pulses become superimposed for the first time at about 5 kHz. Since the distance between the transmitter and receiver of velocimeter was 15.24 cm the values of frequency obtained (from wave analyzer) when the pulse trains were superimposed were the values of the speed of sound in the sample in feet per second. This was converted into meter per second. Six determinations are tabulated in Table 3.3. The average sound speed is 1494 m/s with a standard deviation of  $\pm 2$  m/s.

Figure 23 shows the equipment and circuit used to measure the speed of sound in water by the time-of-flight technique. Two LC-10 hydrophones were used as the receivers and an ITC-5095 Sn352 transducer was used as the source. A high frequency tone burst of about 200 KHz was used. The

speed of sound was calculated by direct measurement of the time-of-flight on the oscilloscope and the distance between

TABLE 3.3

Speed of sound in water  
using velocimeter

Frequency Hz.	Sound speed m/s
4899	1493.2
4897	1492.7
4897	1492.7
4906	1495.6
4908	1495.9
4896	1492.5

Average sound speed = 1493.7 m/s.

Standard deviation =  $\pm 1.4$  m/s.

the two receivers. The experimentally determined values are tabulated in Table 3.4. The average sound speed is 1505 m/s with the standard deviation of  $\pm 26$  m/s.

**C. REFLECTION COEFFICIENT OF WATER-SATURATED SAND**

Normal-incident pressure reflection coefficients were measured and compared with the value calculated from the measured speeds of sound and densities in water-saturated sand and water.

TABLE 3.4

Speed of sound in water  
using time of flight

Water layer = 20 cm

Frequency = 170 kHz.

Tone burst gate open = 16 cycles

close = 128 cycles

Source-Receiver distance, cm.	Time $\mu$ sec	Sound speed m/s
10.00	65	1538
15.35	100	1535
20.75	138	1504
25.50	168	1518
30.65	202	1517
35.55	240	1481
40.70	275	1475
45.55	300	1518
51.10	350	1460

Average sound speed,  $c_1$  = 1505 m/s.

Standard deviation,  $\sigma_1$  =  $\pm$  26 m/s.

Figure 25 shows the diagram and equipment set up for this measurement. The sound source (ITC-5095 Sn352) and receiver (LC-10) were mounted on the same platform so that the radiator and receiver are at fixed separation and can be rotated 180 degrees. A frequency of 150 KHz and pulse duration of 16 cycles was used. First, the platform was placed under the water with the radiating surface pointing up to the surface of water. The distance between radiating face and the water surface was 30 cm. The shape and amplitude of waveform were investigated and sketched from the oscilloscope. Second, the platform was rotated 180 degrees downward and the distance between the radiating surface and bottom surface (sand) was adjusted to 30 cm. Without any change of equipment, the amplitude of the output waveform of the LC-10 was adjusted to be the same as previously (radiating surface upward) and sketched. Both waveforms are shown in Figure 26.

Comparison of the waveforms indicates the same shape when pointing upward and downward. The reflection coefficient was obtained by the ratio of the voltage amplitude from the oscilloscope while the radiating face was pointing downward and upward with the same distance. The data were taken at three different locations in the tank test as shown in table

3.5. The experimentally determined value of pressure reflection coefficient is  $0.34 \pm 0.01$ .

From KFCS [Ref. 10] the pressure reflection coefficient for normal incident is given by

$$R = (r_s - r_w) / (r_s + r_w)$$

$$r = \rho c,$$

where  $r_w$  = characteristic impedance of water,

$r_s$  = characteristic impedance of water-saturated sand,

$\rho$  = medium density,

$c$  = speed of sound in medium.

Using the previous values of  $\rho_w$ ,  $c_w$ ,  $\rho$ , and  $c$ , yield

$$R = 0.39$$

which is 12.8 % higher than measured value.

TABLE 3.5  
Experimental reflection Coefficient

Sample	Water Surface Volts	Sand Surface Volts	Ratio
1	4.0	1.4	0.35
2	5.8	2.0	0.34
3	9.5	3.3	0.35

#### D. NORMAL-MODE CUTOFF FREQUENCY

The normal-mode cutoff frequencies in the water column were also measured as a check of the measured sound speeds in the water and the water-sand mixture. From KFCS [Ref. 10], the family of cutoff frequencies are given by

$$f_n = (n - 1/2) (1/2H) c_w [1 - (c_w/c_s)^2]^{-1/2}$$

where  $f_n$  = normal-mode cutoff frequency,

$c_w$ ,  $c_s$  = speed of sound in water and water-sand mixture respectively,

$H$  = water layer depth, m,

$n$  = 1, 2, 3 ..... (mode number).

Figure 36 shows the equipment set up for measurement of cutoff frequencies in the water column. The cutoff frequencies were obtained by notice the pulse amplitude just occurred at the hydrophone on the oscilloscope and the frequencies on the oscillator were recorded for different layer depth. These frequencies are the normal-mode cutoff frequency. The first normal-mode cutoff frequency was measured for 5 different layer depths; the experimental and theoretical data are shown in Table 3.6 and plotted in Figure 27.

TABLE 3.6

First normal mode cutoff frequencies

Speed of sound ratio = 0.83

Depth (cm)	Cutoff frequencies (kHz)	
	Experiment	Theory
5.5	12.5	15.4
6.5	11.0	13.0
7.5	10.5	11.3
9.0	8.5	9.4
10.0	7.5	8.5

**E. SOUND PRESSURE AS FUNCTION OF RECEIVER DEPTH OVER A FLAT BOTTOM**

**1. Theory**

Shallow water acts like a wave guide with a pressure release boundary at the surface of water and partial reflection from the bottom. From KFCS [Ref. 10], the acoustic pressure in water layer for  $K_n r \gg 1$  can be expressed as,

$$p(r,z,t) = -j \sum_{n=0}^{\infty} \sqrt{\frac{2\pi}{K_n r}} A_n^2 \sin(k_{zn} z_0) \sin(k_{zn} z) e^{j(\omega t - K_n r + \pi/4)}$$

where  $z_0$  = source depth,

$z$  = receiver depth,

$r$  = horizontal distance between source and receiver, and

$$A_n^2 = \frac{2k_{zn}}{k_{zn}H - \cos(k_{zn}H)\sin(k_{zn}H) - (\rho_1/\rho_2)^2 \sin^2(k_{zn}H)\tan(k_{zn}H)}$$

The eigenvalue,  $k_{zn}$ , can be solved from the transcendental equation,

$$\tan(y) = -by / (a^2 - y^2)^{1/2},$$

where  $y = k_{zn}H,$

$$b = \rho_2/\rho_1,$$

$$a = \omega H(1/c_1^2 - 1/c_2^2)^{1/2}.$$

The values of  $y$  that satisfy the transcendental equation allow calculation of

$$k_{zn} = y / H.$$

$K_n$  can be solved by following equation,

$$k_{zn}^2 = (\omega/c_1)^2 - K_n^2.$$

Some values of  $k_{zn}$ ,  $K_n$  and  $A_n$  are calculated and tabulated in Table 3.7. In this experiment, the first two lowest modes were measured.

For the first mode ( $n = 1$ ) the acoustic pressure in the water layer is

$$|p(r,z,t)| = |(2\pi/K_1r)^{1/2} A_1^2 \sin(k_{z1}z_0)\sin(k_{z1}z)[\sin(-K_1r+\pi/4)-j\cos(-K_1r+\pi/4)]|,$$

and for the sum of first ( $n = 1$ ) and second ( $n = 2$ ) mode is

$$|p(r,z,t)| = |(2\pi/K_1r)^{1/2} A_1^2 \sin(k_{z1}z_0)\sin(k_{z1}z)[\sin(-K_1r+\pi/4)-j\cos(-K_1r+\pi/4)] + (2\pi/K_2r)^{1/2} A_2^2 \sin(k_{z2}z_0)\sin(k_{z2}z)[\sin(-K_2r+\pi/4)-j\cos(-K_2r+\pi/4)]|.$$

TABLE 3.7

Values of  $k_{zn}$  and  $K_n$

Modes n	Frequency kHz.	$k_{z1}$	$K_1$	$k_{z2}$	$K_2$	$A_n$
1	9.5	17.14	34.56	-	-	2.43
1	15.0	21.13	58.95	-	-	3.88
1	18.0	22.25	71.78	-	-	3.96
1	20.0	22.87	80.31	-	-	3.99
2	30.0	25.12	122.10	52.49	113.71	4.17
2	35.0	25.48	143.88	53.08	136.14	4.22
2	40.0	26.13	164.94	54.11	157.99	4.27

## 2. Sound Pressure Measurement

Figure 36 shows the circuit for the measurement of the variation of pressure amplitude with range and depth. Continuous waves of desired frequencies were generated by a function generator (Wavetek Model 116A) and were applied to the source through a tone burst generator (General Radio Company Model 1396-A) and power amplifier (HP-467A). The tone burst generator was set to 8 - 16 cycles opened and 128

cycles closed. The source was placed in the water at 5.0 cm depth. The pressure field was obtained by the receiver and passed through bandpass filter (SKL Model 302) and voltage amplifier (HP 465-A). The voltage amplifier was set to 60 dB. To eliminate noise, a filter bandwidth of 5 kHz was used for each frequency. The signal from filter were displayed on oscilloscope (COS-5060) and recorded. To determine the variation of pressure as a function of receiver depth, the source was kept at a fixed depth (5.0 cm) in the water layer while the measurements were made with the receiver at fixed range beginning from the top surface of water layer down to the surface of the bottom in steps of 0.5 cm. Four frequencies of the first mode and three of the second mode were selected for measurement. The measurement data are tabulated in Tables 3.7 & 3.8 and plotted in Figures 28-34. The experimental and theoretical results agree satisfactorily in the first mode and slightly difference in the sum of first and second mode.

TABLE 3.8

Sound Pressure in Water Layer

Source - LC-10      Receiver - hydrophone No.1  
 Source - Receiver distance = 80.5 cm.  
 Source depth = 5 cm.  
 Water Layer depth = 9.5 cm.  
 pulse width = 16 cycles

---

No.	Frequency			
	9.5 kHz. mV.	15 kHz. mV.	18 kHz. mV.	20 kHz. mV.
0	0	0	0	0
1	6	3	5	4
2	8	5	8	8
3	12	7	12	12
4	16	8	15	14
5	20	10	18	16
6	24	12	19	20
7	28	14	22	23
8	30	16	24	26
9	32	17	28	29
10	34	18	28	32
11	36	20	29	34
12	38	21	30	36
13	40	22	30	38
14	41	23	30	40
15	42	24	30	40
16	42	25	29	40
17	42	26	28	39
18	42	24	26	36
19	41	23	24	34

TABLE 3.9  
Sound Pressure in Water Layer

Source -Directional                      Receiver - Hydrophone No.1  
 Source - receiver distance = 58 cm  
 Source Depth = 3 cm  
 Water-Layer depth = 9.5 cm  
 Pulse-width = 16 cycles

---

No.	Frequency		
	30 kHz mV	35 kHz mV	40 kHz. mV
0	0	0	0
1	6	4	10
2	12	6	20
3	14	8	26
4	15	12	34
5	16	14	44
6	18	18	52
7	20	22	52
8	21	20	41
9	22	18	28
10	21	15	12
11	18	10	14
12	16	5	26
13	13	6	44
14	12	12	52
15	13	19	60
16	14	25	65
17	14	28	70
18	13	30	65
19	13	28	60

#### IV. CONCLUSIONS

The average free field frequency response of hydrophones in the range of 10-100 kHz were 231.4 dB re 1v/uPa for hydrophone No.1 and 229.7 dB re 1v/uPa for hydrophone No.2. The sound speed of water-saturated sand was measured to be 1680 m/s, in agree with literature or theoretical values. The density of water-saturated sand was 2054 kg/m<sup>3</sup> with a standard deviation of  $\pm 7.0$  kg/m<sup>3</sup>. The speed of sound in water obtained by using either the velocimeter or the direct measurement of time of flight were 1494 m/s with a standard deviation of  $\pm 1.4$  m/s and 1505 m/s with standard deviation of  $\pm 26$  m/s respectively. The normal-incident pressure reflection coefficients was 0.34 which is 12.8 % lower than theoretical values.

The experimental curves for pressure amplitude in shallow water model as a function of receiver depth for 4 different frequencies of the first normal-mode agreed satisfactorily with the theory and with the experimental results of Tariq and Rungsirotekomol. For the three different frequencies the sum of the first and the second normal-mode gave experimental values slightly different from the theoretical values.

The apparatus developed for this thesis has been shown to accurately model sound propagation in shallow water with a flat sandy bottom and is now available for the study of more complicated bottom topographies.

### Construction of Hydrophone

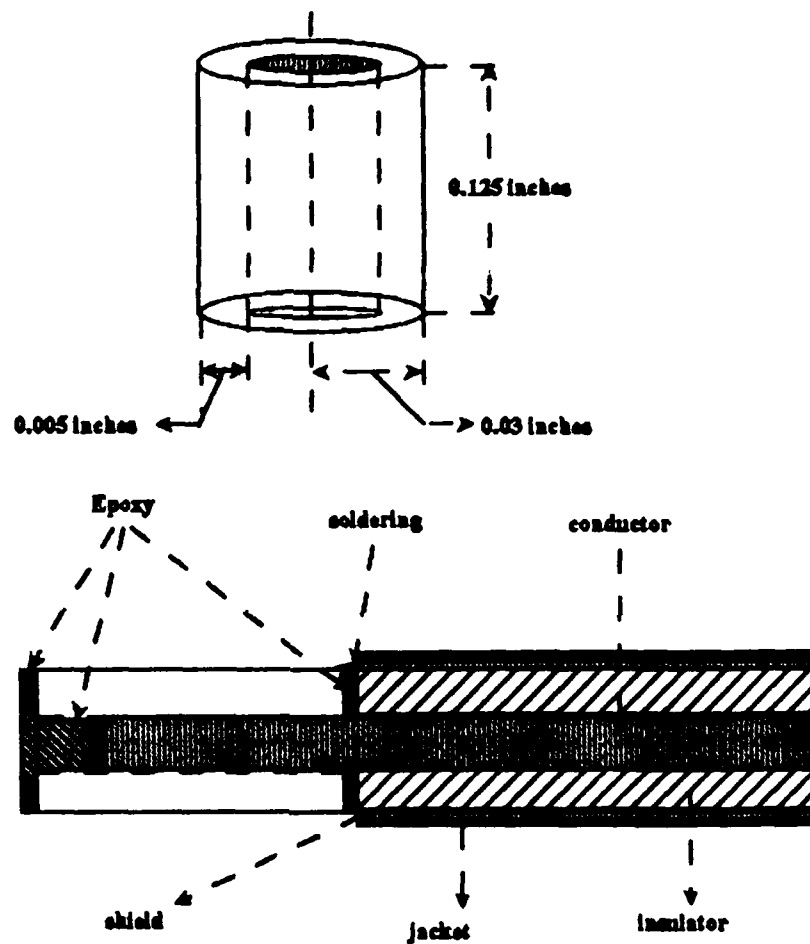

Figure 1 Construction of Hydrophone

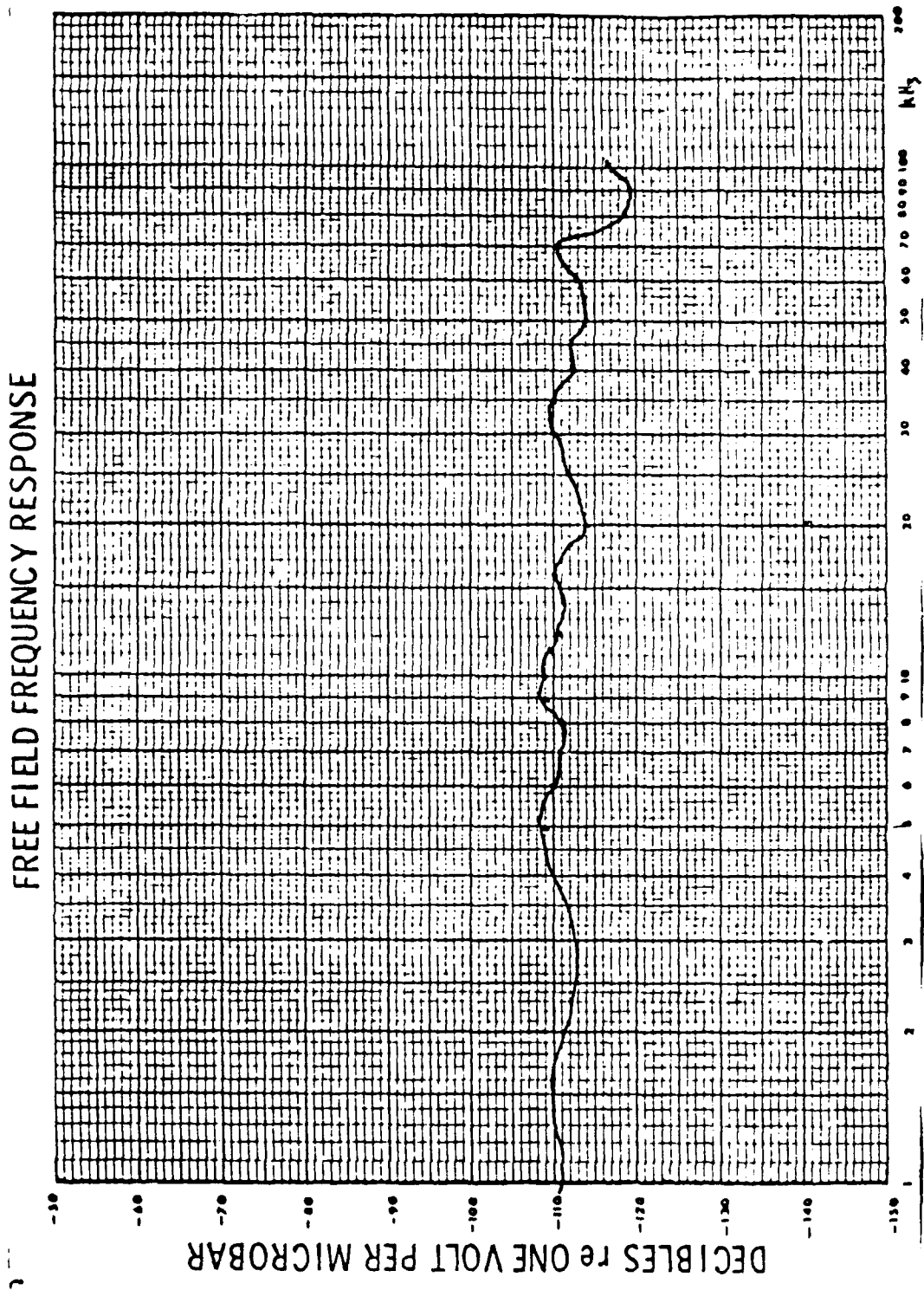
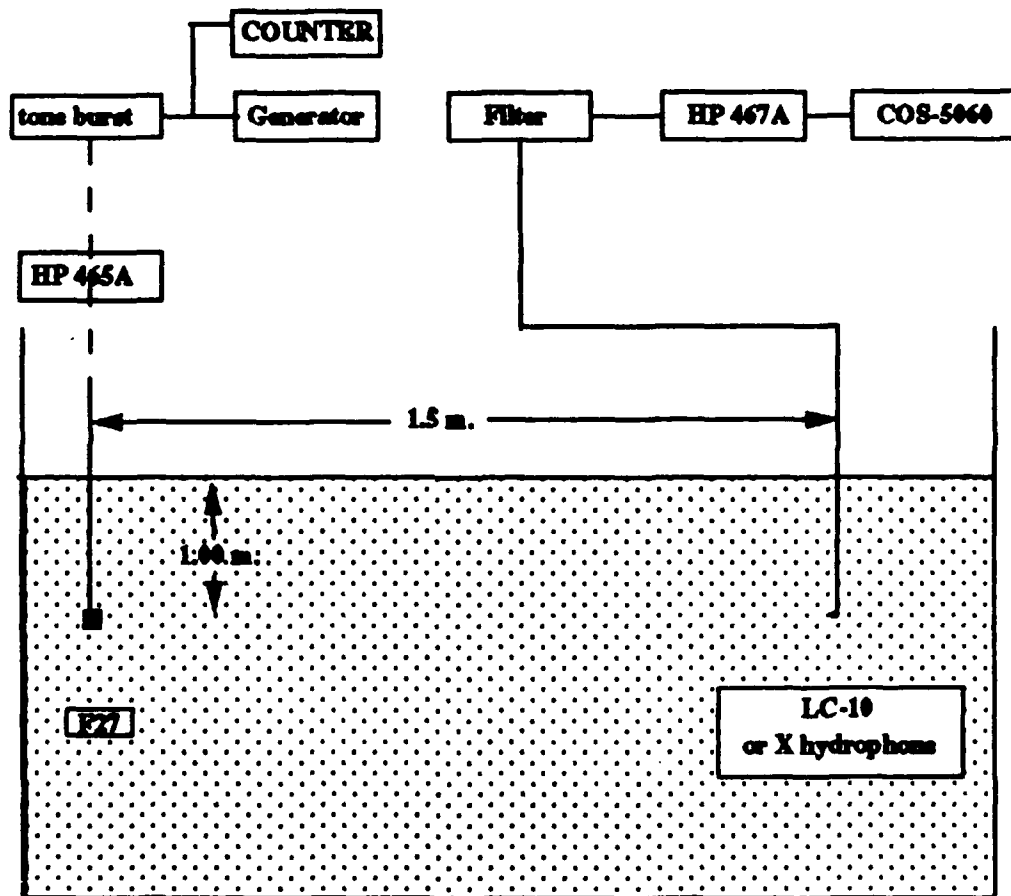
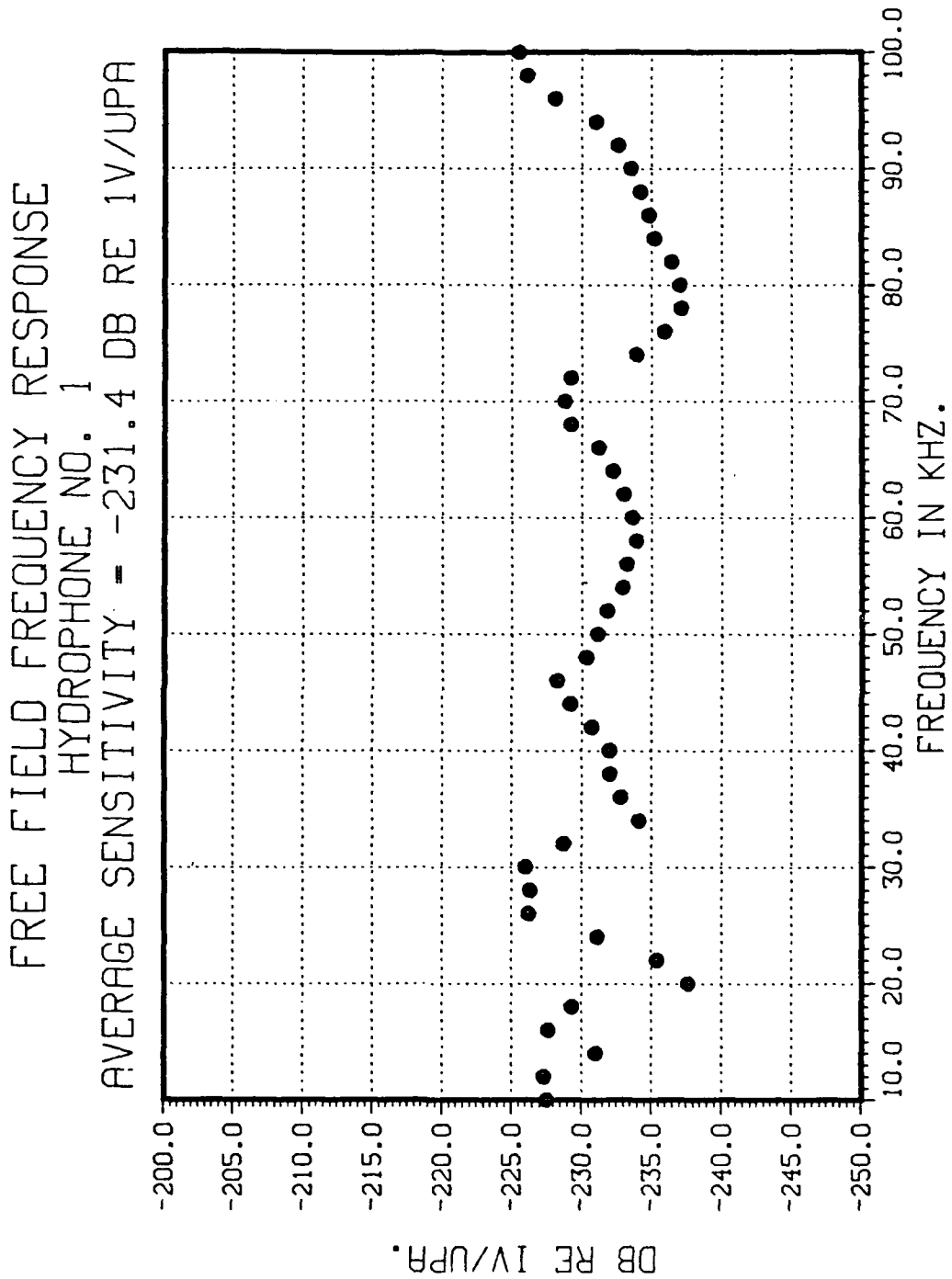

Figure 2 LC-10 Far Field Frequency Response Curve

## Calibration of Hydrophone by Direct Comparison Method



**Figure 3** Calibration of Hydrophone by Direct Comparison Method



**Figure 4** Hydrophone No.1 Far Field Frequency Response Curve.

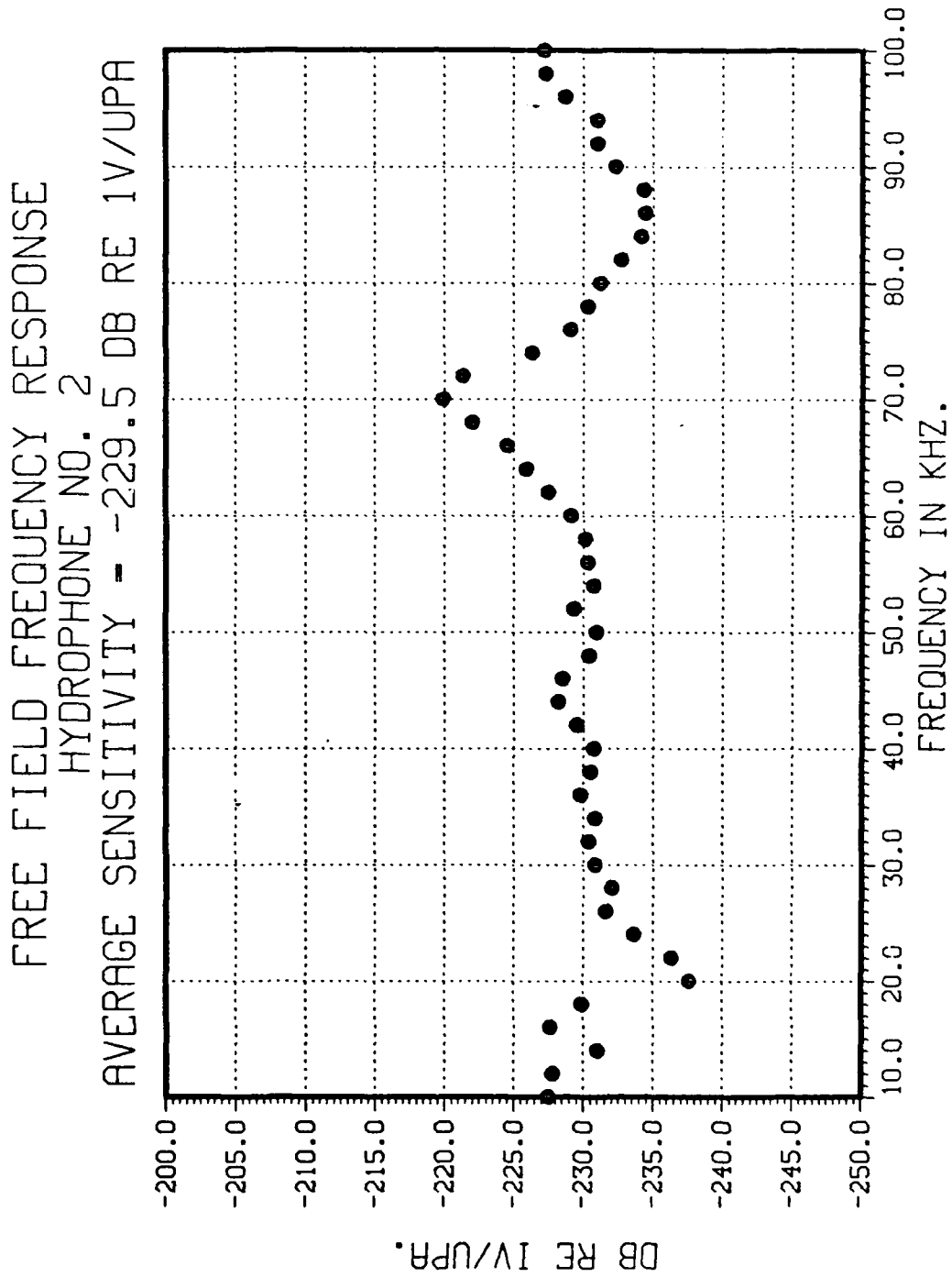

**Figure 5** Hydrophone No. 2 Far Field Frequency Response Curve.

DIRECTIVITY OF HYDROPHONE

FREQUENCY = 30 KHZ

HYDROPHONE NO. 1

HORIZONTAL

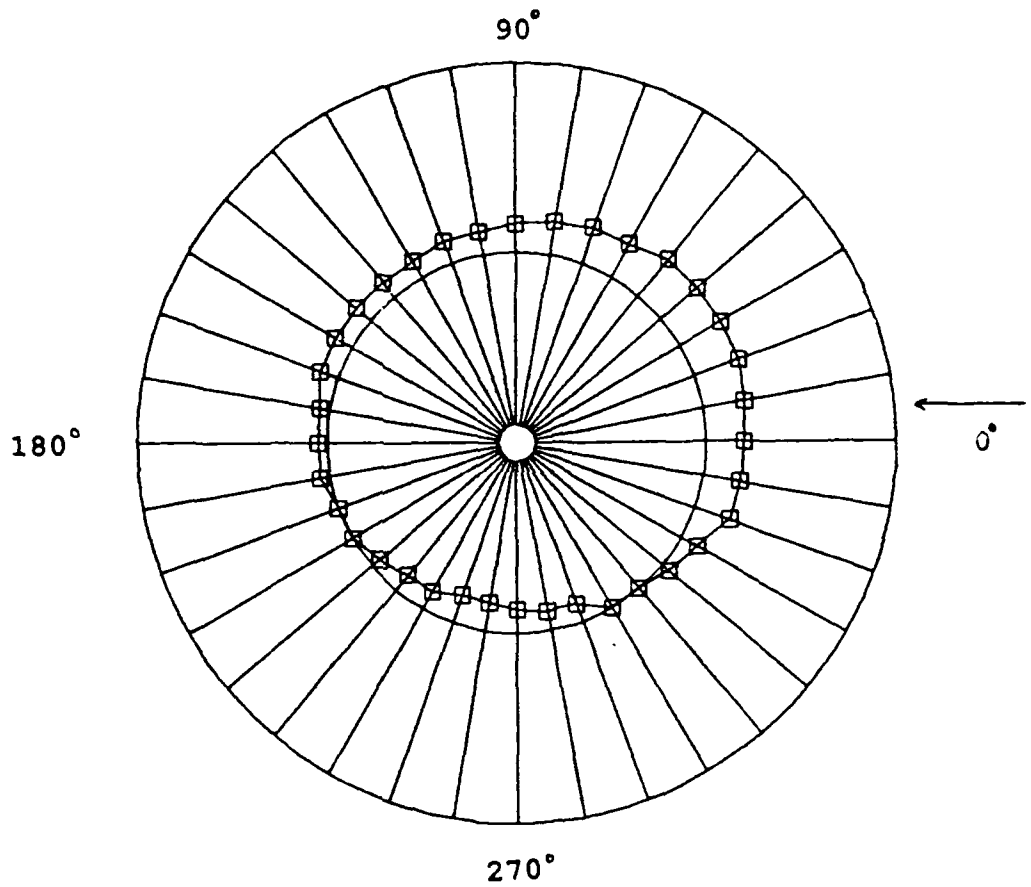

**Figure 6** Horizontal Directivity Pattern of Hydrophone No.1, 30 kHz.

# DIRECTIVITY OF HYDROPHONE

FREQUENCY = 50 KHZ

HYDROPHONE NO. 1

HORIZONTAL

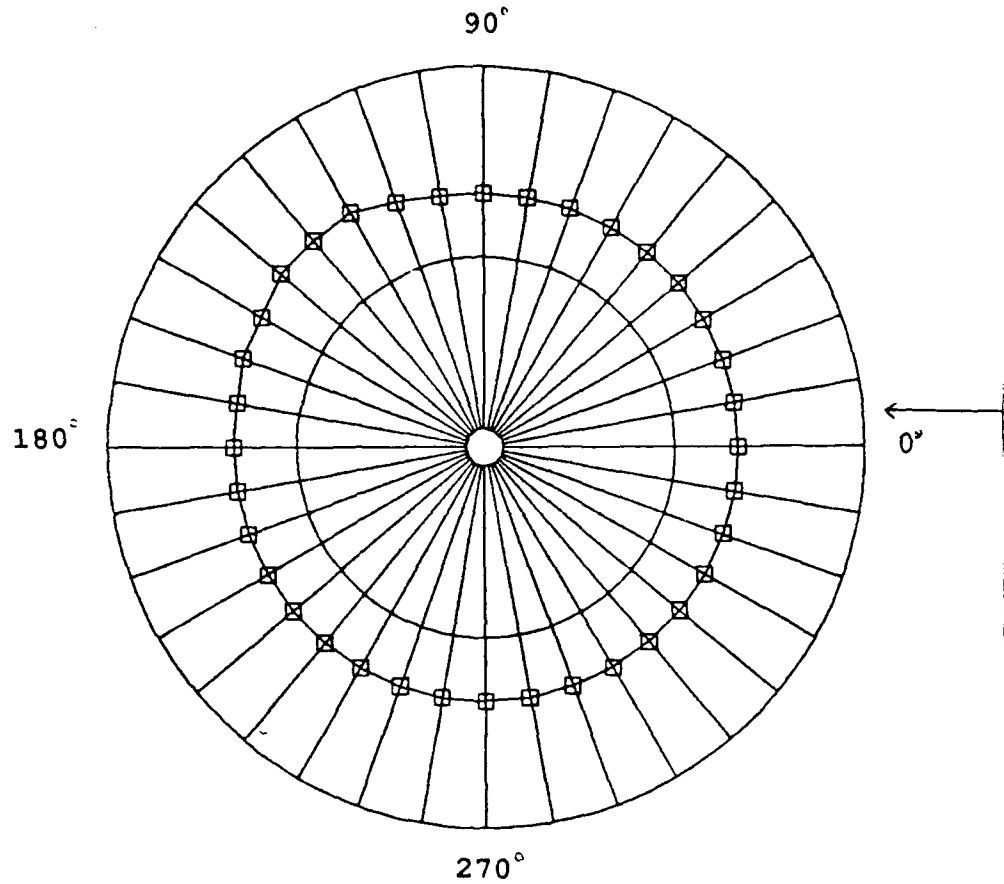

**Figure 7** Horizontal Directivity Pattern of Hydrophone No.1, 50 kHz.

# DIRECTIVITY OF HYDROPHONE

FREQUENCY = 80 KHZ

HYDROPHONE NO. 1

HORIZONTAL

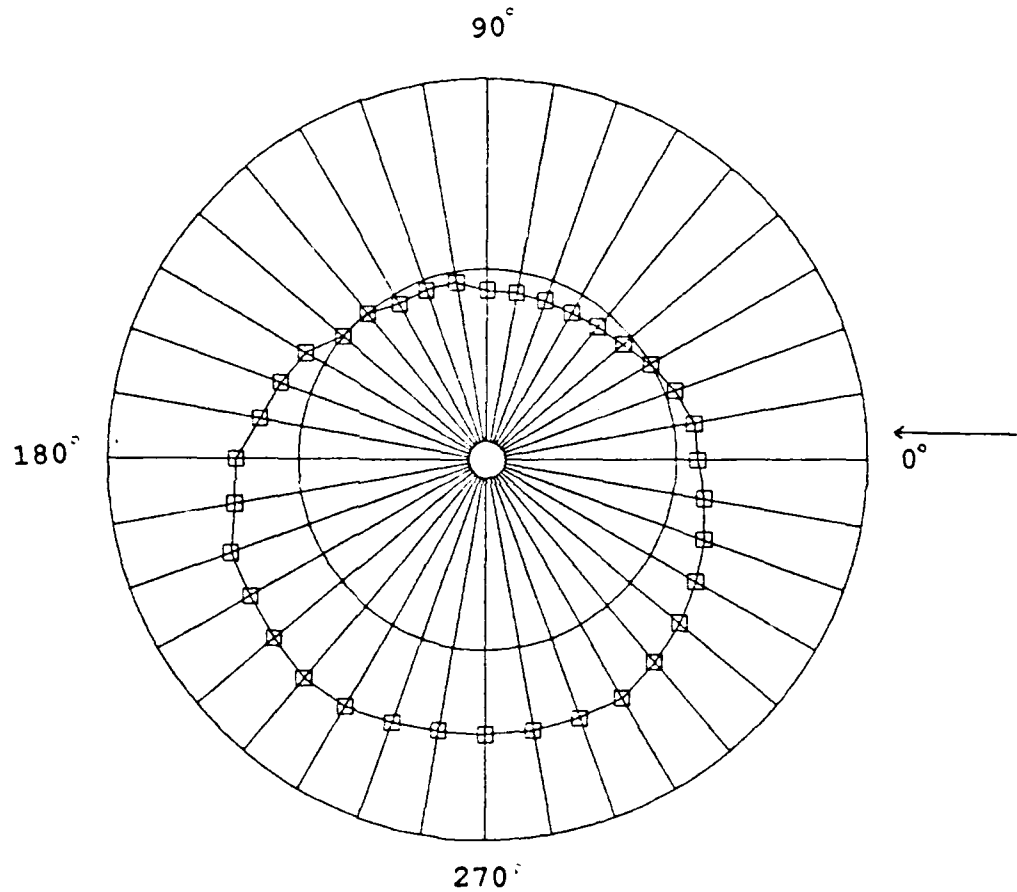

**Figure 8** Horizontal Directivity Pattern of Hydrophone No.1, 80 kHz.

# DIRECTIVITY OF HYDROPHONE

FREQUENCY = 100 KHZ

HYDROPHONE NO. 1

HORIZONTAL

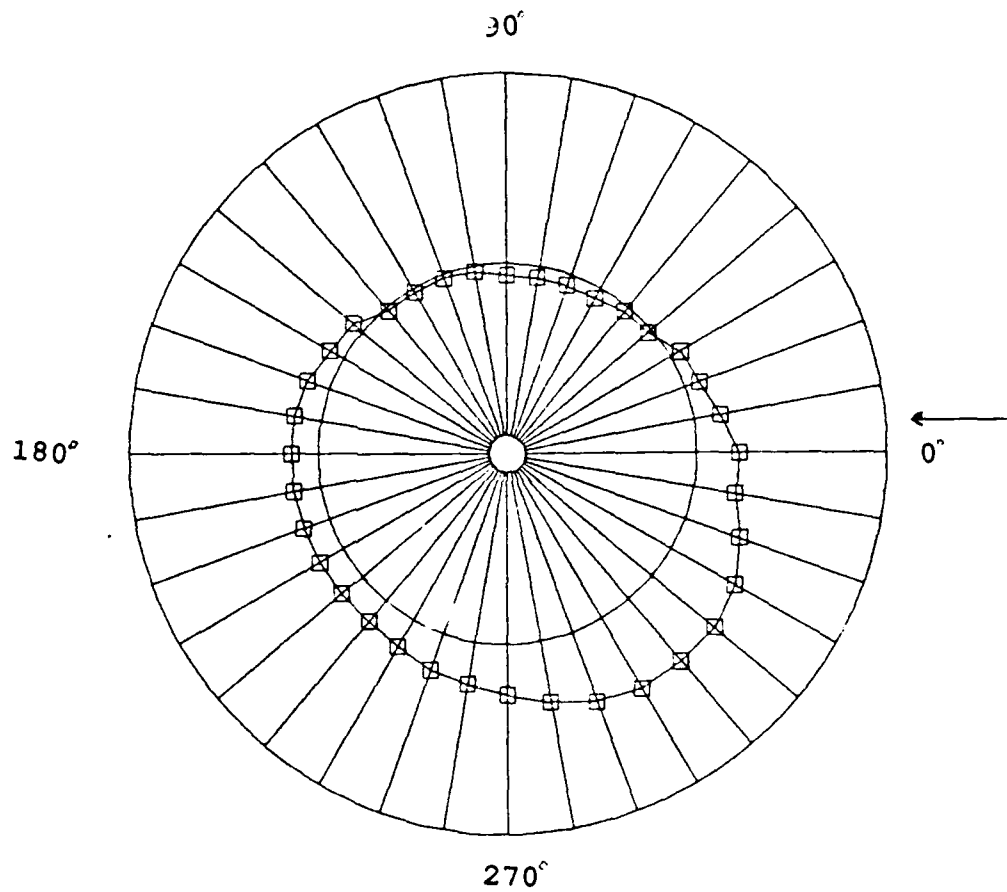

**Figure 9** Horizontal Directivity Pattern of Hydrophone No.1,  
100 kHz.

# DIRECTIVITY OF HYDROPHONE

FREQUENCY = 30 KHZ

HYDROPHONE NO. 2

HORIZONTAL

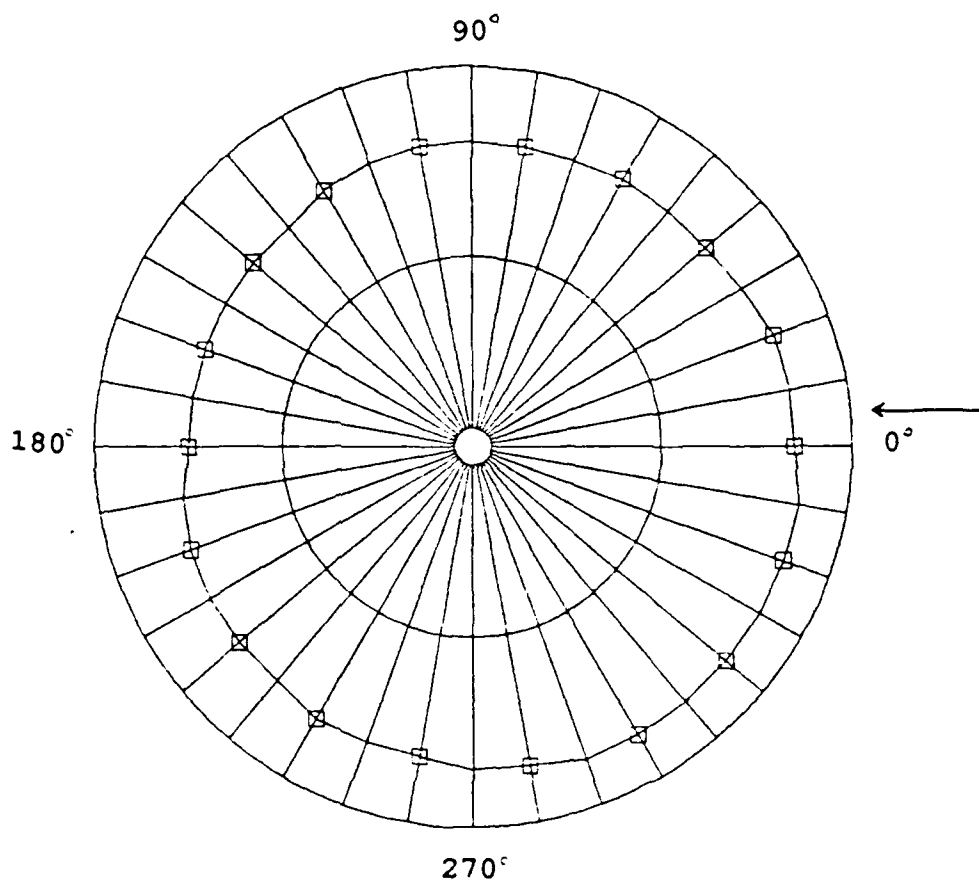

**Figure 10** Horizontal Directivity Pattern of Hydrophone No.2, 30 kHz.

# DIRECTIVITY OF HYDROPHONE

FREQUENCY = 40 KHZ

HYDROPHONE NO. 2

HORIZONTAL

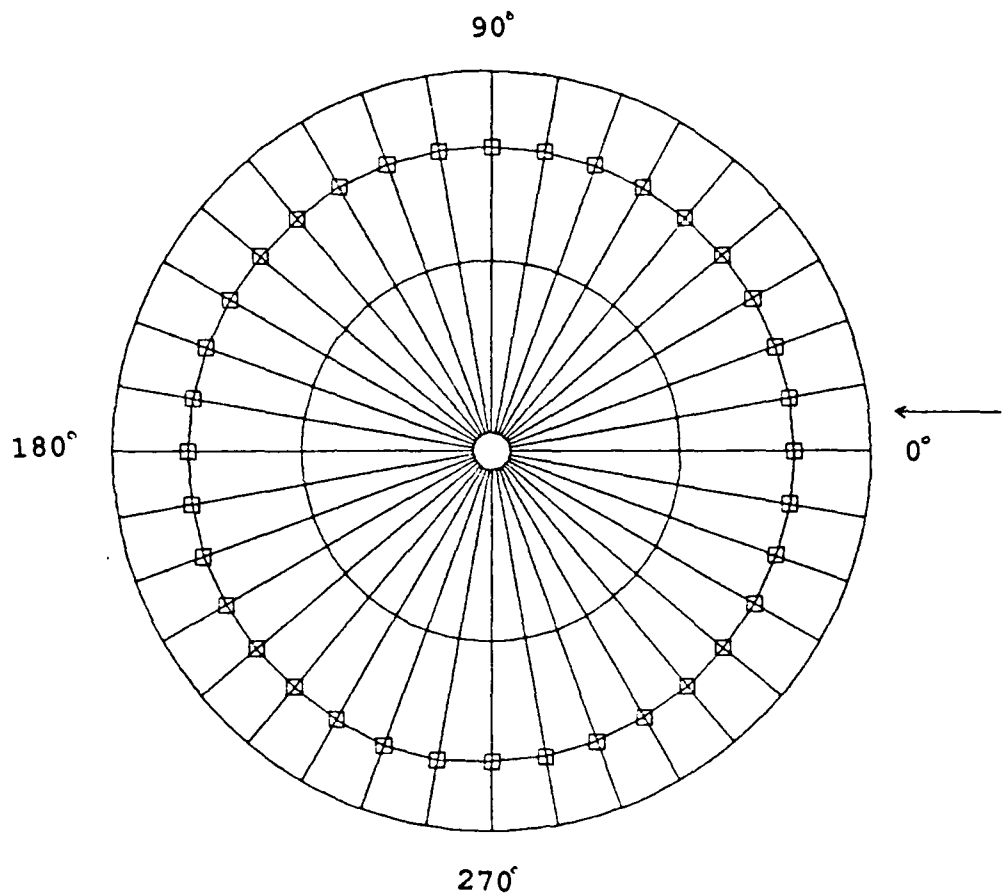

**Figure 11** Horizontal Directivity Pattern of Hydrophone No.2,  
40 kHz.

DIRECTIVITY OF HYDROPHONE

FREQUENCY = 80 KHZ

HYDROPHONE NO. 2

HORIZONTAL

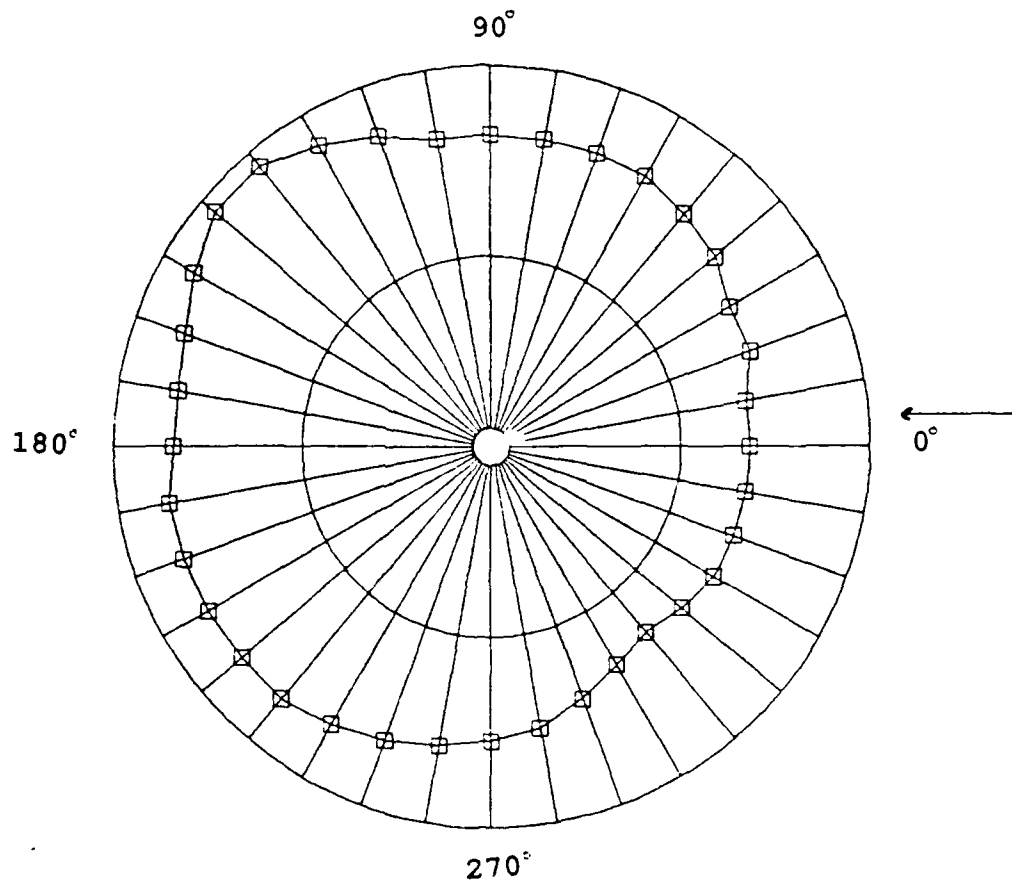

**Figure 12** Horizontal Directivity Pattern of Hydrophone No.2,  
80 kHz.

# DIRECTIVITY OF HYDROPHONE

FREQUENCY = 100 KHZ

HYDROPHONE NO. 2

HORIZONTAL

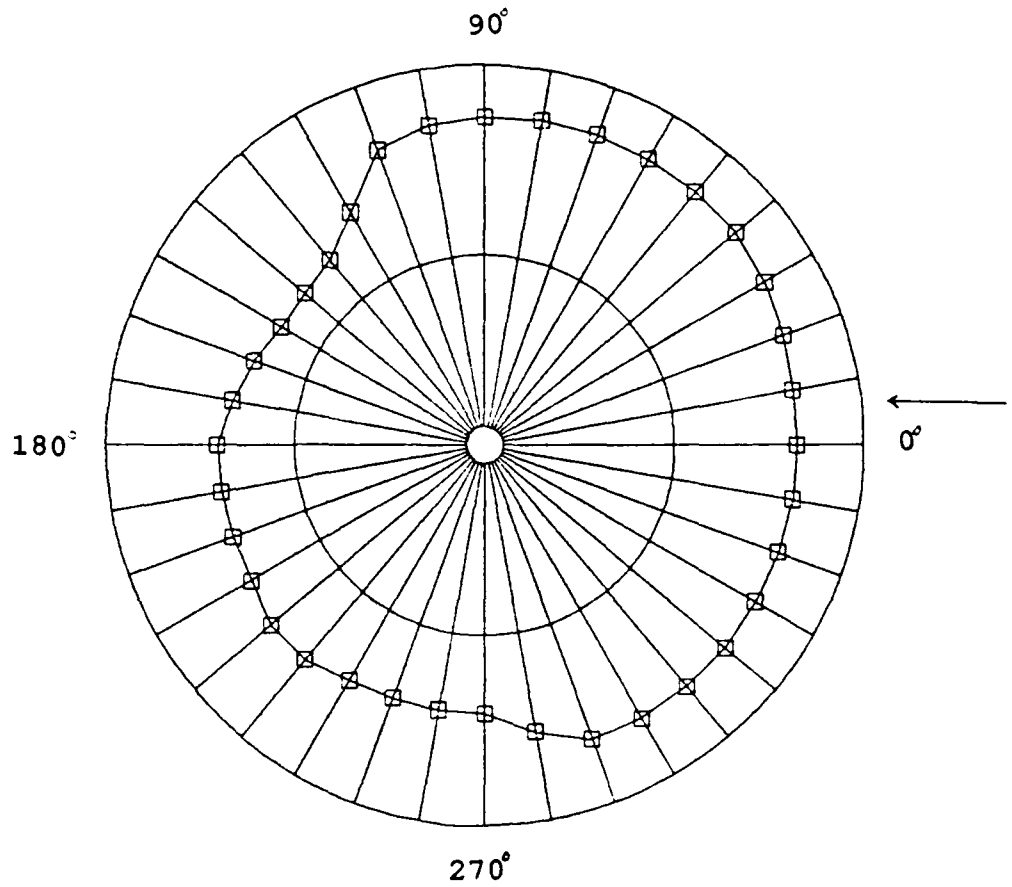

**Figure 13** Horizontal Directivity Pattern of Hydrophone No.2, 100 kHz.

DIRECTIVITY OF HYDROPHONE

FREQUENCY = 30 KHZ

HYDROPHONE NO. 1

VERTICAL

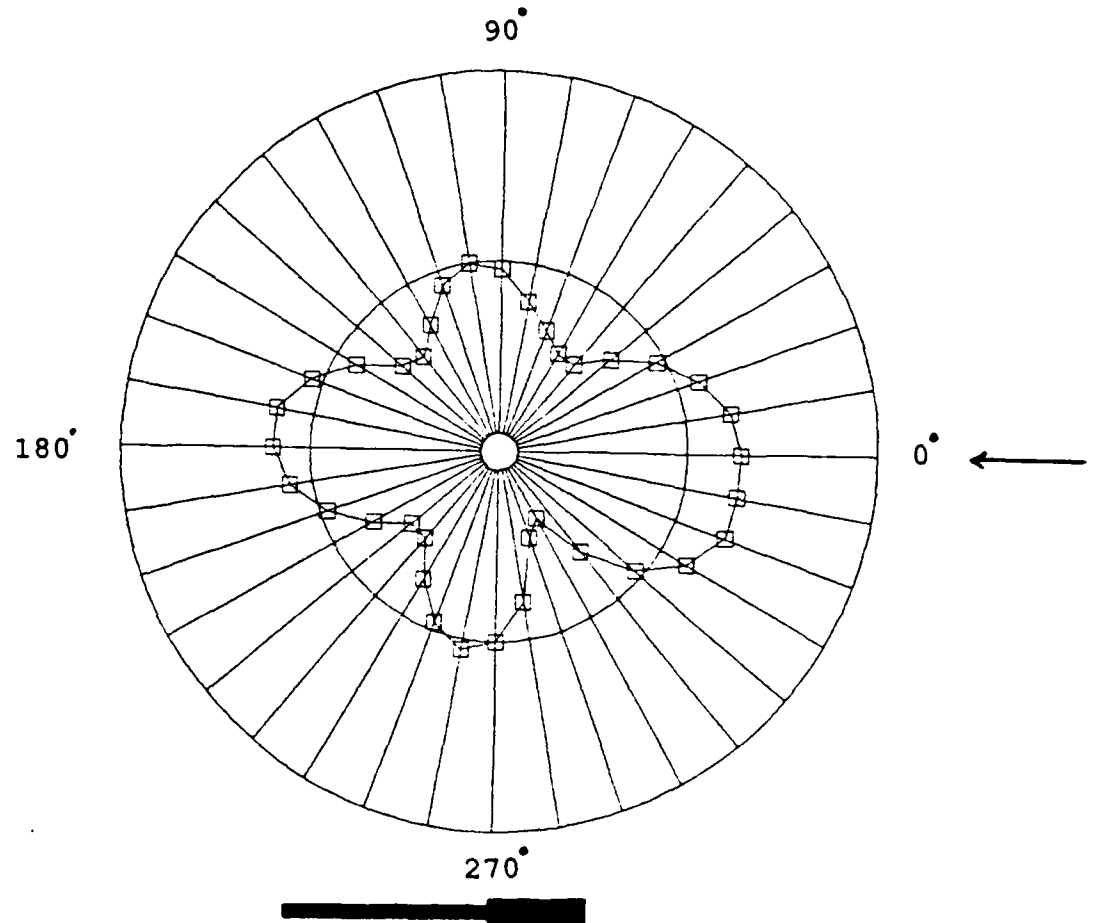

**Figure 14** Vertical Directivity Pattern of Hydrophone No.1, 30 kHz.

# DIRECTIVITY OF HYDROPHONE

FREQUENCY = 50 KHZ

HYDROPHONE NO. 1

VERTICAL

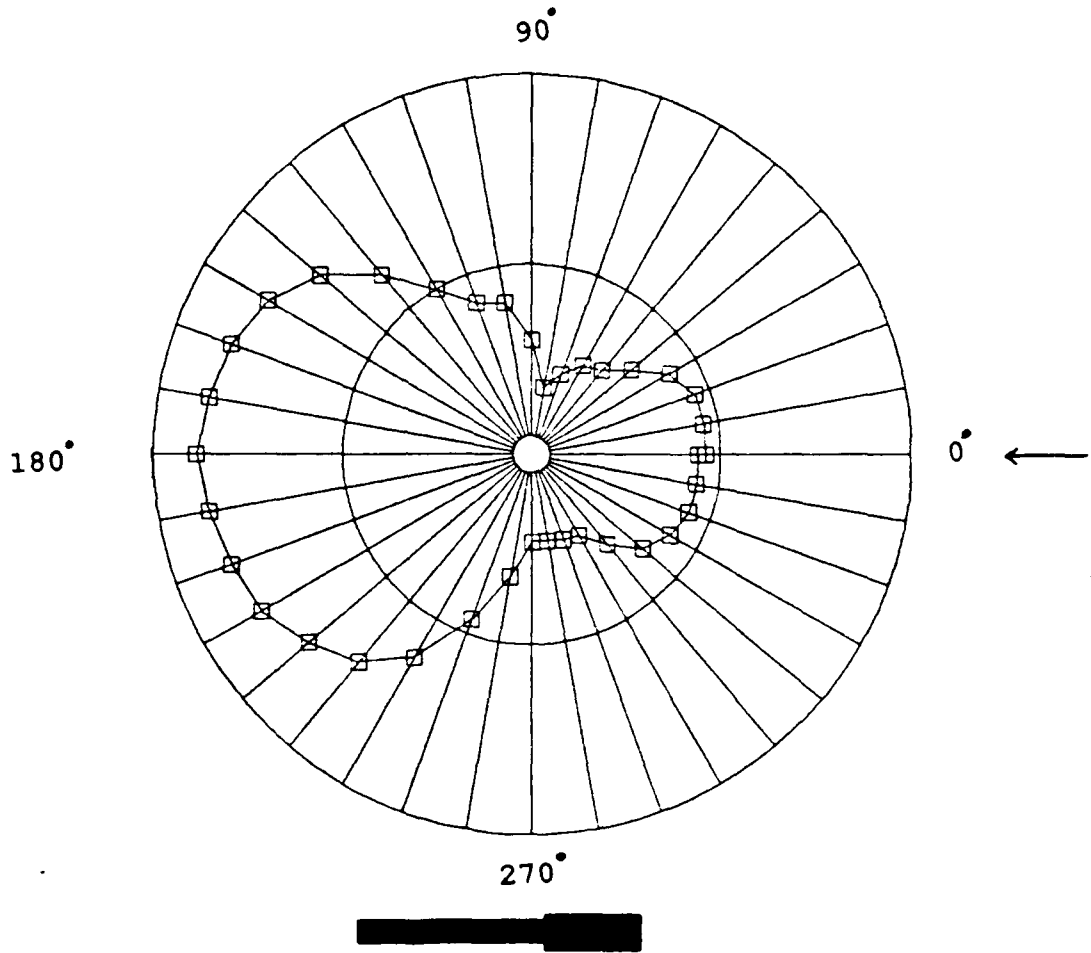

**Figure 15** Vertical Directivity Pattern of Hydrophone No.1, 50 kHz.

DIRECTIVITY OF HYDROPHONE

FREQUENCY = 80 KHZ

HYDROPHONE NO. 1

VERTICAL

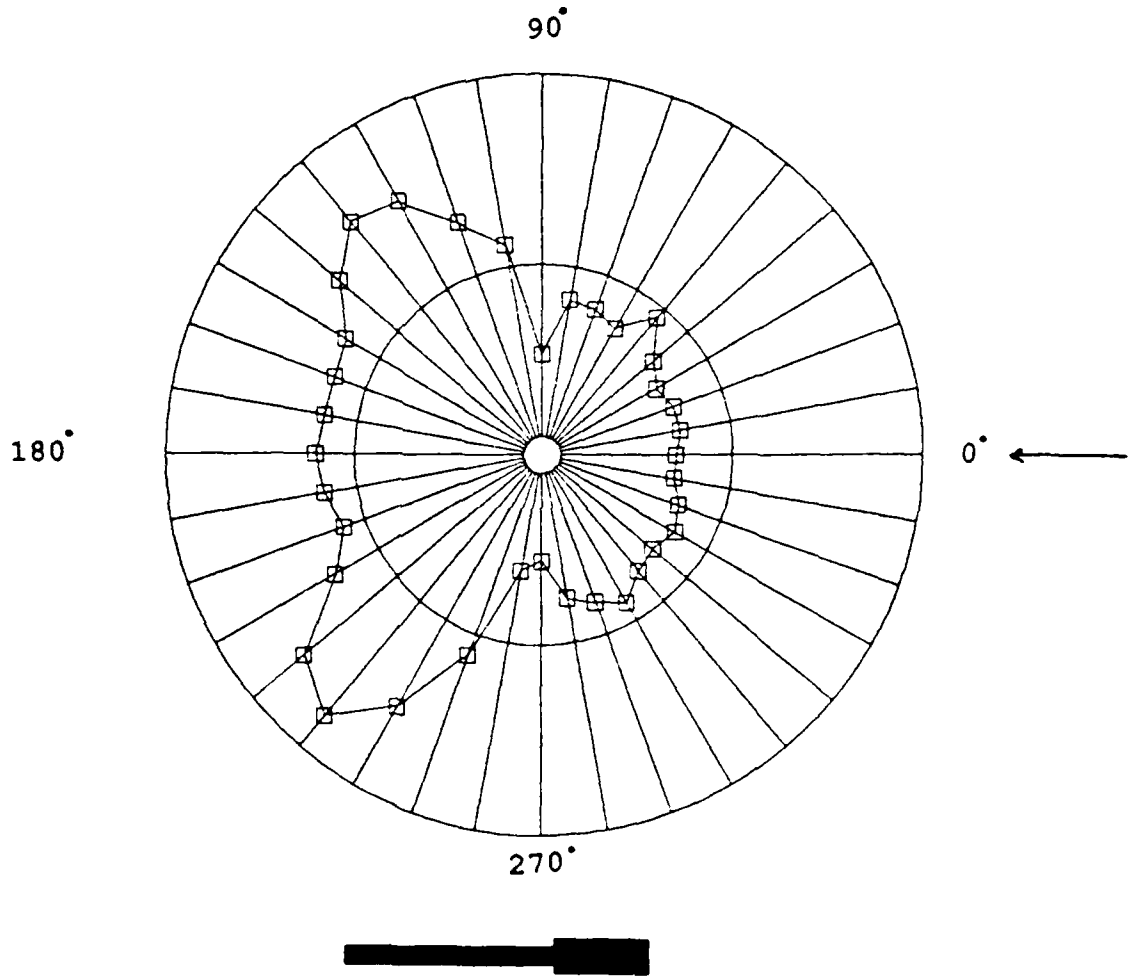

**Figure 16** Vertical Directivity Pattern of Hydrophone No.1, 80 kHz.

DIRECTIVITY OF HYDROPHONE

FREQUENCY = 100 KHZ

HYDROPHONE NO. 1

VERTICAL

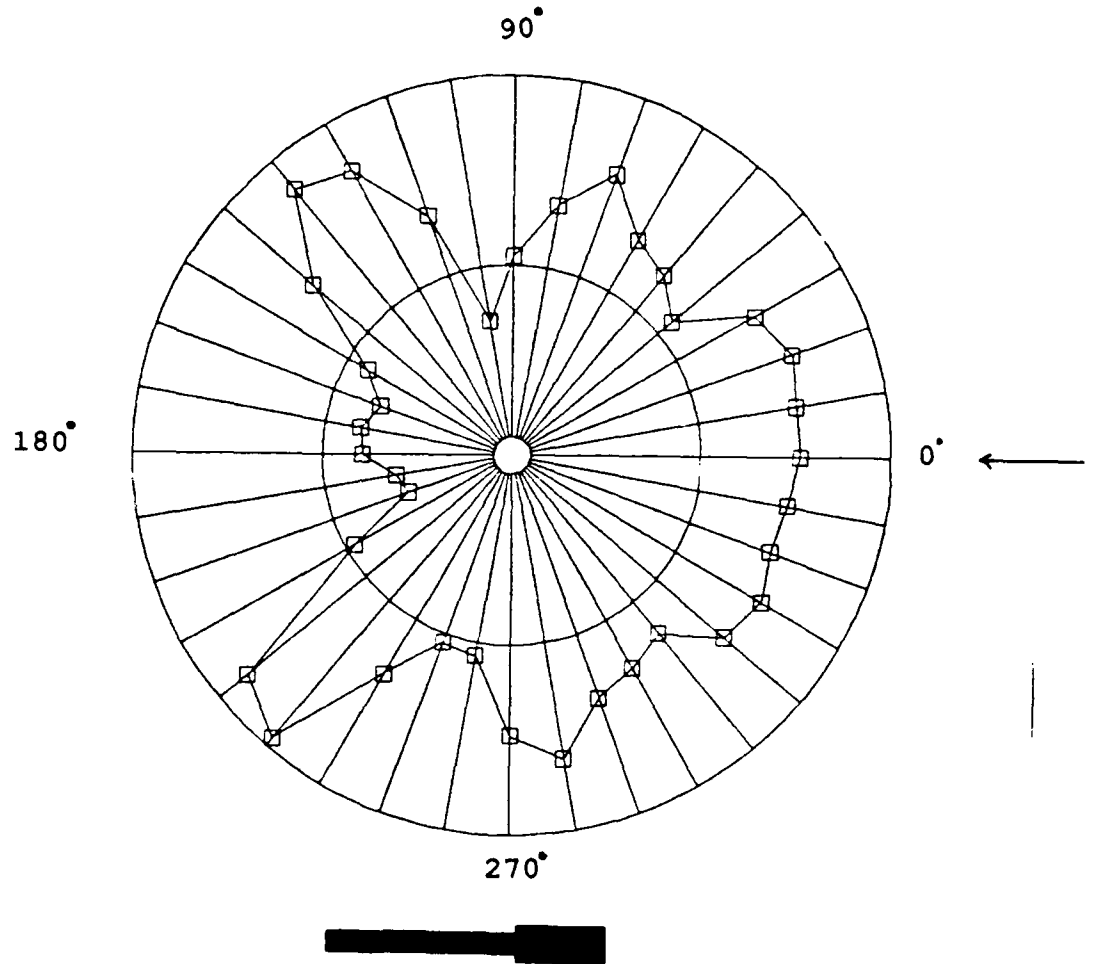

**Figure 17** Vertical Directivity Pattern of Hydrophone No.1, 100 kHz.

# DIRECTIVITY OF HYDROPHONE

FREQUENCY = 30 KHZ  
HYDROPHONE NO. 2  
VERTICAL

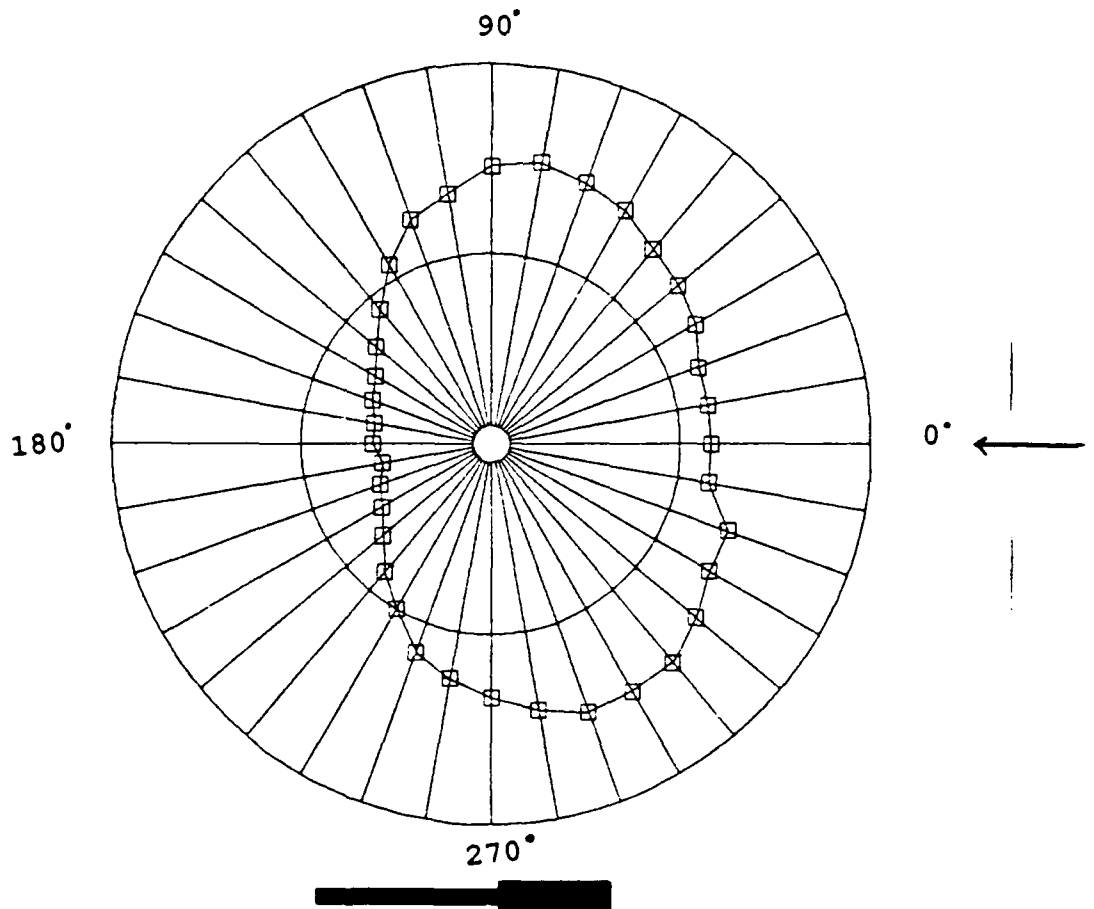

Figure 18 Vertical Directivity Pattern of Hydrophone No.2, 30 kHz.

# DIRECTIVITY OF HYDROPHONE

FREQUENCY = 50 KHZ

HYDROPHONE NO. 2

VERTICAL

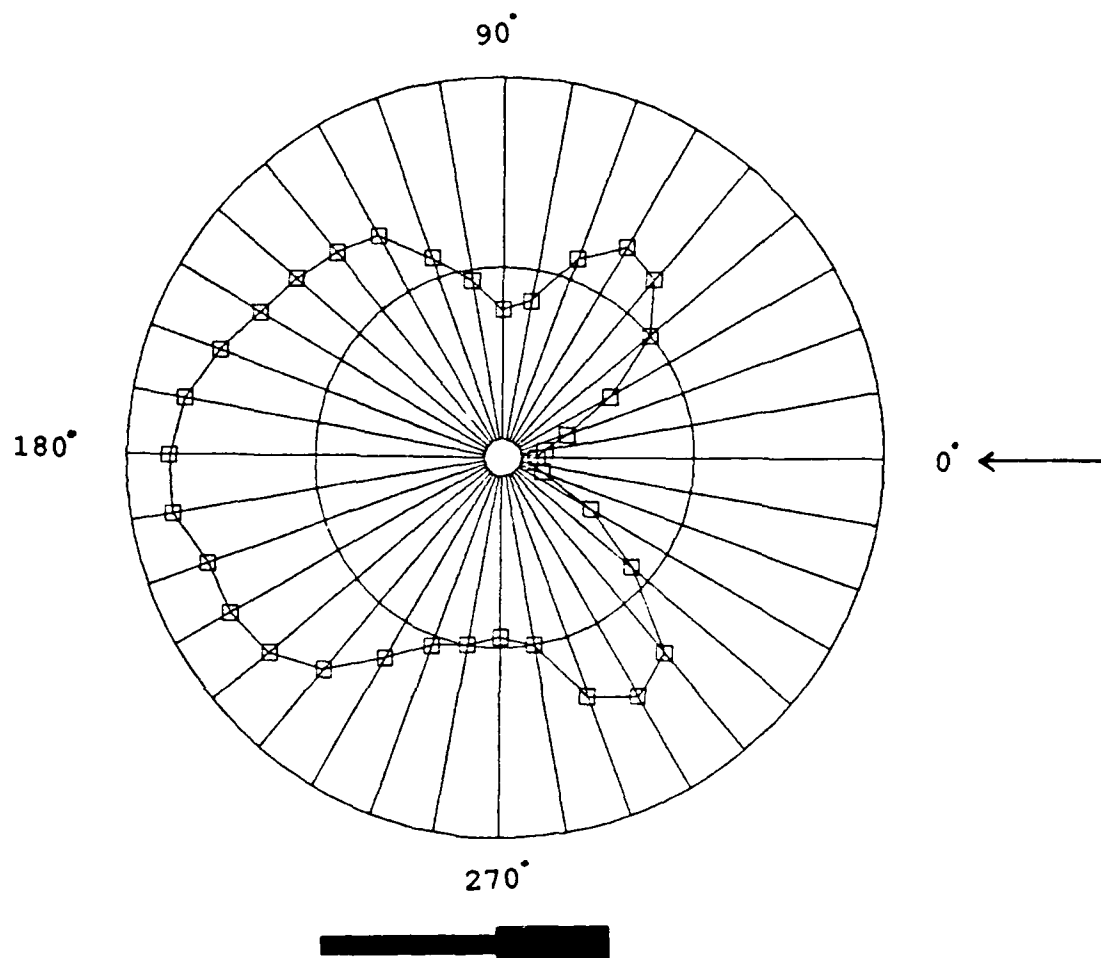

**Figure 19** Vertical Directivity Pattern of Hydrophone No.2 50 kHz.

DIRECTIVITY OF HYDROPHONE

FREQUENCY = 80 KHZ

HYDROPHONE NO. 2

VERTICAL

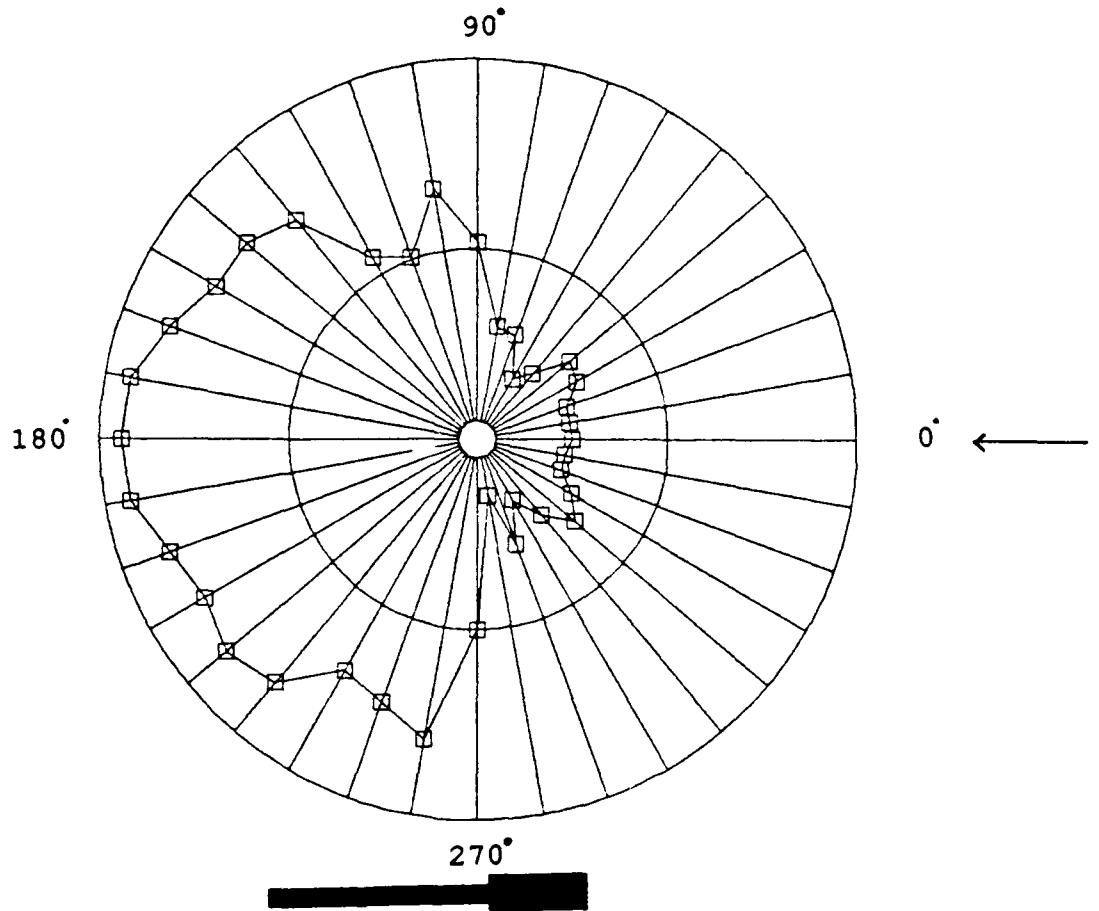

Figure 20 Vertical Directivity Pattern of Hydrophone No.2, 80 kHz.

DIRECTIVITY OF HYDROPHONE

FREQUENCY = 100 KHZ

HYDROPHONE NO. 2

VERTICAL

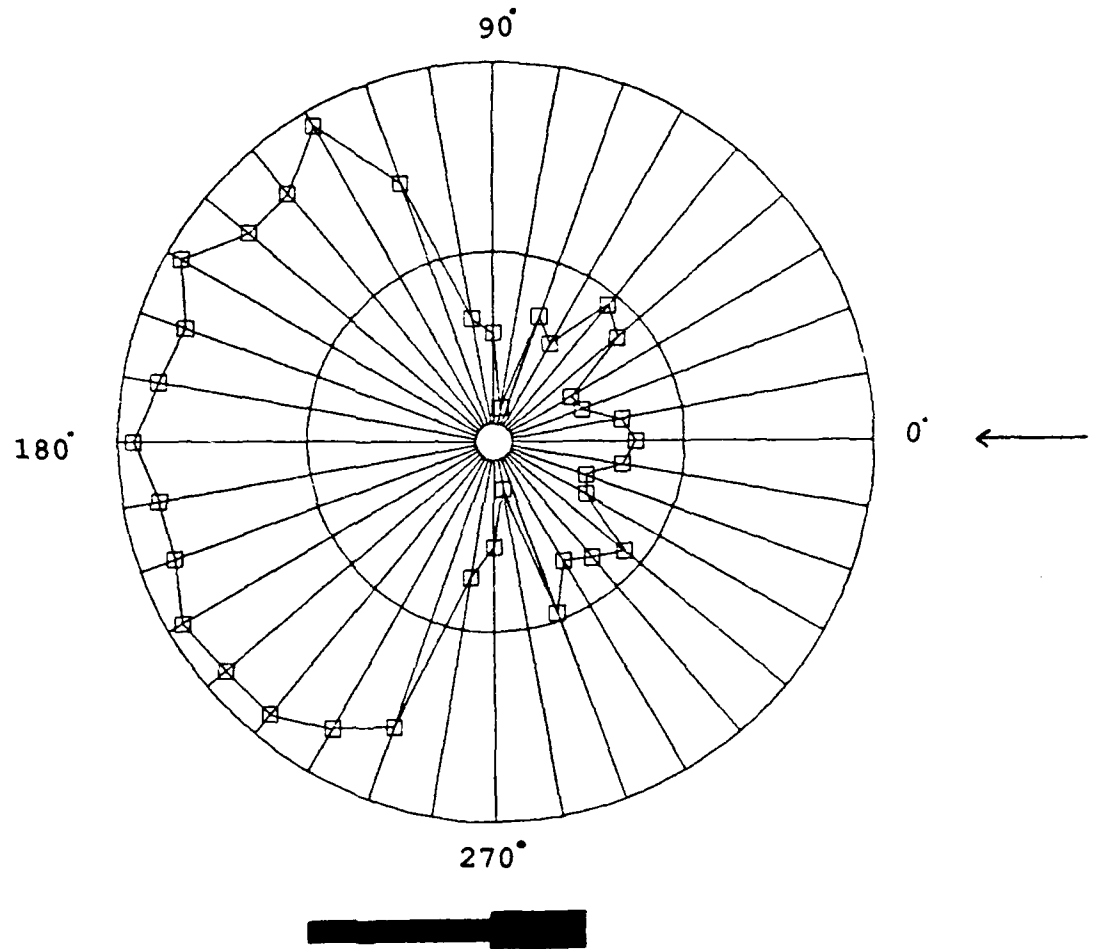

**Figure 21** Vertical Directivity Pattern of Hydrophone No.2, 100 kHz.

Eliminating Air Bubbles in the Water-Sand Mixture

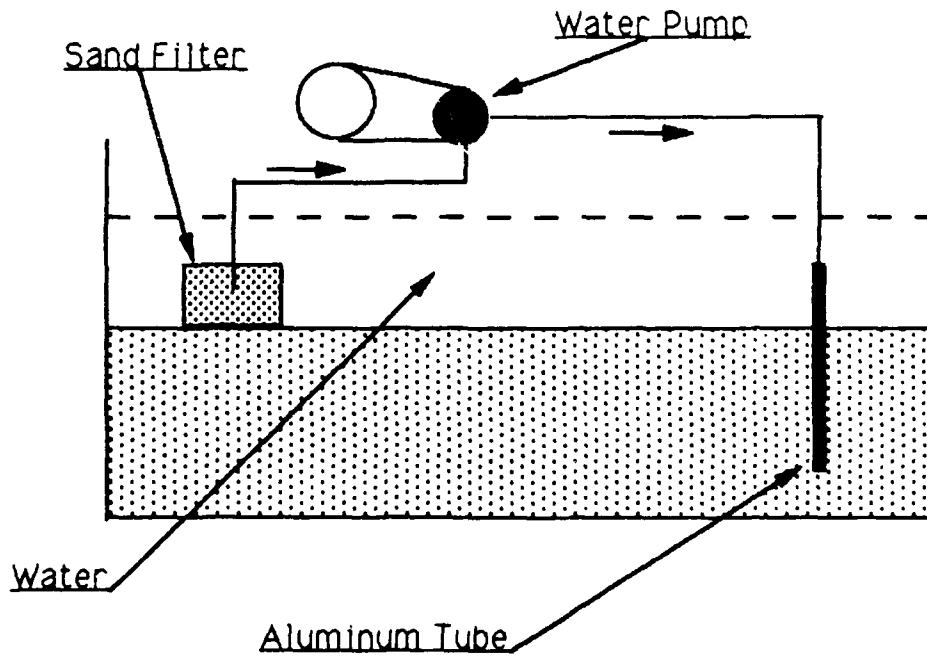
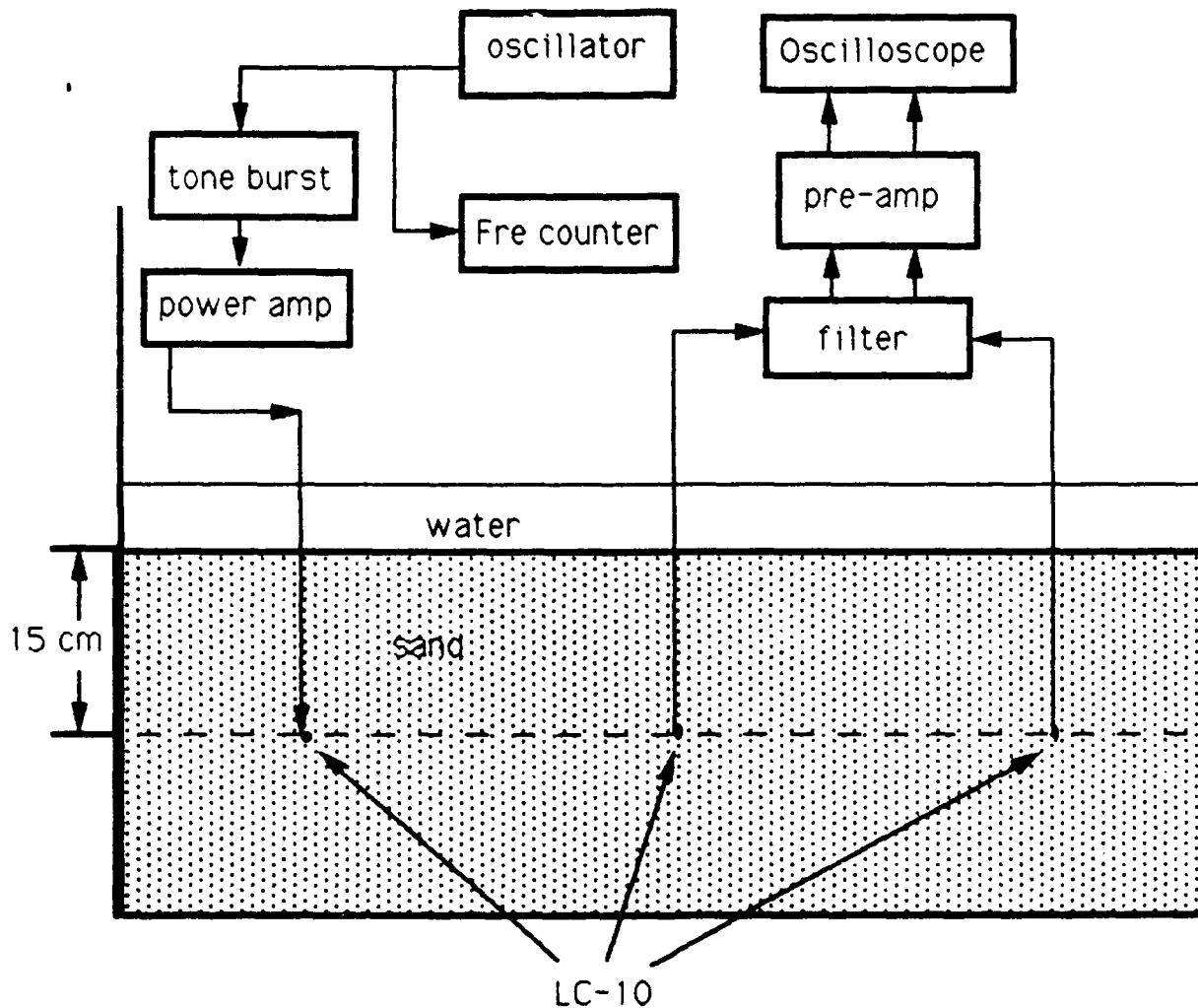

Figure 22 Eliminating Air Bubbles in the Water-Sand Mixture.

# Measurement of the Speed of Sound

IN

## Water-Saturated Sand & Water



**Figure 23** Measurement of the Speed of Sound in Water-Saturated Sand & Water.

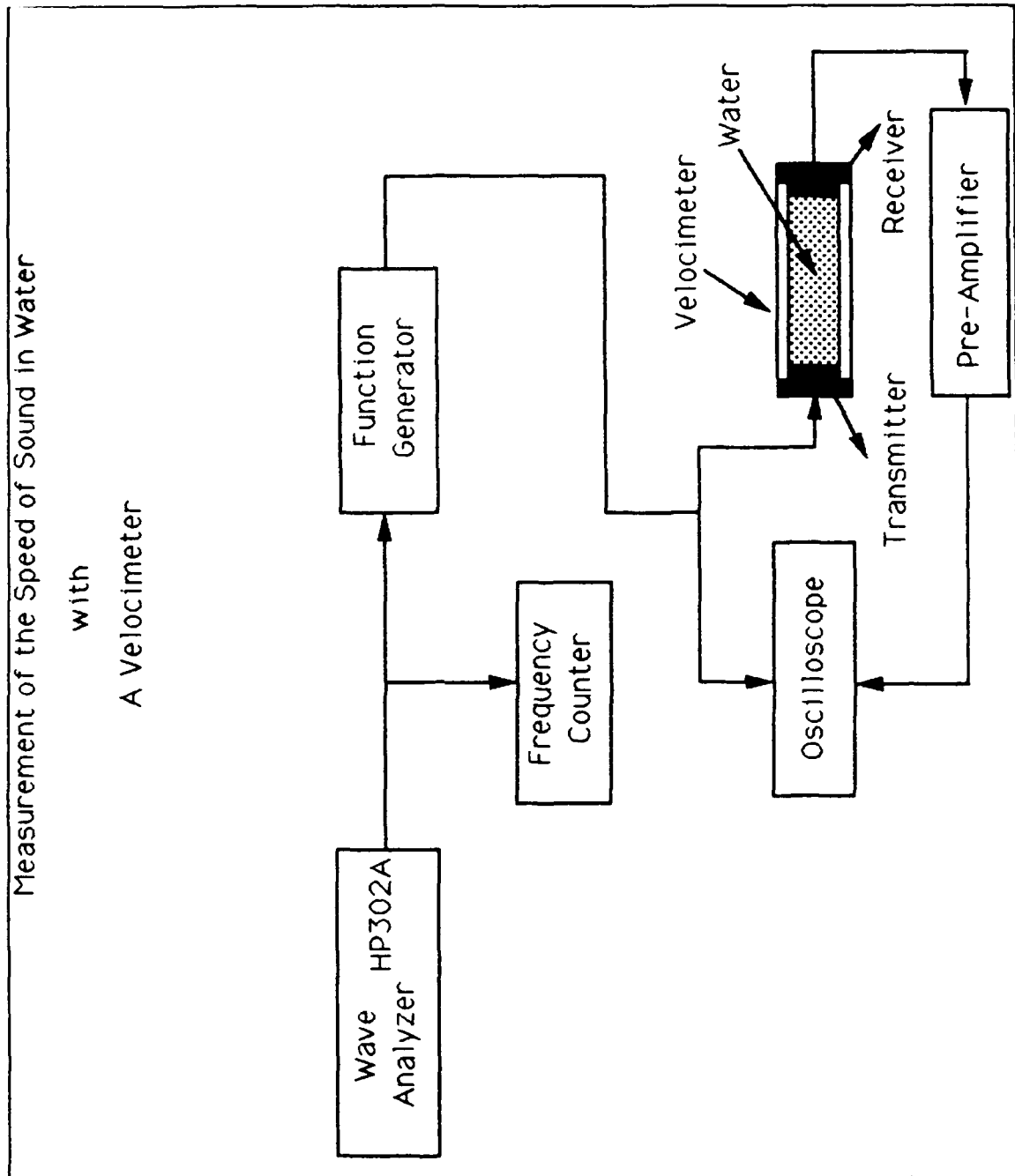

**Figure 24** Measurement of the Speed of Sound in Water with Velocimeter.

Measurement Reflection Coefficient  
of  
Water -Saturated Sand

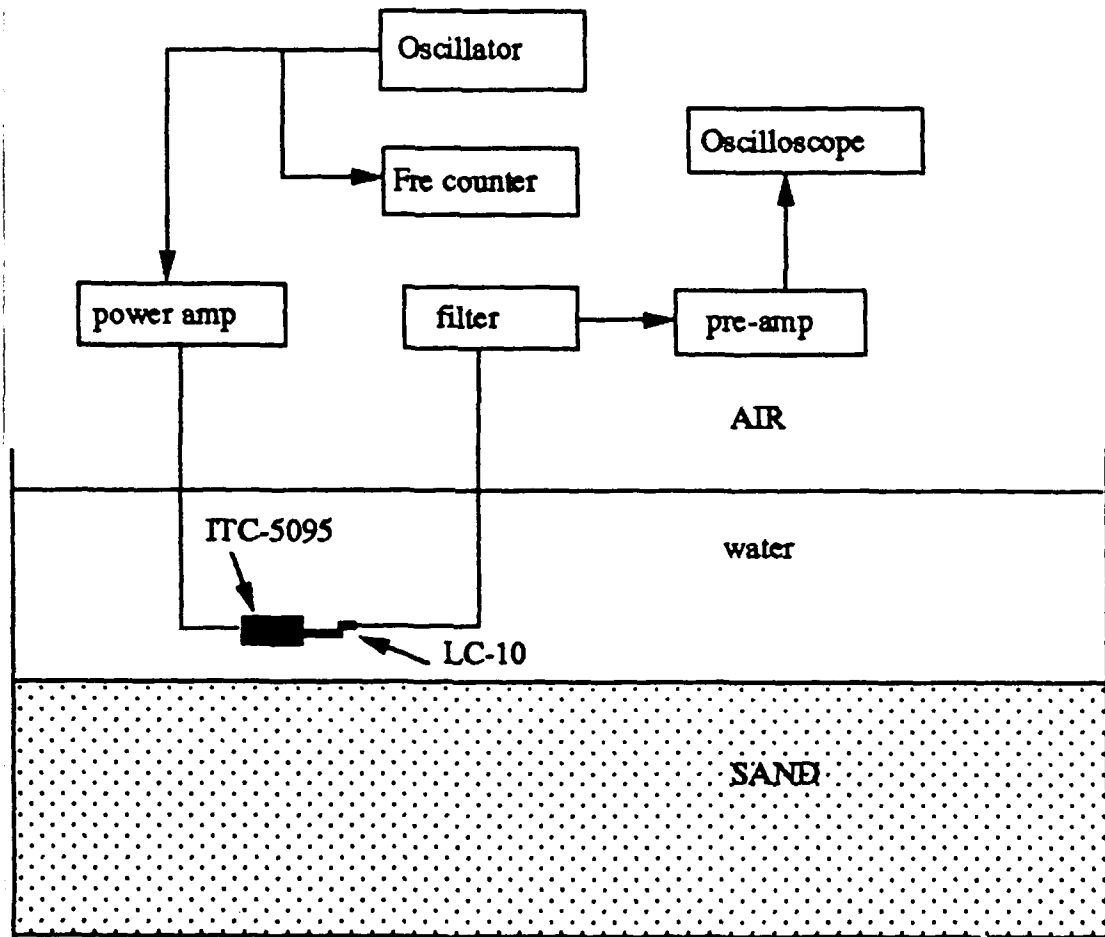

Figure 25 Measurement of the Reflection Coefficient of Water-Sand Mixture.

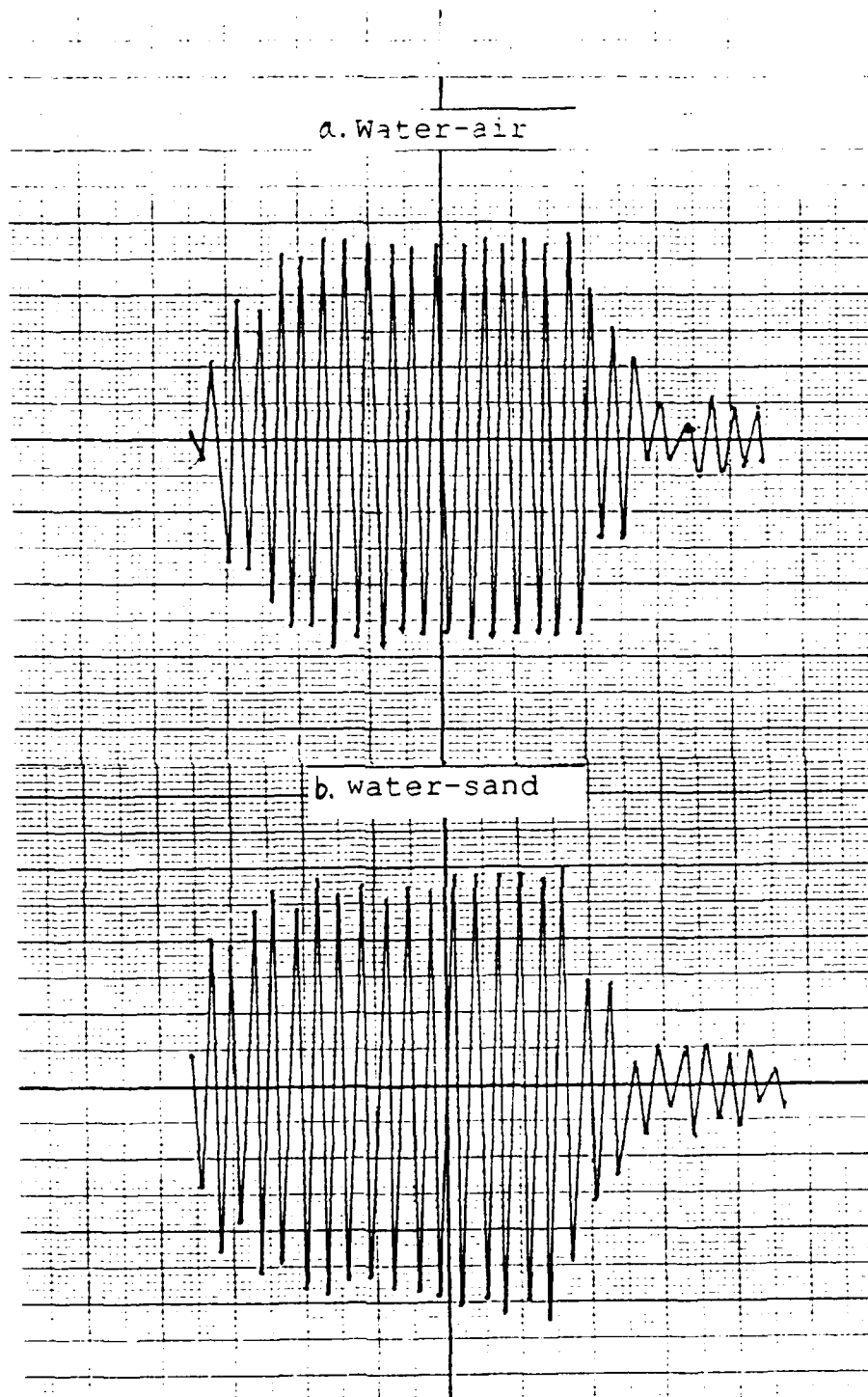

Figure 26 Reflected Waveform a) Water-Air b) Water-Sand.

CUTOFF FREQUENCY OF SHALLOW WATER  
 $C1 = 1505 \text{ M/S}$   $C2 = 1680 \text{ M/S}$   
 EXPERIMENT VS. THEORETICAL  
 FIRST MODE

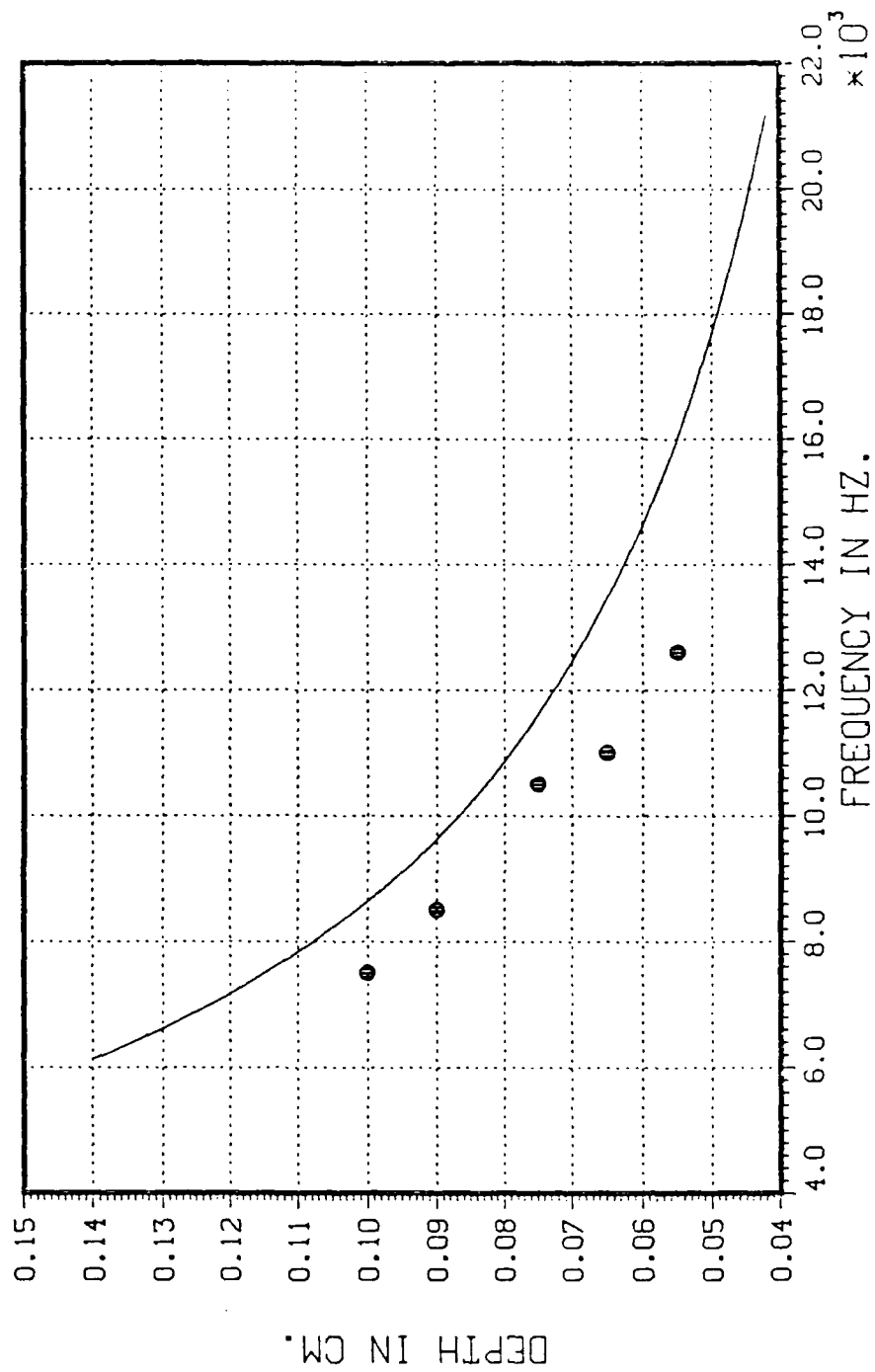
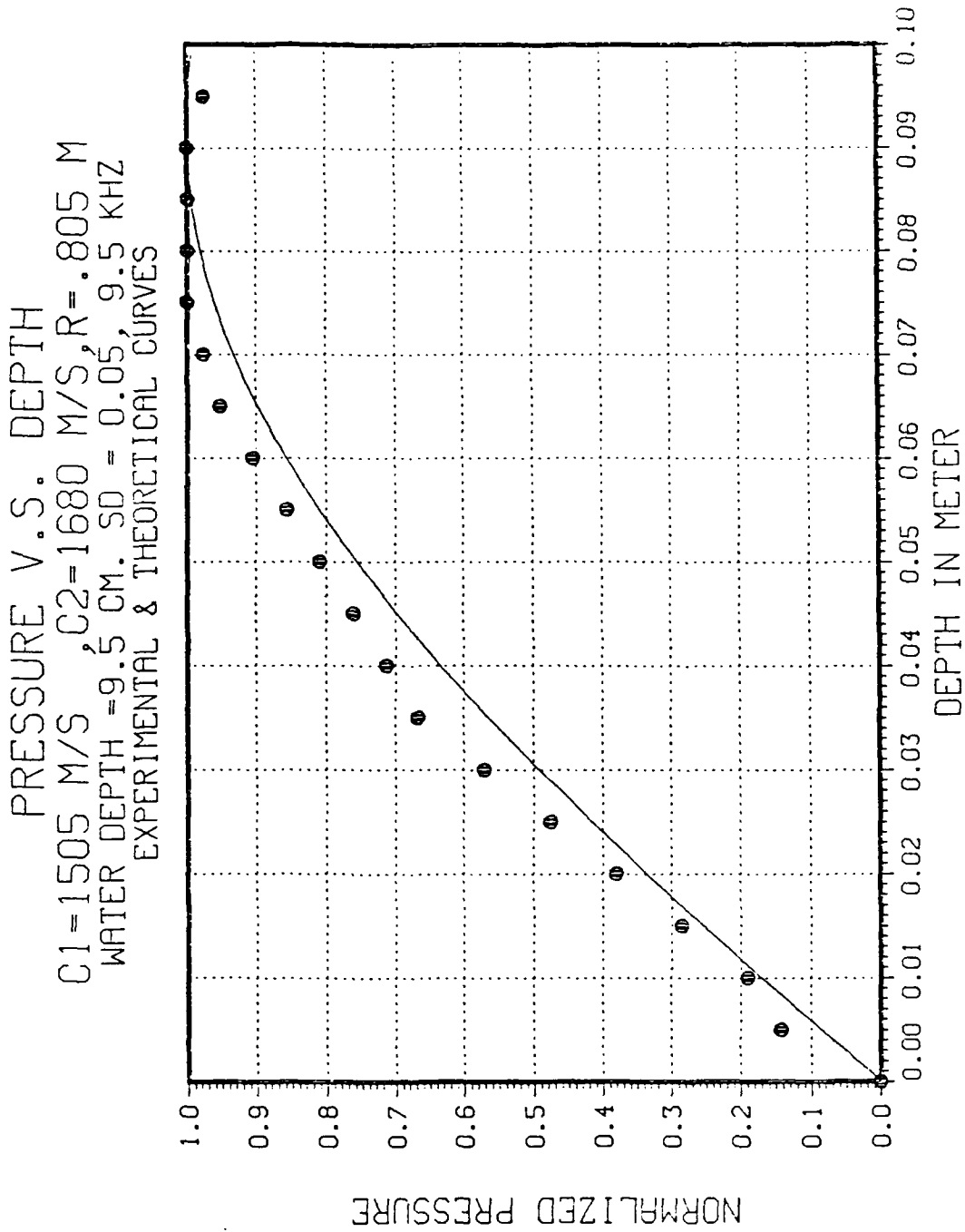

Figure 27 Theoretical & Experimental Normal-Mode Cutoff Frequency, First Mode.



**Figure 28** Sound Pressure in Water Layer,  $n=1$ , 9.5 kHz.

PRESSURE V.S. DEPTH  
 $C1=1505$  M/S,  $C2=1680$  M/S,  $R=.805$  M  
 WATER DEPTH = 9.5 CM. SD = 0.05, 15 KHZ  
 EXPERIMENTAL & THEORETICAL CURVES

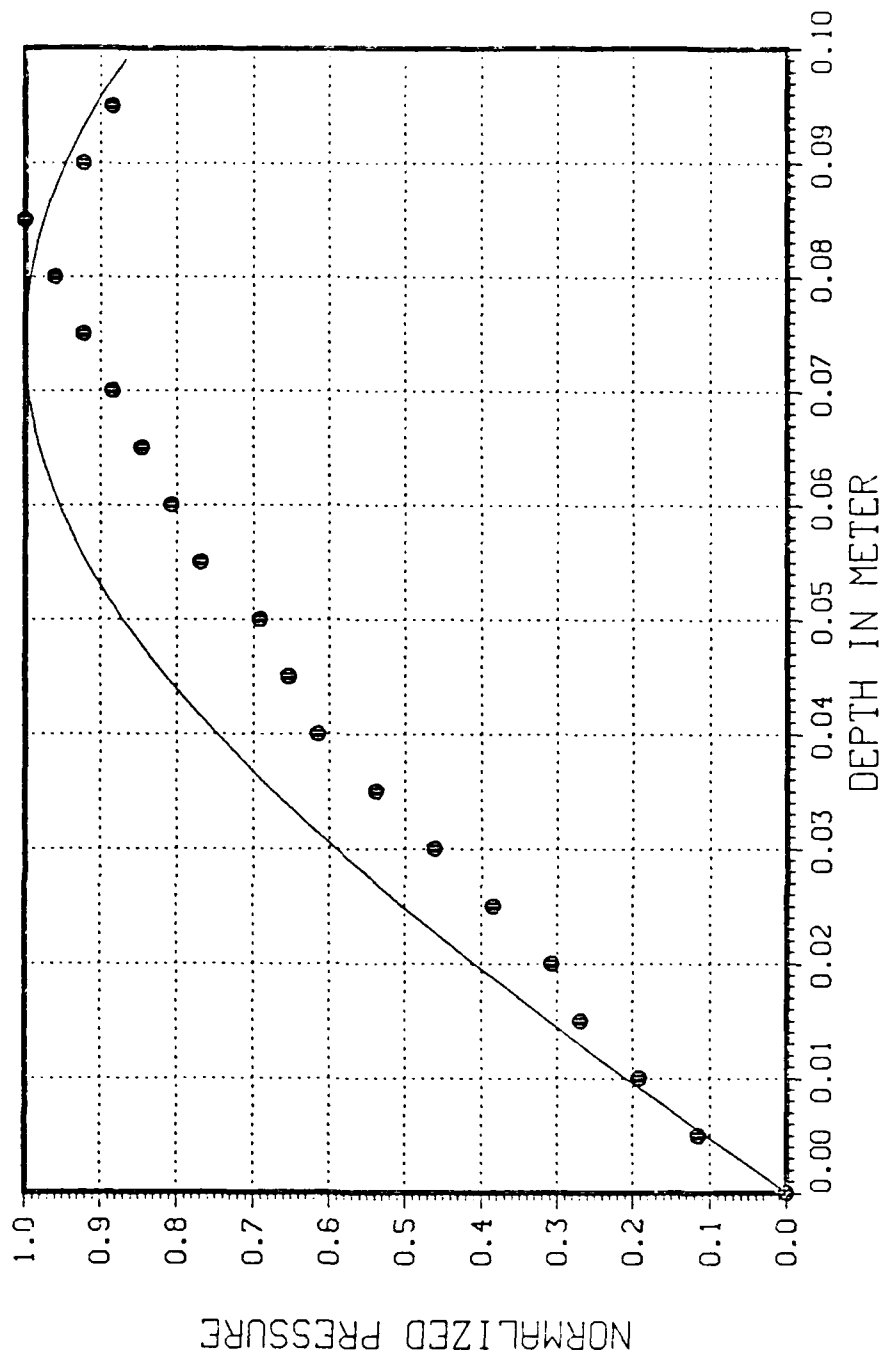

Figure 29 Sound Pressure in Water Layer,  $n = 1$ , 15 kHz.

PRESSURE V.S. DEPTH  
 $C1 = 1505 \text{ M/S}$ ,  $C2 = 1680 \text{ M/S}$ ,  $R = .805 \text{ M}$   
 WATER DEPTH =  $9.5 \text{ CM}$ .  $SD = 0.05$ ,  $18 \text{ KHZ}$   
 EXPERIMENTAL & THEORETICAL CURVES

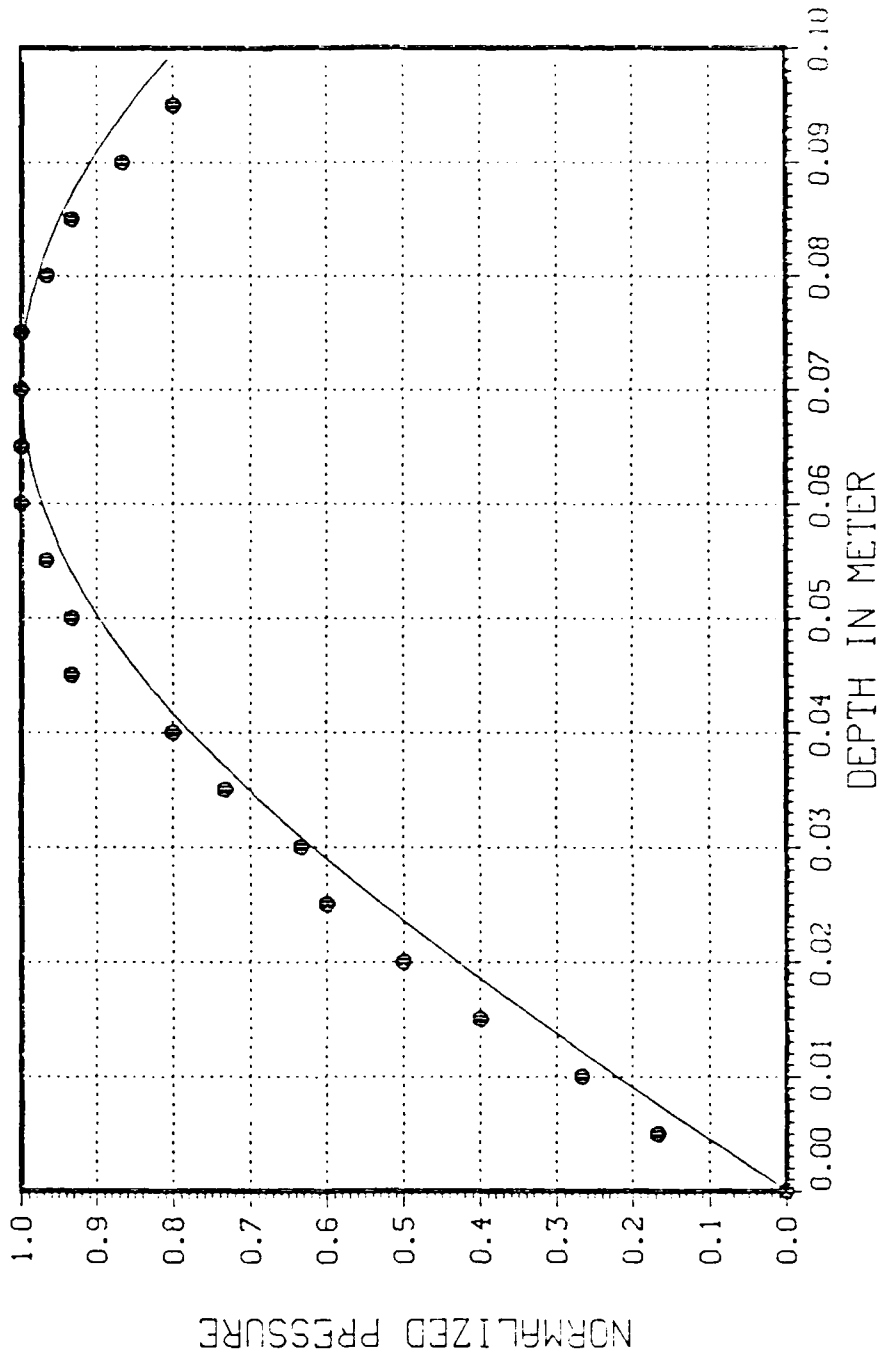

Figure 30 Sound Pressure in Water Layer,  $n = 1$ ,  $18 \text{ kHz}$ .

PRESSURE V.S. DEPTH  
 C1=1505 M/S, C2=1680 M/S, R=.805 M  
 WATER DEPTH =9.5 CM. SD = 0.05, 20 KHZ  
 EXPERIMENTAL & THEORETICAL CURVES

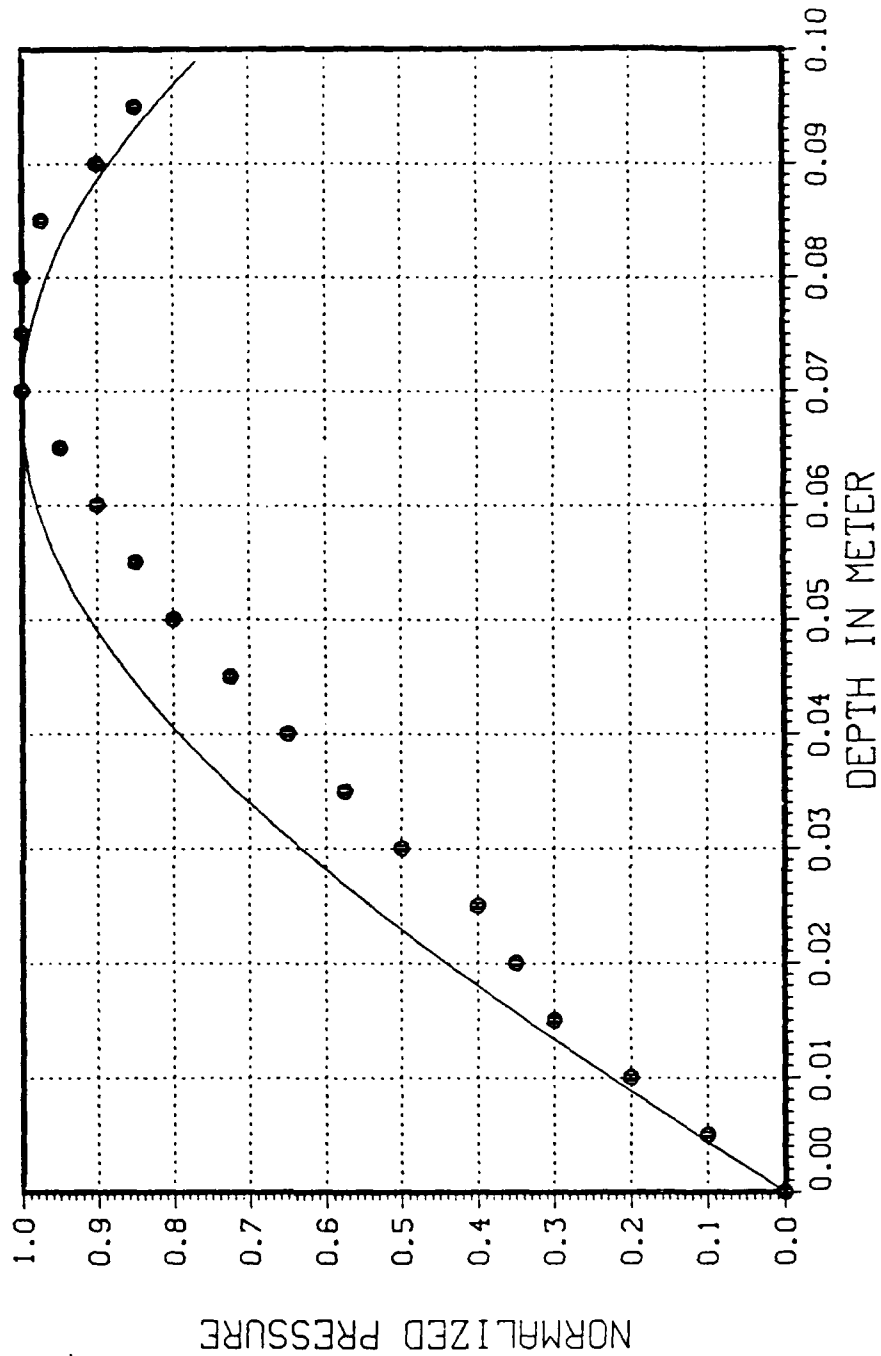

Figure 31 Sound Pressure in Water Layer, n = 1, 20 kHz.

PRESSURE V.S. DEPTH  
 C1=1505 M/S, C2=1680 M/S, R=.580 M  
 WATER DEPTH =9.5 CM. SD = 0.030, 30 KHZ  
 EXPERIMENTAL & THEORETICAL CURVES

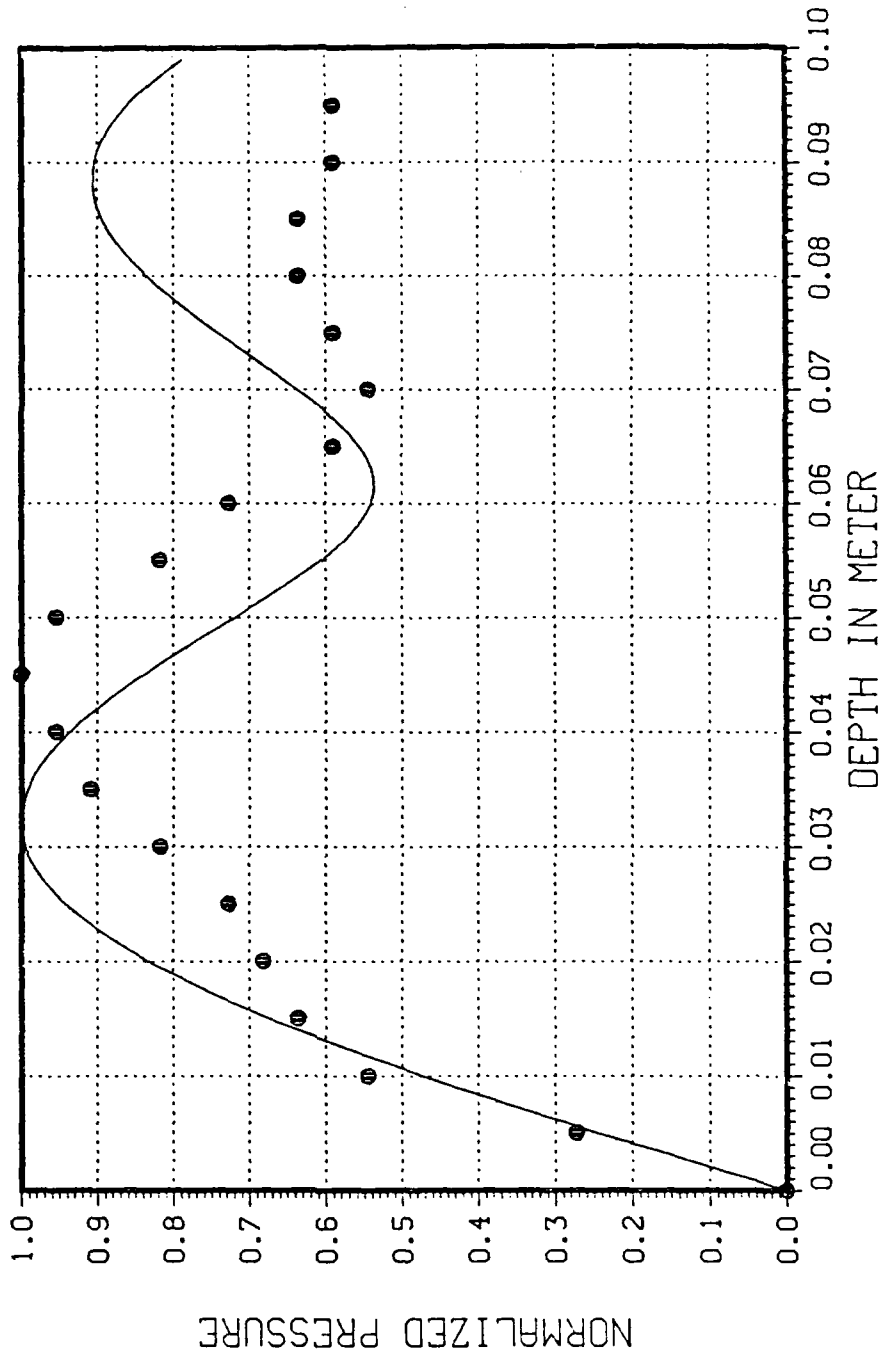

Figure 32 Sound Pressure in Water Layer, n = 2, 30 kHz.

PRESSURE V.S. DEPTH  
 $C1=1505$  M/S,  $C2=1680$  M/S,  $R=.580$  M  
 WATER DEPTH  $=9.5$  CM.  $SD = 0.030$ ,  $35$  KHZ  
 EXPERIMENTAL & THEORETICAL CURVES

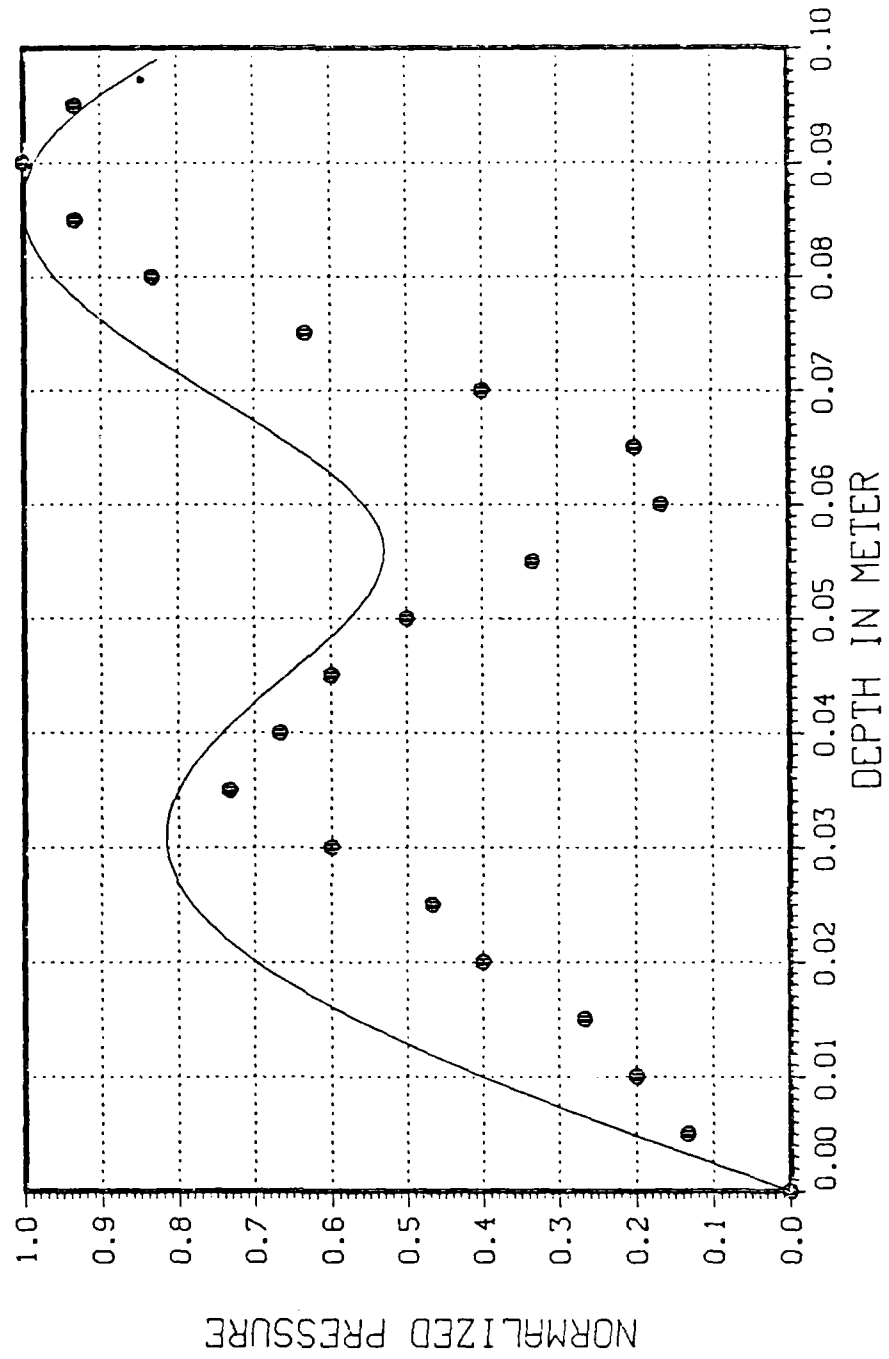

Figure 33 Sound Pressure in Water Layer,  $n = 2$ ,  $35$  kHz.

PRESSURE V. S. DEPTH  
 $C1=1505$  M/S,  $C2=1680$  M/S,  $R=.580$  M  
 WATER DEPTH  $=9.5$  CM. SD =  $0.030$ ,  $40$  KHZ  
 EXPERIMENTAL & THEORETICAL CURVES

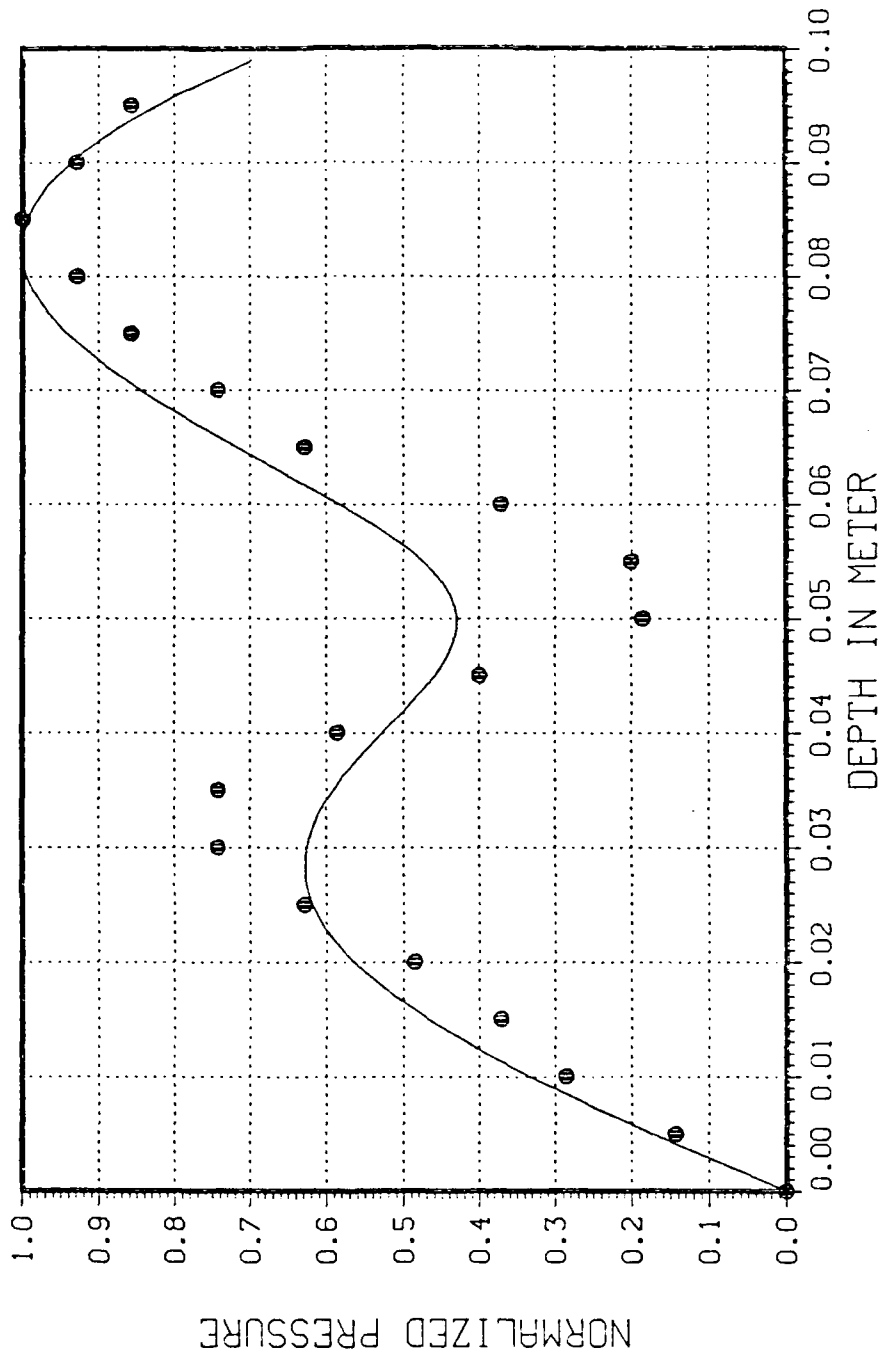
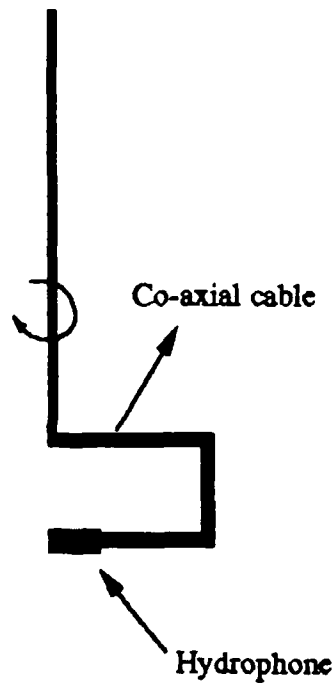

Figure 34 Sound Pressure in Water Layer,  $n = 2$ ,  $40$  kHz.

a) Position of Hydrophone  
for  
Vertical Directivity Pattern



b) Aluminum Blade

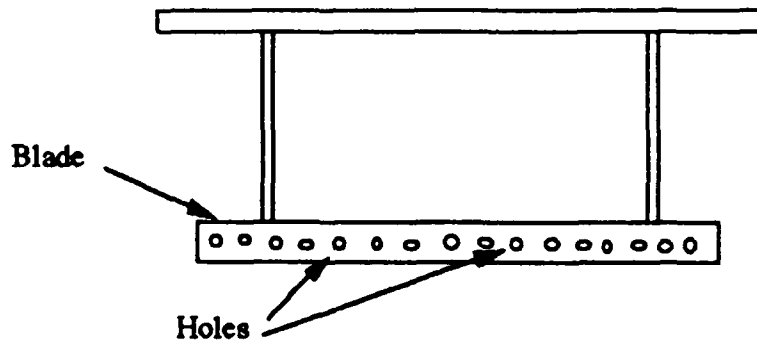
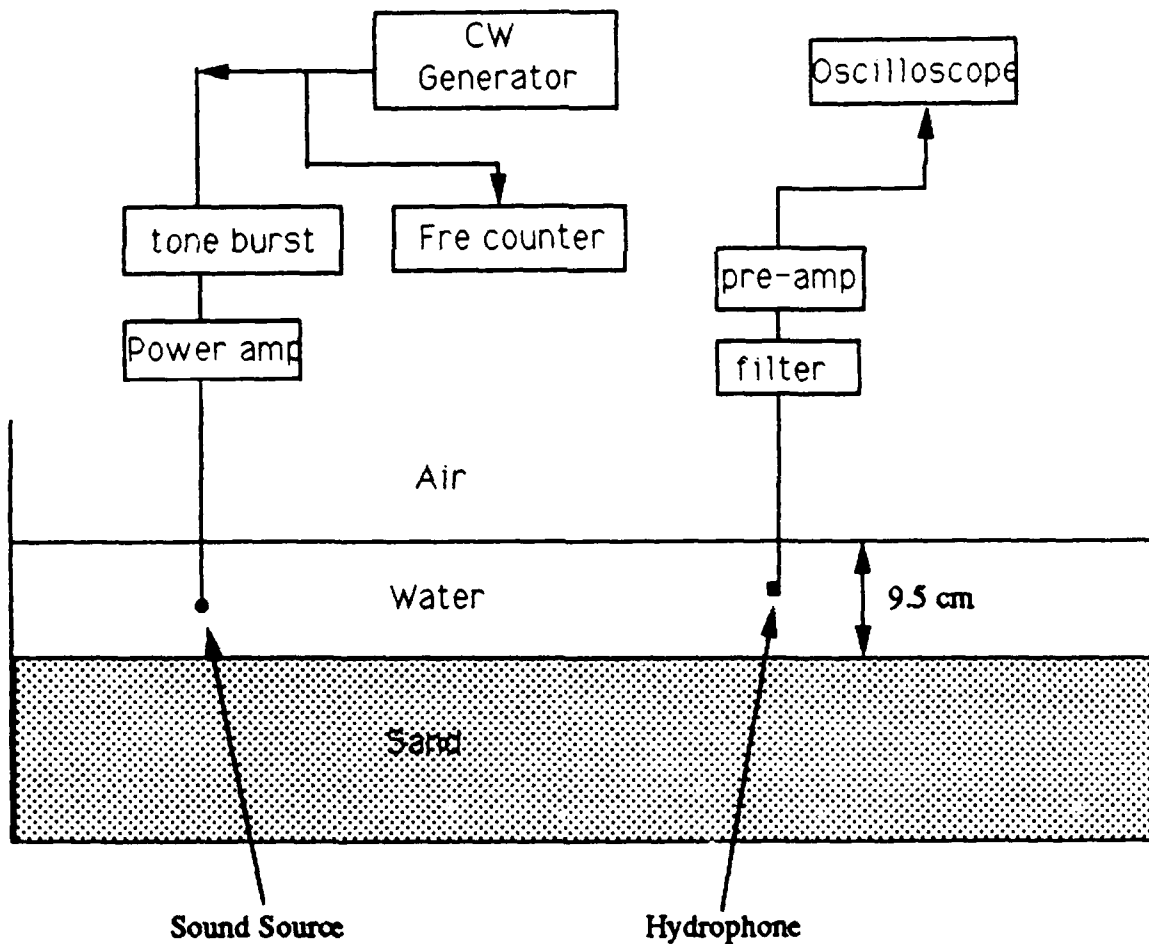

Figure 35 a) Position of Hydrophone for Vertical Directivity Pattern Measurement b) Aluminum Blade.

Equipment Set Up for Measurement Sound Pressure  
In  
Water Layer



**Figure 36** Equipment Set Up for Measurement Sound Pressure in Water Layer.

# SOUND SPEED IN WATER

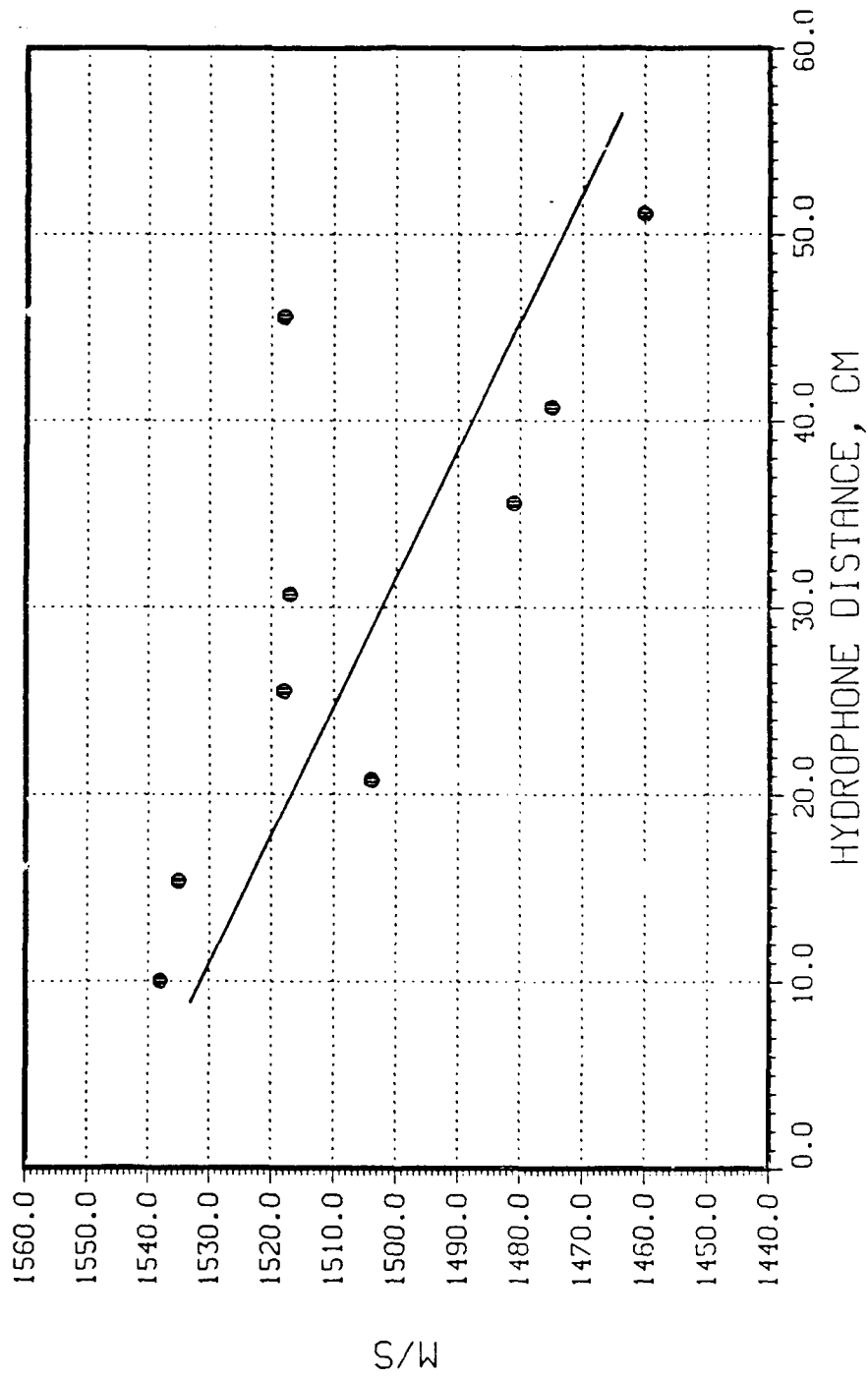

Figure 37 Speed of Sound in Water vs. Hydrophone Distance

### LIST OF REFERENCES

1. Tariq, M., and Rungsirrotekomol, S., Propagation of Sound in a Layered Laboratory Model, M.S. Thesis, Naval Postgraduate School, Monterey, CA, 1984.
2. LeBlanc, L.C., Handbook of Hydrophone Element Design Technology, Naval Underwater Systems Center, New London Laboratory, CT, 1984.
3. Wilson, O.B., An Introduction to Theory and Design of Sonar Transducer, U.S. Government Printing Office, 1985.
4. Channel Industrial, Inc., Catalog Number 761-01, Address: 839 Ward Drive, Santa Barbara, CA 93111, 1989.
5. Lange, N.A., Handbook of Chemistry, p 1199, McGraw-hill Book Company, 1967.
6. Bradshaw, J.A., Laboratory Study of Sound Propagation into a Fast Bottom Medium, M.S. Thesis, Naval Postgraduate School, Monterey, CA, 1984.
7. Urick, R.J., Sound Propagation in the sea, Defence Advanced Research Projects Agency, p. 10-4, 1979.
8. Anderson, O.L., and Liebermann, R.C., "Sound Velocities in Rock and Minerals", in Physical Acoustics, IV-B, Edited by W.P. Mason, Academic Press, 1968.
9. Hamilton, E.L., "Sound Velocity, Elasticity, and Related Properties of Marine Sediments, North Pacific", Naval Undersea Research and Development Center Technical Publication No.143, V.1, p.9-13, October 1969.
10. Kinsler, L.E., Frey, A.R., Coppens, A.B., and Sanders, J.V., Fundamentals of Acoustics, Wiley & Sons, Inc., 1982.