

AD-A225 421

Tactical Flexibility: Where? Why?

A Monograph
by

Major Anthony S. Lieto

Armor

DTIC
ELECTE
AUG 21 1990
S D D
ca



School of Advanced Military Studies
United States Army Command and General Staff College
Fort Leavenworth, Kansas

First Term AY 89/90

Approved for Public Release; Distribution is Unlimited

90-3176

90 08 20 045

REPORT DOCUMENTATION PAGE

Form Approved
OMB No. 0704-0188

1a. REPORT SECURITY CLASSIFICATION UNCLASSIFIED	1b. RESTRICTIVE MARKINGS
2a. SECURITY CLASSIFICATION AUTHORITY	3. DISTRIBUTION / AVAILABILITY OF REPORT Approved for public release; distribution unlimited
7b. DECLASSIFICATION / DOWNGRADING SCHEDULE	
4. PERFORMING ORGANIZATION REPORT NUMBER(S)	5. MONITORING ORGANIZATION REPORT NUMBER(S)

6a. NAME OF PERFORMING ORGANIZATION School of Advanced Military Studies, USAC&GSC	6b. OFFICE SYMBOL (If applicable) ATZL-SWV	7a. NAME OF MONITORING ORGANIZATION
--	--	-------------------------------------

6c. ADDRESS (City, State, and ZIP Code) Fort Leavenworth, Kansas 66027-6900	7b. ADDRESS (City, State, and ZIP Code)
--	---

8a. NAME OF FUNDING / SPONSORING ORGANIZATION	8b. OFFICE SYMBOL (If applicable)	9. PROCUREMENT INSTRUMENT IDENTIFICATION NUMBER
---	--------------------------------------	---

8c. ADDRESS (City, State, and ZIP Code)	10. SOURCE OF FUNDING NUMBERS			
	PROGRAM ELEMENT NO.	PROJECT NO.	TASK NO.	WORK UNIT ACCESSION NO.

11. TITLE (Include Security Classification)
Tactical Flexibility: Where? Why? (U)

12. PERSONAL AUTHOR(S)
MAJ Anthony S. Lieto, USA

13a. TYPE OF REPORT Monograph	13b. TIME COVERED FROM _____ TO _____	14. DATE OF REPORT (Year, Month, Day) 89/12/19	15. PAGE COUNT 64
----------------------------------	--	---	----------------------

16. SUPPLEMENTARY NOTATION

17. COSATI CODES			18. SUBJECT TERMS (Continue on reverse if necessary and identify by block number) Force Structure, Division ^{LEVEL} Organizations; Force Design; Brigade Support; Brigade ^{LEVEL} Organizations; Tactical Organization
FIELD	GROUP	SUB-GROUP	

19. ABSTRACT (Continue on reverse if necessary and identify by block number)

This monograph examines the development of tactical organizations and where organizational flexibility was structured and why it was focused there. The 1986 version of FM 100-5 OPERATIONS focuses on the corps as the U.S. Army's largest tactical formation. With the current corps filling some of the roles of the WW II field army, and the division and brigade structures not similarly evolving, it appears there exists a void which was filled by the WW II corps. Additionally, tactical dynamics on the battlefield have significantly changed since the adoption of the fixed division, flexible brigade concept.

The monograph begins with a theoretical examination of tactical flexibility and organizational structure. A historical study of how the U.S. Army achieved tactical flexibility through the organizational structure of the division follows. This historical study examines how the U.S. Army's divisional organization has changed from WW I to the ROAD organization (fixed division, flexible brigade) used today, with an emphasis on the structure of tactical flexibility.

-CONTINUED ON BACK-

20. DISTRIBUTION / AVAILABILITY OF ABSTRACT <input checked="" type="checkbox"/> UNCLASSIFIED/UNLIMITED <input type="checkbox"/> SAME AS RPT. <input type="checkbox"/> DTIC USERS	21. ABSTRACT SECURITY CLASSIFICATION UNCLASSIFIED
22a. NAME OF RESPONSIBLE INDIVIDUAL MAJ Anthony S. Lieto	22b. TELEPHONE (Include Area Code) 22c. OFFICE SYMBOL (913) 684-3345 ATZL-SWV

The monograph continues with an analysis of the impact on tactical flexibility and the changes in doctrine, organizational structure above corps, training, technology, and threat since the adoption of the fixed division, flexible brigade organization. An alternative organization of a flexible division, fixed brigade is proposed. An analysis of each system is examined against an established set of criteria. The criteria include synchronization, agility, trainability, sustainability, and interoperability. This monograph examines the whole tactical organization of corps, division, brigade as a system rather than the traditional approach of fixed brigade vs. flexible brigade.

The monograph concludes that the flexible division, fixed brigade concept shows promise for future use. A test is proposed to examine each system in a real world environment where the fog and friction of war can enter into the evaluation.

SCHOOL OF ADVANCED MILITARY STUDIES

MONOGRAPH APPROVAL

Major Anthony S. Lieto

Title of Monograph: Tactical Flexibility: Where? Why?

Approved by:

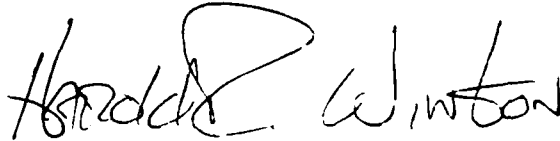

Harold R. Winton, Ph.D.

Monograph Director

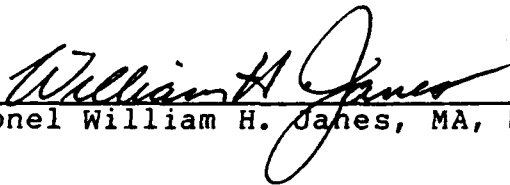

Colonel William H. James, MA, MMAS

Director, School of
Advanced Military
Studies

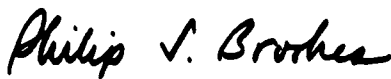

Philip J. Brookes, Ph.D.

Director, Graduate
Degree Program

Accepted this 26th day of March 1990

ABSTRACT

TACTICAL FLEXIBILITY: WHERE ? WHY ? by MAJ Anthony S. Lieto, USA, 64 pages.

This monograph examines the development of tactical organizations and where organizational flexibility was structured and why it was focused there. The 1986 version of FM 100-5 OPERATIONS focuses on the corps as the U.S. Army's largest tactical formation. With the current corps filling some of the roles of the WW II field army, and the division and brigade structures not similarly evolving, it appears there exists a void which was filled by the WW II corps. Additionally, tactical dynamics on the battlefield have significantly changed since the adoption of the fixed division, flexible brigade concept.

The monograph begins with a theoretical examination of tactical flexibility and organizational structure. A historical study of how the U.S. Army achieved tactical flexibility through the organizational structure of the division follows. This historical study examines how the U.S. Army's divisional organization has changed from WW I to the ROAD organization (fixed division, flexible brigade) used today, with an emphasis on the structure of tactical flexibility.

The monograph continues with an analysis of the impact on tactical flexibility and the changes in doctrine, organizational structure above corps, training, technology, and threat since the adoption of the fixed division, flexible brigade organization. An alternative organization of a flexible division, fixed brigade is proposed. An analysis of each system is examined against an established set of criteria. The criteria includes synchronization, agility, trainability, sustainability, and interoperability. This monograph examines the whole tactical organization of corps, division, brigade as a system rather than the traditional approach of fixed brigade vs. flexible brigade.

The monograph concludes that the flexible division, fixed brigade concept shows promise for future use. A test is proposed to examine each system in a real world environment where the fog and friction of war can enter into the evaluation.

Table of Contents

	Page
Approval Page	ii
Abstract	iii
I. Introduction	1
II. Theory	2
III. U.S. Army Tactical Organizations	7
IV. Changes Since ROAD Concept	22
V. Analysis	25
VI. Conclusions	35
VII. Implications	38
Appendixes	
Appendix A	40
Appendix B	42
Appendix C	46
Appendix D	48
Appendix E	50
Appendix F	52
Endnotes	54
Bibliography	56



Accession For	
NTIS CRA&I	<input checked="" type="checkbox"/>
DTIC TAB	<input type="checkbox"/>
Unannounced	<input type="checkbox"/>
Justification	
By	
Distribution/	
Availability Codes	
Dist	Avail and/or Special
A-1	

The 1986 version of FM 100-5 Operations has focused attention on the corps as the U.S. Army's largest tactical organization. In some respects, the present day corps has replaced the traditional role of the field army of World War II. The modern day corps is unlike the corps of the past. During World War II, the corps was simply a tactical headquarters and the field army provided the necessary administrative and logistical support for the subordinate divisions. "Today's corps is now responsible for providing administrative and logistic support for subordinate units." However, the division and brigade structures have not similarly evolved. With the current corps filling some of the roles of the World War II field army, it appears there exists a void which was filled by the World War II corps, in that there no longer exists a tactically flexible headquarters at the higher tactical echelons.

Additionally, tactical dynamics on the battlefield have significantly changed since the completion of the Reorganization Objective Army Division (ROAD) '62. The "fixed division, flexible brigade" concept, is still the organizational structure used by the U.S. Army today. "The current complexities of Army division design can be traced back to 1962 and the ROAD concept." Changes in training, doctrine, and materiel developments have all influenced how the U.S. Army plans to fight at the higher tactical levels. A key issue generated by the changes in the corps' structure, functions, and the tactical

dynamics mentioned above is at what level should the U.S. Army structure tactical flexibility?

The methodology to answer this question begins with a theoretical examination of tactical flexibility and organizational structures. There follows a historical examination of U.S. Army's tactical organizations from World War I to the adoption of the ROAD concept. This analysis will focus on where tactical flexibility was structured, what influenced these organizations to change, and the implications of these changes toward tactical flexibility. The next section examines changes that have occurred since the adoption of the "fixed division, flexible brigade" concept. The analysis will suggest an alternative organization and compare in detail each alternative within its corps, division and brigade context. This analysis will lead to a conclusion which organization best meets the Army's needs. The final section provides implications for future studies concerning tactical flexibility.

II. THEORY

We should establish one battle-order, the arrangement of troops before and during combat,... this battle array will introduce a certain uniformity... which will be useful and advantageous.

Carl von Clausewitz

The right tactical organization is the foundation on which armies have always sought to build their structure, but has remained as illusive as the Holy Grail. Jomini sets his second

of twelve conditions for making a perfect army as, "having a good organization."³ He further states that, "none of these twelve conditions can be neglected without grave inconvenience."⁴

An organization should provide a certain amount of flexibility and combined arms to the tactical commander. The Roman Legion, provided excellent flexibility to the legion commander. According to FM 100-5, Operations, "The need for flexibility is greater for the committed maneuver unit commander than for anyone else." An organization which provides excellent command and control and retains tactical flexibility must also have some sort of combined arms to be truly useful, especially when it might fight independently. "Combined arms are therefore desirable to say the least, for any unit that frequently finds itself operating in isolation."⁵ The Roman Legion organized into centuries, maniples, and cohorts consisting of archers, slingers, light-armored foot, heavy-armored foot and cavalry was a fine combined arms organization. The Roman Legion provided excellent flexibility and combined arms capability to the committed legion commander, and still would be a good organization if armies were fighting unorganized Visigoths.

Organizing for combat historically depended on how an army intended to fight, where an army intended to fight and who an army intended to fight.⁶ Since these three requirements change frequently, so do tactical organizations. The how, when and where of choosing an organization depends on the right mix of mass and mobility (maneuver). "Maneuver theory is about amplifying the force which a small mass is capable of

exerting... on the other hand this mass, however small, must be capable of conveying enough physical fighting power to offer a threat..."⁷ Historically, choosing the correct mix of mass and mobility ensures that an organization maintains flexibility. Brigadier General Richard Simpkin makes the point that maintaining a mix of mass and mobility in an organization ensures flexibility; however, mass and mobility are opposites and tend to pull organizations in different directions. Nathan Bedford Forrest said it best when he said, "The idea in war is to get there the firstest with the mostest." The ability to move rapidly and achieve mass is what ideal organizations should do.

The French Grand Army's ability to move rapidly and mass on the battlefield was achieved in part by its organizational structure. The organizational structure of regiments, brigades, divisions and corps were key to its success.

The French Grand Army's ability to move rapidly was based on the following characteristics. First, they organized into small units capable of independent action.

More rapid movement of armies was becoming practicable by the recent invention of the divisional system... The divisional organization, standard in France by the 1780's, provided mixed bodies of infantry and artillery, which could march in separate columns and were strong enough to fight independent actions. ⁸

Secondly, small independent units could live off the land better than large units. These organizations, "disgarding cumbersome

supply trains, were capable of more rapid movement."⁹ Thirdly, decentralization of command, due to the need for independent movement, allowed commanders to forego the cumbersome and time intensive command channels. "The division commanders were to keep in touch with each other, but were not to "waste time waiting for orders..."¹⁰ Organizational structure, the lack of a cumbersome supply system and the decentralization of command allowed the French to achieve mobility. Despite this emphasis on mobility, the French Army of the Napoleonic era also developed the ability to concentrate.

The French Army's ability to mass was based on the following characteristics. First, positioning of units prior to battle. The corps system allowed one corps to initiate and maintain contact with enemy forces. It's capability of independent action for 24-48 hours allowed the other corps, usually within a days march, "to fall upon the enemy's rear."¹¹ Positioning of forces allowed the French to achieve superiority of combat power at times of Napoleon's choosing. Secondly, the use of combined arms at the regiment, division and corps level allowed for rapid concentration of force. Each corps had several infantry divisions, themselves being combined arms organizations, plus additional cavalry, artillery and engineer units. In 1809 Napoleon issued artillery to each regiment to enhance massed fires.¹² The use of combined arms at all levels improved the ability of the French to mass. Napoleon realized that trained soldiers were the key in achieving mass and mobility on the battlefield. Good training at regimental level enhanced the

ability of divisional commanders to concentrate their forces. "Recruits were assigned to their regiments at once, trained by the veterans... and were considered properly trained after two months of campaigning."¹³

The four key ingredients for a good organization which evolved from classical military art were first, an army must have the ability to move rapidly and achieve mass. Organizing into separate self-sustaining units allowed the French Army to achieve rapid movement and mass. Second, units must have some sort of combined arms organization to be useful. Each organizational level adopted by Napoleon possessed some sort of combined arms capability. Third, sustainment must not hinder the ability of an army to move. Discarding the cumbersome supply structure and living off the land improved the French Army's mobility. This is not a viable option today, but the concept of splitting into smaller self-sustaining units is important in deciding what organization to adopt. Fourth, training must occur at the level which organizations are employed. This provides the "train as you intend to fight" philosophy.

A balance of mass, mobility, sustainability, training and combined arms must occur for an organization to maintain its flexibility. The Roman Legion and the French Grand Army were close. The U.S. Army has been looking for such an organization, which balances all these characteristics, since its decision to adopt the divisional organization in 1916.

III. U.S. ARMY TACTICAL ORGANIZATIONS

A description of each divisional organization will be covered along with an examination of each system (brigade through corps). Examination of each system will include an evaluation of where tactical flexibility was structured. Factors which caused this organization to change and what led to the adoption of a new organization will follow.

A. WORLD WAR I

The American infantry division of 1917 consisted of two brigades of infantry, one brigade of field artillery, a regiment of engineers, and the division's supply and sanitary trains. It had an authorized strength of 27,313 personnel. (Appendix A) The basic maneuver unit of the division was the brigade which consisted of two infantry regiments. Each regiment was a fixed organization consisting of three infantry battalions and a machine gun company. The authorized regimental strength was 112 officers and 3,720 men.¹⁴

The World War I infantry division was referred to as the square division because of its two brigade two regiment configuration. It "was created specifically for the fighting on the western front,"¹⁵ to enable it to sustain losses and continue its mission. It was two to three times the size of the French or British divisions which usually numbered 8,000 men or fewer.¹⁶ Mobility was replaced with mass, based on the need to

fight a war of attrition. Another 14,000 personnel were required to support it, bringing the total for each division to around 40,000.¹⁷ Other reports put this number higher once all corps, army and theater troops were counted.

The size and structure of the square division severely constrained its flexibility. The division commander did not have the organizational structure to maintain a reserve. The division employed and provided support to the brigades, and "the only reserve available to the division commander was the two-battalion combat engineer regiment, which was frequently pressed into service as infantry."¹⁸

The corps commander did not have the flexibility to move these extremely large divisions easily. The size of the division made it very unwieldy to move on a moment's notice and too large to keep in reserve. American divisions when employed in the line would occupy an entire sector previously occupied by a French corps of three divisions.¹⁹ The size and structure of the square division reduced flexibility to the division and corps commanders.

Flexibility was centered at the brigade level. The brigade commander maintained the ability to move forces rapidly and continue operations. The brigade, with its two infantry regiments of about 3,800 personnel each, was small enough for rapid movement, but large enough for offensive operations. According to Jonathan House,

The apparent intent was that an American brigade commander, with one regiment in combat and the second behind it, could

leapfrog his regiments to sustain an offensive almost indefinitely, thereby cutting the decision cycle time necessary to relieve exhausted assault troops.²⁰

The brigade also became the level where combat, combat support and combat service support units were integrated. The brigade commander retained the freedom to go anywhere on the battlefield and influence the situation. "Brigade commanders were free to command from forward locations,"²¹ and this ability to lead from the front put the brigade commander in the best position to allocate resources. Synchronization occurred at the brigade level due to the requirement to maintain and sustain momentum, the ability to see the battlefield and know where assets should be employed. Synchronizing maneuver with fire support allowed the brigades to maintain their tempo, and the divisions pushed support forward to maintain this tempo. The brigade's ability to synchronize assets and the agility inherent in its command structure made it ideal as the keystone of the U.S. divisional organization. The U.S. brigade was equal in size to an allied division.

The fixed regiment allowed the brigades to retain their flexibility. Corps did not have the luxury to move divisions but could employ brigades. Allied corps used the fixed U.S. regiments under brigade control as the basic unit of maneuver when given a U.S. division. This allowed them to employ two or three regiments under a brigade in the line and one or two under brigade control in either the second echelon or in corps reserve. This provided the corps with flexibility and the

ability to move rapidly and mass.²² The fixed regiment provided the brigade and corps commanders with flexibility on a lethal battlefield.

Changes in doctrine, materiel development and threat capabilities caused the square division to change. First, doctrinal changes in the use of combined arms, maneuver and combat support, influenced the divisional organization. In 1921 the revised version of the U.S. Field Service Regulation insisted that no one arm wins battles, and that the combined employment of all arms was essential to success.²³ Combined arms was envisioned as essential in winning future wars.

Mobility in future wars would be as important as mass was in World War I. "Tactics were based on the premise of establishing a base of fire then maneuvering... development of a small more mobile division was suggested."²⁴ A more balanced approach toward mobility and mass was important for the new division organization.

Secondly, materiel developments in tanks, artillery and small arms influenced the divisional organization. The tank between the war years sparked interest, and in 1928 and again in 1929 an ad hoc Experimental Armored Force (AEF) was organized at the Tank School in Fort Meade, Maryland. As Chief of Staff from 1930 to 1935, Douglas MacArthur advanced motorization and mechanization throughout the army.²⁵ Materiel developments in artillery improved the ability to move and provide support to the infantry at greater ranges. Fire direction centers gave the U.S. Army a new and unprecedented degree of infantry-artillery

integration.²⁶ Small arms development allowed the infantry to maintain a high rate of fire with the adoption of the M-1 semi-automatic rifle. Materiel development influenced changes to the division organization.

Third, the change in the threat's ability to maneuver and mass influenced changes in the divisional structure. "The German armored attack on France in May 1940 gave further impetus to mechanized experiments already conducted in U.S. Army maneuvers."²⁷ The threat's abilities to use combined arms and achieve speed and mass, were being noticed by the divisional designers. Changes in doctrine, materiel development and threat capabilities caused the U.S. Army to reorganize its division and regimental organizations.

B. WORLD WAR II AND THE KOREAN WAR

There were three underlying principles in designing the divisional organization prior to World War II. First, the division organization should be mobile. Second, no unit needed weapons whose range exceeded the parent unit's area of operations. Third, divisions would be type-force along function lines, while higher echelons became task-forced.²⁸ Type-force was an organization which basically was one force oriented, while task-force was a combined arms organization.

Out of this guidance, the U.S. Army designed two different divisional organizations, one for infantry and one for armor. The infantry division in June 1941 was a triangular organization

with an authorized strength of 15,245 personnel. It consisted of three fixed infantry regiments of three infantry battalions, one antitank company and a service company in each; one artillery regiment of four artillery battalions; an engineer battalion; a service support battalion; a medical battalion; and reconnaissance units at division, regiment and battalion level.²⁹ The armored division in September 1943 had an authorized strength of 10,937 personnel and consisted of three tank battalions, three armored infantry battalions, three artillery battalions, an engineer battalion, a reconnaissance battalion, divisional service support and three combat command headquarters.³⁰ (Appendix B) These two types of divisions were standardized units while the corps and field armies were tasked organized.

The corps was a command and control headquarters while the field army was both a command and control and administrative and logistical headquarters. "Leaving administrative matters largely at army level, the corps coordinated the use of combined arms on the battlefield."³¹ The units pooled at the corps and field army level were pushed down to the division level which impacted on the regimental organization. "A typical U.S. infantry division in France during 1944 normally had attached battalions of tanks, tank destroyers, antiaircraft automatic weapons, and corps engineers. In some cases the division also had attached 4.2-inch mortars, transportation, and logistical support from pools at corps and field army level."³²

The infantry regiment became a fixed combined arms

organization for the following reasons. First, the attachments to division from corps and field army were frequently made on a semi-permanent basis to facilitate the establishment of habitual relations. Furthermore, "many of these attached forces were subdivided and further attached to infantry regiments, as were the division's organic assets."³³ Second, in 1942 the infantry regiments were authorized their own battery of howitzers. Third, combat support bypassed the corps and division level and went directly to the regimental level. "The regiment often operated with tanks, engineers and perhaps additional support attached to form a regimental combat team (RCT). Thus, the RCT was a combined arms force, a small division in itself."³⁴

The armored division combat commands were also combined arms organizations, but lacked the mass for extended operations. They were highly maneuverable but often required additional infantry support with the attachment of a RCT to provide enough mass for sustained operations. Flexibility in the infantry divisions and the armored divisions was located at different levels. The RCT allowed the corps to maintain tactical flexibility, while the combat commands placed flexibility at the division level.

The RCTs, being fixed organizations which could operate as "mini divisions" allowed the corps commander to employ them as corps reserve units. The divisions could move battalions between regiments, but it was the corps which employed complete RCTs, and gained tactical flexibility. During the Leyte operation, X corps and XXIV corps both maintained a RCT as a

reserve.³⁵

Combat commands were not fixed organizations, and when employed or used by the corps as such, often lacked the combat power and sustainment for continuous operations. Tactical flexibility was maintained by the division commander who tasked and organized the combat commands as he determined the situation. "At the lower level, the combat command concept provided great tactical flexibility through decentralized control, but it also tempted corps commanders to break up the armored division and parcel it out by combat commands, a policy that further diluted the armored punch."³⁶ The corps commander also had to employ the armored division as a unit due to its logistical requirements, "logistical requirements extended directly from division to battalions."³⁷ The combat commands were tied logistically to their division base and could not be employed as a separate unit for an extended period of time. The RCT, a fixed organization, provided flexibility to the corps while the combat commands, a flexible organization, provided flexibility to the division. Thus, when the headquarters immediately subordinate to a division was fixed, it limited the division commanders flexibility, but enhanced that of the corps. Conversely, when the headquarters immediately subordinate to the division was changeable, it gave the division commander great flexibility, but limited that of the corps.

Changes to the divisional organization following WW II were minor. In 1947 the infantry division retained its regimental combat team organization with the addition of a tank company and

mortar company. The division added a tank battalion to its organization. The corps and field army organization remained unchanged. The armored division added one more tank and armored infantry battalion. In each division the artillery was upgraded but basically retained its same organization.³⁸ The RCTs saw action in Korea and provided great flexibility to corps commanders. During the battle for the Naktong River, RCTs were rapidly shifted from one division's sector to another. The use of the 9th and 23 RCTs as independent organizations to plug gaps in the line, in different divisional sectors, provided flexibility to the corps commanders.³⁹

Changes in materiel development, doctrine and threat capabilities influenced the way the U.S Army subsequently reorganized. In 1956 the U.S. no longer had a monopoly on nuclear weapons. The Soviets now possessed strategic as well as theater nuclear weapons and, "nuclear war on the ground had grown strong enough to cause fundamental changes in the organization of the infantry divisions."⁴⁰ The Soviet's ability to wage nuclear war influenced divisional reorganization.

The U.S. Army's tactical doctrine was changing. "Nuclear war was believed likely to create so chaotic a battlefield situation."⁴¹ This situation would require divisions to fight isolated, and in all directions. The need for divisions to fight on the nuclear battlefield and the tactical implications of not massing but remaining dispersed influenced organizational changes.

Finally, the U.S. Army's materiel development focused on the

development of nuclear weapons. "The Army had to pay some attention to all the latest weaponry of ground warfare, conventional as well as nuclear."⁴² The U.S. Army encouraged research into nuclear weaponry which resulted in the Honest John, Little John, Corporal and Sergeant tactical missiles along with other weapons such as the 8-inch nuclear artillery shell and the Davy Crockett, a very short range nuclear firing rocket. Materiel developments influenced changes in the reorganization of the division and regimental structure.

C. PENTOMIC DIVISION

In the late 1950's nuclear war at the tactical level was a reality, and the U.S. Army adopted a new divisional organization. "The new design was called pentomic, an awkward designation that was supposed to indicate the supersession of the triangular division by a five-sided formation for atomic war."⁴³

The pentomic infantry division strength was about 14,000 personnel. It was broken into five battle groups, each consisting of a headquarters company, initially four infantry companies (a fifth one was added in 1959) and a 4.2 inch mortar company. The division also had one tank battalion, consisting of five companies; a reconnaissance squadron; an engineer battalion with five companies; and division artillery, initially with five 105mm howitzer batteries. This fire support proved inadequate, and in 1959 the division's five batteries gave way

to five composite battalions, each consisting of a 105mm and a 155mm howitzer battery. The division had one brigade headquarters, commanded by the assistant division commander. The division trains contained all the support organizations plus the division's armored personnel carriers grouped in the division's transportation battalion. There were only enough carriers to move one battle group at a time. (Appendix C) The corps and field army organizations remained unchanged.^^

The pentomic division was an attempt to maximize mobility and minimize mass on the nuclear battlefield. The organization failed in both areas. Mobility of the battle group relied on its ability to obtain the carriers grouped at division. If a battle group did not receive these carriers, it remained foot mobile infantry. Since the division only had enough carriers to move one battle group four-fifths of the division remained foot mobile. The division failed to achieve mobility with the majority of its forces.

The battle group lacked mass and sustaining power. The battle group was larger than a battalion, but smaller than a brigade or regiment.^^ At any one time the battle group would contain five infantry companies and possibly an attached tank company, engineer company and two artillery batteries of different caliber. "The battle group was too small to have any sustaining power in either a nuclear or non-nuclear environment."^^

Combined arms were integrated at the battle group level, but the assets to achieve this integration were controlled by

division. The division retained control of the assets normally attached to a battle group. It decided which battle group received attachments of armor, engineers and the prized personnel carriers. However, it was up to the battle group commander to synchronize events on the isolated and non-linear nuclear battlefield. Synchronization of the divisional assets was a split proposition. The division commander controlled the means while the battle group commander controlled the ways. Since no single commander could achieve true combined arms operations, synchronization did not occur well at any level.

Agility was also sacrificed in the pentomic divisional organization. "The resulting single echelon between the division and the company commanders gave the division commander a span of control that included sixteen units."⁴⁷ By eliminating one single command and control echelon, the pentomic division structure left all headquarters with excessive spans of control.⁴⁸ These excessive spans of control increased the time required for decisions to be made.

Flexibility was sacrificed at all levels of command from the battle group up to the corps level. The battle group was immobile and relied on the division for movement, the division itself being four-fifths immobile, was overwhelmed by its own span of control; and the corps could not split up the division, nor could it employ the division anywhere but on a nuclear battlefield.

Changes in doctrine and threat caused the U.S. Army to re-evaluate its divisional organization. Limited wars such as

Korea began to appear more likely than a nuclear war. Doctrine was beginning to focus on the limited non-nuclear conflict and in the early 60's the U.S. Continental Army Command (USCONARC) directed the U.S. Army to prepare a concept for limited war.⁴⁹ New strategic requirements were forcing the army to relook its divisional organization.

The threat was no longer only the Soviets but also their surrogates. This new type of threat shifted the need to prepare for a non-nuclear conventional war and led to a redesign of the divisional structure.

D. REORGANIZATION OBJECTIVE ARMY DIVISION (ROAD)

The ROAD concept was the result of the U.S. Army searching for an organization which provided more flexibility than the pentomic organization. It basically returned to the combat command organization of the WW II armored division. The division consisted of three brigade headquarters, an armored cavalry squadron, an engineer battalion, an aviation battalion, and up to eleven maneuver battalions of varying types (infantry, mechanized infantry and armor), the division support command which brought all technical and supply elements into a composite unit organized along functional lines. The organic division artillery consisted of three battalions of 105mm howitzers, later upgraded to 155mm howitzers and a battalion of 8-inch howitzers. The brigades were tasked organized as the division commander deemed necessary and could control from 2 to 5,

maneuver battalions along with their associated combat and combat support assets. The logistical support went directly from the division to the battalion organizations. The battalion became the building block of the division. The battalion was the largest "fixed maneuver organization" in the division. The division was authorized around 18,000 personnel and was a permanent organization.⁵⁰ (Appendix D) The corps and field army structures remained unchanged until the early 1970's.

Task organization occurred at the brigade level where units would be placed under the operational control of, or in direct support of the brigade. As in WW II, "constantly shifting units resulted in inefficiency and poor coordination between subordinate elements that were unfamiliar with each other. As a result, battalion and brigade commanders tried to keep the same habitual association with each other unless a radical change of mission or terrain occurred."⁵¹

The division retained flexibility based on its ability to task organize brigades as the situation developed. The brigades also had the flexibility to task organize within their organization. The brigades were a command and control headquarters between the division and the maneuver battalions. If mass were required, the division could attach additional battalions to the brigade. If maneuverability were required, the division could split into brigade organizations to increase its mobility. Flexibility to the corps was severely reduced since the brigades, like the combat commands in WW II, were tied to their divisions for support. The corps either had to employ

the division as a whole unit or to specify to the division the size of the brigade it wished detached. This required the allocation of additional assets to sustain this brigade.

Synchronization occurred at the battalion level. "The battalions became task forces receiving a variety of subordinate units of different arms, allowing integration of the arms as the mission required."⁵² The battalions, being fixed organizations and the level where combat, combat support and combat service support units were brought together, synchronized combat power. "One trend since WW I has been to move the level of tactical and administrative integration constantly to a lower echelon... Under the ROAD system, it was the battalion."⁵³

Agility also remained at the battalion level. The battalion possessed the organic means to respond to unexpected events. Since the battalion was a fixed organization with organic combat, combat support and combat service support assets it could overcome the friction of war. "Agility is usually accomplished by responding with organic means to unexpected situations."⁵⁴ Brigades possessing no organic means to deal with unexpected events and being only a command and control headquarters gave up some agility. The divisions possessed their organic means but were too large to have the agility required to react quickly to unexpected events.

Many changes have occurred since the adoption of the ROAD structure, but the "fixed division, flexible brigade" concept is still part of the divisional structure. "The ROAD concept of multiple division designs, each with a large division base of

common elements, and combined arms... has not been seriously challenged in any force design effort since 1962, including Division/Corps 86 and AOE."§§

IV. CHANGES SINCE FIXED DIVISION FLEXIBLE BRIGADE CONCEPT

Since adoption of the "fixed division, flexible brigade" concept with ROAD '62, significant changes have occurred in organizational structure above the division level, doctrine, materiel development and threat capabilities.

The corps and field army organizations have undergone significant changes since 1962. "In 1973 the Army eliminated the field army and made the corps a logistical, as well as operational, headquarters."§§ Divisional assets were moved up to corps, two of which were the Chaparral air defense missile system and the 8-inch howitzers. The division base received a fourth brigade, the aviation brigade with no additional dedicated support in either fire support or service support, and the division support command reorganized into composite as well as functional units to provide better support to the maneuver brigades. These organizational changes have significantly impacted on the corps and division support and service support.

Doctrine has seen a significant change with the adoption of AirLand Battle which changed the way the U.S. Army intends to fight. It advocates a balanced concept of firepower and maneuver as the key to winning on the battlefield. The battlefield has expanded in all directions with depth vital in

both the offense and defense.

FM 100-5 Operations is a significant change from previous versions in two key areas. It describes the need for commanders at the division and corps to fight three battles (close, deep, rear)...It also describes the need for offensive-minded warfare that can stop the attacks of an aggressor army, seize the initiative and defeat the enemy force with a combination of lightning maneuver and accurate, massive combat power, thereby avoiding a purely attrition form of reactive defense.⁵⁷

The new doctrine highlights the moral qualities and skill of leaders and soldiers as being important on the non-linear and isolated battlefield. It therefore stresses the need for leaders at all levels to understand the higher commander's intent, so in the absence of orders they can continue the mission. Imperatives which were based on history and, "considered fundamentally necessary for success on the modern battlefield"⁵⁸, were embraced.

Material developments have improved the capabilities of tactical units. Improvements in technology have made the battlefield continuous and very lethal. Systems can now operate during all types of limited visibility without slowing the tempo of the battlefield. Weapon systems such as the M1A1 main battle tank (MBT) and the infantry fighting vehicle (IFV) have significantly accelerated ground tactical mobility. The ability of mechanized forces to move cross country and maintain a high volume of accurate fire while on the move improves the combat capabilities of smaller units. Fire support weapons have also

improved our ability to provide massed and responsive fires. The ranges of tube artillery have not significantly increased, but the addition of the multiple launch rocket system (MLRS) provides the capability for deep fires. Engineer, signal, aviation and air defense artillery equipment have all increased the tempo, speed and abilities of U.S. Army forces at all levels on the modern battlefield.⁵⁹ The high rate of maneuver, the ability for real-time intelligence, the ability to continue operations on a 24-hour cycle, and the capability to mass a high volume of fire with the new systems have changed the tempo of the battlefield.

The Soviets have continued to upgrade their military capabilities, especially their ground military capability.

In this decade no element of Soviet military power has undergone more profound improvement than Soviet conventional forces. Enhancement in Soviet ground force equipment such as armored vehicles, air defense weapons, and tactical missile systems have been complemented by advances in Soviet tactical aircraft and naval forces.⁶⁰

The Soviet military force is a formidable threat. New equipment such as the T-80 (MBT), BMP-2 (IFV), BMD, ASU-85 and other weapons makes it necessary for the U.S. Army to re-examine its organization. What was a sufficiently flexible organization in the early 1960's might not provide the flexibility required today.

The other threat which has grown is the third world threat. This threat also poses a danger to the U.S. "The U.S. interests

will be at stake even if the Soviet Union is not involved."⁶¹ Third world nations are increasingly obtaining lethal weapons. It is estimated that 28 nations possess the ability to produce chemical weapons, and at least 15 nations have the technology to produce nuclear weapons. "Countries hostile to the United States will almost certainly acquire more lethal weapon systems."⁶² Modern weapons are no longer reserved for superpowers. The third world threat is becoming more serious. "Low intensity conflict, however, has been the most common form of conflict for the U.S. in the post-WW II era. Such conflict in the form of insurgency, terrorism, and subversion threatens U.S. interests around the globe."⁶³ The threat's capabilities and abilities have become significantly more diverse.

With changes in the organizational structure of the corps, adoption of a new doctrine, new materiel developments and the increased capabilities of the threat (Soviet and third world) the U.S. Army should re-examine its organizational design, which dates back to 1962. The "fixed division, flexible brigade" was a good organization in 1962, but one can legitimately question whether it can meet the challenges and provide flexibility to the tactical commanders in the 1990s and beyond.

V. ANALYSIS

In the twentieth century, the echelon immediately below the division headquarters has been the focal point where combat, combat support, and combat service support assets were

integrated. In WW I the brigades integrated combat, CS and CSS assets to sustain and continue operations. In WW II the RCTs acting as "mini divisions" operated independently as a corps reserve, or as part of a division. The armored division's combat commands, although short on mass, were employed to maintain momentum during exploitation and pursuit operations, but rarely as independent units, under corps control, as the RCTs. Brigade is the only echelon to fight both engagements and battles.⁶⁴ "Corps and divisions plan, brigades execute."⁶⁵ Brigades are an important link from the corps and divisions to the maneuver battalions. When this link was removed, as it was during the pentomic divisional organization, the division and corps lost flexibility. Flexibility is achieved by having a brigade organization in the command structure. The question is what kind? Should it be fixed or flexible?

The brigade organization can not be examined in isolation, but must be examined within the corps and divisional structure. Changes made to one of these organizations influence the other two.

Two organizational systems will be examined against an established set of criteria. The first system examined will be the current organizational structure with the corps "as the central point on the AirLand battlefield"⁶⁶, the fixed division and the flexible brigade. The second system examined, which is proposed as an alternative structure, will include the corps basically as it currently exists, but with a flexible division and fixed brigade organization. The division under the

alternative system will become a command and control headquarters similar to the corps in WW II. The forward support battalions will become permanently attached to the maneuver brigades. The remaining divisional support command assets will move to corps with only enough assets remaining at division level to support the headquarters. The division artillery assets not in a direct support role will also move to corps. Each direct support 155mm howitzer battalion will become permanently attached to the brigade. The brigade will be similar to the current separate brigade organization (Appendix E). The division will retain the command, control, communication and intelligence assets required to control 2-5 maneuver brigades.

The following five criteria have been selected for analysis: synchronization, agility, sustainability, trainability and interoperability. A rating scale will be established and each system will receive a rating based on its ability to satisfy each of the referenced criteria at each level. (Appendix F) The system which provides for the optimal rating against all criteria at all levels will be the one selected. The characteristics of the entire organizational structure, from brigade to corps, will be examined, not solely the comparison of a fixed brigade vs. flexible brigade as past studies have done.

This study uses an analytical model to compare system one with system two, two results will become apparent. The first result will indicate which system provides more flexibility, and the second will identify where this flexibility exists. Using

the analysis mentioned below and a scale of 1 to 5, with 1 being a high degree of effectiveness and 5 a low degree, the system with the lowest total score provides more effectiveness. The model also allows a comparison to be made of each level (brigade, division, corps) against each criteria. The analysis first measures system one against each criterion then system two.

SYSTEM ONE: CORPS, FIXED DIVISION, FLEXIBLE BRIGADE

Synchronization is the arrangement of combat, CS, and CSS activities to develop maximum combat power at the place desired by the maneuver commander. In system one, the brigade fights as part of the division and provides the command and control necessary to employ attached and supporting units. The brigade has no organic units assigned, and its ability to synchronize activities depends on the assets it receives from division. The brigade cannot continuously plan to synchronize assets which are not permanently assigned and might be withdrawn. The division being a fixed organization maintains assets under its control at all times. The division synchronizes the use of its organic assets by task organizing the brigades. It can weight the main effort and shift additional combat, CS and CSS elements to the brigades to influence the situation. The division's ability to shift assets among the various brigades synchronizes combat, CS and CSS activities to its advantage. Corps can synchronize combat operations through the integration of their systems into

a coordinated combined arms operation. However, since the corps' primary maneuver unit is the division, synchronization is slow. These assets historically get pushed down to the brigades. The brigades are the point where synchronization is desired, but the assets to achieve synchronization are controlled by the division and corps.

Agility, "requires organizations which can act faster than the enemy."⁶⁷ They must be able to react to the unexpected. In system one the brigade maintains agility through habitual association of attached and direct support units. This allows the brigade to develop and use standing operating procedures to reduce the time required to perform a tactical operation. The III (US) Corps Maneuver Handbook stresses the need for good and understandable SOPs to maintain agility on the battlefield.⁶⁸ The brigades have no organic means to respond to unexpected situations, but can be given additional assets as required. Habitual relationship is the way brigades and divisions achieve agility and mitigate the poor command and control organization.

The division inherently maintains agility to respond rapidly to changing situations. It possess the organic assets needed to reorganize and react to unexpected events. The division commander can reorient his brigades, change task organization, commit a reserve or realign support relationships as the situation develops. However, its size reduces its agility to react to unexpected situations. The corps also maintains agility to respond rapidly to changing situations. The corps' combat, CS and CSS assets can be reoriented to provide

additional support to the committed divisions. The corps has the ability to change task organizations, commit a reserve and reorient divisions. The corps size also reduces its agility because it must employ divisions to react to situations. Fixed organizations like the division and corps have the ability to plan continually and react to unforeseen events, but are slow because of their size. The brigade's agility is dependent on the assets it receives from the division and corps, but is more mobile because of its size.

Training management is a split proposition in system one. The division has the authority and the responsibility to ensure units are technically proficient. The brigades have the responsibility to ensure their slices become tactically proficient by training these "slices" in the mission essential tasks required to support the battle focus. Corps train non-divisional units, divisions and provides missions to its subordinate units. The corps must also ensure units are technically proficient. However, corps units usually get further allocated to the maneuver brigades where the actual tactical training occurs. The corps establishes the missions while the brigade conducts the METL training required to support these missions. Brigades have a responsibility to train units but not the authority; divisions and corps have the responsibility and the authority under system one.

Sustainment in system one is focused at the division and corps level. The division is a hands-on player. It monitors the situation and can shift support activities to assist the

FSBs. The corps is also a hands-on player and through its COSCOM it can influence support to the various divisions. The FSBs are in direct support to the brigade, but work for the DISCOM commander. Sustainment is found at each level in system one which adds depth to support operations.

Interoperability in system one is focused at the division and corps levels. The corps and divisions are fixed organizations and are able to conduct independent operations. The brigade relies on the division to sustain itself, and therefore is not suited for independent operations, unless augmented.

Interoperability implies units have the ability to operate independently from their parent organization while under the command and control of an allied or sister service unit.

Divisions and corps are inherently capable of doing this, but brigades are not.

SYSTEM TWO: CORPS, FLEXIBLE DIVISION, FIXED BRIGADE

System two fixes the brigade with its organic combat, CS and CSS assets. This allows the brigade the ability to synchronize its assets independent of the division and corps. The brigade becomes a permanent combined arms team. In order to ensure destruction of the enemy all the combined arms functions must be maximized and this is done when brigades synchronize their assets.⁶⁹ The division's ability to synchronize depends on the assets it receives from corps. However, it possess the ability to plan for the integration of the battlefield operating systems

and still must be able to synchronize combat, CS and CSS assets. There is no change in the corps ability to synchronize its assets. In system two synchronization is focused at the brigade and corps level.

Agility, in system two, is focused at the brigade and corps levels. System two allows the brigade to maximize the use of its SOPs. It also has the means to react rapidly to unexpected events. The division's agility is again dependent on the assets it receives from corps. It maintains the staff element required to plan events, but does not have the units permanently assigned. The corps' agility is enhanced because it can shift smaller units (brigades) to react to unexpected situations.

Training under system two is focused toward the train as you intend to fight philosophy. The technical and tactical training is accomplished at the brigade level. The brigade has both the responsibility and the authority. The division selects the tasks as the missions are received from corps and monitors the training. The brigade receives the tasks and trains as it intends to fight. The corps provides the battle focus as in system one. In system two, training is decentralized down to the brigades who receive and train units in the mission essential tasks required to support the battle focus.

Sustainment in system two is focused almost exclusively at the brigade and corps levels. The division is no longer a hands-on player, but still monitors the situation and influences the situation by deciding on the priority of support. The corps still maintains its capability to influence the situation

through the COSCOM. The focus of the sustainment effort is to push as much support forward to the brigade support areas. System two provides the brigade commanders with unity of command.

Interoperability in system two shifts to the brigade level. The brigade, being a fixed organization, will be capable of independent operations during cross attachment or shifting to allied or sister service sectors. The division retains the ability to receive additional brigades from allied countries due to its ability to operate as a command and control headquarters. Most NATO countries have adopted the fixed brigade concept, which enhances interoperability for the division in system two. The corps still maintains its ability to conduct joint/combined tactical operations.

The following are the advantages of selecting system one. First, it does not cause turmoil, since no change is required. Second, the division artillery command provides the division the capability to mass fires. Third, it allows economy of force operations to be conducted with a two battalion brigade. Fourth, it allows the division to mass by attaching more battalions to a brigade. Fifth, depth is provided in the CSS arena with the DISCOM element.

The following are the disadvantages of selecting system one. First, synchronization is not maximized at the brigade level. Second, tactical training of units is split with responsibility, but not authority, at the brigade level. Third, agility is not enhanced at the brigade or corps level. Fourth, the division is

too large of an organization to move rapidly, and use in a joint/combined operation. Fifth, CSS assets at the division are not fully utilized because a large portion of corps support is throughput to the brigade rear areas. Sixth, divisions cannot accept additional combat forces because they are fixed organizations. Seventh, flexibility is centered at the division rather than the corps which is a holdover from the ROAD '62 concept.

The following are the disadvantages in selecting system two. First, the division loses the ability to be a hands-on player in the CSS arena. Second, the brigade's ability to train additional low density MOSs is doubtful. Third, the ability to mass artillery fires is decreased. Fourth, fixing the brigade structure does not allow the divisions to conduct economy of force operations. Fifth, the divisions lose the ability to shift battalions to react to unexpected situations.

The following are the advantages of system two. First, the corps will possess the assets to maintain a ready reserve capable of independent operations. Second, the corps can shift combat forces rapidly across boundaries. Third, the divisions will have the ability to shift boundaries quickly and to accept various brigade mixes. Fourth, the brigade will control support to its battalions. Fifth, throughput operations are enhanced with the ability to support forward. Sixth, moving brigades will provide the combat power to influence a situation. Moving a brigade can be done in a timely manner since all coordination is internal and a single brigade SOP can be used. Seventh, the

corps can conduct economy of force operations by employing brigade size elements instead of complete divisions. Eight, system two allows the corps, divisions and brigades to conduct operations with allied units, especially in NATO.

System two provides the corps and brigade with increased flexibility on the AirLand battlefield. (Annex F) It synchronizes combat, CS, and CSS assets at the level where it historically existed, the brigade. The division continues to function as a subordinate command and control element of the corps, but its capability to move rapidly and conduct joint/combined operations for the corps, is enhanced. There are some disadvantages especially for the division, but the advantages gained by the corps and brigade outweigh them. System two supports the way the U.S. Army needs to organize to win the central battle.

VI. CONCLUSIONS

The right tactical organization is the foundation on which armies build their structure. Historically, different armies have had different foundations. The Romans built upon the legion, the French built upon the corps, and the U.S. Army built upon the field army. Recently the corps has replaced the field army and has become the largest tactical organization upon which the Army intends to build its foundation. "Today's corps is the central point on the air-land battlefield where combat power is synchronized to achieve tactical advantage."⁷⁰ The corps

requires tactical flexibility to achieve this tactical advantage. It currently uses divisions as the largest fixed organization to influence the tactical situation. With the size of today's division, the ability to move this force rapidly in a timely manner is difficult. In WW I the size of the division reduced the ability of the corps to influence the tactical situation. During WW II and Korea, the RCT provided the corps commander flexibility to maintain a reserve and influence the situation by rapidly shifting these units to different sectors. The lesson learned was that tactical organizations should be mobile and have enough combat power to influence the situation. The division was too large, so the brigade was used.

The brigade has functioned as the integration point for assets from division and corps. RCTs acted as mini divisions to provide the division and corps a self sustained unit with enough combat power to influence the battlefield. The brigade has been the combined arms unit on the battlefield for three wars.

Since the adoption of the fixed division flexible brigade structure with the ROAD '62 concept significant changes have occurred in materiel development, doctrine, threat and organizational changes to the corps. Historically, when one or more of these things changes, so has the organizational structure of the U.S. Army. With these changes and the new focus of the corps, a re-examination of the current structure needs to be accomplished. The organizational system needs to be examined not just one part of it. Since whatever change is done to one will effect the other two.

With the current need for mobility and mass and for the corps to maintain its flexibility the current fixed division, flexible brigade appears not to be the right organization for the 1990's. Currently the division controls the assets and retains the tactical flexibility to move units. The corps loses its flexibility to shift units rapidly. Divisions are too large to move quickly on today's battlefield.

An alternative structure of flexible division and fixed brigade has been submitted as an organizational structure to consider. It appears to provide the corps the flexibility it needs to rapidly shift units and influence the situation. This organization synchronizes combat power at the level where it has historically been placed. It also supports the train as you fight philosophy and provides the ability of units to sustain themselves which is useful for interoperability with allied units. Agility, flexibility and the ability to synchronize combat power add to the benefits of this organizational structure. The corps can maintain a reserve or shift self contained units rapidly about the battlefield with enough mass to influence the situation. However, there are some trade-offs with the fixed brigade at the division level. The division's ability to mass fires is not as responsive nor is its ability to synchronize combat power.

This analysis suggests that when both organizational structures are examined against the criteria of flexibility, agility, trainability, sustainability, and interoperability, the flexible division, fixed brigade structure appears to be

optimal. It is time for the U.S. Army to re-examine its organizational structure. The alternative organization (flexible divisions, fixed brigades) appears to have promise. It should be examined as a viable alternative upon which to build a new foundation for the 1990s and beyond.

VII. IMPLICATIONS

This analysis is obviously not conclusive. However, it suggests strongly that history, recent changes to the battlefield, and known contemporary requirements indicate that the flexible division, fixed brigade concept has real possibilities. It deserves further testing. The Army should conduct two tests, in a real world environment, in which fog and friction can play a part in evaluating the two systems.

Test 1: Third U.S. Corps reorganize the 1st Cavalry Division into fixed brigades, while maintaining the current organizational structure for the 2nd Armored Division. The 1st Cavalry Division base moves to corps. Each division will rotate its brigades through the NTC three times. The results be examined and evaluated.

Test 2: Test interoperability during major exercises. The employment of brigade units from I and III Corps to Europe and the Pacific during annual REFORGER and TEAM SPIRIT exercises to allow the corps to use these fixed brigades as the situation develops. Reserve Component units should be used as well as active units. These brigades should operate with allied forces

as well.

The results of these tests over a period of two to three years should provide the emperical evidence to determine if the flexible division, fixed brigade concept does, in fact, have the validity that this study concludes it has.

APPENDIX A
WORLD WAR I
U.S. INFANTRY DIVISION (1918)

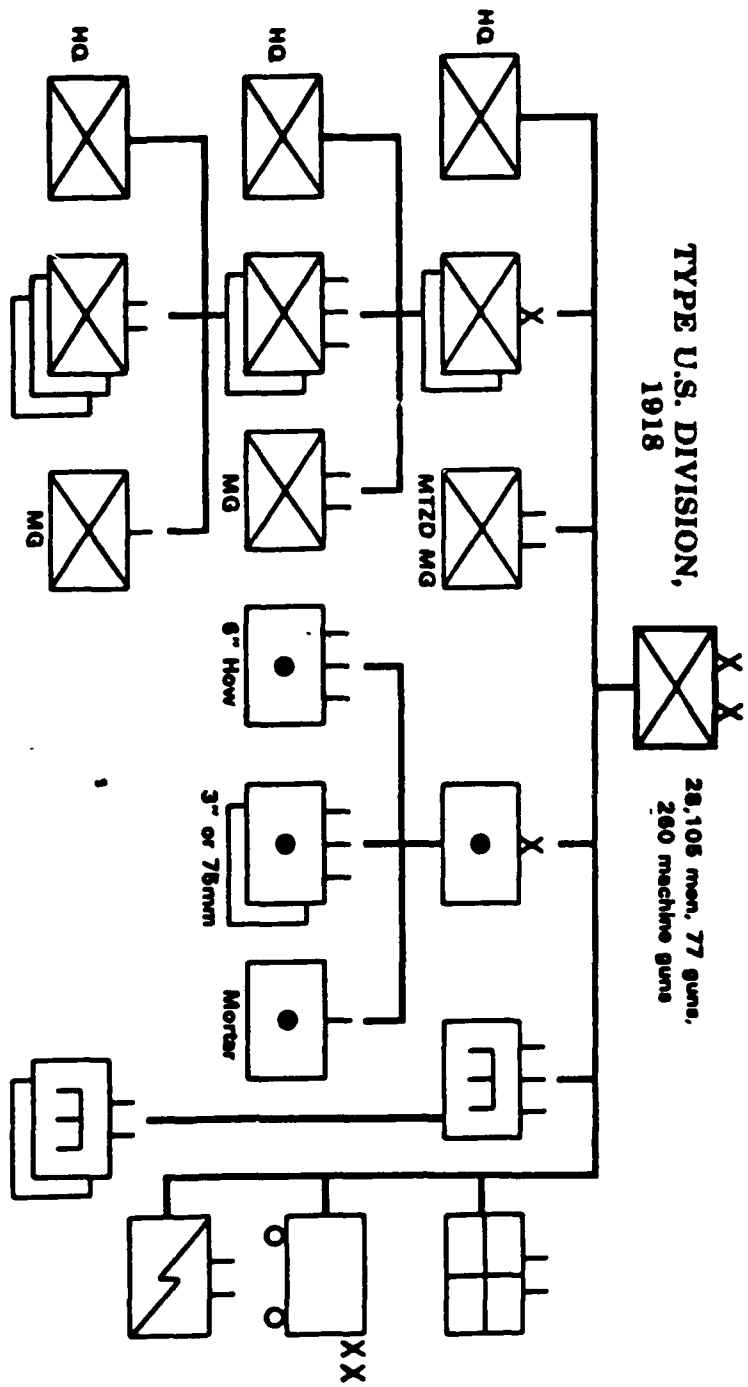

APPENDIX B

WORLD WAR II

U.S. TRIANGULAR INFANTRY DIVISION (1941)

U.S. ARMORED DIVISION (1942, 1943)

KOREAN WAR

U.S. INFANTRY DIVISION (1947)

U.S. ARMORED DIVISION (1947)

**U.S. TRIANGULAR INFANTRY DIVISION,
June 1941**

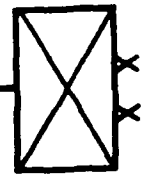

15,246 men, 48 howitzers, 68 antitank guns

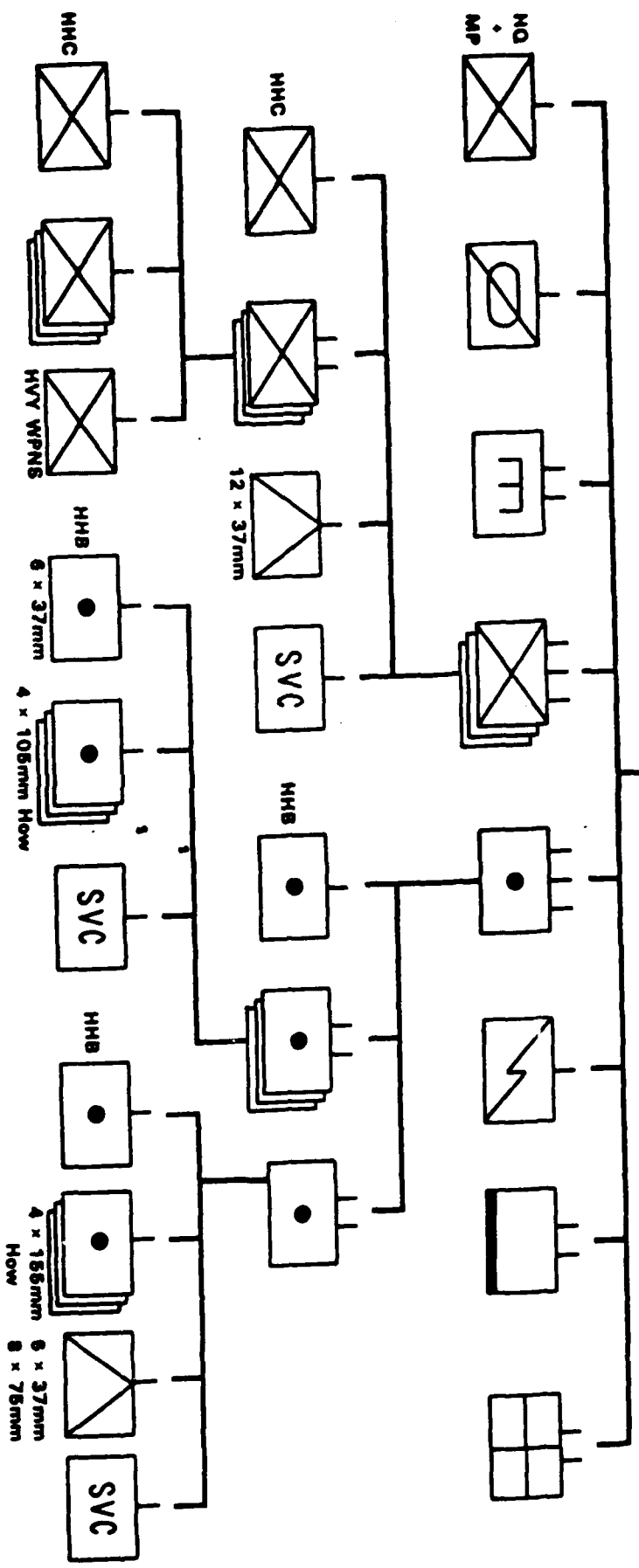

TYPE U.S. ARMORED DIVISION, MAR 1942

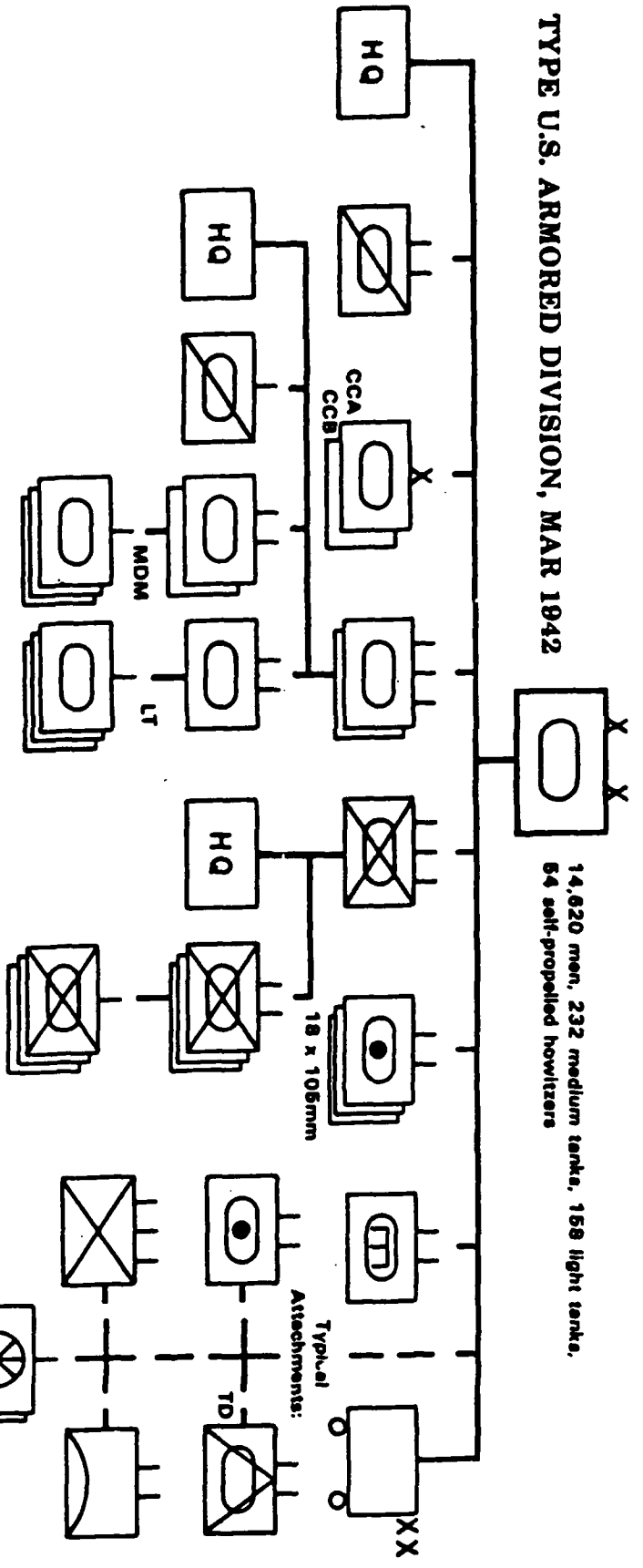

TYPE U.S. ARMORED DIVISION, SEP 1943

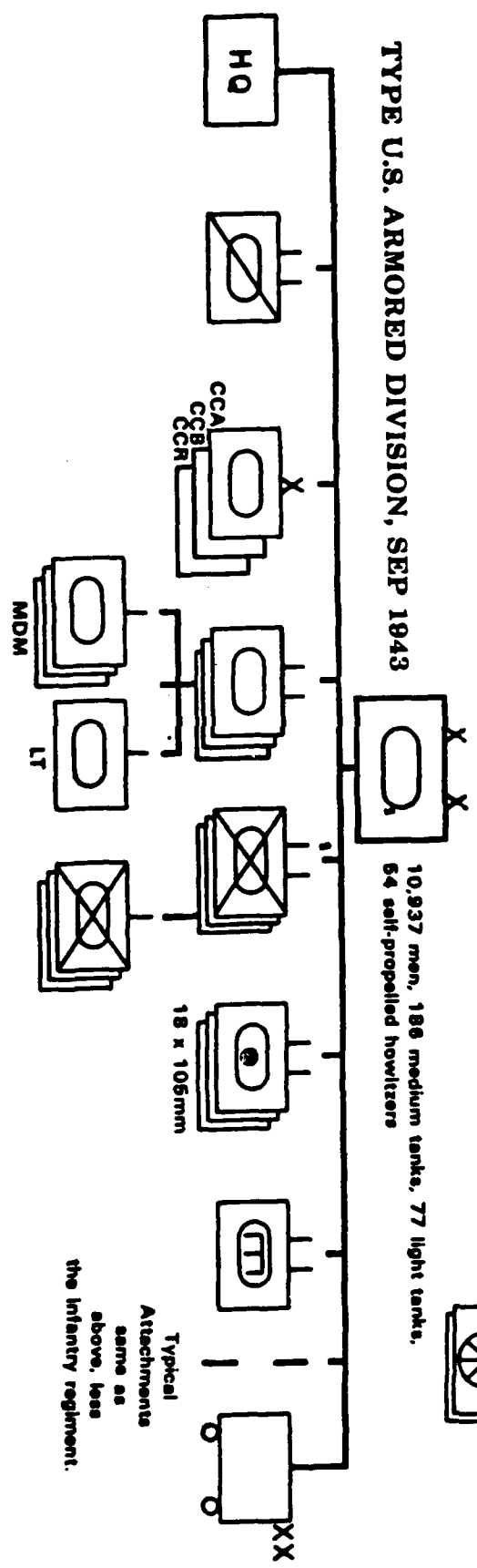

**TYPE U.S. INFANTRY
DIVISION, 1947**



17,700 men (wartime); 141 tanks;
72 howitzers

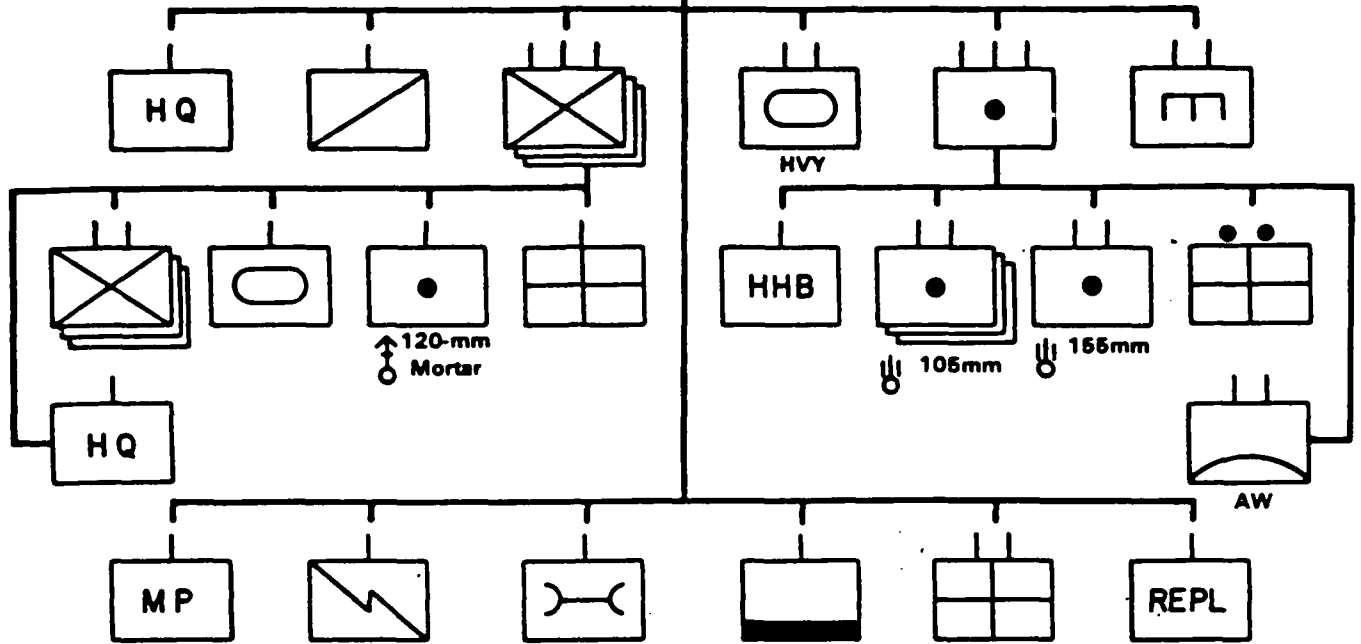

**TYPE U.S. ARMORED
DIVISION, 1947**



14,975 men (wartime); 361 tanks;
72 self-propelled howitzers

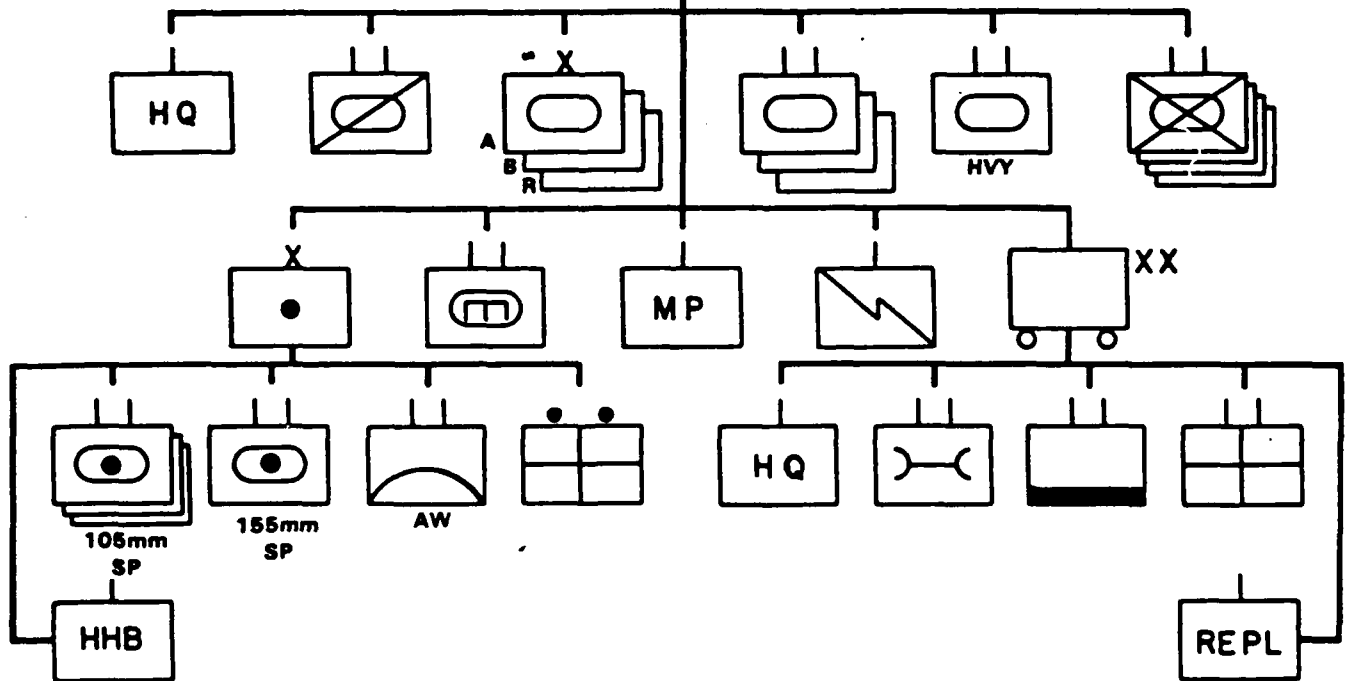

APPENDIX C
U. S. PENTOMIC INFANTRY DIVISION (1959)

U.S. PENTOMIC INFANTRY DIVISION

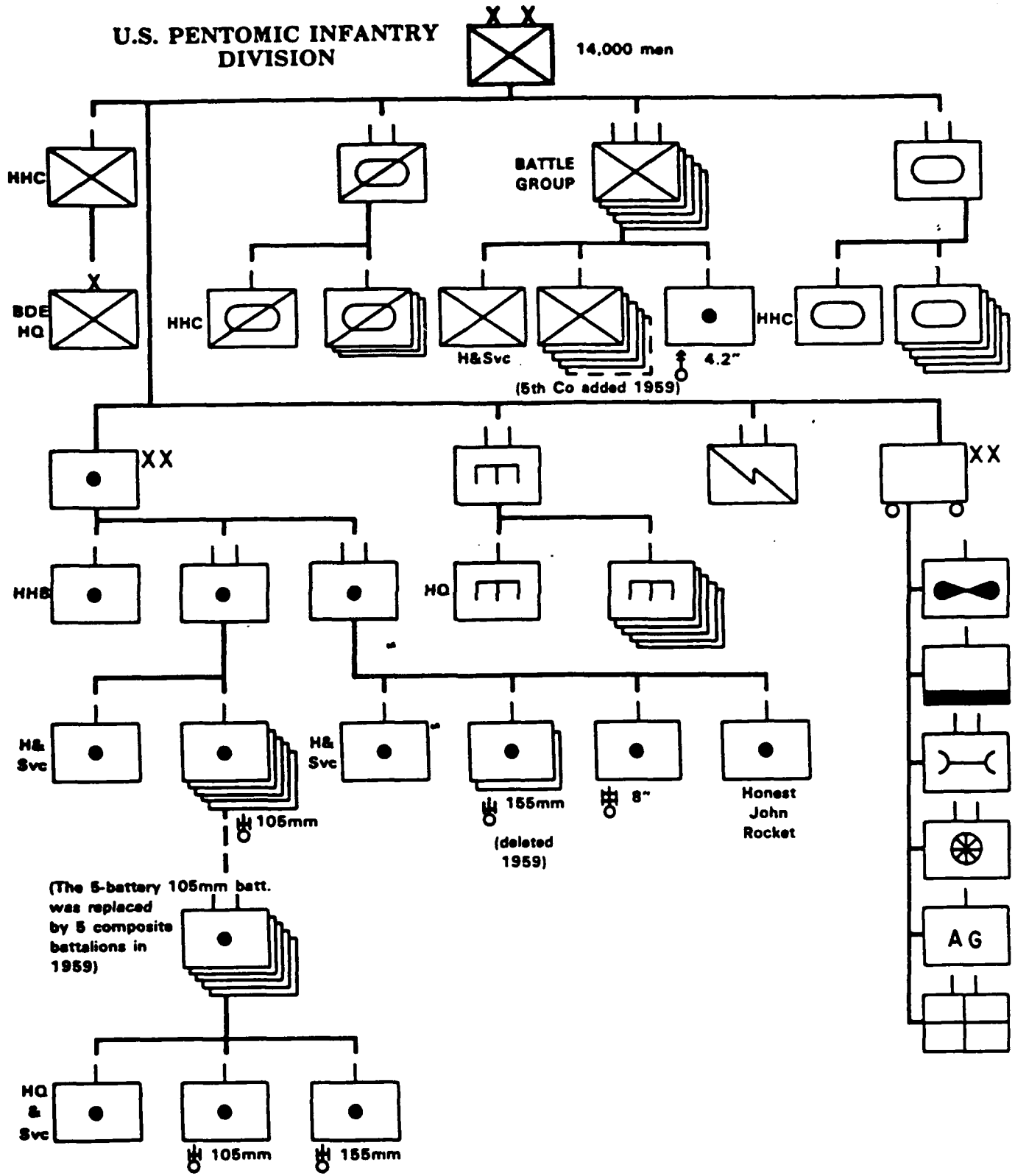

APPENDIX D
REORGANIZATION OBJECTIVE ARMY DIVISION
U.S. ARMORED DIVISION (1965)

APPENDIX E
FIXED BRIGADE DESIGN

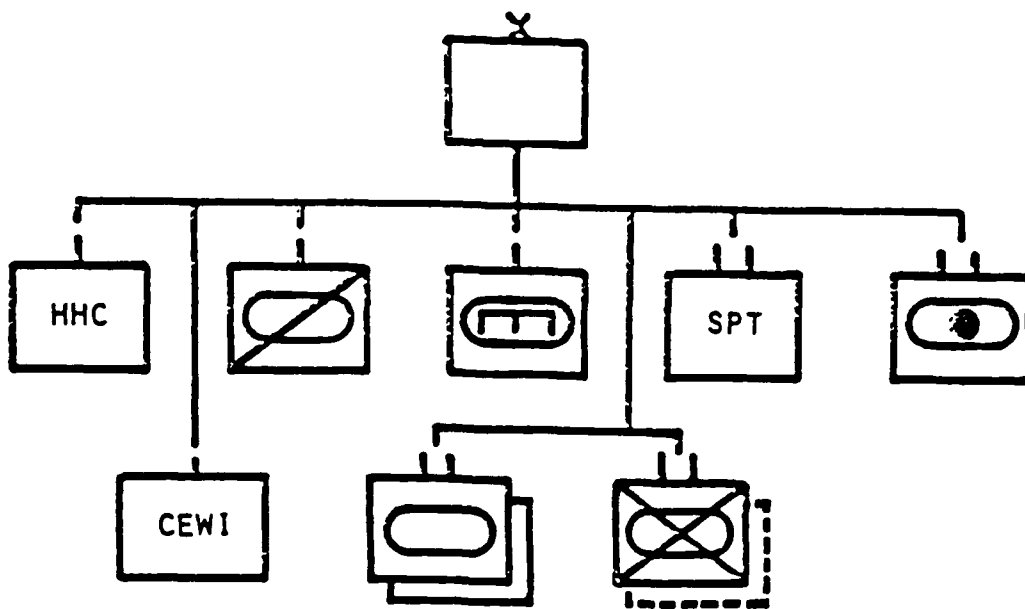

Brigade base remains unchanged in the following brigade variations. Each brigade will have recon, engineer, intel, support, and a headquarters and headquarters company plus their artillery and maneuver battalions. Signal will be part of the brigade HHC.

MECHANIZED BRIGADE

- o One 155mm How. Bri. (sp)
- o Two Mech. Inf Bn's
- o One Armor Bn.

ARMORED BRIGADE

- o One 155mm How. Bri. (sp)
- o Two Armored Bn's
- o One Mech. Inf. Bn.

INFANTRY BRIGADE (LT/ABN/AIR ASSLT)

- o One 105mm How. Bri. (Towed)
- o Three Inf. Bn's

APPENDIX F
ANALYTICAL COMPARISON

APPENDIX F

	SYSTEM 1			SYSTEM 2		
	BDE	DIV	CORPS	BDE	DIV	CORPS
SYNCHRONIZATION	4	1	3	1	3	3
AGILITY	4	2	3	1	4	2
TRAINABILITY	3	2	3	1	3	3
SUSTAINABILITY	4	1	1	2	3	1
INTEROPERABILITY	4	3	2	1	2	2
SUB-TOTAL	19	9	12	6	15	11
TOTAL		40			32	

RATING SCALE
 1 HIGH
 2
 3 MED
 4
 5 LOW

ENDNOTES

- ¹ Field Manual 100-15, Corps Operations, September 1989, p. 1-1.
- ² John C. Bahnsen and Robert C. Stack, "A Mobile Division for Future War", Military Review, June 1989, p. 28.
- ³ J. D. Hittle, "Jomini's Art of War", Roots of Strategy, (Harrisburg, PA., Stackpole Books, 1987), p. 450.
- ⁴ Ibid.
- ⁵ Carl von Clausewitz, On War, edited by Michael Howard and Peter Paret, (Princeton, NJ.: Princeton University Press, 1976), p. 294.
- ⁶ William R Richardson, TRADOC Primer, (Ft Monroe, Va.: TRADOC, 1984) p. 3.
- ⁷ Richar E. Simpkin, Race to the Swift, (London, England: Brassey's Defense Publishers, 1985), p. 123.
- ⁸ Gunther E. Rothenberg, The Art of Warfare in the Age of Napoleon, (Bloomington, Ind.: Indiana University Press, 1980), p. 23.
- ⁹ Ibid., p. 36.
- ¹⁰ Theodore Ropp, War In the Modern World, (New York, NY.: Collier MacMillian, 1962), p. 102.
- ¹¹ Hew Strachen, European Armies and the Conduct of War, (London, Eng. George Allen and Unwin, 1983), p. 44.
- ¹² Gunther E. Rothenberg, The Art of Warfare in the Age of Napoleon, (Bloomington, Ind.: Indiana University Press, 1980), p. 138.
- ¹³ Ibid.
- ¹⁴ Russell F. Weigley, History of the U.S. Army, (Bloomington, Ind.: Indiana University Press, 1984), pp.386-387.
- ¹⁵ John C. Binkley, "A History of U.S. Army Force Structuring", Military Review, Feb.1977, p. 68.
- ¹⁶ Jonathon M House, Toward Combined Arms Warfare: A Survey of 20th Century Tactics, Doctrine, and Organization, (Ft Leavenworth, KS.: U.S. Army Command and General Staff College, 1984), p.42.
- ¹⁷ Weigley, History of the U S Army. p. 386.
- ¹⁸ House, Combined Arms Warfare, p. 42.
- ¹⁹ Binkley, "A History of the U.S. Army Force Structuring", p. 42.
- ²⁰ House, Combined Arms Warfare, p. 42.
- ²¹ Ibid.
- ²² Ibid.
- ²³ Ibid., p. 71.
- ²⁴ Ibid.
- ²⁵ Ibid., p. 76.
- ²⁶ Ibid., p. 75.
- ²⁷ Ibid., p.77.
- ²⁸ House, Combined Arms Warfare, p. 75-77 and Binkley, "A History of U.S. Army Force Structuring", p. 72.
- ²⁹ Kent R. Greenfield and Robert R. Palmer, The Army Ground Forces: The Organization of Ground Combat Forces. United States Army in World War II, (Washington D.C. 1947), pp.271-274.
- ³⁰ Palmer, Greenfield, U.S. Army in WW II, pp. 276-277 and Weigley, History of the U.S. Army, p. 464.
- ³¹ Robert H. Berlin, U.S. Army World War II Corps Commanders: A Composite Biography, (Ft. Leavenworth, KS.: U.S. Army command and General Staff College), p. 1.
- ³² House, Combined Arms Warfare, p. 107.
- ³³ Ibid.
- ³⁴ Weigley, History of the U.S. Army, P. 464 and House, Combined Arms Warfare, p. 107.

- 35 M. Hamlin Cannon, The War in the Pacific, Leyte: The Return to the Philippines, (Washington D.C. 1954), pp. 64-73.
- 36 Christopher R. Gabel, The Lorraine Campaign: An Overview, September-December 1944, (Ft. Leavenworth, KS.: U.S. Army Command and General Staff College, 1985), p. 35.
- 37 Field Manual 71-100, Division Operations, 15 November 1988, p. 5.
- 38 House, Combined Arms Warfare, p. 148.
- 39 Clay Blair, The Forgotten War America in Korea 1950-1953, (New York, NY.: Anchor Books, 1987), pp. 180, 208.
- 40 Weigley, History of the U.S. Army, p. 537.
- 41 Ibid.
- 42 Ibid., p. 536.
- 43 Ibid., p. 537.
- 44 Ernest Fisher, PENTANA Study (Operations Research Office, Washington, D.C. 1965) p. 45-50 and John H. Cushman, "Pentomic Infantry Division in Combat", Military Review (Jan 1958), pp. 19-30.
- 45 Binkley, "A History of U.S. Force Structuring", p. 78.
- 46 Ibid.
- 47 Ibid.
- 48 House, Combined Arms Warfare, p. 157.
- 49 Binkley, "A History of the U.S. Force Structuring", p. 80.
- 50 Weigley, History of the U.S. Army, pp. 540-541.
- 51 House, Combined Arms Warfare, p. 160.
- 52 Ibid.
- 53 Binkley, "A History of U.S. Army Force Structuring", p. 81.
- 54 Robert W. Burkhardt, "Brigade Organization and the AirLand Battle", (Ft. Leavenworth, KS.: U.S. Army Command and General Staff College, SAMS, Dec 1985), p. 16.
- 55 John C. Bahnsen, "Kaleidoscopic U.S. Army", Armed Forces Journal International, November 1985, p. 81.
- 56 Robert C Stack and John C. Bahnsen, "A Mobile Division for Future War" Military Review, (June 1989), p. 32.
- 57 John W. Woodmansee Jr., "Blitzkrieg and the AirLand Battle", Military Review, (Aug. 1984), p. 24.
- 58 Field Manual 100-5, Operations, (May 1986), p. 24.
- 59 Peter Kock, "Guide to Army Weapons", Army Times, (23 Oct 1989), pp. D1-D-23.
- 60 Soviet Military Power: An Assessment of the Threat 1988, (Washington D.C. 1988), p. 68.
- 61 Frank C. Calucci, Annual Report to the Congress, (Washington D.C. 1990), p. 12.
- 62 Ibid., p. 13.
- 63 Ibid.
- 64 Field Manual 100-15, Corps Operations, (September 1989), p. 1-1.
- 65 Richard E. Simpkin, "Command from the Bottom", Infantry, (Mar-Apr 1985), p. 36.
- 66 Field Manual 100-15, Corps Operations, (September 1989), p. 1-1.
- 67 Field Manual 71-3, p. 1-2.
- 68 "III Corps Maneuver Handbook", Movement Handbook, (USACGSC-SAMS AY 89/90), p. 78
- 69 Army Study Project, Mounted Warfare Study 2004, (U.S. Army War College, Carlisle Barracks; PA., May 1988), p. 57.
- 70 Field Manual 100-15, p. 1-1.

Note: Appendix A thru D copied from House, Combined Arms Warfare, (Ft. Leavenworth, KS.: U.S. Army Command and Staff College)

BIBLIOGRAPHY

BOOKS

- Bellamy, Chris. The Future of Land Warfare. New York, N.Y.: St. Martins Press, 1987.
- Blair, Clay. The Forgotten War. New York, N.Y.: Doubleday Press, 1987.
- English, John A. On Infantry. New York, N.Y.: Praeger Publishers, 1984.
- Howard, Michael. War in European History. Oxford, England: Oxford University Press, 1976.
- Ropp, Theodore. War in the Modern World. New York, N.Y.: Collier MacMillan Press, 1962.
- Rothenberg, Gunther E. The Art of Warfare in the Age of Napoleon. Bloomington, Ind.: Indiana University Press, 1980.
- Simpkin, Richard E. Race to the Swift. London, England: Brassey's Defence Publishers, 1985.
- Strachen, Hew. European Armies and the Conduct of War. London, England: George Allen and Unwin Publishers, 1983.
- von Clausewitz, Carl. On War. Edited and Translated by Michael Howard and Peter Paret, Princeton, N.J.: Princeton University Press, 1976.
- Weigley, Russell F. History of the United States Army. New York, N.Y.: The MacMillan Press, 1967.

U.S. GOVERNMENT PUBLICATIONS

- Barrett, Raymond D. Jr. Coherence Between AirLand Battle and Contemporary Force Structure at Corps, Division, and Brigade Level. Ft. Leavenworth, KS.: U.S. Army Command and General Staff College, 1985.
- Berlin, Robert H. U.S. Army World War II Corps Commanders: A Composite Biography. Ft. Leavenworth, KS.: Combat Studies Institute, U.S. Army Command and General Staff

College, 1987.

Burkhardt, Robert W. Brigade Organization and the AirLand Battle. Ft. Leavenworth, KS.: U.S. Army Command and General Staff College, 2 December 1985.

Brudvig, Dale K. The Brigade With or Without Combat Support Service Support. Carlisle Barracks, PA.: U.S. Army War College, 28 May 1976.

Doughty, Robert A. The Evolution of U.S. Army Tactical Doctrine. Ft. Leavenworth, KS.: U.S. Army Command and General Staff College, August 1979.

Gabel, Christopher R. The Lorraine Campaign an Overview Sep-Dec 1944. Ft. Leavenworth, KS.: U.S. Army Command and General Staff College, February 1985.

House, Jonathan M. Toward Combined Arms Warfare: A Survey of 20th Century Tactics, Doctrine, and Organization. Ft. Leavenworth, KS.: U.S. Army Command and General Staff College, August 1984.

Harned, Glenn M. The Principles of Tactical Organization and Their Impact on Force Design in the U.S. Army. Ft. Leavenworth, KS.: U.S. Army Command and General Staff College, 2 December 1985.

Romjue, John L. From Active Defense to AirLand Battle: The Development of Army Doctrine 1973-1982. Ft. Monroe, VA.: U.S. Army Training and Doctrine Command, June 1984.

Department of Defense. Annual Report to Congress, Washington, D.C.: U.S. Government Printing Office, 1989.

Department of Defense. Soviet Military Power. Washington D.C. U.S. Government Printing Office, 1988.

U.S. Army. American Military History. Washington D.C.: U.S. Army Center for Military History, 1988.

U.S. Army. TRADOC Primer. Ft. Monroe, VA.: U.S. Army Training and Doctrine Command, April 1984.

U.S. Army. Mounted Warfare Study 2004. Carlisle Barracks, PA.: U.S. Army War College, 31 May 1988.

U.S. Army. Movement Notebook. Ft. Leavenworth, KS.: School of Advanced Military Studies, U.S. Army Command and General Staff College, AY 89/90.

Field Manual 25-100. Training the Force. Washington D.C.: Department of the Army. November 1988.

Field Manual 63-1. Combat Service Support Operations, Separate Brigade. Washington, D.C.: Department of the Army

30 September 1983.

Field Manual 63-2-2. Combat Service Support Operations Armored, Mechanized, and Motorized Divisions. Washington D.C.: Department of the Army, 29 October 1985.

Field Manual 63-3J. Combat Service Support Operations Corps. Washington D.C.: Department of the Army, 12 August 1985.

Field Manual 71-3. Armored and Mechanized Infantry Brigade. Washington, D.C.: Department of the Army, 11 May 1988.

Field Manual 71-100. Division Operations. Washington D.C.: Department of the Army, 15 November 1988.

Field Manual 100-5. Operations. Washington D.C.: Department of the Army, 5 May 1986.

Field Manual 100-15. Corps Operations. Washington D.C.: Department of the Army, 15 November 1988.

Field Circular 71-3. The Armor and Mechanized Infantry Brigade. Washington D.C.: Department of the Army, October 1985.

Field Circular 71-100. Armored and Mechanized Division and Brigade Operations. Ft. Leavenworth, KS.: U.S. Army Command and General Staff College, 7 June 1984.

PERIODICALS

Bahnsen, John C. Jr. "The Kaleidoscopic U.S. Army." Armed Forces Journal International. November 1985, pp. 78-88.

Bahnsen, John C. Jr. and Robert C. Stack. "A Mobile Division for Future War." Military Review. June 1989, pp. 26-37.

Barbara, James C. and Robert F. Brown. "Deep Thrust on the Extended Battlefield." Military Review. October 1982, pp. 22-32.

Binkley, John C. "A History of U.S. Army Force Structuring." Military Review. February 1977, pp. 67-87.

Clark, Wesley K. "The Penetration: Brigade Task Force in the Attack." Military Review. October 1988, pp. 38-48.

Depuy, William E. "Toward a Balanced Doctrine." Army. November 1984, pp. 18-25.

Durik, James M. and James J. Montano. "FM 100-5 Conceptual Models and Force Design." Military Review. July 1984, pp.

16-26.

- Holder, L.D. "Maneuver in the Deep Battle." Military Review. May 1982, pp. 54-61.
- MaHaffey, Fred K. "Structuring Force to Need." Army. October 1984, pp. 204-216.
- Simpkin, Richard E. "Command from the Bottom." Infantry. Mar-Apr. 1985, pp. 34-37.
- Starry, Donn A. "Extending the Battlefield." Military Review. March 1981, pp. 31-50.
- Stubbs, Kevin D. "A Re-Examination of U.S. Mechanized Forces." Military Review. August 1988, pp. 25-41.
- Wass de Czege, Huba and L.D. Holder. "The New FM 100-5." Military Review. July 1982, pp. 52-70.
- Woodmansee, John W. Jr. "Blitzkrieg and the AirLand Battle." Military Review. August 1984, pp. 21-39.

DOCUMENTS

- U.S. Army. "AirLand Battle Objective Force Structure." Ft. Leavenworth, KS.: U.S. Army Combined Arms Center - Combined Arms Combat Developments Activity, 1988.
- U.S. Army. "Army of Excellence." Ft. Leavenworth, KS.: U.S. Army Combined Arms Center - Combined Arms Combat Developments Activity, 1985.
- U.S. Army. "Maneuver Oriented Corps (MOC) '96." Ft. Leavenworth, KS.: U.S. Army Combined Arms Center - Combined Arms Combat Developments Activity, 1986.
- U.S. Army. "ROAD 65." Ft. Monroe, VA.: U.S. Continental Army Command, March 1961.
- U.S. Army. "Combat Development Study Directive: Army Organization for Period 1965-1970." Ft. Monroe, VA.: U.S. Continental Command, 6 February 1961.