

FILE COPY

UNLIMITED

BR 108365

DRIC-T 168

①

AD-A227 083

DRIC-T 8168



PROCUREMENT EXECUTIVE MINISTRY OF DEFENCE

DRIC TRANSLATION

DESIGN OF GLUED JOINTS, ELASTOPLASTIC ADHESIVES

Malgret
Martin
et al

SNIAS-WT-18926/AQ ET

Translated by Mrs E Godwin

November 1988

DTIC
ELECTE
OCT 01 1990
S D D
Co

DISTRIBUTION STATEMENT A
Approved for public release
Distribution unlimited

COPYRIGHT (C) CONTROLLER HMSO LONDON 1988

DEFENCE RESEARCH INFORMATION CENTRE

Kentigern House, 65 Brown Street, Glasgow, G2 8EX

UNLIMITED

90 09 28 011

D.R.E.T./ARMINES
 SUB-GROUP 3
 Design of glued joints
 Elastoplastic adhesives
 Progress report on 1st part of study

Maignret, Martin and Menrath
 Aerospatiale, Devision Systemes Balistiques et Spatiaux NT 18926

(from French)

Author's summary: this report presents the purpose and the different stages of the study as a whole. The experimental work, calculations and software for the 1st part are described. Tests to define the properties of the selected adhesive HYSOL EA 9628 NW and joint tests were carried out. Calculation methods with software programmes were developed and applied with the finite-element method. A study of the elastoplastic field was undertaken. It will be continued along with the final characterisation tests, during the second stage of the contract.

Accusé de réception	
NITIS - CRAS	<input checked="" type="checkbox"/>
DTIC TAB	<input type="checkbox"/>
Unannounced	<input type="checkbox"/>
Justification	
By _____	
Distribution /	
Availability Codes	
Dist	Avail and/or Special
A-1	

Indexing terms

- adhesives
- HYSOL EA 9628
- glued joints
- mechanical characterisation
- methods of calculation
- software

Category 2.3A.3B (2) (3) (3)

Department: AQET

Name: M Fresse

Signature

1. Object of investigation

The purpose of this study is to develop experimental methods for defining the mechanical characteristics of adhesives with elastoplastic properties and methods of calculation for analysing the behaviour of and the dimensioning factors relating to bonded joints. Tests on bonded joints, continued until adhesive failure, make it possible to validate the general model used for this study by verifying that the experimental results, gauge measurements and failure loads are practically identical with the calculated results.

The elastoplastic adhesive selected by Sup-group 3 is the adhesive HYSOL EA 9628 NW.

This study thus includes both experimental work and calculation.

- Experimental work

mechanical properties of the adhesive:

The mechanical properties stated by the suppliers are generally incomplete. Thus, in the hypotheses relating to pure shear (case of tubular assembly, for example), linear characteristics, only the tests in the ZWICK torsion meter and rupture by simple shearing (DIN or PrEN test pieces) enable us to find, rapidly, the shear modulus G and the breaking stress with pure shear.

In the general case, the following tests are necessary:

- * tensile test on 'dumb-bell' bars - measurement by gauges (✓) and by extensometer (E): $\sigma_c = f_1(\epsilon)$ $v = h(\epsilon)$

- * compression $\sigma_c = f_2(\epsilon)$
- * simple shear on D.I.N. or PrEN test joints = Althof extensometer
t = g(Y)
- * breaking test - 'slab' type test pieces
- * loading - unloading cycles (dumb-bell test pieces)
- * effect of polymerisation and temperature (different kinds of adherend)

Also, if necessary, these characteristics should be determined as a function of the temperature, ageing, humidity and various environments.

.mechanical characteristics of adherends

The properties of metals are generally known. On the other hand, it is sometimes necessary to characterise the composite materials for these have special features. Thus, in crossed fibres (45° approx) the composite material is non-linear because of the predominance of the matrix. These materials may peel off (1st layer near the joint). They have edge effects. Local deterioration may occur with a sudden decrease in rigidity.

.tests on bonded joints

In order to confirm the validity of the model used for the study we carry out tests, continued to failure, on bonded joints. In these tests, we vary the main adhesion parameters (thicknesses, overlap, nature of adherends, geometry ...). If the calculated and measured values (stretching, breaking forces) are well correlated, we consider that the model is applicable for the dimensioning of the bonded joints. This model involves several stages in which principal characteristics are considered on the basis of increasing difficulties.

-Calculation

Two types of methods were developed:

.methods peculiar to bonding. These allow rapid definition. Simplified methods give an analytical solution in the case of the linear

behaviour of the material, shear stresses alone, and simple shear (identical adherends, normal stresses and shear stresses).

The methods relating to non-linear characteristics give numerical solutions resolved by finite differences. The simplification is based in the mono-dimensional sub-division.

. The finite element method. The mesh is two-dimensional or three-dimensional (lot of calculation). The difficulty in preparation, procedure and application arises from the very fine mesh due to the very small thickness of the joint (0.08mm) and to the effects of the free edge.

The study peculiar to bonding, includes the following aspects:

- characteristic relationships in a non-linear, elastic material,
- plasticity conditions, loading - unloading - loading (cycles),
- criteria for failure.

This study is based, particularly, on the experimental work defined in the previous paragraph:

- . (pure) tensile, compression and shear tests,
- . relaxation,
- . failure under the effect of compound stresses.

An adhesive behaves differently from the classic orthotropic metallic materials. The VON MISES-HILL laws are not applicable. Some authors (ISHAI, RAGHAVA) have established special relationships.

Section 1 presents a synthesis of the objective of the study as a whole. The following paragraphs describe the experimental work and calculations with the main results obtained in the course of the study relating to this first contract.

Summary of work programme and of the distribution of functions in Sub-group 3 - First contract.

The notes AQEN No.16309 of 7/3/85 and No.17826 of 26/2/86 give the work programmes of Sub-group 3:

3.1 Experimental work

2.1.1. Bibliography - AEROSPATIALE-AQUITAINE (AQ).

- methods of defining physico-mechanical properties of adhesives.
- Principal adhesives - Known mechanical characteristics (suppliers etc...)

2.1.2. Characteristics of the adhesive.

- measurement of flow : AQ.
- adhesive alone.
 - . making the test pieces: AQ.
 - . complete characterisation in tension : AQ.
Measurements by D.M.A. (dynamic) of E modulus: AEROSPATIALE LES MUREAUX (MU).
- adhesive with adherends in simple shear
 - I.G.C. 0426101 B : AQ.
 - P.r.E.n : 2243-6 :
 - Making the test pieces : AQ.
 - Tests : AQ-MU.

2.1.3. Test pieces studied.

- . Designs and experimental plan for test pieces : AQ.
- . Making the test pieces : MU.
- . Tests : E.N.S.T.A. - AQ.

2.2 Calculations

2.2.1. Ecole des Mines se Saint-Etienne.

Development of a mixed element (stresses - displacements) of an interface and software for application.

2.2.2. AQ.

- Methods peculiar to bonding - development of software programmes.
- application of the classical finite - element method.
- Calculation for a test piece in common with Sub-group 3.
Method with finite elements and software LIC08.

The detailed calculated results relating to stresses in the adhesive and extensions in the external surface of the external adherends are presented in this note. The Ecole des Mines de St Etienne will compare them with its calculated results and the E.N.S.T.A. with its values measured by gauges (all in mm).

- non-linear calculation of a test piece (code N, except L = 7.5mm). Software programmes LICO81 (Raghava's theory) and 82 (Ishai's theory). Preliminary results.

3. Experimental work

Adhesive selected : Hysol EA 9628 NW class 120-130°C.
mass per m² : EA9628 NW (supported) : 300g/m².
 : EA9628 UNS (non supported) : 150g/m².
Polymerisation cycle : 1 h at 120°C.

3.1 Defining the properties of the adhesive

3.1.1 Measurement of flow

Its purpose is to determine the viscosity of the adhesive at the start of polymerisation and thus its characteristics as to the wettability of the adherends. We used non-supported film (EA9628 UNS) in accordance with I.G.C. 0426 101 B, method 6, and in accordance with the cycle recommended by the supplier. The tests were carried out at ambient temperatures, at the time the material was taken out of storage: 18°C, then after 15 days, to demonstrate the effect of aging. The results are practically identical, ie 80% flow.

3.1.2 Adhesive alone

Sheets of adhesive were made by stacking films into a special apparatus. After polymerisation, dumb-bell test bars NPT 5103⁴ were machined. The aging was studied. The dumb-bell test pieces were fitted with mechanical extensometers and strain gauges. They were subjected to tensile tests (to failure). Measurements obtained with gauges and with extensometers differ only slightly. Although usually less precise, the measurements by gauges are nevertheless necessary in order to measure Poisson's coefficient. The stress-deformation curve was related to the ambient temperature.

Section 2: definition of the test pieces, tests and principal results obtained.

Section 3: influence of aging of the film, at ambient temperature, before sheets are made.

Section 4: stress-deformation curve : $\sigma = f(\epsilon)$. By way of information, we include the results obtained by the Central Laboratory of AEROSPATIALE (DCQ/L). The AQ and DCQ/L results are comparable.

Section 5: extract from report of AQEN test No. 11044 of 21/5/86, obtained with mechanical extensometer on test bar 1-3.

For each of the 3 batches (without aging, with 5 days' aging and with 30 days' aging, 7 test pieces were examined ie a total of 21.

Each test piece was fitted with 2 directional gauges on each surface and with one mechanical extensometer.

Section 6: influence of aging in the polymerised adhesive.

The aging conditions are as follows: T = 60°C, relative humidity = 98%, test period = 450 hours. The dumb-bell test pieces were then given a tensile test (to failure). We compare, at different temperatures, the results of tests with and without aging (communicated by DCQ/L).

Furthermore, a torsion test on the polymerised adhesive was carried out with the ZWICK torsion meter (DCQ/L). It was found, with ambient temperature, that G = 820 MPa. It is possible to vary the test temperature.

3.1.3 Adhesive with adherends, in simple shear

- Test piece IGC 0425101 B.

This test enables us to determine, by rupture, an average shear stress in use (in the conditions for the test piece). The failure is produced by the superimposition of shearing and tensile or compression stresses. This test enables us, economically, to check the quality of an adhesive before it is used in industry. A bonded panel

Lot 5213

$$\sigma_u = 39,4 \pm 2 \text{ MPa.}$$

Tests at 80°C (DCQ/L) showed a decrease of 20%

- Test piece Pr.E.n. Test report AQEN No 11048 of 26/5/86.

This test piece corresponds with a draft European standard. The test on it makes pure shear possible, especially if the adhesive is ductile.

Section 7: definition of experimental results.

The values obtained are not too decisive for this test piece is still being studied (manufacture). However, these tests showed the effect of a rough, milled surface.

- Test piece D.I.N

This test piece, similar to the P.r.En, test piece, allows pure shear. We intended to equip it with the Althof extensometer developed by E.T.C.A with the collaboration of DCQ/L. This apparatus provides the stress-deformation more in pure shear.

Sections 8-9-10: preliminary tests (DCQ/L)

At ambient temperature $t_R = 61 \text{ MPa}$ the deformation at break is very great.

3.2 Double lap shear test pieces, type PGQ 006/04

Their purpose is to validate the experimental methods used for defining the properties of adhesives and the software for the calculations. We vary the bonding parameters.

Section 11: Definition of test pieces and how they are used.

The tests on the test joints, code N (nominal test piece) and L (length of lap) were developed at AQ. The thickness of the bonded joint, on each outer adherend was measured. Two strain gauges were placed on each external surface of each outer

adherend at $x = \frac{1}{2}$ and $x = 1$ (loaded end of the bonded length). The high cost of the gauges meant that we could not use them throughout the entire length, especially near the free end, with slight deformation, and thus more difficult to deal with. (load increase at breaking point : 2mm/mn.

The following table gives the principal results. With 3 test pieces of each type, we find very slight dispersion in the results.

length of bond (mm)	Test piece No.	dimensions of bond length x width (mm)	thickness of bond (mm)		surface area of bond (mm ²)	Failure Load (N)	average stress at break (MPa)
			face1	face2			
12.5	N1	12.49x25.1	0.083	0.067	313.5	23200	37
	N2	13.18x25.1	0.075	0.067	330.8	24300	36.9
	N3	12.71x25.05	0.083	0.067	318.4	23600	37.1
25	L1	25.44x24.99	0.075	0.075	635.7	29000	22.8
	L2	25.18x24.98	0.075	0.083	629	29500	23.4
	L3	25.31x24.98	0.075	0.075	632.2	29000	22.9

Sections 12-13-14: extract from test report AQEN No.11104 of 17/9/86.

We see that there is very good linearity in the gauge measurements, in relation to the load, up to about 80% of the break. Thereafter, the deformations increase more rapidly than the stress applied.

As the gauges are placed on the external surface of the outer adherenda, we record the effects of tension and of bending in the elastic, and then the plastic regions of the adherenda.

These effects are due to the integration of the normal and of shear stresses distributed from the bonded joint. The joint becomes plasticised in its thickness. Micro-cracks may appear. However, the gauge at $x = \frac{1}{2}$ is linear up to 80% of the break and does not show any appreciable overall loading of the joint from $x = 0$ to $x = \frac{1}{2}$.

The linear calculation is shown in § 4 (test piece code N). In the second contract, after the complete characterisation of the adhesive, a non-linear calculation (laws governing behaviour of adhesive and adherends, large displacement) will be presented in order to provide a complete interpretation of the test results.

Calculation relating to software

The adhesives behave in a special way, compared with metallic materials. We must establish the failure criterion and, in the most frequent case, notably that of HYSOL EA 9628, in the non-linear field, the law of flow (longitudinal modulus of elasticity and Poisson's coefficient) as a function of the stress and deformation conditions. An adhesive presents different curves representing stress-extension in pure tension and in pure compression. Furthermore, we must establish the law of strain hardening, loading - unloading, for even a constant increase in the external loads may cause local unloading. Finally the local degradation caused by micro-cracks may be considered. These phenomena appear systematically in the loading cycles, when the elasticity limit is exceeded.

The thickness of an adhesive is very small compared with its other dimensions and the dimensions of the adherends. Its properties may be influenced by this low thickness. The adhesion must be good, so that the bond strength of the adhesive will be greater than the cohesive strength.

The external environment may reduce the adhesive in a bonded joint i.e. the humidity, corrosion in the supports, aging etc.

Hot curing with adherends that are thermally different creates a thermal loading with a first cycle of stress.

joint. These have a free edge and thus the stresses on the external surface are nil (shear and normal along with x). In this region, the stress gradients and the stresses are high.

These various remarks show that it is necessary to characterise an adhesive completely (especially when it is very ductile (EA 9628)). Now, preliminary results obtained with pure shear tests were reported to us on completion of this first contract. Consequently, linear methods were developed and applied, and then the non-linear study was started and preliminary tests were carried out.

Note on the non-linear theories relating to adhesives

The theories of Ishai and Raghava were established on the basis of 3 tests - tensile, compression and shear. In these theories we transpose the compression and shear to the tensile characteristics alone, taking into account the isotropic component, the octohedral stress and verifying the physical measurements. At present we have no pure compression test (tubular test piece). Furthermore, a shear test on the bulk adhesive (torsion of a tube) would be desirable, because we are using bulk tension data with film shear data. We obtained $\tau_{E,R} = 49.8$ MPa, $-T_R = 61$ MPa. The film shear strain to failure is very high (Sections 8-9-10). The overall tensile strain (between reference works) is much less than the strain in the yielded part.

A supplementary investigation is therefore necessary in order to determine the reference extension at break and in order to develop the software.

Ishai's theory: $\tau_R < \frac{2\sigma_{c,R}}{\sqrt{3}} \quad \lambda_R, \sigma_{c,R} \rightarrow \infty$

or: $\tau_R < 57.5$ MPa. The adhesive Hysol EA9628 is at the limit of this theory's application.

In order to apply and compare the results of the 2 theories (Ishai's and Raghava's), we make $\tau_R = 56$ MPa (instead of 61 MPa). We calculate the compression stress at break by Raghava's theory ie:

$$\sigma_{c,R} = \frac{\tau_R^2}{\sigma_{c,R}} = 189 \text{ MPa}$$

4.1 Methods peculiar to bonding

In these methods (apart from LIC07), the loading is mechanical and/or thermal. Several successive phases may be considered. The adherends are different.

4.1.1 Hypothesis of only shear stresses in adhesives

These software calculations can be applied to tubular bonds for the circumferential rigidity prevents deformation perpendicular to the joint, the normal stresses being very slight. There are also special cases (outer adherends of negligible rigidity in double shear).

- a. Constant thickness
 - linear behaviour of materials.
analytical solution. LIC01 very rapid procedure.
 - non-linear behaviour of adhesive.
solution by finite differences: method by recurrence.
LIC02 - rapid procedure.
- b. Variable thickness of substrata - non-linear behaviour of materials. Solution by finite differences.
 - without defect. LIC03.
 - local fracture - test pieces S.I.N or P.R.E.n LIC04.
 - with defects. LIC06.

4.1.2 Hypothesis of normal stresses and shear stresses in adhesive

- a. Double-joint bonding. Elasto-plastic behaviour of adhesive.
Laws of flow and cold-hardening. Failure criterion.
Simplified case - LIC08.
Preliminary studies.
 - Reghava's theory - LIC081.
 - Ishai's theory - LIC082.
- b. Single-joint bond.
 - Identical adherends - linear behaviour of material - large bending displacement - mechanical loading alone - LIC07.

- general case - preliminary theoretical study.

4.1 Application of the finite element method (classic elements)
- linear calculation - application of test, code N (software SAMCEF)

This method is very general for we can apply it to all types of bonding and structures. We thus find 3 types of structures and 2 types of calculation:

- two-dimensional calculations:
 - . plane calculations - hypotheses of plane condition of deformation and plane condition of stresses.
 - . axisymmetrical calculations.
- three-dimensional calculations without special conditions, along the 3rd direction.

The finite-element method enables us to model the adjacent zones in a single calculation or, with a 2nd successive calculation, examine the bonded zone in fine detail.

The non-linear option available at present takes account of large displacements and involves the laws governing the behaviour of classic materials (the Von Mises criterion) or orthotropic composite materials with possible deterioration. On the other hand, the behaviour peculiar to an adhesive (Ishai, Raghava etc criteria) are not at present available for the formulation and data depend essentially on the characterisation tests.

The loads applied are static, dynamic, thermal. Modelling is very precise in the zones showing stress gradients and great stress (ends of bond). In the plasticity option, these zones are geometrically extended and detailed modelling is more important. Also, the free edges of the bonds create singularities which must be limited by the modelling.

In this first contract, a linear calculation was carried out. For that, a test piece common to Sub-group 3 was developed with its geometrical and physical data, in order to compare the results calculated with the software of the finite-element

Also, the common test piece is the test piece for studying the effects of double shearing (code N). Thus the theoretical results compared with each other, are likewise compared with the experimental measurements obtained with gauges (in the linear zone).

4.2.1. Definition of the common test piece.

Note AEROSPATIALE S/DT/S2 n° 19042 of 13/10/86

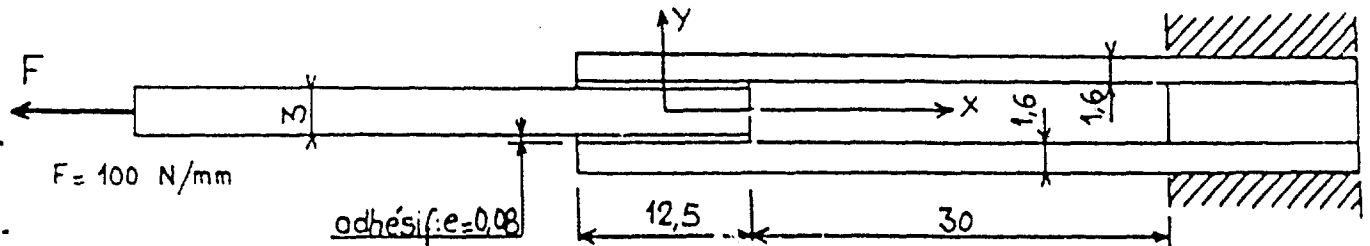

Width of test piece : 25mm

Adherends: A-U4G1 plate, A5 condition T3 $E = 72500 \text{ MPa}$

$\nu = 0.3$

Adhesive : Hysol EA 9628 NW $E = 2000 \text{ MPa}$ $\nu = 0.4$.

4.2.2. Modelling - conditions at limits.

Axisymmetrical, isoparametrical toric volume elements.

Plane deformation. Triangular section : no.26 - quadrangular

section : no.15.

Degree of the 2 fields of displacement : 2

Number of elements : 1371

Number of degrees of freedom : 8435

Number of nodes : 1464 Number of interfaces : 2834

For reasons of symmetry, half of the sample is represented and the data are produced on $\frac{1}{4}$ of the test piece.

The conditions at the limits are as follows:

- no displacements, along y, nodes and interfaces along x axis.

- impaction of ends with application of force: $F = 50 \text{ N/mm}$
(total force: 100 N/mm)

plate 15: modelisation - conditions at limits

plate 16: precise modelisation at ends of bond - mechanical data.

computer : IBM 3081 duration CPU : 4 mn 37s

4.2.3 Results

a. numerical

From the print-out the following values for the bonded joint are shown, at the surface of the central adherend, at the surface of the outer adherend and at the mid-plane of the adhesive:

x, n^e (element), $\sigma_x, \sigma_y, \sigma_z, \tau_{xy}$

plate 17: $-6.25 \text{ mm} < x < 0$

plate 18: $0 < x < 6.25 \text{ mm}$

b. graphs - stresses in the bonded joint - variation along the x-axis.

plate 19: σ_y

plate 20: τ_{xy}

c. Colour-variation of results in cross-section of joint.

results	photographs
models	1, 2, 3, 4
displacement: x, y	5
stresses: $\sigma_x, \sigma_y, \tau_{xy}, \sigma_z$	
joint	6, 7
adhesive alone	8, 9

4.3 Application of the method peculiar to bonding - common test piece.

Linear calculations - LIC081 software.

With this software, the preparation of the data and analysis of the numerical and graphical results are very rapid. The length of time

depends on the computer. With HP 85, the number of points is limited (17) and the period required for one step is 20 mn.

Plate 21 : Data and results (units : mm, N).

$k = n^{\circ}$ of point. x : abscissa of point. Y : shear stress (plane of bonded joint).

Z : tensile stress (+) or compressive stress (-), perpendicular to the plane of the joint. 1 : equivalent tensile stress (LIC081 : Raghava's criterion ; LIC082 : Ishai's criterion). 5 : safety coefficient.

It is evident that this is in good agreement with the finite-element method.

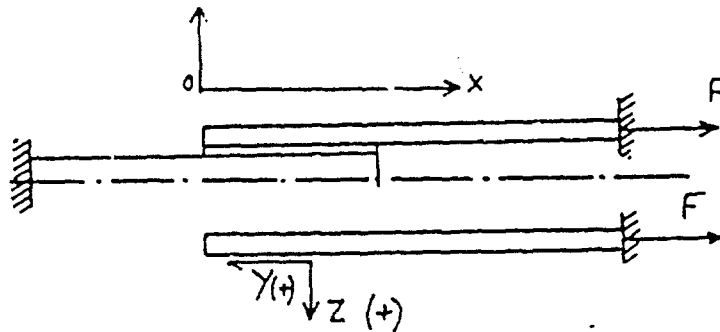

4.4. Comparison of theoretical and experimental results (linear zone, close to origin)

The test pieces subjected to double shearing were fitted with strain gauges (direction x) on the exterior surfaces of the outer adherends. The AQ test pieces had 4 gauges at $x = 0$ and at the abscissa of the free end of the central adherend. The E.N.S.T.A. test pieces had 30 gauges distributed between $x = -5.89$ mm and $x = 10.65$ mm (code C or N). E.N.S.T.A. asked to be informed of the theoretical values of the relative extension in order to compare these with its experimental findings (note ENSTA/LME/GCC no 6950 of 14/11/86) The theoretical values are calculated in the middle of each element and particularly at $x = 0$ and $x = 6.25$ mm, in order to compare them with the experimental results.

Plate 22 : theoretical relative extensions - numerical values.

$-6.25 < x < 6.25$ mm (bonded zone) $F_t = 100$ N/mm

Special interpolated values :

$x = 0$: $\epsilon_x = 0.02019$ % $x = 6.25$ mm : $\epsilon_x = 0.03843$ %

Plate 23 ; variation along x.

We compare the theoretical and experimental results obtained by AQ, in plates 12, 13, 14. Along with the recorded test results (code N1-N2-N3) we have drawn (graph) the theoretical relative extension (linear with the load). There is good agreement with the test pieces N1. With the test pieces N2 and N3, the difference with regard to gauges 7 and 9 ($x = 0$) is slight and the difference relating to gauges 8 and 10 ($x = 6.25$), although slight, is more marked.

In order to analyse those slight differences, in particular the differences between the test pieces themselves, a detailed examination would be necessary. Measurement of E and ν of supports, thicknesses etc ...

The following table shows the relative extension ϵ_x for 6.25 x 12mm (request from ENSTA). As the ϵ_x variation is slight, the representative curve has not been plotted.

X (mm)	6,2625	6,2875	6,3125	6,3375	6,3875	6,4625	6,675	7,125	7,8	8,8	10,2	12
	979	1029	1079	1129	1179	1229	1279	1329	1379	1429	1479	1529
	30,59	30,52	30,46	30,40	30,29	30,12	29,76	29,35	29,29	29,40	29,55	29,75
(MPa)	9,178	9,159	9,141	9,123	9,089	9,041	8,93	8,808	8,786	8,82	8,866	8,925
	3,867	3,830	3,823	3,815	3,801	3,78	3,735	3,683	3,676	3,69	3,709	3,734

4.5 Method peculiar to bonding - example of non-linear calculation.

LIC081 - 82 software.

In order, in this first contract, to tackle the non-linear field, a preliminary investigation of the software was carried out. The law of flow and the failure criterion were defined in accordance with the theories of Raghava (LIC081) and Ishai (LIC082). The destressing is considered to be linear with the tangent modulus in the origin. We made $\sigma_{c,R} = 49.8 \text{ MPa}$ $\sigma_{c,R} = 189 \text{ MPa}$. This value

$\sigma_{c,R}$ appears low (unfavourable hypothesis) but the tests have not yet been carried out.

The theoretical test piece conforms to the common test piece (code N) except for the length of the joint $L = 7.5$ mm (instead of 12.5 mm) for the number of points is limited.

Plate 24 : Deformation records, tensile stress, Poisson's coefficient (PO : LIC081) and σ_d/σ_c (P1 : LIC082)

Plate 25 : LIC081

Plates 26-27 : LIC082

We observe plastification towards the end $x = 0$ for the shear stress is not so great (σ of tension) as it is in the case of $x = 7.5$ mm (σ of compression). A fuller investigation should reveal greater plastification and a higher work to failure (extension at breaking point and $\sigma_{c,R}$ both greater).

5. CONCLUSION

This first contract has enabled us to increase our knowledge of the behaviour of adhesives and bonded joints. The great diversity in the characteristics of adhesives enables us to use them in the most effective way in accordance with specifications. This study, on the subject of elasto-plasticity, with the adhesive HYSOL EA 9628 NW is the most extensive for it involves non-linear calculations.

The experimental methods used for defining mechanical factors have been established and a large number of tests have been carried out. The effects of aging have been demonstrated. The variation in the experimental results is slight.

Software programmes peculiar to bonding with their hypotheses, have been developed and then applied with the finite-element method (linear calculations). In the linear field, we found that there was good agreement between the theoretical and experimental results.

In the second investigation, the definition will be completed (Althof extensometer, relaxation, failure criteria) tests will be carried out on bonded (adhesive) joints with adherends of composite material and with variable thicknesses.

The software will be developed in the non-linear field with the complete data for defining the properties. The calculations relating to application will make it possible to compare the theoretical and experimental values as regards rupture.

We shall thus have experimental means at our disposal (in agreement with DCQ/L) and also theoretical means, in order to define and study all types of adhesives, adherends and joints, subjected to all the usual stresses (mechanical, thermal, cyclic, aging etc ...)

Objective : development of experimental methods for defining the mechanical features of adhesives (elasto-plastic properties) and for determining methods of calculation for the analysis of the behaviour and for the dimensioning of bonded joints.

Adhesive tests for mechanical characterisation at ambient temperature - mechanical stress only

pure traction dumbbell test piece NFT51034 extensometer (mechanical) and by gauges

pure shearing DIN test piece and p.r.E.n. Althof extensometer

pure compression bars, tubular test pieces

relaxation test piece traction dumbbell

break test test piece of slab type

composite adherends tests for mechanical characterisation

adhesive tests for mechanical properties as a function of the temperature

- mechanical stress at a given temperature
- thermal stress - adherends of different types
- polymerisation

tests on bonded joints > validation of software

double shearing variation of parameters

thickness (adhesive, adherends), length of bond

nature of adherends (composite materials)

variation of thickness along the abscissa of joint

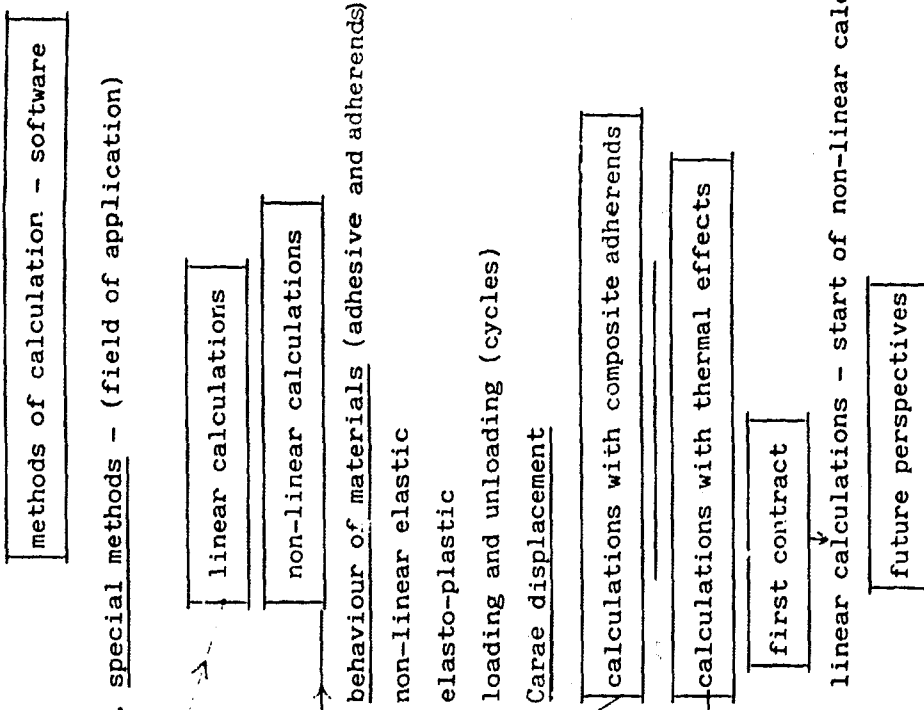

special methods - (field of application)

methods of calculation - software

linear calculations

non-linear calculations

behaviour of materials (adhesive and adherends)

non-linear elastic

elasto-plastic

loading and unloading (cycles)

Carae displacement

calculations with composite adherends

calculations with thermal effects

first contract

linear calculations - start of non-linear calculations

future perspectives

complete characterisation of adhesive - law of flow - criterion for failure

non-linear calculations - composite adherends

EA9628

traction on dumbbell test piece NPT 51034

PL 2

section : 10.2 x 3.2 (mm) nature of film : with support (NW) 300 g/m²

ref.	condition	test piece
1	film taken from stock (-18°C), then plate made	7
3	film kept for 15 days at T _a , then plate made	7
4	film kept for 30 days at T _a , then plate made	7

machine : Instron 1125 (cell 2000 N). Crosshead speed : 2 mm/mn
increased until break occurs extensometer (base 25 mm) T = 20°C
 gauge 2D (on each surface)

ref.	1	3	4	
σ_R (MPa)	50.5	49.6	48.8	
E.T. (%)	3.2	1.5	1.1	
extensometer	E _o (MPa)	2140	2120	1910
	$\Delta L/L_R$ (%)	5.25	6	7.5
gauge	E _o (MPa)	2270	2260	2325
	γ_o	0.43	0.43	0.45

ageing before curing

film HYSOL EA9628 NW (avec support) vieillissement avant polymérisation

PL 3

on test piece (dumb-bell) NFT E1034
traction sur éprouvette holtère NFT 51034

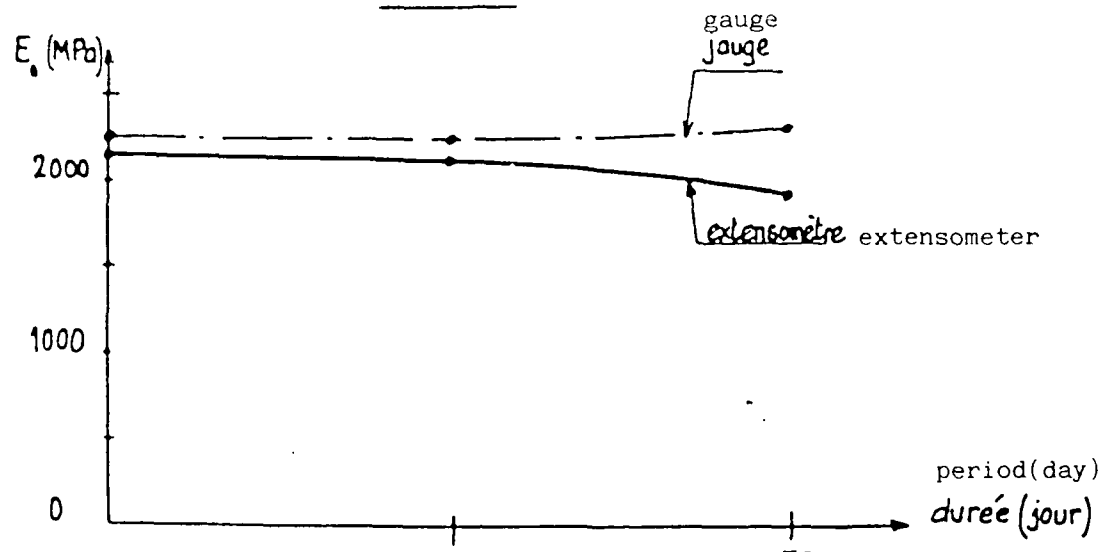

tensile modulus (at origin)
module de traction (à l'origine)

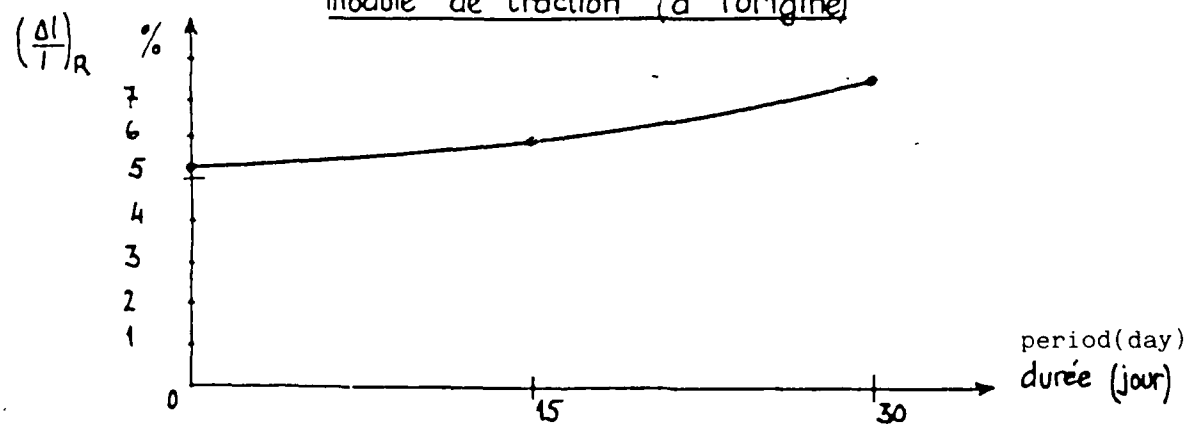

allongement de traction à rupture (extensometre)
tensile strain at failure extensometer

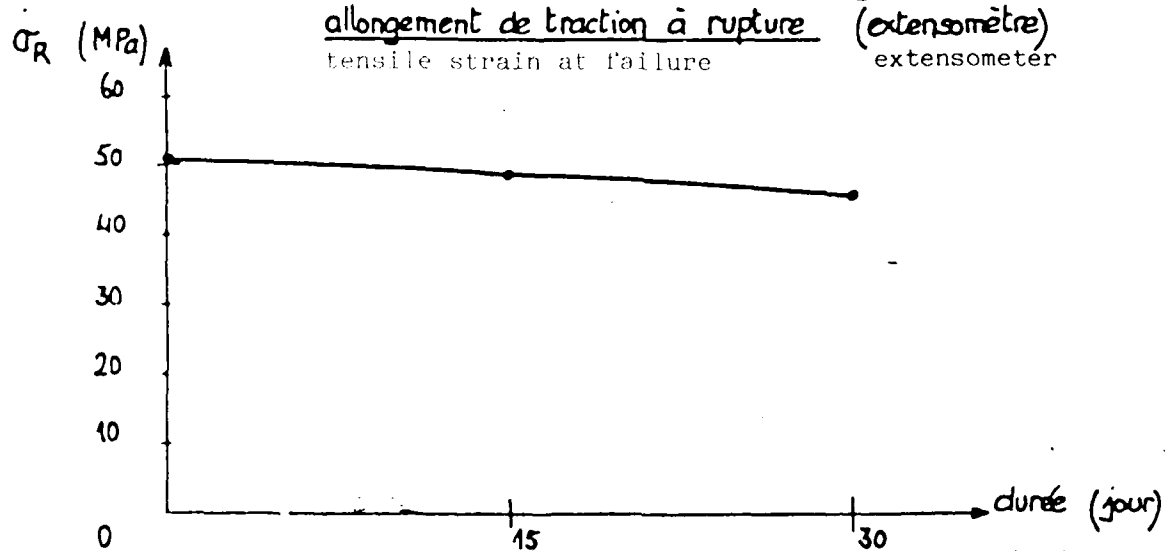

contrainte de traction à rupture
tensile strength

caractérisation AQ/EN
characterisation AQ/EN

EA9628

essai en dumbbell test piece
traction sur éprouvettes haltères

PL 4

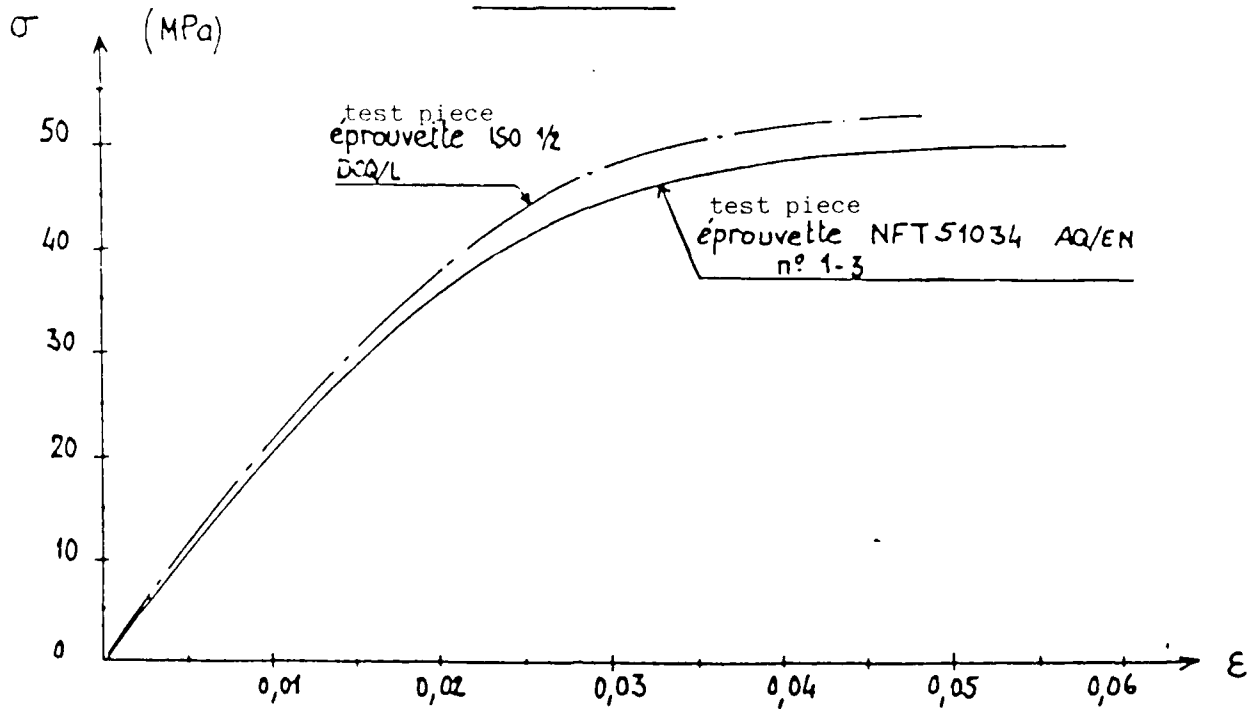

état initial
original
condition

contrainte de traction - allongement
tensile stress - strain

T = 20°C

ϵ	σ (MPa)
0	0
0,00411	9,23
0,00609	13
0,00819	17
0,0101	20,7
0,0123	24,3
0,0160	30,7
0,0201	36

ϵ	σ (MPa)
0,0241	40,5
0,0281	43,7
0,0321	46,1
0,0360	47,8
0,0400	48,6
0,0440	49,3
0,0479	49,6
0,0572	49,8

mesures expérimentales
experimental measures

A28

AGEN LAB.
LABORATOIRE AGEN
TENSILE TEST
ESSAI EN TRACTION

No DT : 86/311
EPROUVETTE No 1-3
TEST PIECE

stress
CONTRAINTE MPa

breaking point
Pt de rupture

mean $\sigma_m = 2200$ MPa
Conc: max: stress = 46.8 MPa

PL 5

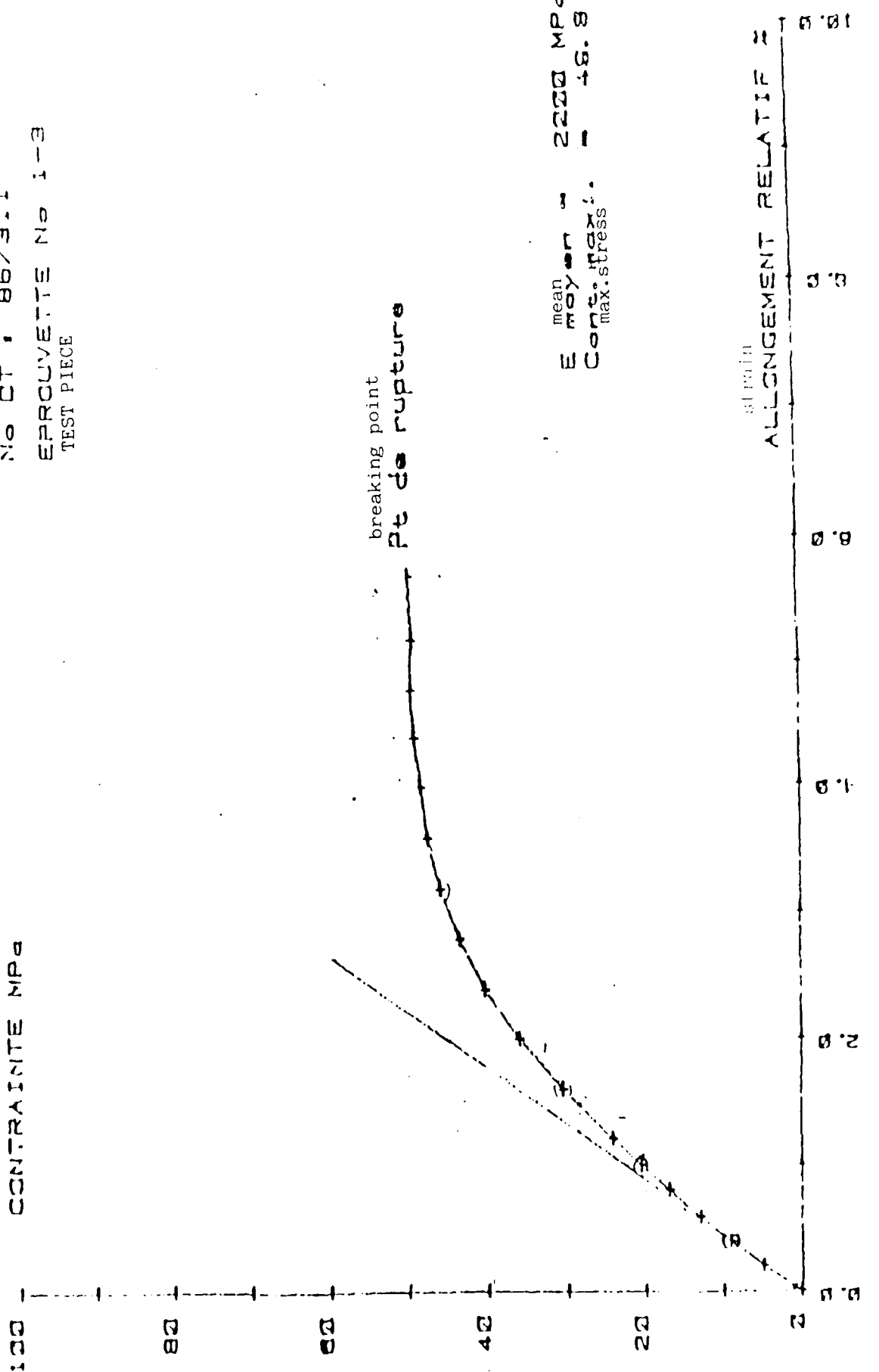

comparison EA 9628 original/aged

COMPARAISON EA9628 INITIAL/VEILLI
f (TEMPERATURE)

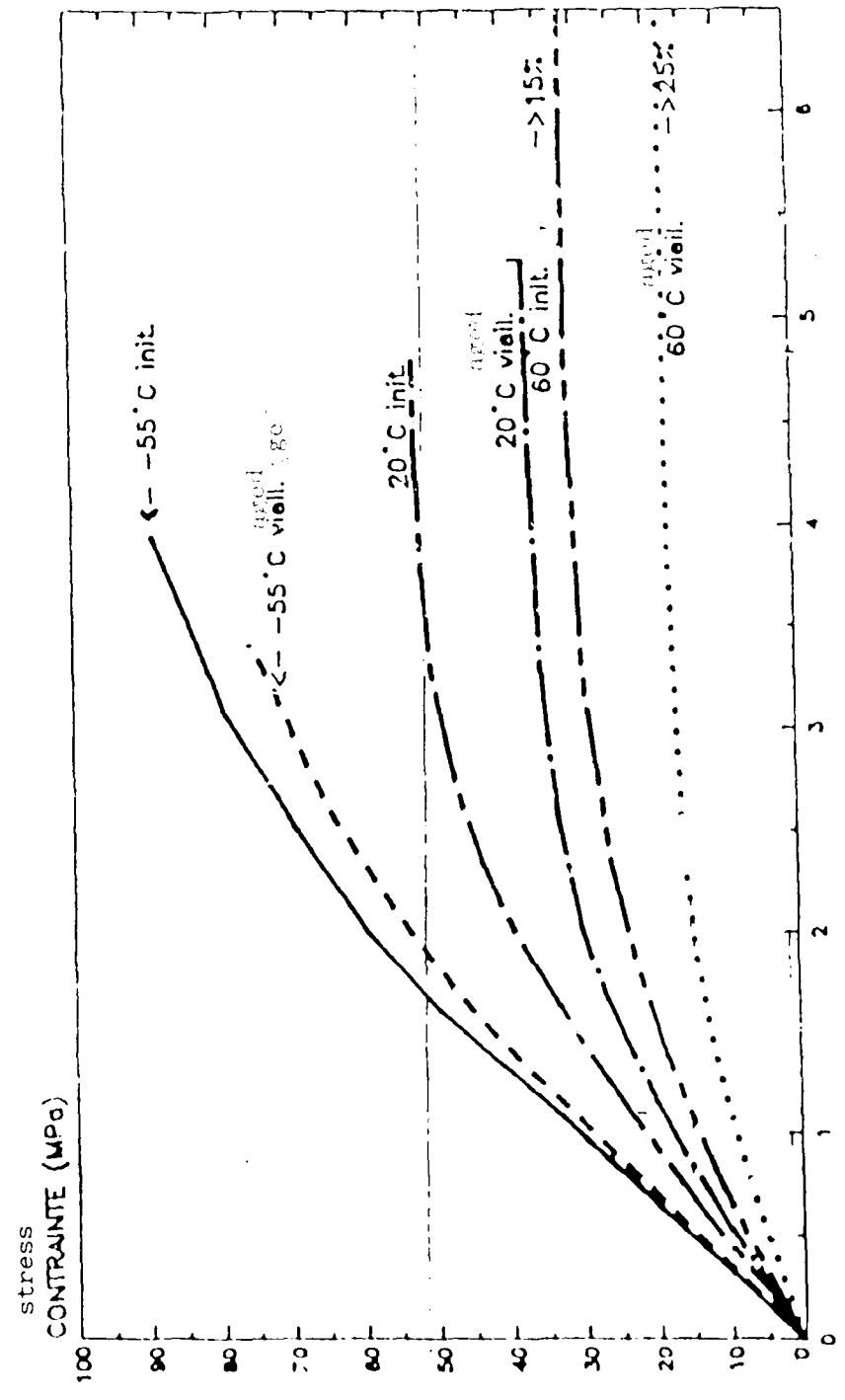

ALLONGEMENTS (%)
ELONGATION

pure shear using P.N. test joint
 cisaillement pur sur éprouvette PREN

PL 7

collage particulier de chaque éprouvette - pression : 3 bars

MU/TX et AQ/EN

AQ/EN machine : Mayes load cell cellule 5000 N

extensomètre optique

optical extensometer

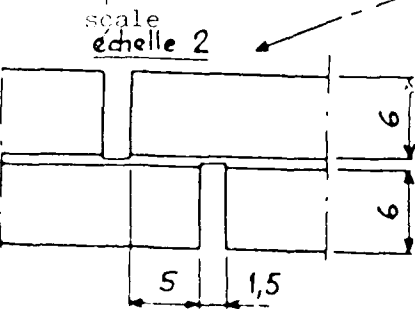
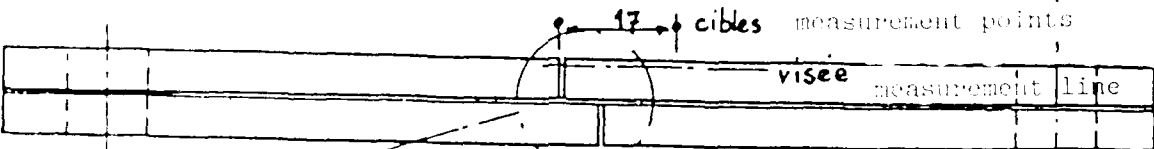
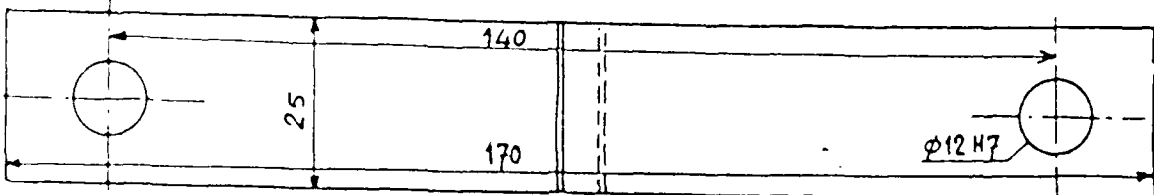

inspection
 contrôle
 thickness of film
 épaisseur du film : AQ/EN = 0,05 (mm)
 surface condition roughly milled
 état de surface : brut de fraisage

principal experimental results
 principaux résultats expérimentaux. T=20°C
 original condition (values estimated low)
 état initial (valeurs estimées faibles)

problems set
 problèmes posés

repère		F _R (N)	τ _R (MPa)
AQ	1	1.100	32,8
	2	4400	35,2
	3	4300	34,4
MU		5050	40,4
		à 5800	à 46,4

- manufacture of test pieces plate bonded
- fabrication des éprouvettes plaque collée then cut (standard) separate test pieces puis découpée (norme) - éprouvettes isolées. pressure applied at polymerisation
 - pression appliquée à la polymérisation.
 - épaisseur du film après polymérisation. thickness of film after polymerisation
 - état de surface. surface condition
 - montage d'essai. lay-out for test

(certain parameters are interrelated)
 certains paramètres sont reliés entre eux)

A28

eprouvette - test piece
recouvrement - overlap
largeur - width
épaisseur - thickness of adhesive

Adhésif EA 9628

n° éprouvette 13.1
recouvrement 5 mm
largeur 25 mm
épaisseur 0,05

\bar{L} daN/mm²

80
70
60
50
40
30
20
10

25 μ

01 02 03 04 05
lg

PL8

Adhésif EA 9628

n° épreuve	13.1
recouvrement	5mm
largeur	25mm
épaisseur	0,05

 $\bar{\sigma}$ daN/mm²

80

70

60

50

40

30

20

10

01

02

03

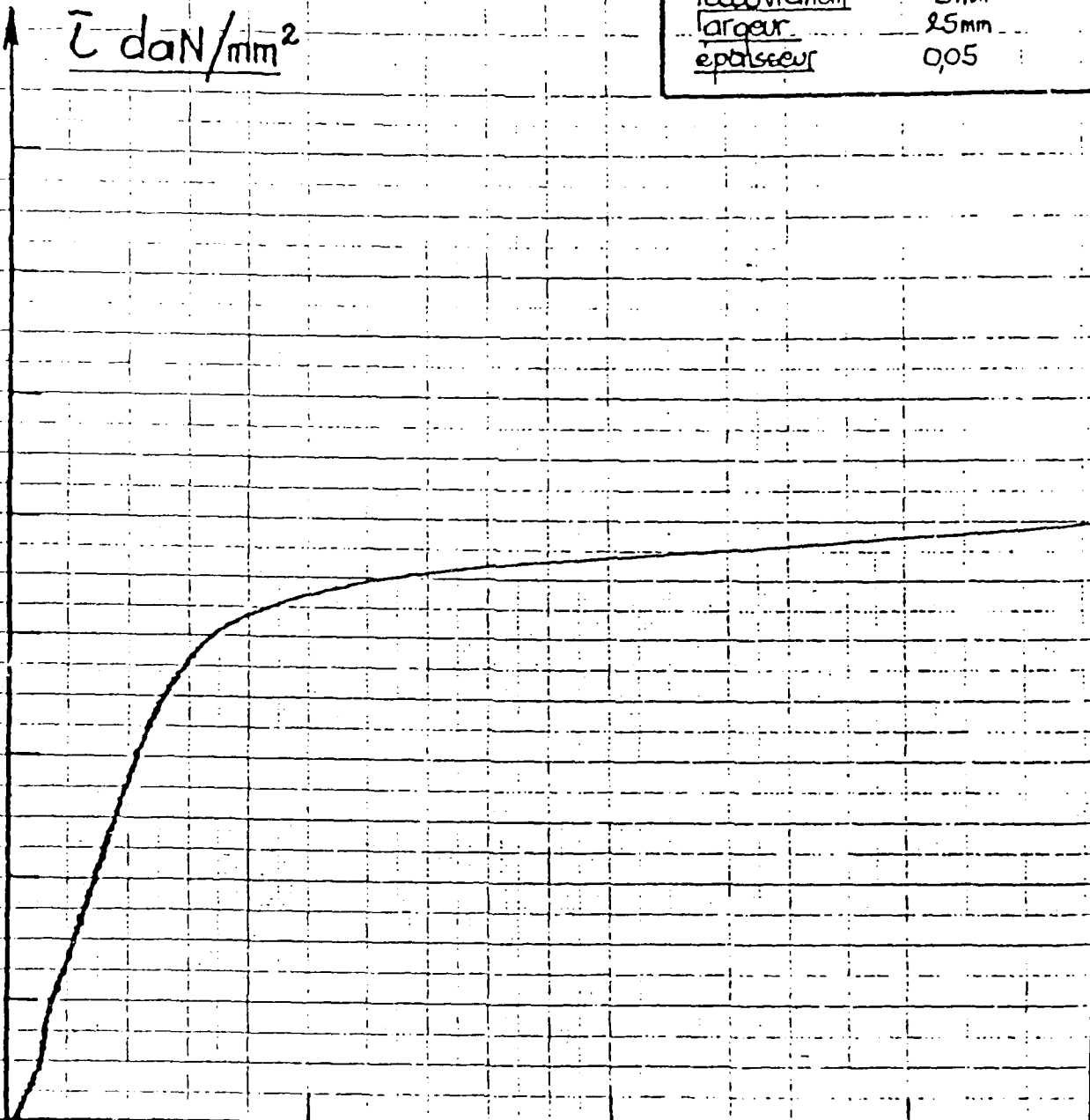

A28

PL10

Adhésif EA 9628
 n° éprouvette 13.2
 recouvrement 5 mm
 largeur 25 mm
 épaisseur 0,04 mm

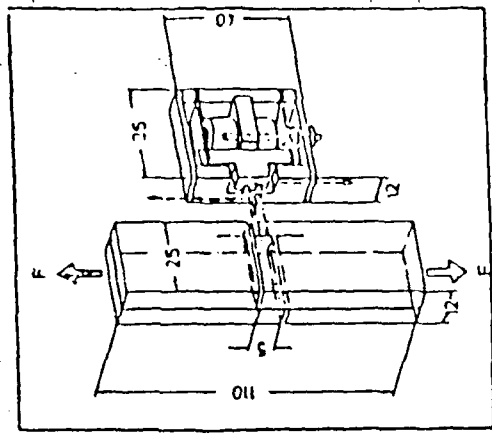
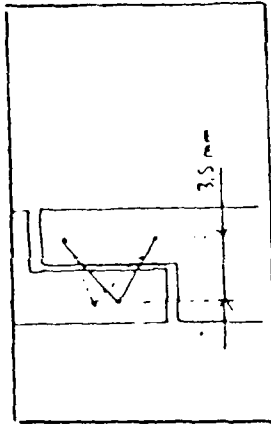

\bar{U} daN/mm²

lg X

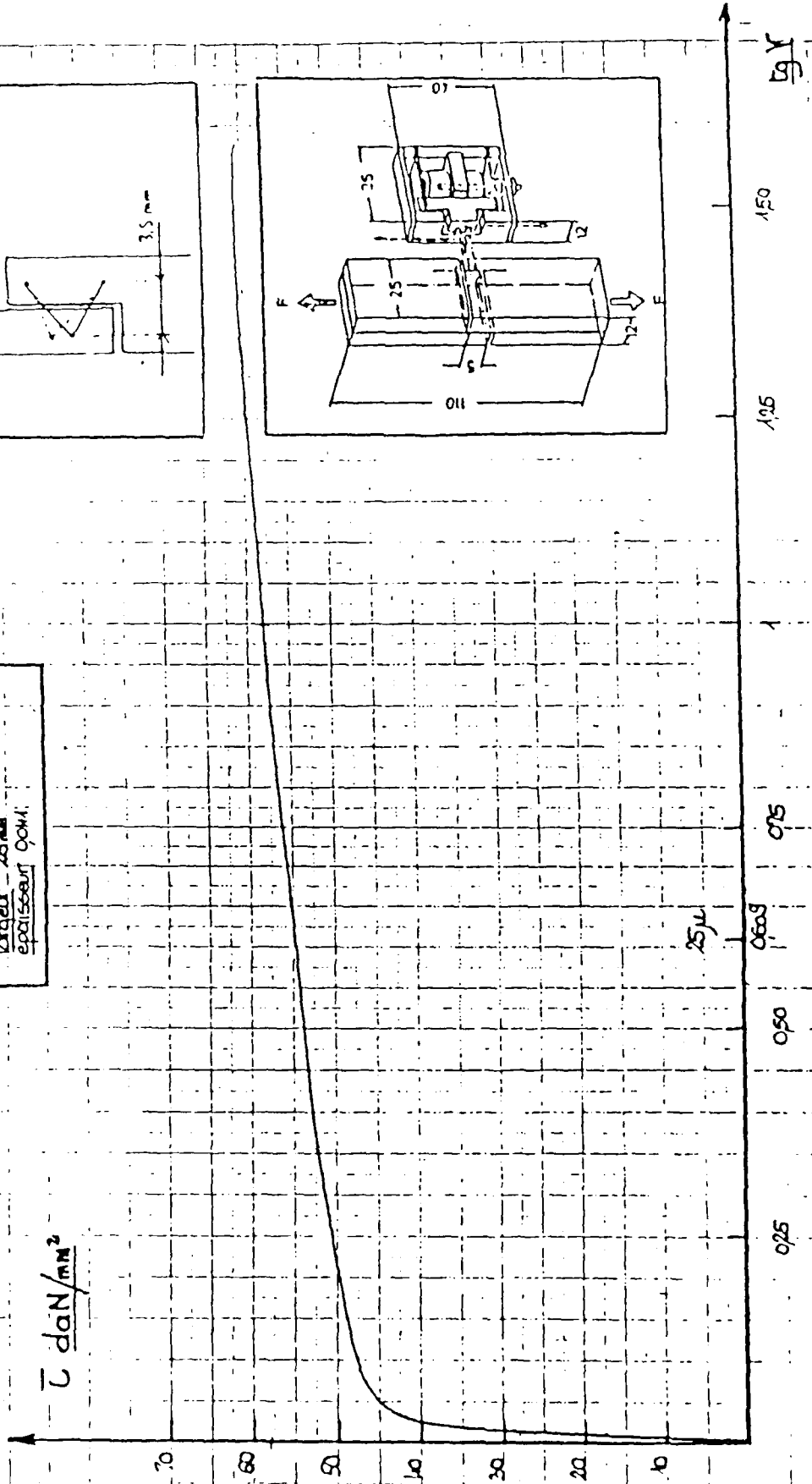

EA 9628

double lap-joint test piece
éprouvette d'étude à double cisaillement type PGQ 006/4

état initial
original condition

$F = 456,25 \text{ N/mm}$

PL 11

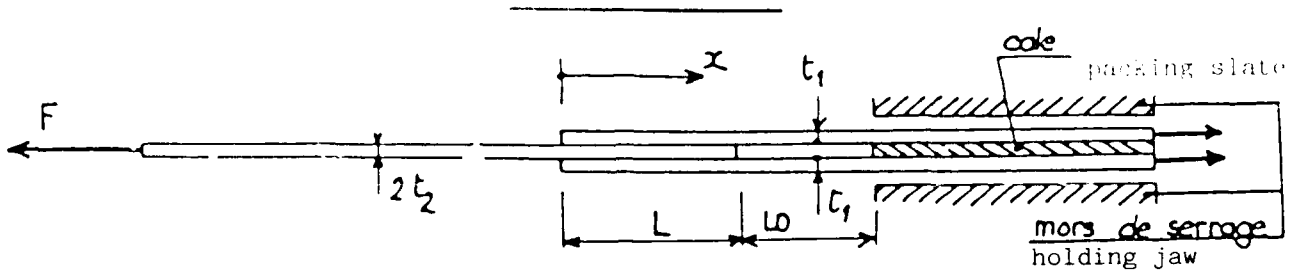

fixed data
données fixes.

adherendis: A-U4G1/A5 - état T3 $E = 72000 \text{ MPa}$ $\nu = 0,25$

adhésif: $E = 2000 \text{ MPa}$ $\nu = 0,32$ soit: $G = 757 \text{ MPa}$

thickness of a layer
épaisseur d'une couche : 0,195 mm

paramètres.

codes: N: standardised normalise C: bond S: adhesive L: length

nb layers adhésif	thickness épaisseur of sheets de tôles	$t_1 = 1,2$	$t_1 = 1,6$	$t_1 = 2$	establishment organisme applying utilisateur process	(mm)
		$2t_2 = 2,4$	$2t_2 = 3$	$2t_2 = 4$		
1		$L = 12,5$ code: S1 nb: 3	$L = 12,5$ code: N nb: 3	$L = 12,5$ code: S2 nb: 3	ARMINES	
2			$L = 12,5$ code: C nb: 3			
1			$L = 12,5$ code: N nb: 3		aérospatiale	
1			$L = 25$ code: L nb: 3			aquitaine

$L_0 = 30 \text{ mm}$

cas $L_0 = 5 \text{ mm}$

LABORATOIRE AGEN
 mechanical tests
 ESSAIS MECANIGUES
 tensile test

ESSAI en TRACTION
 EPROUVETTE : No-1/12.5

calculated

calcul

stress
 $\bar{\sigma}$ CONTRAINTE MPa

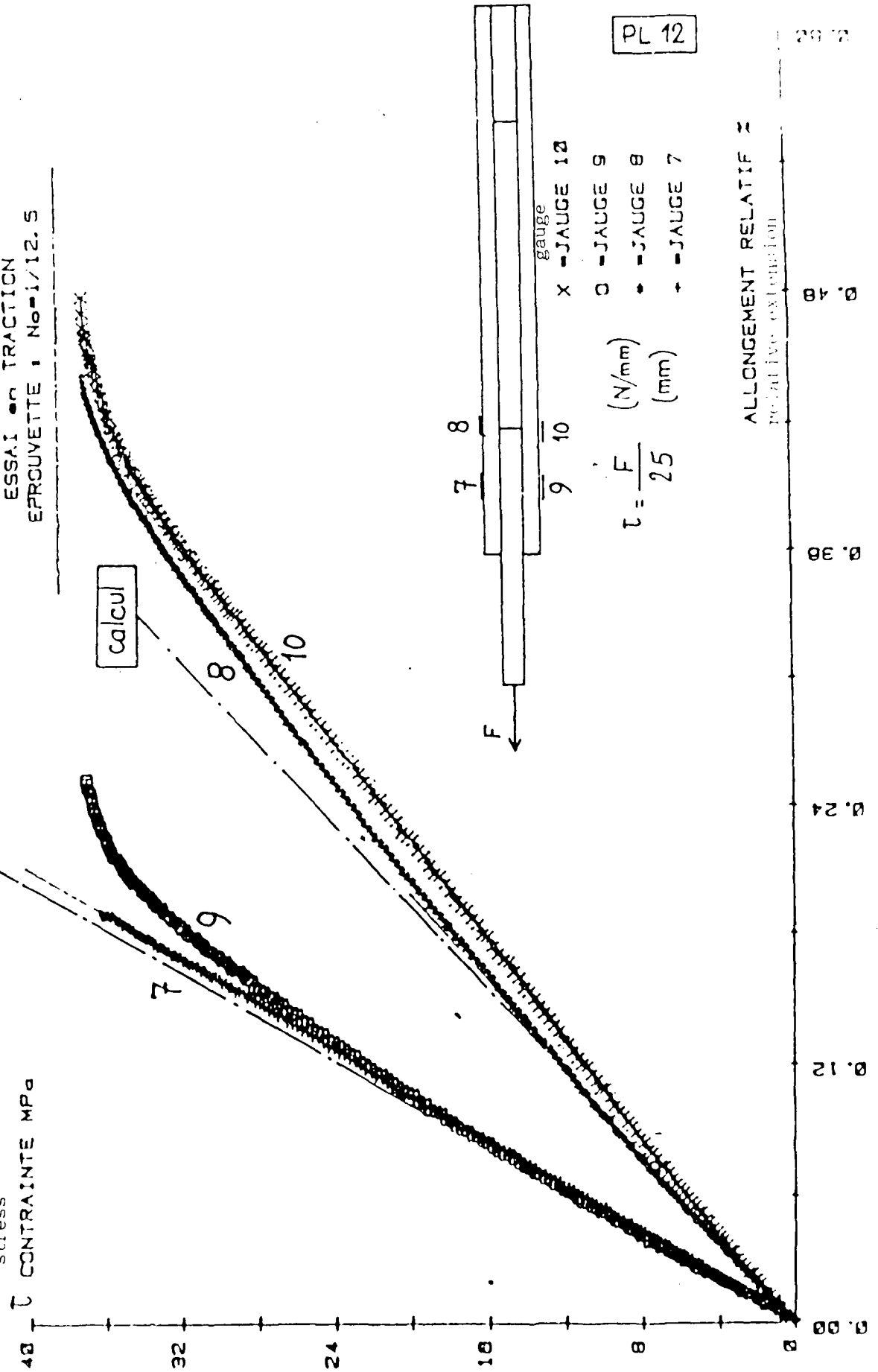

A28

LABORATOIRE AGEN
ESSAIS MECANICIQUES

ESSAI en TRACTION
EPROUVETTE : No 3/12.5

calcul

calcul

40 $\bar{\sigma}$ CONTRAINTE MPa

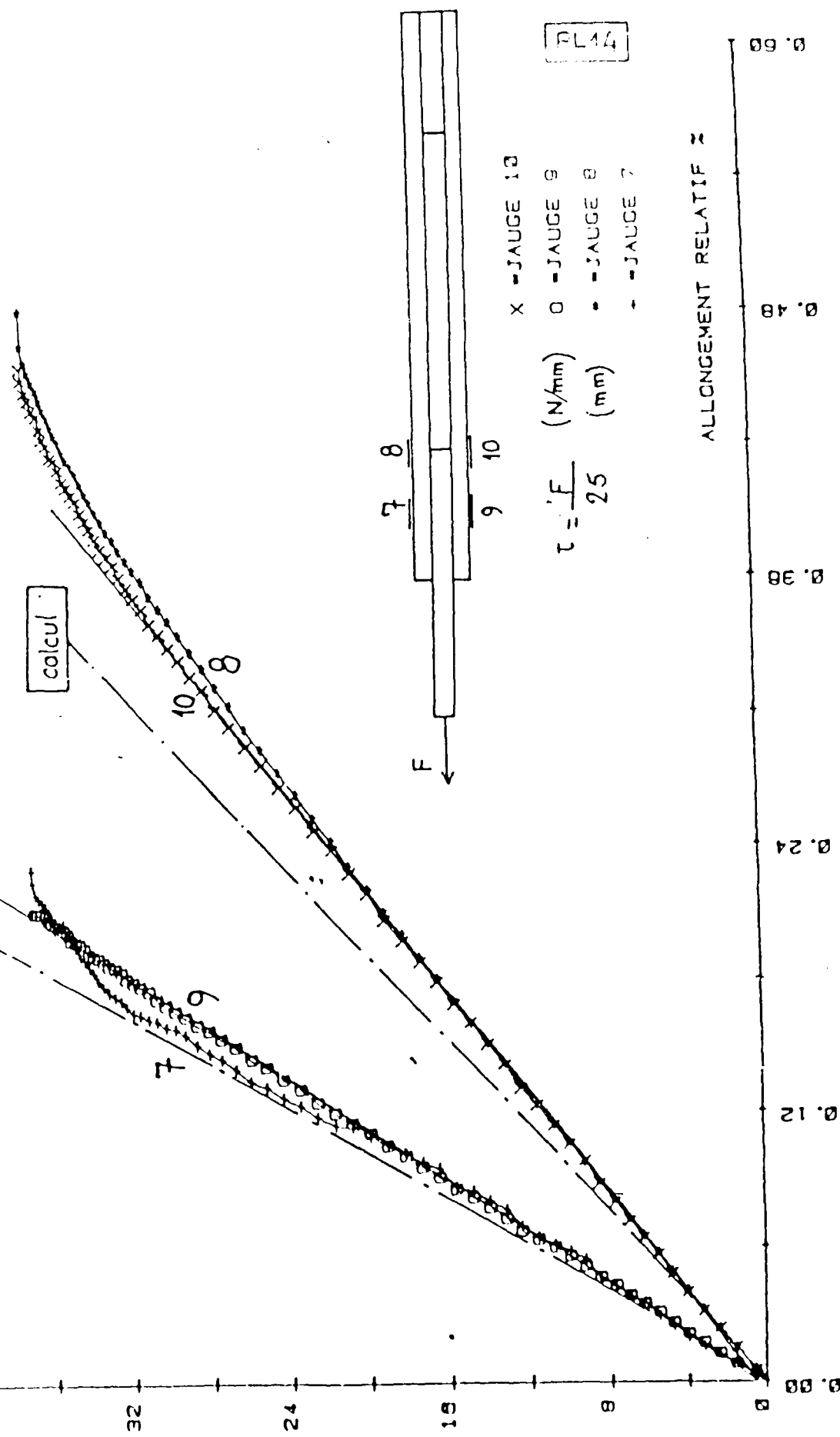

méthode aux éléments finis

finite-element method

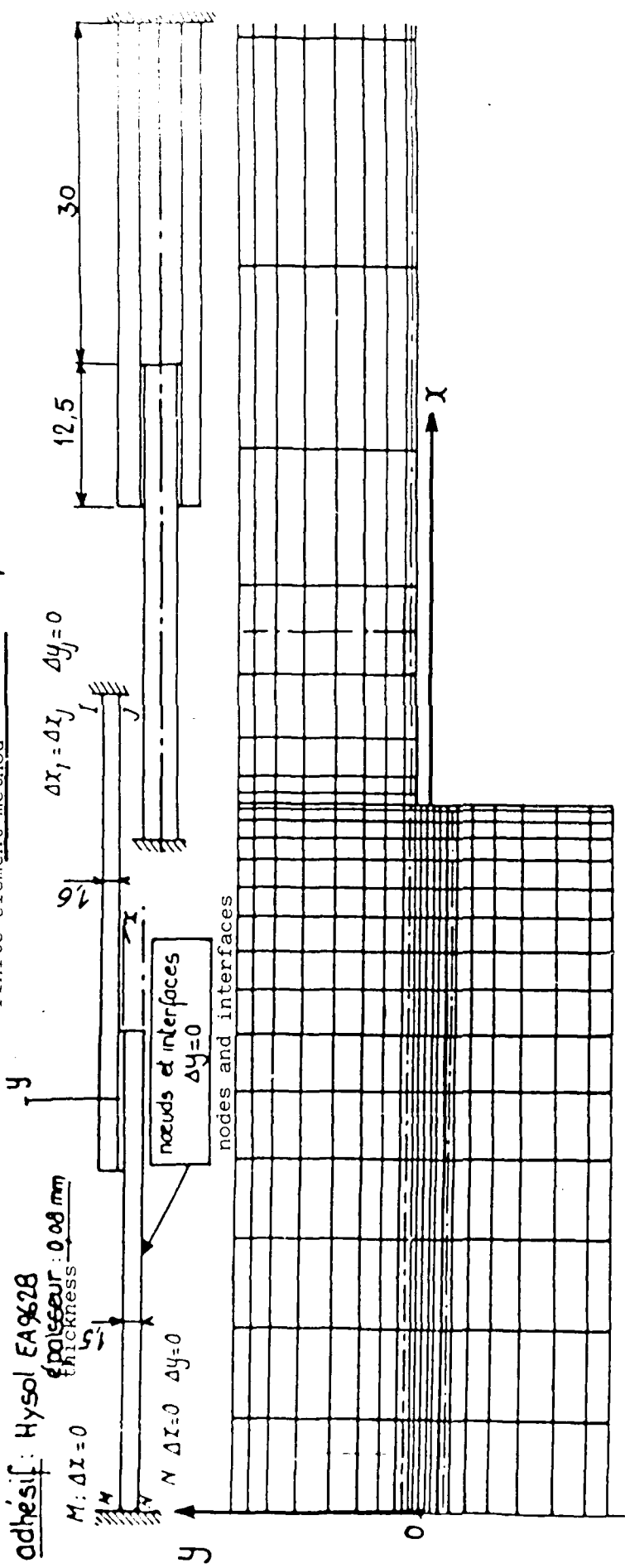

X (mm)	0	0,7	1,4	2,1	2,8	3,5	4,1	4,6	4,95	5,25	5,5	5,75	5,95	6,1	6,2	6,25	6,35	
6,5	6,85	7,4	8,2	9,4	11	13	15	17	19	21	23	25	27	29	31	33	34,5	36,25

X (mm)	0	à	6,25
Y (mm)	±0,008 ±0,024 ±0,04		

X (mm)	36,25		
Y (mm)	±0,14 ±0,29 ±0,49 ±0,74 ±1,04	1,29	1,49
			1,64

X (mm)	0	6,25
Y (mm)	-1,34	-1,54

624	674	724	924	1124	1174	1224	
623	673	723	923	1123	1173	1223	
622	672	722	922	1122	1172	1222	
620	687	721	921	1121	1171	1220	
618	688	720	920	1120	1170	1220	
616	689	719	919	1119	1169	1219	
614	690	718	918	1118	1168	1218	
612	691	717	917	1117	1167	1217	
610	692	716	916	1116	1166	1216	
608	681	708	908	1115	1165	1215	
607	657	707	907	1114	1164	1214	
606	656	706	906	1113	1163	1213	
605	605	705	905	1112	1162	1212	

supplémentary mesh
decoupage complémentaire

X (mm)	6,025	6,15	6,175	6,225	6,275	6,3	6,325	6,425	7,8
--------	-------	------	-------	-------	-------	-----	-------	-------	-----

6,1 à 6,25	6,35	0 à 6,25	7A
±0,065	+0,065	± 0,09	+0,09

X (mm)	6,1 à 6,25
Y (mm)	0 ±0,016 ±0,032

adherends :
supports : E = 72500 MPa
adhesive
adhesif : E = 2000 MPa

force totale :
 ν = 0,3
 F = 100 N/mm
 ν = 0,4

X (mm)	-6,2375	-6,212	-6,187	-6,162	-6,125	-6,075	-5,9875	-5,885	-5,625	-5,375	-5,1	-4,775	-4,35	-3,8	-3,15	-2,45	-1,75	-1,05	-0,35
-----------	---------	--------	--------	--------	--------	--------	---------	--------	--------	--------	------	--------	-------	------	-------	-------	-------	-------	-------

n°	3910	3860	3810	3760	3710	3660	3610	3560	3510	3460	3410	3360	3310	3260	3210	3160	3110	3060	3010
σ_x	40,08	7,85	6,75	6,65	6,49	6,12	5,24	4,17	2,98	2,11	1,45	0,88	0,39	0,04	-0,09	-0,34	0,09	0,24	0,40
σ_y	19,85	9,69	8,48	8,40	8,14	7,51	6,32	4,83	3,19	1,98	1,05	0,25	-0,43	-0,09	-1,05	-0,93	-0,69	-0,42	-0,14
σ_z	11,97	7,02	6,09	6,02	5,85	5,45	4,62	3,60	2,47	1,64	1,0	0,45	-0,02	-0,03	-0,45	-0,39	-0,24	-0,07	0,11
τ_{xy}	10,71	9,48	9,08	8,65	8,08	7,63	7,33	7,02	6,58	6,13	5,7	5,26	4,78	4,24	3,59	3,19	2,81	2,54	2,40

n°	3919	3869	3819	3769	3719	3669	3618	3568	3518	3468	3418	3368	3318	3268	3218	3168	3118	3068	3018
σ_x	-0,24	3,40	5,16	5,70	5,74	5,41	4,70	3,71	2,60	1,79	1,17	0,65	0,19	-0,12	-0,22	-0,15	0,00	0,19	0,38
σ_y	-0,95	6,65	8,51	8,75	8,42	7,75	6,50	4,99	3,32	2,10	1,15	0,34	-0,36	-0,84	-1,0	-0,89	-0,66	-0,40	-0,13
σ_z	-0,48	4,02	5,47	5,78	5,66	5,27	4,48	3,48	2,37	1,56	0,93	0,39	-0,07	-0,38	-0,49	-0,42	-0,26	-0,08	0,10
τ_{xy}	2,68	4,82	6,54	7,43	7,93	8,09	7,87	7,44	6,84	6,31	5,83	5,35	4,83	4,26	3,69	3,18	2,79	2,52	2,38

double-joint assembly
 assemblage à double joint - F = 100 N/mm

plan strain condition

état plan de déformation joint de colle - 6,25 < x < 0

résultats numériques des contraintes (MPa)
 numerical results of stress

PL17

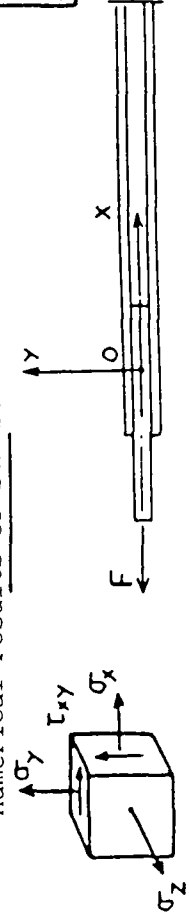

n°	3914	3864	3814	3764	3714	3664	3614	3564	3514
σ_x	0,57	2,70	4,34	5,20	5,66	5,63	4,99	3,97	2,80
σ_y	7,11	9,08	9,18	8,98	8,48	7,70	6,41	4,90	3,25
σ_z	3,08	4,71	5,41	5,64	5,66	5,33	4,56	3,55	2,42
τ_{xy}	4,15	8,27	8,60	8,11	8,06	7,87	7,60	7,23	6,71

X (mm)	0,35	1,05	1,75	2,45	3,15	3,8	4,35	4,775	5,1	5,375	5,625	5,85	5,9875	6,075	6,125	6,162	6,187	6,212	6,2375
-----------	------	------	------	------	------	-----	------	-------	-----	-------	-------	------	--------	-------	-------	-------	-------	-------	--------

n°	10	60	110	160	210	260	310	360	410	460	510	560	610	660	710	760	810	860	910
σ_x	0,56	0,71	0,86	0,96	0,95	0,72	0,27	-0,3	-0,86	-1,40	-1,88	-2,23	-2,30	-2,22	-2,01	-1,82	-1,79	-2,60	-4,49
σ_y	0,13	0,41	0,66	0,86	0,88	0,57	-0,01	-0,95	-1,82	-2,65	-3,42	-3,99	-4,16	-4,01	-3,76	-3,42	-3,25	-4,11	-10,92
σ_z	0,28	0,45	0,61	0,73	0,73	0,52	0,01	-0,50	-1,07	-1,62	-2,12	-2,49	-2,58	-2,49	-2,31	-2,09	-2,02	-2,68	-6,16
τ_{xy}	2,39	2,51	2,76	3,12	3,58	4,09	4,56	4,96	5,29	5,60	5,92	6,26	6,53	6,78	6,96	7,07	6,96	6,49	5,94

n°	18	68	118	168	218	268	318	368	418	468	518	568	618	669	719	769	819	869	919
σ_x	0,38	0,76	0,93	1,07	1,08	0,87	0,43	-0,11	-0,65	-1,17	-1,63	-1,93	-1,96	-1,77	-1,52	-1,17	-0,65	0,83	3,57
σ_y	-0,13	0,39	0,64	0,82	0,84	0,52	-0,16	-1,02	-1,89	-2,73	-3,51	-4,09	-4,26	-4,14	-3,91	-3,60	-3,13	-1,45	6,02
σ_z	0,10	0,46	0,63	0,75	0,76	0,56	0,11	-0,45	-1,02	-1,56	-2,05	-2,41	-2,48	-2,36	-2,17	-1,91	-1,51	-0,25	3,84
τ_{xy}	2,38	2,50	2,75	3,12	3,59	4,12	4,63	5,06	5,41	5,73	6,03	6,32	6,47	6,49	6,45	6,29	5,95	5,25	4,78

assemblage à double joint - $F = 100 \text{ N/mm}$

état plan de déformation. joint de colle. $0 < x < 6,25$

résultats numériques des contraintes (MPa)

n°	514	564	614	664	714	764	814	864	914
σ_x	-1,75	-2,07	-2,09	-1,89	-1,60	-1,25	-0,92	-0,50	-0,1
σ_y	-3,46	-4,04	-4,22	-4,11	-3,89	-3,589	-3,28	-2,83	-1,99
σ_z	-2,09	-2,44	-2,52	-2,40	-2,19	-1,93	-1,68	-1,33	-0,83
τ_{xy}	5,98	6,52	6,50	6,64	6,74	6,91	7,09	6,76	3,37

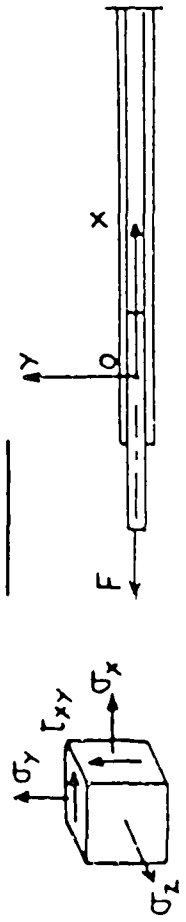

double joint assembly
assemblage à double joint

$F = 100 \text{ N/mm}$

normal stress
contrainte normale σ_y

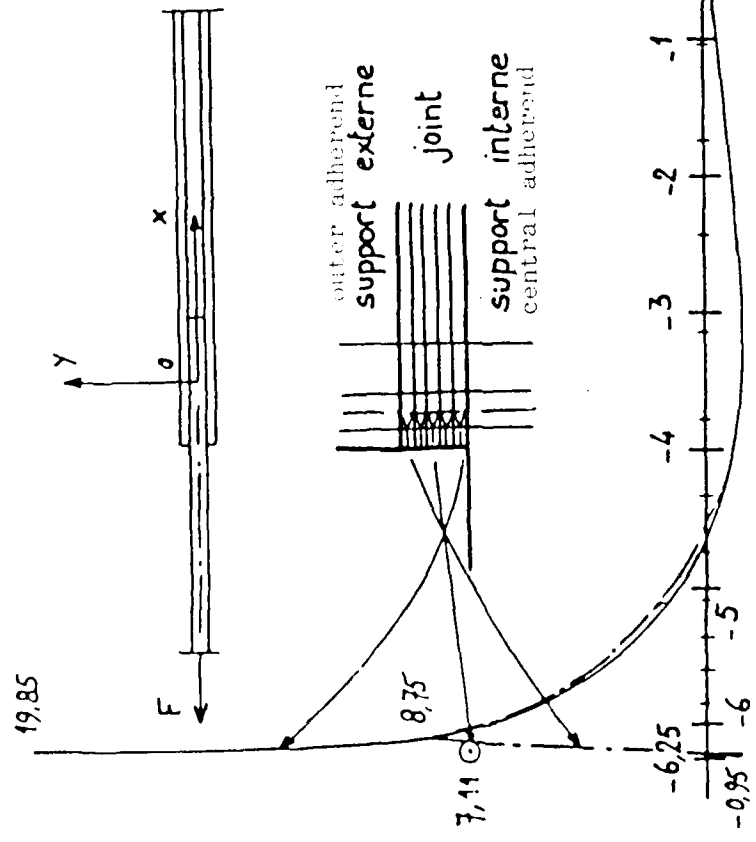
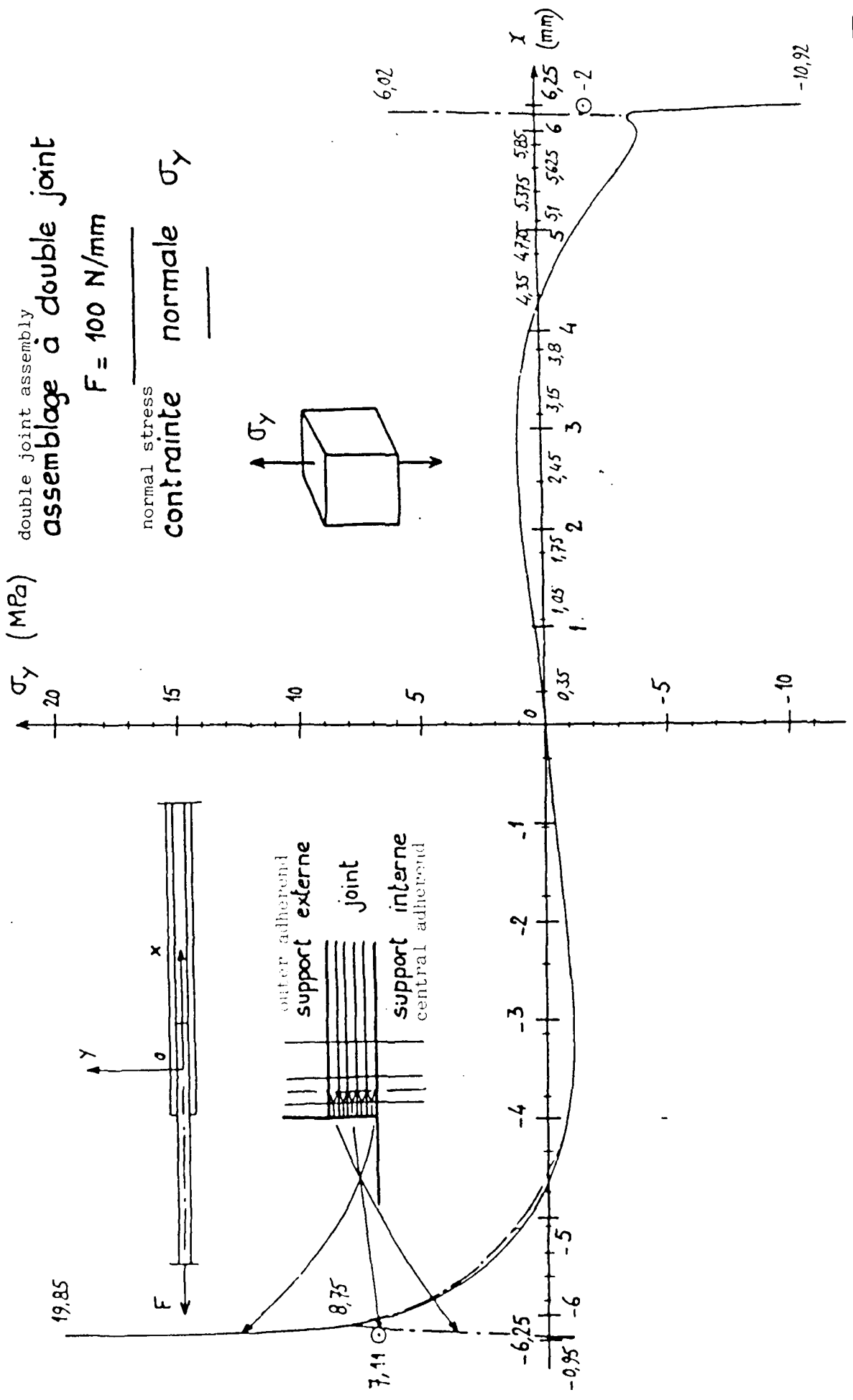
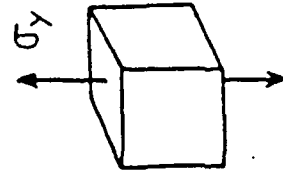

double-joint assembly
assemblage à double joint

$F = 100 \text{ N/mm}$

shear stress
contrainte de cisaillement τ_{xy}

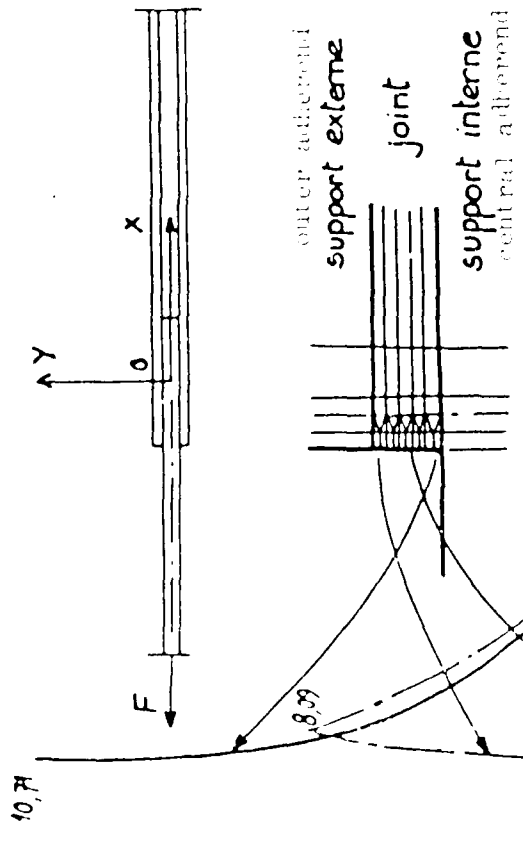
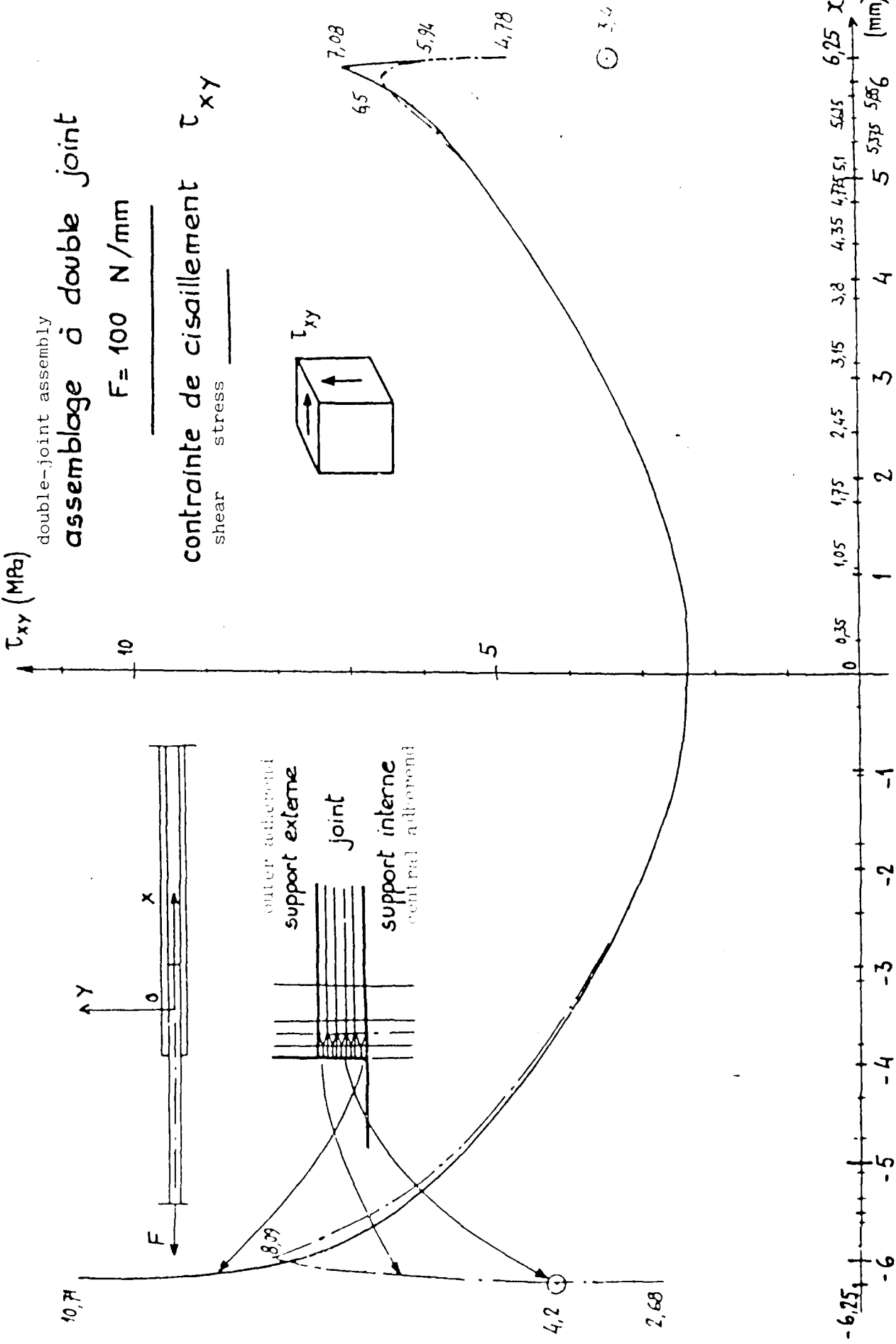
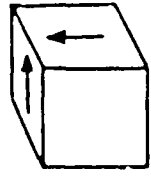

010081

DATA
VALUES

C1= 1.5 L0= 30
 T1= 1.6 T2= 1.5
 E1= 72500 E2= 72500 E3= 2000
 M0= 1 M1= 3
 B1= 1 B2= 1
 T5= 42 S16= 189
 G1= 27884 G2= 27884
 K0= 1 L1= 0
 L2= 0 L4= 1
 L1= 3 L2= 3 L3= 1.2
 R= 17
 F= 50 L5= 1

RESULTS results

F= 50 C6= 1

F= 1
 Y= -2.71346414236 Z= 11.1081577707 Z= 9.05829591579
 W6= 20.5086635747 W8= 21.1360238035 P= 0
 S= 2.42824208504 R= 4.31466416355E-4 G= 714.285714286 E= 2000

K= 11
 Y= 10.0790773422 Z= -7.34388239417 S= 10.5473941121
 R= -3.49905156799E-4 W6= 4.72154538558 W8= -17.1357255863 P= 0
 G= 714.285714286 E= 2000 Y(N+1)= 2.21627237143 Z(N+1)= -5.40965185916

F= 50
C6= 1

K= 1 X= 0
 Y= 11.1081577707 Z= 9.05829591579 I= 20.5086635747
 K= 2 X= 1.306103182138
 Y= 10.2495200896 Z= 6.7569863475 I= 16.6849976444
 K= 3 X= 1.695689050314
 Y= 9.29815420799 Z= 4.09267226206 I= 12.2106803721
 K= 4 X= 1.19152560981
 Y= 7.19185350021 Z= 1.36960220362 I= 7.67390926881
 K= 5 X= 1.8225993219
 Y= 5.03855855147 Z= -3.31355370203 I= 3.99978067579
 K= 6 X= 2.62576359183
 Y= 3.42186670458 Z= -1.69451170586 I= 1.83779550371
 K= 7 X= 3.64798411721
 Y= 2.13438411348 Z= -1.64123091386 I= .970567915847
 K= 8 X= 4.948920586
 Y= 1.56369733053 Z= -.702059883322 I= .917003420695

K= 9 X= 6.24999999999
 Y= 1.46545040483 Z= 1.24035076026E-2 I= 1.31361646057
 K= 10 X= 7.55100794138
 Y= 1.66441468128 Z= .661794381844 I= 2.10845492715
 K= 11 X= 9.85201586277
 Y= 2.12684537348 Z= 1.40738710624 I= 3.51915066962
 K= 12 X= 9.87423640815
 Y= 3.40880929088 Z= 1.51333488977 I= 4.60848168271
 K= 13 X= 10.6774096781
 Y= 5.03874208693 Z= .527505612367 I= 4.95692183795
 K= 14 X= 11.3064743902
 Y= 6.7287029903 Z= -1.33457637831 I= 4.94885247334
 K= 15 X= 11.8043109497
 Y= 8.19523129442 Z= -3.53808205828 I= 4.87812094408
 K= 16 X= 12.1938968179
 Y= 9.31227977564 Z= -5.62284988327 I= 4.80271571008
 K= 17 X= 12.5
 Y= 10.0790773422 Z= -7.34388239417 I= 4.72154538558

FIN DES CALCULS
end of calculations

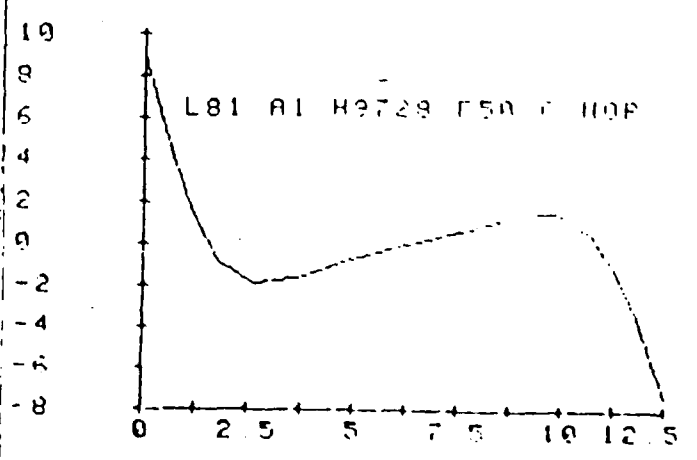
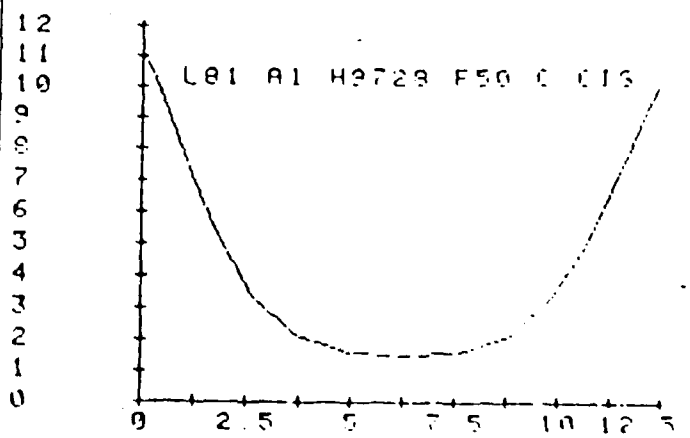

double-joint: assembly

assemblage à double joint

$F = 100 \text{ N/mm}$

relative extension, along ox , of external surfaces of

allongement relatif, suivant ox , des faces extérieures des

stresses

supports externes $-6,25 < x < 6,25$ contraintes (MPa)

X (mm)	-6,2375	-6,212	-6,187	-6,162	-6,125	-6,075	-5,9875	-5,85	-5,625	-5,375	-5,1	-4,775	-4,35	-3,8	-3,15	-2,45	-1,75	-1,05	-0,35
n° de l'élément	3929	3879	3829	3779	3729	3679	3629	3579	3529	3479	3429	3379	3329	3279	3229	3179	3129	3079	3029
σ_x	$-7,876 \cdot 10^{-4}$	$-1,048 \cdot 10^{-2}$	$-2,718 \cdot 10^{-2}$	$-5,44 \cdot 10^{-2}$	$-1,007 \cdot 10^{-1}$	$-2,133 \cdot 10^{-1}$	$-3,844 \cdot 10^{-1}$	$-7,416 \cdot 10^{-1}$	$-1,216 \cdot 10^{-1}$	$-1,346 \cdot 10^{-1}$	$-9,113 \cdot 10^{-1}$	$2,053 \cdot 10^{-1}$	$2,203 \cdot 10^{-1}$	$4,984 \cdot 10^{-1}$	$7,975 \cdot 10^{-1}$	$10,59 \cdot 10^{-1}$	$12,61 \cdot 10^{-1}$	$14,18 \cdot 10^{-1}$	$15,48 \cdot 10^{-1}$
σ_z	$-5,234 \cdot 10^{-3}$	$-1,645 \cdot 10^{-2}$	$-2,486 \cdot 10^{-2}$	$-3,295 \cdot 10^{-2}$	$-4,681 \cdot 10^{-2}$	$-7,635 \cdot 10^{-2}$	$-1,219 \cdot 10^{-1}$	$-2,206 \cdot 10^{-1}$	$-3,56 \cdot 10^{-1}$	$-3,936 \cdot 10^{-1}$	$-2,656 \cdot 10^{-1}$	$6,568 \cdot 10^{-2}$	$6,614 \cdot 10^{-1}$	$1,494 \cdot 10^{-1}$	$2,391 \cdot 10^{-1}$	$3,176 \cdot 10^{-1}$	$3,781 \cdot 10^{-1}$	$4,252 \cdot 10^{-1}$	$4,644 \cdot 10^{-1}$
$10^3 \varepsilon_x (\%)$	1,079	7,648	-2,72	-5,684	-1,195	-2,626	-4,797	-9,316	-1,53	-1,693	-1,147	2,56	2,765	6,256	1,001	1,329	1,582	1,78	1,943

X (mm)	0,35	1,75	2,45	3,15	3,8	4,35	4,775	5,1	5,375	5,625	5,85	5,9875	6,075	6,125	6,162	6,187	6,212	6,2375	
n° de l'élément	29	79	129	179	229	279	329	379	429	479	529	579	629	679	729	779	829	879	929
σ_x	16,7	18,01	19,6	21,62	24,19	27,01	29,46	31,06	31,86	32,12	31,98	31,6	31,29	30,94	30,84	30,78	30,71	30,65	
σ_z	5,011	5,405	5,88	6,486	7,258	8,103	8,836	9,313	9,551	9,629	9,589	9,477	9,384	9,281	9,253	9,234	9,215	9,196	
$10^3 \varepsilon_x (\%)$	2,096	2,26	2,46	2,713	3,036	3,39	3,697	3,898	3,999	4,031	4,014	3,966	3,927	3,903	3,883	3,871	3,854	3,847	



$$\varepsilon_x = \frac{1}{E} \cdot (\sigma_x - \nu \cdot \sigma_z)$$

$E = 72500 \text{ MPa}$ $\nu = 0,3$

middle of test piece

milieu de l'éprouvette $x = 0$ (interpolation) : $\varepsilon_x = 0,02019 \%$

abscissa of free end of central adherend

$x = 6,25 \text{ mm}$ (interpolation) : $\varepsilon_x = 0,03843 \%$

gauge \rightarrow Jauges 7 et 9

gauge

\rightarrow Jauges 8 et 10

$10^2 \epsilon_x$ (%)

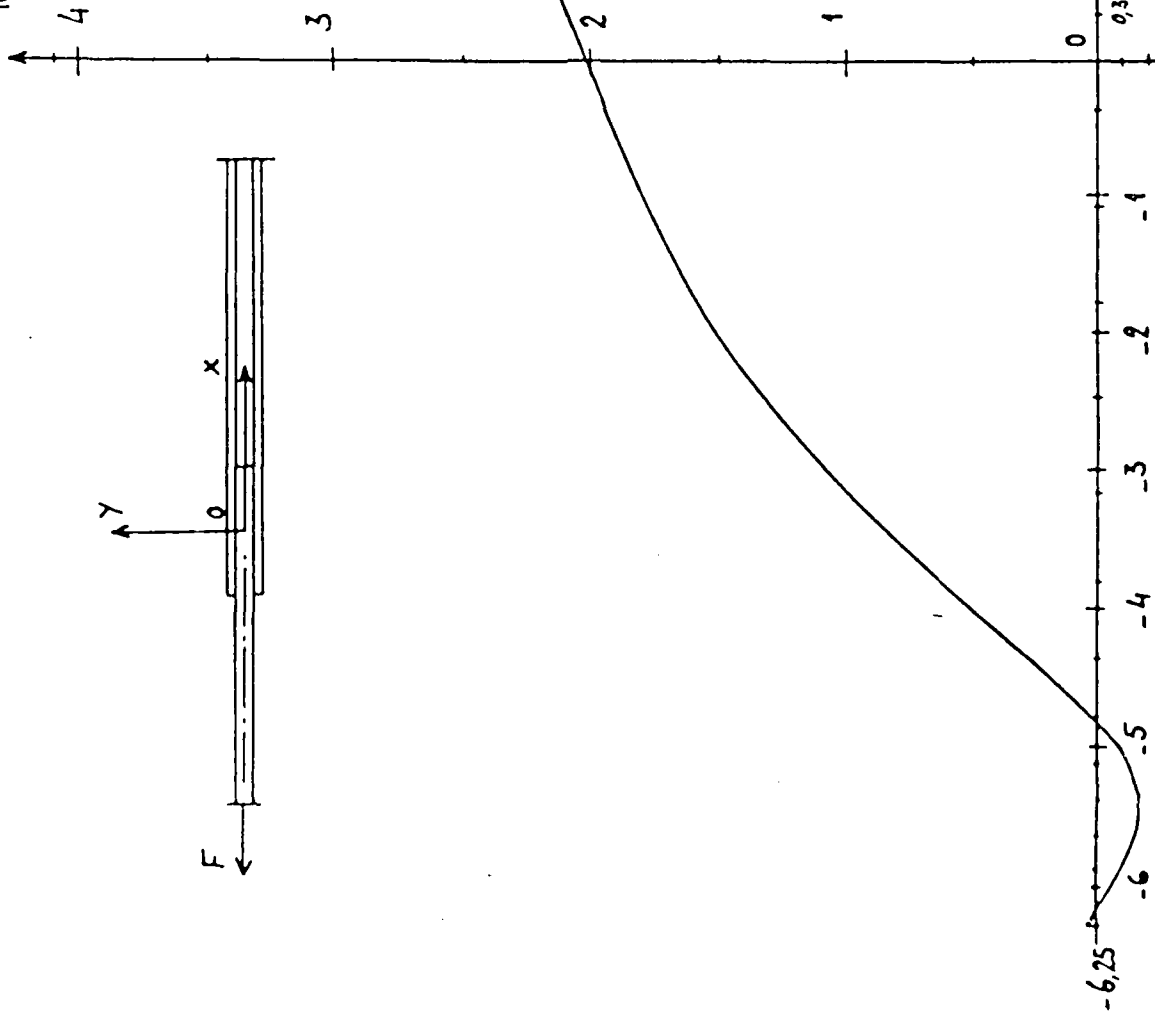

double-joint assembly
assemblage à double joint

$F = 100 \text{ N/mm}$

relative extension, along OX of the outer
allongement, relatif, suivant OX, des faces
extérieures des supports externes. $-6.25 < x < 6.25$
surfaces of the outer adherends

311
A38

PL24

file
FICHER P0

Q0= 10
Q= 1 E5= 0 Y2= 0 N5= .4
Q= 2 E5= .00609 Y2= 13 N5= .4
Q= 3 E5= .0101 Y2= 20.7 N5= .4
Q= 4 E5= .016 Y2= 30.7 N5= .4
Q= 5 E5= .0241 Y2= 40.5 N5= .4
Q= 6 E5= .0281 Y2= 43.7 N5= .4
Q= 7 E5= .0321 Y2= 46.1 N5= .4
Q= 8 E5= .036 Y2= 47.8 N5= .4
Q= 9 E5= .044 Y2= 49.6 N5= .4
Q= 10 E5= .0572 Y2= 49.8 N5= .4
Q0= 10
Q= 1 E5= 0 Y2= 0 N5= .4
Q= 2 E5= .00609 Y2= 13 N5= .4
Q= 3 E5= .0101 Y2= 20.7 N5= .4
Q= 4 E5= .016 Y2= 30.7 N5= .4
Q= 5 E5= .0241 Y2= 40.5 N5= .4
Q= 6 E5= .0281 Y2= 43.7 N5= .4
Q= 7 E5= .0321 Y2= 46.1 N5= .4
Q= 8 E5= .036 Y2= 47.8 N5= .4
Q= 9 E5= .044 Y2= 49.6 N5= .4
Q= 10 E5= .0572 Y2= 49.8 N5= .4

file
FICHER P1

Q0= 10
Q= 1 E5= 0 Y2= 0 N5= .4 L6= 3.795
Q= 2 E5= .00609 Y2= 13 N5= .4 L6= 3.795
Q= 3 E5= .0101 Y2= 20.7 N5= .4 L6= 3.795
Q= 4 E5= .016 Y2= 30.7 N5= .4 L6= 3.795
Q= 5 E5= .0241 Y2= 40.5 N5= .4 L6= 3.795
Q= 6 E5= .0281 Y2= 43.7 N5= .4 L6= 3.795
Q= 7 E5= .0321 Y2= 46.1 N5= .4 L6= 3.795
Q= 8 E5= .036 Y2= 47.8 N5= .4 L6= 3.795
Q= 9 E5= .044 Y2= 49.6 N5= .4 L6= 3.795
Q= 10 E5= .0572 Y2= 49.8 N5= .4 L6= 3.795
Q0= 10
Q= 1 E5= 0 Y2= 0 N5= .4 L6= 3.795
Q= 2 E5= .00609 Y2= 13 N5= .4 L6= 3.795
Q= 3 E5= .0101 Y2= 20.7 N5= .4 L6= 3.795
Q= 4 E5= .016 Y2= 30.7 N5= .4 L6= 3.795
Q= 5 E5= .0241 Y2= 40.5 N5= .4 L6= 3.795
Q= 6 E5= .0281 Y2= 43.7 N5= .4 L6= 3.795
Q= 7 E5= .0321 Y2= 46.1 N5= .4 L6= 3.795
Q= 8 E5= .036 Y2= 47.8 N5= .4 L6= 3.795
Q= 9 E5= .044 Y2= 49.6 N5= .4 L6= 3.795
Q= 10 E5= .0572 Y2= 49.8 N5= .4 L6= 3.795

X28

PL 25

LIC081

data
DONNEES

L= 7.5 L0= 30
T= .02 T1= 1.6 T2= 1.5
E1= 72500 E2= 72500 E6= 2134.6
N0= .4 H1= .3
B1= 1 B2= 1
Y5= 49.8 Y6= 189
G1= 27884 G2= 27884
K0= 0 K1= 0
K3= 1 K4= 1
H= 17
F= 10 C5= 40

RESULTS results

F= 10 C6= 1
K=1
Y(0)=-.572832582443 Y=
2.56054338940 Z= 2.05611509128
W6= 4.6698059657 W8=
4.79760187965 P= 0
S= 10.6642546534 R=
9.55170995809E-5 G=
762.373915086 E= 2134.64696223

K=H
Y= 2.06314640494 Z=
-1.69433748845 S= 55.0971623545
R=-7.87106730038E-5 W6=
993857800871 W8=
-3.95345413972 P= 0
G= 762.373915086 E=
2134.64696223 Y(N+1)=
446638252955 Z(N+1)=
-1.37942111098

F= 100 C6= 19
L=1
Y(0)= 1.01155360481 Y=
36.7767751265 Z= 16.4011374269
W6= 49.8087492117 W8=
38.2693206628 P= 0
S= .999824343879 R=
7.71969241852E-4 G=
5.41125541125 E= 15.15151515

K=H
Y= 42.4152952044 Z=-14.89664925
S= 1.83726948906 R=
-7.12705964192E-4 W6=
27.1054411433 W8=-34.75884825
P= 0
G= 695.326876514 E=
1694.91525424 Y(N+1)=
5.07155149961 Z(N+1)=
-232578631371

F= 100.90334909
C6= 18.930334909

K= 1 X= 0
Y= 36.7749545091 Z=
16.3951485283 I= 49.8
K= 2 X= .46875
Y= 36.9623847758 Z=

K= 6 X= 2.34375
Y= 22.502173629 Z=
5.57264295976 I= 25.5485321429
K= 7 X= 2.8125
Y= 18.2978743759 Z=
3.60137019341 I= 19.8430916349
K= 8 X= 3.28125
Y= 15.296725333 Z= 1.6864318694
I= 15.302729158
K= 9 X= 3.75
Y= 13.8094746633 Z=
-.161865970303 I= 12.3239730628
K= 10 X= 4.21875
Y= 14.013732661 Z=
-2.01459672912 I= 11.0396400255
K= 11 X= 4.6875
Y= 15.9394909056 Z=
-3.80937982693 I= 11.4291123547
K= 12 X= 5.15625
Y= 19.391993361 Z=
-5.81124738417 I= 13.1953765117
K= 13 X= 5.625
Y= 23.8683188969 Z=
-7.76304146425 I= 15.8305826983
K= 14 X= 6.09375
Y= 28.9355145451 Z=
-9.74098596776 I= 18.9731159566
K= 15 X= 6.5625
Y= 34.1236024582 Z=
-11.6676760855 I= 22.2512402172
K= 16 X= 7.03125
Y= 38.6772987592 Z=
-13.3763343542 I= 25.0933708059
K= 17 X= 7.5
Y= 42.0094637278 Z=
-14.7794036768 I= 27.1006799067

FIN DES CALCULS
end of calculations

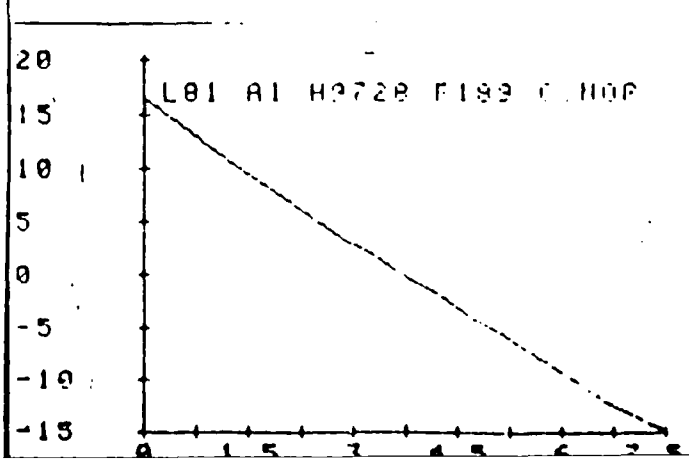
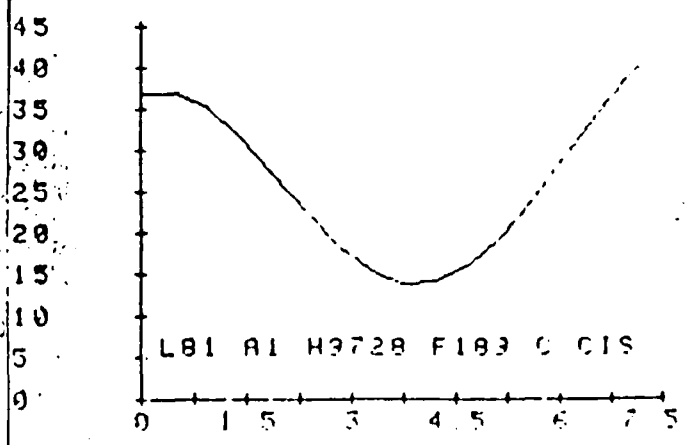

AVB

PL26

LIC082

DONNEES data

 L= 7.5 L0= 30
 T= 08 T1= 1.6 T2= 1.5
 E1= 72500 E2= 72500 E6= 2134.6
 H0= 4 H1= 3
 B1= 1 B2= 1
 Y5= 42.8 Y6= 189
 G1= 27884 G2= 27884
 K0= 0 K1= 0
 K3= 1 K4= 1
 H= 17
 F= 10 C5= 40

RESULTS results

F= 10 C6= 1

 K=1
 Y(0)=- 572832582443 Y=
 2.56854538848 Z= 2.05611509128
 W6= 4.60178704866 W8=
 4.79760167965 P= 0
 S= 10.8218827758 R=
 9.55178995809E-5 G=
 762.373915086 E= 2134.64696223

K=N
 Y= 2.06314640494 Z=
 -1.69433748845 S= 60.0200924592
 R=-7.87106739838E-5 W6=
 .82972214736 W8=-3.95345413972
 P= 0
 G= 762.373915086 E=
 2134.64696223 Y(N+1)=
 .446638252955 Z(N+1)=
 -1.37942111098

F= 180 C6= 18

 K=1
 Y(0)= 4.98344874887 Y=
 33.420513393 Z= 15.1979040026
 W6= 42.7681263954 W8=
 35.461776006 P= 0
 S= 1.00064044212 R=
 7.18841503645E-4 G=
 5.41125541125 E= 15.1515151515

K=N
 Y= 42.0861534827 Z=
 -14.2286352917 S= 1.47438601534
 R=-6.88250972022E-4 W6=
 33.7767710101 W8=
 -33.3634837707 P= 0
 G= 432.098765432 E=
 1209.87654321 Y(N+1)=
 6.57198160298 Z(N+1)=
 .456288370403

F= 190 C6= 19

 K=1
 Y(0)= 5.09885083592 Y=
 33.427324547 Z= 15.1977284447
 W6= 49.7753969022 W8=
 35.461366371 P= 0
 S= 1.0004942823 R=
 7.18831601307E-4 G=
 5.41125541125 E= 15.1515151515

K=N
 Y= 45.9155266384 Z=
 -14.980226478 S= 1.32908906521
 R=-7.29025433397E-4 W6=
 37.4692722282 W8=-34.953861792
 P= 0
 G= 432.098765432 E=
 1209.87654321 Y(N+1)=
 8.13825893415 Z(N+1)=
 1.03262566626

F= 200 C6= 20

 K=1
 Y(0)= 5.22529934632 Y=
 33.434754443 Z= 15.1716292711
 W6= 49.7685909594 W8=
 35.4004659658 P= 49.7753969022
 S= 1.00079197292 R=
 7.17269619495E-4 G=
 762.357142857 E= 2134.6

K=N
 Y= 49.8337494485 Z=
 -15.5537448074 S= 1.21687006084
 R=-7.87263889517E-4 W6=
 40.9246653382 W8=
 -37.2254045507 P= 0
 G= 285.714285714 E= 800 Y(N+1)=
 8.40016189243 Z(N+1)=
 1.20191726606

F= 210 C6= 21

 K=1
 Y(0)= 4.85756986479 Y=
 33.3290466042 Z= 16.5760848688
 W6= 50.8791297792 W8=
 38.6775313605 P= 49.7753969022
 S= .978790325544 P=
 8.23491739101E-4 G=
 762.357142857 E= 2134.6

K=N
 Y= 52.9981332336 Z=
 -17.1470205098 S= 1.14823756403
 R=-8.77513936894E-4 W6=
 43.3708159008 W8=
 -40.8097145220 P= 0
 G= 285.714285714 E= 800 Y(N+1)=
 4.23199403117 Z(N+1)=
 2.05788158119

ADD

PL 27

F= 200 359960737
C6= 20.0359960737

```

-----
K= 1 X= 0
Y= 33.4309493758 Z=
  15 2221831943 I= 49.8
K= 2 X= .46875
Y= 33.9107862632 Z=
  13 8232645798 I= 48.1749808607
K= 3 X= .9375
Y= 32.5532408557 Z=
  12 2948982235 I= 45.4580895621
K= 4 X= 1.40625
Y= 23.7262245699 Z=
  10 5249567935 I= 41.1638702525
K= 5 X= 1.875
Y= 26.4127888893 Z=
   9 73385679378 I= 36.4201606351
K= 6 X= 2.34375
Y= 23.1322963852 Z=
   6 88158324361 I= 31.5699901733
K= 7 X= 2.8125
Y= 20.050362152 Z=
   4 98209051275 I= 27.2096855898
K= 8 X= 3.28125
Y= 18.5350524101 Z=
   2 87618652765 I= 24.2191694526
K= 9 X= 3.75
Y= 18.2465651511 Z=
  734194463153 I= 22.6625692742
K= 10 X= 4.21875
Y= 19.7739056847 Z=
 -1 5134186282 I= 22.8047732128
K= 11 X= 4.6875
Y= 22.8669060244 Z=
 -3 86976006148 I= 24.2766434989
K= 12 X= 5.15625
Y= 26.9425841467 Z=
 -6 27781790538 I= 26.9740834291
K= 13 X= 5.625
Y= 32.2537899246 Z=
 -8 71049106261 I= 30.9599218494
K= 14 X= 6.09375
Y= 37.6954972602 Z=
 -11 0632559384 I= 34.2441653158
K= 15 X= 6.5625
Y= 41.9998399394 Z=
 -13 0971226644 I= 37.2932371273
K= 16 X= 7.03125
Y= 45.9179565876 Z=
 -14 8351902234 I= 40.1364358381
K= 17 X= 7.5
Y= 49.9476548404 Z=
 -15 9966980475 I= 42.4509350147
-----

```

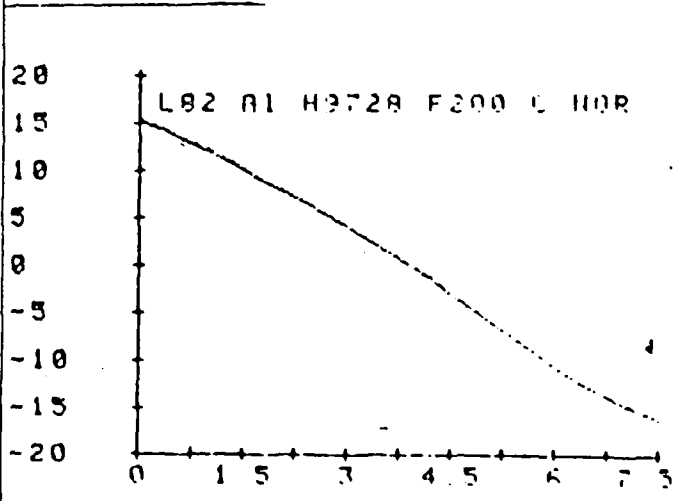
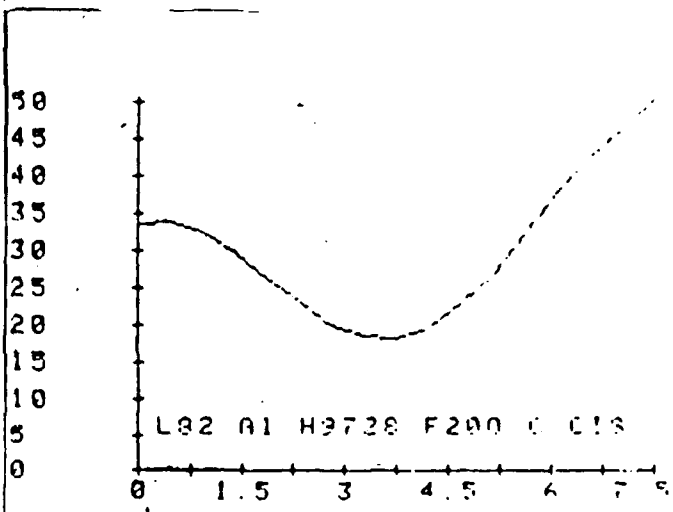

FIN DES CALCULS
end of calculations

SANCEF - BACON : Version 1.3-9

21-HOU-06 16:13:17

INTEGRATION ELEMENTS - CHIEF ENGINEERS

INTEGRATION ELEMENTS - CHIEF ENGINEERS

3029	29
3028	28
3027	27
3026	26
3025	25
3024	24
3023	23

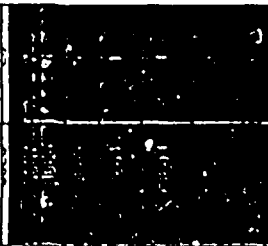

2079	2129	2129
2078	2128	2128
2077	2127	2127
2076	2126	2126
2075	2125	2125
2074	2124	2124
2073	2123	2123

INTEGRATION ELEMENTS - CHIEF ENGINEERS

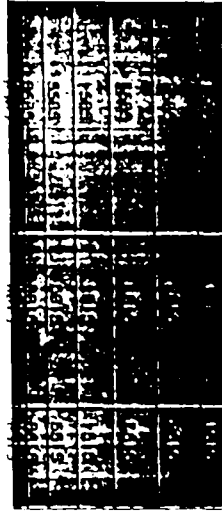

INTEGRATION ELEMENTS - CHIEF ENGINEERS



SAMCEF - BACON : Version 1.3-9 21-11-01 14:21:52

622	672	722	772	822	872	922	972	1022	1072	1122	1172	1222
826	876	926	976	1026	1076	1126	1176	1226	1276	1326	1376	1426

ADMESIF : MYSOL 9628

611	661	711	761	811	861	911	961	1011	1061	1111	1161	1211
612	662	712	762	812	862	912	962	1012	1062	1112	1162	1212
613	663	713	763	813	863	913	963	1013	1063	1113	1163	1213
614	664	714	764	814	864	914	964	1014	1064	1114	1164	1214
615	665	715	765	815	865	915	965	1015	1065	1115	1165	1215
616	666	716	766	816	866	916	966	1016	1066	1116	1166	1216
617	667	717	767	817	867	917	967	1017	1067	1117	1167	1217
618	668	718	768	818	868	918	968	1018	1068	1118	1168	1218
619	669	719	769	819	869	919	969	1019	1069	1119	1169	1219
620	670	720	770	820	870	920	970	1020	1070	1120	1170	1220

SUPPORT INTERNE : A-1001

NUMEROTATION ELEMENTS

SAMCEF - BACON : Version 1.3-9

18-DEC-86 13:13:14

VALUE 4 mm
Value

254

226

197

167

141

113

85

56

26

9

displacement along x

Displacement's modulo 32000

VALUE 5 mm
Value

15

13

22

48

52

77

75

113

132

150

167

Displacement's modulo 32000

SAMCEF - BACON : Version 1.3-9

12-DEC-86 13:44:59

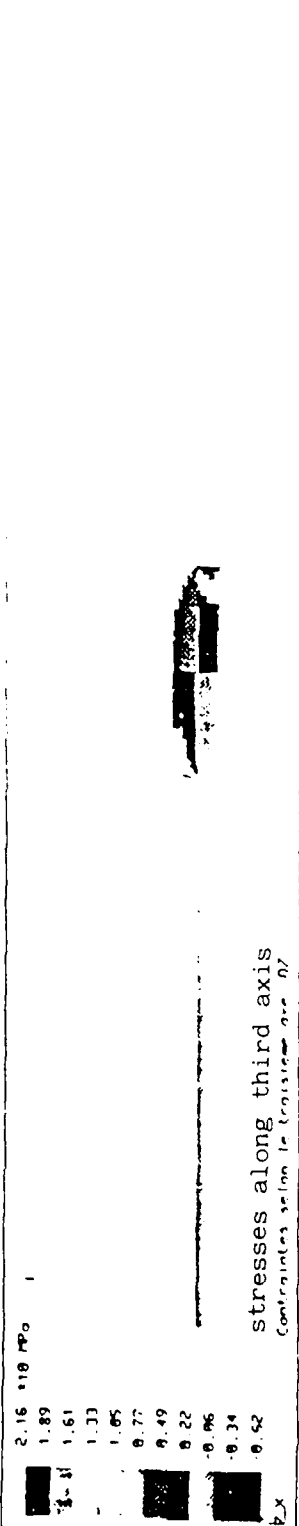
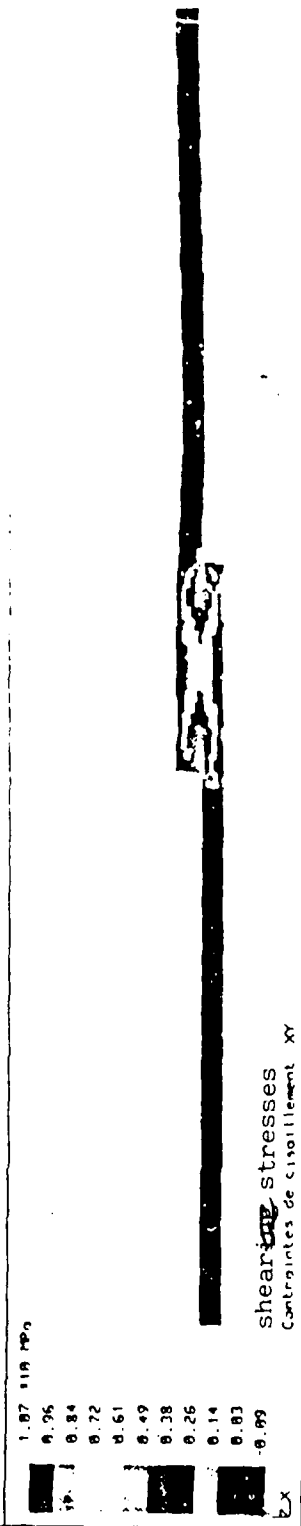
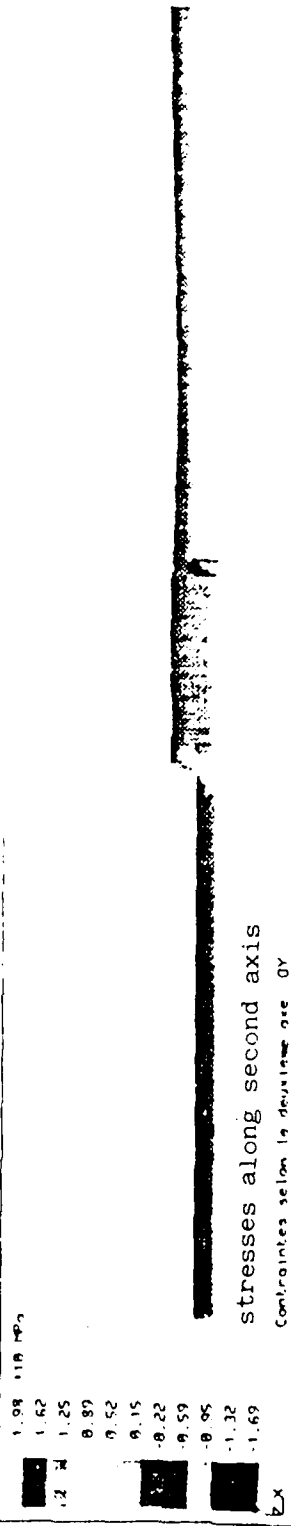
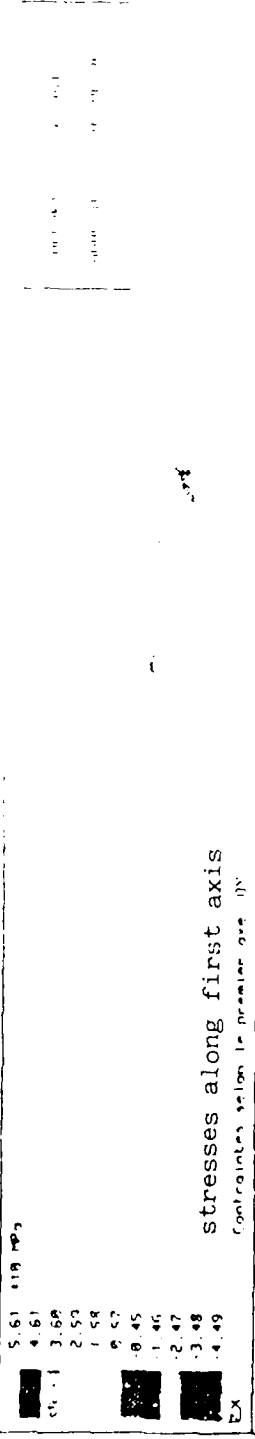

SAMCEF - BACON : Version 1.3-g

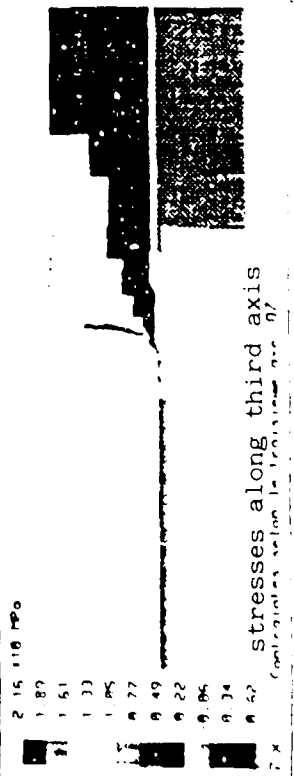
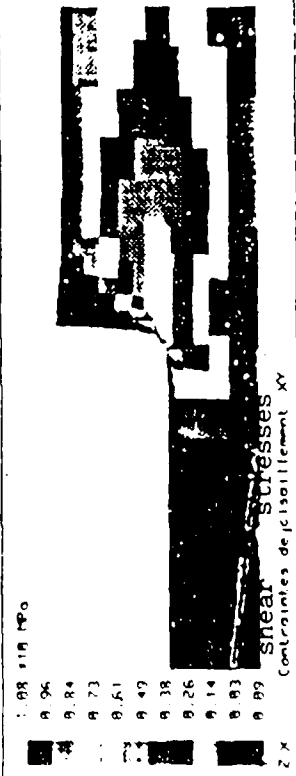
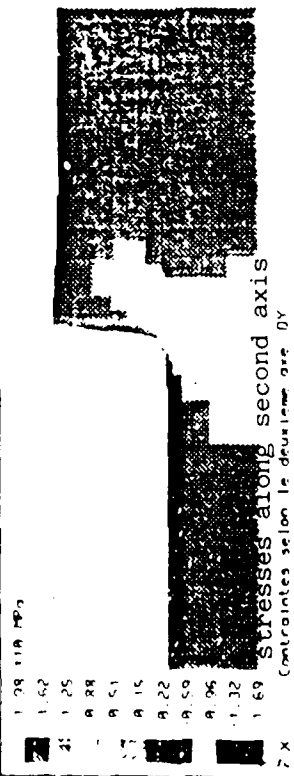
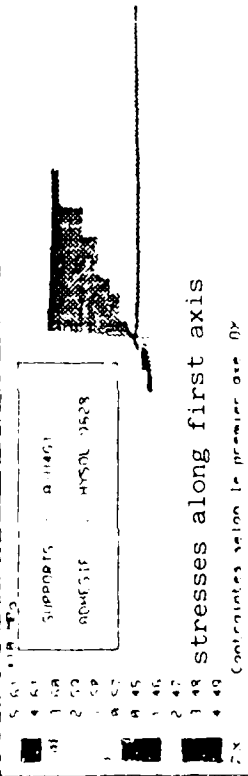

13-DEC-86 13:44:59

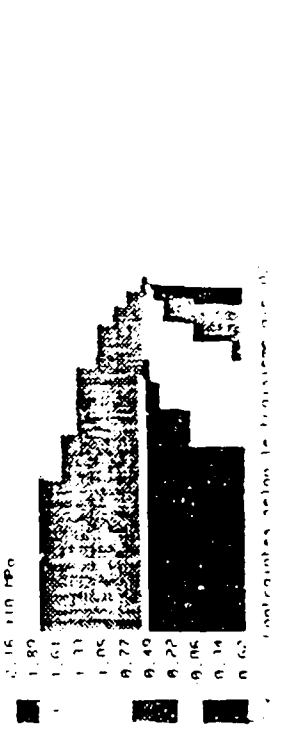
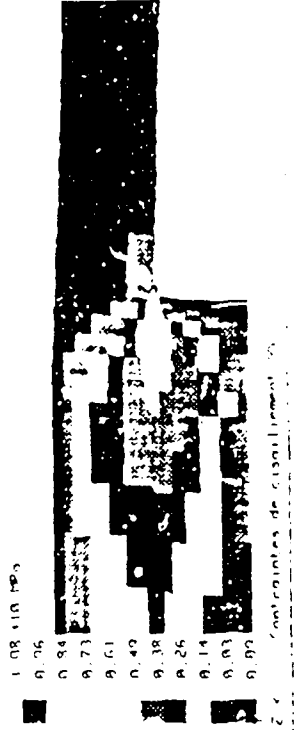
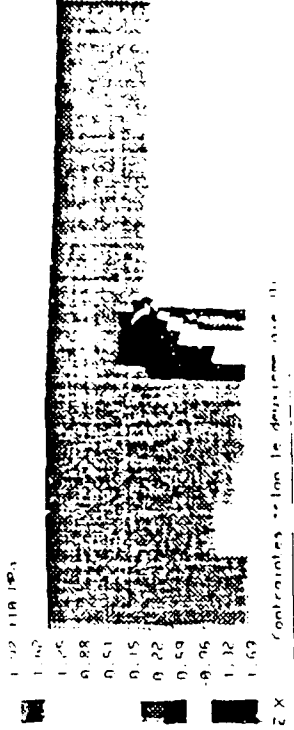
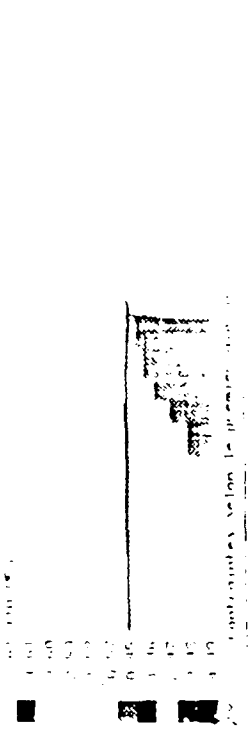

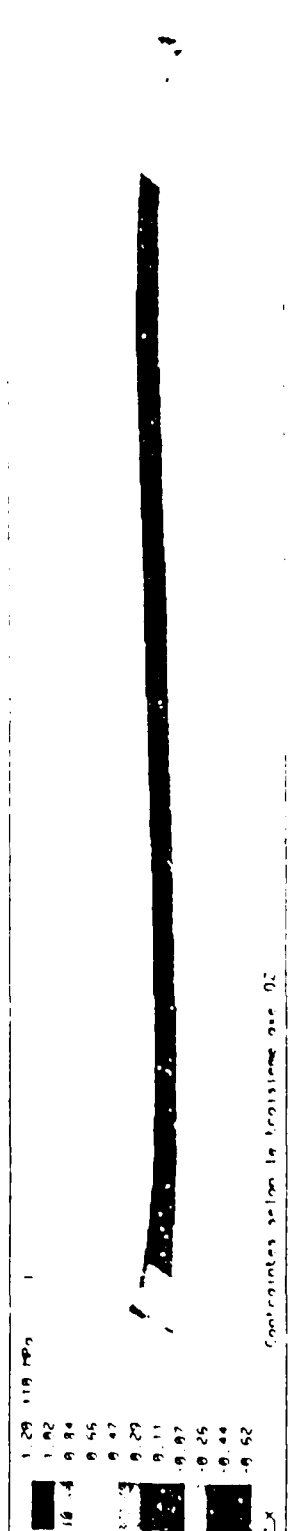
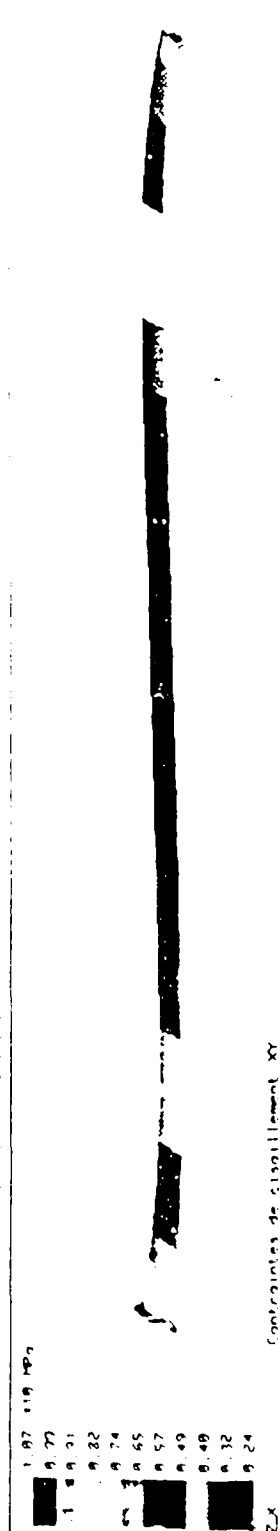

SAMCEF - BACON : Version 1.3-9

19-DEC-86 02:06:00

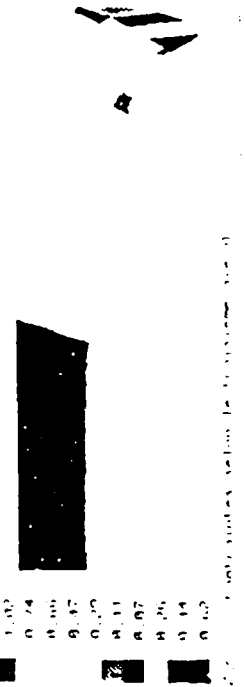
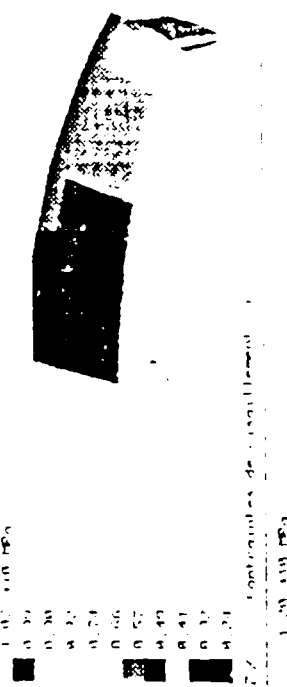
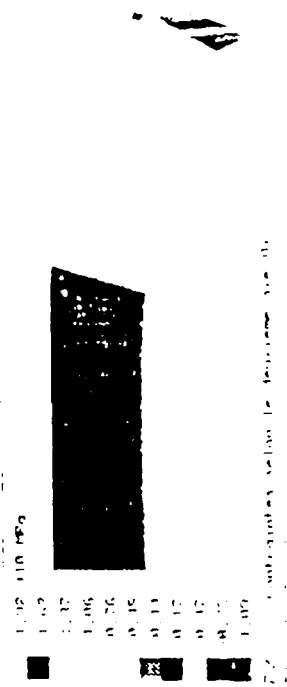
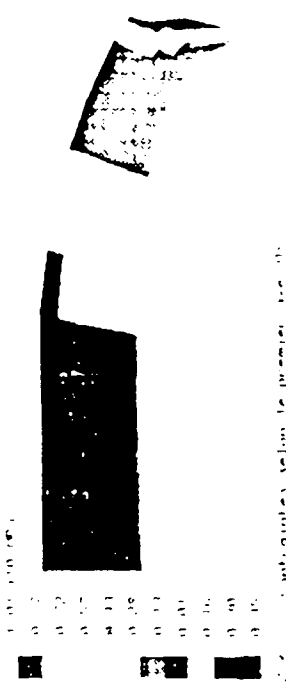
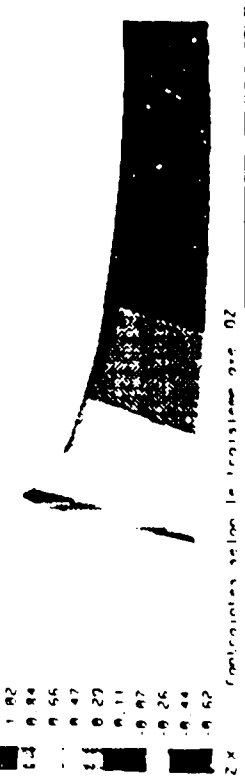
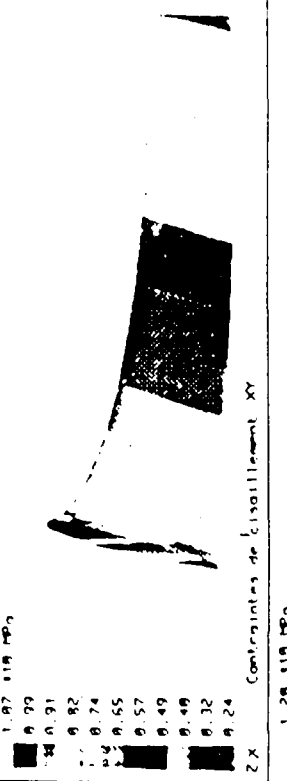
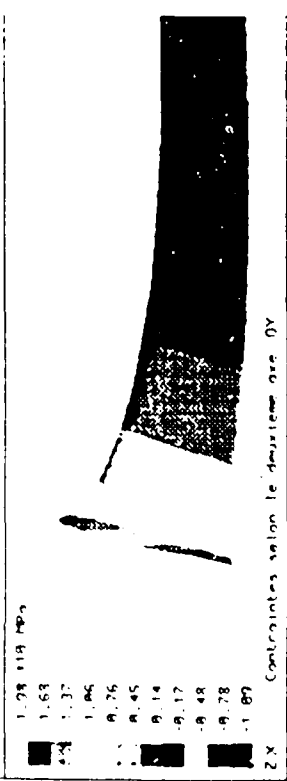
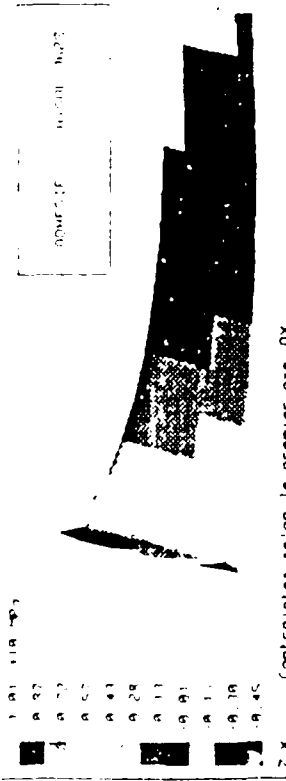

REPORT DOCUMENTATION PAGE

(Notes on completion overleaf)

Overall security classification of sheet UNCLASSIFIED

(As far as possible this sheet should contain only unclassified information. If it is necessary to enter classified information, the box concerned must be marked to indicate the classification eg (R), (C), or (S)).

1. DRIC Reference (if known)	2. Originator's Reference	3. Agency Reference DRIC-T- 8168	4. Report Security Classification Unlimited
5. Originator's Code (if known) 9999000N	6. Originator (Corporate Author) Name and Location SNIAS-NT-18926/AQET (France)		
5A. Sponsoring Agency's Code (if known) 7231000N	6A. Sponsoring Agency (Contract Authority) Name and Location Procurement Executive, Ministry of Defence, Defence Research Information Centre, UK.		
7. Title Design of Glued Joints, Elastoplastic Adhesives			
7A. Title in Foreign Language (in the case of translation) Calcul Des Assemblages Collés Adhésifs Elastoplastiques			
7B. Presented at (for conference papers). Title, place and date of conference			
8. Author 1, Surname, initials Maignet	9A Author 2 Martin	9B Authors 3, 4... et al	10. Date pp ref 11.1988 55
11. Contract number and Period		12. Project	13 & 14 Other References.
15. Distribution statement			
<p>Descriptors (or keywords)</p> <p>Bonded joints, Glued joints, Adhesives, Adhesive bonding, Adhesion tests, Epoxy resins, Computation, Computer program</p>			
<p>Abstract</p> <p>Experimental methods for defining the mechanical features of adhesives with elastoplastic properties and methods of calculation for analysing the behaviour of bonded joints are described. Tests of the properties of the adhesive HYSOL EA 9628 NW are described. Calculation methods using the final element method are developed and the programmes are prevented. This is on first part of a two-part investigation; in the second part further tests will be carried out and the software developed for non-linear calculation.</p> <p style="text-align: center;">DA</p>			

NOTES ON COMPLETION OF REPORT DOCUMENTATION PAGE

This Documentation Page is designed specifically for MOD reports and reports produced by Contractors.

Boxes marked* below need be completed only if the information is readily available.

- *1 DRIC reference: Enter DRIC reference (BR number) if one has been assigned.
- 2 Originator's Reference: Enter the report number by which the document is identified by the originator of the report, in the form in which it appears on the cover.
- 3 Agency reference: Enter reference number allocated by sponsoring agency (contract authority) in the case of contract reports.
- 4 Report Security Classification: Enter security classification or marking which limits the circulation of the report, or enter UNLIMITED when this applies.
- *5 Originator's Code: Code number for the DRIC-standardised form of the entry appearing in Box 6.
- *5A Sponsoring Agency's Code: Code number for the DRIC-standardised form of the entry appearing in Box 6A.
- 6 Originator (corporate author): Enter name and location of the organisation preparing the report.
- 6A Sponsoring Agency (Contract Authority): Enter the name of the monitoring MOD Branch or Establishment in the case of Contractor's reports. If an MOD report covers work funded by an outside agency, enter the name of that agency.
- 7 Title: Enter the complete report title in capital letters by omitting initial definite or indefinite articles. If the report covers a specific period, enter this after the title, eg (1.1.1972-31.3.1972).
- 7A Title in Foreign Language: In the case of translations, enter the foreign language title (transliterated if necessary) and the translated English title in Box 7.
- 7B Conference Papers: If 7 is the title of a paper presented at a Conference, or a Conference proceedings, enter the Conference Title, where it was held and the date.
- 8 Author 1: Enter the name of the first author, followed by initials.
- 9A Author 2: Enter the name of the second author, followed by initials.
- 9B Authors 3,4 ...: Enter third and following authors' names.
- 10 Date: Enter the month (in figures) and the year of the report (Dec., 1969 is written 12.1969). If the report is undated but a period covered by the report is indicated, enter the date at the end of the period. pp.ref. Enter the inclusive number of pages in the report containing information, i.e. including appendices, tables and illustrations, and the total number of references cited.
- 11 Contract number: Enter the number of the contract or grant under which the report was written. Period: (Always associated with the Contract Number). Only to be used for reports covering a specific period, e.g. quarterly, annual or final reports. Enter QR-1, AR, FR, as appropriate.
- 12. Project: Enter project name or number.
- 13 & 14 Other Reference: Enter any reference, other than those in Boxes 2 or 3, by which the report may be identified.
- 15. Distribution statement. Enter any limitations on the distribution of the document. If distribution is limited to particular groups eg MOD, MOD and its Contractors, etc. it should be stated. If the distribution is the responsibility of another authority eg a HQ Directorate (Technical Policy Authority) enter "Distribution controlled by MOD Technical Policy Authority". Enter "via DRIC" after "Authority" where appropriate and name the Technical Policy Authority if possible.

Descriptors: Any number of descriptors (or key-words) can be entered. If selected from a published thesaurus, eg The Thesaurus of Engineering and Scientific Terms (TEST), this should be indicated.

Abstract: The abstract should preferably not exceed 150 words, i.e. it can be considerably shorter than the Abstract to be provided on the Title Page of the Report. Information available in the report title need not be included in the abstract.