

NAVAL POSTGRADUATE SCHOOL

Monterey, California

AD-A227 091



DTIC
ELECTE
OCT 03 1990
S B D
Co

THESIS

AUTOMATIC CONTROL OF STRAIGHTLINE MOTIONS
OF
TOWED VESSELS

by

John B. Newell

March, 1990

Thesis Advisor:

F. A. Papoulias

Approved for public release; distribution unlimited.

UNCLASSIFIED

SECURITY CLASSIFICATION OF THIS PAGE

REPORT DOCUMENTATION PAGE

1a. REPORT SECURITY CLASSIFICATION UNCLASSIFIED		1b. RESTRICTIVE MARKINGS	
2a. SECURITY CLASSIFICATION AUTHORITY		3. DISTRIBUTION/AVAILABILITY OF REPORT Approved for public release; distribution is unlimited.	
2b. DECLASSIFICATION/DOWNGRADING SCHEDULE			
4. PERFORMING ORGANIZATION REPORT NUMBER(S)		5. MONITORING ORGANIZATION REPORT NUMBER(S)	
6a. NAME OF PERFORMING ORGANIZATION Naval Postgraduate School	6b. OFFICE SYMBOL (If applicable) 52	7a. NAME OF MONITORING ORGANIZATION Naval Postgraduate School	
6c. ADDRESS (City, State, and ZIP Code) Monterey, CA 93943-5000		7b. ADDRESS (City, State, and ZIP Code) Monterey, CA 93943-5000	
8a. NAME OF FUNDING/SPONSORING ORGANIZATION	8b. OFFICE SYMBOL (If applicable)	9. PROCUREMENT INSTRUMENT IDENTIFICATION NUMBER	
8c. ADDRESS (City, State, and ZIP Code)		10. SOURCE OF FUNDING NUMBERS	
		Program Element No.	Project No.
		Task No.	Work Unit Accession Number
11. TITLE (Include Security Classification) AUTOMATIC CONTROL OF STRAIGHTLINE MOTIONS OF TOWED VESSELS			
12. PERSONAL AUTHOR(S) Newell, John Baker			
13a. TYPE OF REPORT MASTER'S THESIS	13b. TIME COVERED From To	14. DATE OF REPORT (year, month, day) 1990, MARCH, 29	15. PAGE COUNT 78
16. SUPPLEMENTARY NOTATION The views expressed in this thesis are those of the author and do not reflect the official policy or position of the Department of Defense or the U.S. Government.			
17. COSATI CODES		18. SUBJECT TERMS (continue on reverse if necessary and identify by block number)	
FIELD	GROUP	TOWING, CONTROL, STABILITY, AUTOMATIC CONTROL SYSTEM	
	SUBGROUP		
19. ABSTRACT (continue on reverse if necessary and identify by block number) A classical control system with a full-order observer is designed to stabilize the motions of towed vessels. The control method is transverse movement of the towline attachment point on the towed vessel. The linearized sway and yaw equations of motions are developed, leading to the control system design. The control system is tested using Matrixx. Results for a barge, a mariner-class ship and a tanker are presented. Possible benefits of the implementation of such a system include improved fuel economy, a wider range of environmental conditions during which towing operations can be conducted, and improved safety.			
20. DISTRIBUTION/AVAILABILITY OF ABSTRACT <input checked="" type="checkbox"/> UNCLASSIFIED/UNLIMITED <input type="checkbox"/> SAME AS REPORT <input type="checkbox"/> DTIC USERS		21. ABSTRACT SECURITY CLASSIFICATION UNCLASSIFIED	
22a. NAME OF RESPONSIBLE INDIVIDUAL Fotis A. Papoulias		22b. TELEPHONE (Include Area code) (408) 646-3381	22c. OFFICE SYMBOL Code 69PA

DD FORM 1473, 84 MAR

83 APR edition may be used until exhausted
All other editions are obsolete

SECURITY CLASSIFICATION OF THIS PAGE
UNCLASSIFIED

Approved for public release; distribution is unlimited.

Automatic Control of Straightline Motions
of
Towed Vessels

by

John B. Newell
Lieutenant, United States Navy
B.S., United States Naval Academy

Submitted in partial fulfillment
of the requirements for the degree of

MASTER OF SCIENCE IN MECHANICAL ENGINEERING

from the

NAVAL POSTGRADUATE SCHOOL
March, 1990

Author:

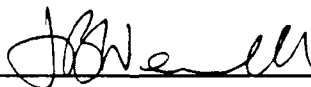

John B. Newell

Approved by:

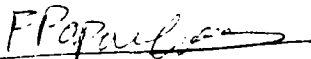

F. A. Papoulias, Thesis Advisor

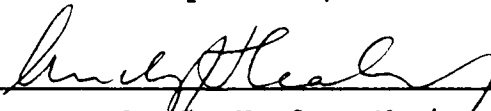

A. J. Healy, Chairman,
Department of Mechanical Engineering

ABSTRACT

A classical control system with a full-order observer is designed to stabilize the motions of towed vessels. The control method is transverse movement of the towline attachment point on the towed vessel. The linearized sway and yaw equations of motion are developed, leading to the control system design. The control system is tested using MATRIX_x. Results for a barge, a mariner-class ship and a tanker are presented. Possible benefits of the implementation of such a system include improved fuel economy, a wider range of environmental conditions during which towing operations can be conducted, and improved safety.

Keywords: Vicos, ...

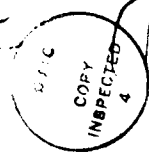

Accession For	
NTIS GRA&I	<input checked="" type="checkbox"/>
DTIC TAB	<input type="checkbox"/>
Unannounced	<input type="checkbox"/>
Justification _____	
By _____	
Distribution/ _____	
Availability Codes	
Dist	Avail and/or Special
A-1	

TABLE OF CONTENTS

I.	INTRODUCTION.....	1
II.	PROBLEM DEVELOPMENT.....	3
	A. EQUATIONS OF MOTION.....	3
	B. DEVELOPMENT OF THE 2-DIMENSIONAL TOWING STATE EQUATIONS.....	8
	C. CONTROLLER DESIGN.....	14
	D. OBSERVER DESIGN.....	15
	E. MATRIX IMPLEMENTATION.....	20
III.	RESULTS.....	21
	A. MARINER.....	22
	B. BARGE.....	27
	C. TANKER.....	34
IV.	CONCLUSIONS AND RECOMMENDATIONS.....	47
	A. CONCLUSIONS.....	47
	B. RECOMMENDATIONS.....	48
	APPENDIX.....	51
	LIST OF REFERENCES.....	70
	INITIAL DISTRIBUTION LIST.....	71

LIST OF FIGURES

No.	Title	Page
1	Coordinate Systems	4
2	Problem Geometry	9
3	Plant Block Diagram	13
4	Observer Block Diagram	18
5	Plant/Compensator Block Diagram	19
6	Matrixx Plant/Compensator Block Diagram	23
7	Mariner With Observer/Without Control	24
8	Matrixx Plant/Controller Block Diagram	25
9	Mariner Without Observer/With Control	26
10	Mariner With Observer/With Control	28
11	Barge With Observer/Without Control	29
12	Barge Without Observer/With Control	31
13	Barge With Observer/With Control	32
14	Barge With Observer/With Control (<0.0045)	33
15	Tanker With Observer/Without Control	35
16	Tanker Without Observer/With Control	36
17	Tanker With Observer/With Control	37
18	Tanker With Observer/With Control (<0.05)	39
19	Tanker With Observer/With Control (<0.035)	40
20	Tanker Robustness Test With Observer	41
21	Tanker Robustness Test Without Observer	43
22	Tanker Without Observer/With Mod. Cont.	44
23	Tanker Without Observer/With Mod. Cont. (<0.035)	45
24	Matrixx Plant/Compensator Block Diagram	52
25	Matrixx Plant/Controller Block Diagram	53
26	Matrixx Plant (1 of 3) Block Diagram	54
27	Matrixx Plant (2 of 3) Block Diagram	55
28	Matrixx Plant (3 of 3) Block Diagram	56
29	Matrixx Observer (1 of 5) Block Diagram	57
30	Matrixx Observer (2 of 5) Block Diagram	58
31	Matrixx Observer (3 of 5) Block Diagram	59
32	Matrixx Observer (4 of 5) Block Diagram	60
33	Matrixx Observer (5 of 5) Block Diagram	61
34	Matrixx Controller Block Diagram	62
35	Matrixx Program Listing With Observer	63
36	Matrixx Program Listing Without Observer	66

LIST OF TABLES

<u>No.</u>	<u>Title</u>	<u>Page</u>
1	TOWED VESSEL DATA	68
2	NONDIMENSIONAL TERMS	69

I. INTRODUCTION

Towing operations sometimes result in loss of property and/or life, owing to the inherently dangerous nature of the towing operation. The instability of the tow can lead to uncontrolled motion of the towed and towing vessels. Much research has been performed concerning towed vessel stability, and stable configurations of the towline attachment point, towline length, towline tension and other important parameters [Ref. 1,2, and 3].

This paper investigates active towing control, as can be provided by a classical control system. Athwartship motion of the towline attachment point on the towed vessel can provide some measure of control over the motions of the tow. A small initial offset from the path is the "disturbance". Since this analysis involves linearization of the equations of motion, and uses only proportional control, response to a constant or time-variant disturbance such as wind, wave or current action, was not studied. Further studies utilizing the nonlinear equations of motion and/or proportional-integral control, would provide assistance in determining the feasibility of the installation of such a system. Possible benefits of the implementation of such a system

include improved safety, increased efficiency, and a wider range of environmental conditions during which towing operations can take place.

An initial discussion of the development of the sway and yaw equations of motion is pursued, and then these equations are applied to the towing situation. The controller design is explained, and since all state variables cannot be measured, a full-order observer is designed. Finally, the system is implemented analytically using Matrix_x.

Matrix_x provides the tools necessary for investigating the response of the single-input single-output (SISO) system developed in this study. The ability to implement the control system graphically, in block diagram form, allows the user to more easily and understandably make alterations to the control system. The on-line graphics capabilities of Matrix_x allow almost immediate feedback concerning the performance.

II. PROBLEM DEVELOPMENT

A. EQUATIONS OF MOTION

The equations of motion will be developed using two coordinate systems. The origin of the first is fixed in space, while the origin of the second is at the center of gravity of the towed vessel. In general, the vessel has six degrees of freedom of motion:

- * surge along the x_g -axis
- * roll about the x_g -axis
- * sway along the y_g -axis
- * pitching about the y_g -axis
- * heave along the z_g -axis
- * yaw about the z_g -axis

This paper addresses only motions in the horizontal plane, and assumes a constant surge velocity component, u . Other assumptions include:

- * no towed vessel/towing vessel interaction
- * massless, inextensible towline
- * small motions about the initial conditions
- * no control time-lag

Therefore, only the sway and yaw equations of motion will be developed. Using Figure 1, it can be shown that

$$\Sigma X_g = \Sigma X_f \cos\psi + \Sigma Y_f \sin\psi \quad \text{and} \quad (1A)$$

$$\Sigma Y_g = -\Sigma X_f \sin\psi + \Sigma Y_f \cos\psi, \quad (1B)$$

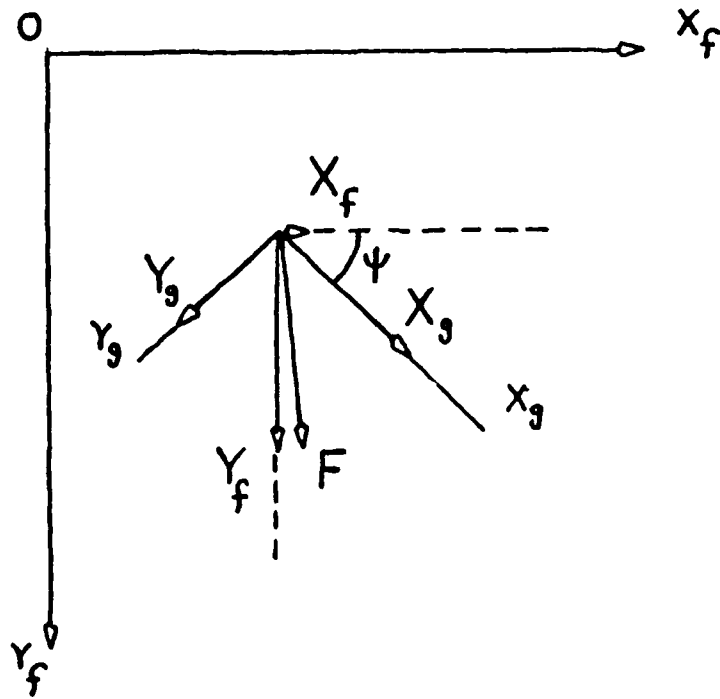

Figure 1. Coordinate Systems

$$\Sigma N_g = I_z \ddot{\psi} = \Sigma N_f \quad (1C)$$

where X_g are forces in the x_g direction and Y_g are forces in the y_g direction. Expressions for X_f and Y_f must be found. N_g are the moments about the center of gravity.

If a similar velocity diagram is drawn, it can be shown that

$$\dot{x}_f = u \cos \psi - v \sin \psi \quad \text{and}$$

$$\dot{y}_f = u \sin \psi + v \cos \psi.$$

Differentiating with respect to time yields

$$\ddot{x}_f = -u \dot{\psi} \sin \psi + \dot{u} \cos \psi - \dot{\psi} v \cos \psi - \dot{v} \sin \psi \quad \text{and}$$

$$\ddot{y}_f = \dot{\psi} u \cos \psi + \dot{u} \sin \psi - \dot{\psi} v \sin \psi + \dot{v} \cos \psi.$$

Or, after collecting like terms,

$$\ddot{x}_f = \dot{u} \cos \psi - \dot{v} \sin \psi - \dot{\psi} (u \sin \psi + v \cos \psi) \quad \text{and} \quad (2A)$$

$$\ddot{y}_f = \dot{u} \sin \psi + \dot{v} \cos \psi + \dot{\psi} (u \cos \psi - v \sin \psi). \quad (2B)$$

From Newton's laws of motion it is apparent that

$$\Sigma X_f = m \ddot{x}_f \quad \text{and} \quad (3A)$$

$$\Sigma Y_f = m \ddot{y}_f. \quad (3B)$$

Substituting equations (2A) and (2B) into equations (3A) and (3B) yields the desired expressions for ΣX_f and ΣY_f .

Combining these with equations (1A) and (1B) gives

$$\begin{aligned} \Sigma X_g &= m(\dot{u} \cos \psi - \dot{v} \sin \psi - \dot{\psi} (u \sin \psi + v \cos \psi)) \cos \psi \\ &\quad + m(\dot{u} \sin \psi + \dot{v} \cos \psi + \dot{\psi} (u \cos \psi - v \sin \psi)) \sin \psi \\ &= m((\dot{u} \cos^2 \psi - \dot{\psi} v \cos^2 \psi) + (\dot{u} \sin^2 \psi - \dot{\psi} v \sin^2 \psi)) \\ \Sigma X_g &= m[\dot{u} - v \dot{\psi}]. \end{aligned} \quad (4A)$$

Likewise,

$$\begin{aligned}\Sigma Y_g &= -m(\dot{u}\cos\psi - \dot{v}\sin\psi - \dot{\psi}(u\sin\psi + v\cos\psi))\sin\psi \\ &\quad + m(\dot{u}\sin\psi + \dot{v}\cos\psi + \dot{\psi}(u\cos\psi - v\sin\psi))\cos\psi \\ &= m(\dot{v}\sin^2\psi + \dot{\psi}u\sin^2\psi + \dot{v}\cos^2\psi + \dot{\psi}u\cos^2\psi)\end{aligned}$$

$$\Sigma Y_g = m[\dot{v} + \dot{\psi}u]. \quad (4B)$$

From equation (1C),

$$\Sigma N_g = I_z \ddot{\psi} \quad (4C)$$

Equations (4A), (4B), and (4C) give the forces acting on the center of gravity of the towed vessel in terms of the motion of the center of gravity. The forces implicitly stated in X_g , Y_g , and N_g are not explicitly stated on the right hand side of the equations. Forces such as towline force, propellor thrust, drag, and rudder do not appear, but are implicit in X , Y , and N . (For simplicity, X_g , Y_g , and N_g will be denoted as X , Y , and N throughout the remainder of the paper.) Many of these forces are nonlinear, but by expanding force terms using a Taylor series and keeping just the linear terms, expressions for small deviations from the initial states can be written. It is assumed that the force terms X , Y , and N are functions of the velocities and accelerations u , v , \dot{u} , \dot{v} , $\dot{\psi}$, and $\ddot{\psi}$. Then,

$$\begin{aligned}Y &= (\partial Y/\partial u)_0 \Delta u + (\partial Y/\partial v)_0 \Delta v + (\partial Y/\partial \dot{u})_0 \Delta \dot{u} + (\partial Y/\partial \dot{v})_0 \Delta \dot{v} \\ &\quad + (\partial Y/\partial \dot{\psi})_0 \Delta \dot{\psi} + (\partial Y/\partial \ddot{\psi})_0 \Delta \ddot{\psi} + Y_0\end{aligned}$$

From symmetry of the towed vessel about its longitudinal axis it is apparent that,

$$(\partial Y/\partial u)_0 = (\partial Y/\partial \dot{u})_0 = 0.$$

So,

$$Y = (\partial Y/\partial v)_{\circ} \Delta v + (\partial Y/\partial \dot{v})_{\circ} \Delta \dot{v} + (\partial Y/\partial \dot{\psi})_{\circ} \Delta \dot{\psi} + (\partial Y/\partial \ddot{\psi})_{\circ} \Delta \ddot{\psi} + Y_{\circ}. \quad (5A)$$

To obtain an equivalent expression for Y , substitute the perturbed values into the right hand side of equation (4B).

$$Y = m[(\dot{v}_{\circ} + \Delta \dot{v}) + (\dot{\psi}_{\circ} + \Delta \dot{\psi})(u_{\circ} + \Delta u)] \\ = [\dot{v}_{\circ} + \Delta \dot{v} + \dot{\psi}_{\circ} u_{\circ} + \dot{\psi}_{\circ} \Delta u + \Delta \dot{\psi} u_{\circ} + \Delta \dot{\psi} \Delta u]m.$$

Dropping the higher order terms yields,

$$Y = m[v_{\circ} + \dot{\psi}_{\circ} u_{\circ} + \Delta \dot{v} + \dot{\psi}_{\circ} \Delta u + \Delta \dot{\psi} u_{\circ}]. \quad (5B)$$

After noting that the first two terms in equation (5B) are Y_{\circ} , equations (5A) and (5B) can be equated to show that

$$(\partial Y/\partial v)_{\circ} \Delta v + (\partial Y/\partial \dot{v})_{\circ} \Delta \dot{v} + (\partial Y/\partial \dot{\psi})_{\circ} \Delta \dot{\psi} + (\partial Y/\partial \ddot{\psi})_{\circ} \Delta \ddot{\psi} = \\ m[\Delta \dot{v} + \dot{\psi}_{\circ} \Delta u + \Delta \dot{\psi} u_{\circ}].$$

Adopting the notation $(\partial Y/\partial v)_{\circ} = Y_v$, $(\partial Y/\partial \dot{v})_{\circ} = Y_{\dot{v}}$, $(\partial Y/\partial \dot{\psi})_{\circ} = Y_{\dot{\psi}}$, $(\partial Y/\partial \ddot{\psi})_{\circ} = Y_{\ddot{\psi}}$, $\Delta v = v$, $\Delta \dot{v} = \dot{v}$, $\Delta \dot{\psi} = \dot{\psi}$, and $\Delta \ddot{\psi} = \ddot{\psi}$, and assuming $v_{\circ} = \dot{u}_{\circ} = \dot{v}_{\circ} = \dot{\psi}_{\circ} = \ddot{\psi}_{\circ} = 0$, this equation can be rewritten as

$$Y_v v + Y_{\dot{v}} \dot{v} + Y_{\dot{\psi}} \dot{\psi} + Y_{\ddot{\psi}} \ddot{\psi} = m[\dot{v} + \dot{\psi} u_{\circ}]. \quad (6A)$$

It must be remembered that v , \dot{v} , $\dot{\psi}$, and $\ddot{\psi}$ denote small deviations from the initial state. Likewise, an equation for the yaw forces can be developed yielding,

$$N_v v + N_{\dot{v}} \dot{v} + N_{\dot{\psi}} \dot{\psi} + N_{\ddot{\psi}} \ddot{\psi} = I_z \ddot{\psi}. \quad (6B)$$

Equations (6A) and (6B) can be rewritten as

$$Y_v v + (Y_{\dot{v}} - m)\dot{v} + (Y_{\dot{\psi}} - m u_{\circ})\dot{\psi} + Y_{\ddot{\psi}} \ddot{\psi} - F_a = 0 \quad (7A)$$

$$N_v v + N_{\dot{v}} \dot{v} + N_{\dot{\psi}} \dot{\psi} + (N_{\ddot{\psi}} - I_z)\ddot{\psi} - M_a = 0, \quad (7B)$$

where F_a are applied forces and M_a are applied moments.

B. DEVELOPMENT OF THE 2-DIMENSIONAL TOWING STATE EQUATIONS

For the situation depicted in Figure 2, equations (7A) and (7B) can be written as

$$Y_v \dot{v} + (Y_{\dot{v}} - m) \ddot{v} + (Y_{\dot{\psi}} - mu_0) \dot{\psi} + Y_{\ddot{\psi}} \ddot{\psi} - T \sin(\gamma + \psi) = 0 \quad (8A)$$

$$N_v \dot{v} + N_{\dot{v}} \ddot{v} + N_{\dot{\psi}} \dot{\psi} + (N_{\ddot{\psi}} - I_z) \ddot{\psi} - Tx_p \sin(\gamma + \psi) - Ty_p \cos(\gamma + \psi) = 0 \quad (8B)$$

Motion of the towed vessel will be controlled by varying y_p . The terms involving the towline tension, T , are nonlinear and must be linearized as follows before proceeding further. For small angles γ and ψ ,

$$\begin{aligned} \sin \gamma &= \gamma = OP/L = (y + x_p \psi + y_p)/L \quad \text{and} \\ \sin(\gamma + \psi) &= \gamma + \psi = (y + x_p \psi + y_p)/L + \psi \\ &= \psi(1 + x_p/L) + y/L + y_p/L. \end{aligned}$$

Also,

$$\begin{aligned} \dot{y} &= v + u_0 \sin \psi \approx v + u_0 \psi \quad \text{and} \\ v &= \dot{y} - u_0 \psi \quad \text{so, } \dot{v} = \ddot{y} - d(u_0 \psi)/dt = \ddot{y} - u_0 \dot{\psi}. \end{aligned}$$

Substituting these expressions into equations (8A) and (8B) yields,

$$(Y_{\dot{v}} - m) \ddot{y} + Y_v \dot{y} - Ty/L + Y_{\ddot{\psi}} \ddot{\psi} - (Y_{\dot{v}} u - Y_{\dot{\psi}}) \dot{\psi} - [Y_v u + T(1 + x_p/L)] \psi = Ty_p/L \quad \text{and} \quad (9A)$$

$$\begin{aligned} N_v \ddot{y} + N_v \dot{y} - Tx_p y/L + (N_{\ddot{\psi}} - I_z) \ddot{\psi} - (N_{\dot{v}} u - N_{\dot{\psi}}) \dot{\psi} \\ - [N_v u + Tx_p(1 + x_p/L)] \psi = Tx_p y_p/L + Ty_p. \end{aligned} \quad (9B)$$

Then, by assigning the state variables

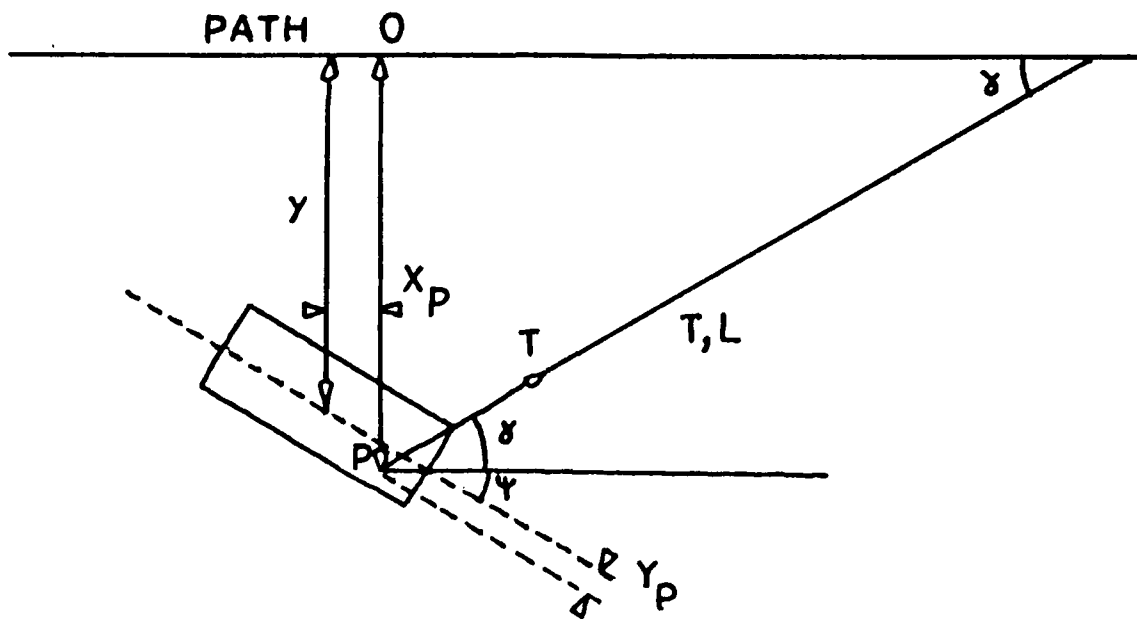

Figure 2. Problem Geometry

$$X_1 = y, X_2 = \psi, X_3 = \dot{y}, \text{ and } X_4 = \dot{\psi},$$

and substituting into equations (9A) and (9B)

$$(Y_{\dot{v}} - m)\dot{X}_3 + Y_{\dot{\psi}}\dot{X}_4 = -Y_v X_3 + TX_1/L + (Y_{\dot{v}}u - Y_{\dot{\psi}})X_4 + [Y_v u + T(1 + x_p/L)]X_2 + Ty_p/L \quad (10A)$$

$$N_{\dot{v}}\dot{X}_3 + (N_{\dot{\psi}} - I_z)\dot{X}_4 = -N_v X_3 + Tx_p X_1/L + (N_{\dot{v}}u - N_{\dot{\psi}})X_4 + [N_v u + Tx_p(1 + x_p/L)]X_2 + Tx_p y_p/L + Ty_p \quad (10B)$$

From the original equations defining the state variables, it can be seen that

$$\dot{X}_1 = X_3 \text{ and} \quad (11A)$$

$$\dot{X}_2 = X_4. \quad (11B)$$

These comprise the first two of four state equations. The second two state equations must be found from equations (10A) and (10B). Multiplying equation (10A) by $(N_{\dot{\psi}} - I_z)$ and equation (10B) by $(-Y_{\dot{\psi}})$ and adding yields an equation for \dot{X}_3 .

$$\begin{aligned} & [(N_{\dot{\psi}} - I_z)(Y_{\dot{v}} - m) - N_{\dot{v}}Y_{\dot{\psi}}]\dot{X}_3 = \\ & T/L[(N_{\dot{\psi}} - I_z) - x_p Y_{\dot{\psi}}]X_1 + \\ & \{ [Y_v u + T(1 + x_p/L)](N_{\dot{\psi}} - I_z) - Y_{\dot{\psi}}[N_v u + Tx_p(1 + x_p/L)] \} X_2 \\ & + [N_v Y_{\dot{\psi}} - Y_v(N_{\dot{\psi}} - I_z)]X_3 \\ & + [(Y_{\dot{v}}u - Y_{\dot{\psi}})(N_{\dot{\psi}} - I_z) - Y_{\dot{\psi}}(N_{\dot{v}}u - N_{\dot{\psi}})]X_4 \\ & + T[(N_{\dot{\psi}} - I_z)/L - Y_{\dot{\psi}}(1 + x_p/L)]y_p. \end{aligned} \quad (11C)$$

Similarly, multiplying equation (10A) by $(-N_{\dot{v}})$ and equation (10B) by $(Y_{\dot{v}} - m)$ and adding yields an expression for \dot{X}_4 .

$$\begin{aligned}
& [(N_{\dot{\psi}} - I_z)(Y_{\dot{v}} - m) - N_{\dot{v}}Y_{\dot{\psi}}]\dot{X}_4 = \\
& T/L[x_p(Y_{\dot{v}} - m) - N_{\dot{v}}]X_1 + \\
& \{(Y_{\dot{v}} - m)[N_v u + Tx_p(1 + x_p/L)] - N_{\dot{v}}[Y_v u + T(1 + x_p/L)]\}X_2 \\
& + [N_{\dot{v}}Y_v - N_v(Y_{\dot{v}} - m)]X_3 \\
& + (-N_{\dot{v}}\mu - N_{\dot{\psi}}Y_{\dot{v}} + N_{\dot{\psi}}m + N_{\dot{v}}Y_{\dot{\psi}})X_4 \\
& + T[(Y_{\dot{v}} - m)(1 + x_p/L) - N_{\dot{v}}/L]y_p \tag{11D}
\end{aligned}$$

Equations (11A), (11B), (11C) and (11D) can be more conveniently expressed in the matrix form

$$\dot{\{X\}} = [A]\{X\} + [B]y_p. \tag{12}$$

$$\begin{bmatrix} \dot{X}_1 \\ \dot{X}_2 \\ \dot{X}_3 \\ \dot{X}_4 \end{bmatrix} = \begin{bmatrix} 0 & 0 & 1 & 0 \\ 0 & 0 & 0 & 1 \\ a_{31} & a_{32} & a_{33} & a_{34} \\ a_{41} & a_{42} & a_{43} & a_{44} \end{bmatrix} \begin{bmatrix} X_1 \\ X_2 \\ X_3 \\ X_4 \end{bmatrix} + \begin{bmatrix} 0 \\ 0 \\ b_3 \\ b_4 \end{bmatrix} y_p$$

Where,

$$\begin{aligned}
D &= (N_{\dot{\psi}} - I_z)(Y_{\dot{v}} - m) - N_{\dot{v}}Y_{\dot{\psi}} \\
a_{31} &= D^{-1}T/L[(N_{\dot{\psi}} - I_z) - x_p Y_{\dot{\psi}}] \\
a_{32} &= D^{-1}\{(Y_v u + T(1 + x_p/L))(N_{\dot{\psi}} - I_z) - Y_{\dot{\psi}}[N_v u + Tx_p(1 + x_p/L)]\} \\
a_{33} &= D^{-1}[N_{\dot{v}}Y_{\dot{\psi}} - Y_v(N_{\dot{\psi}} - I_z)] \\
a_{34} &= D^{-1}\{(Y_{\dot{v}} u - Y_{\dot{\psi}})(N_{\dot{\psi}} - I_z) - Y_{\dot{\psi}}(N_{\dot{v}} u - N_{\dot{\psi}})\} \\
a_{41} &= D^{-1}T/L[x_p(Y_{\dot{v}} - m) - N_{\dot{v}}] \\
a_{42} &= D^{-1}\{(Y_{\dot{v}} - m)[N_v u + Tx_p(1 + x_p/L)] - N_{\dot{v}}[Y_v u + T(1 + x_p/L)]\} \\
a_{43} &= D^{-1}[N_{\dot{v}}Y_v - N_v(Y_{\dot{v}} - m)] \\
a_{44} &= D^{-1}[N_{\dot{v}}Y_{\dot{\psi}} - N_{\dot{\psi}}Y_{\dot{v}} + (N_{\dot{\psi}} - N_{\dot{v}}u)m] \\
b_3 &= D^{-1}T[(N_{\dot{\psi}} - I_z)/L - Y_{\dot{\psi}}(1 + x_p/L)] \\
b_4 &= D^{-1}T[(Y_{\dot{v}} - m)(1 + x_p/L) - N_{\dot{v}}/L]
\end{aligned}$$

Figure 3 is a block diagram representing the physical system. For implementation with Matrix_x, each element of the A and B matrices represents a gain block.

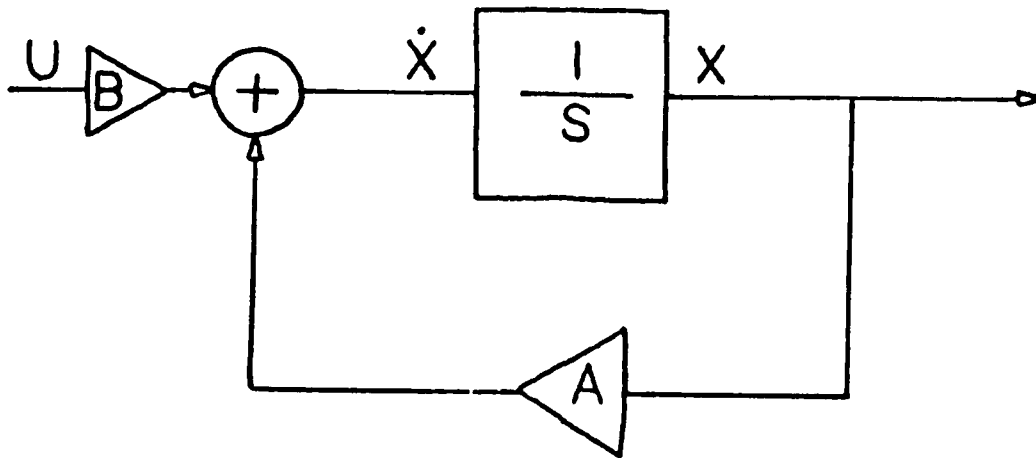

Figure 3. Plant Block Diagram

C. CONTROLLER DESIGN

If the control, y_p , is proportional to the state of the physical system, $\{X\}$, then y_p can be expressed as

$$\begin{aligned} y_p &= -\{K\}\{X\} \\ &= -K_1 X_1 - K_2 X_2 - K_3 X_3 - K_4 X_4 \end{aligned}$$

where $\{K\}$ are the proportional gains. Then, the system of equations represented by equation (12) can be rewritten as

$$\{\dot{X}\} = [A]\{X\} - \{B\}\{K\}\{X\} \quad (13)$$

$$= ([A] - \{B\}\{K\})\{X\} \quad (13A)$$

Taking the Laplace transform of equation (13) yields,

$$s\{X(s)\} = [A]\{X(s)\} - \{B\}\{K\}\{X(s)\},$$

or,

$$s\{X(s)\} - [A]\{X(s)\} + \{B\}\{K\}\{X(s)\} = \{0\}$$

So,

$$(s[I] - [A] + \{B\}\{K\})\{X(s)\} = \{0\} \text{ and}$$

$$([A] - \{B\}\{K\} - s[I])\{X(s)\} = \{0\},$$

where $[I]$ is the identity matrix. The closed-loop eigenvalues of this system are given by

$$|[A] - \{B\}\{K\} - s[I]| = 0. \quad (14)$$

Since the pair (A,B) is, in general, controllable, values of K can be chosen which will yield any desired eigenvalues. Applying equation (14) to the towing equations

of motion yields,

$$\left| \begin{bmatrix} 0 & 0 & 1 & 0 \\ 0 & 0 & 0 & 1 \\ a_{31} & a_{32} & a_{33} & a_{34} \\ a_{41} & a_{42} & a_{43} & a_{44} \end{bmatrix} - \begin{bmatrix} 0 & 0 & 0 & 0 \\ 0 & 0 & 0 & 0 \\ b_3 k_1 & b_3 k_2 & b_3 k_3 & b_3 k_4 \\ b_4 k_1 & b_4 k_2 & b_4 k_3 & b_4 k_4 \end{bmatrix} - \begin{bmatrix} s & 0 & 0 & 0 \\ 0 & s & 0 & 0 \\ 0 & 0 & s & 0 \\ 0 & 0 & 0 & s \end{bmatrix} \right| =$$

$$\left| \begin{bmatrix} -s & 0 & 1 & 0 \\ 0 & -s & 0 & 1 \\ a_{31} - b_3 k_1 & a_{32} - b_3 k_2 & a_{33} - b_3 k_3 - s & a_{34} - b_3 k_4 \\ a_{41} - b_4 k_1 & a_{42} - b_4 k_2 & a_{43} - b_4 k_3 & a_{44} - b_4 k_4 - s \end{bmatrix} \right| = 0$$

If the desired eigenvalues are s_1 , s_2 , s_3 , and s_4 , then the desired characteristic equation is

$$(s-s_1)(s-s_2)(s-s_3)(s-s_4)=0. \quad (15)$$

For a stable system, one in which the poles of the transfer function are in the left half of the complex plane, the eigenvalues must have negative real parts. Values of K can be found by equating the s-term coefficients of equation (14) with those of equation (15). The control law can then be written as

$$y_p = -(k_1 \ k_2 \ k_3 \ k_4) \begin{bmatrix} X_1 \\ X_2 \\ X_3 \\ X_4 \end{bmatrix} \quad (16)$$

D. OBSERVER DESIGN

The control, y_p , is a linear function of the state variables X_1 , X_2 , X_3 , and X_4 . These state variables represent the cross track error from the straightline path, the yaw angle, the sway velocity and the yaw angular

velocity. Though required as input to the controller, one or more variables may not be measurable. In particular, it may be difficult to measure the y-distance from the path and sway velocity. Both yaw angle and yaw angular velocity could be measured, but for the purposes of this research, it is assumed that only the measure of the yaw angle is available. In this case, estimates of the remaining three state variables must be made and provided as input to the controller. Since three of the four variables are unmeasurable, a full-order observer will be designed. The measurable output, y , of the physical system (plant) can be described by

$$\{y\} = \{C\}\{X\}. \quad (17)$$

Upon expanding this system of equations

$$\begin{aligned} \psi &= \{C_1 \ C_2 \ C_3 \ C_4\} \{X_1 \ X_2 \ X_3 \ X_4\}^T \\ &= \{0 \ 1 \ 0 \ 0\} \{X_1 \ X_2 \ X_3 \ X_4\}^T \end{aligned}$$

If the approximations of X_1 , X_2 , X_3 , and X_4 are denoted by \hat{X}_1 , \hat{X}_2 , \hat{X}_3 , and \hat{X}_4 , then the control law becomes

$$y_p = -\{K\}\{\hat{X}\}, \quad (18)$$

and the plant model can be described by

$$\dot{\{\hat{X}\}} = \{A\}\{\hat{X}\} + \{B\}y_p.$$

The plant model can be corrected by feeding back the difference between the actual plant output and the plant model output. The result is the observer equation,

$$\dot{\{\hat{X}\}} = \{A\}\{\hat{X}\} + \{B\}y_p + \{L\}(\{y\} - \{C\}\{\hat{X}\}), \quad (19)$$

where $\{L\}$ is the observer gain vector. The error between the plant and the plant model is

$$\begin{aligned}\dot{\{X\}} - \dot{\{\hat{X}\}} &= [A]\{X\} + \{B\}y_p - [A]\{\hat{X}\} - \{B\}y_p - \{L\}(\{Y\} - \{C\}\{\hat{X}\}) \\ &= [A](\{X\} - \{\hat{X}\}) - \{L\}\{C\}(\{X\} - \{\hat{X}\}) \\ &= ([A] - \{L\}\{C\})(\{X\} - \{\hat{X}\}).\end{aligned}$$

It is then clear that the error dynamics are governed by the eigenvalues of

$$[A] - \{L\}\{C\}.$$

It is also desirable that the error die out quickly, with respect to the dynamics of the plant. Since

$$|[A] - \{L\}\{C\} - s[I]| = 0, \quad (20)$$

it is possible to pick values of L such that the resulting eigenvalues fall to the left of the plant eigenvalues in the s -plane. If it is noted that the eigenvalues of

$$[A] - \{L\}\{C\}$$

are the same as the eigenvalues of

$$([A] - \{L\}\{C\})^T = [A]^T - \{C\}^T \{L\}^T,$$

then equation (20) can be rewritten as

$$|[A]^T - \{C\}^T \{L\}^T - s[I]| = 0, \quad (21)$$

and values of L can be determined using the same method as that used to determine the values of the controller gain, $\{K\}$. The block diagram of the observer is shown in Figure 4, and a block diagram of the complete system (plant, observer, controller) is shown in Figure 5.

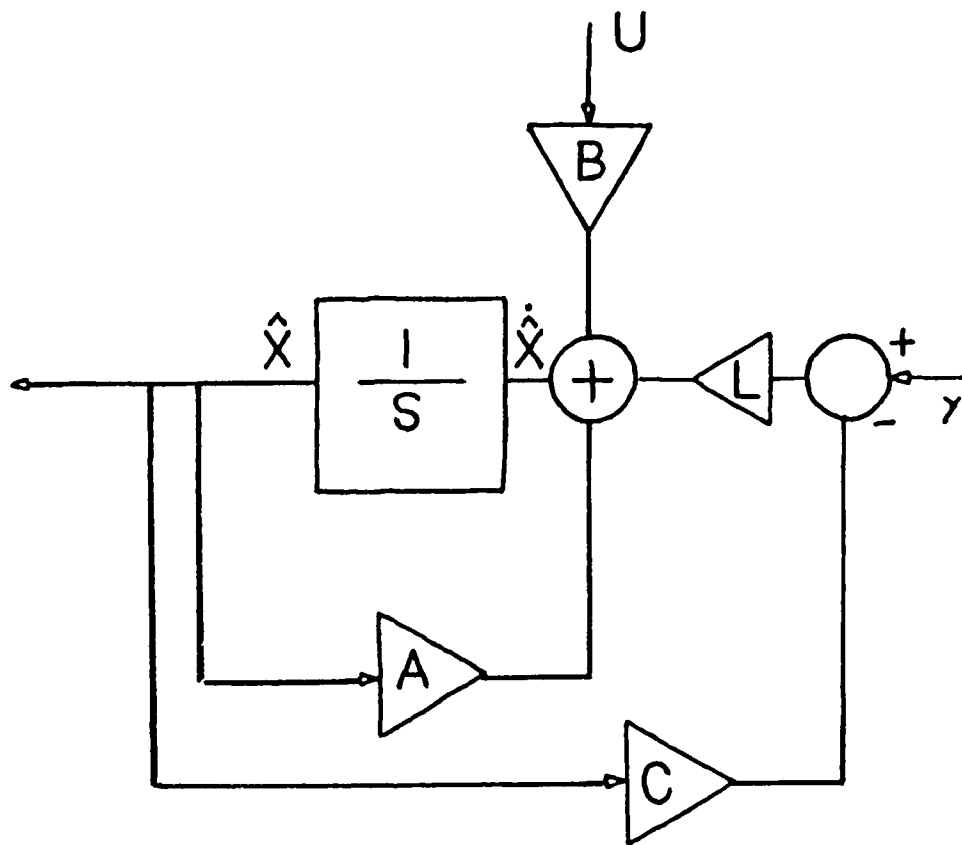

Figure 4. Observer Block Diagram

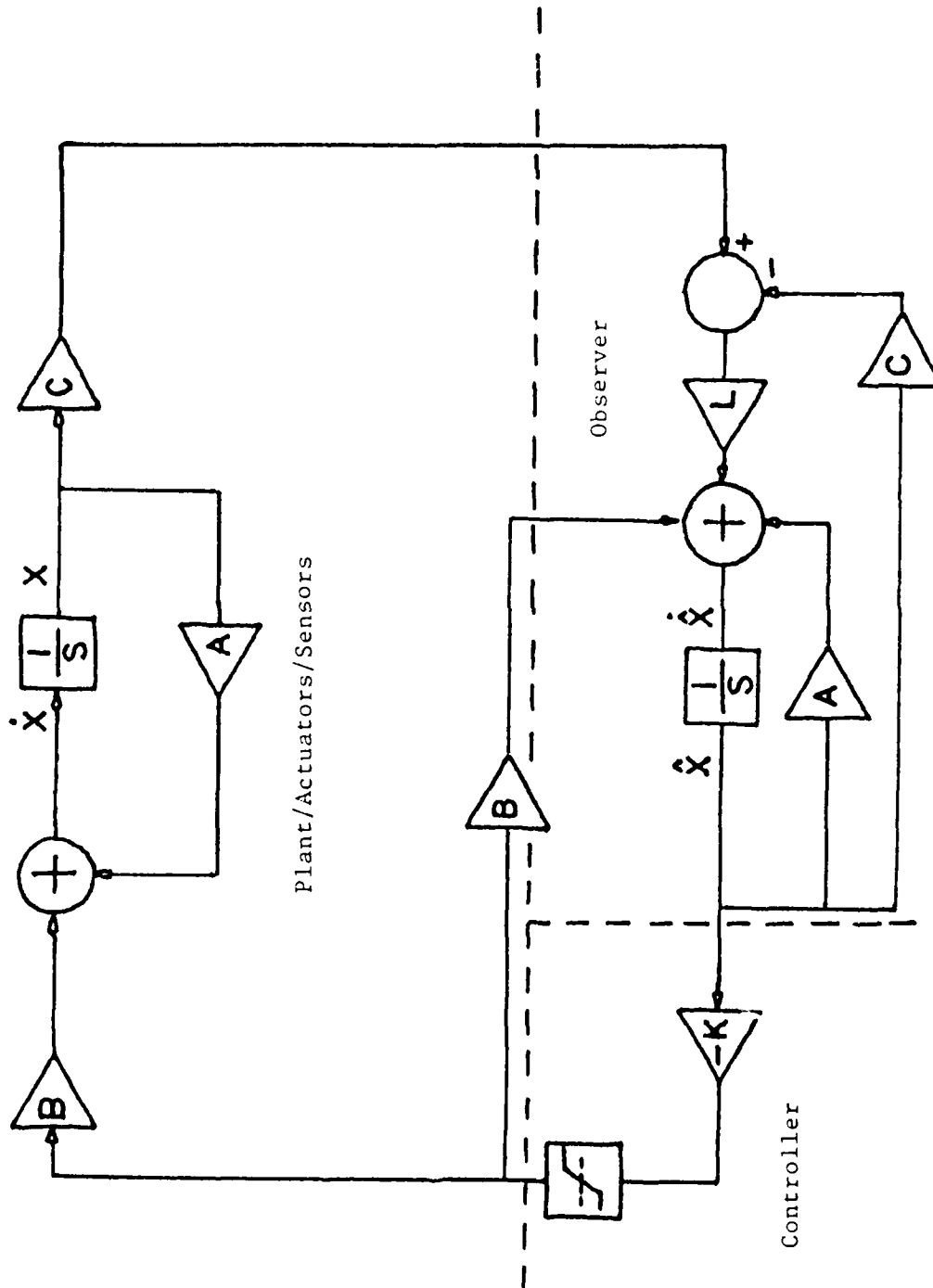

Figure 5. Plant/Compensator Block Diagram

E. MATRIX_X IMPLEMENTATION

The implementation of a single-input single-output system using Matrix_X is straight forward. The coefficients in the [A] matrix, and the {B}, {C}, {K} and {L} vectors are constant with respect to time. The [A] matrix is determined by the hydrodynamic derivatives associated with a particular vessel, the towline tension, the towline length, the distance from the center of gravity forward to the towline attachment point, and the velocity component, u . The {C} vector is simply determined by which outputs are measurable. The {K} and {L} vectors are determined using the "poleplace" command available in Matrix_X. The user can input the closed loop observer and controller poles interactively. Quite simply, Matrix_X takes the drudgery out of the linear algebra associated with developing a control system.

Of more interest perhaps, are the System-Build and Simulate functions of Matrix_X. The block diagrams implemented using Matrix_X have been included in the Appendix. The initial condition of the integrator between \dot{X}_1 and X_1 was set to 0.2, simulating an off-path condition. The effect of the control system was to bring the vessel back on path. Plots of y , v , y_p and ψ , are immediately available as output.

Program listings for the control system with observer and the control system without the observer are included in the Appendix.

III. RESULTS

The results are presented graphically, and with the exception of yaw angle, are in nondimensional form. Yaw angle is in degrees. The relationships describing the nondimensional quantities are included in the Appendix.

Three vessels were studied:

1. 191.6 foot barge
2. 1066.3 foot tanker
3. 528 foot mariner

A summary of the hull particulars and hydrodynamic derivatives for each of these vessels is included in the Appendix. The mariner and the barge are stable at the four knot forward velocity used in this study. The tanker is unstable. A nondimensional towline length of 2.5 was used throughout. The nondimensional towline tension was taken from resistance curves for each of the vessels at four knots. The nondimensional longitudinal distance from the center of gravity to the towline attachment point was assumed to be 0.5, and is also constant throughout. The observer poles were selected to be five times more negative than the controller poles. Obviously, the towline attachment point can move only a finite distance to port and starboard. This distance is ultimately limited by the beam of the vessel in question. Various values were used, but

the maximum value used was 0.1. Reducing this control saturation point sufficiently will result in the inability of the controller to stabilize the response. Four plots were generated for each simulation. The y-distance from the path, the towline attachment point lateral offset, the sway velocity and the yaw angle are all plotted versus nondimensional time. Where the observer is implemented, the estimates of y , v , and ψ are incorporated in the graphs of y , v , and ψ .

A. MARINER

1. Figures 6 and 7: With Observer/Without Control

The block diagram used in this simulation is shown in Figure 6. Towline attachment point movement is limited to zero in the controller. These graphs illustrate the straight line stability of the mariner, with no control. Notice that y , v , and ψ all oscillate about zero before a straightline path is achieved. The straightline path condition is reached in a nondimensional time of about 60.

2. Figures 8 and 9: Without Observer/With Control

Effectiveness of the controller is directly related to the accuracy of the state estimates. The block diagram used in this simulation is shown in Figure 8. The plant outputs are all assumed measurable, and are used as inputs to the controller. Notice that there is no overshoot in y , v , and ψ , and a straightline path is achieved in a

HINTS

Continuous Super-Block Ext. Inputs Ext. Outputs
 CSYSTEMMO 0 10

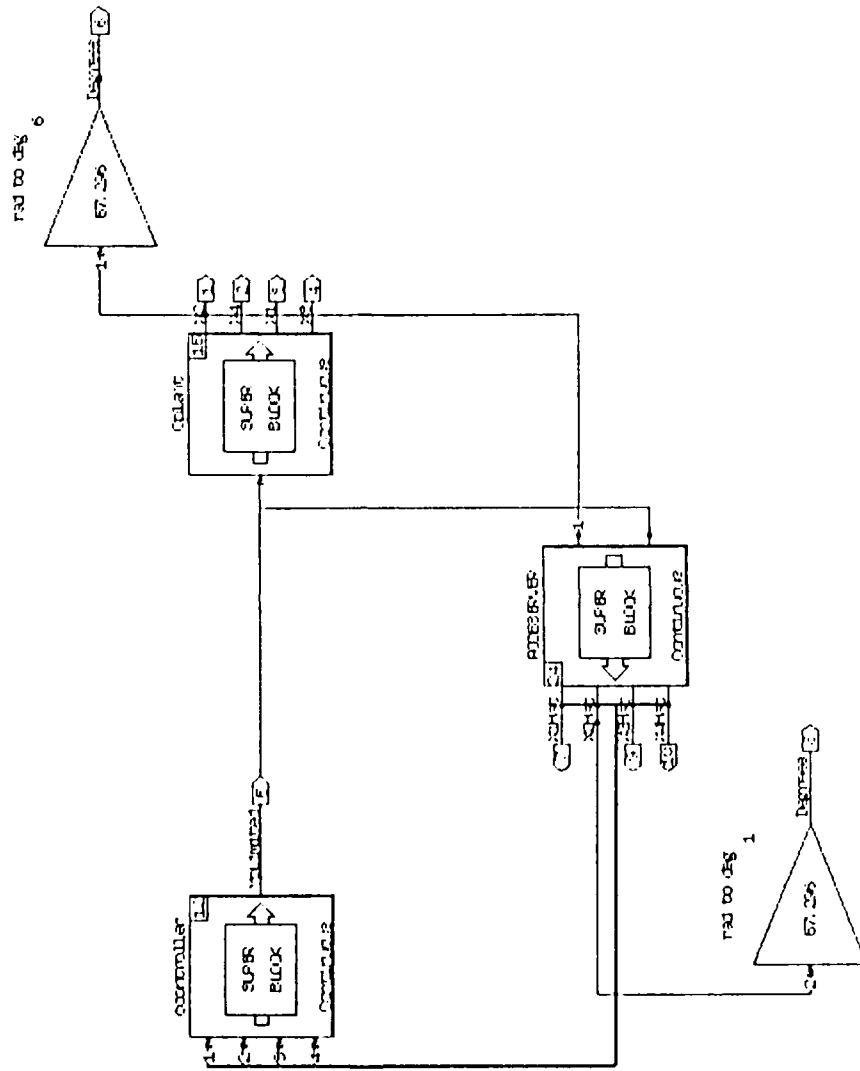

Figure 6. Matrix_x Plant/Compensator Block Diagram

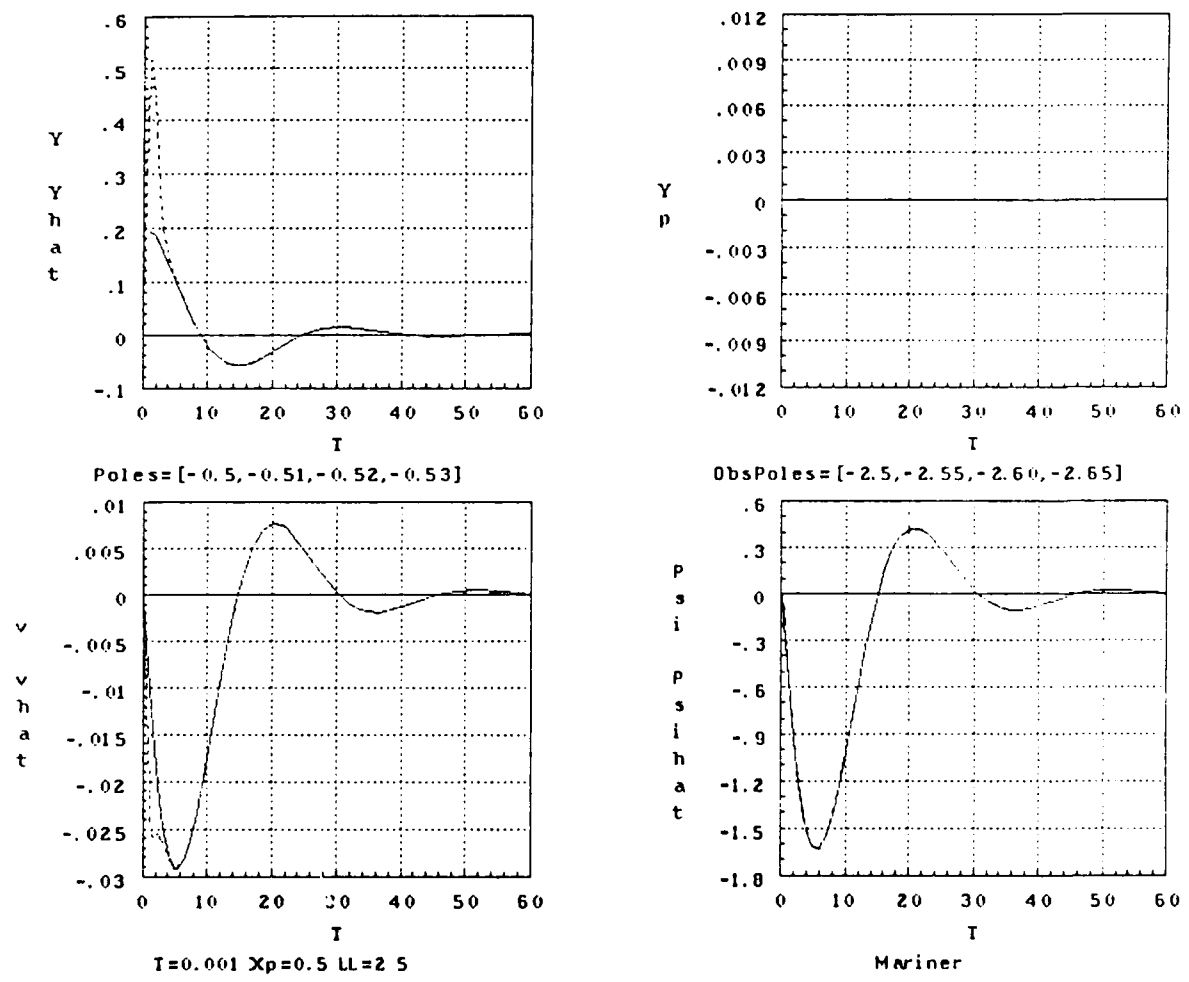

Figure 7. Mariner With Observer/Without Control

HINTS

Continuous Super-Block Ext. Inputs Ext. Outputs
caystem 0 5

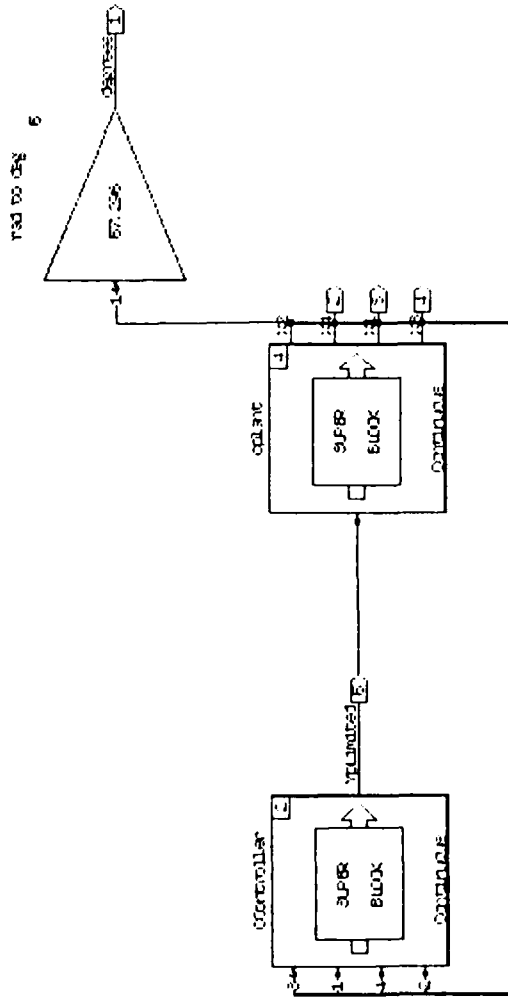
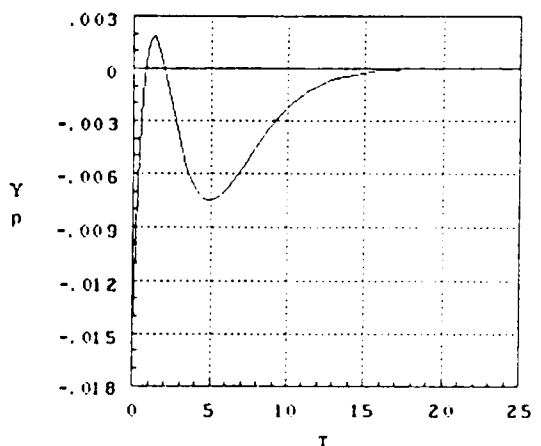
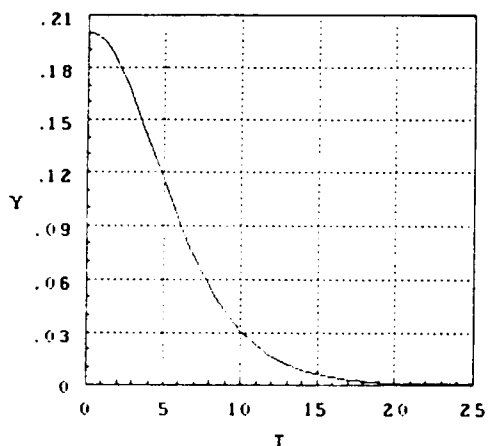
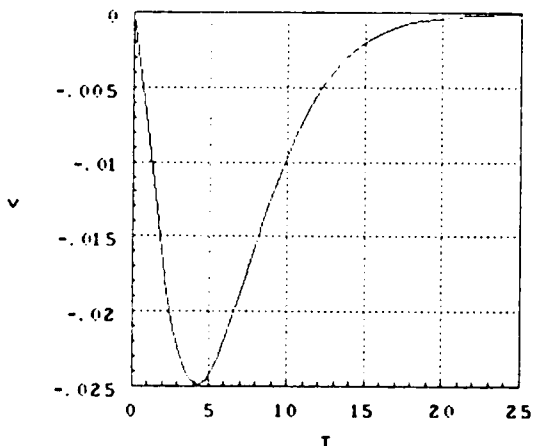

Figure 8. Matrix_x Plant/Controller Block Diagram



Poles = [-0.5, -0.51, -0.52, -0.53]



T=0.001 Xp=0.5 LL=2.5

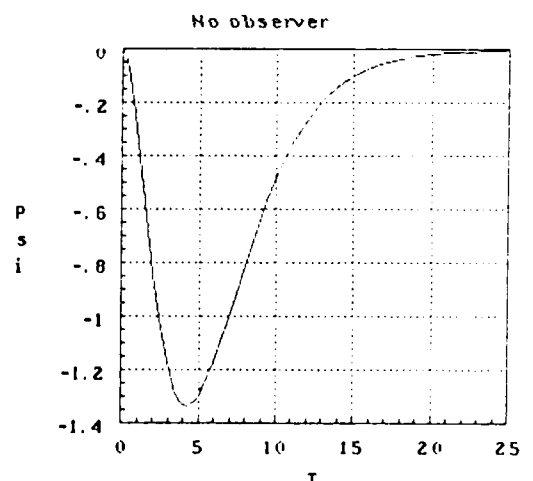

No observer

Mariner

Figure 9. Mariner Without Observer/With Control

nondimensional time of about 25. The maximum lateral offset of the towline attachment commanded by the controller is about 0.014.

3. Figure 10: With Observer/With Control

The block diagram used for this simulation is Figure 6. However, lateral towline attachment point movement is now limited to -0.1 to 0.1. A straightline path condition is reached in a nondimensional time of 20 to 25, but almost two times as much control effort is required as was without the observer. Also, note that there is some small overshoot in y , v , and ψ . Clearly, initial errors in the state estimates have degraded the performance of the system.

B. BARGE

1. Figure 11: With Observer/Without Control

The block diagram used for this simulation is Figure 6. Again, lateral movement of the towline attachment point is limited to zero. Although the barge has straightline stability, note the errors in the estimates of y and v which are apparent in the graphs. A straight line path is achieved in a nondimensional time of about 20, but considerable oscillation in v and ψ takes place. Also of note is the fact that the yaw angle reaches a maximum value of about six degrees. This is significant. There is small overshoot in v and ψ .

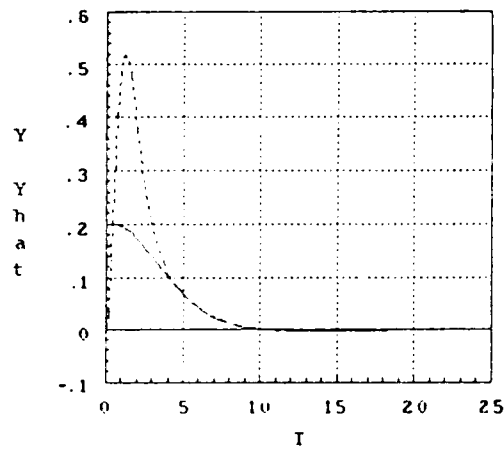

Poles = [-0.5, -0.51, -0.52, -0.53]

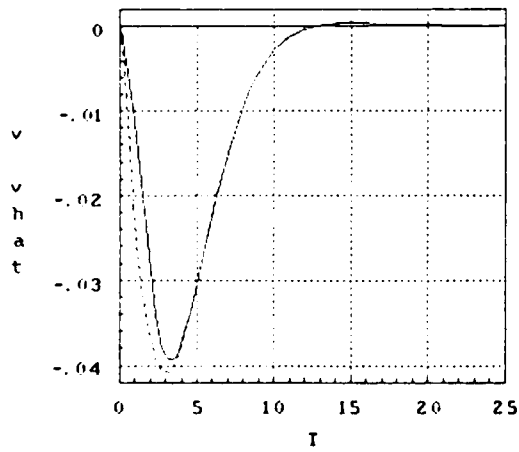

$T=0.001$ $X_p=0.5$ $LL=2.5$

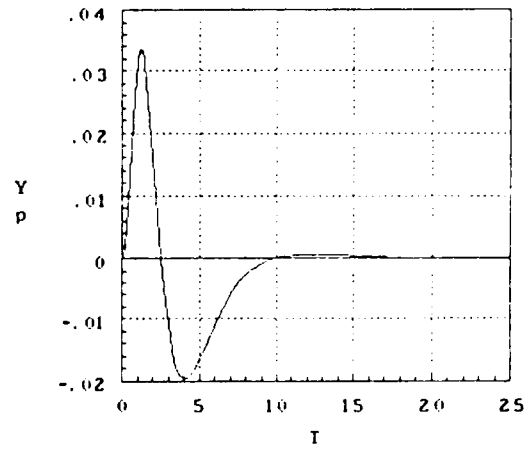

ObsPoles = [-2.5, -2.55, -2.60, -2.65]

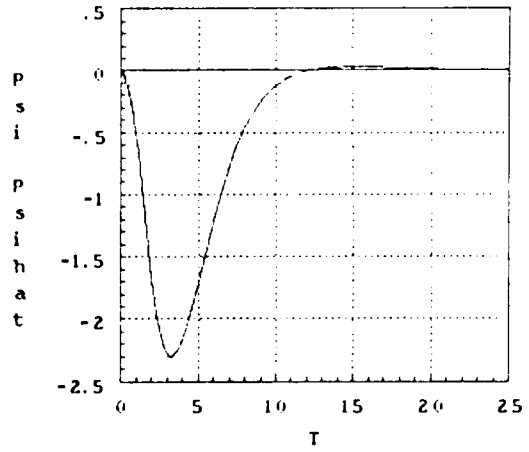

Mariner

Figure 10. Mariner With Observer/With Control

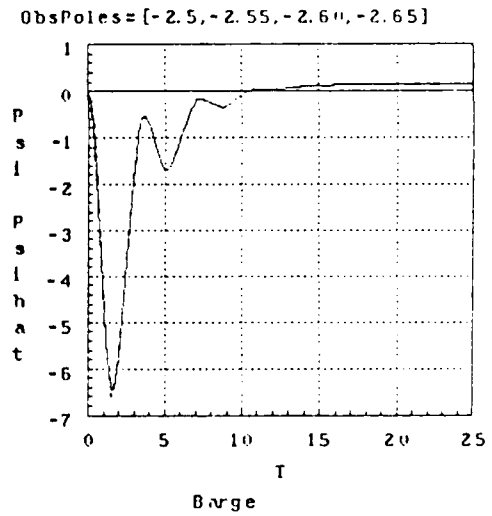
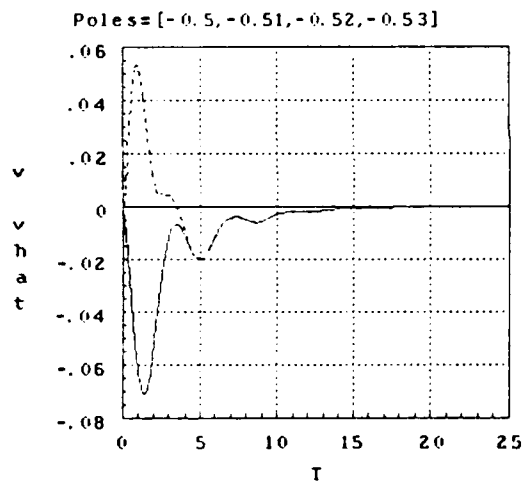
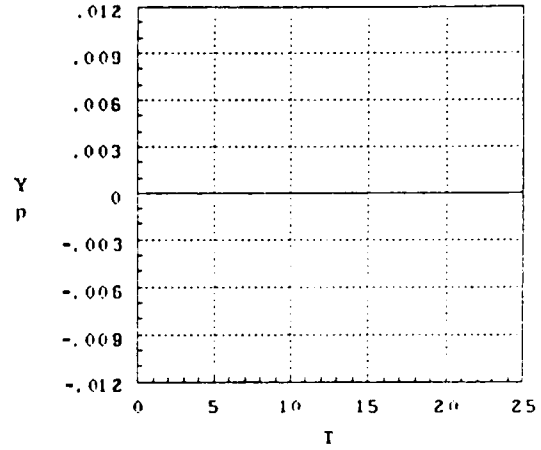
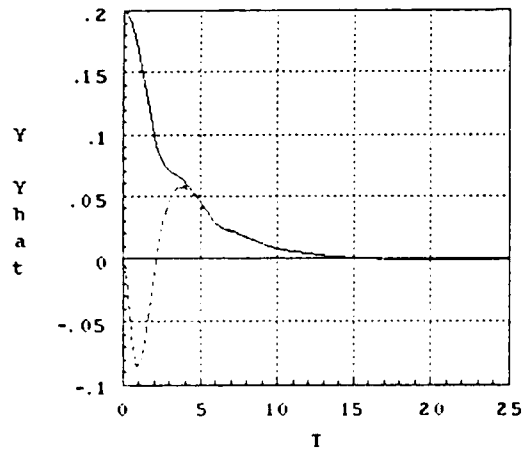

$T=0.015 \quad X_p=0.5 \quad LL=2.5$

Figure 11. Barge With Observer/Without Control

2. Figure 12: Without Observer/With Control

The block diagram used in this simulation is Figure 8. All plant outputs are again assumed to be measurable and applied as inputs to the controller. A straightline path is achieved in a nondimensional time of about 25. The maximum yaw angle has been reduced to about 1 degree, at the expense of considerably more overshoot in y , v , and ψ . Note that the maximum lateral offset of the towline attachment point is about 0.029.

3. Figure 13: With Observer/With Control

With the observer, about half as much control effort is required, but the maximum yaw angle reaches approximately 4.5 degrees. Overshoot in y and v is comparable to the simulation without the observer, and a straightline path is attained in a nondimensional time of about 25.

4. Figure 14: With Observer/With Control

This figure illustrates the effect of reducing the maximum allowable control effort to less than that which was used in Figure 13. Since the barge is stable, the control does not saturate at the 0.1 limit. For this simulation, the maximum lateral offset of the towline attachment point was reduced to 0.0045. A straightline path is achieved in about the same time as before, but the maximum yaw angle increases to about 5.5 degrees and the control is saturated twice. Higher sway velocity also results.

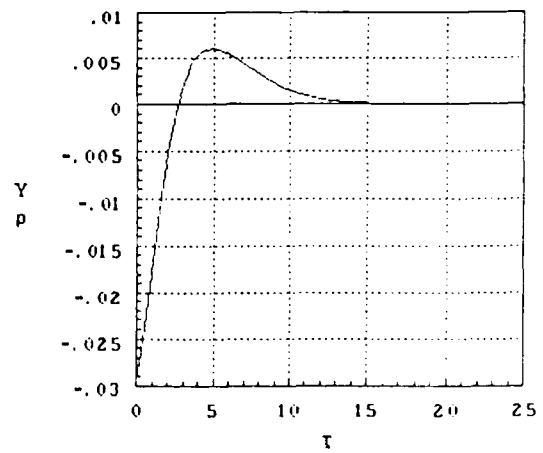
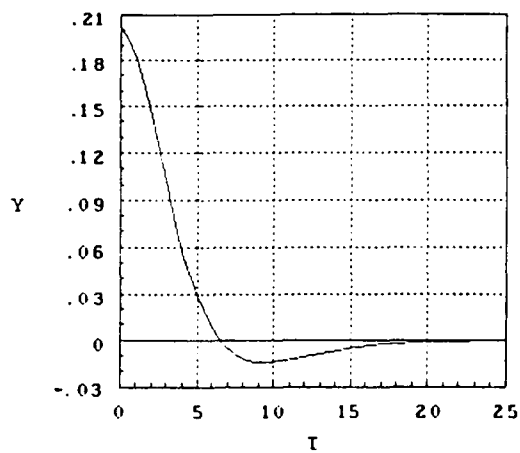

Poles = [-0.5, -0.51, -0.52, -0.53]

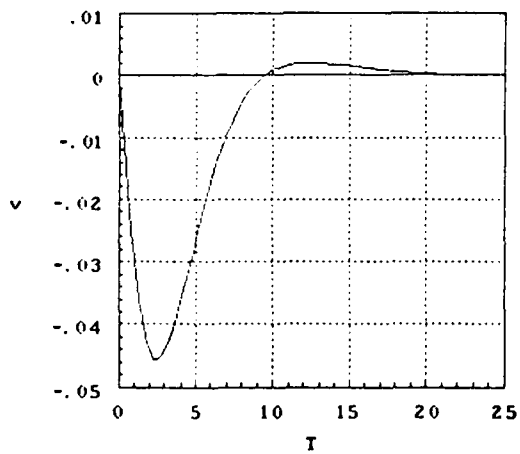

T=0.015 Xp=0.5 ll=2.5

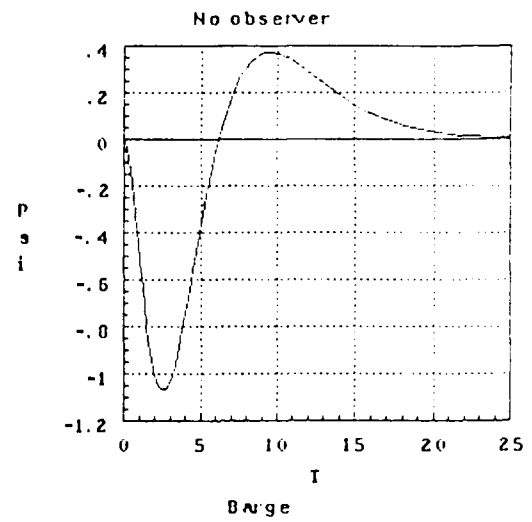
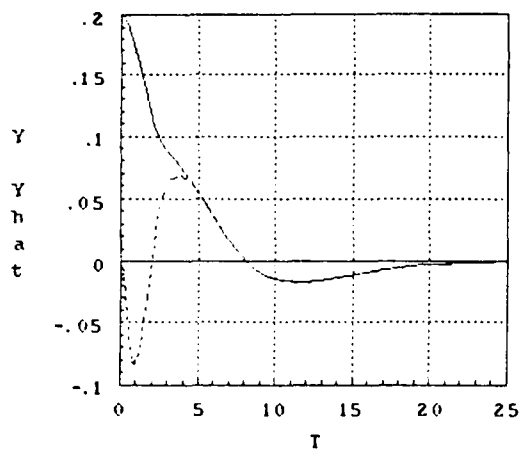
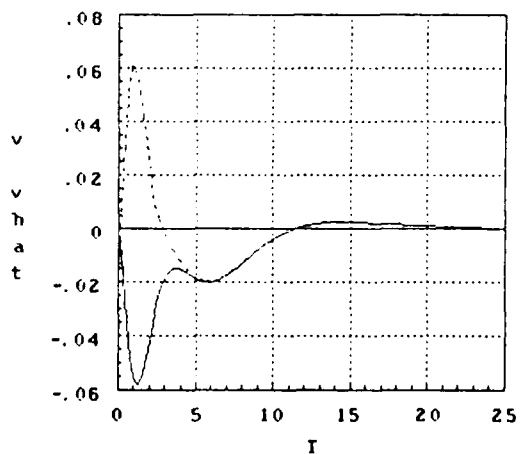

Figure 12. Barge Without Observer/With Control



Poles = [-0.5, -0.51, -0.52, -0.53]



T=0.015 Xp=0.5 LL=2.5

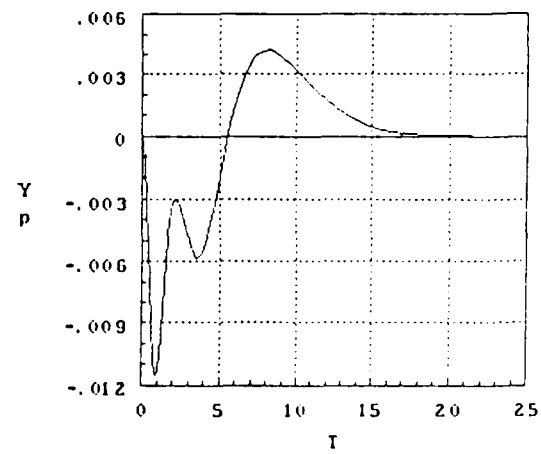

ObsPoles = [-2.5, -2.55, -2.60, -2.65]

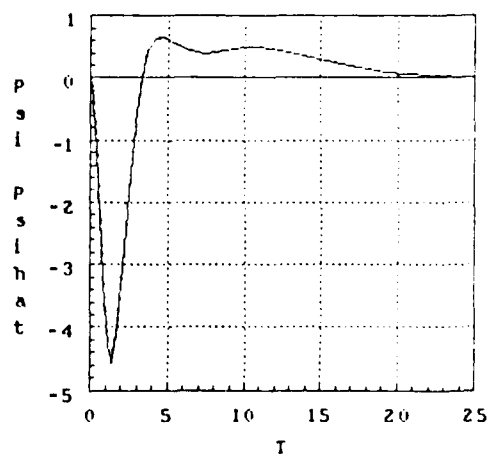

Figure 13. Barge With Observer/With Control

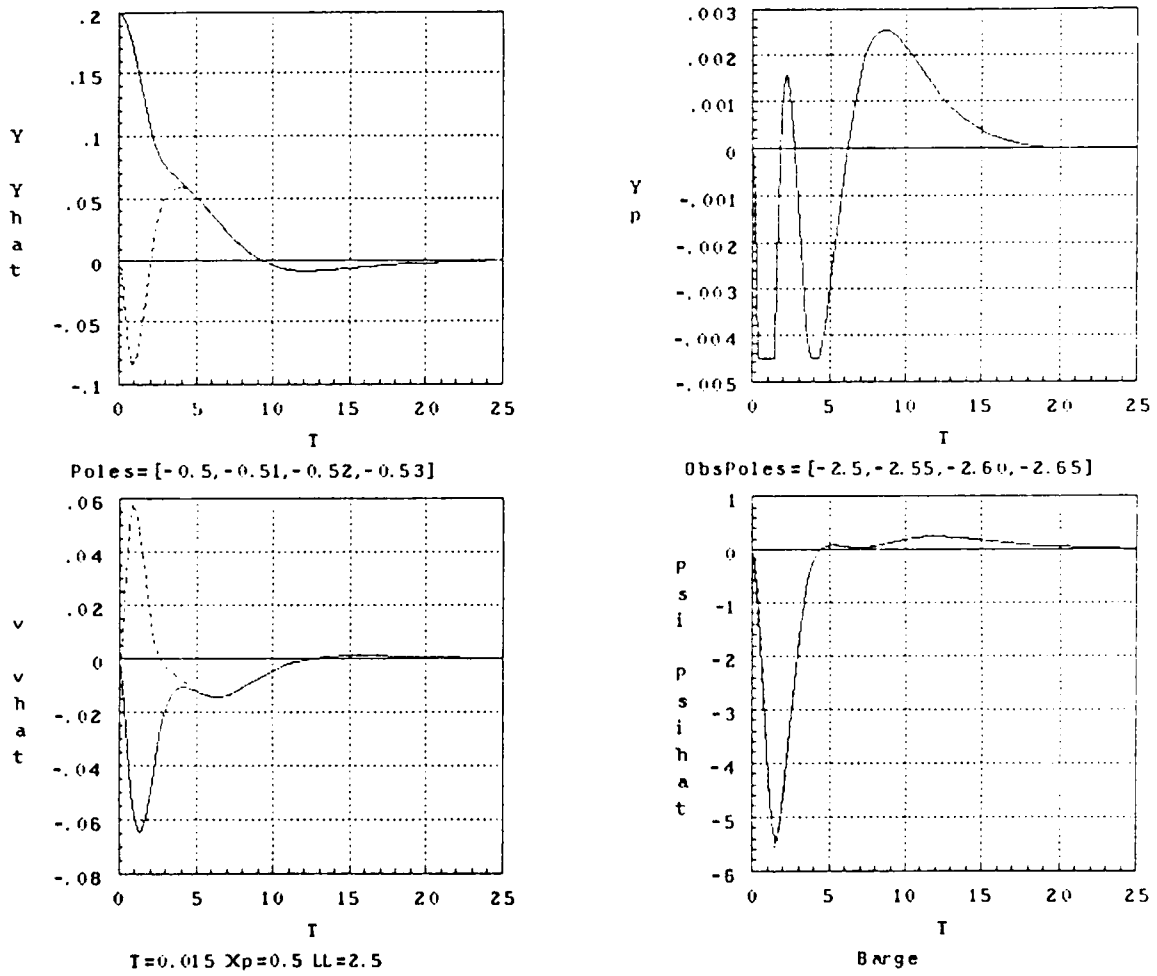

Figure 14. Barge With Observer/With Control (0.0045)

C. TANKER

Since the tanker is unstable, it makes for the best test of the control system. A test of the robustness of the control system is also performed, both with and without the observer.

1. Figure 15: With Observer/Without Control

This figure illustrates the unstable response of the tanker in the absence of control.

2. Figure 16: Without Observer/With Control

The control system achieves a straightline path in a nondimensional time of about 25, with no overshoot in y , v , or ψ . The maximum yaw angle attained is about 1.45 degrees and the towline attachment point only moves 0.06 ship lengths laterally. However, 0.06 ship lengths in dimensional form is approximately 64 feet for the tanker. This much lateral movement would require a beam in excess of 126 feet.

3. Figure 17: With Observer/With Control

For this simulation, a maximum towline attachment point lateral offset of 0.1 was used. Again, a straightline path was attained in a nondimensional time of about 25, but the yaw angle exceeded three degrees and the control was saturated twice. There is also overshoot in y , v , and ψ .

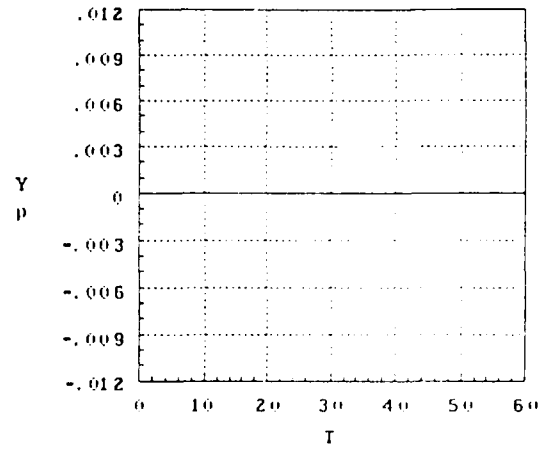
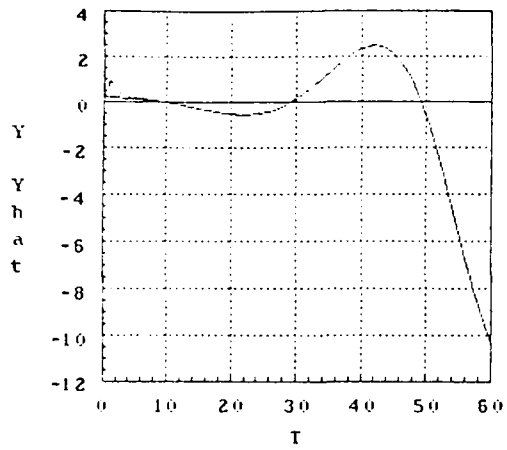

Poles = [-0.5, -0.51, -0.52, -0.53]

ObsPoles = [-2.5, -2.55, -2.6, -2.65]

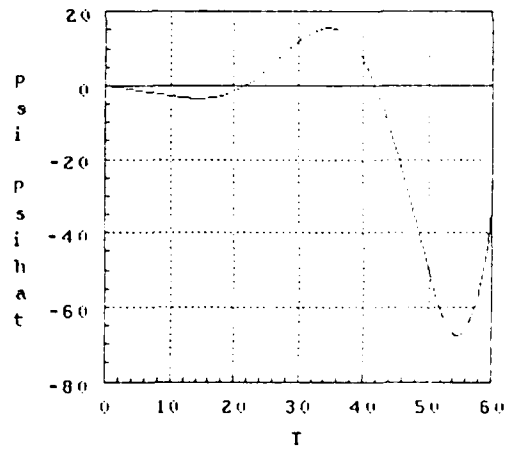
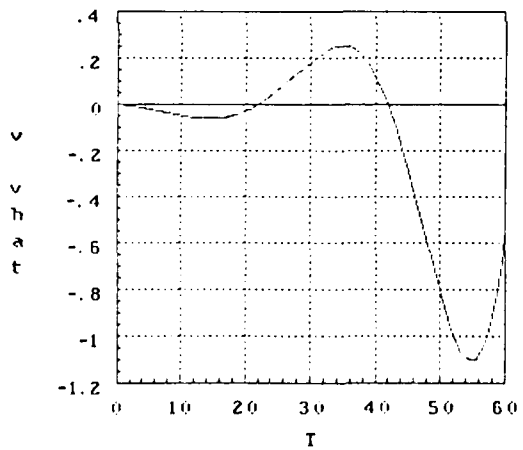

T=0.0005 Xp=0.5 ll=2.5

Tanker

Figure 15. Tanker With Observer/Without Control

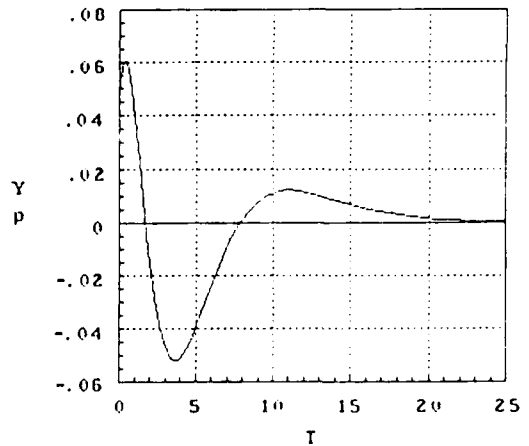
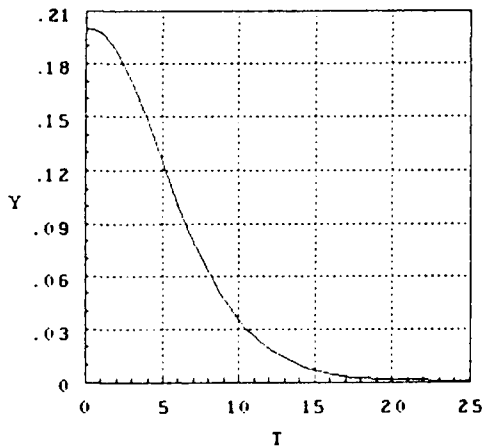

Poles = [-0.5, -0.51, -0.52, -0.53]

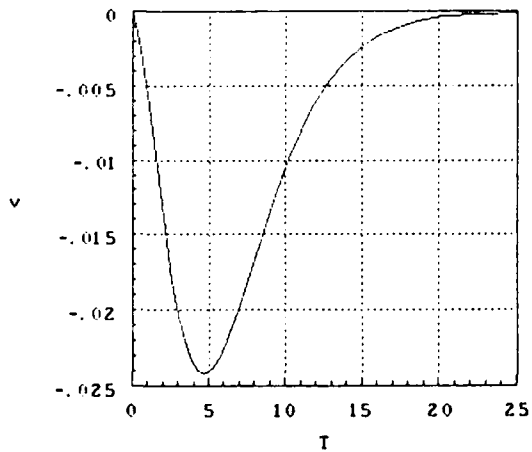

T=0.0005 Xp=0.5 LL=2.5

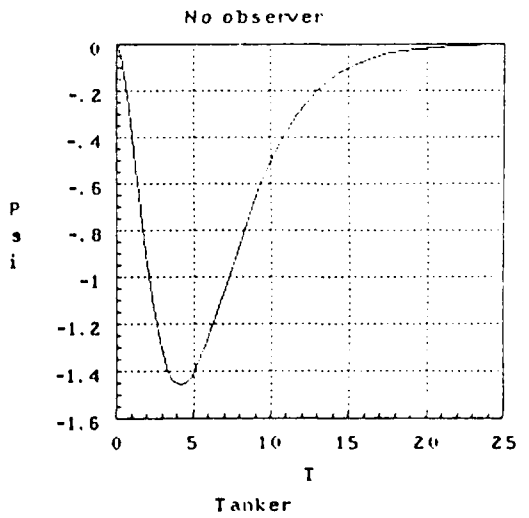

Figure 16. Tanker Without Observer/With Control

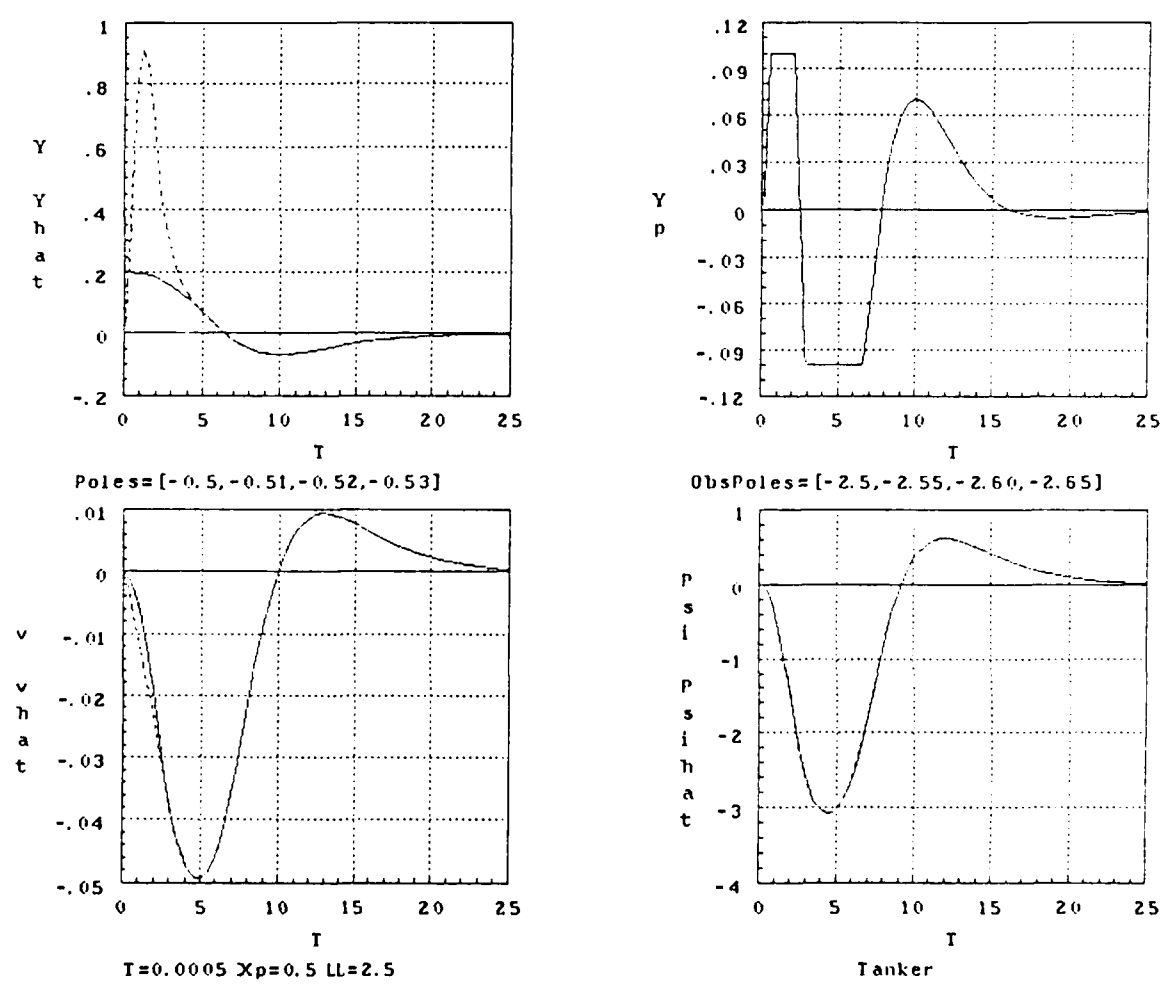

Figure 17. Tanker With Observer/With Control

4. Figure 18: With Observer/With Control

The control saturation limit was set to 0.05 for this simulation. A beam of greater than 107 feet would be required for the traversing mechanism. It takes considerably longer to attain a straightline path and the control is saturated three times. The overshoot in y , v , and ψ is greater. However, the maximum yaw angle attained is less than was observed with a saturation limit of 0.1.

5. Figure 19: With Observer/With Control

This simulation illustrates the effect of reducing the control saturation limit. The limit was set to 0.035, corresponding to a required beam of about 75 feet. Note that the response is unstable. In defense of the control system, it might be noted that the initial offset from the path of 0.2 ship lengths (213 feet) is significant.

6. Figure 20: Test For Robustness

This simulation was performed with the observer implemented and with control. It was assumed that the value of $\partial Y/\partial v$ was in error. This hydrodynamic derivative represents damping. Reducing the damping in the y -direction should destabilize the response to some extent. The original controller and observer gains were retained, but for purposes of modelling the plant, the reduced value was used. The magnitude of $\partial Y/\partial v$ was reduced by ten per cent. Clearly, the system is less stable than before, and takes a nondimensional time of about 50 to achieve a straightline

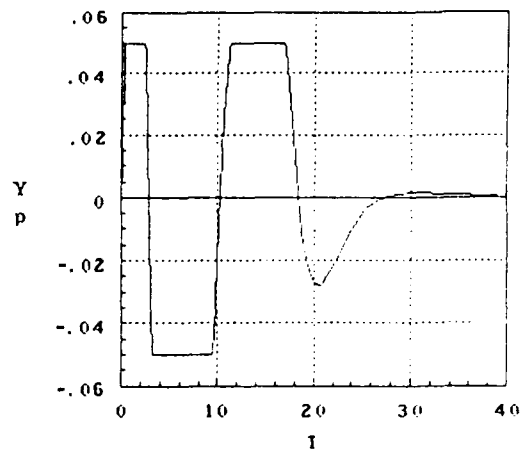
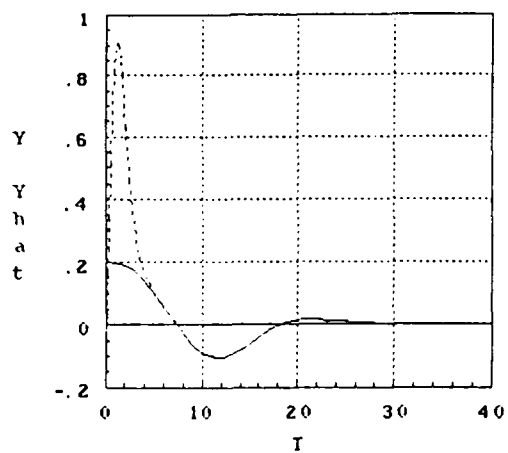

Poles = [-0.5, -0.51, -0.52, -0.53]

ObsPoles = [-2.5, -2.55, -2.60, -2.65]

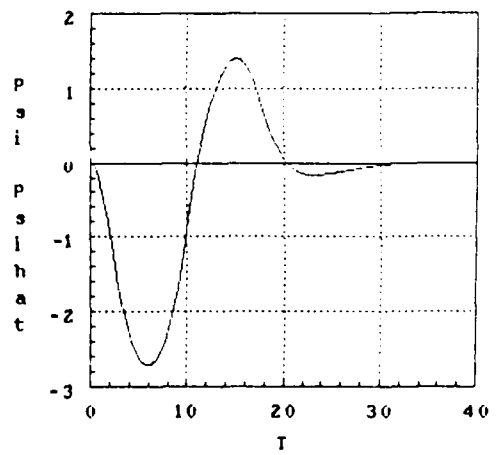
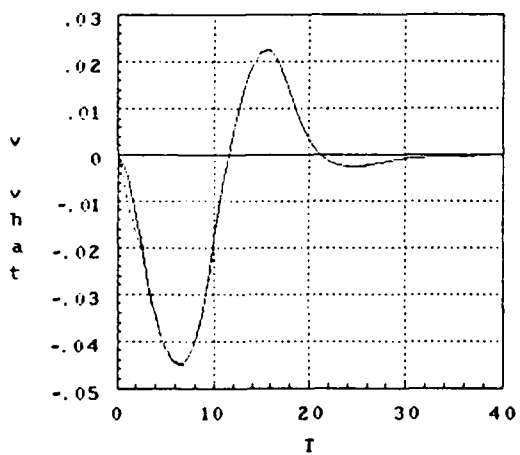

T=0.0005 Xp=0.5 ll=2.5

Tanker

Figure 18. Tanker With Observer/With Control (0.05)

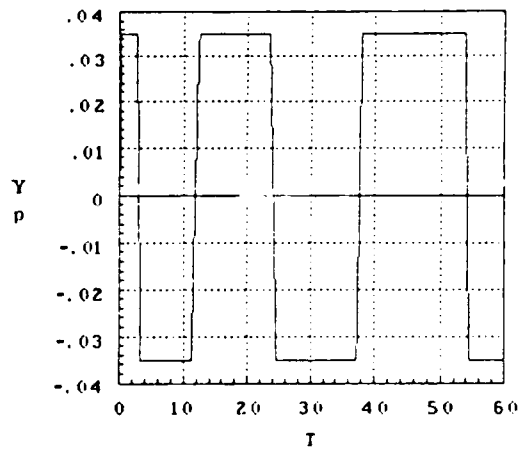
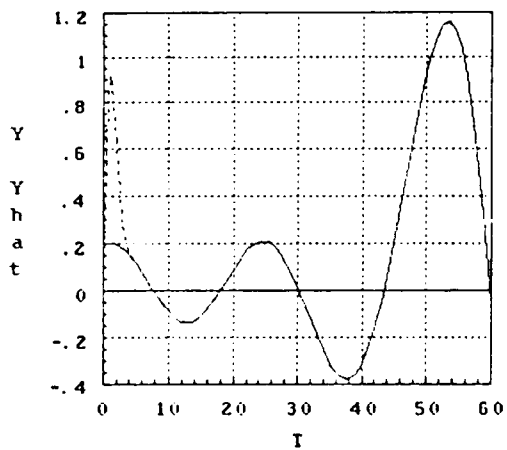

Poles = [-0.5, -0.51, -0.52, -0.53]

ObsPoles = [-2.5, -2.55, -2.60, -2.65]

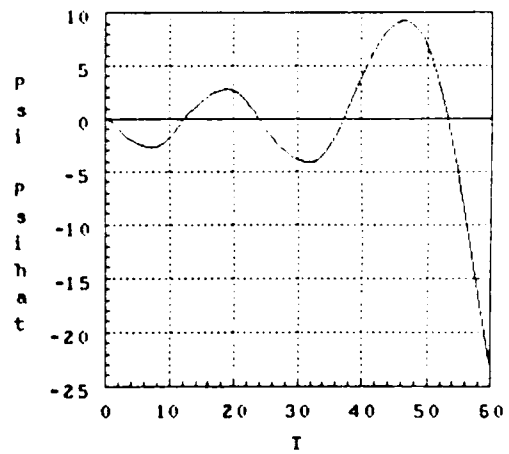
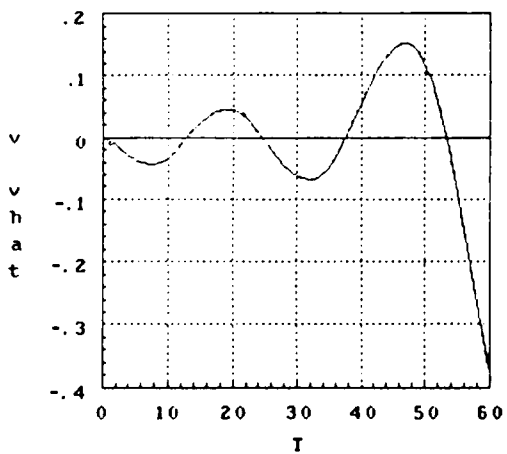

T=0.0005 Xp=0.5 LL=2.5

Tanker

Figure 19. Tanker With Observer/With Control (0.035)

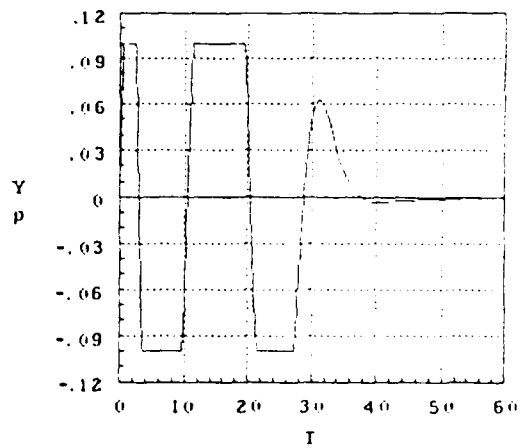
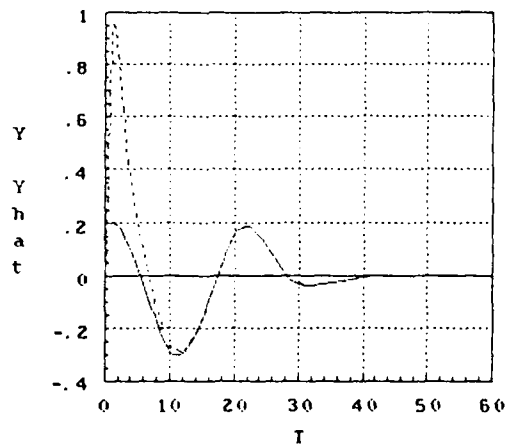

Poles = [-0.5, -0.51, -0.52, -0.53]

ObsPoles = [-2.5, -2.55, -2.60, -2.65]

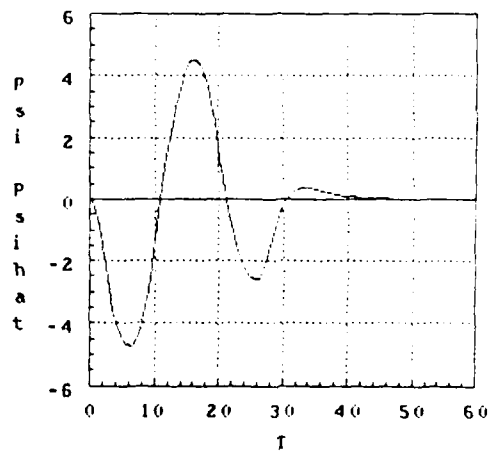
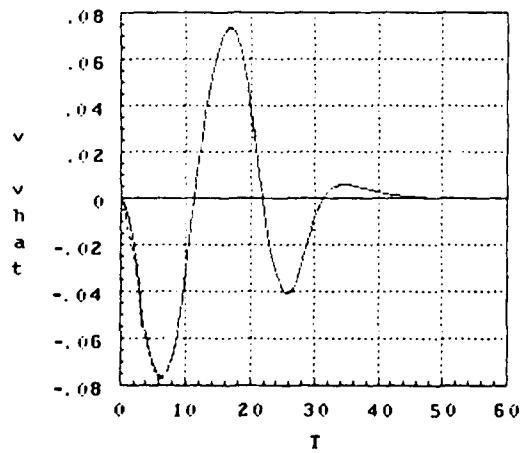

T=0.0005 Xp=0.5 Lt=2.5

Tanker

Figure 20. Tanker Robustness Test With Observer

path. The overshoot in y , v , and ψ is significantly greater, and a maximum yaw angle of almost five degrees is attained.

7. Figure 21: Test For Robustness

As mentioned previously, errors in the state estimates adversely impact the ability of the controller to stabilize the system. For this simulation the block diagram in Figure 8 was used. The plant outputs are assumed to be measurable. With a 65 per cent reduction in $\partial Y/\partial v$, the controller was still able to stabilize the response easily. Obviously, state estimate errors are degrading the performance of the system.

8. Figures 22 and 23: Without Observer/With Modified Controller

For the simulations that produced the results in these figures, the controller was modified. The gains acting on y and v were set to zero in the controller. This represents the inability to measure y and v . Then, it was assumed that both ψ and $\dot{\psi}$ could be measured, and applied as inputs to the controller. The state variables y and v were not estimated, so y_p was dependent solely on ψ and $\dot{\psi}$. Compare Figures 16 and 22. The difference between these two simulations is that in the first, y_p is dependent on y , v , ψ , and $\dot{\psi}$. In other words, all four state variables are assumed measurable and applied as inputs to the controller. In the latter, y_p is dependent on only ψ and $\dot{\psi}$. It is

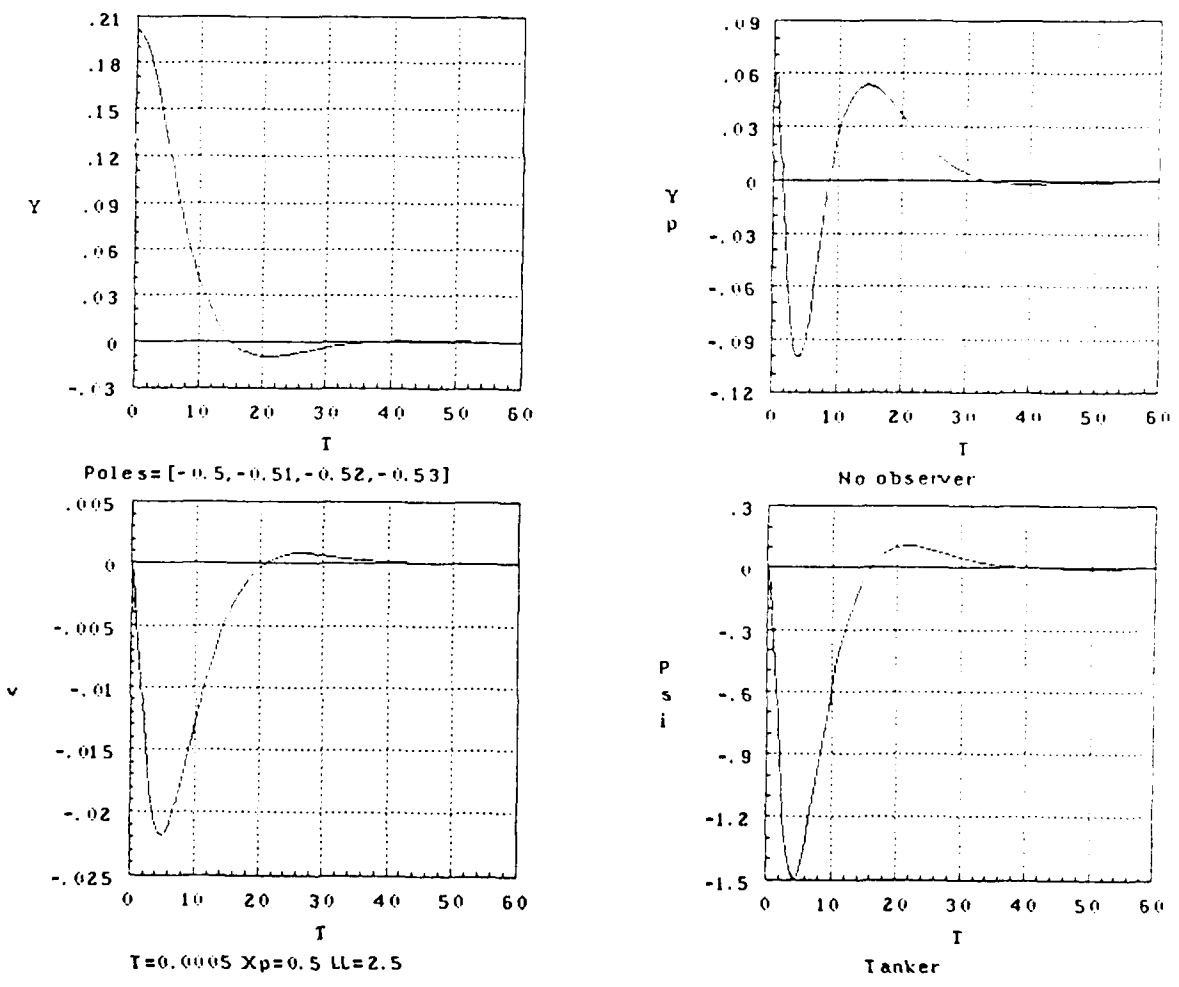
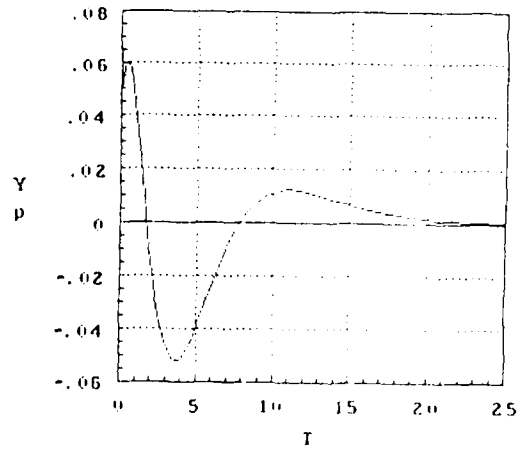
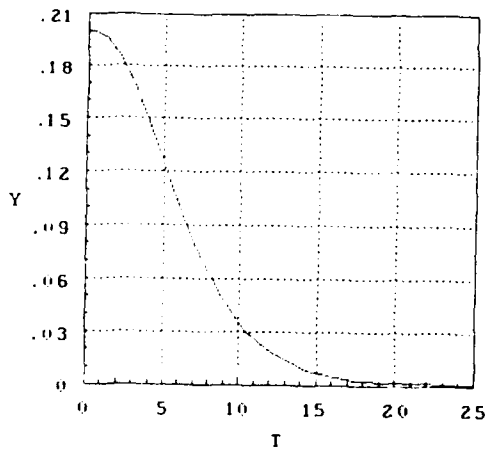
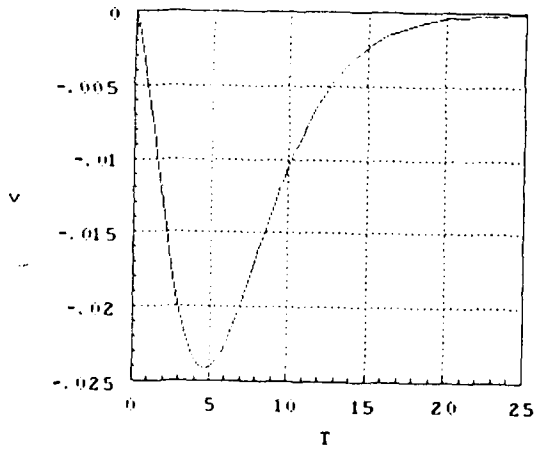

Figure 21. Tanker Robustness Test Without Observer



Poles = $[-0.5, -0.51, -0.52, -0.53]$



$T=0.0005$ $Xp=0.5$ $Ll=2.5$

No observer

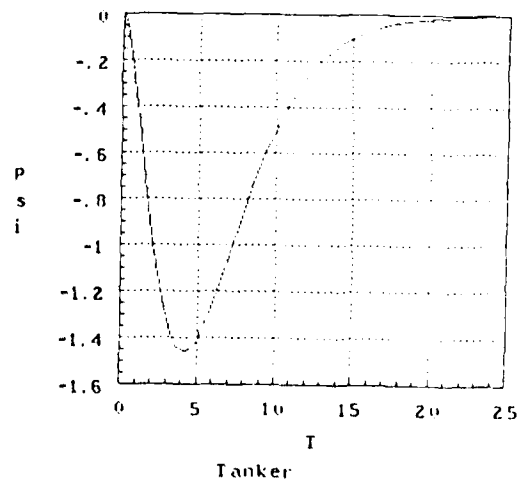

Tanker

Figure 22. Tanker Without Observer/With Mod. Cont.

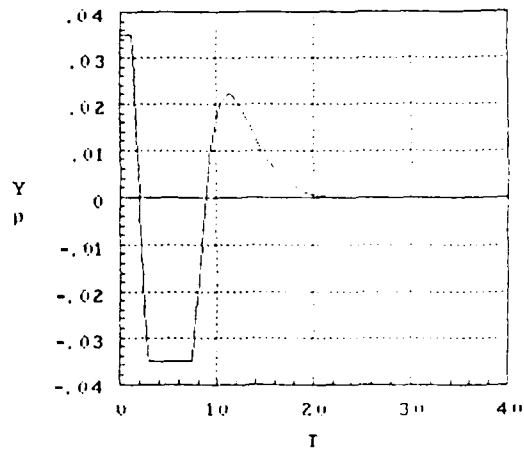
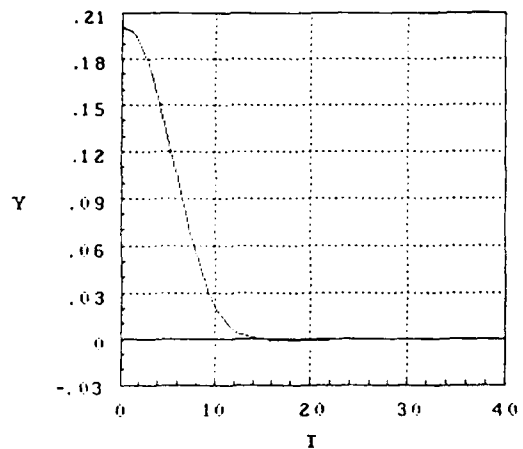

Poles = [-0.5, -0.51, -0.52, -0.53]

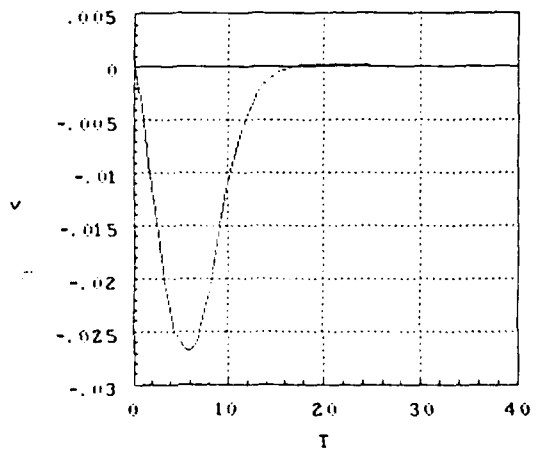

T=0.0005 Xp=0.5 LL=2.5

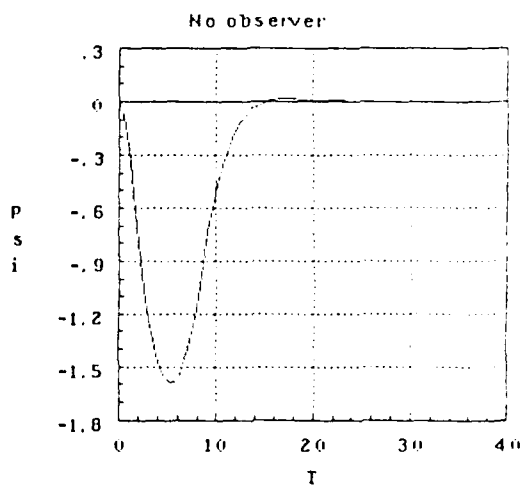

Tanker

Figure 23. Tanker Without Observer/With Mod. Cont. (0.035)

apparent that the controller performs in an almost identical fashion without v and y as inputs to the controller. Compare Figures 18 and 23. For both, the control is saturated at 0.035. The simulation represented by Figure 18 used the full order observer, assuming only ψ was measurable, and providing estimates for $\dot{\psi}$, y , and v . The performance of the modified controller, without estimates or measurements of v and y , is obviously much faster, with almost no overshoot in ψ , y , and v . It seems clear then, that not only does estimation of y and v fail to improve the performance of the compensator, it actually degrades its performance as compared to a system assuming measurement of ψ and $\dot{\psi}$.

IV. CONCLUSIONS AND RECOMMENDATIONS

A. CONCLUSIONS

This study investigated the possibility of athwartships movement of the towline attachment point as a means of improving the stability of towed vessels. The assumptions with respect to model linearity restrict its applicability to trajectories close to the path of the towing ship. Additionally, the controller design in combination with the full order observer did not prove to be exceptionally robust. In the absence of the observer, and assuming that measurements of ψ and $\dot{\psi}$ were possible, the compensator performed admirably and was able to tolerate a 65 per cent reduction in the value of the damping hydrodynamic derivative, Y_v . Determining whether or not lateral movement of the towline attachment point would provide a sufficient measure of control in and of itself, will require further study. It has been established in the literature that there are an infinite number of combinations of x_p and towline length that will provide for stability of the tow. Unfortunately, not all combinations of x_p and towline length are feasible. For the tanker, an x_p of greater than one would be required to ensure stability of the system with a nondimensional towline length of 2.5. This study has shown

that for the tanker, the distance y_p required to provide an acceptable measure of improvement in stability may be too large to be accommodated by the beam of the vessel. This distance may actually be larger than predicted, because no delay between command and movement of the attachment point was modeled. Some combination of increased x_p and movement of the towline attachment point would probably be a more effective means of control than either individually. Practical considerations may preclude the actual implementation of such a system.

The performance and robustness of the system was seriously degraded by errors in the state estimates. This was most evident in the barge simulations, and in the tests for robustness performed with the tanker model. The data indicate that the best compensator performance is obtained in the absence of state estimates for v and y . Measurement of ψ and $\dot{\psi}$ is possible, and in fact, the presence of measurements of v and y provided little improvement over simply measuring ψ and $\dot{\psi}$. Should further research prove this to be so, the cost and complexity associated with the entire observer can be avoided.

B. RECOMMENDATIONS

Modelling of the time delay between control command and response would result in a further increase in the amount of control effort required. As mentioned previously, some

combination of an increase in x_p and lateral movement of the towline attachment point may be workable. At any rate, an analysis based on the nonlinear equations of motion and modelling of the control time delay, would help to determine the feasibility of the system. The most apparent disadvantage of a y_p -only compensator, would seem to be the sheer size of the traversing mechanism required to provide the necessary control effort. Any reduction in the amount of control effort required, whether through increased towline tension or an increase in x_p , would improve the performance of the control system.

Additionally, to provide true pathkeeping stability in the presence of constant or time-variant disturbances, integral control needs to be implemented. Krikelis and Kavouras showed that the path of a towed vessel could be maintained within a narrow band using a nonlinear rudder control, in the presence of oblique currents of one knot, and wave action.[Ref. 4] Given the effectiveness of a rudder at low speeds, it should be possible to provide an equal level of control through movement of the towline attachment point.

This study has shown that it is possible to stabilize the motions of a tow with lateral movement of the towline attachment point on the tow. Further research is necessary to better model the towed vessel dynamics and the command/actuator time delay. Nonlinear analysis of the

towed vessel dynamics will shed more light on the feasibility of the system. Integral control may be implemented to provide true pathkeeping ability, although simply stabilizing the response will improve safety.

APPENDIX

HINTS

Continuous Super-Block Est. Inputs Ext. Outputs
 CSYSTEM00 0 10

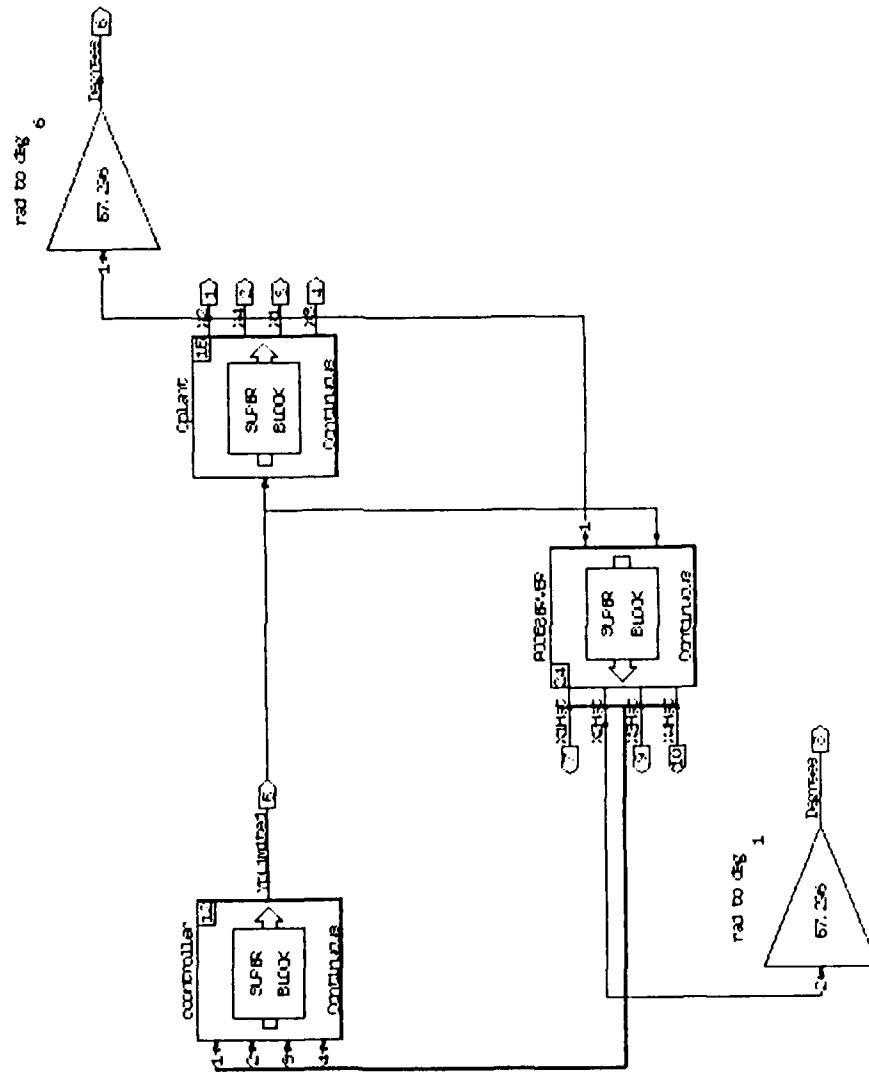

Figure 24. Matrix_x Plant/Compensator Block Diagram

HINTS	Continuous Super-Block Cplant	Ext. Inputs	Ext. Outputs
		1	4

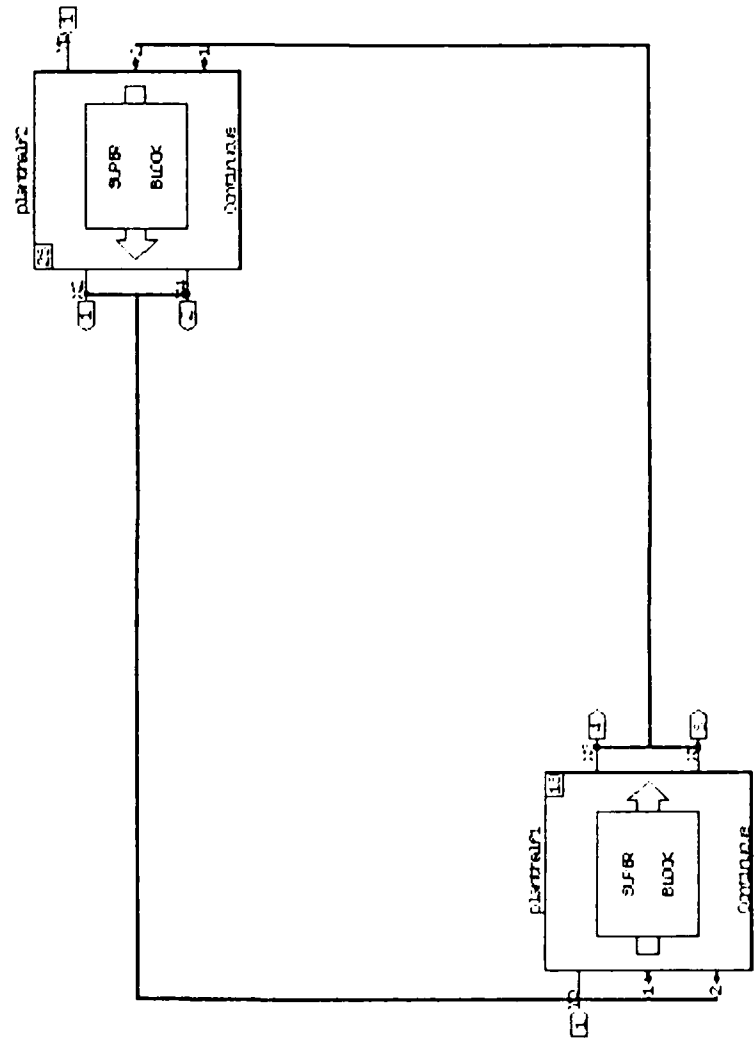

Figure 26. Matrix_x Plant (1 of 3) Block Diagram

HINTS

Continuous Super-Block
FOBSERVER2

Ext. Inputs	Ext. Outputs
2	1

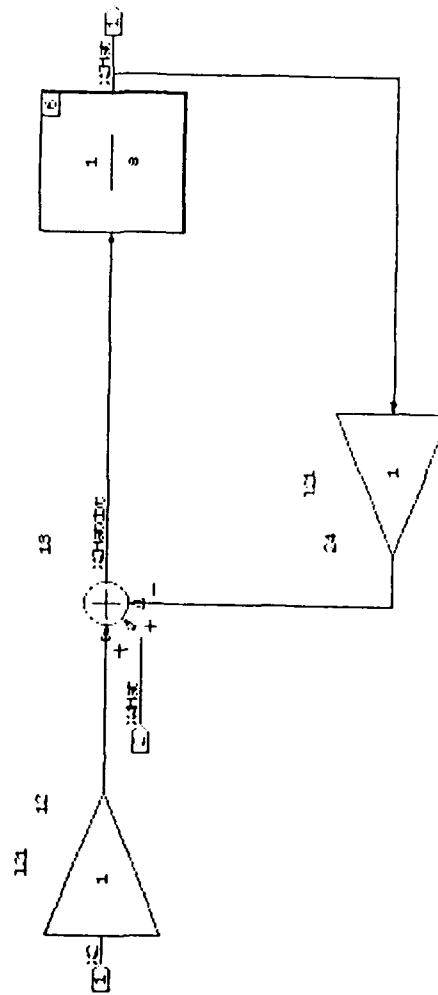

Figure 31. Matrix_x Observer (3 of 5) Block Diagram

HINTS

Continuous Super-Block
FOBSERVER3

Ext. Inputs 5
Ext. Outputs 1

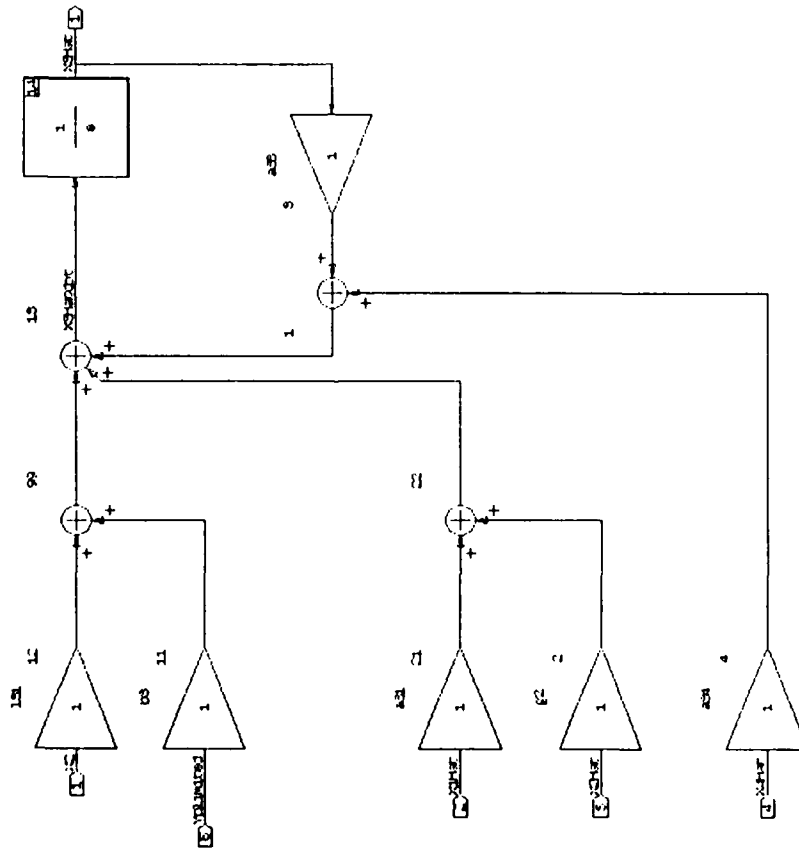

Figure 32. Matrix_x Observer (4 of 5) Block Diagram

HINTS
 Continuous Super-Block Ext. Inputs Ext. Outputs
 F0085EPVEK4 5 1

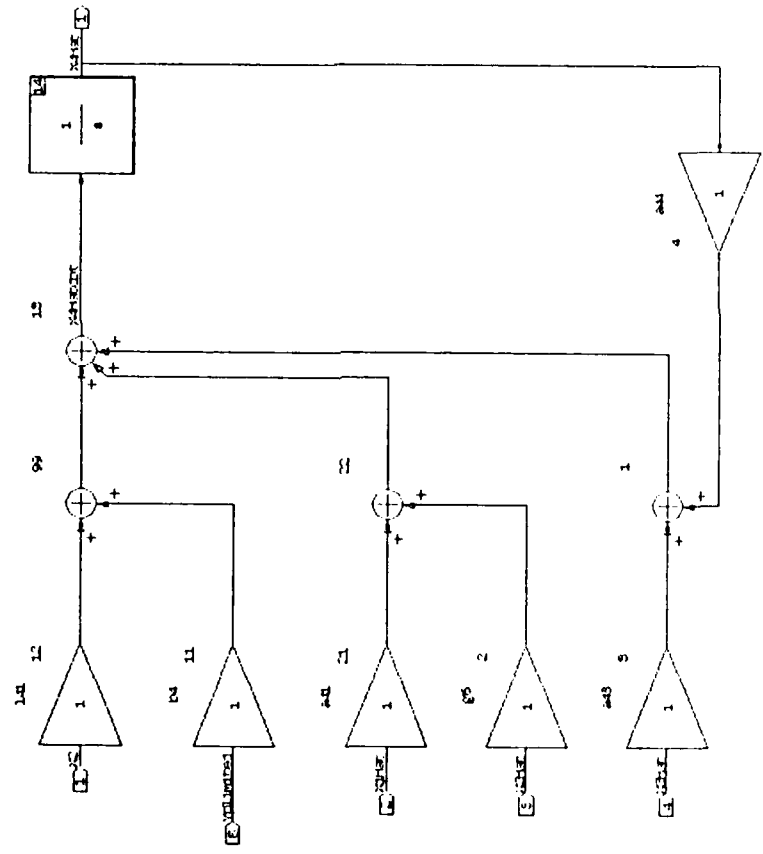

Figure 33. Matrix_x Observer (5 of 5) Block Diagram

HINTS

Continuous Super-Block Ext. Inputs 4 Ext. Outputs 1
 controller

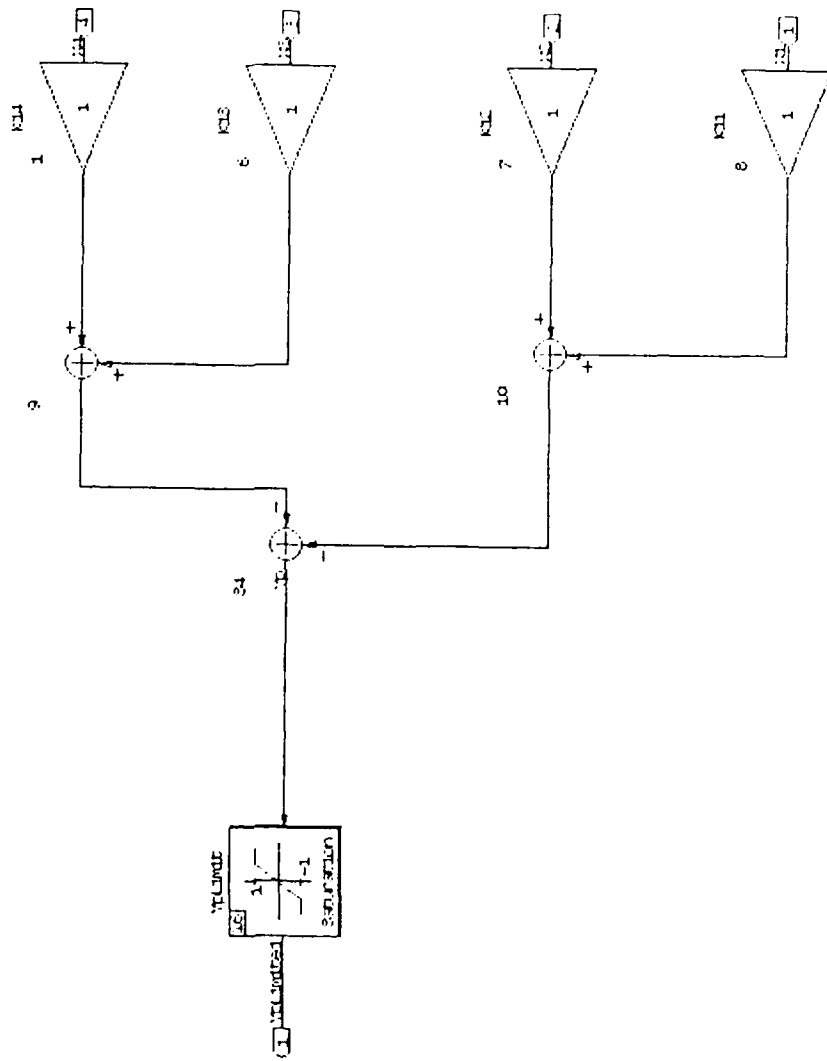

Figure 34. Matrix_x Controller Block Diagram

```

//***** cmarinerwol.x *****//
//
// Matrixx variables for use in designing //
// mariner towing classical control system. //
//
//The following are the non-dimensional hydrodynamic //
//coefficients, unless otherwise indicated. //
//
Xudot=-0.000444;
M=0.00888;
Yvdot=-0.00912;
Yv=-0.01434; -
Yrdot=0.0;
Yr=0.00456;
Ydel=0.0278;
Nvdot=0.0;
Nv=-0.0046; -
NrdotIz=-0.00115; //Nrdot-Iz//
Nr=-0.00296; -
Ndel=-0.0139;
//
//End list of hydrodynamic derivatives //
//
//The following statements define the A and B matrix elements.//
//
//***** Get critical parameters from user *****//
//
inquire LL //nondimensional towline length //
inquire Xp //nondimensional distance from CG fwd to towline...//
//attachment//
inquire T //nondimensional towline tension //
inquire YpSat //nondimensional max control//
//
U=1.0; //nondimensional ship velocity//
L=1.0; //nondimensional ship length//
//
D=NrdotIz*(Yvdot-M)-Nvdot*Yrdot;
//
//***** A matrix elements *****//
//
a13=1.0;
a24=1.0;
a31=(1/D)*(T/LL)*(NrdotIz-Xp*Yrdot);
a32=(1/D)*((Yv*U+T*(1+Xp/LL))*NrdotIz-Yrdot*(Nv*U+T*Xp*...
(1+Xp/LL)));
a33=(1/D)*(Nv*Yrdot-Yv*NrdotIz);
a34=(1/D)*((Yvdot*U-Yr)*NrdotIz-Yrdot*(Nvdot*U-Nr));
a41=(1/D)*(T/LL)*(Xp*(Yvdot-M)-Nvdot);
a42=(1/D)*((Yvdot-M)*(Nv*U+T*Xp*(1+Xp/LL))-Nvdot*...
(Yv*U+T*(1+Xp/LL)));
a43=(1/D)*(Nvdot*Yv-Nv*(Yvdot-M));
a44=(1/D)*(Nvdot*Yr-Nr*Yvdot+(Nr-Nvdot*U)*M);
//
//***** B matrix elements *****//
//
b3=(1/D)*T*(NrdotIz/LL-Yrdot*(1+Xp/LL));
b4=(1/D)*T*((Yvdot-M)*(1+Xp/LL)-Nvdot/LL);
//
//***** Matrix operations: design a controller *****//

```

Figure 35. Matrix_x Program Listing With Observer

```

//
A=[0,0,a13,0;0,0,0,a24;a31,a32,a33,a34;...
a41,a42,a43,a44];
//
//**** Check for stability of uncontrolled system ****
//**** (Open loop eigenvalues) ****
//
AEVALUES=eig(A);
//
//***** Define other matrices ****
//
B=[0.0;0.0;b3;b4];
C=[0,1,0,0]; //Note: assuming only yaw angle available//
DMatrix=[0];
SysMat=[A,B;C,DMatrix]; //System matrix: Xdot=AX+BU, Y=CX+DU//
//
//***** Check for controllability ****
//
NS=4; //Number of states//
[SC,NSC,T1]=cntrlable(SysMat,NS);
//
//SC=system matrix of controllable subsystem//
//NSC=number of states controllable//
//T1=transformation between original and new space//
//
//***** Get desired closed-loop poles from user ****
//
inquire Poles
//
//***** Pole place to find the K row vector ****
//
K=poleplace(A,B,Poles);
//
//
K11=K(1,1);
K12=K(1,2);
K13=K(1,3);
K14=K(1,4);
//
//***** Check for observability ****
//
[SOBS,NSOBS,T2]=observable(SysMat,NS);
//
//SOBS=observable subsystem matrix//
//NSOBS=number of states observable//
//T2=transformation between original and new space//
//
//***** Design full order observer ****
//
//** observer equation: Xhatdot=A*Xhat+B*u+L*(y-C*Xhat) **
//
//***** Get observer poles from user ****
//
inquire obspoles
LT=poleplace(A',C',OBSPOLES);
//
//LT=L transpose//
//OBSPOLES=observer poles//
//
//***** Define L matrix elements ****

```

```

//
l11=LT(1,1);
l21=LT(1,2);
l31=LT(1,3);
l41=LT(1,4);
//
//*** Define gains for use in simulation *****//
//
G2=a32-l31;
G6=a42-l41;
//
// ***** SIMULATION *****//
//
sim('analyze/csystemwo/');
//
inquire tsim //simulation duration in nondimensional time//
inquire tstep//simulation time step, nondimensional//
//
TS=[0:tstep:tsim]'; //the "time" vector for simulation//
y=sim(TS);
//
// ***** PLOTTING *****//
//
plot(TS,Y(:,[3 7]),'upper left xlabel/T/ ylabel/Y Yhat/TITLE/...
Poles=[-0.5,-0.51,-0.52,-0.53]//')
plot(TS,Y(:,5),'upper right xlabel/T/ ylabel/Yp/TITLE/...
ObsPoles=[-2.5,-2.55,-2.60,-2.65]//')
plot(TS,Y(:,[4 9]),'lower left xlabel/T/ ylabel/v vhat...
/TITLE/T=0.001 Xp=0.5 LL=2.5//')
plot(TS,Y(:,[6 8]),'lower right xlabel/T/ ylabel/Psi Psihat...
/TITLE/Mariner//')

```

```

//***** cmariner1.x *****//
//
// Matrix variables for use in designing
// mariner towing classical control system.
//
//The following are the non-dimensional hydrodynamic
//coefficients, unless otherwise indicated.
//
Xudot=-0.000444;
M=0.00888;
Yvdot=-0.00912;
Yv=-0.01434;
Yrdot=0.0;
Yr=0.00456;
Ydel=0.0278;
Nvdot=0.0;
Nv=-0.0046;
NrdotIz=-0.00115; //Nrdot-Iz//
Nr=-0.00296;
Ndel=-0.0139;
//
//End list of hydrodynamic derivatives
//
//
//The following statements define the A and B matrix elements.//
//
//***** Get critical parameters from user *****//
//
inquire LL //nondimensional towline length
inquire Xp //nondimensional distance from CG fwd to towline...//
//attachment//
inquire T //nondimensional towline tension
inquire YpSat //nondimensional max control//
//
U=1.0; //nondimensional ship velocity//
L=1.0; //nondimensional ship length//
//
D=NrdotIz*(Yvdot-M)-Nvdot*Yrdot;
//
//***** A matrix elements *****//
//
a13=1.0;
a24=1.0;
a31=(1/D)*(T/LL)*(NrdotIz-Xp*Yrdot);
a32=(1/D)*((Yv*U+T*(1+Xp/LL))*NrdotIz-Yrdot*(Nv*U+T*Xp*...
(1+Xp/LL));
a33=(1/D)*(Nv*Yrdot-Yv*NrdotIz);
a34=(1/D)*((Yvdot*U-Yr)*NrdotIz-Yrdot*(Nvdot*U-Nr));
a41=(1/D)*(T/LL)*(Xp*(Yvdot-M)-Nvdot);
a42=(1/D)*((Yvdot-M)*(Nv*U+T*Xp*(1+Xp/LL))-Nvdot*...
(Yv*U+T*(1+Xp/LL)));
a43=(1/D)*(Nvdot*Yv-Nv*(Yvdot-M));
a44=(1/D)*(Nvdot*Yr-Nr*Yvdot+(Nr-Nvdot*U)*M);
//
//***** B matrix elements *****//
//
b3=(1/D)*T*(NrdotIz/LL-Yrdot*(1+Xp/LL));
b4=(1/D)*T*((Yvdot-M)*(1+Xp/LL)-Nvdot/LL);
//
//***** Matrix operations: design a controller *****//

```

Figure 36. Matrix_x Program Listing Without Observer

```

//
A=[0,0,a13,0;0,0,0,a24;a31,a32,a33,a34;...
a41,a42,a43,a44];
//
//**** Check for stability of uncontrolled system ****//
//**** (Open loop eigenvalues) ****//
//
AEVALUES=eig(A);
//
//***** Define other matrices ****//
//
B=[0.0;0.0;b3;b4];
C=[0,1,0,0]; //Note: assuming only yaw angle available//
DMatrix=[0];
SysMat=[A,B;C,DMatrix]; //System matrix: Xdot=AX+BU, Y=CX+DU//
//
//***** Check for controllability ****//
//
NS=4; //Number of states//
[SC,NSC,Tl]=cntrlable(SysMat,NS);
//
//SC=system matrix of controllable subsystem//
//NSC=number of states controllable//
//Tl=transformation between original and new space//
//
//***** Get desired closed-loop poles from user ****//
//
inquire Poles
//
//***** Pole place to find the K row vector ****//
//
K=poleplace(A,B,Poles);
//
//
K11=K(1,1);
K12=K(1,2);
K13=K(1,3);
K14=K(1,4);
//
// ***** SIMULATION ****//
//
sim('analyze/csystem/');
//
inquire tsim //simulation duration in nondimensional time//
inquire tstep//simulation time step, nondimensional//
//
TS=[0:tstep:tsim]'; //the "time" vector for simulation//
y=sim(TS);
//
// ***** PLOTTING ****//
//
plot(TS,Y(:,3),'upper left xlabel/T/ ylabel/Y/TITLE/...
Poles=[-0.5,-0.51,-0.52,-0.53]')
plot(TS,Y(:,5),'upper right xlabel/T/ ylabel/Yp/TITLE/...
No observer/')
plot(TS,Y(:,4),'lower left xlabel/T/ ylabel/v...
/TITLE/T=0.001 Xp=0.5 LL=2.5/')
plot(TS,Y(:,1),'lower right xlabel/T/ ylabel/Psi...
/TITLE/Mariner/')

```

TABLE 1

TOWED VESSEL DATA

Property	Vessel		
	Barge	Tanker	Mariner
LBP, ft	191.56	1066.3	528
$X'_{\dot{u}}$	-0.00136	-0.0009	-0.0004444
m'	0.170	0.0181	0.00888
$Y'_{\dot{v}}$	-0.01383	-0.0171	-0.00912
$Y'_{\dot{v}}$	-0.0153	-0.0261	-0.01434
$Y'_{\dot{\psi}}$	0	0	0
$Y'_{\dot{\psi}}$	0.00238	0.00365	0.00456
$N'_{\dot{v}}$	0	0	0
$N'_{\dot{v}}$	-0.007285	-0.0105	-0.0046
$I'_{z} - N'_{\dot{\psi}}$	0.00188	0.00222	0.00115
$N'_{\dot{\psi}}$	-0.00128	-0.0048	-0.00296

TABLE 2

NONDIMENSIONAL TERMS

$m' = m/m_r$	$Y'_V = Y_V / (m_r u_o / L)$
$u' = u/u_o$	$Y'_{\dot{V}} = Y_{\dot{V}} / m_r$
$v' = v/u_o$	$Y'_R = Y_{\dot{\psi}} = Y_{\ddot{\psi}} / (m_r u_o)$
$\dot{u}' = \dot{u} / (u_o^2 - L)$	$Y'_{\dot{R}} = Y_{\dot{\psi}} = Y_{\ddot{\psi}} / (m_r L)$
$\dot{v}' = \dot{v} / (u_o^2 - L)$	$N'_V = N_V / (m_r u_o)$
$t' = t / (L/u_o)$ (time)	$N'_{\dot{V}} = N_{\dot{V}} / (m_r L)$
$I'_Z = I_Z / (m_r L^2)$	$N'_R = N_{\dot{\psi}} = N_{\ddot{\psi}} / (m_r u_o L)$
$r' = \dot{\psi}' = \dot{\psi} / (u_o / L)$	$N'_{\dot{R}} = N_{\dot{\psi}} = N_{\ddot{\psi}} / (m_r L^2)$
$\dot{r}' = \ddot{\psi}' = \ddot{\psi} / (u_o^2 L^2)$	$T' = T / (m_r u_o^2 / L)$ (Tension)
$x'_g = x_g / L$	$l' = l / L$
$y'_g = y_g / L$	$x'_p = x_p / L$
$X'_u = X_u / (m_r u_o / L)$	$y'_p = y_p / L$
$X'_{\dot{u}} = X_{\dot{u}} / m_r$	

LIST OF REFERENCES

1. Bernitsas, M.M. and Kekridis, N.S. "Simulation and Stability of Ship Towing", International Shipbuilding Progress, v.32, 1985.
2. Papoulias, F.A., "A Qualitative and Quantitative Study of Steady-State Response of Towed Floating Bodies", Dynamics and Stability of Systems, v.3, 1988.
3. Kolthoff, D.L., "Parametric Study of the Dynamic Stability of Towed Ships", Master's Thesis, Naval Postgraduate School, Monterey, CA, December, 1989.
4. Krikelis, N.J. and Kavouras, D., "Dynamic Performance of Towed Vessels Employing Nonlinear Rudder Control Under Adverse Weather Conditions", International Shipbuilding Progress, v.33, 1986.

INITIAL DISTRIBUTION LIST

1. Defense Technical Information Center 2
Cameron Station
Alexandria, VA 22304-6145
2. Library, Code 0142 2
Naval Postgraduate School
Monterey, CA 93943-5002
3. LT J.B. Newell 1
32 Christensen Ave.
Salinas, CA 93906
4. Superintendent 1
Naval Postgraduate School
Code 34
Monterey, CA 93943
5. F.A. Papoulias 3
Naval Postgraduate School
Code 69 Pa
Monterey, CA 93943
6. Chairman, Department of Mechanical Engineering 1
Naval Postgraduate School
Code ME
Monterey, CA 93943
7. John Moschopoulos 1
Naval Sea Systems Command
Code 56z4
Washington, DC 20362-5101