

DTIC FILE COPY

NUSC Technical Document 8347
17 August 1988

①

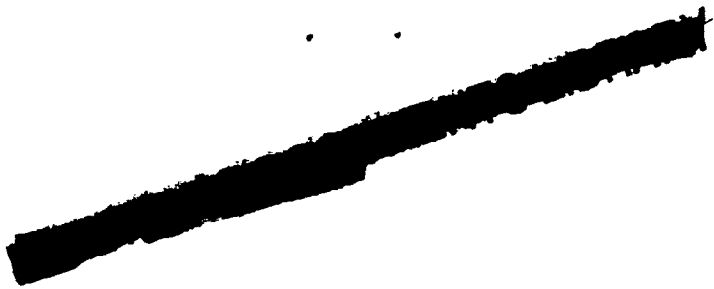

AD-A227 874

Volume Scattering Measurements Using Parametric Sonar

A Paper Presented at the 115th Meeting
of the Acoustical Society of America,
16-20 May 1988, Seattle, Washington

James M. Syck
Charles L. Brown, Jr.
Environmental and Tactical
Support Department

DTIC
ELECTE
OCT 22 1990
S E D
Co



Naval Underwater Systems Center
Newport, Rhode Island / New London, Connecticut

Approved for public release; distribution is unlimited

90 10 18 083

PREFACE

The work reported here was done under various projects. Support for preparation of the document was completed under the high frequency program, NUSC Project No. A67001, John Chester, principal investigator, Dr. Robert Farwell, NORDA, Code 240, Program Manager.

REVIEWED AND APPROVED: 17 August 1988



L. SOLOMON
ENVIRONMENTAL AND TACTICAL
SUPPORT DEPARTMENT

REPORT DOCUMENTATION PAGE

1a. REPORT SECURITY CLASSIFICATION UNCLASSIFIED		1b. RESTRICTIVE MARKINGS	
2a. SECURITY CLASSIFICATION AUTHORITY		3. DISTRIBUTION / AVAILABILITY OF REPORT Approved for public release; distribution is unlimited.	
2b. DECLASSIFICATION / DOWNGRADING SCHEDULE		5. MONITORING ORGANIZATION REPORT NUMBER(S)	
4. PERFORMING ORGANIZATION REPORT NUMBER(S) TD 8347		7a. NAME OF MONITORING ORGANIZATION	
6a. NAME OF PERFORMING ORGANIZATION Naval Underwater Systems Center	6b. OFFICE SYMBOL (if applicable) 3112	7b. ADDRESS (City, State, and ZIP Code)	
6c. ADDRESS (City, State, and ZIP Code) New London Laboratory New London, CT 06320		9. PROCUREMENT INSTRUMENT IDENTIFICATION NUMBER	
8a. NAME OF FUNDING / SPONSORING ORGANIZATION Naval Underwater Systems Cntr	8b. OFFICE SYMBOL (if applicable)	10. SOURCE OF FUNDING NUMBERS	
8c. ADDRESS (City, State, and ZIP Code) New London Laboratory New London, CT 06320		PROGRAM ELEMENT NO. 62435N	PROJECT NO. A67001
		TASK NO. RJ35V11	WORK UNIT ACCESSION NO. TD 0831
11. TITLE (Include Security Classification) VOLUME SCATTERING MEASUREMENTS USING PARAMETRIC SONAR			
12. PERSONAL AUTHOR(S) James M. Syck and Charles L. Brown, Jr.			
13a. TYPE OF REPORT	13b. TIME COVERED FROM TO	14. DATE OF REPORT (Year, Month, Day) 1988 August 17	15. PAGE COUNT
16. SUPPLEMENTARY NOTATION			
17. COSATI CODES		18. SUBJECT TERMS (Continue on reverse if necessary and identify by block number)	
FIELD	GROUP	SUB-GROUP	
			Volume Scattering AUTEK
			High Frequency Gulf of Mexico
			Parametric Sonar Deep Scattering Layer
19. ABSTRACT (Continue on reverse if necessary and identify by block number)			
<p>A parametric sonar has been used to measure volume scattering strength at a number of ocean locations. The narrow beamwidth and absence of sidelobes of the parametric sonar make it an ideal tool for measuring volume scattering strength as a function of depth and frequency. The resolution of this device is such that in some circumstances individual scatterers can be identified. An example of such a situation is presented. The parametric sonar system is described. Additional sets of examples from nearshore and off-shore areas are presented for both day and night conditions and for migration periods. (R.L.)</p>			
20. DISTRIBUTION / AVAILABILITY OF ABSTRACT <input type="checkbox"/> UNCLASSIFIED/UNLIMITED <input checked="" type="checkbox"/> SAME AS RPT. <input type="checkbox"/> DTIC USERS		21. ABSTRACT SECURITY CLASSIFICATION UNCLASSIFIED	
22a. NAME OF RESPONSIBLE INDIVIDUAL James Syck		22b. TELEPHONE (Include Area Code) (203) 440-5999	22c. OFFICE SYMBOL 3112

VOLUME SCATTERING MEASUREMENTS
USING PARAMETRIC SONAR

INTRODUCTION

This document reports volume scattering measurements in the frequency range 20-27 kHz. First, the hardware is described and then examples of the data obtained are given. A parametric sonar is used for these measurements because it has a narrow beamwidth (narrow enough in some cases to obtain reflections from individual scatterers). Additional virtues of the parametric sonar are that it has practically no sidelobes to confuse the interpretation of the data and permits easy frequency changing.

As with many current systems, an associated sea-going computer provides calibrated output in real time and takes into account system parameters such as transmitted and received beam patterns.

Accession For	
NTIS GRA&I	<input checked="" type="checkbox"/>
DTIC TAB	<input checked="" type="checkbox"/>
Unannounced	<input type="checkbox"/>
Justification	
By _____	
Distribution/	
Availability Codes	
Dist	Avail and/or Special
A-1	



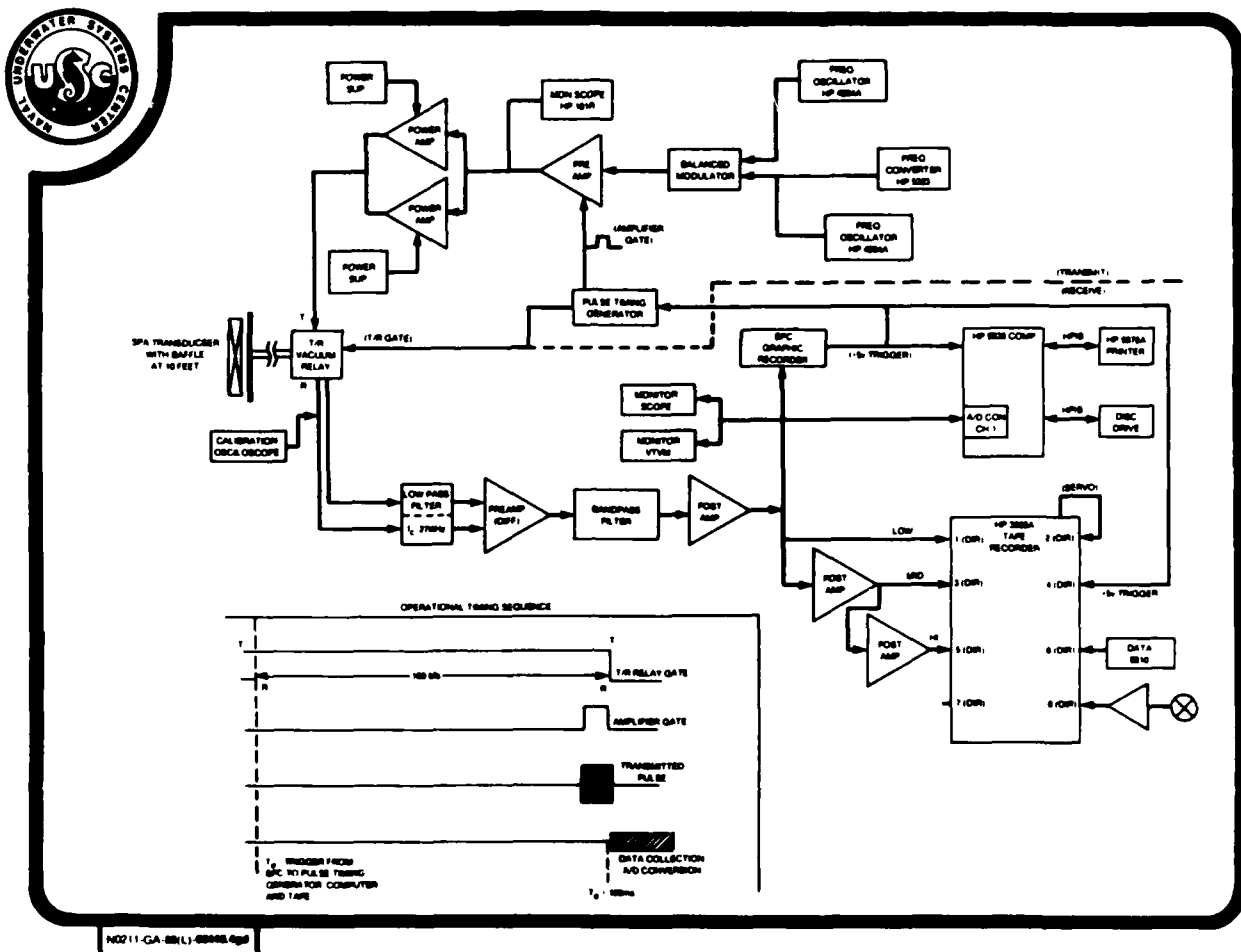

VIEWGRAPH 1

This viewgraph is a block diagram of the sonar system. Starting in the upper right corner, two frequencies are generated, mixed, amplified and, on the left side, the signals are transmitted by the parametric transducer. The power levels of the transmitted signals are quite high, and this causes a nonlinear interaction in the water which results in a very narrow acoustic beam at the difference frequency. A description of this process may be found in reference (1).

The receive portion of the system uses the same transducer as a receiver. The signal is filtered, amplified, and sent to three locations:

1. a graphic recorder,
2. an analog tape recorder, and
3. a computer.

The computer, using a 12 bit AD, converts the signal from analog to digital, and the sonar equation is solved so that the data is presented as corrected scattering strength. The result is then displayed on a color graphics terminal, a hard copy is printed out, and the data is stored on disk.



**PARAMETRIC BEAM PATTERN
EDO ARRAY $f = 20$ kHz**

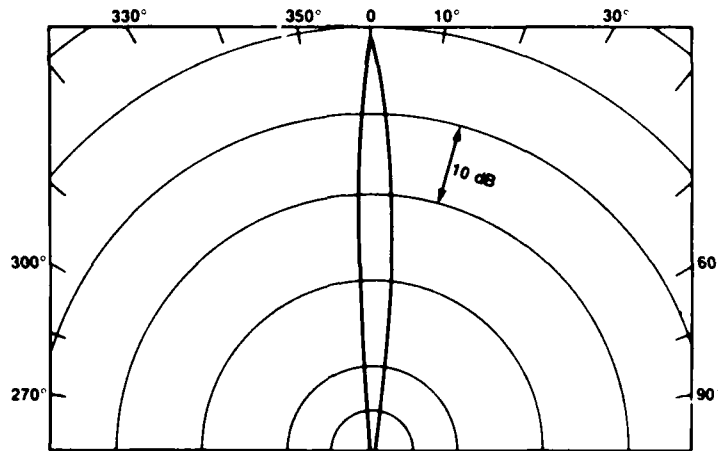

VIEWGRAPH 2

This viewgraph shows the parametric beam pattern. The beamwidth of this sonar is 2.5° at the 3dB down points. The sidelobes are greatly reduced in comparison to a conventional transducer. Here there are none shown because they are down more than 40 dB, relative to the main lobe, and are hard to represent on the scale of this plot.

The source level of this device is a function of frequency: at 20 kHz it is 219 dB, at 27 kHz, it is 225 dB.



VIEWGRAPH 3

This viewgraph is a photograph of the transducer as it is about to be lowered into the water. The disk-shaped transducer is composed of 240 elements. There is a 3/4-in. baffle plate of rubber above the transducer to absorb energy from above. The transducer is lowered to a depth of 10 ft. As can be seen in the photograph, there will be a tendency for some motion of the transducer when the ship rolls. The receive beamwidth of 8° is wider than the transmit beamwidth and compensates for the transducer motion.

TOTO 9/82 65 Frequency = 20 kHz Beamwidth = 1.7° Pulse Width = 5 ms

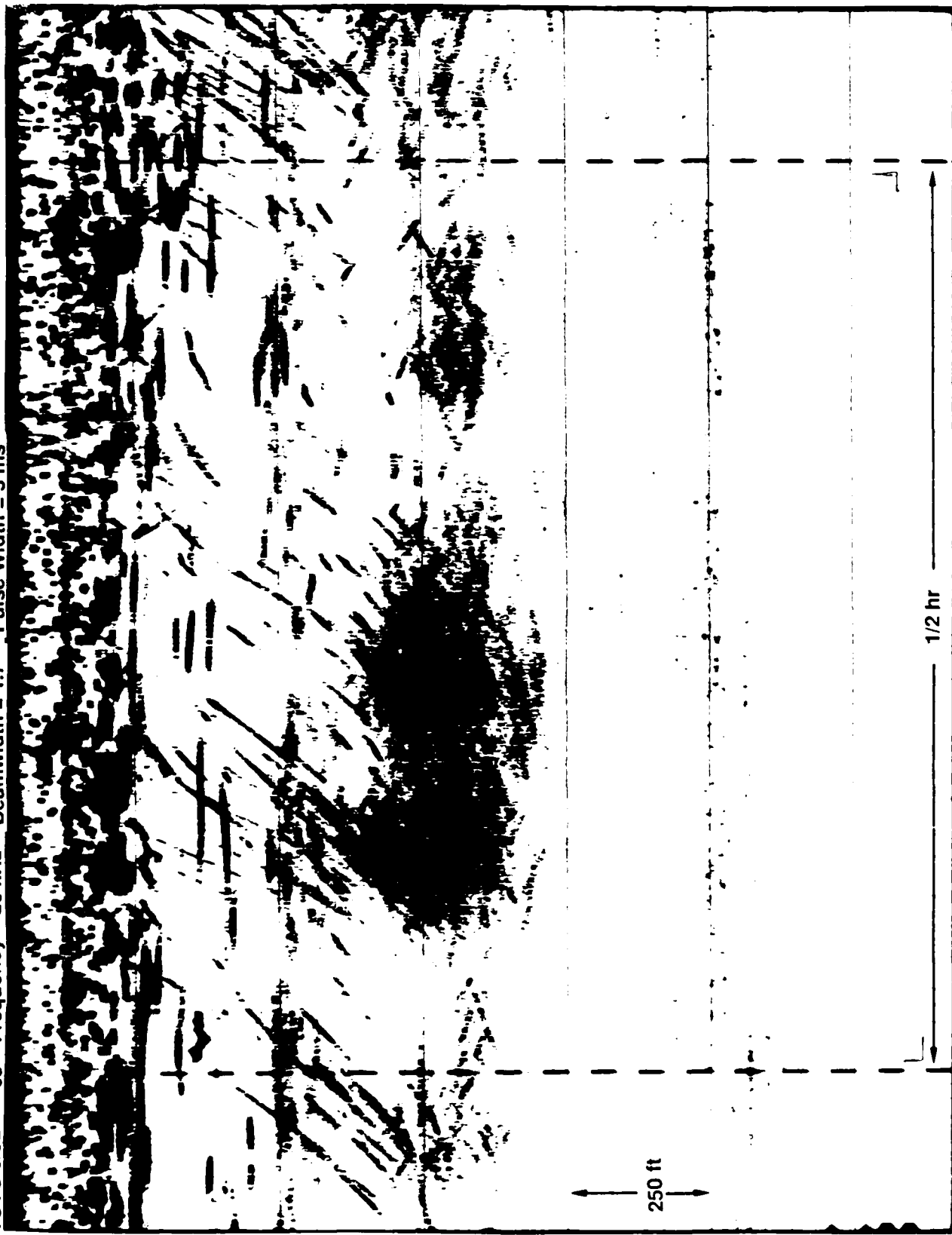

250 ft

1/2 hr

1600

1630

Drift < 1/2 kt

VIEWGRAPH 4

This viewgraph shows the output of the graphic recorder. This form of output is most familiar to workers in the field and forms the point of departure for the discussion that follows. The qualitative behavior of the scattering phenomenon is best shown in this kind of display, but misleading quantitative impressions result from beam spreading and attenuation effects that are not accounted for.

These data were taken during the upward migration of scatterers in the evening. We see clouds of scatterers that remain at a fixed depth as well as individual scatterers that enter the sonar beam and then pass out of it. The time interval between the vertical dashed lines is one half hour. The depth covered by the viewgraph is 1700 ft. The frequency was 20 kHz, and the pulse length was 5 ms.

The following data presents 20 ping averages. The nominal ping rate was once per minute, so the data in succeeding viewgraphs represent averages over roughly 2/3 of the time interval shown on this viewgraph.



VOLUME SCATTERING STRENGTH-GULF OF MEXICO; FEB 1987
COMPARISON OF DAY AND NIGHT LEVELS AT THE DEEP SITE FOR 25 KHZ

DEEP DAY 151129 ————— DEEP NIGHT 142334 - - - - -

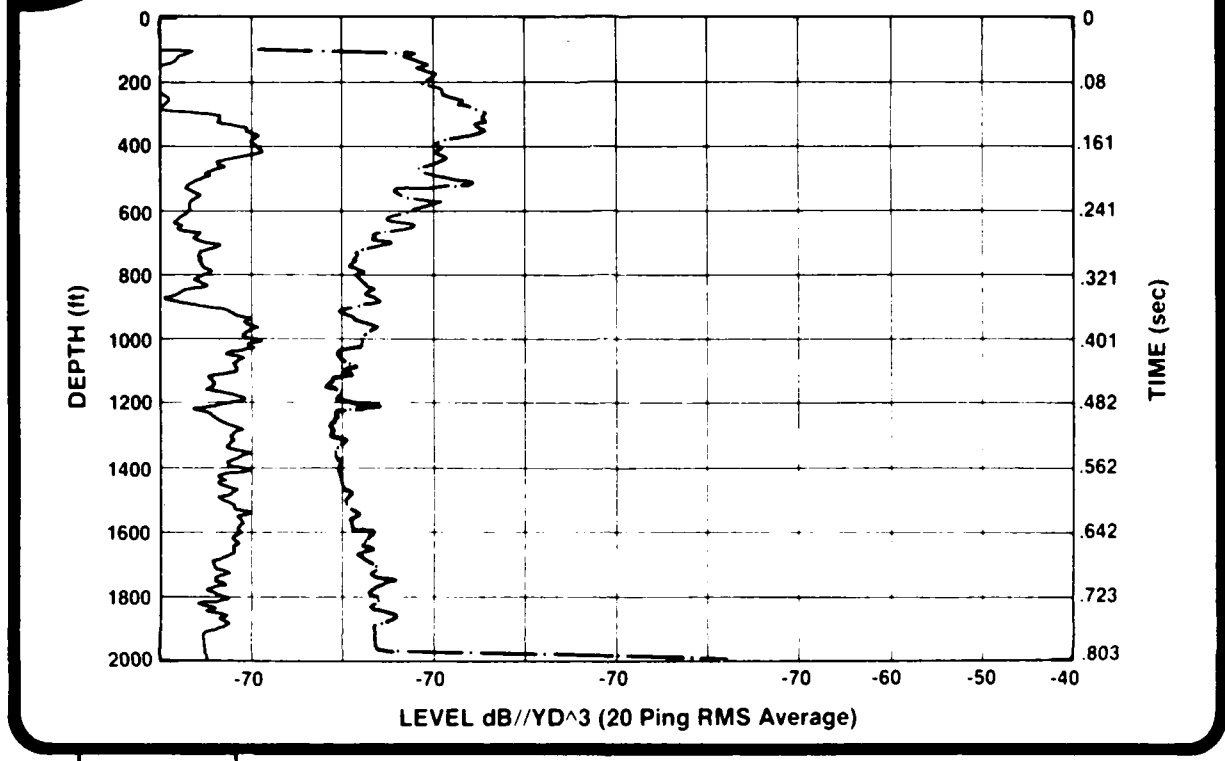

VIEWGRAPH 5

This viewgraph is an example of some data obtained in the Gulf of Mexico in February of 1987.² We have many such plots, and this one was chosen to point out some common features. This measurement was taken at 25 kHz, and the data presented are averages over 20 pings. Noon and midnight profiles are presented. The night plot is displaced to the right by 20 dB for clarity.

During the day, we see several layers with volume scattering strength of -70 dB. At night, the deep layers are relatively impoverished, and the layer at 300 ft increases scattering strength to -65 dB.

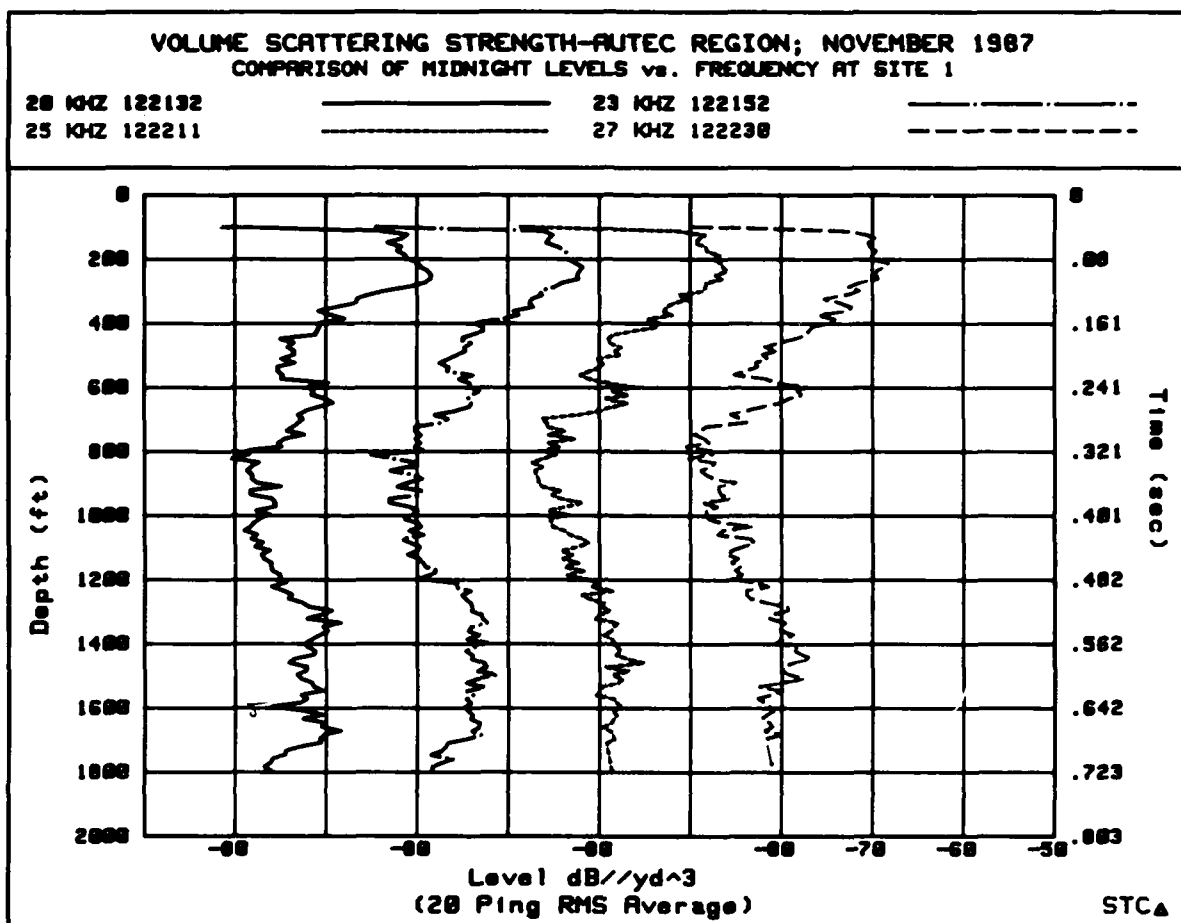

VIEWGRAPH 6

This viewgraph shows how scattering strength varies over the frequency range of 20 to 27 kHz. All these data were taken around midnight from the Tongue of the Ocean in the Bahamas.³ The shapes of the curves are similar, but there is a decrease in the level of scattering strength of about 10 dB as frequency increases from 20 to 27 kHz. This is true at all depths. Also, we note that the layer at 600 ft is better defined in the 27 kHz data than it is in the 20 kHz data.

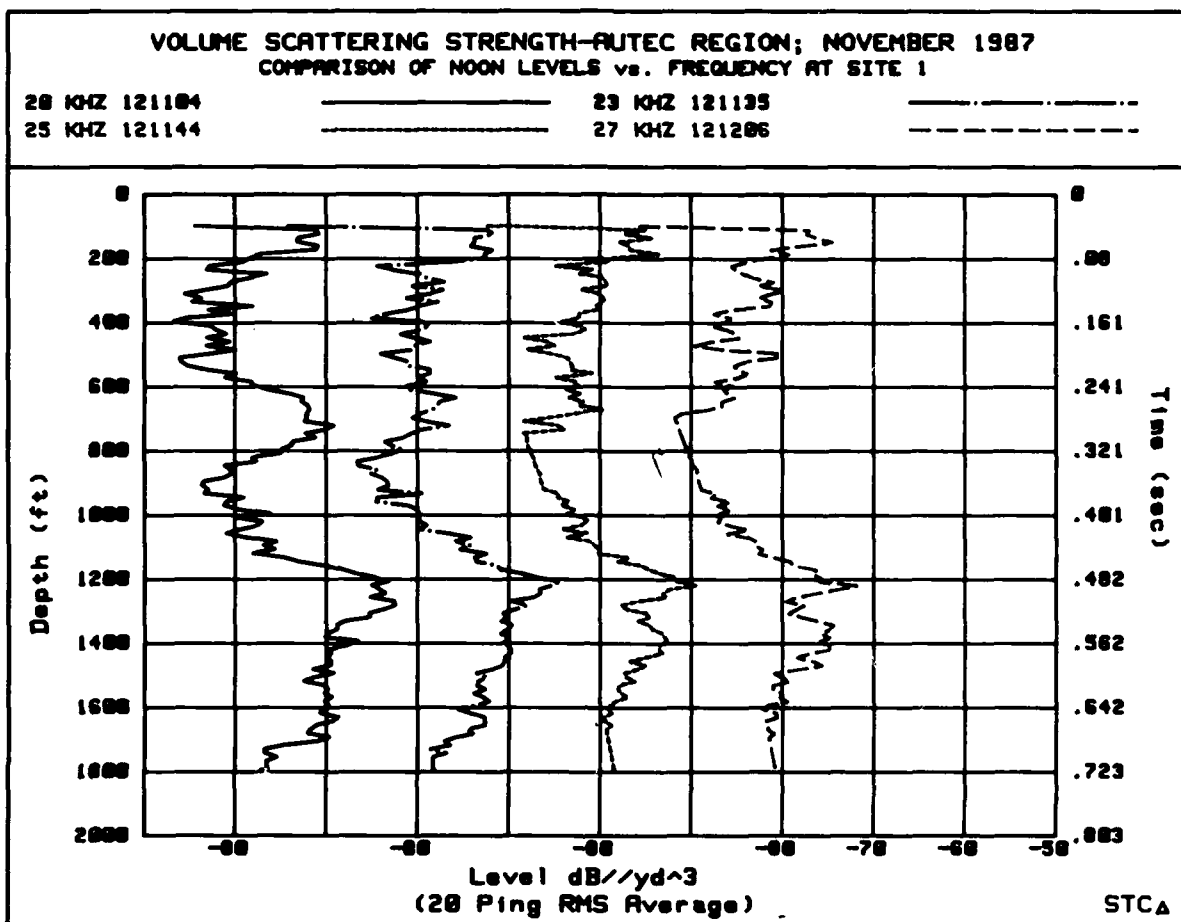

VIEWGRAPH 7

These data were taken at the same location as the previous data. The difference here is that the data were taken around noon. The same frequency dependence still holds; there is a decrease in scattering strength with increasing frequency. The highest values of scattering strength are found near a depth of 1,200 ft instead of near the surface as was the case previously.

NUSC

CONCLUSIONS

- **PARAMETRIC SONAR PROVIDES IDEAL PROBE FOR SCATTERING STRENGTH MEASUREMENTS**
- **DATA SHOW WEAK FREQUENCY DEPENDENCE IN THE 20 TO 27 KHZ REGIME**
- **DETAILED STRUCTURE OF PROFILE RELATED TO BIOLOGICAL PATCHINESS**
- **DAY/NIGHT DIFFERENCES ARE AS EXPECTED FROM PREVIOUS MEASUREMENTS**

NO211-GA-88(N)-576.1A

VIEWGRAPH 8

We conclude that the parametric sonar is an ideal probe for scattering strength measurements, because it has relatively high source level, narrow beamwidth, and practically no sidelobes, and permits easy frequency changing.

There is a frequency dependence of the backscattering strength that amounts to a 10 dB decrease from 20 to 27 kHz in the Tongue of the Ocean.

Detailed structure of the profile is related to biological patchiness. In this presentation, we have removed some of this by performing averages over 20 pings.

Observations of the day/night scattering strength profile are as expected from previous measurements.

REFERENCES

1. C. S. Clay and H. Medwin, Acoustical Oceanography, Wiley-Interscience, New York, 1977.
2. Structured Technology Corporation, Technical Report, "Volume Scattering Characteristics in the Gulf of Mexico," 22 February 1988.
3. Structured Technology Corporation, Technical Report, "Volume Scattering Characteristics in the AUTEK Region," 14 March 1988.

INITIAL DISTRIBUTION LIST

Addressee	No. of copies
Dr. Robert Farwell, NORDA, Code 240	4
DTIC	2
CNA	1