

# LOAN DOCUMENT

PHOTOGRAPH THIS SHEET

AD-A228 151

DTIC ACCESSION NUMBER

TR FILE COPY

LEVEL

INVENTORY

**WRDC-TR-90 8023**  
DOCUMENT IDENTIFICATION  
**NOV 1990**

### DISTRIBUTION STATEMENT A

Approved for public release;  
Distribution Unlimited

### DISTRIBUTION STATEMENT

ACCESSION FOR	
NTIS	GRA&I
DTIC	TRAC
UNANNOUNCED	<input type="checkbox"/>
JUSTIFICATION	
BY	
DISTRIBUTION/	
AVAILABILITY CODES	
DISTRIBUTION	AVAILABILITY AND/OR SPECIAL
<b>A-1</b>	

DISTRIBUTION STAMP

**DTIC**  
**ELECTE**  
OCT 25 1990  
**S E D**

DATE ACCESSIONED

DATE RETURNED

DATE RETURNED

90 - 29

DATE RECEIVED IN DTIC

REGISTERED OR CERTIFIED NUMBER

REGISTERED OR CERTIFIED NUMBER

PHOTOGRAPH THIS SHEET AND RETURN TO DTIC-FDAC

H  
A  
N  
D  
L  
E  
W  
I  
T  
H  
C  
A  
R  
E

AD-A228 151

WRDC-TR-90-8023

GEOMETRIC MODELING APPLICATIONS INTERFACE PROGRAM

SYSTEM TRANSLATOR USER'S MANUAL

United Technologies Corporation  
Pratt and Whitney  
Government Products Division  
P.O. Box 9600  
West Palm Beach, Florida 33410-9600

NOVEMBER 1990

Final Report For Period August 1985 - July 1988

Approved for public release; distribution is unlimited

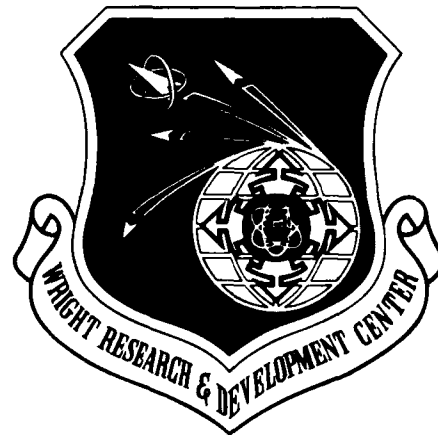

MANUFACTURING TECHNOLOGY DIRECTORATE  
WRIGHT RESEARCH AND DEVELOPMENT CENTER  
AIR FORCE SYSTEMS COMMAND  
WRIGHT-PATTERSON AIR FORCE BASE, OHIO 45433-6533

NOTICE

When Government drawings, specifications, or other data are used for any purpose other than in connection with a definitely Government-related procurement, the United States Government incurs no responsibility or any obligation whatsoever. The fact that the government may have formulated or in any way supplied the said drawings, specifications, or other data, is not to be regarded by implication, or otherwise in any manner construed, as licensing the holder, or any other person or corporation; or as conveying any rights or permission to manufacture, use, or sell any patented invention that may in any way be related thereto.

This report is releasable to the National Technical Information Service (NTIS). At NTIS, it will be available to the general public, including foreign nations.

This technical report has been reviewed and is approved for publication.



Charles Gilman  
Project Manager

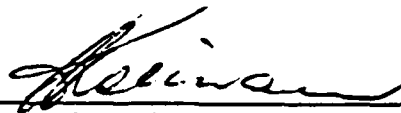

Walter H. Reimann, Chief  
Computer-Integrated Mfg. Branch

FOR THE COMMANDER

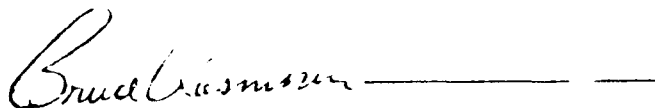

BRUCE A. RASMUSSEN  
Chief, Integration Technology Division  
Manufacturing Technology Directorate

If your address has changed, if you wish to be removed from our mailing list, or if the addressee is no longer employed by your organization please notify WRDC/MTT, WPAFB, OH 45433-6533 to help us maintain a current mailing list.

Copies of this report should not be returned unless return is required by security considerations, contractual obligations, or notice on a specific document.

REPORT DOCUMENTATION PAGE

1a. REPORT SECURITY CLASSIFICATION Unclassified		1b. RESTRICTIVE MARKINGS	
2a. SECURITY CLASSIFICATION AUTHORITY		3. DISTRIBUTION/AVAILABILITY OF REPORT Approved for public release; distribution is unlimited	
2b. DECLASSIFICATION/DOWNGRADING SCHEDULE			
4. PERFORMING ORGANIZATION REPORT NUMBER(S) FR 20463		5. MONITORING ORGANIZATION REPORT NUMBER(S) WRDC-TR-90-8023	
6a. NAME OF PERFORMING ORGANIZATION United Technologies Corporation Pratt & Whitney Government Products Division	6b. OFFICE SYMBOL (If applicable)  (P&W)	7a. NAME OF MONITORING ORGANIZATION Wright Research and Development Center Manufacturing Technology Directorate (WRDC/MTI)	
6c. ADDRESS (City, State and ZIP Code) P.O. Box 9600 West Palm Beach, Florida 33410-9600		7b. ADDRESS (City, State and ZIP Code) Wright-Patterson AFB OH 45433-6533	
8a. NAME OF FUNDING/SPONSORING ORGANIZATION	8b. OFFICE SYMBOL (If applicable)	9. PROCUREMENT INSTRUMENT IDENTIFICATION NUMBER  F33615-85-C-5122	
8c. ADDRESS (City, State and ZIP Code)		10. SOURCE OF FUNDING NOS.	
		PROGRAM ELEMENT NO.	PROJECT NO.
		TASK NO.	WORK UNIT NO.
11. TITLE (Include Security Classification) GEOMETRIC MODELING APPLICATIONS INTERFACE PROGRAM		78011F	MTP1 06 74
12. PERSONAL AUTHOR(S) R. Helldoerfer, C. Van Wie, D. Emmerson			
13a. TYPE OF REPORT Final	13b. TIME COVERED FROM 1 Aug 85 TO 31 Jul 88	14. DATE OF REPORT (Yr., Mo., Day) November 1990	15. PAGE COUNT 42
16. SUPPLEMENTARY NOTATION			
17. COSATI CODES		18. SUBJECT TERMS (Continue on reverse if necessary and identify by block number)	
FIELD	GROUP	Geometric Modeling Applications Interface Program, Product Definition Data Interface, Turbine Blades and Disks	
19. ABSTRACT (Continue on reverse if necessary and identify by block number)			
<p>This User Manual provides a guide for the System Translator component of the software developed under the Computer Integrated Manufacturing program known as GMAP (Geometric Modeling Applications Interface Program), U.S. Air Force Contract F33615-85-C-5122. It includes the capabilities of the System Translator's major components, the preprocessor and postprocessor.</p>			
20. DISTRIBUTION/AVAILABILITY OF ABSTRACT UNCLASSIFIED/UNLIMITED <input checked="" type="checkbox"/> SAME AS RPT. <input type="checkbox"/> DTIC USERS <input type="checkbox"/>		21. ABSTRACT SECURITY CLASSIFICATION UNCLASSIFIED	
22a. NAME OF RESPONSIBLE INDIVIDUAL David Judson		22b. TELEPHONE NUMBER (Include Area Code) (513) 255-7371	22c. OFFICE SYMBOL WRDC/MTI

13a. User Manual

18. Subject Terms (Continued)

Product Life Cycle

Engineering

Manufacturing

Interface

Exchange Format

CAD

CAM

CIM

## FOREWORD

This User's Manual (UM) describes work performed under Air Force Contract F33615-85-C-5122, Geometric Modeling Applications Interface Program (GMAP), covering the period 1 August 1985 to 31 July 1988. This UM provides a guide for the use of software developed under this contract which is sponsored by the Computer Integrated Manufacturing Branch, Materials Laboratory, Air Force Systems Command, Wright Air Force Base, Ohio 45433-6533. The GMAP Project Manager for the Air Force is Mr. Charles R. Gilman.

The primary contractor is Pratt & Whitney, an operating unit of United Technologies Corporation. Mr. Richard Lopatka is managing the GMAP project at Pratt & Whitney. Ms. Linda Phillips is the Program Integrator, and Mr. John Hamill is the Deputy Program Manager.

McDonnell Aircraft Company is the subcontractor responsible for the Retirement for Cause interface task. Mr. Jerry Weiss is the GMAP Program Manager at McDonnell Aircraft, and Mr. Herb Ryan is the Deputy Program Manager.

NOTE: The number and date in the upper right corner of each page in this document indicate that it has been prepared in accordance to the ICAM CM Life Cycle Documentation requirements for a Configuration Item (CI).

TABLE OF CONTENTS

		Page
SECTION 1.	SCOPE .....	1-1
1.1	Identification .....	1-1
1.2	Introduction .....	1-1
1.3	Other System Manuals .....	1-1
1.4	Approach .....	1-2
SECTION 2.	REFERENCES .....	2-1
2.1	Reference Documents .....	2-1
2.1.1	Military .....	2-1
2.1.2	Commercial .....	2-3
2.1.3	Standards Organizations .....	2-4
2.2	Terms and Acronyms .....	2-4
2.2.1	Terms Used in GMAP .....	2-4
2.2.2	Acronyms Used in GMAP .....	2-13
SECTION 3.	SYSTEM OPERATIONS .....	3-1
3.1	System Architecture .....	3-1
3.1.1	System Interfaces .....	3-1
3.1.2	System Environment .....	3-1
3.2	Schema Manager .....	3-3
3.2.1	Physical Schemas .....	3-3
3.3	Exchange Format (EF) .....	3-3
3.4	System Translator .....	3-3
SECTION 4.	POSTPROCESSING (EF TO WF) PROCEDURES .....	4-1
4.1	Introduction .....	4-1
4.2	Initialization Procedures .....	4-1
4.3	Postprocessor Invocation .....	4-2
4.3.1	Parameter Definitions .....	4-2
SECTION 5.	PREPROCESSING (WF TO EF) PROCEDURES .....	5-1
5.1	Introduction .....	5-1
5.2	Initialization Procedures .....	5-1
5.3	Preprocessor Invocation .....	5-2
5.3.1	Parameter Definitions .....	5-2
APPENDIX A	UNDERSTANDING THE MAPPING FROM THE DATA DICTIONARY INTO THE WF MODEL .....	A-1

LIST OF ILLUSTRATIONS

Figure	Title	Page
3-1	Product Information Exchange System Software .....	3-2
3-2	System Translator Architecture .....	3-4

**LIST OF TABLES**

<b>Table</b>	<b>Title</b>	<b>Page</b>
4-1	Postprocessor Parameter Definitions .....	4-2
5-1	Preprocessor Parameter Definitions .....	5-2

## SECTION 1

### SCOPE

#### 1.1 IDENTIFICATION

This User's Manual provides a guide for the use of the System Translator developed for the Geometric Modeling Applications Interface Program (GMAP), Project 5602, Air Force Contract F33615-85-C-5122.

The Product Definition Data Interface (PDDI) Program, Project 5601, Contract F33615-82-C-5036, provided the foundation for GMAP. The goal of the PDDI Program was to develop computerized communications to replace the traditional engineering drawings used between engineering and manufacturing environments. GMAP refines and extends this product definition data to include data needed to support applications throughout the entire product life cycle. The overall objectives of GMAP are to identify, establish, and demonstrate the use of computerized product definition data in the engineering, manufacturing, and logistics support of complex structural components.

#### 1.2 INTRODUCTION

Capabilities documented in this manual include:

- 'PUT' a GMAP model into the Working Form — postprocessor
- 'GET' a GMAP model from the Working Form — preprocessor.

This GMAP/PDDI software operates on IBM 43xx, 308xx or DEC VAX 11/780 computers. The environmental requirements are described in Section 3.

The GMAP/PDDI system documentation does not address the local (native) system or computing environment documentation.

This manual addresses IBM procedures and terminology only. All real and integer numbers residing in the Working Form are assumed to be signed and are translated into the Exchange Format as such. If the user is not using the provided GMAP/PDDI postprocessor, they must be aware of this and read the numbers as signed from the Exchange Format in the translator.

#### 1.3 OTHER SYSTEM MANUALS

The associated Operator's Manual (OM56024001U) describes the system operation and installation procedures. It is intended for use by computer operators and programming personnel.

An associated Model Access Software User's Manual (UM 560240001U) provides a guide for application programmers to use the Model Access Software. Capabilities described in this manual are Model Access Software initialization; entity creation, deletion and manipulation; and list operations. A Schema Manager User's Manual (UM560240011U) provides documentation for users of the Schema Manager.

The GMAP/PDDI System Component Product Specification provides routine descriptions, Data Dictionary listings, and PDDI system messages for system maintenance purposes.

#### 1.4 APPROACH

This User's Manual is divided into the six main sections listed below.

- Section 1** — Scope of this document.
- Section 2** — Reference documentation applicable to GMAP and this document.
- Section 3** — The GMAP/PDDI architecture at a high level, system environmental needs, system interfaces, printout procedures, and translator initialization and termination procedures.
- Section 4** — The postprocessor procedures. The postprocessor 'GETS' a model from the Exchange Format and 'PUTS' into the Working Form.
- Section 5** — The preprocessor procedures. The preprocessor 'GETS' a model from the Working Form and 'PUTS' it into the Exchange Format.
- Appendix A** — Understanding and mapping into the Working Form.

## SECTION 2

### REFERENCES

#### 2.1 REFERENCE DOCUMENTS

The following technical reports, specifications, standards, and other documents have been referred to or are relevant to this System Translator User's Manual.

##### 2.1.1 Military

Integrated Computer Aided Manufacturing (ICAM) Architecture, Vol. 4, Function Modeling Manual (IDEF0), USAF Report No. AFWAL-TR-81-4023, June 1981.

Integrated Computer Aided Manufacturing (ICAM) Architecture, Vol. 5, Information Modeling Manual (IDEF1), USAF Report No. AFWAL-TR-81-4023, June 1981.

Integrated Computer Aided Manufacturing (ICAM) Documentation Standards, IDS 150120000C, September 1983.

PDDI System Specification, Product Definition Data Interface (PDDI) Project 5601, Contract F33516-82-5036, July 1984.

PDDI System Specification-Draft Standard, Product Definition Data Interface (PDDI), Project 5601, Contract F33516-82-5036, July 1984.

Information Modeling Manual IDEF-Extended (IDEF1X) Integrated Information Support System (IISS), ICAM Project 6201, Contract F33615-80-C-5155, December 1985.

Interim Technical Report No.1 (ITR560240001U)  
'Geometric Modeling Applications Interface Program' February 1986  
(Period 1 August 1985 - 31 October 1985).

Interim Technical Report No. 2 (ITR560240002U)  
'Geometric Modeling Applications Interface Program' May 1986  
(Period 1 November 1985 - 31 January 1986).

Geometric Modeling Applications Interface Program (GMAP) Scoping Document, CI SD560240001U, May 1986.

Interim Technical Report No. 3 (ITR560240003U)  
'Geometric Modeling Applications Interface Program' August 1986  
(Period 1 February 1986 - 30 April 1986).

Interim Technical Report No. 4 (ITR560240004U)  
'Geometric Modeling Applications Interface Program' November 1986  
(Period 1 May 1986 - 31 July 1986).

Geometric Modeling Applications Interface Program (GMAP) Needs Analysis  
Document, CI NAD560240001U, November 1986.

Interim Technical Report No. 5 (ITR560240005U)  
'Geometric Modeling Applications Interface Program' January 1987  
(Period 1 August 1986 - 31 October 1986).

Geometric Modeling Applications Interface Program (GMAP) System  
Requirements Document, CI SRD560240001U, February 1987.

Geometric Modeling Applications Interface Program (GMAP) State of the Art  
Document, CI SAD560240001U, March 1987.

Interim Technical Report No. 6 (ITR560240006U)  
'Geometric Modeling Applications Interface Program' May 1987  
(Period 1 November 1986 - 31 January 1987).

Geometric Modeling Applications Interface Program (GMAP) System  
Specification (Volumes I-IV), CI SS560240001U, July 1987

Interim Technical Report No. 7 (ITR560240007U)  
'Geometric Modeling Applications Interface Program,' August 1987  
(Period 1 February 1987 - 30 April 1987).

Geometric Modeling Applications Interface Program (GMAP) System Design  
Specification, CI SDS560240001U, November 1987.

Geometric Modeling Applications Interface Program (GMAP) Retirement for  
Cause Development Specification, CI DS560240011U, November 1987.

Geometric Modeling Applications Interface Program (GMAP) Integrated Blade  
Inspection System Development Specification, CI DS560240021U, November  
1987.

Geometric Modeling Applications Interface Program (GMAP) Retirement for  
Cause Product Specification, CI PS560240011U, December 1987.

Geometric Modeling Applications Interface Program (GMAP) Retirement for  
Cause Unit Test Plan, CI UTP560240011U, December 1987.

Interim Technical Report No. 8 (ITR560240008U)  
'Geometric Modeling Applications Interface Program,' December 1987  
(Period 1 May 1987 - 31 July 1987).

Interim Technical Report No. 9 (ITR560240009U)  
'Geometric Modeling Applications Interface Program,' March 1988  
(Period 1 August 1987 - 31 October 1987).

Product Definition Data Interface (PDDI)/Geometric Modeling Applications  
Interface Program (GMAP) Deliverables Roadmap Document, March 1988.

Interim Technical Report No. 10 (ITR560240010U)  
'Geometric Modeling Applications Interface Program,' August 1988  
(Period 1 November 1987 - 31 January 1988).

Interim Technical Report No. 11 (ITR560240010U)  
'Geometric Modeling Applications Interface Program,' August 1988  
(Period 1 February 1988 - 30 April 1988).

Geometric Modeling Applications Interface Program (GMAP) Retirement for  
Cause Interface User Operator Manual, CI U/OM560240011U, August 1988.

Interim Technical Report No. 12 (ITR560240012U)  
'Geometric Modeling Applications Interface Program' October 1988  
(Period 1 May 1988 - 31 July 1988).

Geometric Modeling Applications Interface Program (GMAP) Retirement for  
Cause Interface Unit Test Report, CI UTR560240011U, October 1988.

Geometric Modeling Applications Interface Program (GMAP) Integrated Blade  
Inspection System Interface Unit Test Report, CI UTR5602421U, October 1988

Geometric Modeling Applications Interface Program (GMAP) System  
Translator User Manual, CI UM560240021U, October 1988

### 2.1.2 Commercial

A Practical Guide to Splines, C. de Boor, Applied Mathematical Sciences, Vol.  
27, Springer-Verlag.

Design of Database Structures, T. J. Teorey and J. P. Fry, Prentice-Hall, Inc.,  
Englewood Cliffs, N.J.

Differential Geometry of Curves and Surfaces, M. P. de Carmo, Prentice-Hall,  
Inc., 1976.

IDEF1X Readers Reference, D. Appleton Company, December 1985.

Identification of Product Definition Data in a Manufacturing Enterprise — A  
Case Study, R. Lessard, United Technologies Research Center and R. Disa,  
Pratt & Whitney, March 1986.

Use of Product Models in a CIM Environment, D. Koziol Emmerson and K. Perlotto, Pratt & Whitney, March 1987.

Technical Issues in Product Data Transfer, Richard Lopatka, Pratt & Whitney, September 1987.

Implementation of GMAP Technologies for Logistic Support Applications, Donald L. Deptowicz, Pratt & Whitney, January 1988.

Barriers to PDES Approval, Anthony Day, Sikorsky, and Richard Lopatka, Pratt & Whitney, April 1988.

### 2.1.3 Standards Organizations

ANSI Y14.5M, Dimensioning and Tolerancing.

'The ANSI/X3/SPARC DBMS Framework Report of the Study Group on Database Management Systems,' Information Systems, Vol. 3, pp. 173-191, 1978.

The Second Draft Report of the Ad Hoc Committee on the Content and Methodology of the IGES Version 3 (The Second PDES Report), K. Brauner and D. Briggs, November 1984.

EXPRESS - A Language for Information Modeling, ISO, TC184/SC4/WG1, January 1986.

The STEP File Structure, ISO, TC184/SC4/WG1, January 1987.

Mapping from EXPRESS to Physical File Structure, ISO, TC184/SC4/WG1, January 1987.

## 2.2 TERMS AND ACRONYMS

A glossary of terms frequently used in GMAP which may be included in this System Translator User's Manual is provided below. A list of acronyms and abbreviations used in GMAP is also included in this section.

### 2.2.1 Terms Used in GMAP

**Accept/Reject/Incomplete Notice** — A display on the cell computer that indicates the final status of the engine disk.

Accept	= Acceptable within tolerance specified by engine manufacturer
Reject	= Rejected because of flaw(s) outside the range of acceptable tolerances
Incomplete	= Part cannot be inspected

**Access Software** — A set of routines for creating, managing, and querying an incore Working Form model.

**Angular** — An angular size tolerance is used to tolerance the size of an angular feature independent of its angular location along an arc.

**Application** — A method of producing a specific result.

**Application Request** — A request initiated by an application program, either through batch or interactive processing, which will interrogate the model through the PDDI Access Software to obtain or operate on specific information regarding the model and its components or elements.

**Application Requested Data** — The data which fulfill the application's original request and which is in the proper format and readable by the application.

**Architecture** — A design or orderly arrangement.

**ASCII** — American Standard Code for Information Interchange.

**As-Is** — The present condition.

**Attribute** — A quality of characteristics element of any entity having a name and a value.

**B-Spline** — A spline defined by a control polygon, B-spline basis functions, and an associated knot vector. A Bezier curve is a special case of a B-spline; a nurb is the most general case of a B-spline.

**Bezier Curve** — A type of curve defined by a set of vertices called a control polygon and a set of basis functions. The basis functions are known as Bernstein polynomials. K vertices define a curve of order K-1.

**Binding** — Establishing specific physical references to data structures for an application program; may be performed at compile time or at run time.

**Blend** — A smooth, continuous transition from one surface to another.

**Boundary Representation** — A topology imposed on 3-D geometric entities to yield a general solid model. That model describes an object by describing its boundary area.

**Body of Revolution (BOR) Representation** — A topology in which an object is represented as the volume swept by a curve rotated about a line. This is a boundary representation in which the curve represents the surface area of the object.

**Bounded Geometry** — Geometry that has limits defined by its mathematical domain or range.

**Calibration Block Parameters (Scale Factors)** — Nondestructive test parameters used to adjust a specific cell. These parameters are obtained from the calibration blocks located at each cell.

**Circumferential** — A circumferential tolerance specifies the tolerance zone within which the average diameter of a circular feature must lie. The average diameter is the actual circumference

divided by pi (3.14159). A circumferential tolerance is a specific example of a peripheral or perimeter tolerance for a general curve.

**Class** — A collection of entities that are alike in some manner.

**CLIST** — IBM Command lists.

**Composite Curve** — A group of curve segments that are  $C^0$  continuous.

**Compound Feature Representation** — An enumerative feature representation in which at least one component is itself a feature. For example, a bolt hole circle might be represented as a list of individual hole features.

**Concentricity (Generic)** — A concentricity tolerance specifies a cylindrical tolerance zone within which the axis of a feature must lie, where the axis of the zone coincides with the axis of the datum.

**Conceptual Schema** — Formally specified global view that is processing independent, covering information requirements and formulation of independent information structures. A neutral view of data, usually represented in terms of entities and relations.

**Conic** — A quadratic curve represented in the most general case by the equation:

$$Ax^2 + Bxy + Cy^2 + Dx + Ey + F = 0.$$

A conic may be a circle, line, ellipse, parabola, or a hyperbola depending on the coefficients, A, B, C, D, E, and F.

**Constraints (Generic)** — An assertion to explicitly specify data meaning or semantics.<sup>1</sup>

**Context-Free Grammar** — The syntax of the language gives a precise specification of the data without interpretation of them.

**Constituent** — A specific instance of an entity that is used in the definition of some other entity.

**Data Dictionary** — A catalog of all data elements in a design, giving their name, definition, format, source, and usage. May also include data types and value limits.

**Defining Airfoil Sections** — A planar or conical section that depicts an airfoil profile. Defining airfoil sections are those that meet aerodynamic requirements. Other intermediate sections are added for Manufacturing purposes.

**Dimension** — A part dimension is a quantifiable value expressing size, form, or location.

**Domain** — The set of values permissible in a given context.

<sup>1</sup> T.J. Teorey and J.P. Fry, Design of Database Structures, 1st edition, Prentice-Hall, Inc., Englewood Cliffs, N.J., p. 463.

**Dynamic Allocation** — The allocation (and deallocation) of memory resources as required by the application. The opposite is **static** allocation where a fixed size segment of memory is available to the application.

**Eddy Current Cell** — Hardware used to perform an Eddy current inspection operation (surface flaws).

**Eddy Current Inspection** — An inspection method used to detect internal potential flaws on a disk. It is based on the principle of sending electromagnetic signals to a target area on a part and detecting/interpreting reflection (Eddy current) from the target.

**Eddy Current Scan Plan** — An interpreter code program controlling the Eddy current inspection of a particular geometry.

**Eddy Current/Ultrasonic Flaw Data Printout** — A printout containing size and location information about specific flaw(s) (both critical and noncritical) associated with a particular part.

**Entity** — A description of a person, place, or thing, about which information is kept.

**External Reference** — A reference to some quantity of data that exists somewhere outside the scope of the immediate body of information.

**Feature** — A part feature in the dimensioning and tolerancing context is a feature in the sense of ANSI Y14.5M, that is, a physical component portion of a part, such as a surface, hole, slot, and so on, that is used in a tolerancing situation. In the dimensioning and tolerancing context, a feature consists of individual or groups of basic shape elements used to define the physical shape of an item. This general dimensioning and tolerancing use of features is to be distinguished from Features. The word "features" alone implies dimensioning and tolerancing features. The term "form feature" is described below.

**Feature Pattern** — A geometric pattern of occurrences of similar form features, for example, a circular pattern of scallops, a rectangular array of holes.

**Feature Representation (Generic)** — A description of a form feature within the context of a geometric model.

**Feature Type** — A name applied to a form feature that is suggestive of its shape and size, for example, hole, slot, web.

**Feature of Size (Generic)** — A feature of size provides a geometric location capable of being referenced for use with datums and tolerances. A feature of size can be a GMAP feature, or other referenceable shape elements of a part model that are symmetric about a point, line, plane, axis, curve, and so on. When a feature of size is used in a relationship with a tolerance or datum, its feature of symmetry is the implied reference.

**Flat Pattern Representation (Extrusion Representation)** — A topology in which an object is represented as the volume swept by a planar polygon moving in a direction normal to its plane. The polygon may have internal polygon represent the surface area of the object.

**Flaw Characteristics** — Location, length, width, depth, and nondestructive test parameters associated with a specific flaw.

**Flaw Data Packet** — Packet containing nonevaluated flaw data. Note that the packet can contain zero flaws.

**Flaw Orientation** — The direction of the major characteristic of the flaw with respect of the part coordinate system.

**Flaw Suspect Location** — The coordinate location of a possible flaw detected during a survey mode inspection (six-axis position of ultrasonic cell, seven-axis position of Eddy current cell).

**Form Feature** — A portion of a part's geometry that is useful to regard as an entity. In a boundary representation context, this is a subset of the part's surface area.

**Form Tolerance** — Form tolerances are used to control the form of model features. A form tolerance specifies the amount that an actual features form may vary from nominal. Form tolerance include straightness tolerance, flatness tolerance, roundness/circularity tolerance, cylindricity tolerance, perpendicularity tolerance, parallelism tolerance, angularity tolerance, profile-of-a-line tolerance, profile-of-a-surface tolerance, circular-runout tolerance, true-direction tolerance, and mismatch tolerance.

**Functionality** — (1) To show that the configuration item has fulfilled the specified requirements. (2) The receiving and sending systems can operate on the entity in the same manner with the same results within a pre-defined tolerance.

**Function Modeling** — A description of a system in terms of a hierarchy of functions or activities, each level decomposing higher ones into greater detail. Functions are named by verbs; nouns related are declared as inputs, controls, outputs, and mechanisms.

**Geometric Element (Generic)** — An instance of a geometric entity.

**Geometric Group** — A group of geometric entities with a name.

**Geometric Model** — A part description in terms of its underlying geometric elements. The model may be a wireframe, surface, or solid model.

**Geometric Pattern** — A circular or rectangular pattern of geometric entities.

**Group Technology Code** — An alphanumeric string identifying significant characteristics of a product, enabling group technology applications. Also known as Part Classification Code.

**Include File** — PASCAL source code from another file or library included on the compilation of a PASCAL source file.

**Input Data** — That information which the application needs to supply in order to interrogate or operate on the model. These data may assume only these forms prescribed by the PDDI Access Software specification.

**Inspection Cycle** — A period for which nondestructive testing inspection requirements are defined.

**Inspection Cycle Zone** — An entity that is composed of a unique combination of zone and inspection cycle.

**Inspection Module Operator** — Refers to personnel operating RFC cell(s).

**Instrument Setting Adjustments** — Nondestructive testing parameter adjustments automatically accomplished via pre- and post-calibration operations. These adjustments have to be accomplished within a predetermined tolerance.

**Internal Flaw** — A subsurface anomaly.

**Internal Flaw Major Characteristic** — A vector determined by an agreed upon method.

Example (1): The vector of greatest magnitude from the centroid to a boundary of the anomaly.

Example (2): A vector representing the major axis of the minimum ellipsoidal envelope encompassing the anomaly.

**Internal Flaw Tolerance** — A unique combination of:

- (a) Internal flaw orientation range.
- (b) Serviceable internal flaw tolerance limits.
- (c) Repairable internal flaw tolerance limits.

**Internal Flaw Tolerance Limit** — A unique combination of:

- (a) Maximum diameter.
- (b) Maximum depth below surface.
- (c) Maximum thickness.

**Interpreted Request** — Input data which have been appropriately modified to conform to the PDDI Access Software's internal data representation so that they may be further processed.

**Key Attribute** — An attribute or combination of attributes having values that uniquely identify each entity instance.<sup>2</sup>

**Laminates Representation (Generic)** — A topology in which an object is represented as layers of flat material of known thickness.

**Location Tolerance** — Location tolerances specify the allowable variation in position of model features. Location tolerances include various forms of position tolerancing conventions. These are (true) position, concentricity, alignment, rectilinear location, and angular location.

<sup>2</sup> Integrated Computer Aided Manufacturing (ICAM) Architecture, Vol. 5, Information Modeling Manual (IDEF1), USAF Report NO. AFWAL-TR-81-4023, June 1981, p. 212.

**Logistics Support** — The function of procuring, distributing, maintaining, replacing, and repairing material in support of a delivered product.

**Machine Coordinate Positions** — The probe location with respect to machine coordinates.

**Machine Preset Data** — Machine coordinate adjustments automatically accomplished via pre- and post-calibration operations. These adjustments have to be accomplished within predetermined tolerance.

**Metadata** — Data about data. Defines the physical schema and record formats of the part data.

**Metamodel** — A body of data that defines the characteristics of a data model or structure.

**Model** — A collection of PDD that is transferable, displayable, accessible, and equivalent to a Part. The internal representation of the application data, as initiated and organized by the user. The model is also referred to as the Working Form.

**Model Network Definition** — The set of rules and definitions which outline in detail the data structure whereby higher order entities may be composed of lower order entities, or constituents, and the lower order entities may be constituents of one or more higher order entities.

**Native System** — The PDD and applications in a format that is unique to the database of a CAD system.

**Nondestructive Testing Parameters** — Parameters used by the Eddy current and ultrasonic instruments (examples: amplitude, phase angle, gain, threshold, and so on).

**Nonconstructive Feature Representation (Explicit Feature Representation)** — A feature representation that at least partially depends on a declaration that a face, or portion of a face, is "in" the feature.

**Nondestructive Testing Personnel** — Personnel responsible for the generation of scan plans and derivation of applicable nondestructive testing instrument settings used in the scan plans.

**Nonshape Data** — Produce definition data that cannot be represented by shape elements.

**Normal Forms** — Conditions reflecting the degree of refinement and control over the relationships and entities in an information model.

**Numerical Control Program (Complete and Proposed)** — Set of program instructions used to generate a probe path.

**Orientation Range** — An envelope in which the major flaw characteristic must lie.

**Parse** — The process of analyzing input strings (records) to identify fields and to verify that the data have a valid format.

**Part Blueprint** — A blueprint provided by the engine manufacturer of a particular F100 engine disk.

**Physical Schema** — Internal representation of data; the computer view that includes stored record format and physical ordering of stored records.

**Polynomial Spline** — A parametric spline of order 1, 2, or 3 defined by a set of N+1 points. The spline is CX, CY, or CZ continuous and defined by coefficients such that:

$$x(i) = AX_{(i)} + BX_{(i)} * S + CX_{(i)} * S^{**2} + DX_{(i)} * S^{**2}$$

$$y(i) = AY_{(i)} + BY_{(i)} * S + CY_{(i)} * S^{**2} + DY_{(i)} * S^{**2}$$

$$z(i) = AZ_{(i)} + BZ_{(i)} * S + CZ_{(i)} * S^{**2} + DZ_{(i)} * S^{**2}$$

and a parameter space  $(T_0, T_1, \dots, T_n)$

where

$$T_{(i)} < = u < = T_{(i+1)}$$

$$S = u - T_{(i)}$$

**Position Tolerance** — A position tolerance (true position) specifies a tolerance zone within which the feature may vary in any direction.

**Post-processor** — A phase of the translator where data are received from the Exchange Format and are converted to the Working Form.

**Pre-processor** — A phase of the translator where data are taken from the Working Form and are converted to the Exchange Format.

**Primitive Constructive Feature Representation (Generic)** — A constructive representation that is noncompound and that does not incorporate another feature. Such a representation must consist solely of overt construction information. Representation of a through hole by centerline and diameter is an example.

**Probe Blueprint** — Blueprint of Eddy current probe supplied by the probe manufacturer.

**Product Definition Data** — Those data “explicitly representing all required concepts, attributes, and relationships” normally communicated from Design throughout Manufacturing and Logistics Support. The data include both shape and nonshape information required to fully represent a component or assembly so that it can be analyzed, manufactured, inspected, and supported. They enable downstream applications, but do not include process instructions. These data are not always finalized at the design release; the manufacturing process can also add to the product model or generate derived manufacturing product models.

**Product Life Cycle** — Includes design, analysis, manufacturing, inspection, and product and logistics support of a product.

**Product Model** — A computer representation of a product.

**Product Support** — The function that interprets customer requests for information and can provide the technical responses to the customer in the form of technical orders and instructions.

**Proprietary Part Flaw Data** — Formatted dataset containing proprietary data defining size(s), maximums, and location(s) of critical flaw(s) (dimensional and locational tolerance).

**RAW.0 File** — A data file that uses a bi-cubic patch surface representation to define the surfaces of an airfoil.

**Ready Status** — Go/No-Go decision.

**Relation** — A logical association between entities.<sup>3</sup>

**Remount Decision** — Decision to remount an engine disk.

**Replicate Feature Representation (Generic)** — A description of a feature as being identical to another feature except for location. Mathematically, a replicate feature representation consists of the identification of another (necessarily constructive) feature plus a transformation.

**Robot Initialization Parameters** — A set of nondestructive testing parameters used to initialize the robot on an Eddy current or ultrasonic cell.

**Rotational Sweep** — A sweep in which the swept curve is rotated about a line (the "centerline" of the sweep).

**Ruled Surface (Generic)** — A surface defined by a linear blend of two curves.

**Run System** — The Translator subpackage which provides the communication interface between the user and the pre/post-processors.

**Run-Time Subschema** — A subset of the data dictionary information used at run-time by the access software to provide field data and check data.

**Scan Plan** — Instructions that drive an inspection; these include inspection area geometry, ordered inspection path points, inspection probe selection, inspection path for each probe, mechanical commands that allow mechanical manipulator positioning, instrument setting, and all the variables needed for signal processing and flaw data acquisition during inspection.

**Scan Plan Specifications** — Standards and procedures used in creating Eddy current and ultrasonic scan plans for the RFC system.

<sup>3</sup> Ibid., p. 214.

**Schema** — Formal definition of information structure. See Conceptual Schema, Physical Schema, Run-time Schema.

**Shape** — The physical geometry of a mechanical part, as distinguished from a computer description of that geometry. Where the difference is significant, the attitude is taken that shape is nominal or basic, with shape variations of tolerances grafted thereon.

**Shape Data** — Include the geometric, topological description of a product along with the associated dimensional tolerances and feature descriptions.

**Single Spatial Probe/Transducer Path** — The starting and ending location of a single probe movement.

**Size Tolerance** — Size tolerances specify the allowable variation in size-of-model features, independent of location. Size tolerances include circumferential, rectilinear size, and angular size.

**Solid Geometric Model (Shape Representation)** — A computer description of shape. The description may be partial in the sense that not all aspects of part shape are indicated. For example, a body of revolution representation of a turned part may not describe the nonaxisymmetric<sup>4</sup> aspects of part geometry. A solid model must be complete and unambiguous in the sense that it describes a single volume in 3-D space.

**Solid Modeling** — The creation of an unambiguous and complete representation of the size and shape of an object.

**Source Code** — A computer program written in some language which is processed to produce machine code.

**Spline** — A piecewise polynomial of order K, having continuity up to order K-1 at the segment joints.

**Squirter Blueprint** — Blueprint of the squirter head that houses the ultrasonic transducer.

**Subface** — A subface is a bounded portion of a face. It is defined by an underlying face, exactly one periphery closed curve and zero, one, or more internal closed curves that represent cutouts or holes in the region. The internal closed curve must not touch or intersect each other or the periphery closed curve and must be entirely contained within the periphery closed curve.

**Surface Flaw** — A surface anomaly.

**Surface Flaw Major Characteristic** — A vector determined by an agreed upon method.

**Example:** A vector representing the major axis of the minimum elliptical envelope encompassing the anomaly in the plane of the surface.

<sup>4</sup> Ibid., p. 211.

**Surface Flaw Tolerance** — A unique combination of:

- (a) Surface flaw orientation range.
- (b) Serviceable surface flaw tolerance limits.
- (c) Repairable surface flaw tolerance limits.

**Surface Flaw Tolerance Limit** — A unique combination of:

- (a) Maximum length.
- (b) Maximum width.
- (c) Maximum depth.

**Sweep Surface** — Surfaces formed by extruding or revolving a planar profile in space.

**Syntax** — Grammar: A set of rules for forming meaningful phrases and sentences from words in a vocabulary.

**System Computer** — VAX 11/780 and supporting peripheral hardware.

**System Constraints** — Those hardware and software environmental constraints which will be imposed upon the PDDI Access Software that will limit its implementation and application. An example of such constraints might be the particular compiler used to compile the PDDI Access Software package.

**To-Be** — The future condition possible, given a proposed capability.

**Tolerance (Generic)** — The total amount by which something may vary. For mechanical product definition, tolerances can be shape tolerances, weight tolerances, finish tolerances and so on. In the context of GMAP, the term "tolerance" used alone implies shape tolerance. Other forms of tolerance (nonshape) are explicitly stated, for example, "finish tolerance." In a GMAP product model, tolerances occur without dimensions. As in the Product Definition Data Interface Program, model dimensions are implicit in the model geometry. Therefore, application of a tolerance implies a specific underlying dimension or geometric condition.

**Topology** — A data structure that assembles geometric entities (points, curves, surfaces) into a solid geometric model.

**Transducer Blueprint** — Blueprint of ultrasonic transducer supplied by the transducer manufacturer.

**Transfer Data** — The data required to make an exchange of data between systems (i.e., delimiters, record counts, record length, entity counts, numeric precision).

**Translator** — A software MECHANISM that is used for passing data between the Exchange Format and Working Form of the PDD.

**Ultrasonic Cell** — Hardware used to perform ultrasonic inspection operation (internal flaws).

**Ultrasonic Inspection** — An inspection method used to detect surface flaws on a disk. It uses ultrasonic waves through a stream of water to send and collect signals concerning an area targeted for inspection.

**Ultrasonic Scan Plan** — Interpreter code program controlling the ultrasonic inspection of a particular geometry.

**Unbounded Geometry** — Geometry represented parametrically, without limits, usually by coefficients to a defining equation.

**Unigraphics (UG)** — A computer graphics system.

**User Function (UFUNC)** — An interface to the UG database.

**Working Form** — Product definition data information in machine-dependent data formats; a memory resident network model.

**Zone** — A physical area of the disk composed of zone components.

**Zone Component** — A subface, face, or feature that constitutes a zone or element of a zone.

## 2.2.2 Acronyms Used In GMAP

ADB	— Application Data Block (also referred to as Attribute Data Block).
AIMS	— Automated IDEF Methodology System.
ANSI	— American National Standards Institute.
ANT	— Abstract of New Technology.
APT	— Automatically Programmed Tools.
ATP	— Automation Technology Products
BOM	— Bill of Materials.
BOR	— Body of Revolution.
BPI	— Bits per Inch.
BREP	— Boundary Representation.
CAD	— Computer Aided Design.
CAE	— Computer Aided Engineering.
CAEDS	— Computer Aided Engineering Design System.
CALS	— Computer-aided Acquisition and Logistics.
CAM	— Computer Aided Manufacturing.
CAM-I	— Computer Aided Manufacturing--International.
CAPP	— Computer Aided Process Planning.
CAS	— Cooled Airfoil System.
CDM	— Common Data Model.
CDR	— Critical Design Review.
CDT	— Component Design Technology.
CFSR	— Contract Fund Status Report.
CI	— Configuration Item.
CIM	— Computer Integrated Manufacturing.

CLIST	— IBM Command List.
CM	— Configuration Management.
CMM	— Coordinate Measuring Machine.
C/SSR	— Cost/Schedule Status Report.
CWBS	— Contract Work Breakdown Structure.
DBMS	— Data Base Management System.
DCL	— DEC Command Language.
DDL	— Data Definition Language.
DEA	— Digital Equipment Automation.
DEC	— Digital Equipment Corporation.
DES0	— (ICAM) Architecture of Design.
DJR	— Design Job Request; Drafting Job Request.
DoD	— Department of Defense.
DS	— Design Specification.
DSM	— Design Substantiation Memo.
EBCDIC	— Extended Binary Coded Decimal Interchange Code (IBM Character Set).
EC	— Eddy Current.
ECO	— Engineering Change Order.
EDM	— Electrical Discharge Machining.
EF	— Exchange Format.
EII	— Engineering Information Index.
EMD	— Engineering Master Drawing.
EPCS	— Engine Product Configuration Support.
ESA	— Engineering Source Approval.
ESP	— Experimental Solids Proposal.
FEDD	— For Early Domestic Dissemination.
FEM	— Finite-Element Modeling.
FOF	— Factory of the Future.
FOS	— Feature of Size.
FPIM	— Fluorescent Penetrant Inspection Module.
FSCM	— Federal Supply Code for Manufacturers.
GE	— General Electric.
GMAP	— Geometric Modeling Applications Interface Program.
GSE	— Ground Support Equipment.
HCF	— High-Cycle Fatigue.
IBIS	— Integrated Blade Inspection System.
IBM	— International Business Machines.
ICAM	— Integrated Computer Aided Manufacturing.
ICOM	— Input/Control/Output/Mechanism.
ICS	— Information Computer System.
IDEF	— ICAM Definition.
IDEF0	— IDEF Function Modeling.
IDEF1	— IDEF Information Modeling.
IDEF1X	— IDEF Extended Information Modeling.
IDEF2	— IDEF Dynamics Modeling.
IDSS	— Integrated Decision Support System.

IEEE	—Institute of Electrical and Electronics Engineers.
IEN	—Internal Engineering Notice.
IFS	—Interface Specification.
IGES	—Initial Graphics Exchange Specification.
IISS	—Integrated Information Support System.
ILC	—Improved Life Core.
IMS	—Information Management System.
IPGS	—(IBIS) Inspection Plan Generation Subsystem.
IRB	—Industry Review Board.
IRIM	—Infrared Inspection Module.
ISO	—International Standards Organization.
ITA	—Intelligent Task Automation.
ITI	—International TechneGroup Incorporated.
ITR	—Interim Technical Report.
LCF	—Low-Cycle Fatigue.
MAS	—Model Access Software.
MCAIR	—McDonnell Douglas Corporation/McDonnell Aircraft Company.
MFG0	—(ICAM) Architecture of Manufacturing.
MRP	—Materials Requirements Planning.
NAD	—Needs Analysis Document.
NBS	—National Bureau of Standards.
N/C	—Numerical Control.
NDE	—Nondestructive Evaluation.
NDML	—Neutral Data Manipulation Language.
NDT	—Nondestructive Test.
NTSB	—National Transportation Safety Board.
NVI	—Name/Value Interface.
OGP	—Optical Gaging Products, Inc.
PA/QA	—Product Assurance/Quality Assurance.
PD	—Product Data.
PDD	—Product Definition Data.
PDDI	—Product Definition Data Interface Program.
PDES	—Product Data Exchange Specification.
PDL	—Program Design Language.
PED	—Preliminary Engine Design.
PI	—Principal Investigator.
PID	—PDDI Interim Database.
PIES	—Product Information Exchange System.
PMP/PMS	—Program Management Plan/Project Master Schedule.
PROCAP	—Process Capability.
PS	—Product Specification.
RFC	—Retirement for Cause Disk Inspection System.
RPM	—Revolutions per Minute.
SA-ALC	—San Antonio-Air Logistics Center.
SAD	—State-of-the-Art Document.
SD	—Scoping Document.
SDL	—Source Data List.

SDS	— System Design Specification.
SL	— Salvage Layout.
SML	— Source Material Log.
SOA	— State-of-the-Art (Survey).
SOR	— Surface of Revolution.
SPC	— Statistical Process Control.
SPF	— System Panel Facility.
SQA	— Software Quality Assurance.
SQAP	— Software Quality Assurance Plan.
SRD	— System Requirements Document.
SRL	— Systems Research Laboratories.
SS	— System Specification.
STEP	— Standard for the Exchange of Product Model Data.
STP	— System Test Plan.
TCTO	— Time Compliance Technical Order.
TD	— Technical Data.
TDCR	— Turbine Design Cost Reduction.
TDR	— Tool Design Request.
TechMod	— Technology Modernization.
TO	— Technical Order.
TOP	— Technical and Office Protocol.
TSO	— Time-Sharing Option (IBM term).
UFUNC	— User Function.
UG	— Unigraphics.
USA	— Unified System for Airfoils.
USAF	— United States Air Force.
UTC	— United Technologies Corporation.
UTP	— Unit Test Plan.
UTR	— Unit Test Report.
UTRC	— United Technologies Research Center.
VAX	— Virtual Architecture Extended.
VMS	— Virtual Memory System.
WBS	— Work Breakdown Structure.
WF	— Working Form.
WPAFB	— Wright-Patterson Air Force Base.
XIM	— X-Ray Inspection Module.

## SECTION 3

### SYSTEM OPERATIONS

#### 3.1 SYSTEM ARCHITECTURE

The purpose of the GMAP/PDDI software system is to provide a prototype for the communication of complete Production Definition Data (PDD) between dissimilar CAD/CAM systems. This system will serve as the information interface between engineering and manufacturing functions. Figure 3-1 presents the Product Information Exchange System Software.

The Conceptual Schema is a Data Dictionary that defines the data needed to define a CAD/CAM model. The Schema Manager is a software tool that will be used to manage all aspects of the creation and interrogation of the Conceptual Schema, and will be used to generate a physical schema. The Exchange Format (EF) is a neutral physical sequential format for passing data between dissimilar systems. The System Translator is the software mechanism for passing these data between the EF and the Working Form (WF) of the PDD. The Model Access Software (MAS) is a set of callable utility programs that will allow applications to manipulate and query PDD WF models. The Name Value Interface (NVI) frees applications programmers from the need to be concerned with the physical location of attribute values for entities within the WF.

##### 3.1.1 System Interfaces

The GMAP/PDDI software must interface with the computer system on which it is installed, the local (native) CAD/CAM database, the EF, the WF, and the user (application). It does this via the MAS, the System Translator, and local (native) developed software packages.

##### 3.1.2 System Environment

The GMAP/PDDI system was developed in the following computing environment:

###### Computer/Operating System

IBM 43XX/MVS with Time Sharing Option (TSO) and associated tape drives, disk drives, and terminals.

Digital Equipment Corporation (DEC) Virtual Architecture Extended (VAX) 11/780 Virtual Memory System (VMS) with associated tape drives, disk drives, and terminals.

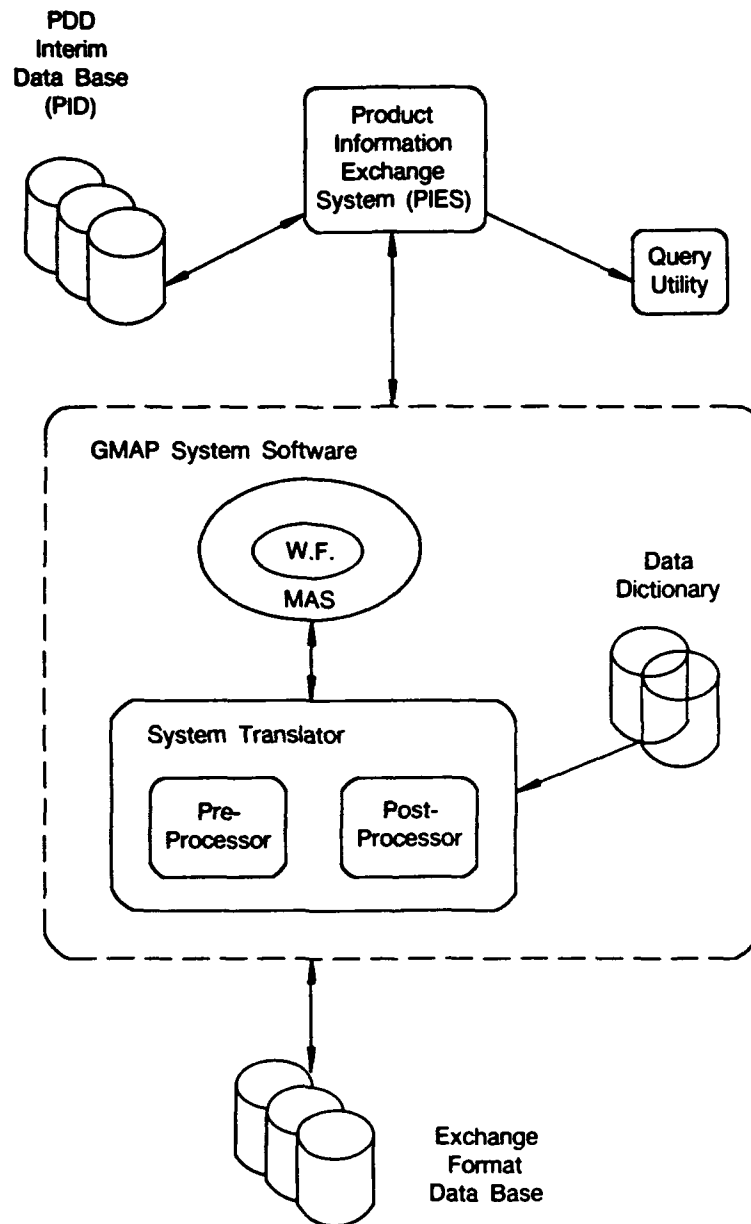

FDA 357864

Figure 3-1. Product Information Exchange System Software

The GMAP/PDDI software system is transportable to other computing systems. However, appropriate local (native) interfaces (translator) must be provided. The GMAP System Components Operator's Manual (OM 56024001U) provides information on migration to other systems.

### **Storage (Core) Requirements**

The minimum core requirements for the PDDI software and database are 1 megabyte (1.0M) plus the size of the model. (The PDDI Machined Rib model required 0.57M.)

### **Compilers**

IBM-PASCAL/VS Release 2.2  
DEC-PASCAL V3.3, FORTRAN 77 V4.4

### **Terminals**

E&S PS300 (or equivalent for graphics applications)  
IBM 3270 (or equivalent)

## **3.2 SCHEMA MANAGER**

The Schema Manager enables the data administrator to create and maintain entity definitions in a Conceptual Schema model, analyze the defined entities, and generate physical schema from the Conceptual Schema.

### **3.2.1 Physical Schemas**

The WF physical schema is determined through a Data Dictionary or PASCAL include files. The EF physical schema is defined by the Conceptual Schema and the specification for the neutral file format.

## **3.3 EXCHANGE FORMAT (EF)**

The EF is a neutral data format. This physical, sequential format is used for passing data between dissimilar CAD/CAM systems.

## **3.4 SYSTEM TRANSLATOR**

The System Translator is the software package used to format PDD for transmission between different CAD/CAM systems. The translator has a "preprocessor," which collects data from the sending system and formulates it into an EF file, and a "postprocessor," which collects the EF file and formulates it into the receiving system internal WF, as illustrated in Figure 3-2. The EF is based on the Product Data Exchange Specification (PDES) file format presented in the Standard for the Exchange of Product Model Data (STEP) document 4.2.1 Version 11.0, dated June 1988.

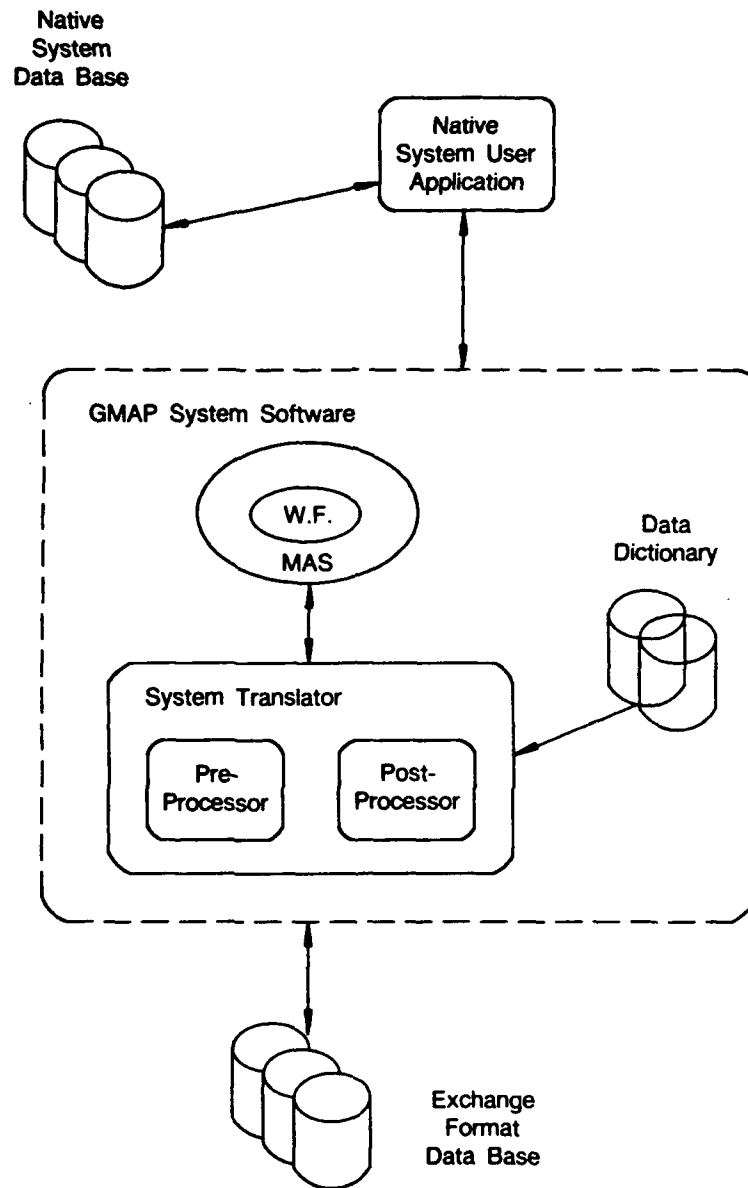

FDA 357865

Figure 3-2. System Translator Architecture

The **preprocessor** provides the interface from the WF to the EF.

WF entities, in the WF physical schema, are accessed via the MAS. External tables, or Data Dictionaries, are read in and are then used to map the WF entities to the EF physical schema. The EF entities are then encoded and placed into the EF file.

Error messages or condition codes are sent to the user's terminal to indicate the status of the transfer.

The **postprocessor** provides the interface from the EF to the WF.

External Data Dictionaries are read in and are then used to map the EF entities to the WF physical schema. The MAS is then used to place these entities into the WF.

Error messages or condition codes are sent to the user's terminal to indicate the status of the transfer.

## SECTION 4

### POSTPROCESSING (EF TO WF) PROCEDURES

#### 4.1 INTRODUCTION

The System Translator's postprocessor translates a model from the EF to the WF on the computer. This manual does not provide native system logon or terminal operating procedures because each local computing environment is unique.

It is assumed that the GMAP/PDDI software has been installed and compiled in the local computing system. (Refer to the GMAP Operator's Manual for installation details.) The remainder of this section will focus on the initialization procedures required to run the GMAP postprocessor from a native system application.

#### 4.2 INITIALIZATION PROCEDURES

For an IBM MVS/TSO application program successfully to call the System Translator's postprocessor, the steps listed below must be taken.

- STEP 1. — The Data Dictionary data file must be allocated to the logical filename (DDNAME) of "DDFILE." This allocation may be done in a TSO Command List (CLIST) or in Job Control Language (JCL).
- STEP 2. — The Data Dictionary index file must be allocated to the logical filename (DDNAME) of "DDINX." This allocation may be done in a TSO Command List (CLIST) or in Job Control Language (JCL).
- STEP 3. — The EF file must be allocated to the logical filename (DDNAME) of "EFFILE." This allocation may be done in a TSO Command List (CLIST) or in Job Control Language (JCL).
- STEP 4. — Error messages are written to the logical file name (DDNAME) of "OUTPUT." The user may allocate this file to a dataset or to his terminal screen.
- STEP 5. — The GMAP System Translator is written in PASCAL and, as a result, it requires a PASCAL run-time environment to be established. (Refer to the GMAP MAS User's Manual — CI UM560240031U — for a detailed discussion of this topic.)
- STEP 6. — The WF model must be initialized via a call to the MAS routine names "MAINIT."

### 4.3 POSTPROCESSOR INVOCATION

The postprocessor is invoked via a call to the subroutine 'POST.' The calling parameter and calling format of the routine are defined below.

```
PROCEDURE POST (VAR MODEL_NAME : STRING(75);  
                VAR DATE_TIME : STRING(75);  
                VAR USER_NAME : STRING(75);  
                VAR ORGANIZATION : STRING(75);  
                VAR STEP_VERSION : STRING(75);  
                VAR PRE_VERSION : STRING(75);  
                VAR ORIG_SYSTEM : STRING(75);  
                VAR MODEL_DESCRIPTION : STRING(75);  
                VAR RETURN_CODE : INTEGER);  
SUBPROGRAM;
```

#### 4.3.1 Parameter Definitions

Postprocessor parameter definitions are presented in Table 4-1.

TABLE 4-1.

#### POSTPROCESSOR PARAMETER DEFINITIONS

Parameter	I/O	Description
Model_Name	O	Model name extracted from EF file.
Date_Time	O	Date and Time of creation of EF file.
User_Name	O	Name of the creator of EF file.
Organization	O	Organization which created EF file.
STEP_VERSION	O	Version of the Standard which EF file conforms to.
PRE_VERSION	O	Version of the preprocessor which created the file.
ORIG_SYSTEM	O	CAD/CAM/CIM system which created the PDD.
Model_Description	O	Informal description of the PDD model.
Return_Code	O	Return Status of postprocessing step — zero implies success, non-zero implies failure.

R20463/10

## SECTION 5

### PREPROCESSING (WF TO EF) PROCEDURES

#### 5.1 INTRODUCTION

The preprocessor translates a model from the WF to the EF on the computer. This manual does not provide native system logon or terminal operating procedures because each local computing environment is unique.

It is assumed that the GMAP/PDDI software has been installed and compiled in the local computing system. (Refer to the GMAP Operator's Manual for installation details.) The remainder of this section will focus on the initialization procedures required to run the System Translator's preprocessor from a native system application.

#### 5.2 INITIALIZATION PROCEDURES

For an IBM MVS/TSO application program successfully to call the preprocessor, the steps described below must be taken.

- STEP 1. — The Data Dictionary data file must be allocated to the logical filename (DDNAME) of "DDFILE." This allocation may be done in a TSO Command List (CLIST) or in Job Control Language (JCL).
- STEP 2. — The Data Dictionary index file must be allocated to the logical filename (DDNAME) of "DDINX." This allocation may be done in a TSO Command List (CLIST) or in Job Control Language (JCL).
- STEP 3. — The EF file must be allocated to the logical filename (DDNAME) of "EFFILE." This allocation may be done in a TSO Command List (CLIST) or in Job Control Language (JCL).
- STEP 4. — Error messages are written to the logical file name (DDNAME) of "OUTPUT." The user may allocate this file to a dataset or to the terminal screen.
- STEP 5. — The GMAP System Translator is written in PASCAL and, as a result, it requires a PASCAL run-time environment to be established. The GMAP MAS User Manual provides a detailed discussion of this topic.
- STEP 6.— The WF model must be resident in computer memory and populated with PDD entities.

### 5.3 PREPROCESSOR INVOCATION

The preprocessor is invoked via a call to the subroutine "PRE." The calling parameter and calling format of the routine are defined below.

```

PROCEDURE PRE      (VAR MODEL_NAME : STRING(75);
                   VAR DATE_TIME  : STRING(75);
                   VAR USER_NAME  : STRING(75);
                   VAR ORGANIZATION : STRING(75);
                   VAR STEP_VERSION : STRING(75);
                   VAR PRE_VERSION : STRING(75);
                   VAR ORIG_SYSTEM : STRING(75);
                   VAR MODEL_DESCRIPTION : STRING(75);
                   REAL_PRECISION : INTEGER
                   VAR RETURN_CODE : INTEGER);
SUBPROGRAM;
```

#### 5.3.1 Parameter Definitions

Preprocessor parameter definitions are presented in Table 5-1.

TABLE 5-1.

#### PREPROCESSOR PARAMETER DEFINITIONS

Parameter	I/O	Description
Model_Name	O	Model name extracted from EF file.
Date_Time	O	Date and Time of creation of EF file.
User_Name	O	Name of the creator of EF file.
Organization	O	Organization which created EF file.
STEP_VERSION	O	Version of the Standard which EF file conforms to.
PRE_VERSION	O	Version of the preprocessor which created the file.
ORIG_SYSTEM	O	CAD/CAM/CIM system which created the PDD.
Model_Description	O	Informal description of the PDD model.
Real_Precision	I	Decimal Precision on Real Numbers written by the preprocessor.
Return_Code	O	Return Status of postprocessing step — zero implies success, non-zero implies failure.

R20463/10

## APPENDIX A

### UNDERSTANDING THE MAPPING FROM THE DATA DICTIONARY INTO THE WF MODEL

#### OVERVIEW

The GMAP Software System is centered on a product definition data (PDD) model that is implemented as a memory resident model called the Working Form (WF). The GMAP Data Dictionary is a physical schema file that defines how the entities and attributes are structured in the WF. The GMAP Data Dictionary is generated by the GMAP Schema Manager software from the GMAP Conceptual Schema (CS) that resulted from information modeling. The GMAP Data Dictionary can be used by application programs to gain this knowledge, or by GMAP Software System Components. The GMAP System Translator and the Name/Value Interface (NVI) are two components that utilize the GMAP Data Dictionary.

The GMAP PASCAL include file is the primary method for defining the data structure of the GMAP entities and their attributes in the WF for application programs written in PASCAL. The GMAP Data Dictionary presents the way that PASCAL stores entity data. It is intended to be used by applications written in FORTRAN, ASSEMBLER, or other languages, to define those data structures to the application.

The Data Dictionary is a set of entity definitions where each entity is defined within an alphanumeric direct access file. An entity definition in the GMAP Data Dictionary can be accessed by supplying the entity kind number to the routine "GETDD." GETDD uses an index file to locate the entity definition within the Direct Access file, and return the definition to the calling program. A detailed description of the "GETDD" user specification is provided in the NVI section of the GMAP System Components Product Specification (As Built) (CI PS560240032U).

#### WF

The data structures identified by the GMAP Conceptual Schema, and defined by the physical files, the GMAP Data Dictionary, and GMAP PASCAL include file, are implemented in the GMAP Software System as a memory resident bi-directional network known as the WF. The WF PDD model is the target of applications via either the Model Access Software (MAS) or the NVI. The nodes of the network are the entities. The basic entity structure consists of three portions, the Application Data Block (ADB), the Constituent List (CL), and the User List (UL). The UL is maintained completely by the system, and is used for the back pointers (references to other entities that are using this entity as part of their definition) in the bi-directional network. The forward pointers (references to other entities that are needed to define an entity) are maintained in the CL, and native attribute data of primitive data types or aggregations of primitive data types are stored in the ADB of an entity.

#### GMAP DATA DICTIONARY INDEX

The GMAP Data Dictionary Index file is a file that includes the name of every entity and class, the physical line number in the GMAP Data Dictionary that the definition begins on, the

number of lines that the definition encompasses in the GMAP Data Dictionary, and an indication of whether the entry is an entity or a class. The Data Dictionary Index file is used to locate the entity or class definition of interest in the GMAP Data Dictionary proper.

## **GMAP DATA DICTIONARY**

The GMAP Data Dictionary is a file of records. Each entity, or class definition, is composed of several records. There are six possible types of records that can occur in the GMAP Data Dictionary.

### **Name Records**

The name record is the first line of every entity or class definition, as shown in the example below.

- col. 1 : ' ' (blank)
- col. 2-17 : Entity or class name (16 characters)  
— The name of the entity or class.
- col. 19-23 : Kind number (5 digits)  
— The integer identifier of the entity or class kind that the system and applications use.
- col. 25-26 : number of entity attributes or class members (2 digits) not necessarily the number of records in the definition.

### **Attribute Definition Records**

The definition of an entity is comprised of many attribute records. With the exception of the first record, each record defines an attribute or part of an attribute within the entity. Different definition fields contained in each of these records are as follows:

- col. 1 : ' ' (blank)
- col. 2-17 : Attribute name (16 characters)  
— The name of this attribute.
- col. 19-20 : CS order (2 digits)  
— This field indicates the order of this attribute in the formal specification of this entity. It is this published CS order that the entity attributes will follow in the EF file.
- col. 22-23 : Physical schema order (2 digits)  
— This field indicates the order of this attribute in the computer memory resident entity. The mapping of attributes from the CS to the WF entity is not a direct mapping. The CS attributes to be put in the ADB reside at a position in the ADB that provides optimal

use of space. The mapping rules to determine a CS's attribute location in the ADB are as follows:

- Attributes that reside on double word boundaries (i.e., 8 byte reals) are first.
- Attributes that must reside on single word boundaries (i.e., 4 byte reals, and 4 byte integers) are second.
- Attributes that must reside on half word boundaries (i.e., 2 byte integers) are third.
- Attributes that must reside one byte boundaries (i.e., 1 byte integers, logicals, enumerations, and characters) are fourth.

col. 25-27 : Minimum occurrences (3 digits)

- An integer number signifying the minimum amount of data that can be stored for this attribute in increments of size. A zero (0) for this field implies that this attribute is optional. The type code (1-5) signifies that this attribute is ADB type data, zeros (0) or blank ( ) may be stored. The type code (7) signifies that this is CL type data, the single entity reference in the CL may point to a NIL entity, aggregations may point to empty ARRAY\_ENTITYs.

col. 29-30 : Number of array dimensions (2 digits)

- An integer number signifying the dimension of the array of ADB or CL data. Zero (0) implies only one instance of data.

col. 32 : Attribute data type code (1 digit)

- The Type Code field signifies the type of data this attribute contains and what part of the entity it resides in, either the ADB or CL. The types are;

1⇒ INTEGER    4⇒ LOGICAL  
2⇒ REAL       5⇒ ENUMERATION  
3⇒ STRING     7⇒ CONSTITUENT REFERENCE

- Data types 1 through 5 reside in the ADB of the entity.
- Data type 7 resides in the CL of the entity.

A detailed explanation of each of the data types is presented below.

#### 1. INTEGER

A 1, 2, or 4 byte integer.

Resides on a single byte boundary, double byte boundary or a full word boundary.

2. REAL

A 4 or 8 byte real.  
Resides on a full word boundary or a double word boundary.

3. STRING

A string of characters where each character resides in 1 byte of storage and the SIZE field signifies how many characters are present in the string.

No boundary alignment.

4. LOGICAL

A 1 byte integer such that 0  $\Rightarrow$  FALSE and 1  $\Rightarrow$  TRUE.  
No boundary alignment.

5. ENUMERATION

A 1 byte integer (0 - 255) that indexes to the scalar stored. The scalar names are enumerated later in the attribute record.  
No boundary alignment.

6. CONSTITUENT REFERENCE

Attributes of this type signify that a reference resides in the CL. The kinds of entities that this attribute can reference are enumerated later in the attribute record.

col. 34-36 : Size of ADB field in bytes (3 digits)

— An integer number signifying the number of bytes that one instance of this attribute takes in storage.

col. 38-42 : ADB displacement or CL position (6 digits)

— An integer number signifying the starting location in the ADB of the entity for this attribute or the location of this reference in the CL.

— ADB — An integer number signifying the starting location in the ADB of the entity for this attribute.

— CL — An integer number signifying the location of this reference in the CL. The domain of this attribute type is enumerated on a continuation line following the attribute.

Attribute definition records, depending on the data type of the attribute, may require further information to define. In these cases, certain kinds of continuation records are used.

based on the attribute data type. The continuation records complete the definition of the attribute, and are indicated by a continuation flag in column one of the record. There are several different kinds of continuation flags, each signaling a different kind of attribute definition continuation.

'X' — Marks a continuation line that defines additional data for ENUMERATION and CONSTITUENT REFERENCE data types.

'A' — Marks a continuation line that defines the array bounds for the previously defined attribute. An attribute can be defined in terms of a 1-n dimensional array.

### Enumeration Attribute Continuation Records

Enumeration attribute continuation records are used to complete attribute definition information for enumeration data types (data type = 5).

- col. 1 : 'X', the continuation flag.
  - col. 2-3 : Number of values to follow (2 digits)
  - col. 5-20 : Enumeration name (16 characters)
- Enumeration names are repeated, as many as four per record, in cols. 22-37, 39-54, 56-71.
- Succeeding records, if required, repeat this format, including the number of names.
- The first name corresponds to a stored value of 0, the second name corresponds to 1, and so on.

### Constituent Reference Attribute Continuation Records

Constituent reference attribute continuation records are used to complete attribute definition information for constituent reference data types (data type = 7).

- col. 1 : 'X', the continuation flag
  - col. 2-3 : Number of entity kinds (2 digits)
  - col. 5-9 : Entity kind (5 digits)
- Entity kinds are repeated, as many as 12 per record, in cols. 11-15, . . . 71-75.
- Succeeding records, if required, repeat this format, including the number of entity kinds.

### Array Bounds Records

Array bounds records are used to complete attribute definition information for aggregations of other data types.

The location of data in ADB storage for an array attribute are identical to PASCAL stores arrays. For multi-dimensional arrays, data are stored so that in the case of a three-dimensional array, the depth index is exhausted first, the column index is exhausted second, and the row index is exhausted last. This is known as row-major addressing. Note that FORTRAN uses column-major addressing, requiring the dimensions to be reversed in FORTRAN applications to address the ADB array attribute elements correctly.

Arrays for attributes that reside in the CL are stored in ARRAY ENTITYs. Further, the implementation of multi-dimensional constituent reference attribute is accomplished by the reference of ARRAY\_ENTITYs to other ARRAY\_ENTITYs until the ARRAY\_ENTITY is finally a reference to a uni-dimensional array of the base entity type.

Membership Records

col. 1 : ' ' (blank)  
col. 2- 6 : kind number (5 digits)

The GMAP Data Dictionary defines data classes as being a group of entities that are members of the class. These classes are used in the system as a type of shorthand for defining the allowable references for a given constituent reference attribute. These definitions can be used to determine if a given reference is in the set of allowable references, or can be used by an application to gather all the entities of interest to it based on a data class.

Example

A GMAP schema example detailing mapping from the GMAP Data Dictionary into the WF is presented in the example below. It is the RB\_SPLINE\_SURF entity entries in the physical files and an illustration of the memory resident network form of the entity in the WF.

GMAP Data Dictionary Index Entry:

367,RB\_SPLINE\_SURF , 605, 20,E

GMAP Data Dictionary Entry:

#####1#####2#####3#####4#####5#####6#####7#####8

```
RB_SPLINE_SURF , 367,11
KIND           , 1, 1, 1, 0,1, 4,    0
LENGTH        , 2, 2, 1, 0,1, 4,    4
SYSUSE        , 3, 3, 1, 0,1, 4,    8
IDENT         , 4, 4, 1, 0,1, 4,   12
DEGREES       , 5, 6, 1, 1,1, 2,  2016
```

**GMAP Data Dictionary Entry:**

#####1#####2#####3#####4#####5#####6#####7#####8

```

RB_SPLINE_SURF , 367,11
KIND           , 1, 1, 1, 0,1, 4,    0
LENGTH        , 2, 2, 1, 0,1, 4,    4
SYSUSE        , 3, 3, 1, 0,1, 4,    8
IDENT         , 4, 4, 1, 0,1, 4,   12
DEGREES       , 5, 6, 1, 1,1, 2,  2016

A 1, 2
  IND           , 6, 9, 1, 1,5, 1,  2024
X 6,UNDETERMINED ,LINEAR_ARC ,CIRCULAR_ARC ,ELLIPTICAL_ARC
X 6,PARABOLIC_ARC ,HYPERBOLIC_ARC
A 1, 2
  KNOTS        , 7, 5, 2, 2,2, 8,   16
A 1, 2, 1,125
  NO_KNOTS_U   , 8, 7, 1, 0,1, 2,  2020
  NO_KNOTS_V   , 9, 8, 1, 0,1, 2,  2022
  PERIODIC     ,10,10, 1, 1,4, 1,  2026
A 1, 2
  CTRL_PTS     ,11, 0, 4, 2,7, 4,    1
X 1, 347
A 1,125, 1,125

```

#####1#####2#####3#####4#####5#####6#####7#####8

Working Form:

<u>ADB ADDRESS</u>	<u>SUBSCRIPT or VALUE</u>	<u>ATTRIBUTE NAME</u>	<u>ATTRIBUTE TYPE</u>
0	367	KIND	INTEGER*4
4	2028	LENGTH	INTEGER*4
8	0	SYSUSE	INTEGER*4
12	-	IDENT	INTEGER*4
16	(1,1)	KNOTS	ARRAY (2,125) of REAL*8
24	(1,2)	KNOTS	
.	.	.	
.	.	.	
1008	(1,125)	KNOTS	
1016	(2,1)	KNOTS	
1024	(2,2)	KNOTS	
.	.	.	
.	.	.	
2008	(2,125)	KNOTS	
2016	(1)	DEGREES	ARRAY (2) of INTEGER
2018	(2)	DEGREES	
2020	-	NO_KNOTS_U	INTEGER*4
2022	-	NO_KNOTS_V	INTEGER*4
2024	(1)	IND	ARRAY (2) of ENUMERATION
2025	(2)	IND	
2026	(1)	PERIODIC	ARRAY (2) of LOGICAL
2027	(2)	PERIODIC	

<u>CONSTITUENT LIST POSITION</u>	<u>CONSTITUENT LIST REFERENCE</u>	<u>ATTRIBUTE NAME</u>
1	ARRAY_ENTITY	CTRL_PTS

Note that the first three attributes in the WF entity (KIND, LENGTH, SYSUSE), are required by the GMAP software system for overhead, and are present for all entities. The KIND number is a unique integer identifier for each entity type in the system. LENGTH is the total number of ADB bytes of storage that the particular entity utilizes. SYSUSE is an integer used as system flags for various marking purposes. The fourth attribute, IDENT, is added for all entities in the GMAP system, but is not required by the system. It is the instance number of the specific kind of entity. The IDENT is used in conjunction with the KIND number to uniquely identify a certain instance of an entity for human purposes, such as 367-1 (being the first occurrence in the product model of a RB\_SPLINE\_SURF entity), and is convenient in specification of product models. Note that the system itself tracks the entities by a unique entity key number, and is part of the WF overhead for each entity.

Also, note that in the CL for the RB\_SPLINE\_SURF is a constituent reference to an ARRAY\_ENTITY. The attribute CTRL\_PTS is a 125 by 125 array of references to CTRL\_PT entities. The ARRAY\_ENTITY in CL position 1 will then point to up to 125 other ARRAY\_ENTITYs which will in turn each point to up to 125 CTRL\_PT entities, thus establishing a two dimensional set of references to CTRL\_PTs as CTRL\_PTS for the RB\_SPLINE\_SURF.

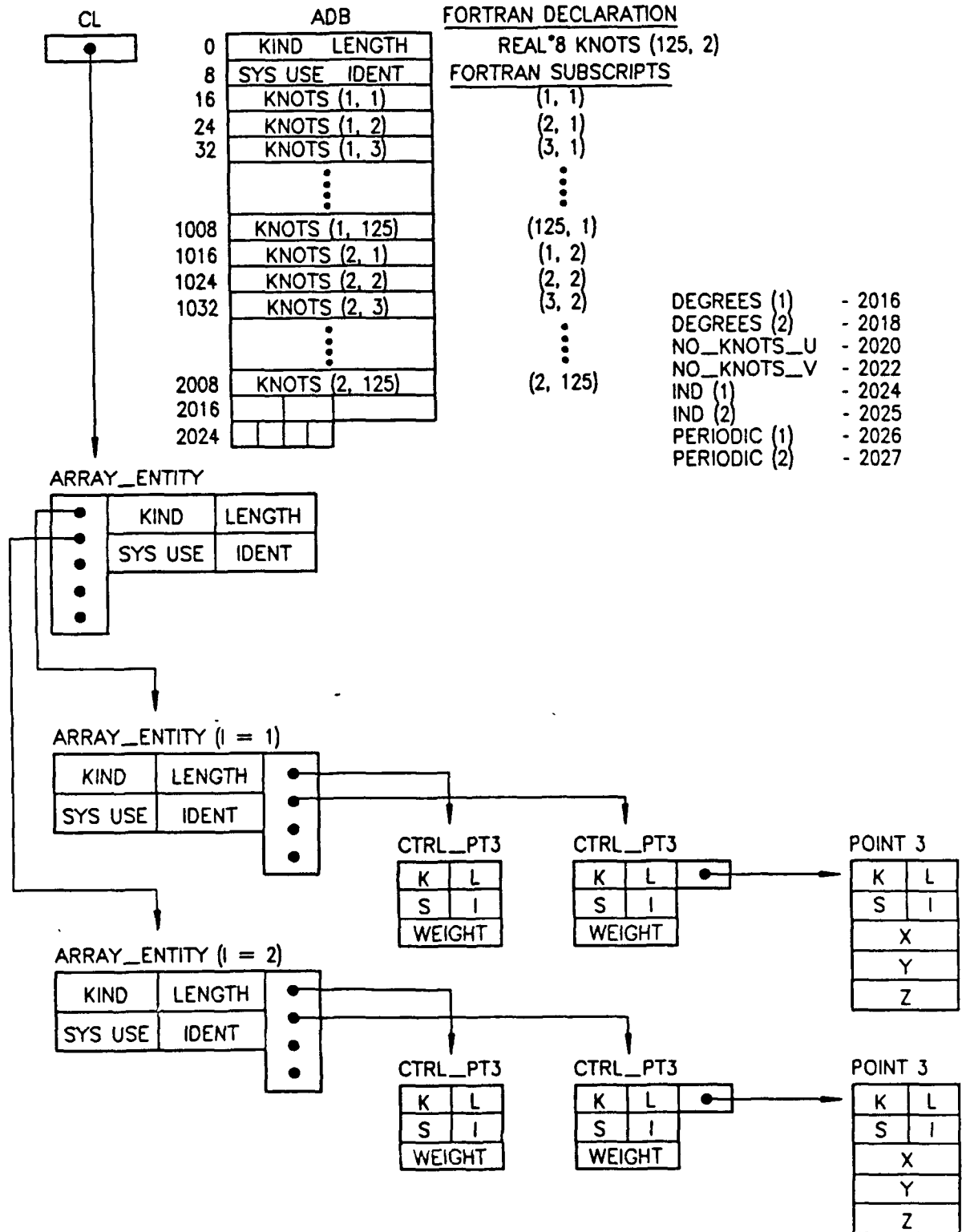

FD 357866