

DTIC FILE COPY

Naval Research Laboratory

Washington, DC 20375-5000



NRL Memorandum Report 6717

AD-A228 174

Reaction Propagation Studies in Beam-Initiated Confined Explosives

A. STOLOVY, J. M. KIDD AND A. I. NAMENSON

*Directed Energy Effects Branch
Condensed Matter and Radiation Sciences Division*

October 8, 1990

DTIC
ELECTE
NOV 02 1990
S E D

REPORT DOCUMENTATION PAGE			Form Approved OMB No. 0704-0188	
Public reporting burden for this collection of information is estimated to average 1 hour per response, including the time for reviewing instructions, searching existing data sources, gathering and maintaining the data needed, and completing and reviewing the collection of information. Send comments regarding this burden estimate or any other aspect of this collection of information, including suggestions for reducing this burden, to Washington Headquarters Services, Directorate for Information Operations and Reports, 1215 Jefferson Davis Highway, Suite 1204, Arlington, VA 22202-4302, and to the Office of Management and Budget, Paperwork Reduction Project (0704-0188), Washington, DC 20503				
1. AGENCY USE ONLY (Leave blank)	2. REPORT DATE 1990 October 8	3. REPORT TYPE AND DATES COVERED FINAL		
4. TITLE AND SUBTITLE Reaction Propagation Studies in Beam-Initiated Confined Explosives			5. FUNDING NUMBERS PE - 61153N TA - RR012-01-41 WU - 46-1788-00	
6. AUTHOR(S) A. Stolovy, J. M. Kidd and A. I. Namenson				
7. PERFORMING ORGANIZATION NAME(S) AND ADDRESS(ES) Naval Research Laboratory Washington, DC 20375-5000			8. PERFORMING ORGANIZATION REPORT NUMBER NRL Memorandum Report 6717	
9. SPONSORING/MONITORING AGENCY NAME(S) AND ADDRESS(ES)			10. SPONSORING/MONITORING AGENCY REPORT NUMBER	
11. SUPPLEMENTARY NOTES				
12a. DISTRIBUTION / AVAILABILITY STATEMENT Approved for public release; distribution unlimited.			12b. DISTRIBUTION CODE	
13. ABSTRACT (Maximum 200 words) Experiments have been performed with the electron beam at the NRL Linac in which confined explosives were partially irradiated to study how the reaction spreads radially from the hot central region to the cool outer regions. Four types of high explosives (HE) were studied: PBX-9404, PBXW-109, HBX-1, and TATB. Data were obtained with two sets of beam pulse parameters, and as a function of confinement window thickness. The results vary widely, from no reaction spreading at all in TATB to complete spreading and consumption in PBX-9404. The violence of the explosion increases with increasing confinement. <i>Reaction products, some of which are hazardous, are contained within the vessel.</i>				
14. SUBJECT TERMS			15. NUMBER OF PAGES 19	
			16. PRICE CODE	
17. SECURITY CLASSIFICATION OF REPORT UNCLASSIFIED	18. SECURITY CLASSIFICATION OF THIS PAGE UNCLASSIFIED	19. SECURITY CLASSIFICATION OF ABSTRACT UNCLASSIFIED	20. LIMITATION OF ABSTRACT UL	

CONTENTS

INTRODUCTION	1
EXPERIMENTAL PROCEDURE	1
RESULTS	3
A. TATB	3
B. HBX-1	3
C. PBXW-109	4
D. PBX-9404	4
CONCLUSIONS	5
ACKNOWLEDGEMENTS	6
REFERENCES	6

..... ion For	
..... CRA&I	<input checked="" type="checkbox"/>
..... TIC TAB	<input type="checkbox"/>
..... nounced	<input type="checkbox"/>
Justification	
By _____	
Distribution/	
Availability Codes	
List	Avail and/or Special
A-1	



REACTION PROPAGATION STUDIES IN BEAM-INITIATED CONFINED EXPLOSIVES

INTRODUCTION

In recent years, the thresholds for thermal initiation of a variety of high explosives (HE), primary explosives and propellants have been measured to good accuracy ($\sim 5\%$) using both proton and electron beams.^{1,2,3} The equivalence of initiation by proton and electron beams has been demonstrated.⁴ In these experiments, confined HE disks were heated uniformly in both depth and profile by using samples which were smaller than the beam cross section. In the present series of experiments, the beam is collimated, and a much larger HE sample disk is used so that the beam irradiates only the central portion of the confined HE. Our objective is to study how (or if) reactions initiated in the irradiated region propagate into the surrounding cooler regions. The experiments are designed to simulate on a small scale the situation in which a proposed particle beam weapon irradiates an HE target non-uniformly. This could occur for several reasons, such as absorption of the beam by intervening materials (shadowing), an off-center shot, or a beam size smaller than the target.

EXPERIMENTAL PROCEDURE

The electron beam at the NRL Linac is used to irradiate and heat to initiation the central portion of the HE disks (1 inch diameter x 1/4 inch thick), as shown in Figure 1. The HE is tightly confined via an O-ring and 12 bolts, and thermally insulated via ceramic paper. A 3/8-inch thick aluminum plate protects the accelerator window from blast fragments. The exit window behind the HE sample was machined to various thicknesses (from 1/32 inch to 1/4

Manuscript approved September 6, 1990.

inch) to vary the confinement. An aluminum disk with an attached thermocouple was placed in the re-entrant hole as shown, to serve as a calorimeter (or dosimeter). The hole in the beam collimator was 1/4 inch in diameter in some runs, and 1/2 inch in others. Four chromel-alumel thermocouples are imbedded in the rear of each HE disk, one at the center and three peripheral ones, as shown in Figure 2. These could yield information on how rapidly the reaction spreads. Data acquisition is via a computer and a chart recorder.

A total of 15 tests were performed on four types of HE under a variety of beam parameter, collimator and confinement conditions, during two test periods. A test matrix listing these conditions and the materials studied is given in Table 1. One set of tests was performed with a 23-MeV beam and a peak pulse

TABLE 1. REACTION PROPAGATION TEST MATRIX AT THE NRL LINAC

HE	Tests	Beam Parameters [*]		Collimator	Exit Window
		Energy (MeV)	Current (mA)	Diameter (in.)	Thickness (in.)
TATB	2	23	240	0.25	0.032
HAX-1	3	"	"	"	"
PBXW-109	1	"	"	"	"
PBXW-109	5	50	120	0.5	0.094, 0.120 1.130, 0.188 0.250
PBX-9404	4	"	"	"	0.063, 0.94 0.125, 0.125

* 1.5 μ s width, 360 pulses/sec

current of 240 μ amp. A Monte Carlo calculation indicates that under these conditions, the rear face of the HE receives about 2/3 the dose at the front face.⁵ The other tests were done with a more penetrating 50-MeV beam, but with

half the pulse current. These trade-offs are dictated by the limitations of the accelerator. All tests were done with 1.5 μ sec pulses, and a repetition rate of 360 pulses/sec. This produces a heating rate of about 3 cal/g.s for the central region (corresponding to a dose rate of about 1.3 MRad/s). This produces a thermal explosion in 20 to 30 sec in most of the HE materials studied.

The beam profile incident upon the collimator face is compared to the two collimator hole diameters used in Figure 3.

RESULTS

A. TATB

Two tests were performed with 23-MeV, 240 mAmp beam pulses, a 1/4-inch diameter collimated beam, and 1/32-inch thick Al exit window. The thermocouple data indicate that in one test the central region went exothermic, but did not rupture the exit window. In the other test, explosion occurred, expelling unreacted powder explosive, with little damage. In neither case did the reaction spread beyond the beam irradiated region.

B. HBX-1

This mixture contains RDX, TNT, Al powder and wax. Three tests were performed under the same conditions as the TATB tests above. In all three cases, explosion and rupture of the exit window occurred. Upon disassembly of the confinement cells, we found that only the central, irradiated region was consumed. The explosion produced several large radial cracks in the remaining HE, but most of explosive remained unreacted, as shown in Figure 4. Thermocouple records of the center and three side regions are shown in Figure 5. Heating from the explosion seems to be anisotropic; one channel shows no heating at all.

C. PEXW-109

This formulation contains RDX, Al powder and binders. One test was performed under the same conditions as above. An explosion occurred, but there was no evidence for reaction or consumption of material outside of the irradiated region (see Figure 6). Five more tests were done with 50-MeV, 120 mAmp pulses, a 1/2-inch diameter collimated beam and Al exit window thicknesses from 3/32 inch to 1/4 inch thick (see Table 1). An explosion occurred in all cases, but the rear window ruptured in only two tests. The amount of HE consumed varied from 25% (the irradiated region) to about 80%. Evidence for HE consumption beyond the irradiated region was seen in 3 tests. There seems to be no correlation between the percent HE consumed and the confinement window thickness. In one case, the pulse repetition rate was inadvertently set at 180/sec (half the usual rate). This resulted in a rather weak explosion, with little HE consumption. The average initiation threshold was found to be 79 ± 2 cal/g, from the calorimeter data.

D. PBX-9404

Four tests were performed with this HE (94% HMX), with 50-MeV, 120 mAmp pulses, a beam collimator diameter of 1/2 inch, and Al confinement window thicknesses from 1/16 inch to 1/8 inch (see Table 1). In all of these tests, the reaction spread and consumed all of the HE, resulting in violent explosions. For the tests with the thinner confinement windows (1/16 inch and 3/32 inch), the windows were ruptured and the back plate distorted. For the two tests with 1/8-inch thick windows, the entire back plate was ripped out. From the calorimeter data, we obtain an average initiation threshold of 78 ± 4 cal/g.

Figures 7 and 8 show thermocouple records for the central region and one of the side locations, respectively. Exothermic activity begins where the

temperature rises above the beam heating straight line. From the time difference between this start for the central and side regions, we infer that the reaction spreads quite slowly (~ 0.05 in/sec) below the initiation temperature. However, the explosion appears to occur simultaneously in all regions (within the 40 msec time response of the thermocouples).

CONCLUSIONS

A. The most important factor determining how a beam-induced chemical reaction will spread is the sensitivity of the HE. Reaction propagation varies from complete consumption in PBX-9404 (and probably other HE formulations with a high percentage of HMX) to no propagation at all in TATB. Other formulations containing TNT and/or RDX fall somewhere in between.

B. There is evidence that below the initiation temperature the reaction spreads radially quite slowly (~ 0.05 in/sec) in PBX-9404. Upon initiation, however, the reaction spreads very rapidly to explosion; within instrumental resolution, the explosion appears simultaneously in all thermocouple records.

C. The thermocouple data indicate that reaction spreading is often not isotropic.

D. The violence of the explosion seems to increase with confinement. This is probably as expected. However, the data on PBXW-109 do not clearly support the proposition that the percent of HE consumed should increase with confinement.

E. Thresholds for initiation in these experiments are about 10% to 20% higher than thresholds we obtained for uniform beam heating.¹ This is probably due to heat diffusing away from the central region to the cooler regions of the HE.

Calculations have been done by J.B. Aviles based upon a model he has developed to fit these experimental results. This will be published as a separate report.

ACKNOWLEDGEMENTS

We wish to thank Dr. J.B. Aviles for many useful discussions, and Dr. M.I. Haftel for performing Monte Carlo calculations on the beam deposition profile.

This work was sponsored by the Defense Nuclear Agency, and managed by the Air Force Weapons Laboratory.

REFERENCES

1. A. Stolovy, A.I. Namenson, J.B. Aviles, Jr., E.C. Jones, Jr., and J.M. Kidd
J. of Ener. Mat. 5, 181 (1987).
2. A. Stolovy and J.M. Kidd, NRL Memo. Report 6558, Sept 22, 1989.
3. A. Stolovy, A.I. Namenson, and J.M. Kidd, NRL Memo. Report 6646,
May 17, 1990.
4. A. Stolovy, J.M. Kidd, and A.I. Namenson, in Proceedings of the Second
Neutral Particle Beam Technical Symposium, 20-24 May 1990, San Diego,
CA (to be published).
5. M.I. Haftel, unpublished.

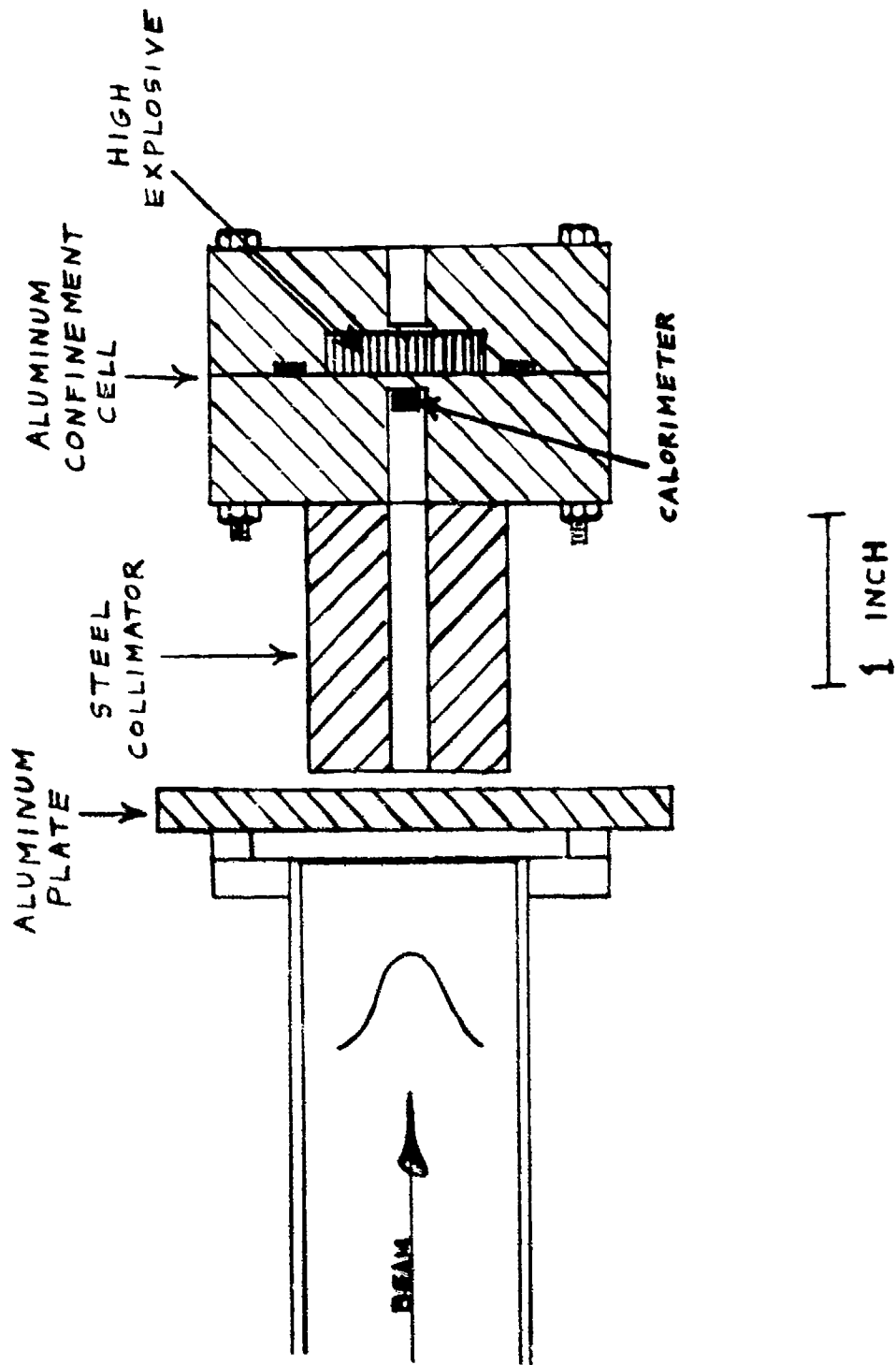

Fig. 1 — Experimental arrangement for studying reaction propagation in a confined high explosive. A collimated electron beam heats only the central region of the explosive disk

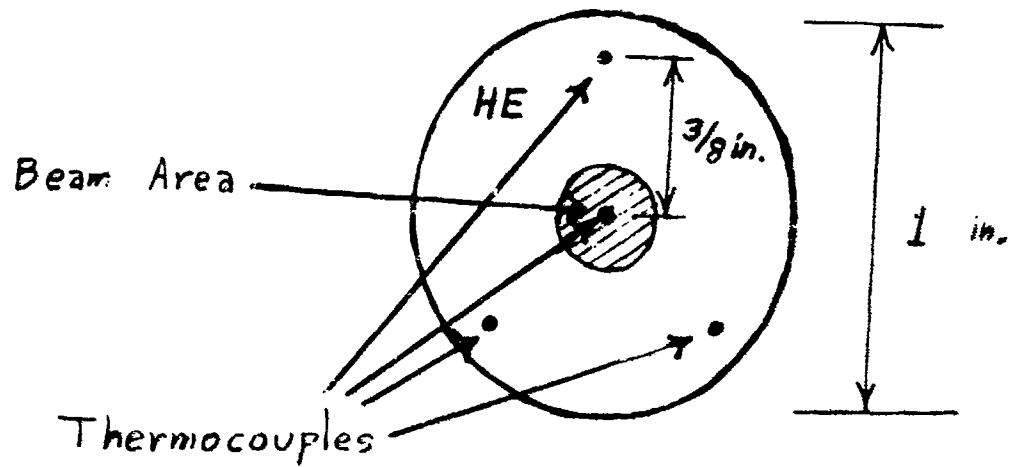

Fig. 2 — Placement of thermocouples on the rear face of the explosive

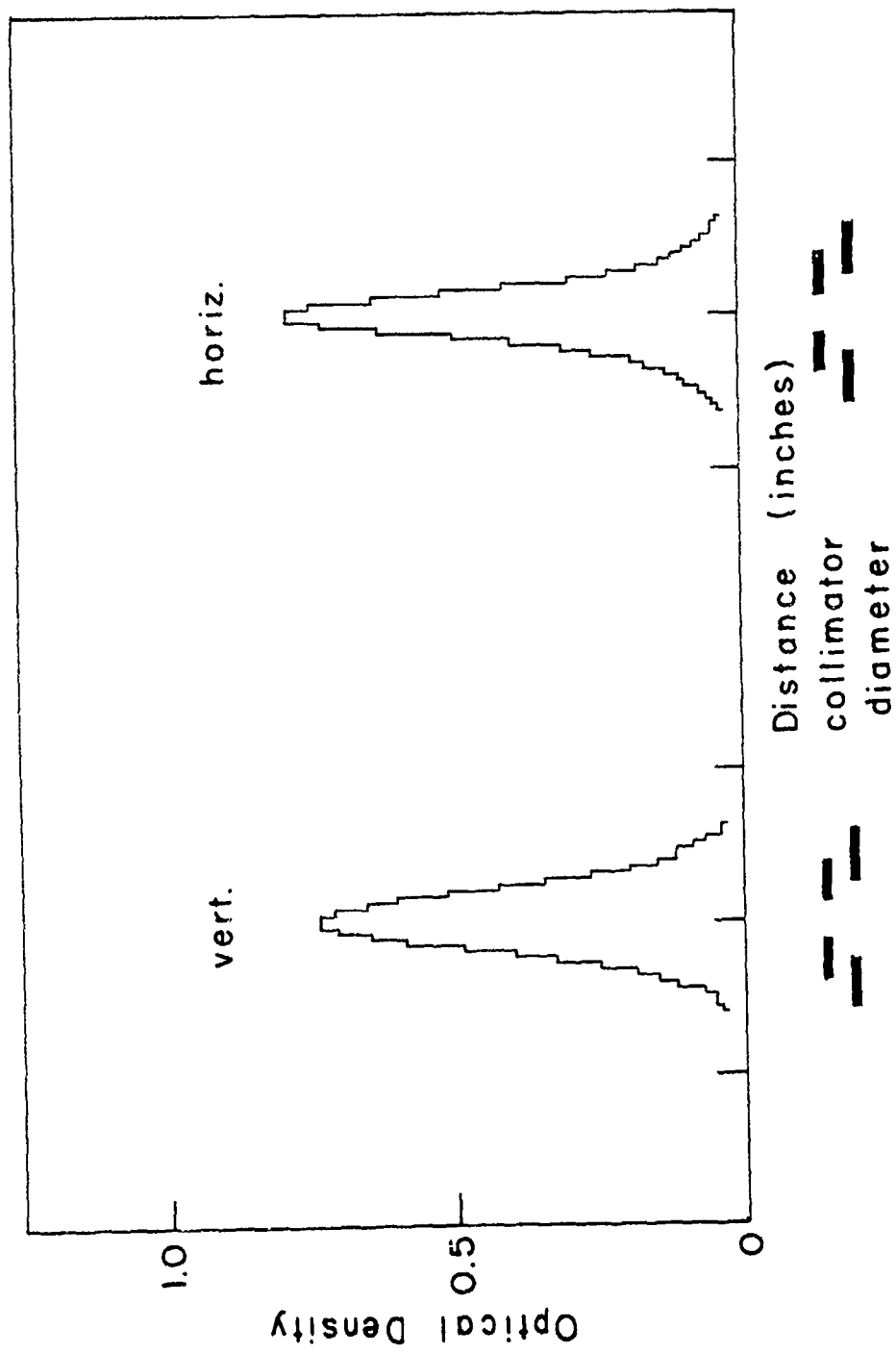

Fig. 3 — Horizontal and vertical beam profile incident on the collimator, measured via radiachromic film exposure to 200 pulses. The two collimator hole diameters used (1/4 inch and 1/2 inch) are indicated for comparison

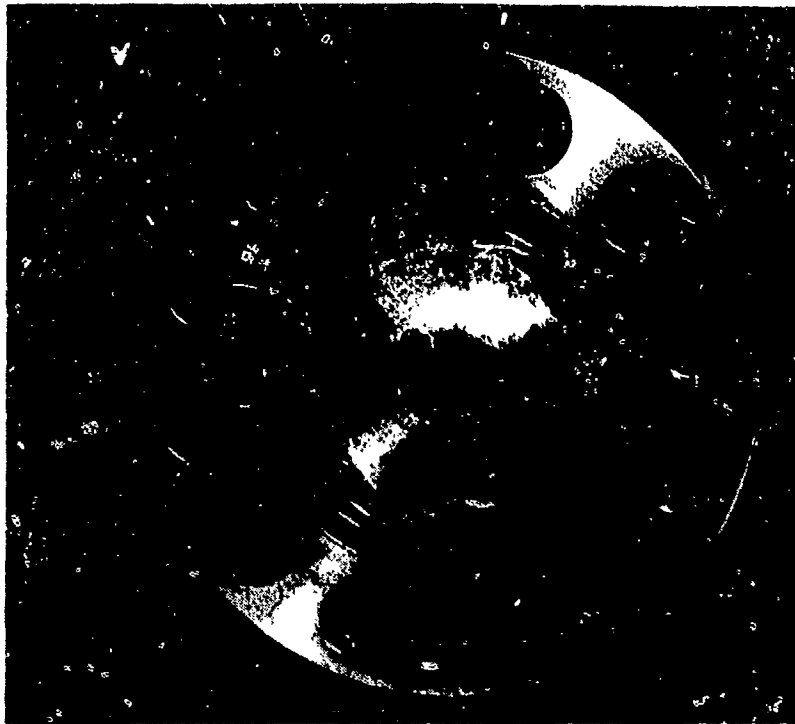

Fig. 4 — Confinement cell rear plate after explosion of HBX-1 sample, showing that most of the HE remained unreacted

HBX-1

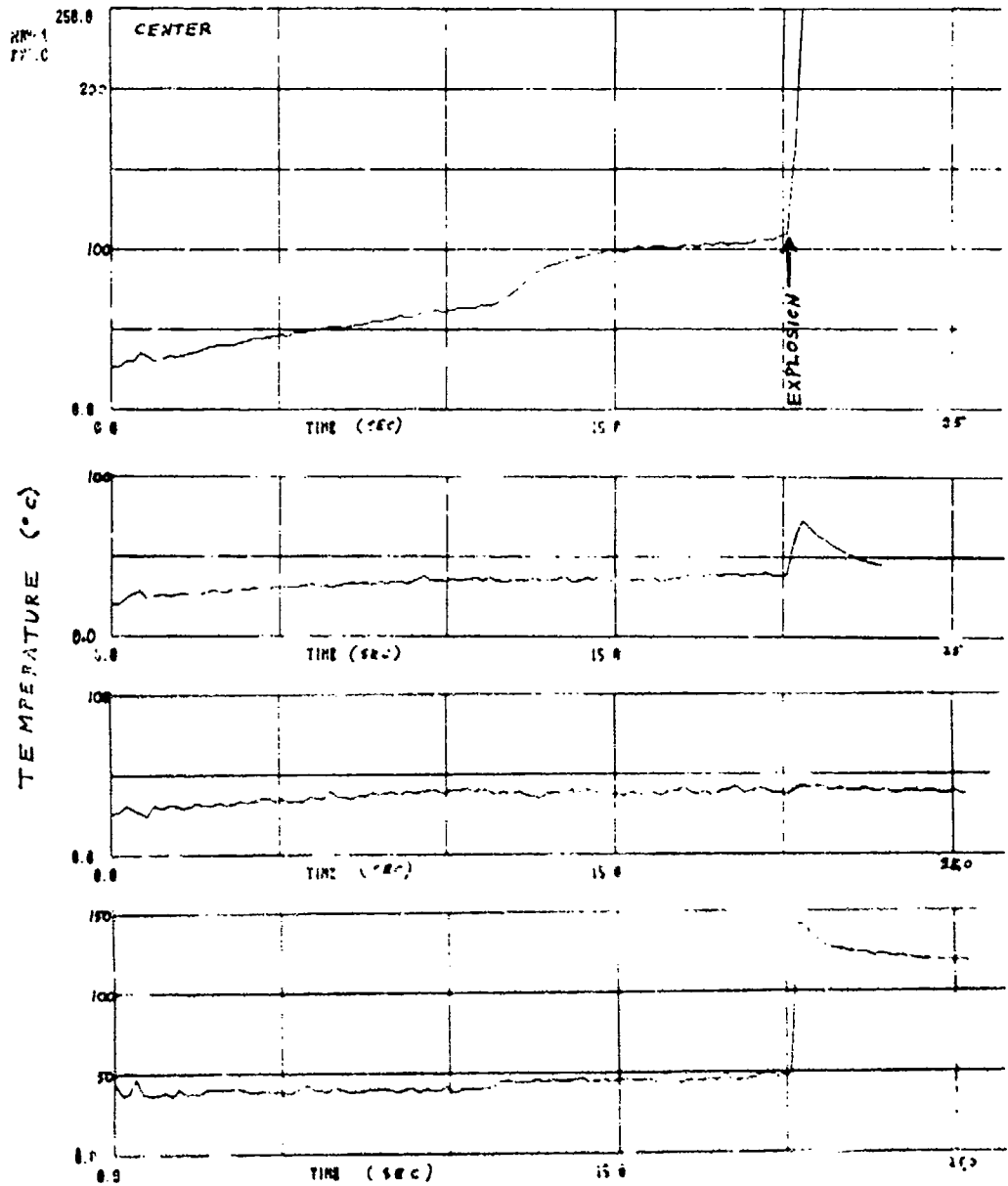

Fig. 5 — Thermocouple records for the center (top), and the three peripheral locations, showing that heat from the explosion of an HBX-1 sample spread anisotropically

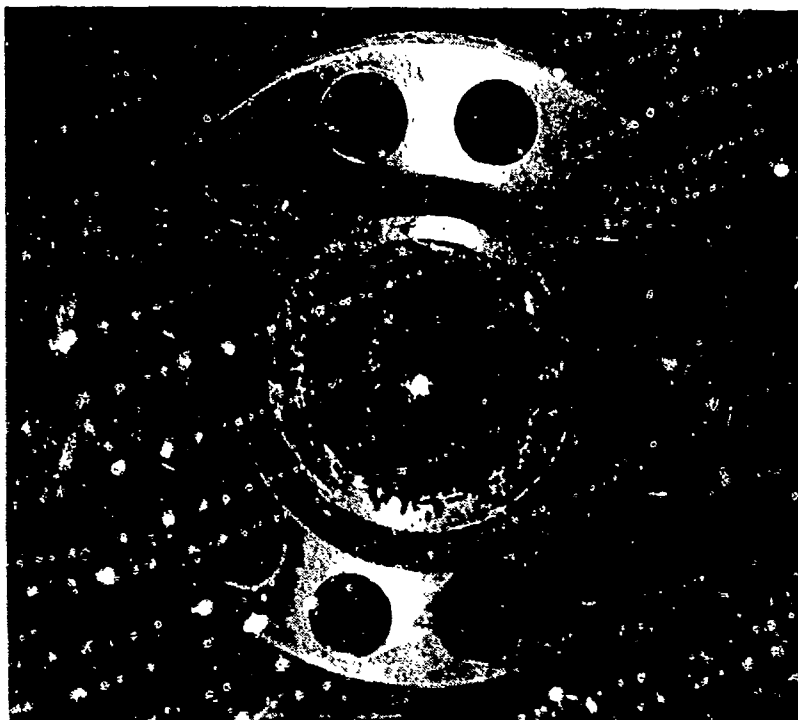

Fig. 6 - Confinement cell rear plate after explosion of PBXW-109 sample (65% RDX), showing that only the central irradiated region was consumed

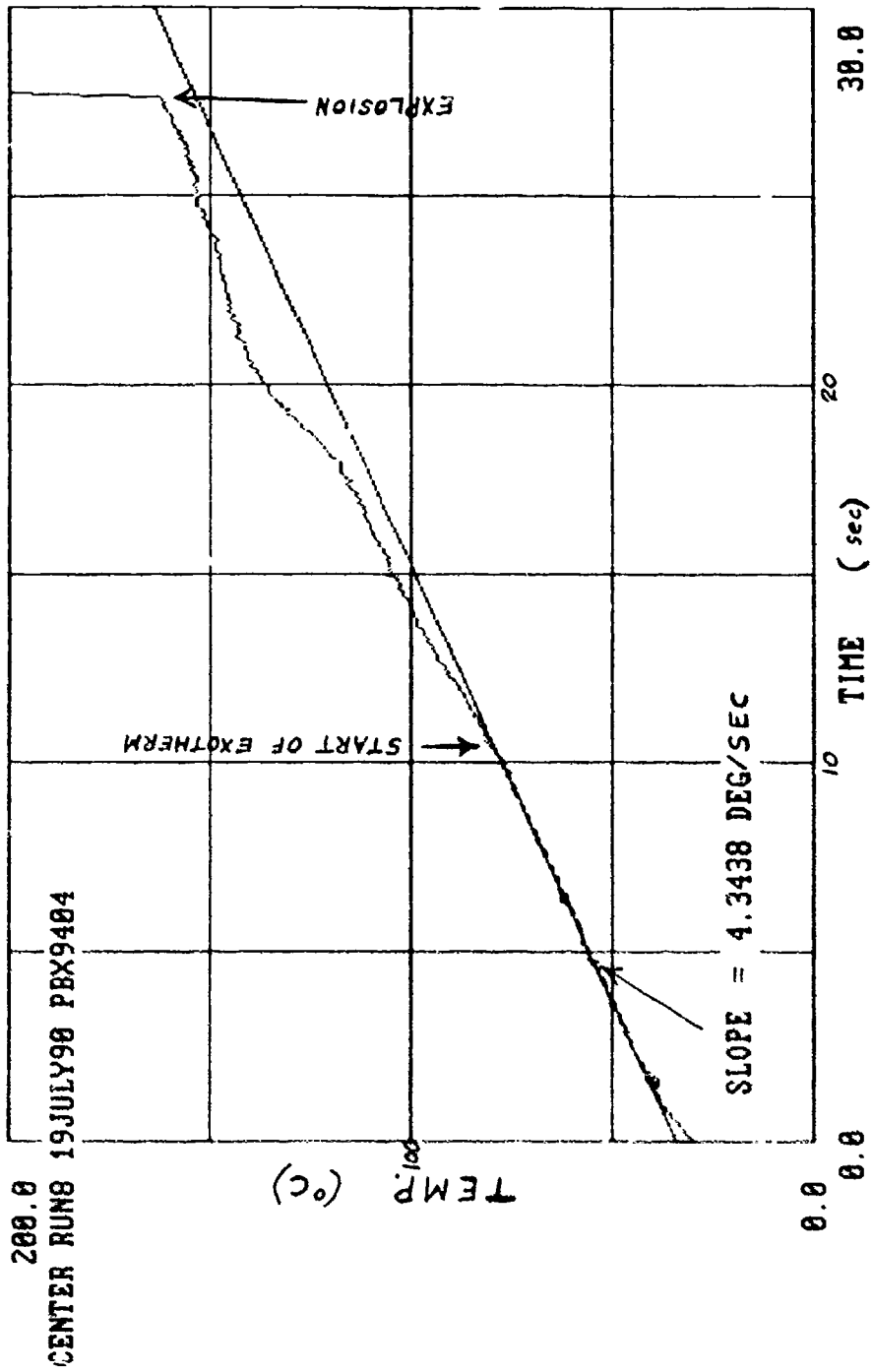

Fig. 7 — Thermocouple record for the central region of a PBX-9404 sample (94% HMX), showing the start of exothermic activity at about 10.5 sec. and explosion at 27.6 sec

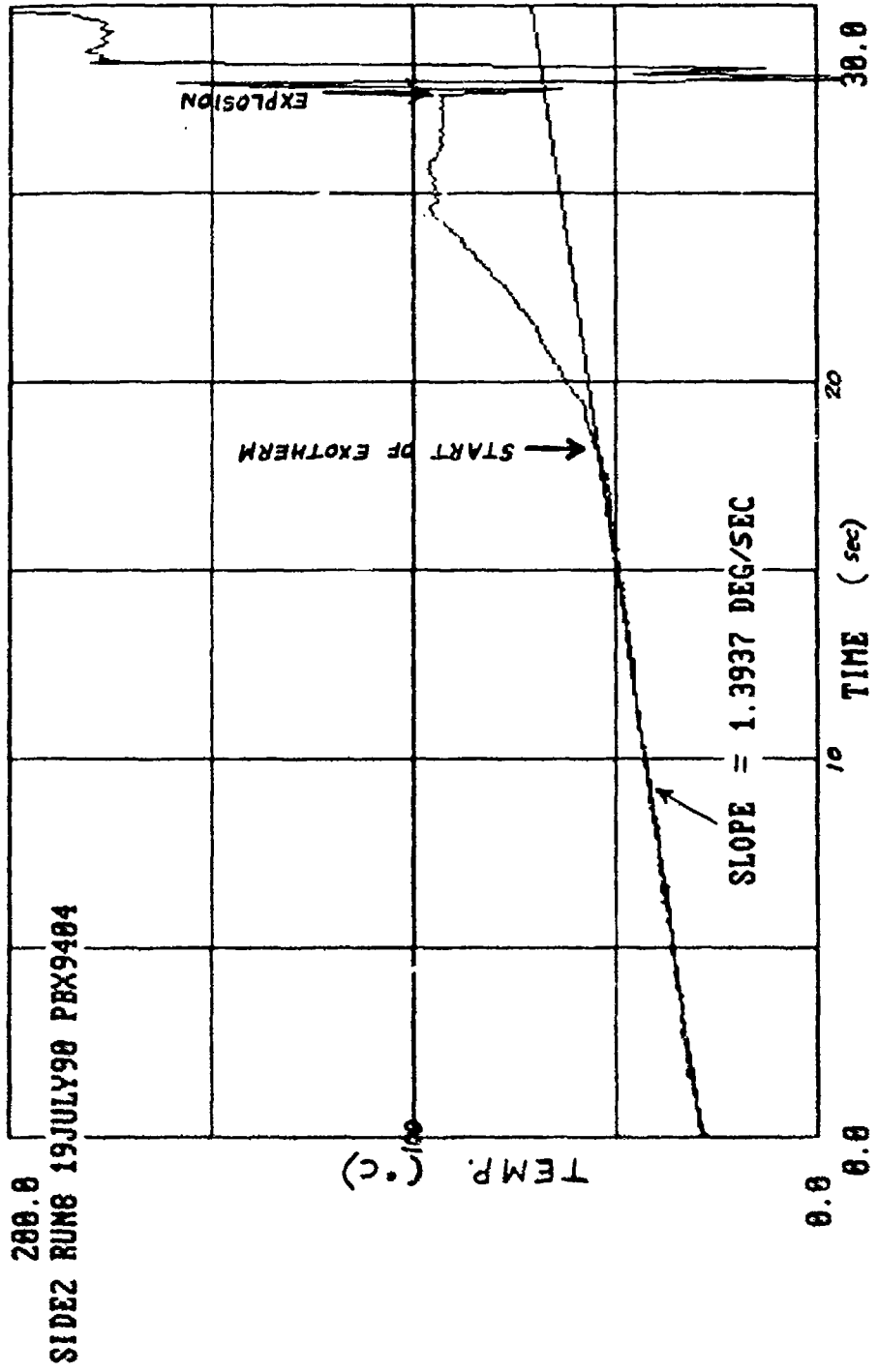

Fig. 8 -- Thermocouple record for a peripheral location of the same sample as in Fig. 7. Exothermic activity begins much later (18.2 sec), but explosion occurs simultaneously with the center (27.6 sec).