

Report No. CG-D-12-90

AD-A229 103

TEST AND DEVELOPMENT
OF A
MICROPROCESSOR CONTROLLED CYCLE-CHARGING
DIESEL POWER SYSTEM
FOR
REMOTE LIGHTHOUSE APPLICATIONS

WARREN HEERLEIN

U.S. COAST GUARD
RESEARCH AND DEVELOPMENT CENTER
AVERY POINT
GROTON, CONNECTICUT 06340-6096



INTERIM REPORT
NOVEMBER 1989

DTIC
ELECTE
NOV 30 1990
S B D

This document is available to the U.S. public through the
National Technical Information Service, Springfield, Virginia 22161

Prepared for:

U.S. Department Of Transportation
United States Coast Guard
Office of Engineering, Logistics, and Development
Washington, DC 20593-0001

NOTICE

This document is disseminated under the sponsorship of the Department of Transportation in the interest of information exchange. The United States Government assumes no liability for its contents or use thereof.

The United States Government does not endorse products or manufacturers. Trade or manufacturers' names appear herein solely because they are considered essential to the object of this report.

The contents of this report reflect the views of the Coast Guard Research and Development Center, which is responsible for the facts and accuracy of data presented. This report does not constitute a standard, specification, or regulation.

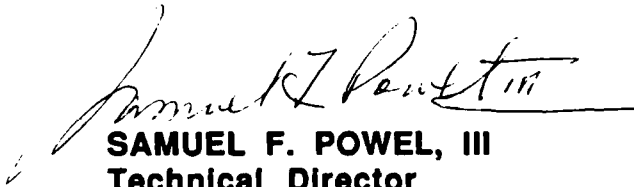

SAMUEL F. POWEL, III
Technical Director
U.S. Coast Guard Research and Development Center
Avery Point, Groton, Connecticut 06340-6096



Technical Report Documentation Page

1. Report No. CG-D-12-90		2. Government Accession No.		3. Recipient's Catalog No.	
4. Title and Subtitle TEST AND DEVELOPMENT OF A MICROPROCESSOR CONTROLLED CYCLE-CHARGING DIESEL POWER SYSTEM FOR REMOTE LIGHTHOUSE APPLICATIONS				5. Report Date NOVEMBER 1989	
				6. Performing Organization Code	
				8. Performing Organization Report No. R&DC 04/89	
7. Author(s) Warren Heerlein				10. Work Unit No. (TR AIS)	
9. Performing Organization Name and Address U.S. Coast Guard Research and Development Center Avery Point Groton, Connecticut 06340-6096				11. Contract or Grant No.	
				13. Type of Report and Period Covered INTERIM REPORT	
12. Sponsoring Agency Name and Address Department of Transportation U.S. Coast Guard Office of Engineering, Logistics, and Development Washington, D.C. 20593-0001				14. Sponsoring Agency Code	
				15. Supplementary Notes	
16. Abstract					
<p>The Coast Guard operates over 30 remote lighthouses with diesel generator sets. The generators are reliable, but system improvements are being sought for two reasons: (1) deployments for routine engine maintenance are expensive; and (2) the variance between peak and average load power is large, causing inefficiency in the engine. A prototype power plant was designed that addressed these issues. It operates a genset at an efficient level and uses excess power to charge a battery. The diesel engine is turned off periodically and the charged battery assumes the load. This uniformly reduces engine hours and allows maintenance visits to be scheduled less frequently.</p> <p>The design is unique because it uses an algorithm to determine charge acceptance of the battery. In place of a conventional battery charger, a microprocessor based controller is used to adjust the generator's voltage regulator. The charge algorithm is programmed into this controller and used to determine and control precise charge currents. This should minimize water loss and prolong battery life. The system successfully operated a 4 kilowatt load at a nominal 120 volts but the algorithm required modifications that were contrary to its purpose.</p>					
17. Key Words			18. Distribution Statement		
diesel engine battery cycle charging			algorithm microprocessor state of charge		
			Document is available to the U.S. public through the National Technical Information Service, Springfield, Virginia 22161		
19. Security Classif. (of this report)		20. SECURITY CLASSIF. (of this page)		21. No. of Pages	22. Price
UNCLASSIFIED		UNCLASSIFIED			

METRIC CONVERSION FACTORS

Approximate Conversions to Metric Measures

Symbol	When You Know	Multiply By	To Find	Symbol
LENGTH				
in	inches	* 2.5	centimeters	cm
ft	feet	30	centimeters	cm
yd	yards	0.9	meters	m
mi	miles	1.6	kilometers	km
AREA				
in ²	square inches	6.5	square centimeters	cm ²
ft ²	square feet	0.09	square meters	m ²
yd ²	square yards	0.8	square meters	m ²
mi ²	square miles	2.6	square kilometers	km ²
	acres	0.4	hectares	ha
MASS (WEIGHT)				
oz	ounces	28	grams	g
lb	pounds	0.45	kilograms	kg
	short tons (2000 lb)	0.9	tonnes	t
VOLUME				
tsp	teaspoons	5	milliliters	ml
tbsp	tablespoons	15	milliliters	ml
fl oz	fluid ounces	30	milliliters	ml
c	cups	0.24	liters	l
pt	pints	0.47	liters	l
qt	quarts	0.95	liters	l
gal	gallons	3.8	liters	l
ft ³	cubic feet	0.03	cubic meters	m ³
yd ³	cubic yards	0.76	cubic meters	m ³
TEMPERATURE (EXACT)				
°F	Fahrenheit temperature	5/9 (after subtracting 32)	Celsius temperature	°C

* 1 in = 2.54 (exactly) For other exact conversions and more detailed tables, see NBS Misc. Publ. 286, Units of Weights and Measures. Price \$2.25. SD Catalog No. C13 10 286

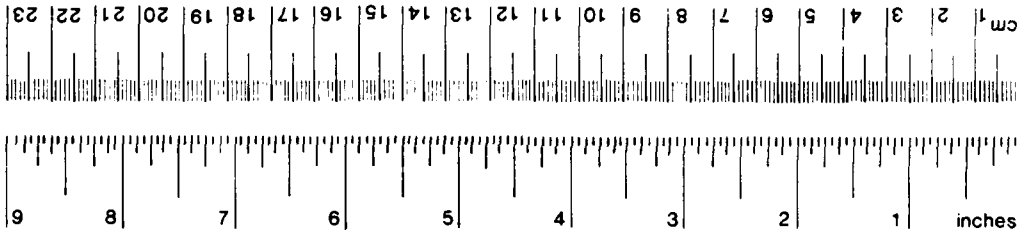

Approximate Conversions from Metric Measures

Symbol	When You Know	Multiply By	To Find	Symbol
LENGTH				
mm	millimeters	0.04	inches	in
cm	centimeters	0.4	inches	in
m	meters	3.3	feet	ft
m	meters	1.1	yards	yd
km	kilometers	0.6	miles	mi
AREA				
cm ²	square centimeters	0.16	square inches	in ²
m ²	square meters	1.2	square yards	yd ²
km ²	square kilometers	0.4	square miles	mi ²
ha	hectares (10,000 m ²)	2.5	acres	
MASS (WEIGHT)				
g	grams	0.035	ounces	oz
kg	kilograms	2.2	pounds	lb
t	tonnes (1000 kg)	1.1	short tons	
VOLUME				
ml	milliliters	0.03	fluid ounces	fl oz
l	liters	0.125	cups	c
l	liters	2.1	pints	pt
l	liters	1.06	quarts	qt
l	liters	0.26	gallons	gal
m ³	cubic meters	35	cubic feet	ft ³
m ³	cubic meters	1.3	cubic yards	yd ³
TEMPERATURE (EXACT)				
°C	Celsius temperature	9/5 (then add 32)	Fahrenheit temperature	°F

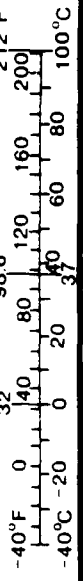

TABLE OF CONTENTS

	<u>Page</u>
ACKNOWLEDGMENTS	x
INTRODUCTION	1
PURPOSE.....	1
BACKGROUND.....	1
OBJECTIVES	2
DESIGN	4
GUIDELINES.....	4
TEST PLAN.....	4
CONSTRAINTS.....	4
COMMERCIAL ALTERNATIVES.....	6
COMPONENTS DESCRIPTION.....	7
MAJOR NEW COMPONENTS SELECTION.....	7
Battery	7
Rectifier	7
Power Transformers	90
Inverters	13
Load Suite	13
OPERATION	13
PSM (System Controller).....	15
CHARGE CONTROLLER	17
Algorithm Specifics	19
ENGINE CONTROLLER	23

TABLE OF CONTENTS (cont'd)

	<u>Page</u>
RESULTS	24
PERFORMANCE BACKGROUND.....	24
RELIABILITY.....	24
CYCLES.....	26
ENGINE DUTY CYCLE.....	27
CHARGE/DISCHARGE TIMES.....	27
FUEL USAGE.....	27
GENERATOR POWER.....	29
BATTERY EFFICIENCY.....	29
SYSTEM EFFICIENCY.....	29
CONCLUSIONS	31
DISCUSSION	31
PROBLEM AREAS.....	31
ELECTROLYTE MAINTENANCE.....	31
SOFTWARE REVISIONS.....	34
FUTURE FACTORS.....	34
GENERAL.....	35
BATTERY COSTS.....	36
OTHER BENEFITS.....	36
BATTERY SELECTION.....	37
RECOMMENDATIONS	40
REFERENCES	R-1

TABLE OF CONTENTS (cont'd)

	<u>Page</u>
APPENDIX A. - CYCLE CHARGE PROTOTYPE COMPONENTS.....	A-3
APPENDIX B - SUB-TEST DETAILS.....	B-3
Sub-test #1	B-3
Sub-test #2	B-3
Sub-test #3	B-3
Sub-test #4	B-6
Sub-test #5	B-8
Sub-test #6	B-14
Sub-test #7	B-17
APPENDIX C - TYPICAL CYCLE.....	C-3



Accession For	
NTIS GRA&I	<input checked="" type="checkbox"/>
DTIC TAB	<input type="checkbox"/>
Unannounced	<input type="checkbox"/>
Justification	
By _____	
Distribution/	
Availability Codes	
Dist	Avail and/or Special
A-1	

LIST OF ILLUSTRATIONS

<u>Figure</u>		<u>Page</u>
1	Lighthouse Loads, Average and Peak.....	3
2	System Line Diagram - Power Side.....	8
3	Rectifier Output Voltage (ripple effect).....	10
4	Generator Re-strap (single to three phase).....	11
5	Lighthouse Test Suite.....	14
6	Battery Current Sample (charge cycle).....	16
7	PSM Flowchart.....	18
8	Charge Algorithm Flowchart.....	20
9	Cycle Plots.....	25
10	Life Cycle Logic.....	39
B-1	Failures to Sub-test #3.....	B-4
B-2	Sub-test #5, Discharge Hours.....	B-9
B-3	Sub-test #5, End of Charge Volts.....	B-11
B-4	Sub-test #6, Discharge Hours.....	B-15
B-5	Sub-test #6, Charge Hours.....	B-16
B-6	Sub-test #7, Discharge Hours.....	B-18
B-7	Equalize Charge, Typical.....	B-19
C-1	Typical Cycle Information.....	C-4
C-2	Typical Cycle Information.....	C-5

LIST OF TABLES

<u>Table</u>		<u>Page</u>
I	Typical System Voltages	12
II	Cycles (Cause of Failures)	26
III	Engine Duty Cycle	27
IV	Charge/Discharge Times	28
V	Fuel Consumption.....	28
VI	Generator Power.....	29
VII	Battery Efficiency.....	30
VIII	System Efficiency.....	30

ACKNOWLEDGMENTS

I would like to thank and credit LCDR T. J. Barrett who was project manager for this effort until his reassignment to the U.S. Coast Guard Academy staff in June of 1988. His managerial and engineering skills were instrumental to the success of the prototype power plant.

INTRODUCTION

PURPOSE. This interim report describes the progress made in developing and testing a new power system for use at remote lighthouses. The new power plant will replace continuously running diesel generator sets if adopted for use. The new system's purpose is to reduce life cycle operating costs, particularly those pertaining to periodic maintenance. The prototype development is an element of the "Major Aids to Navigation (ATON) Systems Management" project at the Coast Guard's Research and Development Center (R&DC), Groton, Connecticut (ref. 1).

BACKGROUND. The Coast Guard operates over 400 major aids to navigation. Within this group are remotely sited lighthouses and floating marks where commercial power is either unavailable or too costly to install. It is estimated that 40% of the money budgeted for major ATON operation goes to running just 45 remote sites. A major expense incurred annually at these remote lighthouses is the transportation of personnel for maintenance and repairs.¹

Coast Guard planners desire a more maintenance free system. Recent engineering efforts have focused on reducing load power requirements through more efficient optics. These low power lighthouses can make use of photovoltaic panels as a sole power source (ref. 3). However, complete solarization of aids with loading above 1 kilowatt (kW) is generally not cost effective

¹ The cost figures for remote sites are referenced from the project's master plan (ref. 2). Justification for these dollar breakouts come from an informal survey of diesel powered lighthouses called forth by Commandant Notice 16500, Sept. 1986. The survey was conducted by the Ocean Engineering Branch (G-ECV-3), Civil Engineering Division, Coast Guard Headquarters. Its purpose was to categorize failure modes at remote lighthouses.

when compared to diesel-electric systems. Most remote landfall lights use more than 1 kW (Figure 1). In addition, stand-alone solar systems may not be practical at some sites because of the area needed to mount sufficient numbers of panels. Of the 45 remote sites, at least 33 still remain dependent on diesel power (ref. 4). The Coast Guard is continuing efforts to develop a reliable hybrid power system to address these lights.

OBJECTIVES

The Coast Guard desires a remote lighthouse that is fully automatic, 99% reliable, and requires routine maintenance only once a year. The current generator sets are run continuously and need routine engine maintenance 4 times a year (ref. 5). This maintenance interval can only be changed by reducing the total annual engine hours. Fundamentally, this means shutting the engine off.

The concept of charging a battery while running a load and then shutting the engine off while the load depletes the battery is called cycle charging. This concept is feasible at remote lighthouses because present generators are run lightly loaded part of the time. They see peak power only when all the signals are on simultaneously. Extra power is available when the gensets are running because signals are either set to off by external conditions or are not synchronous with each other.

This extra power is utilized by the new system to charge a battery. It allows the engine to be periodically shut off when the battery is fully charged. The goal of the cycle charge prototype (CCP) is to minimize engine run time while optimizing generator efficiency. One objective is to apply these economies in a manner that will lengthen routine maintenance intervals so expensive deployments can be scheduled less frequently.

A second objective is to provide an environment where load power

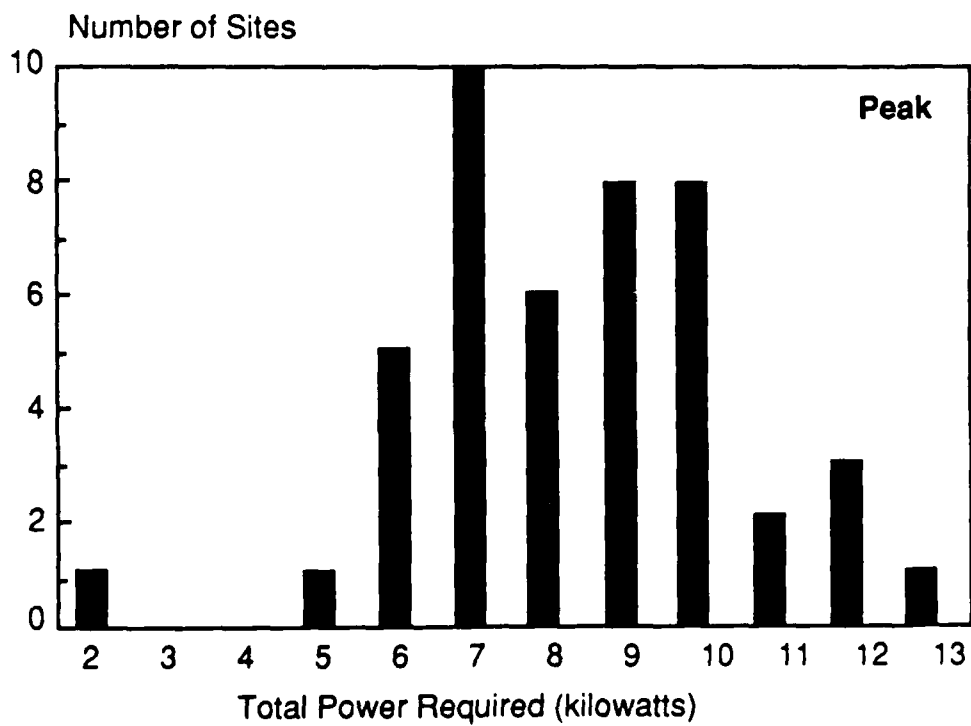
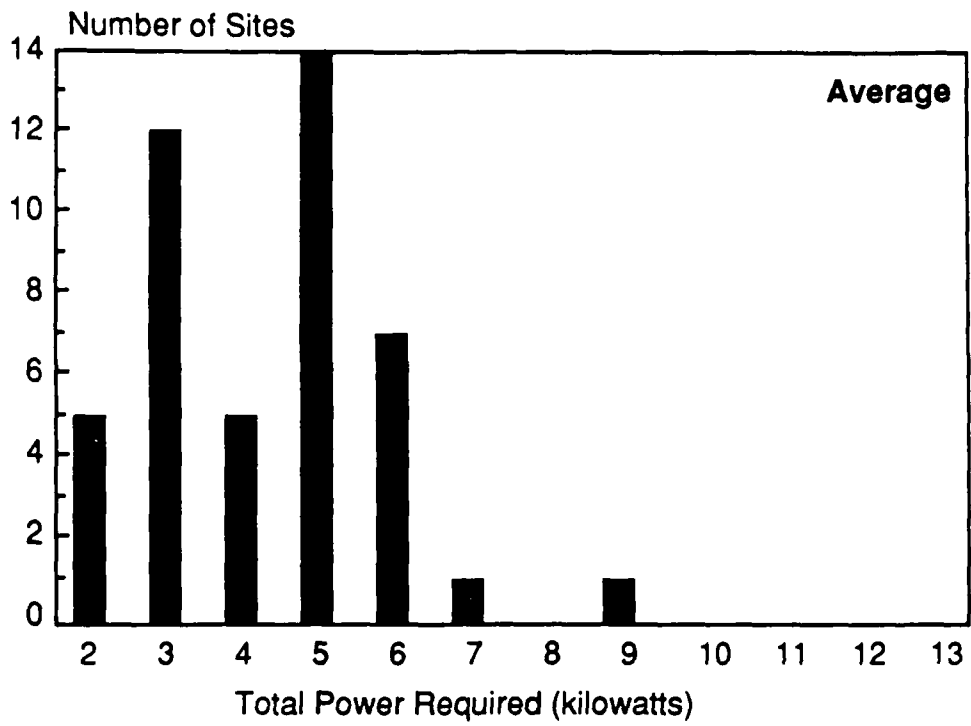

Figure 1. Lighthouse Loads, Average & Peak

reduction can be pursued. Currently there is no incentive to use newer low power signals or innovative signal management techniques because they will only worsen the already poor engine efficiency. Battery power removes this objection, and presents the opportunity to greatly reduce engine hours through load power reductions.

DESIGN

GUIDELINES. Recommendations from an earlier effort were used as guidelines in designing the cycle charge prototype (ref. 6). The following suggestions were developed:

- (1) employ direct current (dc) bus to power dedicated inverters supplying individual lighthouse loads;
- (2) use a battery capable of automatic electrolyte management as a "flywheel" storage device;
- (3) develop a microprocessor based current controller for battery charging; and,
- (4) program an algorithm for that controller using feedback from the battery to determine instantaneous charge acceptance.

TEST PLAN. No formal test plan was adopted. The project called for the system to be designed, constructed, and operated for at least six months. Engineering analyses and operating experience were to be reported post test. The effort was directed as a proof of concept.

CONSTRAINTS. The CCP was not designed from scratch. The first design constraint was to use existing lighthouse equipment as a system core (ref. 7). Lighthouse Automation and Modernization Program (LAMP) systems typically employ LISTER/LIMA generator sets. The CCP utilizes a model SR3, that provides 10 kW (12.5 kilovolt amps (kVA), 120 volts alternating current (VAC), single phase, at 0.8 power factor).

Generator size is a critical parameter for designers of cycle charge power systems. It helps determine engine running time by

how much power is available for charging and how the charge is applied. The charge regime in turn impacts on battery selection and sizing. The generator size also determines fuel efficiency by what percent of its capacity is being utilized. Diesel gensets perform best when they operate near 80% of their rated capacity.

The LISTER/LIMA SR3 was not a limiting design factor in the CCP because the charge algorithm and load used did not require power outside of the generator's range.

A second constraint was that the battery storage system would physically fit within the space now occupied by one of two diesel gensets found in a standard power volume. LAMP equipment is typically housed in a 16 x 10 foot (.) fiberglass ANDREWS structure (formerly called GRASSIS hut). These buildings provide a weather proof and environmentally controlled space for power equipment. The volume for a battery in this structure would be approximately a 5 ft. cube. The capacity of electrochemical storage devices depend on electrode surface area. The available volume could restrict the total battery power desired.

The HAGEN battery used in the CCP was not affected by the space available, because its dimensions are roughly 5 x 3 x 2 feet.

More general considerations should also be formally recognized. The lighthouse system as a whole was not considered. Only the power plant was redesigned. Analysis regarding load reduction or signal management were not addressed. For purposes of the design, lighthouse loads were considered to be from present inventory and operate with "on" characteristic continuous. This meant that any results derived would represent the "worst case" to be expected from a field application.

The last design constraint was that the system should require only one site visit per year for routine maintenance.

To summarize, the following were pre-design conditions:

- (1) the generator used in the CCP would be a current one found at remote Coast Guard lighthouses;
- (2) the battery selected would integrate into the present power volume hut;
- (3) the delivered power would be compatible with existing signal equipment, 120 (VAC), single phase, 60 hertz (Hz) nominal (nom.) format; and,
- (4) the developed system would require one maintenance visit per year.

The cycle charge prototype was built accordingly. For the prototype these constraints were not limiting. However, these factors should be recognized as problem areas for optimizing future systems.

The CCP also presented the opportunity for comparison to earlier Coast Guard experiences with hybrid systems (ref. 6). A viewpoint was adopted that saw the CCP as an evolutionary process starting with mastering cycle charging and eventually growing to a hybrid system with modular alternative energy inputs. The percent of alternative energy deployed would be site dependent rather than system dependent because the heart of the design is the direct current (dc) power bus and most alternative devices (i.e., photovoltaics) are dc sources.

COMMERCIAL ALTERNATIVES. No formal survey was conducted concerning the availability of a commercial system. Several companies offer remote power systems as a product line and some of these companies were contacted during the CCP development for advice. Most systems they install operate in the 24 to 48 volt dc range and power communications equipment requiring less than 1 kW. No companies suggested experience at 120 volt dc levels and the 5-10 kW ranges the Coast Guard needs. No companies claimed to have the sophistication we desired with respect to microprocessor based battery charging. Several expressed an interest in providing turn key lighthouse systems.

COMPONENTS DESCRIPTION. Figure 2 shows a line diagram of the CCP. Descriptions of the major components are listed in Appendix A.

MAJOR NEW COMPONENTS SELECTION. The reasons for selecting the major new components of the CCP follows.

Battery. The HAGEN was selected to test a multi-celled battery capable of deep depths of discharge (DoD). It was designed for use in powering city busses in Germany and was advertised as having the capability for a large number of deep discharge cycles. The HAGEN is a flooded lead-acid battery which is considered an inexpensive battery technology. In addition the HAGEN has equipment for electrolyte management. The hardware includes an air bubbling electrolyte destratification pump, a closed loop electrolyte heater, a single point watering system for electrolyte make-up, and counting meters for ampere-hours (Ah) in and out of the battery. The HAGEN was acknowledged as being "small" in ampere-hour capacity (175 Ah) for use with alternative energy devices, but this phase of development was primarily focused on cycle charging. This limitation was further justified by the HAGEN's packaging and electrolyte management system potential. Testing with small capacity would allow for an accelerated accumulation of cycles aiding verification of the manufacturer's life-cycle claims. In terms of the charge algorithm's current requirements the battery was accurately matched to the generator set. Finally, the HAGEN was recommended by a consultant who reviewed the Cape Henry design (ref. 8).

Rectifier. Three-phase full-wave bridge rectifiers are commonly used in high power dc applications (ref. 9). The component selected is composed of six semiconductors mounted on heat sinks and interconnected with bus bars. It is manufactured by INTERNATIONAL RECTIFIER (IR) and is preferred by the BASLER voltage regulation company for conversions of the LIMA generators from ac to dc. The voltage produced by these types of rectifiers

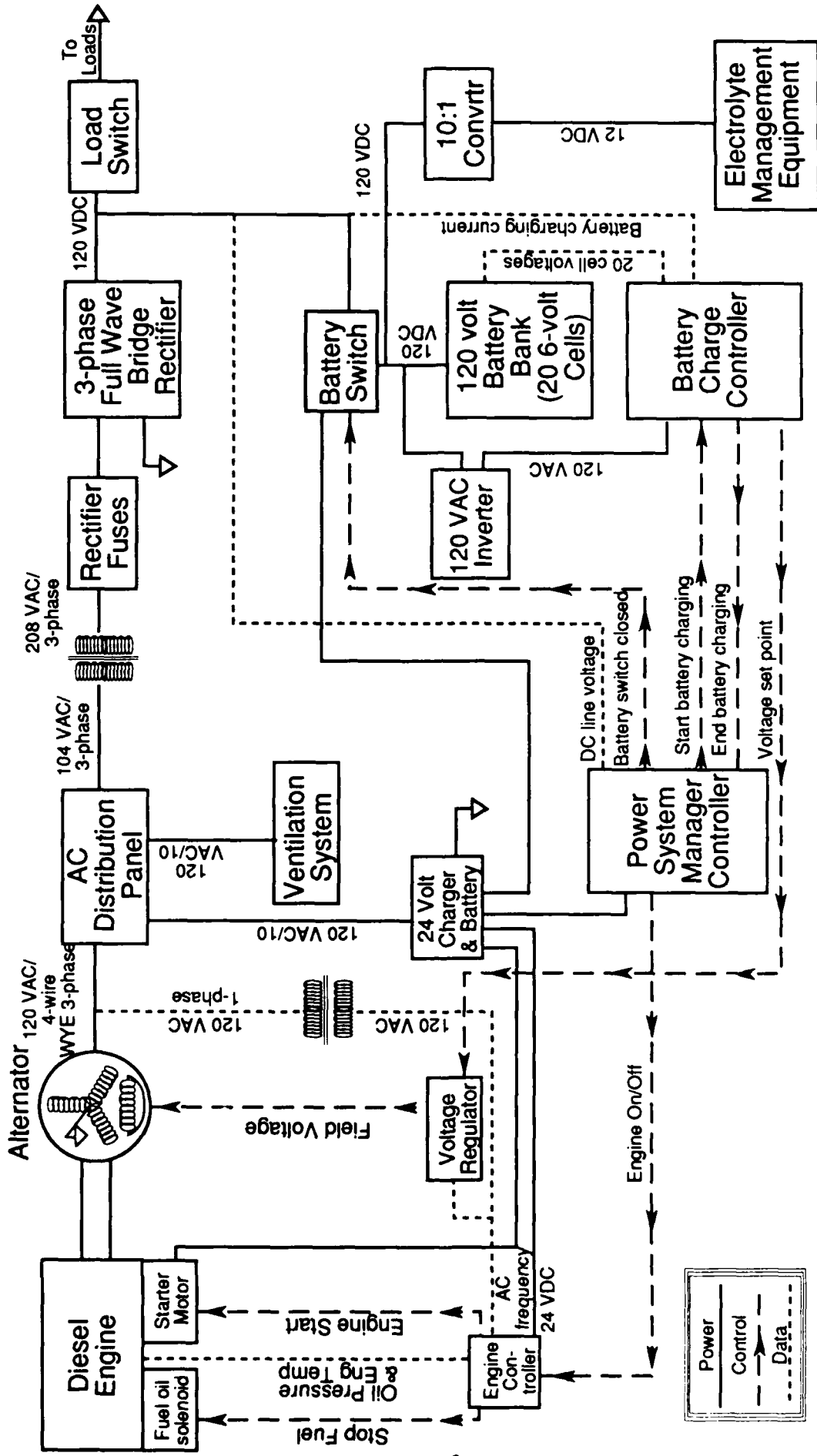

Figure 2. System Line Diagram — Power Side

typically show a four percent ripple imposed on the load voltage at a frequency of 360 Hz. Figure 3 shows a voltage sample taken on a NICOLET oscilloscope from the rectifier's output. Filtering of this ripple to reduce its magnitude is normally required for battery charging. None was used in the CCP because our samples showed the ripple effect to be less than four percent. It should also be noted that the 12 pole LIMA generator was re-strapped from single phase operation to three phase. The new configuration is shown in Figure 4. The rectifier was protected on the feed side with a 70 ampere (A) quick blow fuse for each leg.

Power Transformers. The output VDC of a three phase bridge rectifier is always less than the input VAC. An ideal full wave bridge transformer is governed by the following relationships (ref. 9):

$$\text{VDC} = 0.740 * \text{VAC (rms, leg to leg), and}$$

$$\text{VDC} = 0.428 * \text{VAC (rms, leg to neutral)}$$

In order to provide proper control of charge voltages it was first necessary to define the system's voltage limits. The minimum system voltage was desired to be 114 VDC which approximated 60% capacity of a fully charged HAGEN. The maximum system voltage had to be 150 VDC. This was the high voltage disconnect value designed into the main load inverter. In practical terms the system required voltage control between 100 and 150 VDC, the charge range being 114-136 VDC. The ability to regulate under 114 VDC insured the diesel generator would never start under load.

Early field experiments showed it would not be possible to adjust the voltage regulator's range and meet the 100-150 VDC criterion with good control because the required VAC range would be approximately 165-250, open circuit. To provide the desired system voltages it was necessary to lower the voltage regulator's range setting and artificially boost the SR3's output voltage.

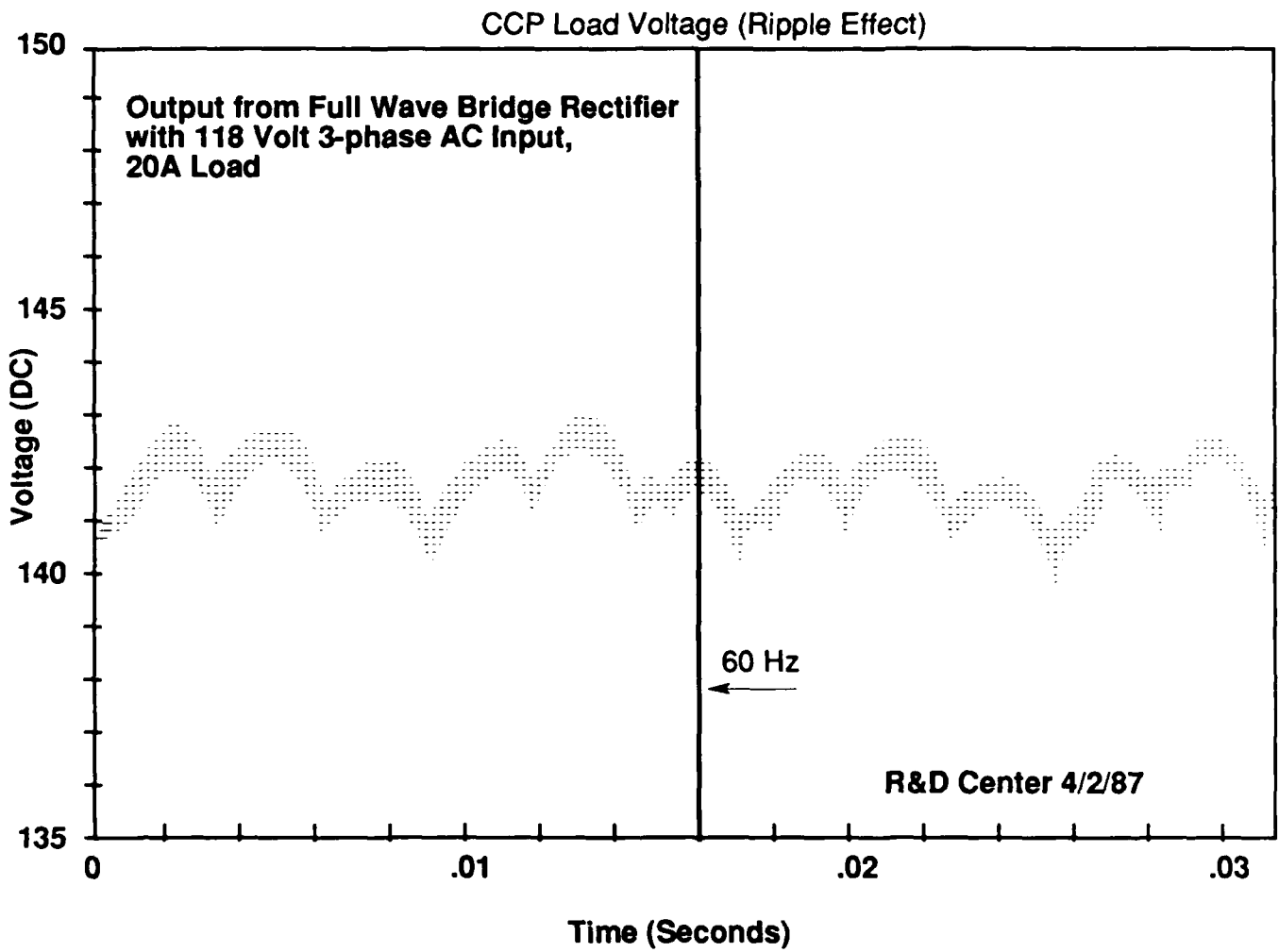

Figure 3. Rectifier Output Voltage

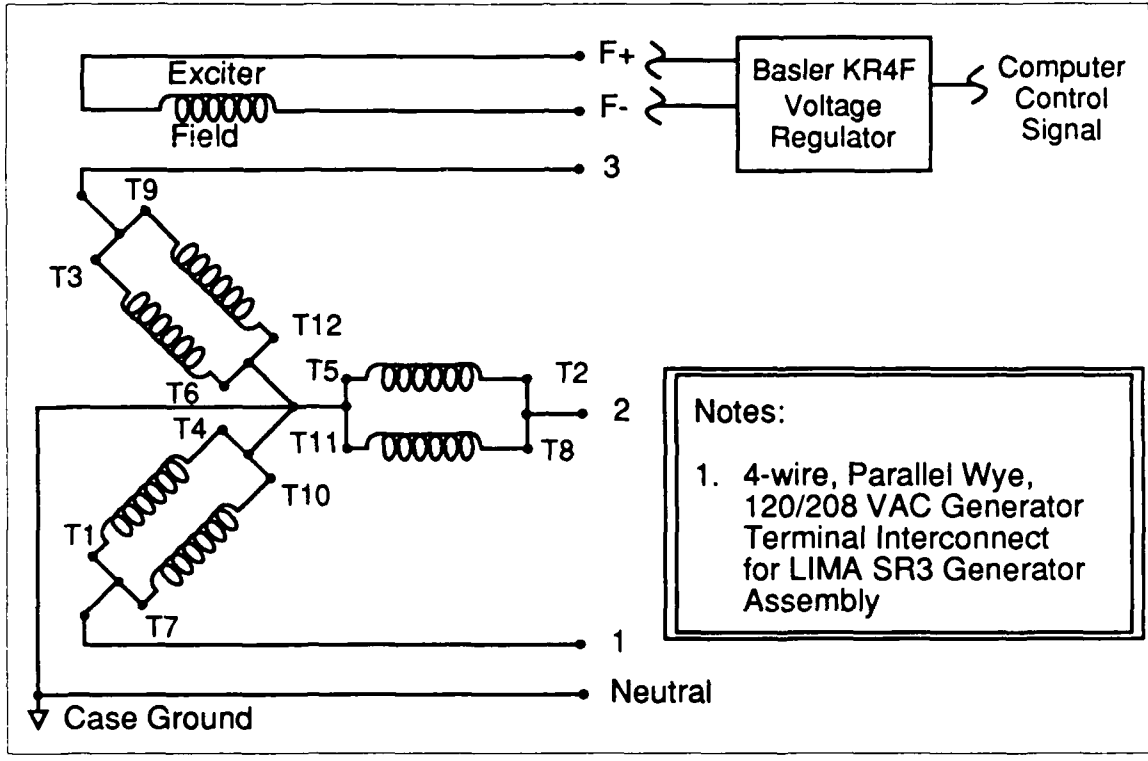

Figure 4. Generator Re-strap

This was accomplished with GENERAL ELECTRIC 2:1 power transformers. Three individual transformers were purchased as a matter of convenience. Each served a phase of the generator output. The 5 kVA rating was expected to service a maximum phase output of 3 kVA at 0.8 power factor. Table I lists some actual voltage relationships that occurred during testing.

An engineering decision was made not to retap the generator for a higher voltage configuration (240 VAC) because several housekeeping loads ran on 120 VAC and conditioning downward with transformers would be necessary to satisfy those needs. A more detailed examination of operational requirements is covered in the operations section of the Design chapter.

TABLE I
TYPICAL SYSTEM VOLTAGES

VAC_{sec} (gen)	VAC_{pri} (rect _{in})	VDC_{ld} (rect _{out})	V/R_{adj} (vdc)	ALG_{sig} (vdc)
127	254	152	0.00	0.00
122	244	146	0.18	0.90
118	236	142	0.22	1.10
111	222	133	0.48	2.40
107	213	125	0.61	3.05
98	196	117	0.82	4.10
66	132	79	2.00	10.00

Inverters. Two load inverters were purchased for the system. They are manufactured by SOLEQ Corporation of Chicago, Illinois. Both were selected because of their reputation in the railroad industry and because they use solid state circuitry in place of SCR devices. The SCR based inverter used in an earlier system caused numerous problems (ref. 6). The main load inverter which supplied the Nav-Aid controller was a 3 kW unit. The inverter for the radio beacon was a 0.5 kW device. A third 0.5 kW unit powered the charge controller (HEWLETT PACKARD, 120 VAC 60 Hz input) off of the HAGEN battery, but was not part of the load suite. The SOLEQ inverters produce a pure sine wave signal as opposed to a modified square wave output. Inverters suffer efficiency losses operating below rated capacity. The design rationale for multiple inverters is to maximize unit efficiency and prevent total load loss in failed, single inverter, series type construction.

Load Suite. A simulated lighthouse was constructed for purposes of testing the CCP. The 3 kW average (4 kW peak) load used represented a "small" lighthouse within the present remote lighthouse population (ref. 11, Figure 1). It consisted of an AUTOMATIC POWER CG-1000 fog signal power supply with matched resistive dummy loads (1000 watts), a CARLISLE-FINCH DCB 224 rotating beacon with 2-1000 watt lamps, and a 500 watt NAUTEL NX-1000-BD radio beacon with a resistive dummy load (Figure 5). A 12 volt NiCad battery and SAB-NIFE battery charger were also installed to simulate the emergency power supply found at lighthouses.

OPERATION. The CCP operates automatically. Three controllers share responsibility for operations: the power system's manager (PSM); the charge controller; and the engine controller. During normal operation, the PSM controller repeats a software loop monitoring system conditions during the discharge period. When the HAGEN's terminal voltage drops to 114 (1.90 volts per cell (VPC)) two analog signals are sent out. One signal is sensed by

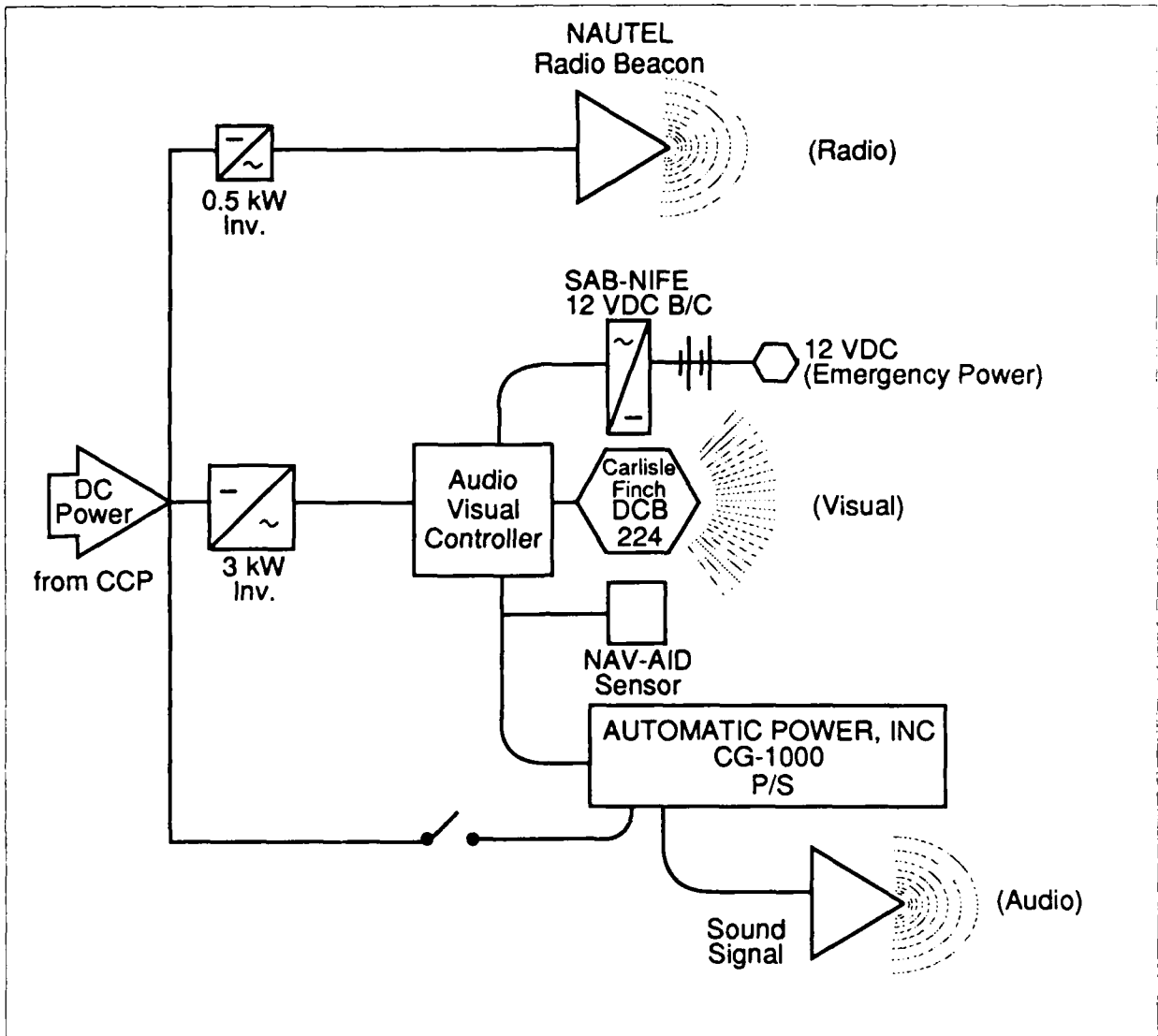
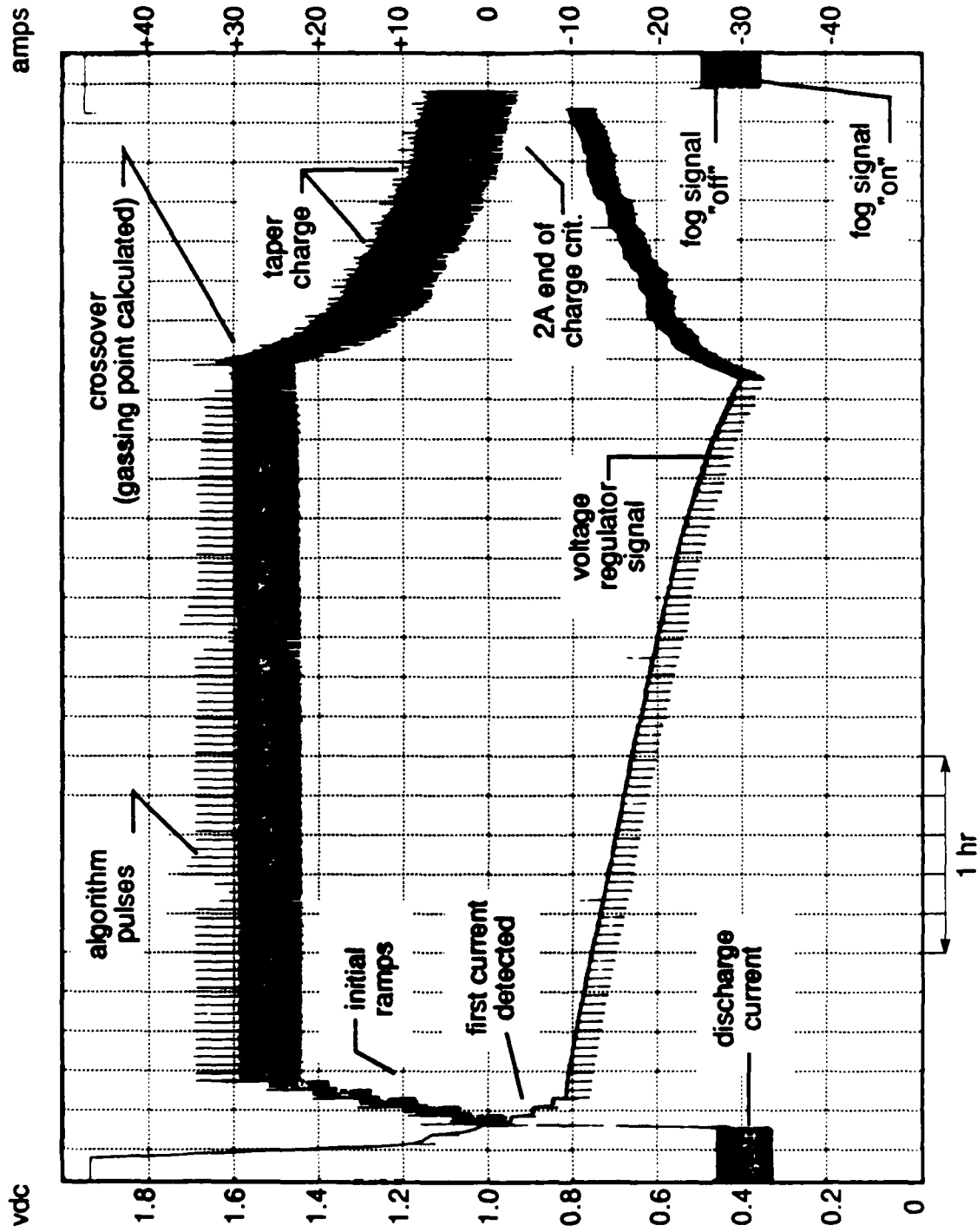

Figure 5. Lighthouse Test Suite

the engine controller which begins the programming sequence to start the diesel. The other is sensed by the charge controller and initiates the charging algorithm. During charging, the bus voltage (-charging current-) is manipulated by applying an analog signal from the charge controller to the voltage regulator's voltage level adjustment terminals. The magnitude of the signal sent is determined by software response to measured battery conditions. The battery is monitored for cell voltages periodically, the maximum rate being once every 10 seconds. Charging rates are then calculated by the algorithm. Figure 6 shows a typical current sample in and out of the battery plotted over time. The current has ranges because the sound signal and charging algorithm cause current spikes according to their respective duty cycles. When a full state of charge is determined a signal is returned to the PSM. The PSM sends an "engine off" flag to the diesel engine controller which completes the cycle. The battery is then discharged by the load suite at a rate of approximately 30 A, root mean square (rms) value. A typical CCP cycle lasted about eight hours. Actual cycling experience is discussed in the results section of this report.

PSM. The system controller was developed at the R&D Center. The brain board is a model #886 purchased from OCTAGON. The 886 has an RS-232C serial port, an 8 channel analog to digital (A/D) port, and 16 channels of direct digital input and output (I/O). It supports 64,000 bytes of erasable programmable read only memory (EPROM) with auto-run capabilities. The bus architecture is STD. The card was selected for its ease of use (resident compiled BASIC) and because Coast Guard Headquarters expressed a desire that future controllers be STD capable. The on board processor is a V20 (enhanced 8088, INTEL) operating at a clock speed of 5.12 megahertz (MHz). The field to logic interfaces were made through optical isolators manufactured by OPTO-22. Analog inputs were scaled through resistive divider networks.



Time (5 increments = one hour)

Figure 6. Battery Current Sample

A software loop looks at two values, the dc bus voltage and the return signal from the charge controller indicating a charge is complete. Three decision processes are made on the dc bus value. First the voltage is compared to 114. If the condition is less than 114 the program diverts to the start charge subroutines. Two other decisions are made for high (150) and low (110) conditions that might occur from genset failures. Figure 7 is a flowchart of the PSM's operating logic.

The other signal monitored by the loop is the end of charge flag relayed from the charge controller. When this signal becomes high (10 VDC) the PSM routes to the stop charge routines, shutting off the engine by sending a signal to the engine controller.

The PSM was intentionally left simple so the initial efforts could focus on macro problems of the system. Loop execution with a print statement for bus voltage monitoring took less than one second. More software for electrolyte control systems was programmed but never utilized because of mechanical failures in those subsystems. The original plans called for regulation by program control of electrolyte temperature and volume.

CHARGE CONTROLLER. The charge controller was developed under a contract with the Johnson Research Center, University of Alabama, Huntsville (UAH) (ref. 10). The goal of UAH research was to develop a charging method that would be independent of the battery's age, state of charge, or operating temperature. The charge controller consisted of a HEWLETT-PACKARD (HP) 85 computer running an HP 3852 Data Acquisition and Control unit.

Recent research has shown that during the operational life of a multi-celled battery the terminal voltage characteristics of individual cells will begin to vary due to the quality of construction, self discharge, and treatment (ref. 12). This

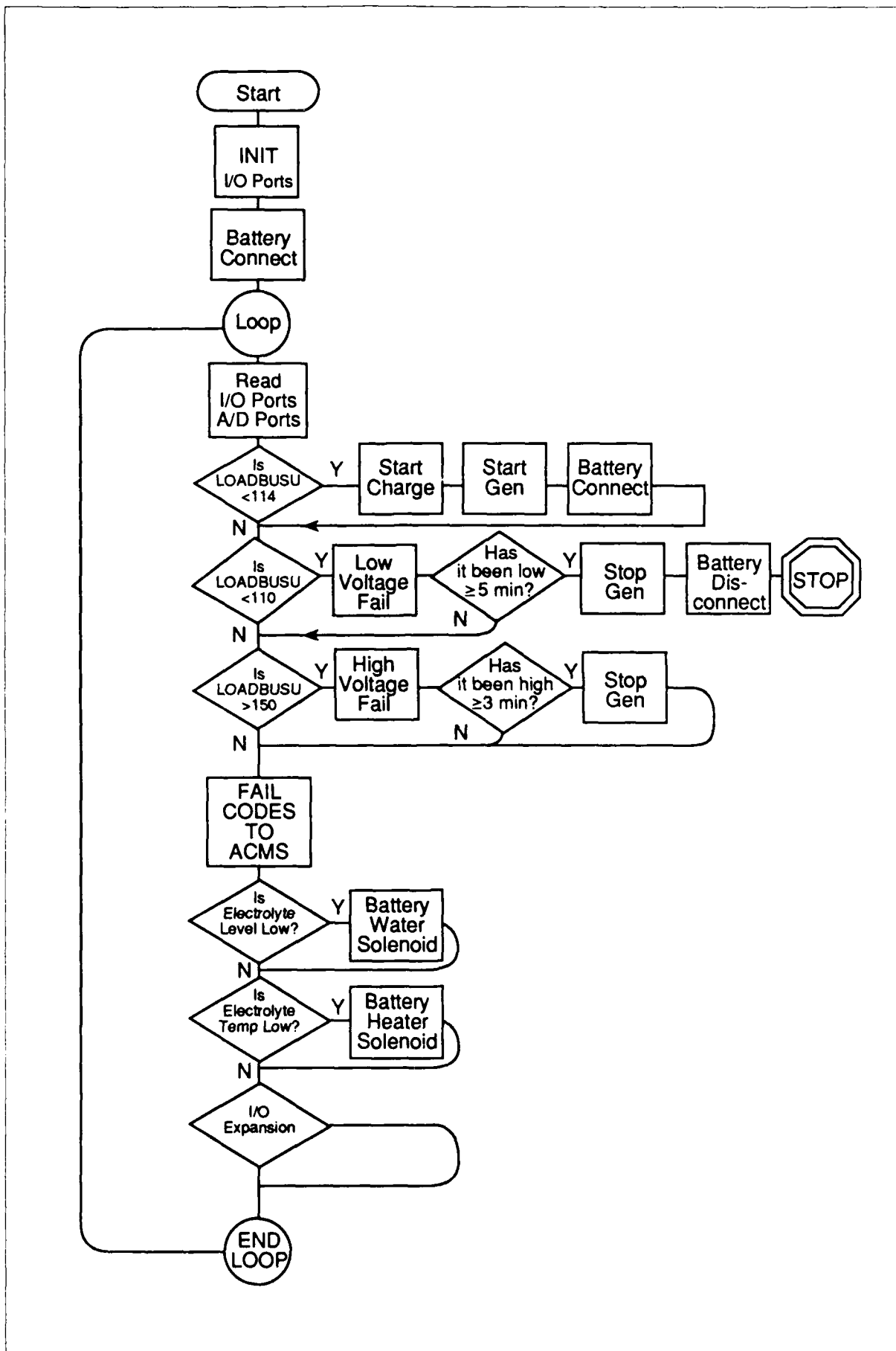

Figure 7. PSM Flowchart

variance eventually leads to gross over or under charging. Conventional battery chargers that depend on the battery's overall terminal voltage for input cannot discriminate cell imbalances. These conditions can reduce the life of the battery and lead to system inefficiency. Cell mismatches can be expected to occur after 200 cycles (ref. 12). The algorithm used in the charge controller is revolutionary because it attempts to charge in a manner that optimizes charge acceptance independent of the battery's age or operating temperature. To accomplish this it correlates charge rates to individual cell voltages by calculating internal cell resistance via Ohm's law. The lowest voltaged cell is used as a reference for comparison of the "charge" state and the "pulse" state. The calculated resistance correlates to heat buildup in the cell.

Algorithm Specifics. The software observes a "wait" command after receiving the start charge signal from the PSM controller. The voltage regulator's setting for this "wait" is two volts. This is the maximum programmable value and leaves the generator with a diminished field and the engine idling. The rectified generator voltage is lower than the battery at this starting point and no charging current flows. This allows the diesel engine time to start and stabilize. This short period was acceptable without stressing the engine because the algorithm progresses with the charge in gentle steps of 5 A.

When the "wait" is completed the software enters a start charge (Figure 8) routine to increase the dc bus voltage to a point where positive current can be measured flowing into the battery. The adjustments are made via computer controlled analog signals to the voltage regulator in 5% increments of the total adjustment range. The current measurement is made through a shunt in series with the battery and is measured as a millivolt (mV) signal.

When the first positive current is detected the software enters

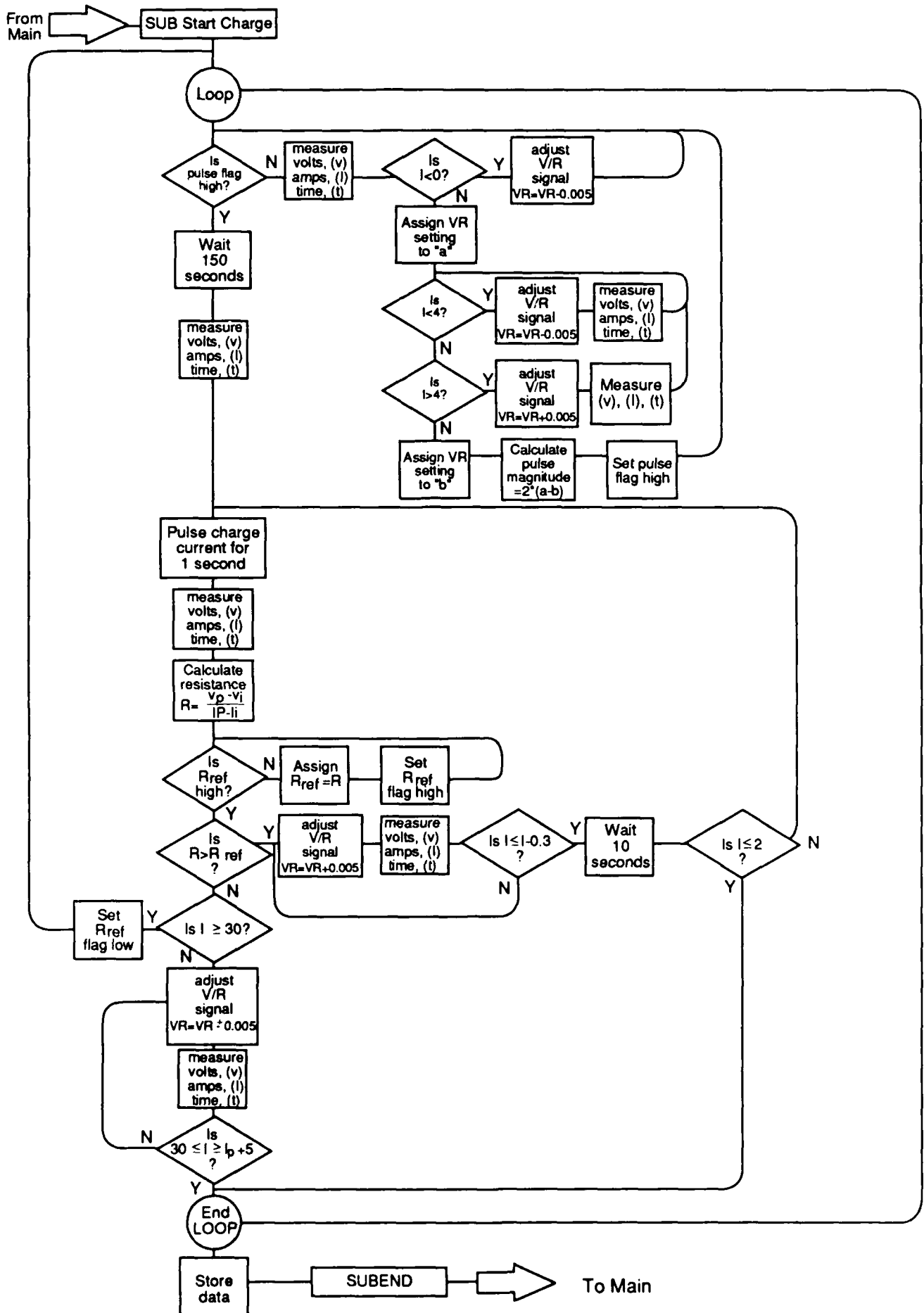

Figure 8. Charge Algorithm Flowchart

another routine to adjust this first current to exactly 4 A. The HAGEN battery is then charged at 4 A for 2.5 minutes to allow any potential gas to develop. In a discharged battery none would be measurable at this point.

A significant value is determined in these early routines. The difference between the setting for the first detectable current and the setting to achieve 4 A, times 2, equals the size of current pulses applied through the remainder of the charge. It is desired that these power pulses be near 10 A in magnitude. The pulses are used to determine internal cell resistances which are correlated by the algorithm to charge acceptance.

The 20, 6-volt modules that make up the HAGEN are measured next for voltage through a multiplexing analog to digital (A/D) card. The values are recorded in memory and the module with the highest voltage is selected as a reference module. The reasoning behind this is that it would be the most likely candidate of the 20 to reach a gassing state first (ref. 10). A resistance value for this reference module is calculated using Ohm's law, dividing the bus voltage by the current measurement.

The current pulse (approximately 10 A) is then applied to the bus by adjusting the signal to the voltage regulator from the "pulse" routine. Within a period of one second of applying this pulse, the reference module is once again measured for terminal voltage and charging current and a new "pulsed" resistance is calculated. If the pulsed resistance value is greater than or equal to twice the initial reference resistance then the software diverts to a tapering routine. In normal operation this does not occur and the battery charging current is raised 5 A for 2.5 minutes more. The previous routines are repeated again, and if the pulsed value is less than twice the reference value the bus current is turned up five more amps and charged for 2.5 minutes more.

This stepping routine is continued until a maximum charge rate of 30 A is achieved or tapering begins. Figure 6 shows the current pulses occurring at the 2.5 minute intervals at the start of charging. The periodic variation of the current is caused by the sound signal load and its duty cycle. When 30 A is achieved a new reference resistance is calculated for comparison purposes. It replaces the value determined at the 4 A base level.

While the 30 A charge continues, the 20 modules are measured once per minute and sorted for the one with the highest voltage measurement. If necessary, a new module is used for comparison to the reference value in order to prevent over-gassing of any modules.

When a module's pulsed resistance value is finally found to be equal to or greater than twice the reference value, the crossover point has been reached, and the algorithm enters the taper charging routines. Each time the measured resistance is greater than the reference, the charging current is lowered in steps of 0.3 A. During this phase of charging the frequency of pulsing is shortened from 150 sec. to 10. Figure 6 shows this taper period having a distinct negative slope and a darkened band caused by the chart recorder's pen responding to the increased sampling.

The battery is determined to be fully charged if the selected control module measures greater than 7.5 VDC or the charging current measures less than 2 A. At this point the "end of charge" signal is sent to the PSM controller and the charge controller's software goes back into a loop where it waits for another signal from the PSM, indicating another charge should be started.

The resistance values calculated for the pulsed states were compared to cell resistances measured under forced overvoltage conditions in a laboratory for differing states of charge. The

curves generated by these data sets matched closely and supported a mathematical model which described a relationship between charge acceptance and internal resistance. That relationship could be expressed as a function of voltage and current, determining internal cell resistances by Ohm's law. This led to the algorithm's development and provided relief from the need for expensive gas flow meters to indicate increasing state of charge (ref. 10).

The power provided by a battery charger can be viewed as having several components. The basic parts are: power for charge reaction, power used up by electrolysis, and power lost in heat generation. As a battery becomes charged its impedance increases. This complicated process is analogous to the idea of the PbSO_4 being further and further consumed during the charge and the remaining Pb ions still needing to react, having an increasingly difficult time finding partners for reaction.

This apparent resistance is normally observed as heat. It can also be measured as a resistance. As a battery's state of charge increases, the balance of the charge power changes in favor of the gassing and heat components. To gain proper control over the charge power, continuous monitoring of the cells and adjustment of charge current is necessary. This allows some individual cell control over heat buildups and limits power lost to gassing. The algorithm attempts to provide this degree of control which should result in optimum charging rates with extended battery life (ref. 10).

ENGINE CONTROLLER. The engine controller was developed at Coast Guard Headquarters under a separate effort. It is also STD compatible. The microprocessor's software starts and stops the engine and monitors shaft speed, oil pressure, and block temperature.

RESULTS

PERFORMANCE BACKGROUND. The "operational" testing was performed between 1 April and 1 November 1988. Four hundred and fifty-four (454) cycles were completed, the longest consecutive run lasting for 150 cycles (58 days).

It is difficult to categorize results because the system did not operate continuously for the entire time. It is appropriate to focus on those portions of the test where continuous automatic cycling was achieved to gain insights into what economies of operation may be expected from a system of this type.

Figure 9 plots cycles completed over time. Seven sub-tests are plotted on this graphic with the corresponding number of cycles achieved. The seven events are singled out because they are representative of the successes and failures experienced while developing the system. Two general failure modes occurred,

- (1) controller software failures, and
- (2) degradation of battery capacity.

Both of these conditions were correctable. Appendix B explains in detail the failure modes and remedial action taken for all seven sub-tests. Each failure was followed by a troubleshooting and servicing interval where additional cycling was performed. These days are included in the plot, but only consecutive unattended cycles were considered significant for data analysis.

RELIABILITY. The nature of cycle charging leads to an expectation of routine repeatability. Likewise, the nature of prototype development is based on troubleshooting and correcting problems. Both conditions occurred throughout the test period. At times the system ran perfectly, and on other occasions "fixable" failures occurred. These conflicts make it impractical to calculate system availability or reliability. The system was

regarded as mechanically sound midway through the test period. The reason for this assumption is based on sub-tests 6 and 7, which had 62 and 150 consecutive cycles, respectively. Both sub-tests were aborted manually.

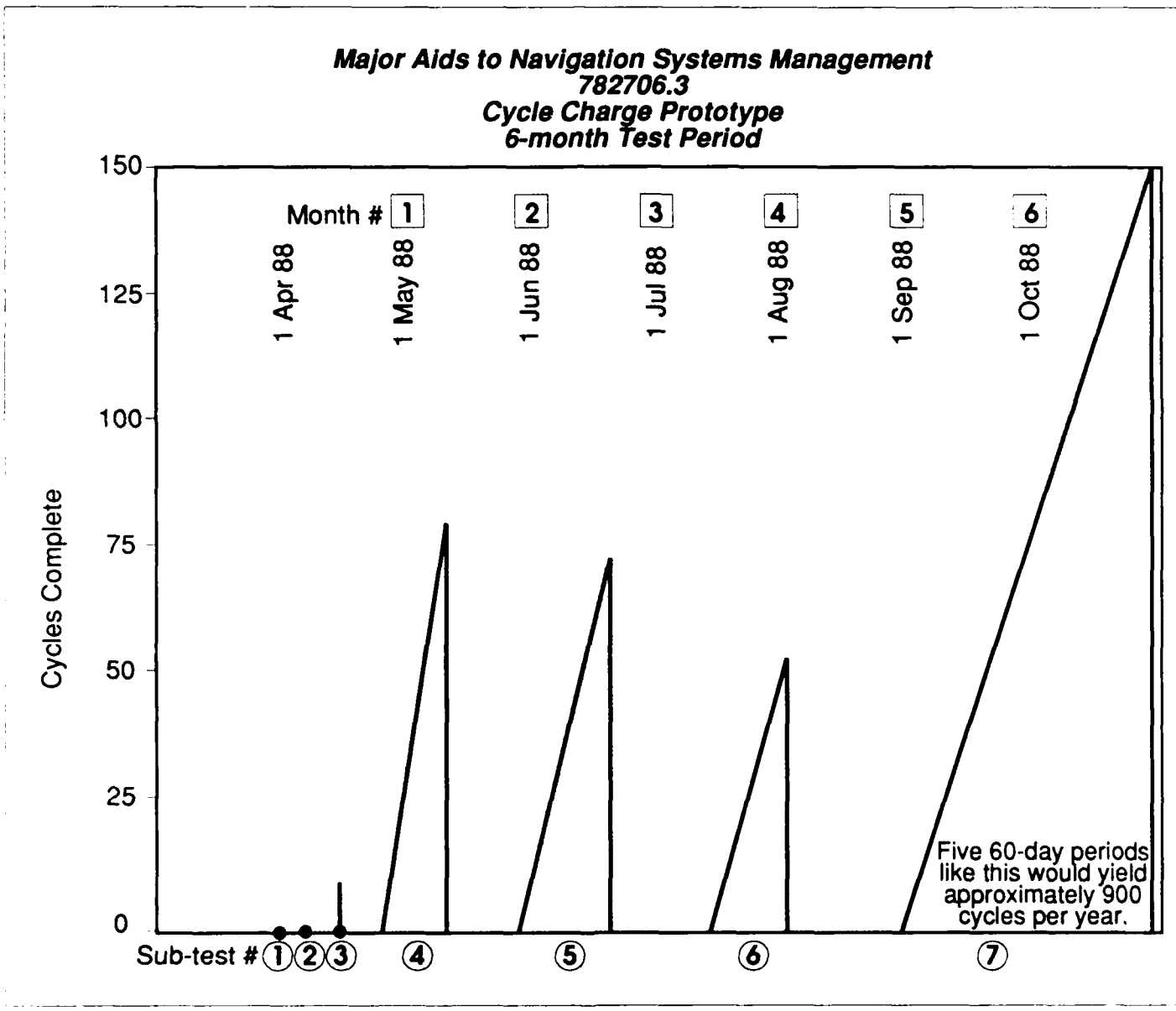

Figure 9. Cycle Plots

CYCLES. Eighty-three (83) troubleshooting cycles were completed between the seven sub-tests. When added to 371 cycles done during sub-tests, the entire test period accumulated 454 cycles. Prior to the April 1 start of testing, approximately 100 cycles were completed. Additional cycles performed in Huntsville, AL, during development of the algorithm were approximated at 50. Six hundred (600) cycles are used as the total life cycles achieved by November 1, 1988. No accurate records of discharge depths were maintained. Sixty percent (60%) DoD is an estimated average. The battery did develop cell imbalances, but still met the definition of "healthy" because it was able to deliver 80% or greater of its initial capacity at the C/6 rate. Table II details significant facts of the seven sub-tests.

TABLE II
CAUSE OF FAILURES

Sub-test #	Dates	# of Cycles Completed	Reason for Termination
1	4/1-4/2	1	failure of system controller software
2	4/7-4/8	1	"
3	4/16-4/17	6	engine controller; no start in 3-attempts
4	4/26-5/11	77	engine controller; underspeed caused by algorithm spike
5	5/28-6/21	74	manually off; loss of HAGEN capacity
6	7/15-8/2	62	"
7	8/30-11/1	150	successful sub-test/ manually off; end of test period
	TOTAL	371	

ENGINE DUTY CYCLE. The engine was "on" 62.11% of the time during sub-tests 4-7. The engine is "on" 100% of the time in the current LAMP systems. Table III shows individual sub-test values. Sub-test 7 probably demonstrates values closer to what a properly running system would provide (60.58%) because the prototype had become much more reliable and the cycle profiles were not distorted by "freak" or unusually long taper charges. The only exception to this was the addition of the cell equalizing routine added in sub-test 7 and described in Appendix B.

TABLE III
ENGINE DUTY CYCLE

Test	Cycles	% Engine "on" Time
sub-test #4	77	66.89
sub-test #5	74	62.55
sub-test #6	62	58.43
sub-test #7	150	60.58

CHARGE/DISCHARGE TIMES. The average charge period lasted 4.78 hours. The average discharge period lasted 3.09 hours. The average cycle time was 7.87 hours. Table IV lists statistical data from the sub-tests.

FUEL USAGE. Table V lists fuel consumption statistics. The "real time" average was 0.37 gal./system hr. On a yearly basis this would equate to 3,241 gallons. An SR3 operating at an average 50% load capacity (typical LAMP) uses about 0.50 gal./hr. (ref. 13). This is equivalent to 4,380 gallons per year.

TABLE IV
CHARGE/DISCHARGE TIMES

ITEM	Sub-test #			
	4	5	6	7
Cycles (total)	77	74	62	150
Mean Charge (hrs.)	5.02	4.87	4.32	4.91
Mean Discharge (hrs.)	2.68	2.89	2.94	3.87
Median charge (hrs.)	N/A	5.02	4.83	5.59*
Median discharge (hrs.)	N/A	3.44	3.57	3.80
Maximum charge (hrs.)	N/A	11.30	8.82	10.89*
Maximum discharge (hrs.)	N/A	4.33	4.22	4.80
Minimum charge (hrs.)	N/A	0.17	0.10	3.22
Minimum discharge (hrs.)	N/A	.83	0.08	3.20

* Includes routine for equalize charges after every 10 cycles.

TABLE V
FUEL CONSUMPTION

Item	Sub-test #			
	4	5	6	7
Actual (gal./eng. hr.)	0.61	0.59	0.56	0.58
Real time (gal./sys. hr.)	0.41	0.37	0.33	0.35

GENERATOR POWER. Table VI lists generator facts. The generator averaged 6.04 kW over the charge periods. While charging at the peak current rates and fully loaded with all signals on the generator operated near 9 kW.

TABLE VI
GENERATOR POWER kW

ITEM	Sub-test #			
	4	5	6	7
AVERAGE (total kWh generated/eng. hrs.)	5.91	5.93	6.26	6.08
PEAK (measured)	8.99	9.13	8.91	9.44

BATTERY EFFICIENCY. Table VII lists battery efficiency as an energy measurement and a coulomb measurement. The energy measure is an external indicator of how the battery can handle power on a systems basis. A coulomb measure indicates the relative health of the battery plates and their ability to achieve stoichiometric performance. The HAGEN had an energy efficiency average of 85.46%.

SYSTEM EFFICIENCY. The average system efficiency was 85.07%. This value was determined by dividing the energy consumed by the load suite by all energy produced with the generator set, including system losses and parasitic household loads. Table VIII lists the values from sub-tests 4-7.

TABLE VII
BATTERY EFFICIENCY, %

ITEM	Sub-test #			
	4	5	6	7
ENERGY (kWh out/kWh in)	82.49	87.53	89.68	88.37*
COULOMB (Ah out/Ah in)	N/A	N/A	96.60	N/A

* Equalize charges can impact on these efficiencies because the recharge factors are higher.

TABLE VIII
(System Efficiency, %)

ITEM	Sub-test #			
	4	5	6	7
ENERGY (kWh load/ kWh generated)	80.42	84.92	87.75	87.19

CONCLUSIONS

The following conclusions can be drawn from developing and operating the cycle charged power system. They are valid only for the described system.

- (1) The CCP demonstrated a design capable of reducing annual engine hours by approximately 40% when compared to the continuously running LAMP systems. The engine generator set will operate more efficiently than it does in LAMP and use about 25% less fuel annually.
- (2) The CCP demonstrated the successful use of microprocessor based controllers to provide improvements in battery charging control methods.
- (3) The charge algorithm under test in the CCP required a significant change before achieving quality cycling. The algorithm will require further testing and refinement before it is useful for field applications.

DISCUSSION

PROBLEM AREAS. Three technical areas need to be addressed further in the CCP design. They are:

- (1) electrolyte maintenance,
- (2) software revisions, and
- (3) general safety factors.

ELECTROLYTE MAINTENANCE. The HAGEN battery comes equipped with a single point watering system. The parts are designed to allow automatic and continuous regulation of the electrolyte volume through an arrangement of pressurized pipe headers supplying float valves submerged in each cell. The piping system is connected to a static head reservoir containing deionized water. The recommended pressure is 5 psi for positive float closure. When the system was initially tested upon receipt from the development lab at UAH it was discovered to be non-functional. Several of the floats had dislodged from their guideposts and had fallen into the electrolyte that covers the tops of the plates in

each cell. They could not be recovered and reinstalled. The subsystem was effectively useless. Project plans had called for this to be the battery watering device. No alternatives were considered because of time and personnel constraints.

The HAGEN was watered manually during the test period. The battery water need averaged approximately 0.567 ml/cell/cycle. Making an extrapolation of 1000 cycles per year the system would require 30-40 liters of deionized water per annum. A reliable mechanical system that can provide this service must be engineered because the reservoir of electrolyte above the cell plates in the HAGEN is not large enough to operate for a year without replenishment.

The impact of the malfunctioning watering system cannot be de-emphasized. Without this subsystem working, the entire concept of reduced systems maintenance is voided because watering would become a manual task. Several alternatives exist to remedy the situation. One alternative is to specify a more durable watering system for the HAGEN. This is valid, but still dependent on moving parts. A better approach may be to design a passive subsystem. Several techniques have been suggested where cells could be interconnected at their bases and share a common supply source controlled only by atmospheric pressure. Another option is to use catalytic recombination caps. The final design could follow any of these suggestions or a mix of them.

The other electrolyte subsystems worked without failure. A 12 VDC air compressor supplied a continuous stream of pressurized and filtered air to each cell through a piped distribution system. No measurements pertaining to the degree of stratification in each cell could be made because the plates and separators were too densely packed to allow readings anywhere except at the top of each cell. Active bubbling could be observed when the compressor was operating. The system's purpose is to cause the electrolyte's concentration to become more

uniform when measured along the cell's vertical profile and to restrict internal heat build-up.

The thermostatically controlled electrolyte heater also worked without failure. It consisted of a pump circulating propylene glycol solution through a closed loop piping arrangement embedded in the cells. After passing through the cells, the heat transfer solution returned to an accumulator that added heat through electric resistance. The HAGEN powered all the 12 volt accessories through a dc/dc converter.

No special tests were performed on this subsystem to verify the degree of control obtainable. General field observations showed the heater could raise the temperature of the electrolyte on gross levels. Because the battery generates heat during charging and this heat is transferred from the battery core only to the ambient room air, changes in electrolyte temperature are slow to effect. During the major portion of the test period the heater was set to "off" because the interior of the power volume was 80-90 degrees F, which was very close to the electrolyte temperature. The hut conditions were a result of the summertime ambient temperatures and from residual heat produced by the diesel engine. Any computer control of the electrolyte temperature would need sophisticated software to compensate for the slow reaction time to temperature adjustments. Overheating might occur otherwise and damage the battery. The electrolyte temperature, ambient temperature, and hut temperature were monitored during the test. On average the electrolyte temperature would be 10-15 degrees F higher than the interior power volume temperature. Its ranges during cycling were less than +/- 5 degrees F. The best way to control electrolyte temperatures is to limit charge currents, monitor heat build-up in the electrolyte, and condition ambient temperatures within the power volume. No cold weather operations were conducted.

SOFTWARE REVISIONS. The software used in the various controllers was eventually refined to an acceptable state for the proof of concept test. However, before a system of this type could be field deployable, further revisions would be necessary. Programming improvements should focus on making the software more comprehensive. More decision making logic should be employed to double and triple check any process that calls for a field action. This would insure that erroneous signals would not be executed and protect the system from certain types of circumstantial failures. It may also be desirable to store historical information that is pertinent to the operation at hand. In general the software needs to be more sophisticated (smarter). The final software product should process system information and make decisions that ensure the highest degree of signal delivery. These additions will be inevitable if future systems contain alternative energy devices. Power will need to be managed to make effective use of what is available at any particular moment. For example, a charging sequence powered by the diesel during peak daylight hours would most likely elevate the bus voltage above the solar array output and effectively diminish their ability to produce power. Calendar, time of day, and external conditions are just examples of the sophistication needed to make good use of alternative power sources when deploying a microprocessor controller.

FUTURE FACTORS. Battery charging in a closed environment such as the power hut will require special attention to the exhausting of hydrogen gas produced during charging. When the CCP was operating in a charging mode, a ventilation fan cut into the upper portions of a wall adjacent to the HAGEN would come on. This was the only design change made to the standard power volume room conditioning equipment used in LAMP systems. No measurements were done to find the air exchange rates existing in the building or the amount of gas generated by the battery during charges. The exhaust fan was powered by the generator set because it was assumed the only time gassing could occur was during a charge

cycle and the diesel would necessarily be on. Make up air for the diesel engine and ventilation fan is provided through a 4-inch opening in an end wall. In future systems it may be safer to have redundant gas ventilation subsystems powered by the battery. The reasons for this are threefold: (1) some gas continues to be produced in the period right after charging ends, 2) if a fan motor failed, explosive hydrogen gas could accumulate in the building over successive charges and (3) alternate energy devices would not help ventilate the hut interior as the generator's fan does because their power is not alternating.

Other safety issues concern high voltage dc wiring practices and safe battery maintenance procedures. These would need to be engineered by a licensed professional and reviewed by an appropriate safety committee. The CCP was constructed and operated in a safe fashion, but was not reviewed by an accredited safety panel.

GENERAL. The CCP was successful as a "proof of concept." The design objectives of a dc bus, computerized current controller, and multiple load inverters were met. The area of electrolyte maintenance is the only reasonable objective which remains unsolved. The CCP design will never meet the one year maintenance requirement because it is theoretically impossible to achieve a 75% (6500 hrs./yr.) reduction in engine hours using the current generator as the sole energy supply for present loads.

The informal lighthouse survey mentioned in footnote #1 stated that visits to some remote sites were required as often as 15 times a year. Visits are categorized as scheduled or unscheduled. The reasons for making unscheduled maintenance trips are not always related to the power delivery system. Optical and control systems account for many of the discrepancies.

Any argument for a new lighthouse power system must be tempered with the reality that power delivery is only a subsystem of a total lighthouse design. The findings of this report can only address the visits made for routine servicing and refueling. The application of these findings will not make a significant reduction in deployments to sites that have a high discrepancy rate from non-power system failures.

BATTERY COSTS. Cost analysis or other types of economic evaluations were not performed on the CCP because they would be premature prior to establishing system reliability. However, it is practical to offer rough estimates gained from developing the system because such numbers can quickly illustrate any potential for savings.

Large stationary batteries will cost \$75-\$100 per Ahr installed. This figure reflects all parts necessary to make up an installed CCP system. The lower estimate reflects standard flooded lead acid batteries while the upper limit is indicative of nickel-cadmium or iron-nickel couples. Barring negligence or excessive DoDs, all battery types will last more than one year. How long any battery will last is a complex issue and is addressed in the next section. With the charge rates and DoDs used in this system, one might expect the battery to last 5 years. A practical battery for the Coast Guard will likely be less than 1000 Ahr in capacity because size and weight constraints will make installations too expensive or difficult. The capital costs of a CCP system deploying a 500 Ahr battery would be estimated at \$50,000. This figure does not include potential costs associated with future battery disposal. According to the figures available in footnote #1, four visits for diesel maintenance work can cost \$26,000 per year.

OTHER BENEFITS. The creation of the dc bus and the elimination of a conventional battery charger will enhance system savings

further. Two factors support this claim:

- (1) dc busses will allow the addition of alternate power sources as desired; and,
- (2) "smart" battery chargers will lengthen battery life.

These factors may appear subtle, but they are important keys to larger savings. If the lighthouse load is powered by alternate energy sources, then the targeted engine hours can be reduced more, theoretically to zero. The dc bus gives the designer the freedom to chose the most practical alternate sources for his site. The determining factor would appear to be the comparison between the capital cost of the alternate sources and the unit cost of an engine maintenance deployment.

If the extra alternate energy is designed for the voltage ranges that define the discharge period, then the cycles will be lengthened in time and the overall accumulation of cycles slowed. This will increase the battery life (usually defined in cycles, see Figure 10b) and impact dramatically on life cycle costs. It would also eliminate the complications of regulating alternate sources into the charging portion of a cycle.

Another future benefit is the use of computers to control charge current. This subsystem is independent of the battery type that could be selected in a CCP design. The ability to control charge current continuously will guarantee longer battery life because gassing and heat generation can effectively be controlled through better monitoring (Figure 10d).

BATTERY SELECTION. The heart of any new system will be centered on the battery storage system. Several factors enter into the decision making process for selecting a battery. Most of these do not compliment the requirements of an ideal cycle charge power system. Figure 10 describes typical relationships between depth of discharge and battery life. When a battery is repeatedly deep

discharged, the mechanical and electrochemical processes cause decreased life expectancy (Figure 10a). How the energy is replaced in the battery is also critical. High charge rates decrease charge time but increase electrolyte maintenance (Figure 10c). Low charge rates increase engine hours but decrease maintenance.

Other conflicts exist. Batteries under consideration for use in the CCP can be categorized by electrolyte form, flooded or immobilized. In general, flooded batteries can accept high initial charge rates which result in low annual engine hours but require electrolyte maintenance. The amount of maintenance depends on how the battery is charged. Immobilized electrolyte batteries are often packaged as sealed or "maintenance free" batteries. When charging sealed batteries, care must be taken not to gas and over-pressurize the container causing failure. This requires the battery be charged at relatively lower rates and for longer times, which increases annual engine hours.

Battery capacity is also a factor. A large capacity (Ah) battery matches well with the high lighthouse loads because even at discharge rates of 50 A or more an extended discharge will leave the battery at a relatively shallow depth of discharge. Shallow depths of discharge lengthen battery life in cycling applications. In most alternative energy applications it is necessary to have a large capacity battery so that low energy input periods can be tolerated and still provide load power. However, battery costs and physical size usually increase with capacity. This may prohibit construction at some sites.

The HAGEN battery (175 Ah), using 1000 cycles per year, should last 3-5 years at the 60% DoD that was used. Other battery technologies may be able to improve on these figures. For alternate energy applications the HAGEN should be considered too small in capacity.

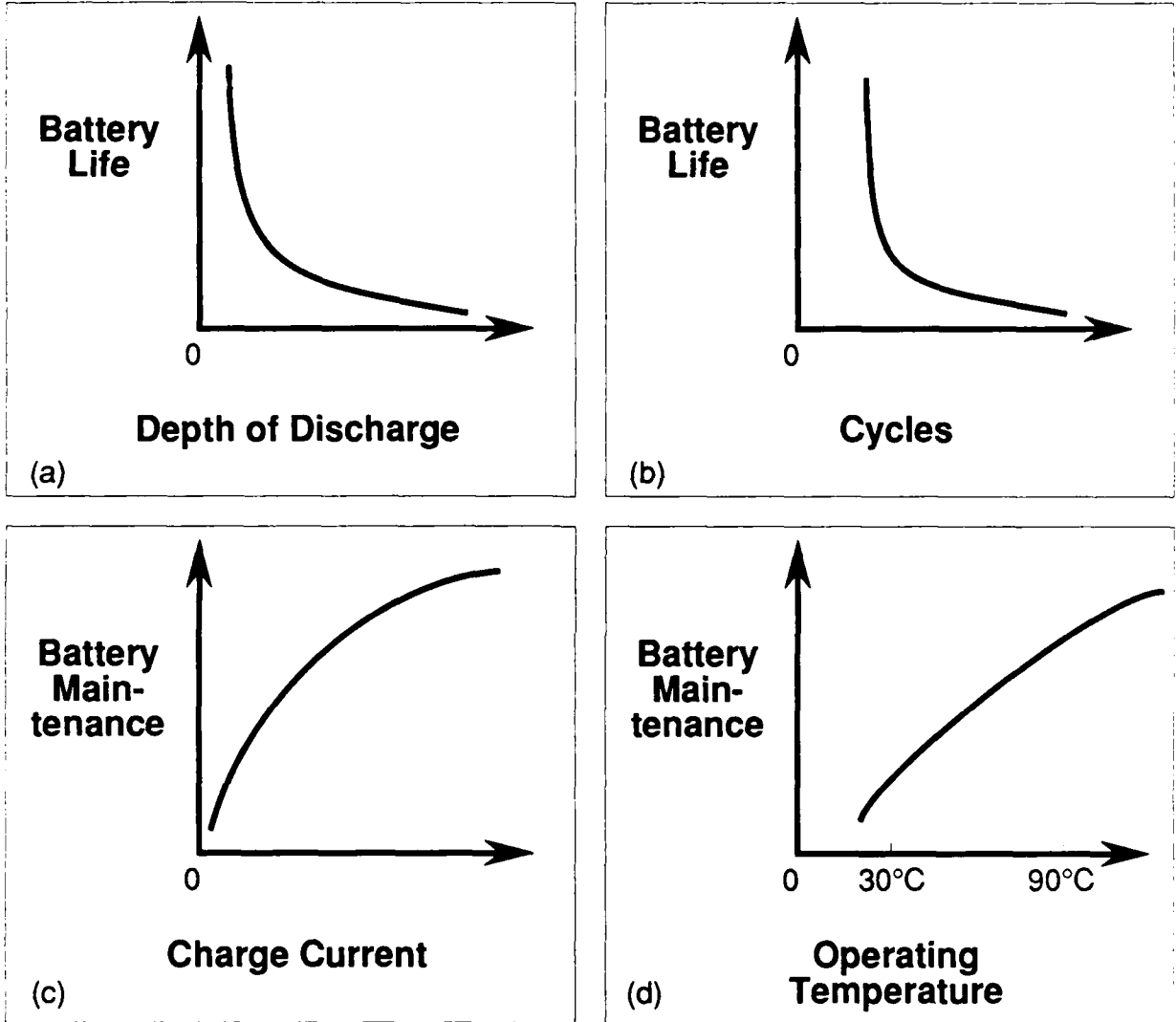

Figure 10. Life Cycle Logic

RECOMMENDATIONS

- (1) Investigate the potential to reduce engine hours beyond the 60/40 split demonstrated by the CCP. Use solar, wind, and other alternate sources as parallel energy inputs to the dc bus. For simplicity, it is recommended that these sources be sized for load powering, not battery charging.
- (2) Install a larger capacity battery. As a rule of thumb the minimum size should be at least ten times the load current in Ahrs. Battery type, cell geometry, vent cap design, and charge rates should emphasize the longest possible water servicing interval that can be achieved. Pursue charge algorithms that maximize engine efficiency and prolong battery life but minimize electrolyte maintenance.
- (3) Enhance software to assure signal delivery is the highest priority of the system.
- (4) Determine CCP reliability and initiate a cost analysis of the CCP versus standard lighthouse power delivery systems using the most current data available.
- (5) Document all findings in a format useful for contract or district engineers.

REFERENCES

1. G-E memo, 16500, dated 31 Jan 1986, to G-D, via G-N, Request for R&D Support-Telecomm RD&C/ECV-3 (Harley Cleveland).
2. Major ATON Sytems Management, Master Project Plan, PMP #782706, 1989, USCG R&DC, Physical Sciences & Technology Division, Physics Branch, Project Officer Lt. M. Fisher.
3. Telecomm R&DC (Lt. M. Fisher) /G-ECV-3 (Mr. H. Cleveland), 01/89.
4. IALA Annual Report, United States Coast Guard, 1988; Chief, Short Range Aids to Navigation Division; #16504, 01/24/89.
5. Lighthouse Preventative Maintenance System; COMDINST M16500.10; pg. 9-D(1).
6. Analysis of a Stand Alone Power System for Remote Site Applications; by J.R. Thacker; Report # CG-D-28-86; May 1986; pg. 5-1.
7. Alternate Hybrid Power Sources for Remote Site Applications; by Powell et al; Report # CG-D-06-81; Feb. 1981; pg. 3.
8. Analysis of the Cape Henry Lighthouse Hybrid Energy System; by Dieter Novak; 1986.
9. Reference Data for Radio Engineers; by Howard W. Sams & Co., ITT Subsidiary; 1975; Sixth edition; LCCCN: 75-28960.
10. The Development of a Charge Algorithm for the Optimized Charging of a 120 V Flooded Lead-Acid Lighthouse Battery with Forced Electrolyte Destratification; by Dieter Novak; Johnson Research Center, University of Alabama in Huntsville; March 1988; developed under contract MIPR Z51100-6-00002.
11. Light List; DOT-USCG; Vols. 1-7; U.S. Government Printing Office, Washington D.C.; 1989; COMTPUB P-16502.
12. Impact of Mismatched Cell Characteristics on Lead-Acid Battery Charging; by W. H. Deluca, A. F. Tumnillo, R. L. Biwer, and N. P. Yao; Argonne National Laboratory, Argonne, Ill.; Report # 830228.
13. Technical Handbook, Lister Diesels; by Technical Publications Department of R.A. Lister & Co. Ltd.; Edition 1; 1985; GL11 4HS, Gloustershire, England; Division of Hawker Siddeley.

14. Instruction Manual for KR4F Regulator; Basler Electric, Highland, Illinois; #911600099X; Rev. A: October, 1985.
15. Storage Batteries; by George Vinal; John Wiley & Sons, New York; 4th Edition, 1954; Library of Congress Catalog Card # 54-12826.
16. Rapid Charging of Lead-Acid Batteries for Electric-Vehicle Propulsion and Solar Electric Storage; by Paul Longrigg; Solar Energy Research Institute; June 1981; SERI/RR-742-1068.

APPENDIX A

[BLANK]

APPENDIX A (cont'd)

CYCLE CHARGE PROTOTYPE COMPONENTS

<u>Item</u>	<u>Description</u>
<u>diesel generator set</u>	Standard High Endurance Engine/Generator Set; serial #33; engine #25SR3A29; 18 hp; 3-cylinder; 1800 rpm; LIMA generator #A84608BD; 120 volt reconnectable; 104 A; 60 Hz; 10 kW;
<u>voltage regulator</u>	BASLER model KR4F; 60 volts field;
<u>main battery</u>	HAGEN BATTERIE AG; 72 cells, 60 used; model PzS 175; 175 Ah; 144 volts, 120 nom. used; 348 kg; serial # 3517672; 12/85;
<u>VAC distribution panel</u>	CROUSE HINDS LP112DS; 100 A main; 3 phase distribution; NEMA 1 type encls;
<u>power transformer</u>	GENERAL ELECTRIC; Type QMS; 5 kVA; 60 Hz; 1 Phase; Primary 240 volts; secondary 120 volts; temperature rise 115; Model # 9T21B100462;
<u>full wave bridge rectifier</u>	INTERNATIONAL RECTIFIER; model # CT150K3AA120;
<u>rectifier fusing</u>	TRON; model #KAB-70;
<u>auto. battery disconnect</u>	TELEMECANIQUE; model #P102E; 250 volts; 100 A; NEMA size 3; 24 V DC coil;
<u>manual battery disconnect</u>	CROUSE HINDS; General Duty manual Safety Switch; model #GU323; 240 volts; 100 A; NEMA Type 1 enclosure;
<u>charge controller inverter</u>	SOLEQ; model S11-112-0.5K-60; input, 108-155 VDC; output, 120 VAC, 60 Hz;

APPENDIX A (cont'd)

<u>Item</u>	<u>Description</u>
<u>charge controller</u>	HEWLETT PACKARD; HP-85, HP 3852;
<u>engine controller</u>	OCTAGON; SYS-11; OPTO-22; model PB-8 field/logic interface; w/ SPM27C64H EPROM;
<u>24 VDC battery</u>	MCGRAW EDISON; model HED-120; 20 cells; Nickel/Cadmium;
<u>system controller</u>	OCTAGON; model 886 Data Acquisition and Control Board; OPTO-22; model PB-24Q field/logic interface; w/ HN;
<u>main load inverter</u>	SOLEQ; model #SW1-112-3K-60-LS; 118-152 VDC input; 105-156 VAC output; 35 A rated drain;
<u>secondary load inverter</u>	SOLEQ; model S11-112-.5K-60; 108-155 VAC input; 120 VAC nom. 60 Hzs. output;

APPENDIX B

[BLANK]

APPENDIX B

SUB-TEST DETAILS

Analyses of failure modes. (see Figure 7. in report body)

Sub-test #1

The system had a dismal beginning when it failed to complete the first cycle on April 1. The system controller (PSM) failed sometime during the first charge period. The cause of the failure was traced to a coding error within an interrupt subroutine. The error fatally caused the processor to "lock up". The PSM could not respond by shutting off the diesel engine when the charge controller sent the signal indicating a full charge. More importantly the PSM could not perform its battery monitoring responsibilities. The HAGEN continued to be discharged by the lighthouse suite and passed through the critical 114 volt "start charge" level, ironically with the engine on and idling. Without communications between the two controllers no systems action could be completed. Finally the inverters tripped off line because of insufficient supply voltage. The battery came to rest at 96 volts. The system controller could not execute the battery protection disconnect set at 110 VDC because of its failed condition.

To remedy the situation the HAGEN was placed on a manually controlled equalize charge. The software was revised and a new EPROM chip with the coding updates installed. The repairs, recharging, and other incidental maintenance required six days. The system was restarted on April 7.

Sub-test #2

The system failed a second time on April 8. The symptoms of failure were identical to the first time. The cause of failure was a "crashed" system controller. The software changes made previously in sub-test 1 were not correct. The same methods described previously were used to bring the system back to an operating status. Special attention was given to recharging the HAGEN because of two consecutive discharges to its rated capacity. Some of the modules had individual voltages as low as 1.90 (vs 6.20). The system was restarted on April 15.

Sub-test #3

The system failed a third time on April 16 after running the load suite for 17 hours and 39 minutes. Six (6) cycles were completed but only the first ran as prescribed by the algorithm. Figure C-1 is a copy of a strip chart recording of the battery current and the voltage regulator's adjustment signal. The chart speed is 2 centimeters per hour. The first charge had a good "shape" as described by the charge current plotted versus time because

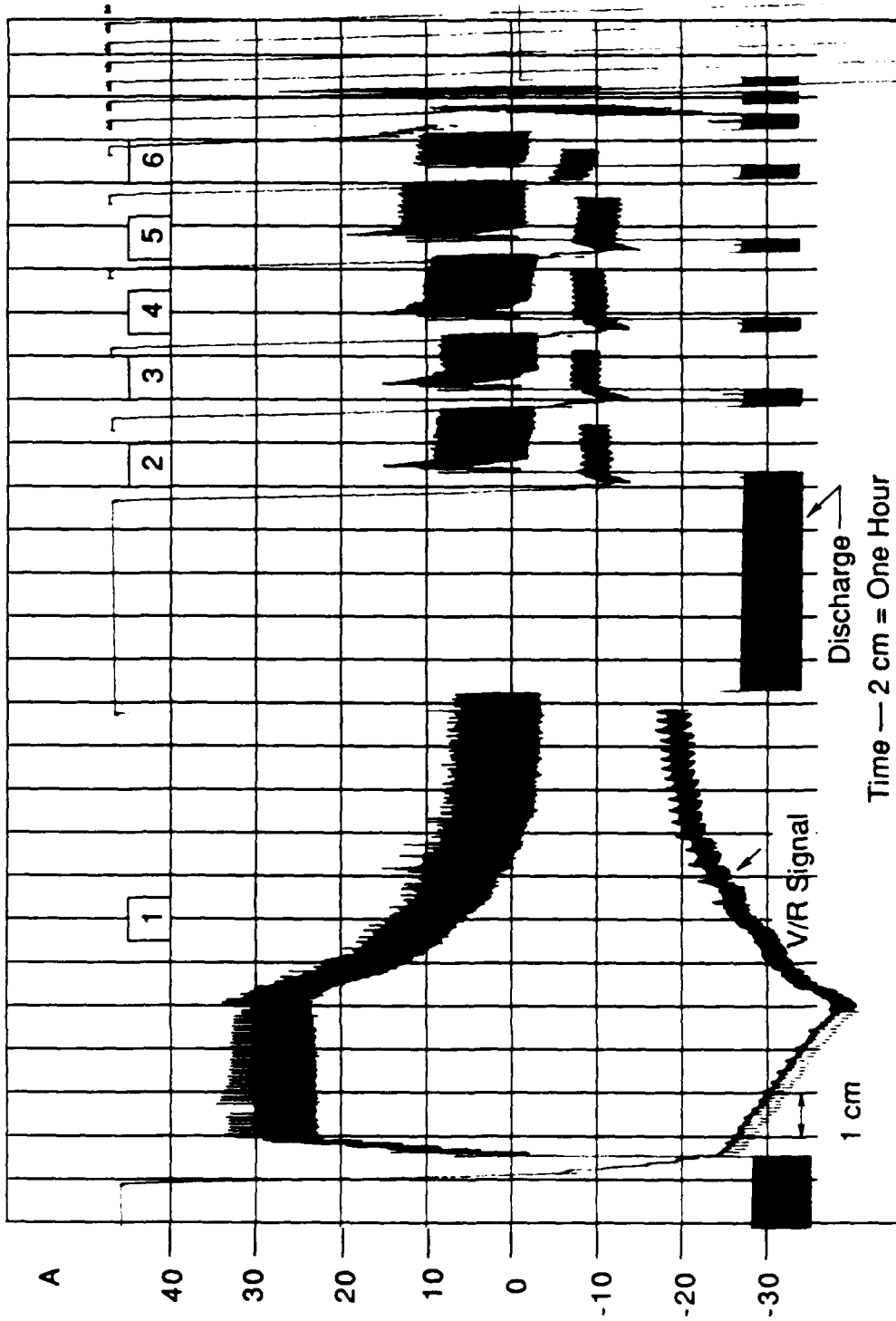

Figure B-1. Failures to Sub-test #3

the taper charge followed uniformly after the gassing was calculated by the algorithm. The PSM correctly started the recharging process after a 2.75 hour discharge. The next six charges showed an abnormal charge curve "shape".

The algorithm proceeded to charge the battery in the next six cycles as though the HAGEN were near full capacity. This was in agreement with maximum charge currents being less than 30 A. There was no obvious reason why this would happen. Common sense indicates the battery is not near a full state of charge after discharging at 30 A (rms) for 2.75 hours (47% of cap.). The only reasonable guess for these "short" cycles is a significant cell mismatch within the battery pack not evident during open circuit readings.

Most likely there was a module in the battery with a voltage significantly higher than others. It was selected by the algorithm as the one most likely to gas first and this resulted in limited charging currents, further under-charging the weaker cells. The cycles were shortened because either the charging rate was diminished to 2 A or this "strong" module surpassed 7.5 volts when scanned prior to pulsing. The fourth "short" charge clearly demonstrates this condition.

The system rapidly degraded. On what would have been the eighth cycle the engine shut off and could not be restarted within the required three tries. No explanation for the engine non-start was uncovered, although unusually large current swings can be seen in the eighth charge (Figure B-1). These may have overtaxed the fuel supply to the engine. A post test autopsy did in fact reveal dirty fuel filters.

Ultimately low battery voltage caused the system controller to disconnect the HAGEN from the system in order to protect it from extreme discharge states such as those experienced in the first two failures. According to software logic the system "properly" crashed. It should be noted the PSM did not include logic to run the diesel generator continuously in the event of a battery failure,-- so that failures in a field deployable system could be more easily identified. This would be a necessity, along with other statistical software improvements, to prevent emphasis being placed on the strongest imbalanced cells.

There was much concern after this failure that the HAGEN was destroyed by these accidental discharges and the long development period when it was subjected to extended idle periods and unusual charges. The battery was watered and placed on a low amperage charge in an attempt to equalize the cells. The voltages and specific gravity readings eventually returned to normal ranges. The next 10 days were dedicated to replacing components and revising software in data collection equipment. No fundamental design changes were done. On April 26 the system was restarted.

Sub-test #4

The system failed a fourth time on May 11 after completing 77 cycles. The system operated for 15 days, its first extended running period. It "properly" failed when the engine controller shut down the engine due to an underspeed condition. The underspeed was sensed when an unusually large pulse was called for by the charging algorithm. This pushed the generator to near capacity and the engine controller sensed the diesel engine "bogging" down as the engine's governor opened full throttle. To stop the engine the controller shuts off the fuel supply through a solenoid action.

The cause of the unusual current pulse is unknown. A review of the algorithm's software for pulse magnitude shows a variable "C1" is assigned to the voltage adjustment setting where the first positive current that is greater than 2 A can be measured going into the battery. Next a routine adjusts the charge current to exactly 4 A. The setting that accomplishes this is called "C2". The pulse magnitude for the duration of the charge is calculated to be $2*(C2-C1)$ (ref. e). The pulse width is one second. The voltage regulator's response time is less than 17 milliseconds (ref. 9). The pulse is applied as a voltage.

A review of all current pulses for the 77 cycles, collected by a strip chart recorder, showed a nearly uniform spike of 10 A for each charge. A 10 A pulse is considered normal (ref. 5). The pulse that caused the failure was 7.5 times larger. The genset failed trying to produce an 80 A pulse (imposed on the existing 30A load) in 1 second.

An explanation can be provided for the failure. The algorithm was created using a constant current discharge. When operating with the test lighthouse loads it sees a varying discharge current according to the duty cycle of the signals. The fog signal in the test lighthouse suite caused the load current to vary 6-8 A when it was on. If "C1" was selected just before the six-second fog signal "blast" and the adjustment by the algorithm to 4 A (positive into the battery) was made during the blast, the voltage adjustment would need to accommodate 12 A instead of the normal 1-2 A. Twenty to twenty-four (20-24) A pulses would be used for the remainder of the charge. A gross adjustment like this could explain the failure.

A failure of this type is easily correctable by using redundant "checking" or "limit" routines within the software to prevent fatal signals from being executed. None were provided with the algorithm. Additionally, the engine controller logic does not need the rigid policy of terminating operation because of an underspeed. In this case another attempt to start the engine after it came to rest would likely have been successful.

Data. (77 cycles, 04/26/88-05/11/88, Fig. 9, #4)

Background. The initial 29 cycles of this run were abnormal in their "shape" as defined by the charging current plotted over time. The charges rarely ramped to the 30 A level and had extended taper periods at low amperage. The early taper period is symptomatic of cell mismatches in the battery. The conditions were similar to those that led to failure in sub-test 3. These conditions also cause the genset to have extended running times. The algorithm advertises the ability to equalize cell performance without overcharging because it adjusts charging around the strongest cell as measured by voltage. Early charging did not support this claim, however cycles 29-77 regained a classic "shape" for the current curve (Figure 6, typical). The battery's ability to accept a "normal" charge had apparently improved in the last two-thirds of this period.

Diesel Duty Cycle.

240.8 eng hrs./360 total hrs. = 66.89%

Charge Periods.

Total = 77
Mean = 5.02

Discharge Periods.

Total = 77
Mean = 2.68

Fuel Usage.

Actual:

147.05 gal./240.8 eng hrs. = 0.61 gal./eng hr.

Real-time:

147.05 gal./360 total hrs. = 0.41 gal./sys hr.

Specific Consumption:

147.05 gal./1,422.07 kWh gen = 0.10 gal./kWh

Generator Power.

Average Power:

1,422.07 kWh gen/240.8 eng hrs. = 5.91 kW

Peak Power (measured) = 8.99 kW

Note: This value for total generator energy includes consumption by household loads, total for period = 70.2 kWh

Battery Efficiency.

Energy Efficiency:

(364.75 kWh out/442.18 kWh in) * 100 = 82.49%

System Efficiency.*

Energy Efficiency.

(1,087.2 kWh load/1,351.84 kWh gen) * 100 = 80.42%

Sub-test #5

The system was restarted on May 28 and failed a fifth time on June 21. The system completed 74 cycles over 25 days. The system was manually shut down because of a noticeable drop in battery capacity that accompanied erratic charges similar to those described in sub-tests 3 and 4. Figure B-2 shows a plot of the 74 discharge times. The first 50 cycles demonstrated a 25% loss in capacity. The discharge rate averaged C/6. This was unexpectedly followed by a dramatic loss in capacity during the next 24 cycles which required the sub-test to be halted. The decreasing battery capacity shown in Figure B-2 caused the diesel generator to be on for long times and contradicted the purpose of the system's design. The trend was also perplexing because the previous attempt (sub-test 4) showed the battery could "right"

* Simple arithmetic of the energy values will not sum equally for two reasons: (1) the losses in the system have not been accurately measured; and, (2) there is a possible 2% error in the watt hour meters used to measure energy. 12 meters were used to collect data, compounding any error.

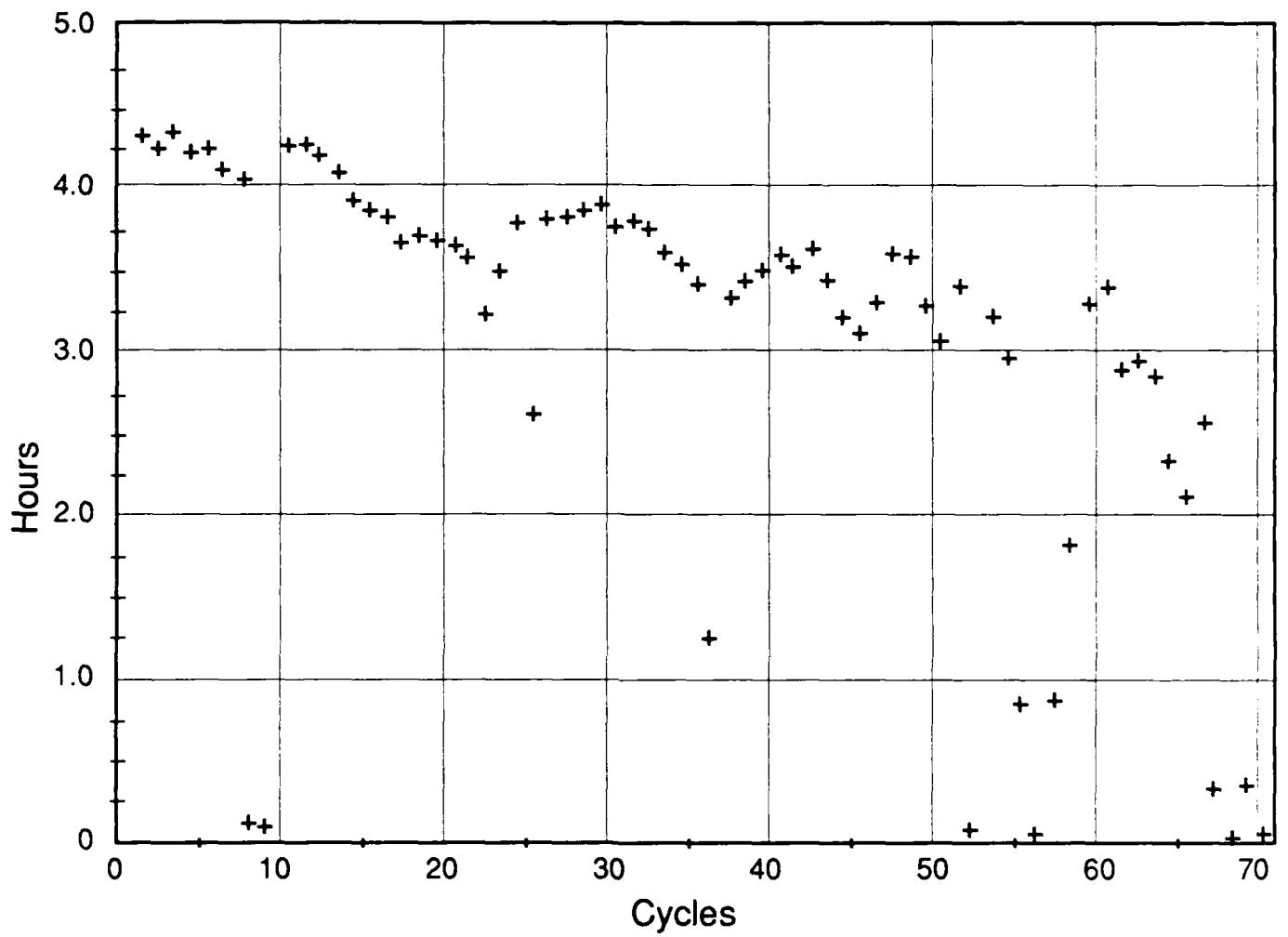

Figure B-2. Sub-test #5, Discharge Hours

itself and cycle in a uniform repeatable manner with respect to charge/discharge ratio (more commonly referred to as recharge factor). The condition of the HAGEN was suspect, but previous equalize charging had restored normal cell voltages and specific gravities.

The specific gravity readings of the electrolyte taken after manual equalize charges were 1.260 (+/- 0.030). Random readings taken on cells at the end of charges during sub-test 5 were always near 1.180. Temperatures of the electrolyte ranged from 25 to 35 degrees C. This was an alarming discrepancy because it suggested the battery was not being fully charged. No program existed for collecting specific gravity readings. Hardware for digital measurements are expensive and manual measurements are time and labor intensive. Readings on the HAGEN were made with a hand held digital meter (METTLAR-PARR) by technicians and recorded in the field notebooks. The purpose of collecting any readings was to aid in troubleshooting system conditions and not to develop a data base for density reading.

The terminal voltage of a cell is directly related to the concentration or density of the electrolyte and its temperature (ref. 10). According to Vinal the concentration affects the resistance, viscosity, and diffusion abilities of the acid. If our random readings were indicative of a real downward trend in the HAGEN's electrolyte density then they would explain the gradual loss in capacity. As the density drops, the terminal voltage drops and we have a shorter period of time available between the end of charge voltage and the 114 volt start charge criterion. Figure C-3 plots the battery's voltage at the end of charging for each cycle. The dramatic loss of voltage demonstrated in cycles 64-74 support this assumption. The algorithm appeared to not charge the battery fully. Repetitive undercharging of a lead acid battery will result in a loss of capacity.

The HAGEN was operated with an automatic electrolyte diffuser (forced air pressure). However the dense plate construction of the battery precluded specific gravity measurements on any portion of the cell except the top reservoir. Without this type of information one can only speculate that stratification played a part in the decreasing capacity. Other causes could be related to localized sulfation on the plates or contamination of the electrolyte.

At the end of this test period it was clear the HAGEN could develop a significant loss in capacity. It was also established that manual equalize charging could temporarily restore the HAGEN's capability. Equalize charging is contrary to the goals of the system because the heavy gassing produced while doing it results in water loss and increases maintenance and the probability of watering sub-system failures. During equalize charging

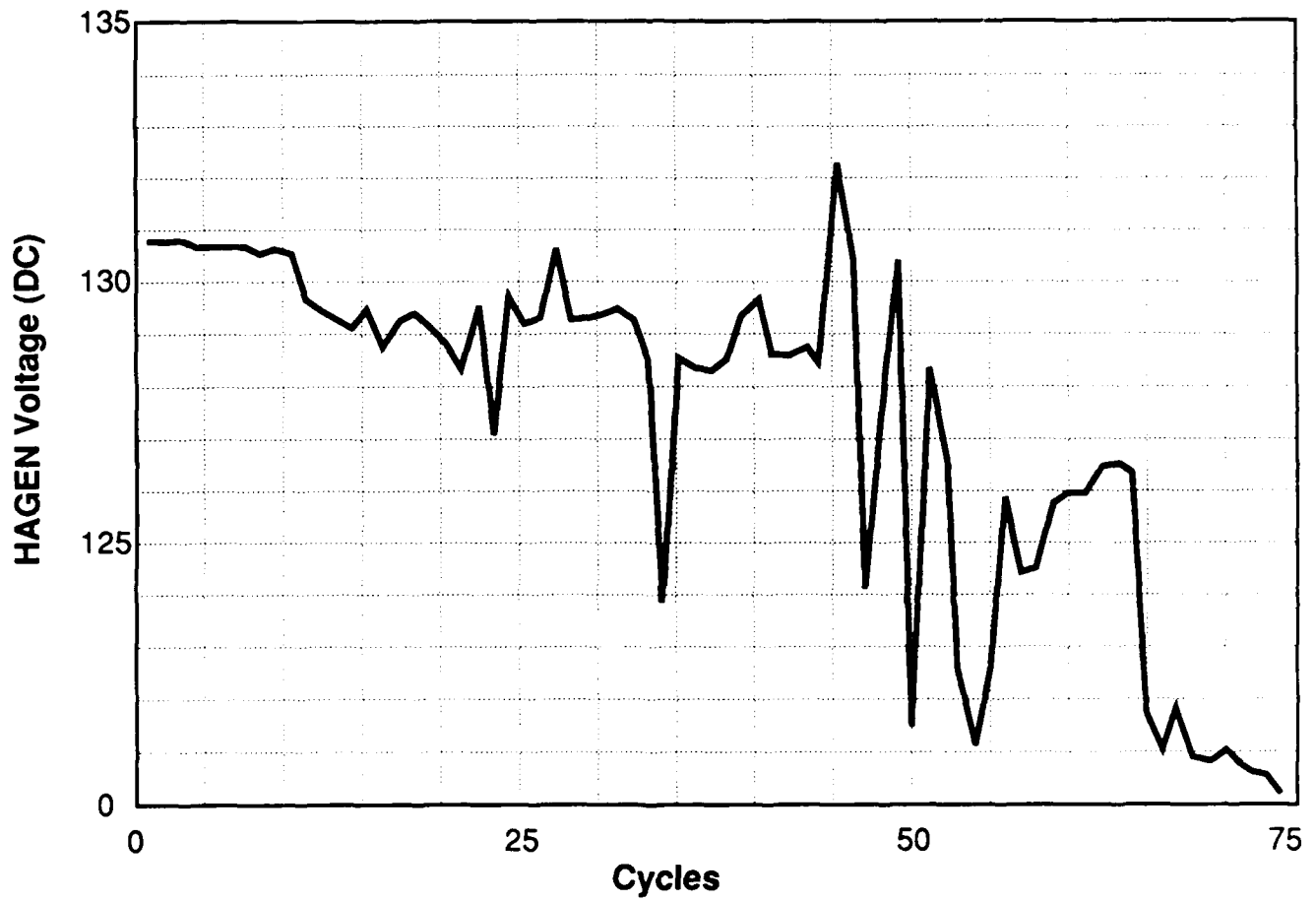

Figure B-3. Sub-test #5, End of Charge Volts

gassing caused by electrolysis diffuses the electrolyte and reduces localized action that occurs when the concentrations are not uniform within the cell. The algorithm relies on low charge rates and cell to cell monitoring to minimize gassing. The algorithm was suspected of undercharging the HAGEN. It was decided to run the system again after a manual equalize charge to see if the results could be duplicated.

Data. (74 cycles, 05/28/88-06/21/88, Figure 9, #5)

Background. The first 30 cycles in this sub-test were normal as described by the "shape" of the charge current plotted over time. That curve would ramp sharply to 30 A and then level there for about 3 hours before tapering to 2 A over 1.5 hours. Poor charges would be randomly scattered between and seemed to have no cause or effect on the HAGEN. After 50 cycles the decline in end of charge voltage became gradually noticeable. The charge curves remained normal. After 65 cycles the system was ineffective because the diesel was on for most of each day and the end of charge voltage was about 120 volts (Figure B-3).

Diesel Duty Cycle.

360.27 eng hrs./576.0 total hrs. = 62.55%

Charge Periods.

Total = 74
Mean = 4.87 hrs.
Min. = 0.17 hrs.
Max. = 11.30 hrs.
Median = 5.02 hrs.

Discharge Periods.

Total = 74
Mean = 2.89 hrs.
Min. = 0.83 hrs.
Max. = 4.33 hrs.
Median = 3.44 hrs.

Fuel Usage.

Actual.

211.32 gal./360.27 eng hrs. = 0.59 gal./eng hr.

Real time.

211.32 gal./576.00 total hrs. = 0.37 gal./sys hr.

Specific Consumption.

211.32 gal./2134.61 kWh gen = 0.10 gal./kWh

Generator Power.

Average Power.

2134.61 kWh gen/360.27 eng hrs. = 5.93 kW

Peak Power (measured). = 9.13 kW

Battery Efficiency.

Energy Efficiency.

(660.13 kWh out/754.17 kWh in) * 100 = 87.53%

System Efficiency.

Energy Efficiency.

(1723.50 kWh load/2029.53 kWh gen) * 100 = 84.92%

Note: Reduced value for total generator energy reflects consumption by household loads, total for period = 105.08 kWh

Water Usage.

The HAGEN was manually watered on June 15. The previous watering occurred on May 5. The HAGEN was watered manually because the automatic watering system was damaged in shipping. Watering was done when the electrolyte reservoir was measured to be less than $\frac{1}{2}$ inch above the tops of the plates.

<u>Cycles</u>	<u>From</u>
35	Sub-test 4 (from 05/05)
18	interval between 4 & 5
<u>47</u>	Sub-test 5 (to 06/15)
Total 100	

Total water added to HAGEN (06/15/88) = 3400 ml

Average water added to HAGEN per cell = 56.67 ml/cell

Average water per cell per cycle = 0.567 ml/cell/cycle

The electrolyte temperature during this period was measured in the 30 to 40 degree C range.

Sub-test #6

The system was manually shut down after 62 cycles on August 2. A trend toward lower capacity was evident similar to that observed in sub-test 5. The system was shut down to incorporate an equalize charge subroutine. Figure B-4 shows the downward trend in discharge times. Figure B-5 shows a relatively constant charging time for the 62 cycles.

The equalize charge was justified despite the consequences of water loss in the electrolyte because random density readings at the end of charges were less than 1.200 and the automatic watering system was already non-functioning. Other researchers have suggested equalize charges may be necessary as often as every 5-10 cycles to maintain good capacity in lead acid batteries (ref. 16).

Data. (62 cycles, 07/15/88-08/02/88, Fig. 7, #6)

Background. The 62 cycles could be described as having a good "shape" using the charge current curve as a criterion but the trend toward lower capacity was intolerable from a systems standpoint.

Diesel Duty Cycle.

308.5 eng hrs./528.0 total hrs. = 58.43%

Charge Periods.

Total = 62
Mean = 4.32 hrs.
Median = 4.83 hrs.

Discharge Periods.

Total = 62
Mean = 2.94 hrs.
Median = 3.57 hrs.

Fuel Usage.

Actual.

172.12 gal./308.5 eng hrs. = 0.56 gal./eng hr.

Real time.

172.12 gal./528.00 total hrs. = 0.33 gal./sys hr.

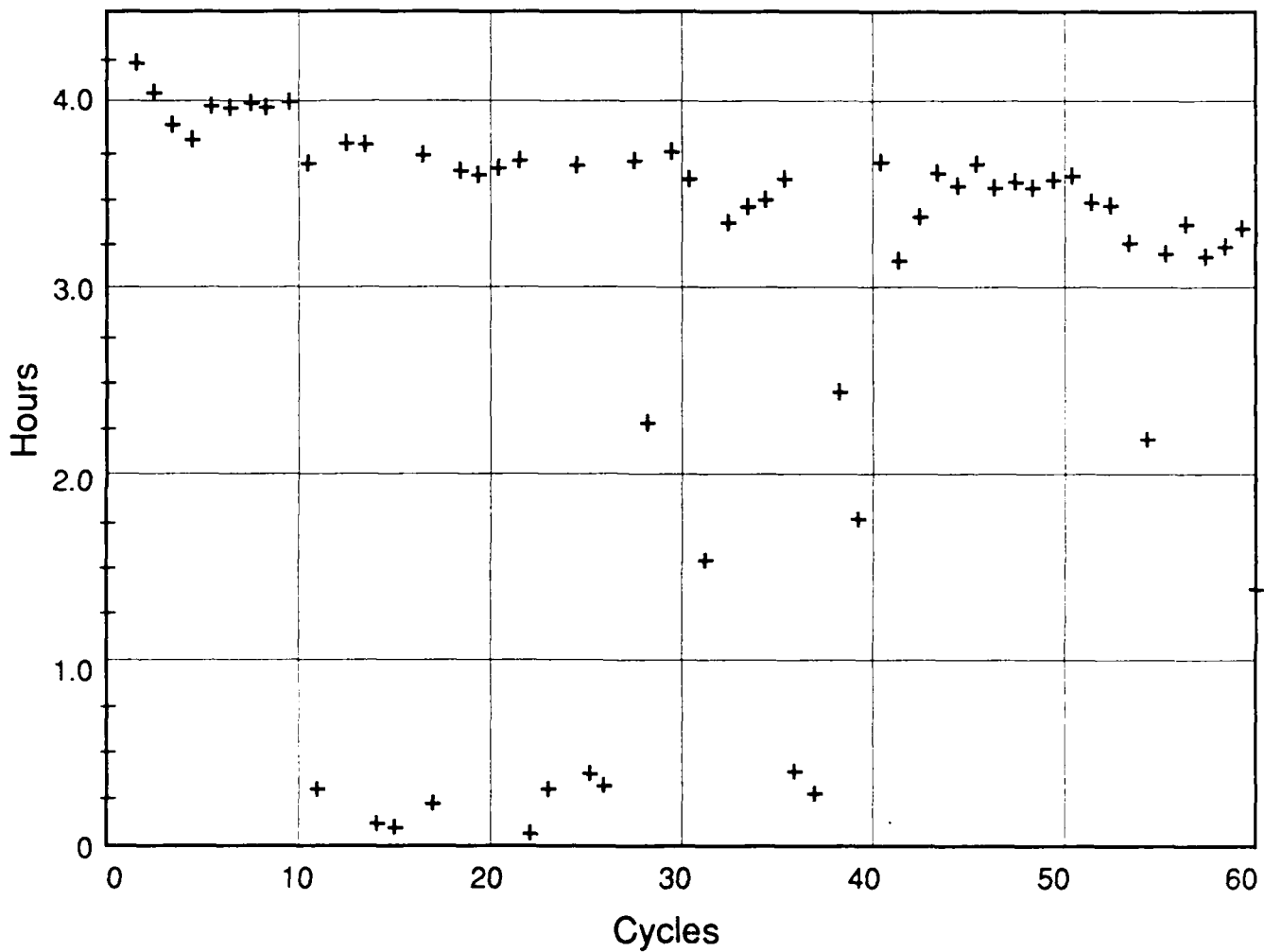

Figure B-4. Sub-test #6, Discharge Hours

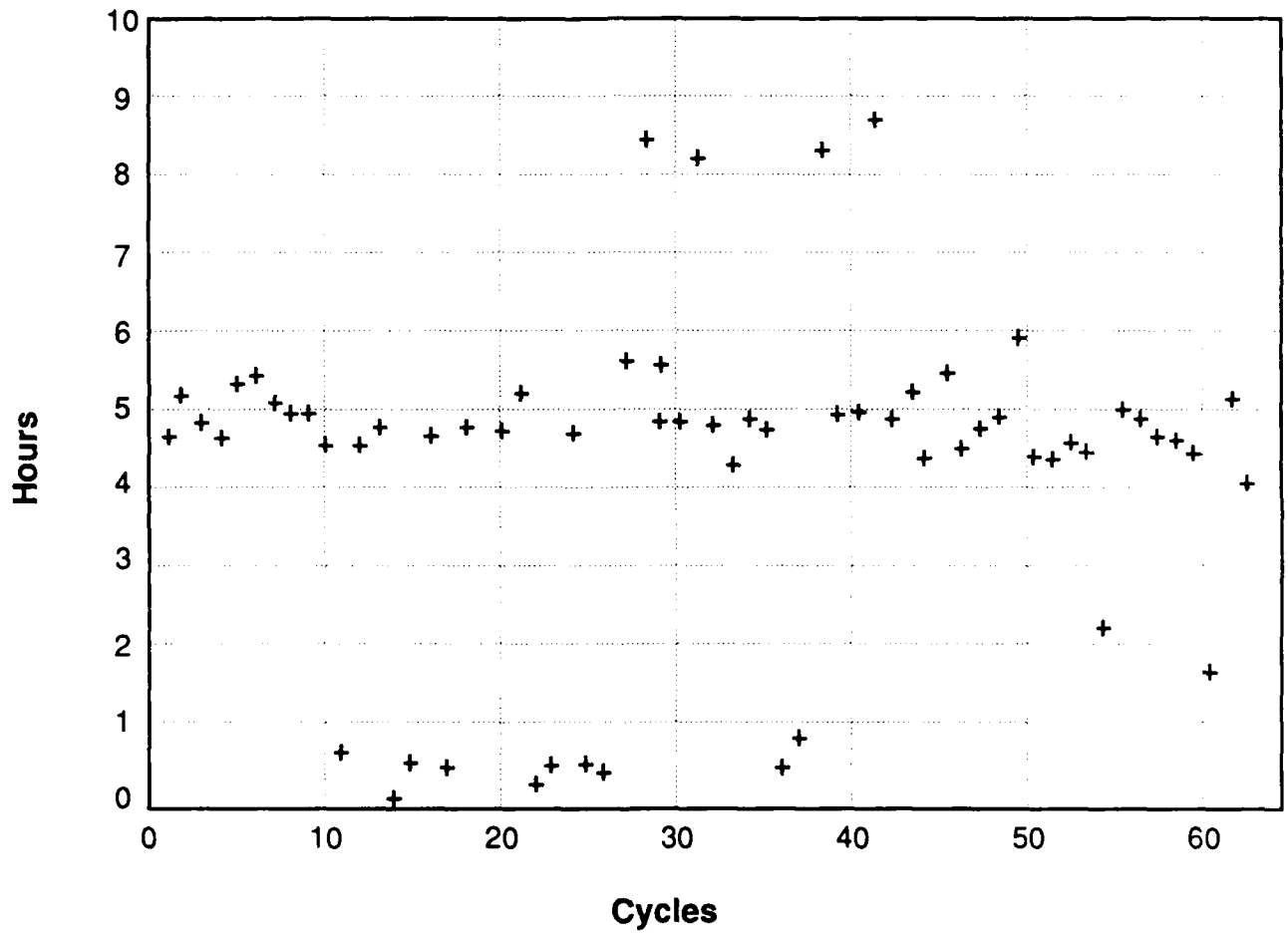

Figure B-5. Sub-test #6, Charge Hours

Specific Consumption.

172.12 gal./1930.94 kWh gen = 0.09 gal./kWh

Generator Power.

Average Power.

1930.94 kWh gen/308.5 eng hrs. = 6.26 kW

Peak Power (measured). = 8.91 kW

Battery Efficiency.

Energy Efficiency.

(671.67 kWh out/748.96 kWh in) *100 = 89.68%

Coulomb Efficiency.

(4673.19 Ah out/4837.45 Ah in) *100 = 96.60%

System Efficiency.

Energy Efficiency.

(1615.6 kWh load/1840.96 total gen kWh) *100 = 87.75%

Note: Reduced value for total generator energy reflects consumption by household loads, total for period = 89.98 kWh

Sub-test #7

Sub-test #7 was manually terminated after 150 cycles. It was begun on August 30 and ended on November 1 because the defined test period had expired. Sub-test 7 was the most successful portion of the entire test in terms of consecutive cycles, consecutive days, and reason for termination.

Figure B-6 shows the dramatic effect of the equalize charge on battery capacity. The equalize charges were completed after every tenth cycle. Disregarding the initial capacity induced by an extended manual equalize, the battery's discharge hours remain relatively constant through 80 cycles. Cycles 80-150 show a moderate decrease in capacity. All of the equalize charges elevated the battery's capacity for the next discharge.

The equalize sub-routine simply adjusted the voltage regulator's setting downward until the dc bus voltage was greater than 136.5 (2.27 VPC). This setting was held until the battery voltage was greater than 142, the charging current was less than 4 A, or the equalize charge had lasted for more than 6 hours. Figure B-7

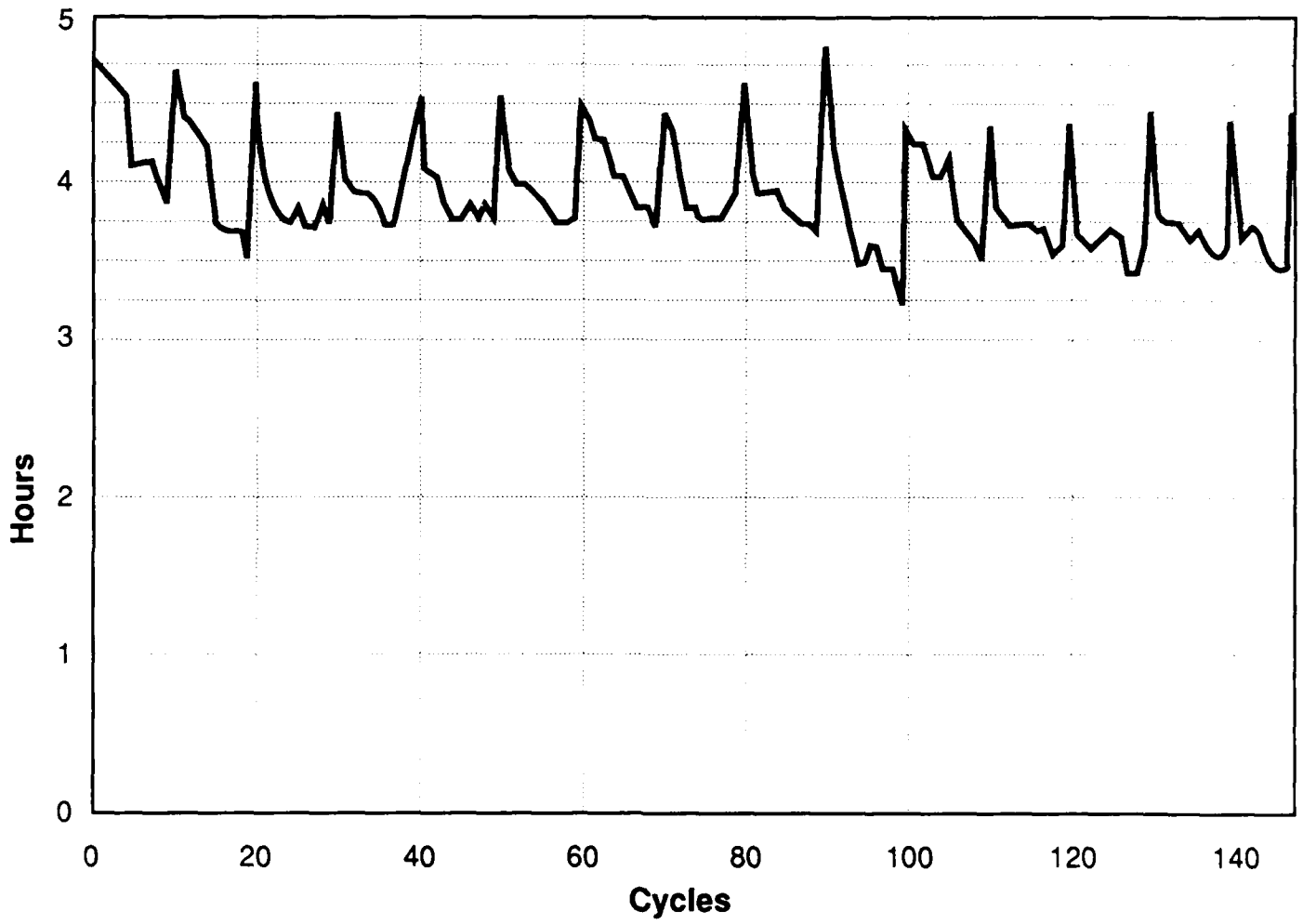
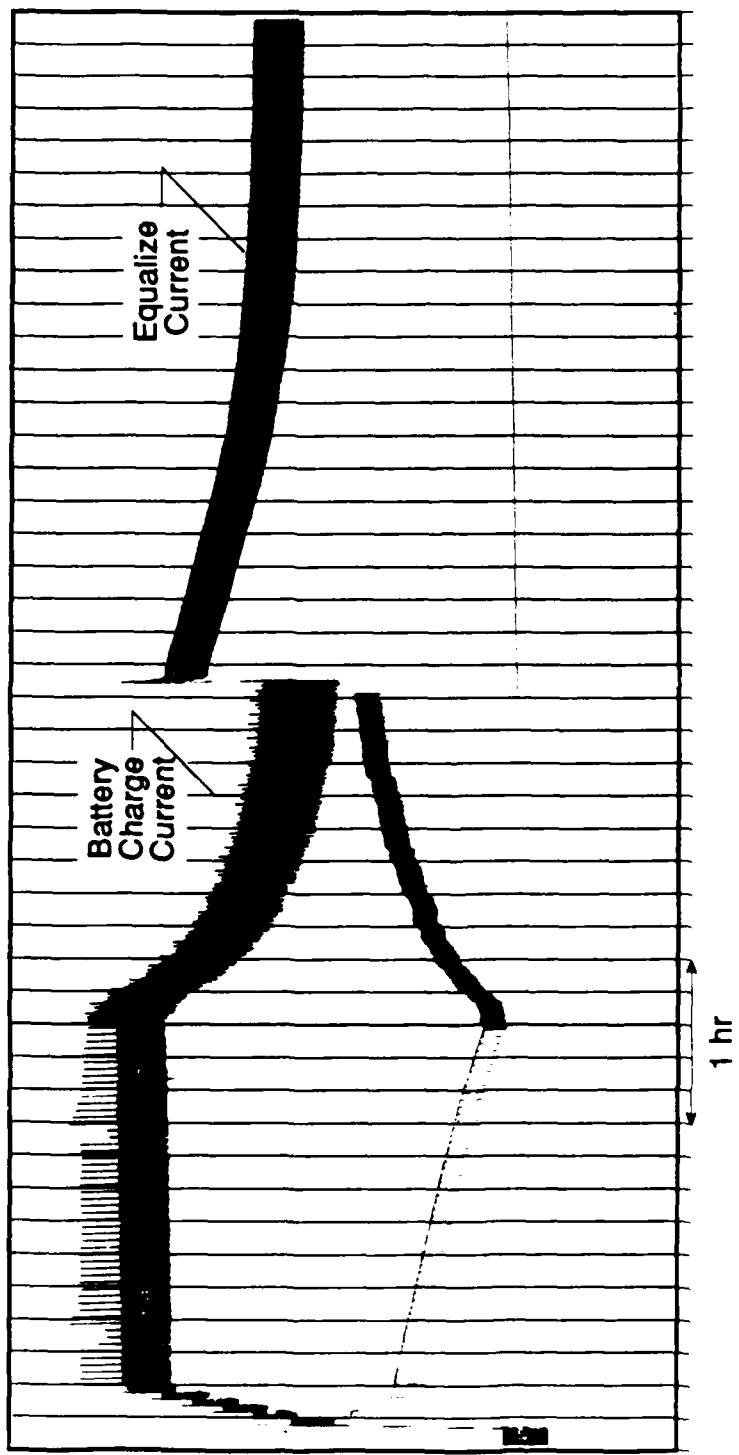

Figure B-6. Sub-test #7, Discharge Hours



Time (5 increments = one hour))

Figure B-7. Equalize Charge, Typical

shows the strip chart recording for charge #130. This particular equalize charge was typical and terminated because the charge current had fallen below 4 A.

Specific gravity readings performed randomly during the seventh sub-test showed readings near 1.240 after charges. This was a significant improvement over sub-tests where no equalize charge was deployed. The battery required water once during sub-test 7 with cells needing an average of 1.06 ml./cell/cycle. This was compared to the algorithms measured average of 0.57 ml./cell/cycle (100 cycle period). The battery consumed 5.1 liters over 78 cycles.

Data. (150 cycles, 08/30/88-11/01/88, Figure 9, #7)

Background. The 150 cycles could be defined as good using the charge curve "shape" as a criterion. The system ran consistently with little variation in the charge or discharge times.

Diesel Duty Cycle.

901.43 eng hrs./1488.0 total hrs. = 60.58%

Charge Periods.

Total = 150
Mean = 4.91 hrs.
Median = 5.59 hrs. (includes equalize charges)

Discharge Periods.

Total = 150
Mean = 3.87 hrs.
Median = 3.80 hrs.

Fuel Usage.

Actual.

522.88 gal./901.43 eng hrs. = 0.58 gal./eng hr.

Real time.

522.28 gal./1488.0 total hrs. = 0.35 gal./sys hr.

Specific Consumption.

522.28 gal./5485.1 kWh gen= 0.10 gal./kWh

Generator Power.

Average Power.

5485.1 kWh gen/901.43 eng hrs. = 6.08 kW

Peak Power (measured) = 9.44 kW

Battery Efficiency.

Energy Efficiency.

(1794.9 kWh out/2031.12 kWh in) *100 = 88.37%

System Efficiency.

Energy Efficiency.

(4553.28 kWh load/5222.18 total gen kWh) *100 = 87.19%

Note: Reduced value for total generator energy reflects consumption by household loads, total for period = 262.92 kWh

[BLANK]

•
•

APPENDIX C

[BLANK]

APPENDIX C

Figure C-1 shows typical consecutive cycles plotted by battery voltage and current over time. They are from the fifth sub-test. Figure C-2 shows the fourth cycle from Figure C-1 blown-up. The occasional misshape of the curves in current and voltage is from the effect of the fog horn power blast. The infrequency of it on these plots is due to the 15 minute sampling rate being out of synch with the horn's duty cycle.

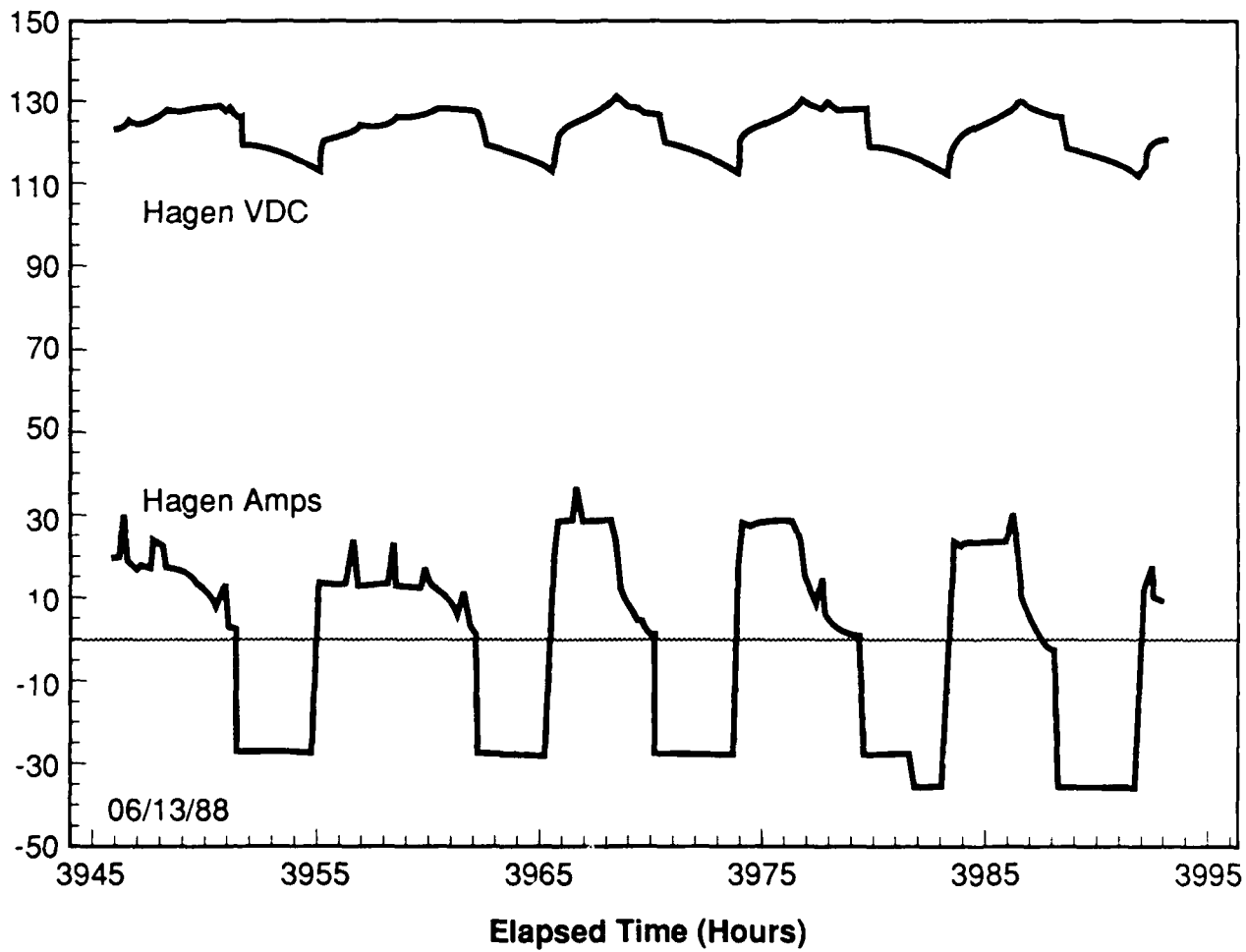

Figure C-1. Typical Cycle Information

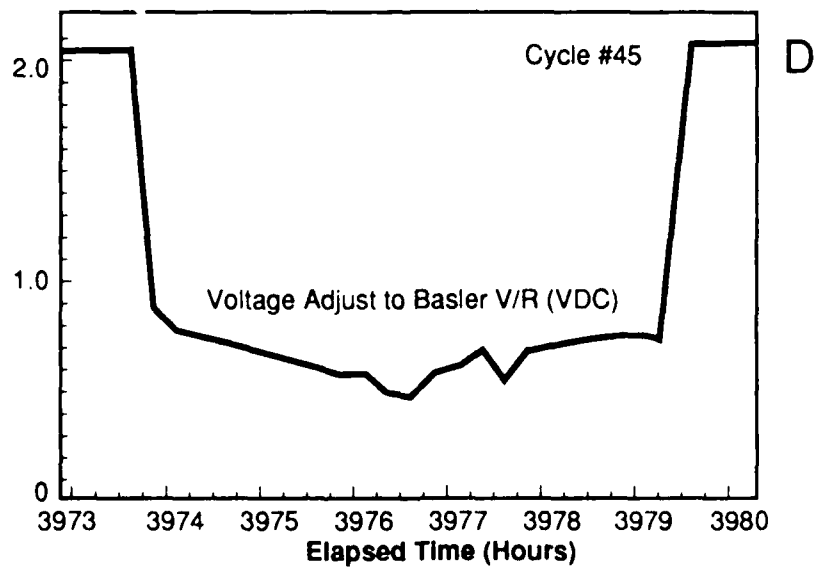
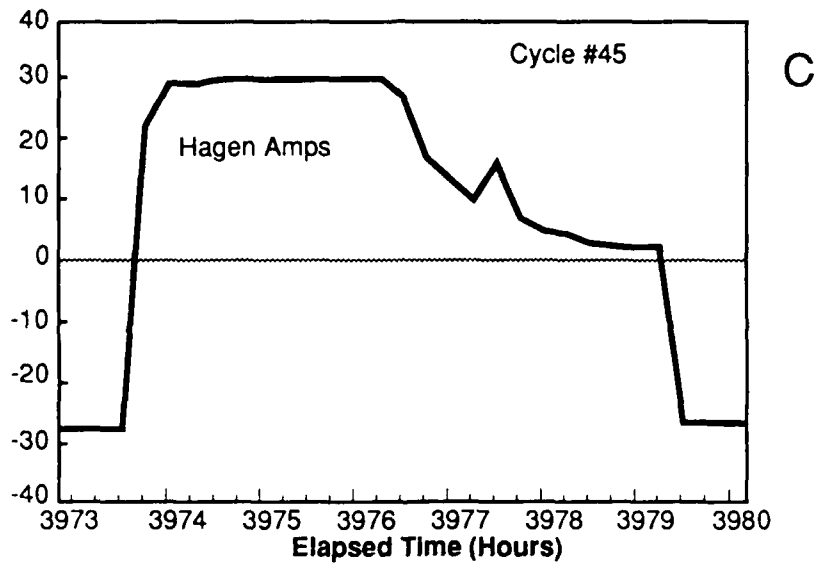
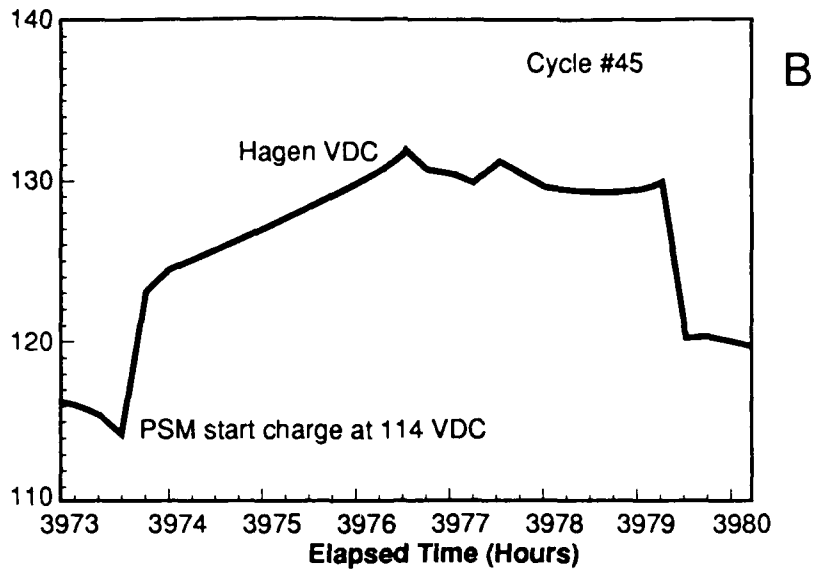

Figure C-2. Typical Cycle Information

[BLANK]