

*Hendon*

THE COPY

①

OSU

THE COMSTAR D/3 GAIN  
DEGRADATION EXPERIMENT

T.C. Lee and D.B. Hodge

State University

AD-A229 154

The Ohio State University

**ElectroScience Laboratory**

Department of Electrical Engineering  
Columbus, Ohio 43212

DTIC  
ELECTE  
DEC 06 1990  
S D D  
*CP*

Technical Report 712759-5

June 1981

Contract NASW-3393

**DISTRIBUTION STATEMENT A**  
Approved for public release  
Distribution Unlimited

National Aeronautics and Space Administration  
Washington, D.C. 20546

## NOTICES

When Government drawings, specifications, or other data are used for any purpose other than in connection with a definitely related Government procurement operation, the United States Government thereby incurs no responsibility nor any obligation whatsoever, and the fact that the Government may have formulated, furnished, or in any way supplied the said drawings, specifications, or other data, is not to be regarded by implication or otherwise as in any manner licensing the holder or any other person or corporation, or conveying any rights or permission to manufacture, use, or sell any patented invention that may in any way be related thereto.

REPORT DOCUMENTATION PAGE		READ INSTRUCTIONS BEFORE COMPLETING FORM
1. REPORT NUMBER	2. GOVT ACCESSION NO.	3. RECIPIENT'S CATALOG NUMBER
4. TITLE (and Subtitle) THE COMSTAR D/3 GAIN DEGRADATION EXPERIMENT		5. TYPE OF REPORT & PERIOD COVERED Technical
7. AUTHOR(s) T.C. Lee and D.B. Hodge		6. PERFORMING ORG. REPORT NUMBER ESL 712759-5
9. PERFORMING ORGANIZATION NAME AND ADDRESS The Ohio State University ElectroScience Laboratory, Department of Electrical Engineering Columbus, Ohio 43212		8. CONTRACT OR GRANT NUMBER(s) Contract NASW-3393
11. CONTROLLING OFFICE NAME AND ADDRESS NASA Headquarters HQ Contracts and Grants Division Washington, D.C. 20546		10. PROGRAM ELEMENT PROJECT TASK AREA & WORK UNIT NUMBERS
14. MONITORING AGENCY NAME & ADDRESS (if different from Controlling Office)		12. REPORT DATE June 1981
		13. NUMBER OF PAGES 31
		15. SECURITY CLASS. (of this report) Unclassified
		15a. DECLASSIFICATION/DOWNGRADING SCHEDULE N/A
16. DISTRIBUTION STATEMENT (of this Report)		
17. DISTRIBUTION STATEMENT (of the abstract entered in Block 20, if different from Report)		
18. SUPPLEMENTARY NOTES		
19. KEY WORDS (Continue on reverse side if necessary and identify by block number)		
20. ABSTRACT (Continue on reverse side if necessary and identify by block number) The results of gain degradation measurements performed by The Ohio State University ElectroScience Laboratory using the Comstar D/3 19.04 GHz beacon are reported. This experiment utilized 0.6 and 5 m apertures aligned along the same propagation path to examine propagation effects which are related to the antenna aperture size. Sample data for clear air, scintillation in clear air, and precipitation fading are presented. Distributions of the received signal levels and variances for both antennas are also presented. It does not appear to be possible to explain the results in terms of a simple mechanism such as angle of arrival fluctuation.		

TABLE OF CONTENTS

	<u>Page</u>
LIST OF TABLES	iv
LIST OF FIGURES	v
<u>INTRODUCTION</u>	1
<u>GAIN DEGRADATION EXPERIMENT</u>	2
Satellite Beacon	4
Ground Terminal	4
Antennas	4
Receiver	8
Data System	11
<u>OPERATIONS AND DATA</u>	12
<u>STATISTICS</u>	20
<u>SUMMARY</u>	30
<u>REFERENCES</u>	31

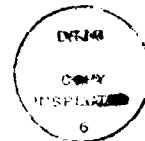

Statement "A" per telecon Philip French  
 NASA STINFO. P. O. Box 8757. BWI  
 Airport, MD 21240.

VHG

12/05/90

Accession For	
NTIS CRA&I	<input checked="" type="checkbox"/>
DTIC TAB	<input type="checkbox"/>
Unannounced	<input type="checkbox"/>
Justification	
By <i>per call</i>	
Distribution/	
Availability Codes	
Dist	Availability or Special
A-1	

LIST OF TABLES

Table		<u>Page</u>
1	LINK PARAMETERS - 19.04 GHz	11

## LIST OF FIGURES

Figure		<u>Page</u>
1	The Ohio State University ElectroScience Laboratory Satellite Communications Facility	5
2	Antenna arrangement for gain degradation experiment	6
3	Antennas for gain degradation experiment	7
4	Patterns of 0.6 m and 5 m antennas ( $f = 28.56$ GHz)	9
5	Receiver block diagram	10
6	Raw data showing received signal levels for the two antennas and the switch drive (day 227 hr 20 min 0 sec 7)	13
7	Processed data for the period shown in Figure 6 demon- strating the removal of the offset due to diurnal mo- tion (day 227 hr 20 min 0 sec 7)	14
8	Behavior of variance for a quiet data period	16
9	Variance behavior during enhanced clear air scintilla- tion	17
10	Variance behavior during enhanced clear air scintilla- tion	18
11	Variance behavior during a shallow precipitation fade event	19
12	Enhanced large aperture scintillation during onset of precipitation fading	21
13	Enhanced large aperture scintillation during onset of precipitation fading	22

Figure		<u>Page</u>
14	Enhanced large aperture scintillation during onset of precipitation fading	23
15	Enhanced large aperture scintillation during onset of precipitation fading	24
16	Variance behavior during a precipitation fade event	25
17	Variance behavior during a precipitation fade event	26
18	Fade distributions for large and small apertures	28
19	Variance distributions for large and small apertures	29

## INTRODUCTION

The increasing bandwidth requirement for data transmission and communication along with the congestion in the microwave portion of the electromagnetic spectrum have led to the development and utilization of the 20-30 GHz region of the spectrum. The use of these frequencies offers several advantages including high antenna gains with moderate physical aperture sizes, significantly larger channel bandwidths when compared with lower frequencies, and minimal atmospheric limitations when compared with infrared or optical channels. In spite of this latter advantage, the degrading effects of rainfall, clouds, atmospheric gases, and turbulence are still more severe in this portion of the spectrum than those found in the microwave region.

Without question, rain attenuation is the dominant problem in the design of reliable, high capacity links operating above 10 GHz. Much has been learned in recent years about the nature of rain attenuation and its statistical behavior. In addition, it has been observed that both cloud and turbulence produce amplitude scintillation, particularly at low elevation angles. Although this effect is not yet fully predictable, it seems to be reasonably well understood at the present time.

Both of the effects mentioned in the preceding paragraph are manifestations of a medium which is random both in space and in time. Thus, it is natural to suppose that, in addition to the fading and amplitude scintillation observed, there will be concurrent fluctuations in the phase of the wave incident upon the receiving antenna both as a function of time and of space. As a consequence of this hypothesis, a series of angle of arrival measurements were conducted by The Ohio State University's ElectroScience Laboratory utilizing the CTS 11.7 GHz beacon and the Comstar D/3 28.56 GHz beacon [1,2]. These measurements indicated that apparent angle of arrival fluctuations exceeded  $0.1^\circ$  for 0.01% of the time at both frequencies. Since these measurements were performed with a self-phased array having element separations of 1 m, it is evident that significant phase differences can occur over distances comparable

to aperture sizes typically in use. For this reason, an additional measurement was implemented to directly compare the signals received by apertures of significantly different sizes. The following report describes this experiment in detail and presents the initial results.

An additional motivation of the experiment described herein is the examination of amplitude scintillation during fade events. Previous experiments have been unable to shed light directly on this process since the fading is non-stationary and, thus, a direct determination of signal variance cannot be used to reliably characterize the fluctuations of the amplitude. In contrast, in this experiment both antennas are expected to experience almost the same fading due to absorption and scatter on the path. Therefore, even though the signals are still non-stationary, their variances may be compared meaningfully.

In the following, the experiment is described and the results obtained using the Comstar D/3 beacon are presented.

#### GAIN DEGRADATION EXPERIMENT

This experiment was designed to provide a direct comparison of the antenna gains realized by 0.6 and 5 m antennas operating on a 28 GHz earth-space path. In order to minimize the effect of spatial decorrelation due to separation of the two antennas, the two antennas were mounted coaxially with one in front of the other. This was accomplished without introducing additional aperture blockage by mounting a 0.6 m focal point feed antenna in front of the subreflector of a 5 m Cassegrainian fed antenna. Thus, the antennas shared the same physical and electrical bore-sights. The signals from these two antennas were switched in a manner analogous to that used in a conventional Dicke radiometer. This switching alternately fed the respective signals to a common front end and PLL receiver, thus eliminating uncertainties arising from such causes as receiver drift. The details of this experimental arrangement will be described in the following.

The 28.56 GHz gain degradation experiment was implemented in August, 1979; however, the mixer-preamp purchased for this application was found to be defective and was returned to the manufacturer for repair. The repaired system became operational in January, 1980. Unfortunately, the spring rainfall was abnormally low in 1980, limiting the amount of useful data obtained. Then, in May 1980, a direct lightning strike to the X-band scanning radar caused severe damage to both the radar and the gain degradation digital data system. As the repairs to these systems were being completed, the Comstar D/3 28.56 GHz beacon was shut down on June 11, 1980.

At this point in time, the decision was made to convert the front end RF hardware for operation with the Comstar D/3 19.04 GHz beacon. This was made possible through the use of a new 19.04 GHz mixer-preamp provided by Intelsat. Although this new arrangement permitted the experiment to continue, a considerable loss of sensitivity was incurred due to the decrease in frequency. This is a result of the fact that the 5 m antenna is only 289 wavelengths in diameter at this frequency and has a beamwidth in excess of  $0.2^{\circ}$ . Nevertheless, it was felt that the experiment should proceed under these conditions since a measurement of this type had never been performed before.

The 19.04 GHz experiment became operational on July 27, 1980, and continued until the Comstar D/3 beacon was permanently shut down on September 1, 1980. Fortunately, during this time period an excellent data set was obtained. Twenty-seven rain events and eighteen periods of enhanced clear air scintillation were recorded during this period. Therefore, the following will concentrate on the 19 GHz measurements during this period.

Concurrent with this effort, simultaneous measurements of radar backscatter at 3 GHz and radiometric temperature at 8 GHz were made along the same propagation path. These measurements were supported by Intelsat under Contract INTEL-066. The preliminary results of these measurements

are reported in References [3] and [4].

### Satellite Beacon

The Comstar C/3 19.04 GHz beacon transmitted an EIRP of +21 dBw with switched linear polarization. The long term frequency stability of this beacon was specified to be better than one part in  $10^6$ , and the short term stability was specified such that 90 percent of the transmitted power was to be contained within a band of 100 Hz.

The 19.04 GHz beacon transmitted two orthogonal linear polarizations which were switched at a rate of 1 KHz. The narrow receiving bandwidth of 85 Hz used in this experiment rejected the switching sidebands. Thus, a power loss of 6 dB was incurred as a consequence.

### Ground Terminal

The ground terminal was located at The O.S.U. ESL Satellite Communications Facility in Columbus, Ohio. This site is located at a latitude of  $40^{\circ}00'10''N$ , longitude of  $83^{\circ}02'30''W$ , and elevation of 252 m above mean sea level. A photograph of the Satellite Communications Facility is shown in Figure 1.

### Antennas

This gain degradation experiment utilized an existing 5 m Cassegrainian fed parabolic antenna. A 0.6 m focal point feed antenna was mounted in front of the subreflector of the 5 m antenna as shown schematically in Figure 2. A photograph of these antennas is shown in Figure 3.

The nominal azimuth and elevation for the D/3 propagation path were  $189^{\circ}$  and  $44^{\circ}$ , respectively. After the 5 m antenna was accurately boresighted on the satellite propagation path, the 0.6 m antenna pointing was adjusted so that its pattern maximum coincided with that of the 5 m

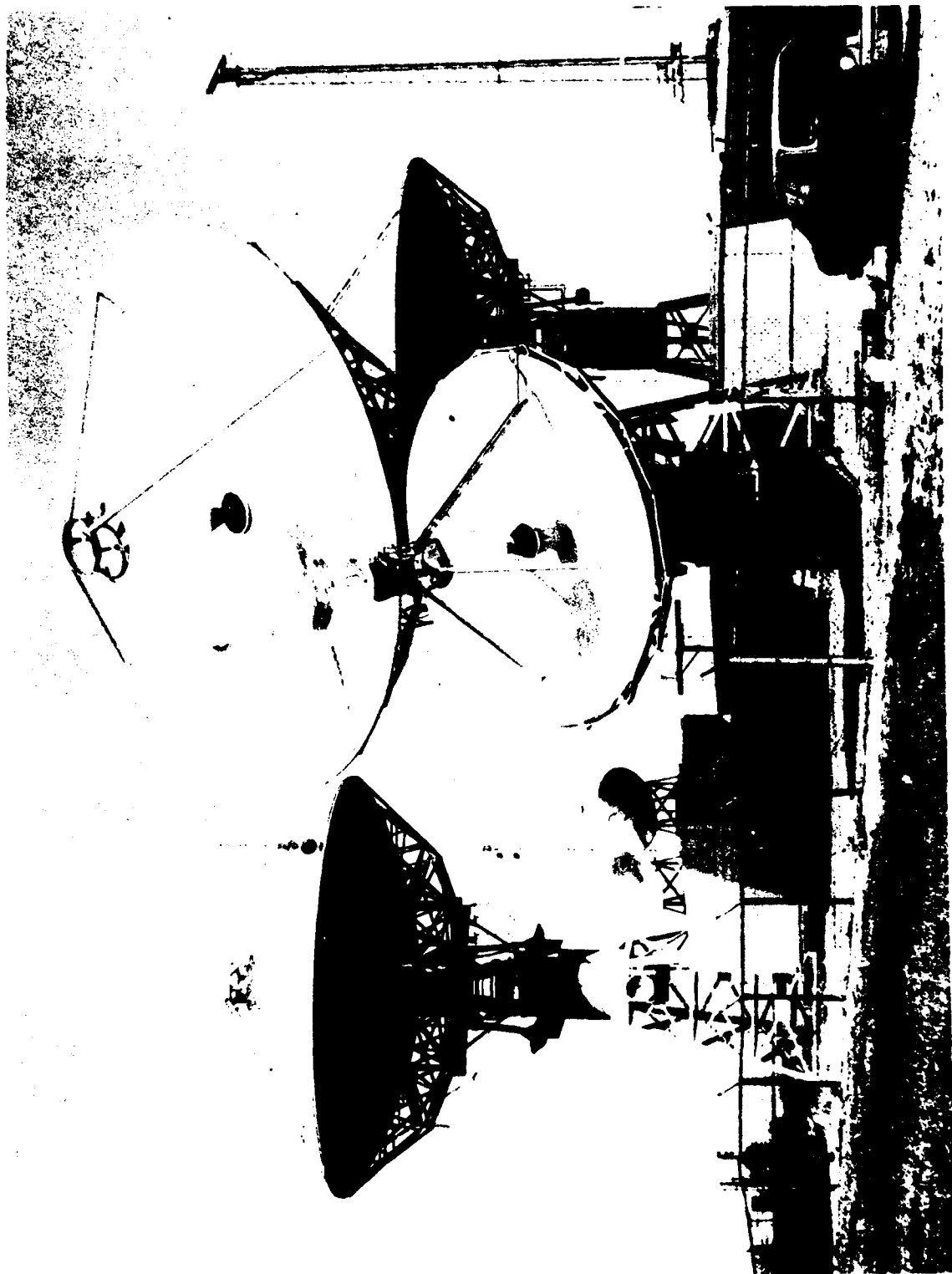

Figure 1. The Ohio State University ElectroScience Laboratory Satellite Communications Facility.

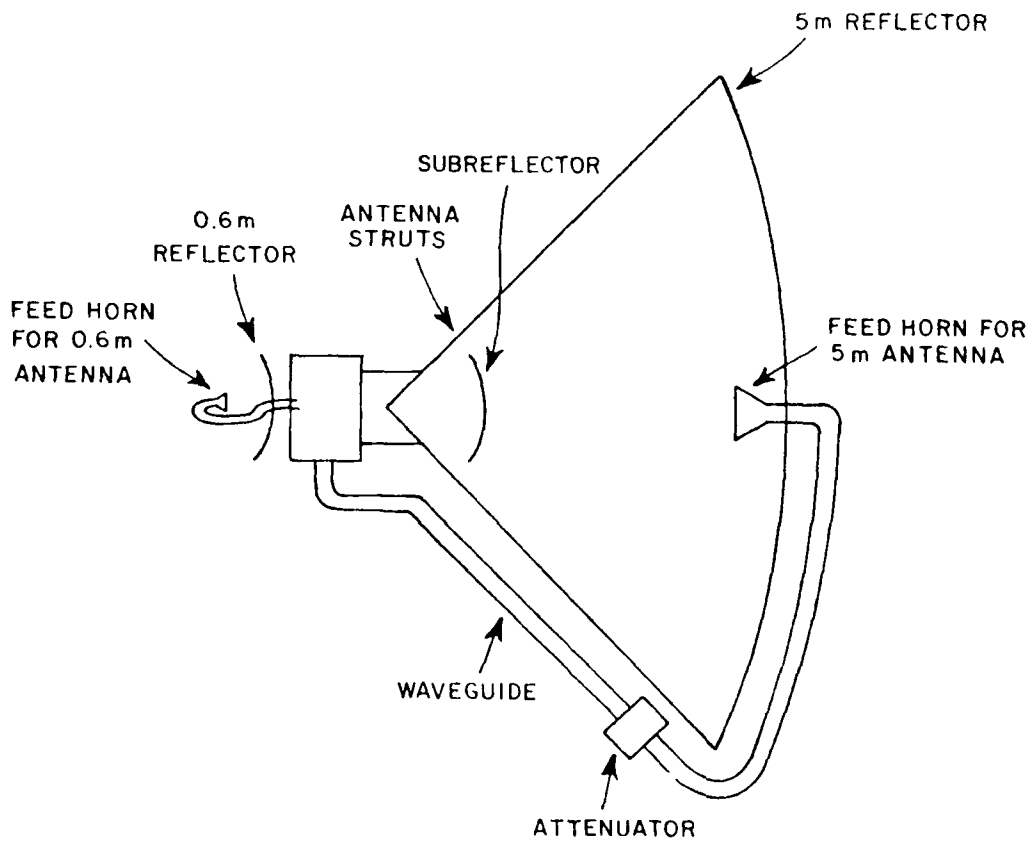

Figure 2. Antenna arrangement for gain degradation experiment.

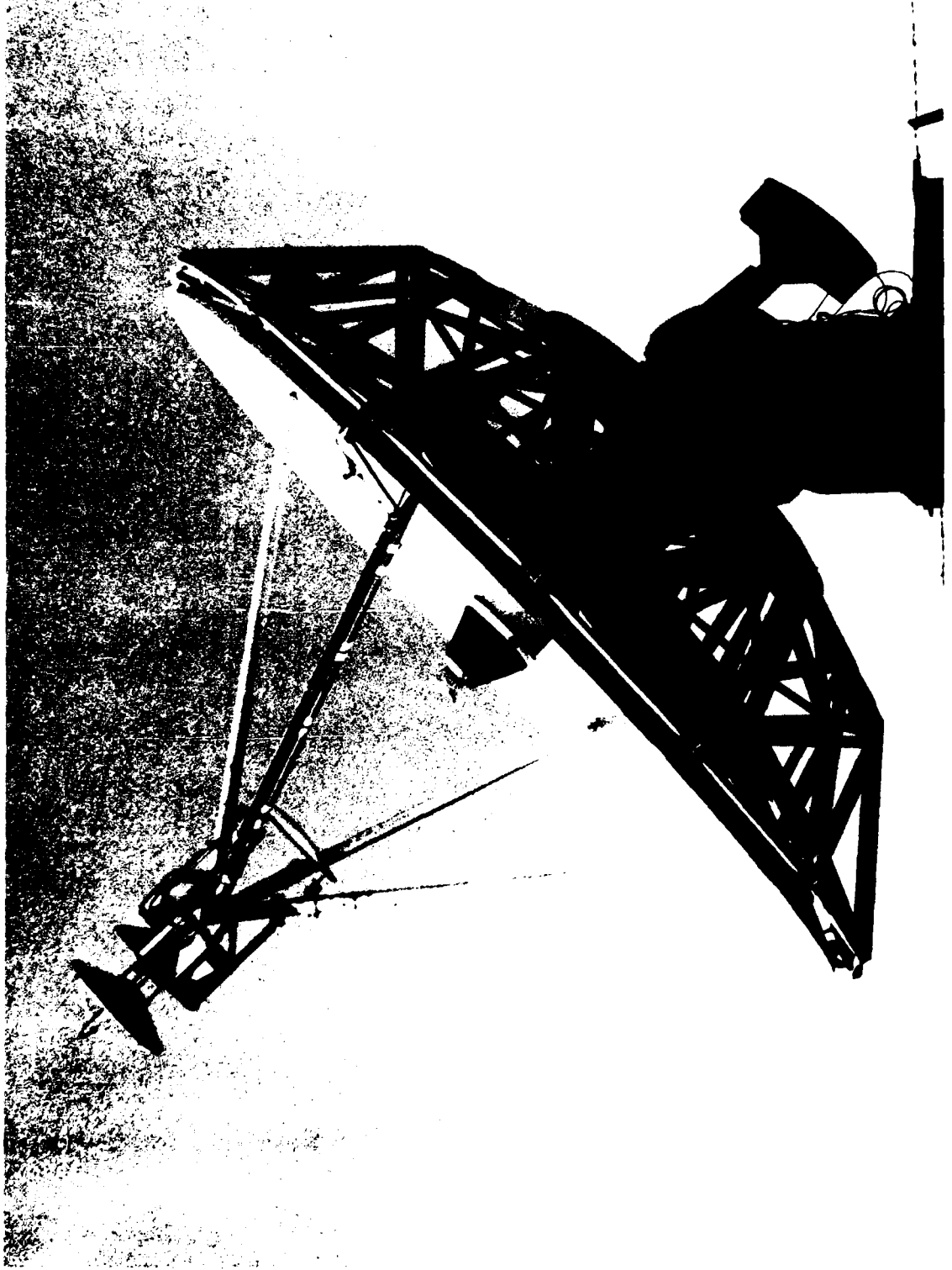

Figure 3. Antennas for gain degradation experiment.

antenna. Patterns of these two antennas are shown in Figure 4. The 3 dB beamwidths of these antennas are

	<u>AZ</u>	<u>EL</u>
0.6 m	3.0 <sup>o</sup>	1.95 <sup>o</sup>
5 m	0.36 <sup>o</sup>	0.36 <sup>o</sup>

The polarization of both antennas was vertical. Two steel struts were welded on the frame of the 5 m antenna so that it was held in position accurately during these measurements and was not susceptible to wind buffeting.

The gains of these antennas were 38.7 and 56.2 dB for the 0.6 m and 5 m apertures, respectively. During operations, a pad was inserted in the waveguide for the 5 m antenna feed horn; this pad was adjusted so that the signals received by the two antennas were as nearly equal as possible. Thus, in effect, two antennas having equal gains but different beamwidths were utilized.

#### Receiver

A ferrite switch was used to alternately select one of the two antenna ports as shown in Figure 5. This switch was reversed every 30 seconds so that the signals received by the two different apertures could be compared over relatively short time intervals. The entire receiver chain beyond this switch was common to both antennas so that the relative comparisons were insensitive to receiver drift and gain changes.

The front end mixer-preamp had a noise figure of 4.6 dB and produced an IF of 1.05 GHz. The 1.05 GHz was then brought into the equipment building by means of coax and delivered to a Martin-Marietta PLL receiver. The received signal was subsequently down converted to 60 MHz, 10 MHz, and finally 2.5 KHz for detection. The data bandwidth was 85 Hz. The link parameters are tabulated in Table 1; here, the system margin is found to be 22 dB.

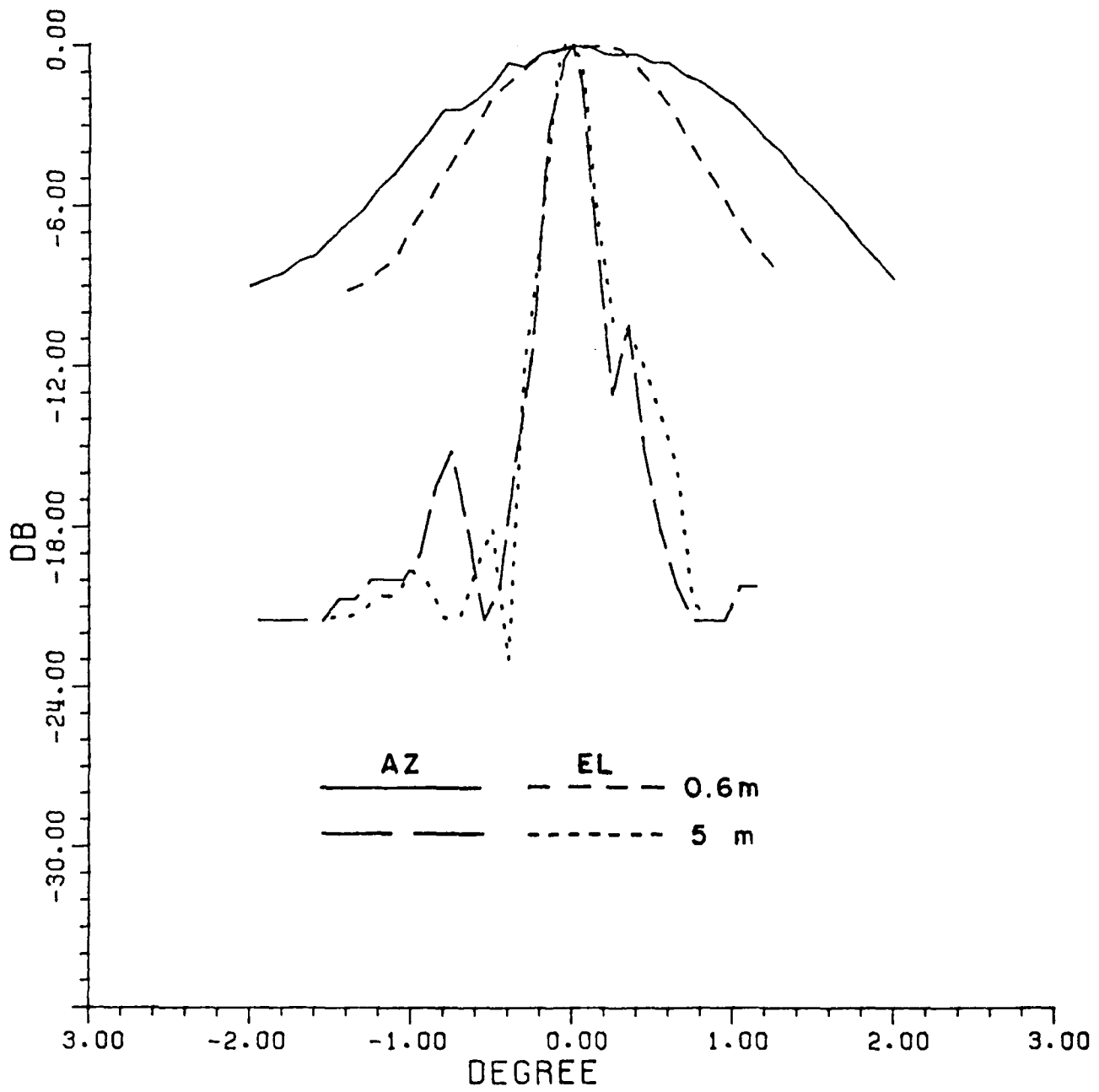

Figure 4. Patterns of 0.6 m and 5 m antennas ( $f = 28.56$  GHz).

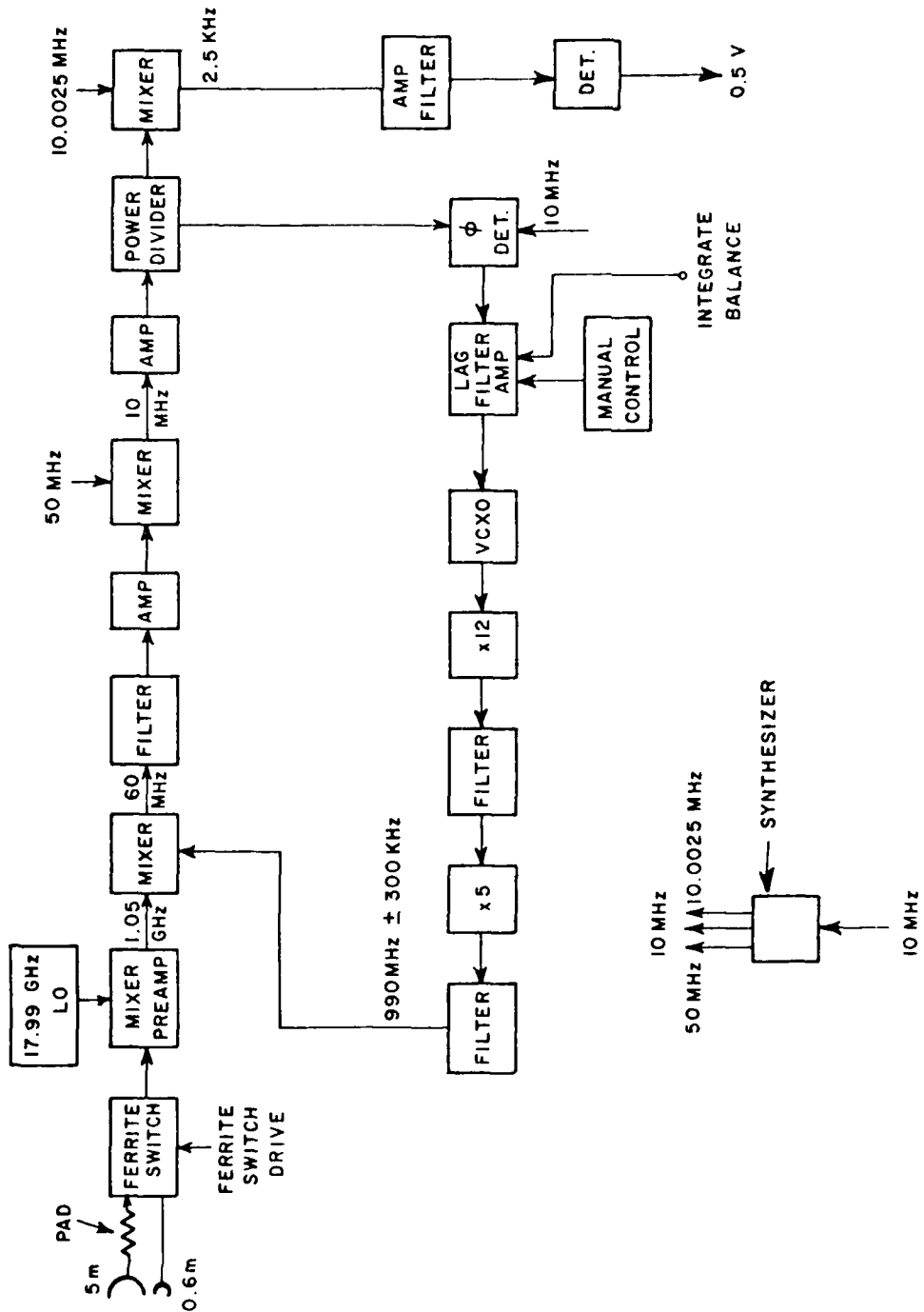

Figure 5. Receiver block diagram.

TABLE 1  
LINK PARAMETERS - 19.04 GHz

EIRP	51.0 dBm
Free space path loss	-209.1 dB
Clear air gas loss	-1.1 dB
Ground antenna gain	38.7 dB
W/G loss	-2.0 dB
Polarization switching loss	-6.0 dB
Received signal level	-125.5 dBm

Noise figure = 46 dB

Bandwidth = 85 Hz

S/N	22.0 dB
-----	---------

#### Data System

The 0-5 volt output of the receiver was sampled every three seconds so that ten samples were obtained from each antenna before switching to the other antenna. These samples were digitized by an 8-bit A/D and then delivered to the data system. The ferrite switch drive signal was simultaneously sampled and digitized so that each received signal sample could be associated with the proper antenna. A high level on this channel indicates that the 5 m antenna was active.

These two data channels along with the other radar, radiometer, and station keeping data were processed by a data system consisting of HP-2115 and LSI-2 minicomputers and a Pertec 9-track digital tape deck. The details of this data system and record formats are given in Reference [5], with the exception that the following additional channel assignments were used for this experiment:

- Channel 15 - Receiver output for gain degradation experiment
- Channel 16 - Ferrite switch drive

### OPERATIONS AND DATA

As noted earlier, twenty-seven rain events and eighteen periods of enhanced clear air scintillation were recorded during the data period. These events were studied in detail to determine any differences between the received signal levels and variances for the two apertures.

Since the satellite was not absolutely stationary, its diurnal motion produced small variations in the level of the signal received by the 5 m antenna. These variations tend to be relatively slow and smooth, having a period of 24 hours. Thus, this effect can be removed readily in the process of data analysis. Of course, this variation could also have been eliminated by means of active tracking. However, it was believed to be essential that wind buffeting effects be eliminated by rigidly fixing the antenna pointing.

A sample of raw data is shown in Figure 6 where the received output voltage is shown on the upper trace and the switch drive is shown in the lower trace. The high switch drive level corresponds to the 5 m antenna and the lower level to the 0.6 m antenna. Thus, it is clear that the signal level received by the 5 m antenna is slightly higher in this case. This offset was eliminated by averaging 100 samples at the beginning and end of the data period for each antenna. These averages were then used to establish a linear offset between the two antennas which was then removed during processing. The 0.6 m antenna level was established as the reference. Figure 7 shows the results of this processing for the case shown in Figure 6. Clearly, the offset has been eliminated and the resulting deviations are found to be quite small, on the order of a few tenths of a decibel.

The variance of each signal was also computed for every thirty second time period. These variances are normalized to the average power

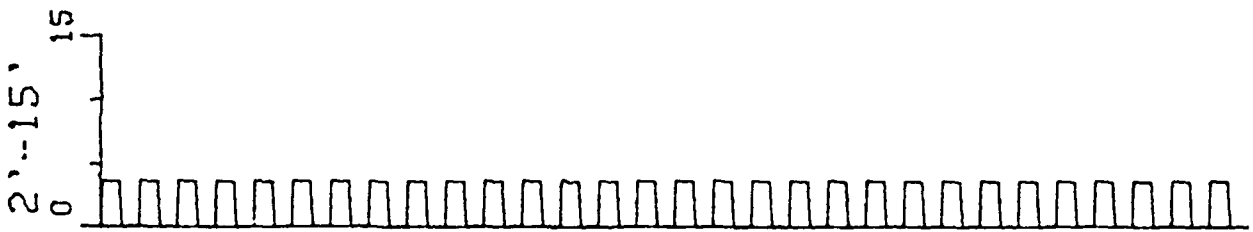
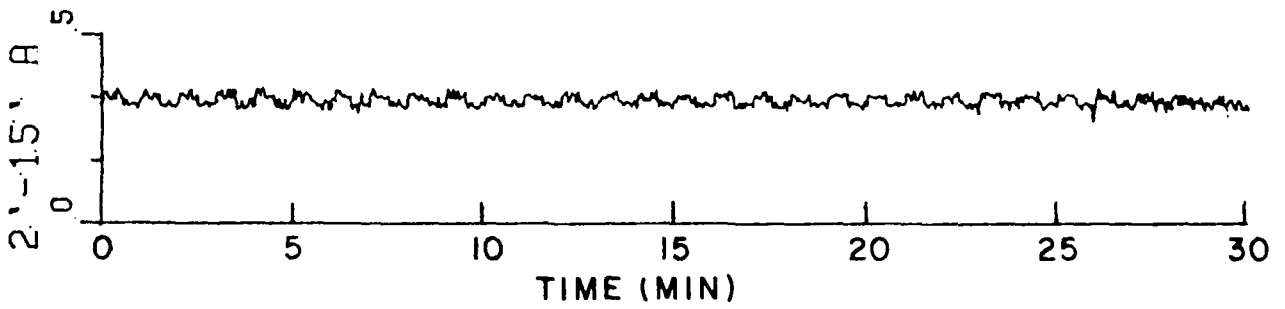

Figure 6. Raw data showing received signal levels for the two antennas and the switch drive (day 227 hr 20 min 0 sec 7). The units on the upper ordinate are volts.

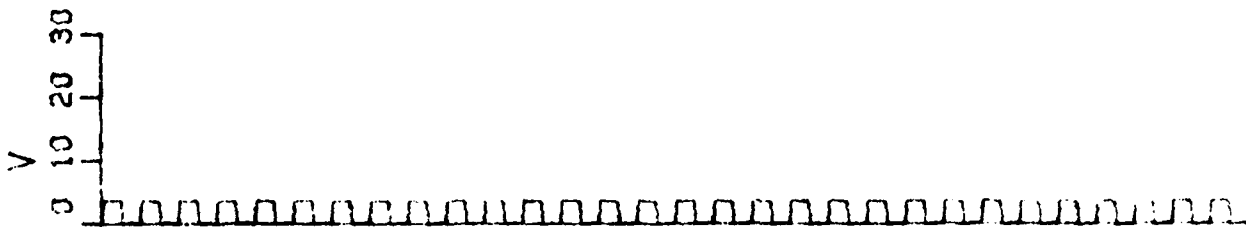
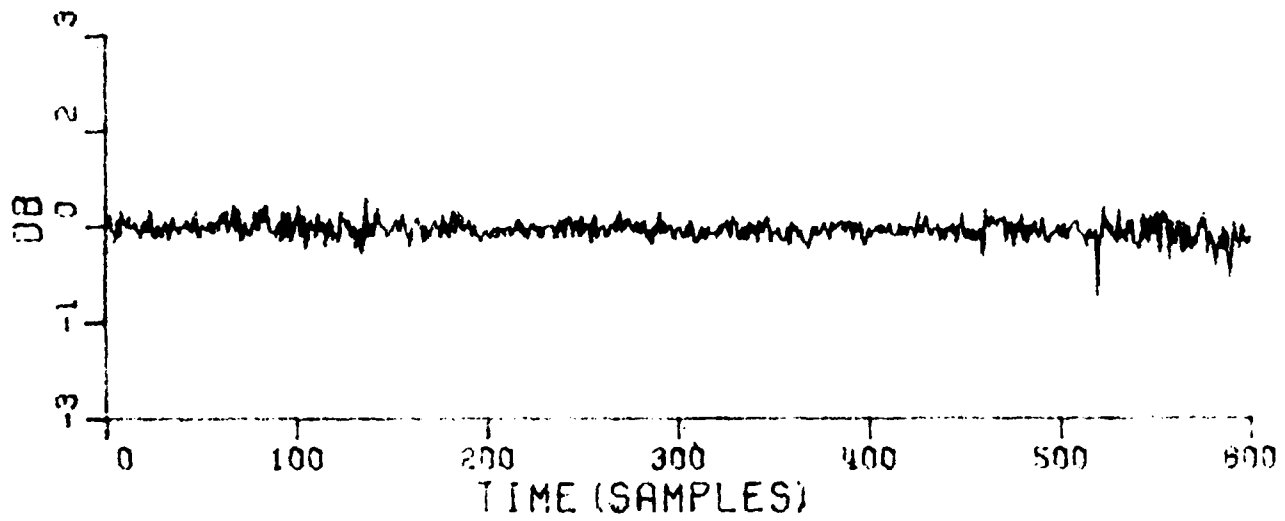

Figure 7. Processed data for the period shown in Figure 6 demonstrating the removal of the offset due to diurnal motion (day 227 hr 20 min 0 sec 7).

level of the signal over the same time period. This normalized variance is a measure of the ratio of the power in the fluctuating component of the signal to the power in the steady component of the signal. The normalized variance is given in decibels by

$$\sigma_{dB}^2 = 10 \log_{10} \frac{\sum_{i=1}^N (v_i - \bar{v})^2}{N\bar{v}^2}$$

where

$$\bar{v} = \frac{1}{N} \sum_{i=1}^N v_i,$$

$$N = 10,$$

and  $v_i$  is the  $i^{\text{th}}$  sample of the received signal. A sample of these calculations is shown in Figure 8. Here the variances of both received signals are on the order of -40 dB for a time period when the troposphere was relatively quiet.

Examples of the temporal behavior of the signal variances are shown in Figures 9 and 10 for time periods when clear air scintillation was in evidence. In both of these cases, the variance levels were on the order of -35 to -40 dB prior to the onset of enhanced scintillation and increased to about -20 dB. The increase occurred rapidly in about two minutes for the case shown in Figure 9 and gradually over twenty minutes for that shown in Figure 10. Similarly, enhanced scintillation during a very shallow precipitation fade event is shown in Figure 11. In all of these cases, the behavior of the variances of the signals received by the two antennas appear to be indistinguishable. Amplitude scintillation of this type is almost always associated with the passage of cumulus clouds through the propagation path.

Perhaps the most interesting result of these measurements was the occurrence of enhanced scintillation during the onset of precipitation

DAY 235      HR 1    MIN 31    SEC 33    MSEC 94

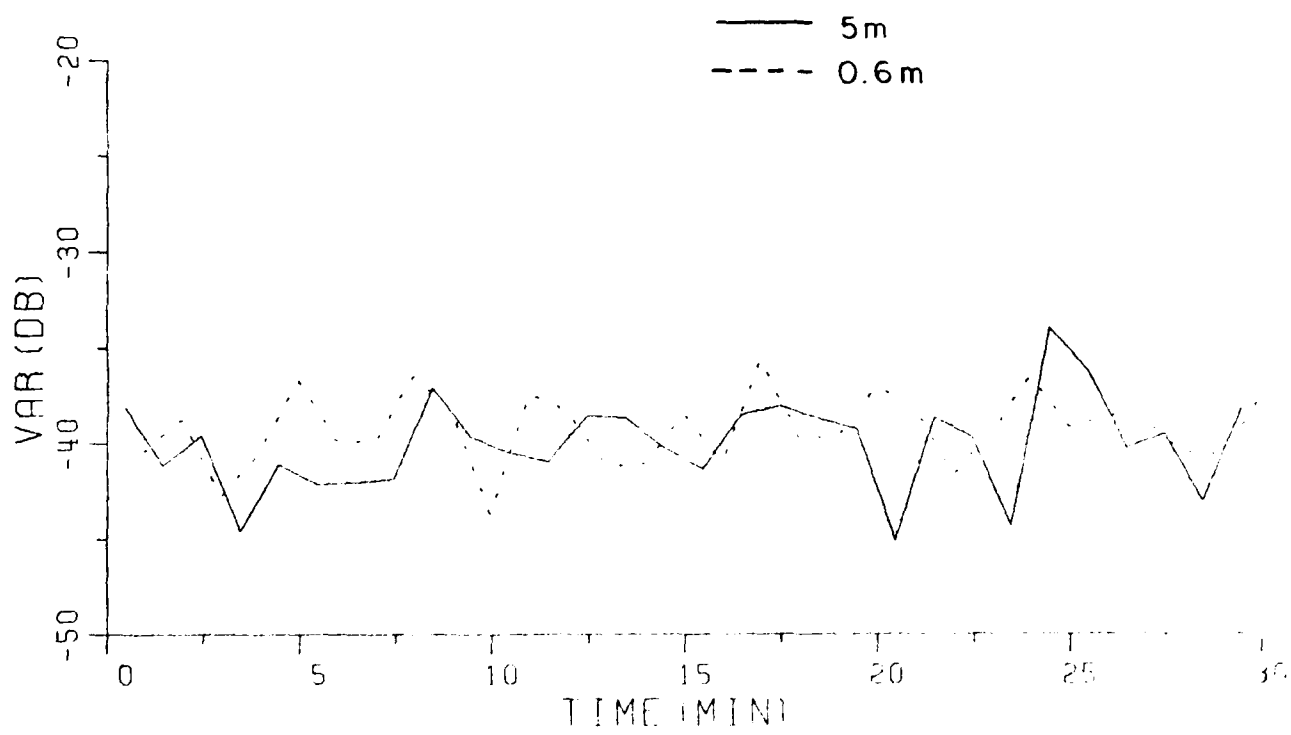
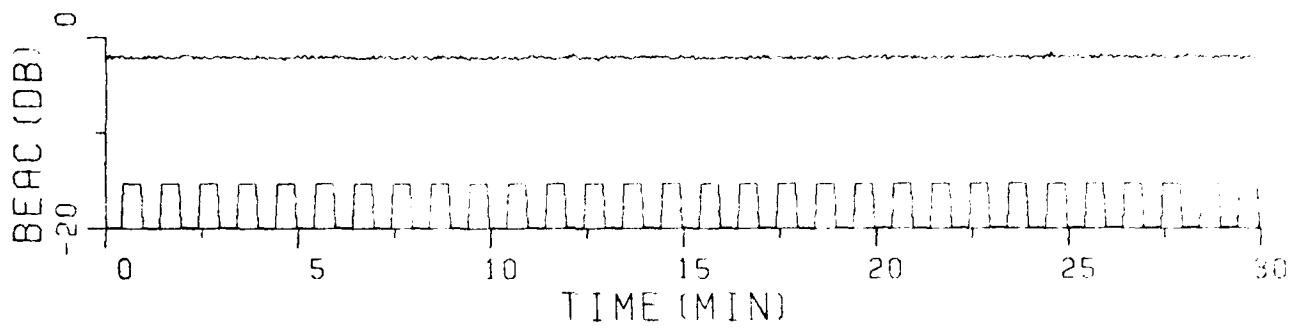
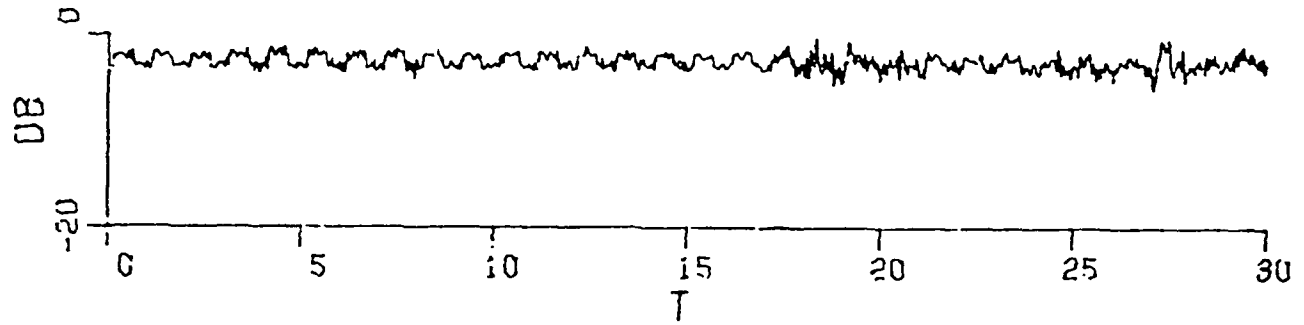

Figure 8. Behavior of the variance for a quiet data period.

DAY 219 HR 18 MIN 30 SEC 24



— 5m  
- - - 0.6m

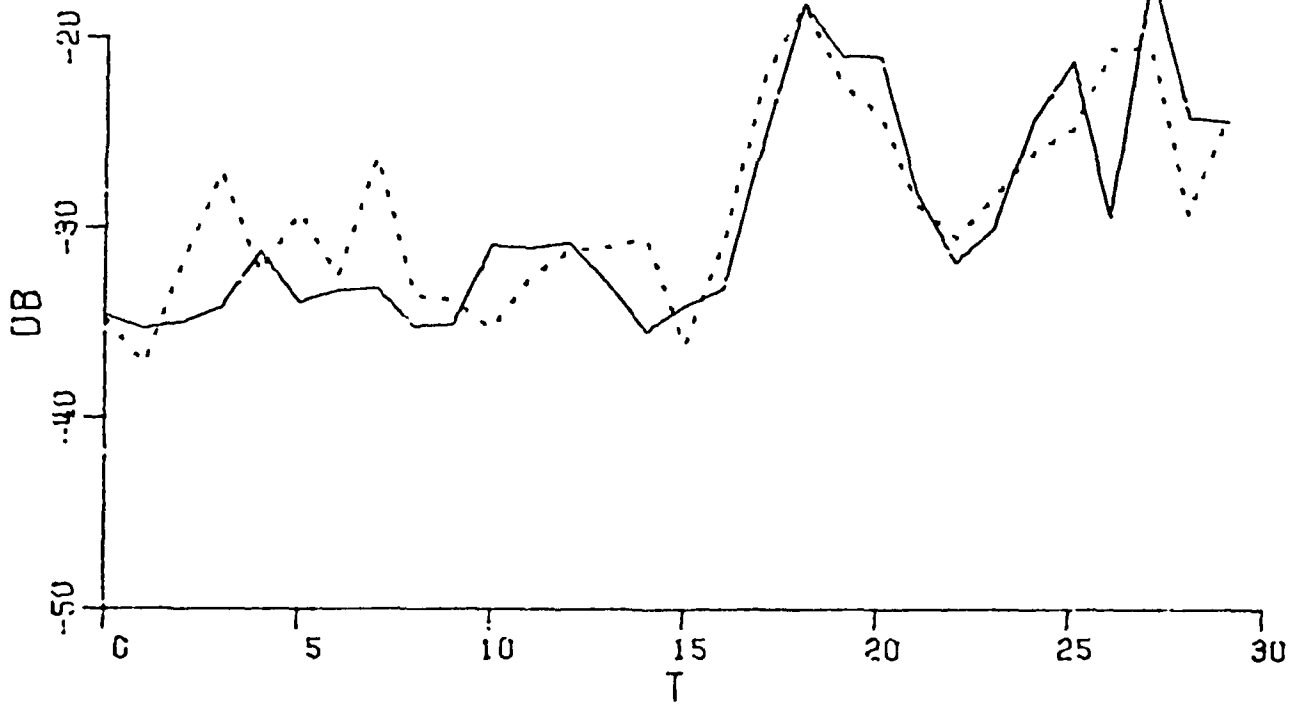

Figure 9. Variance behavior during enhanced clear air scintillation.

DAY 235 HR 1 MIN 31 SEC 33 MSEC 94

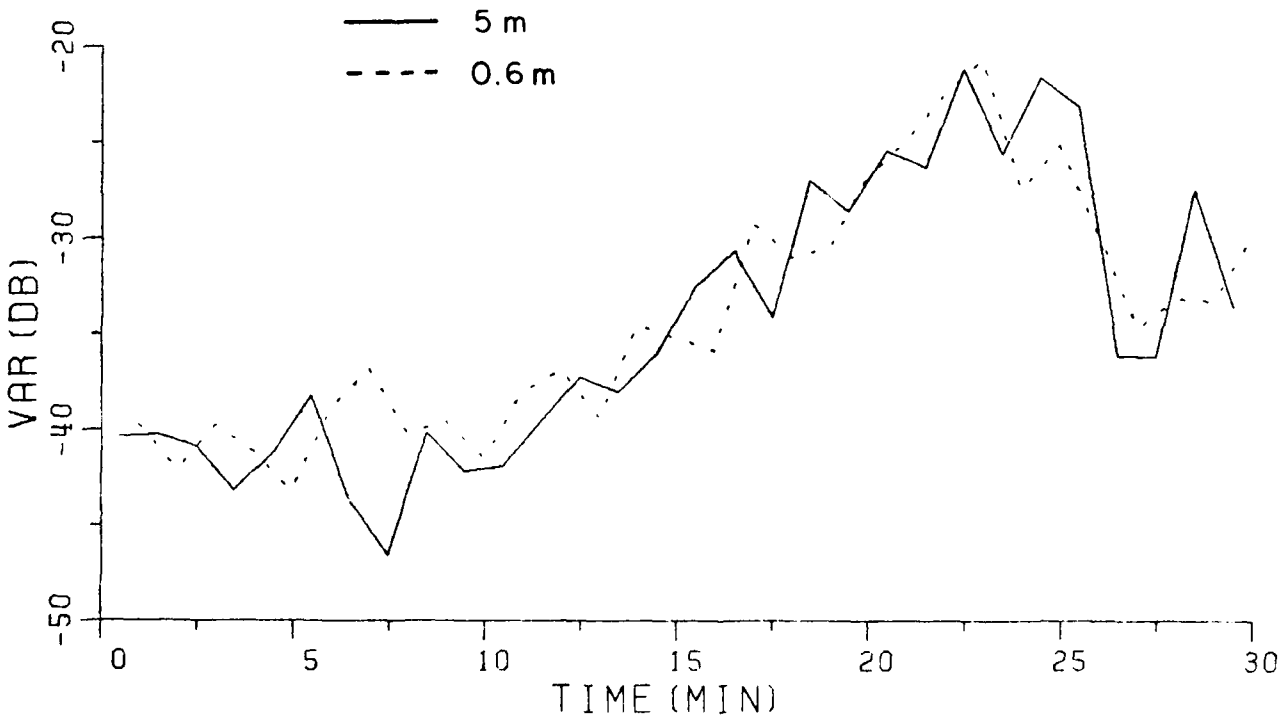
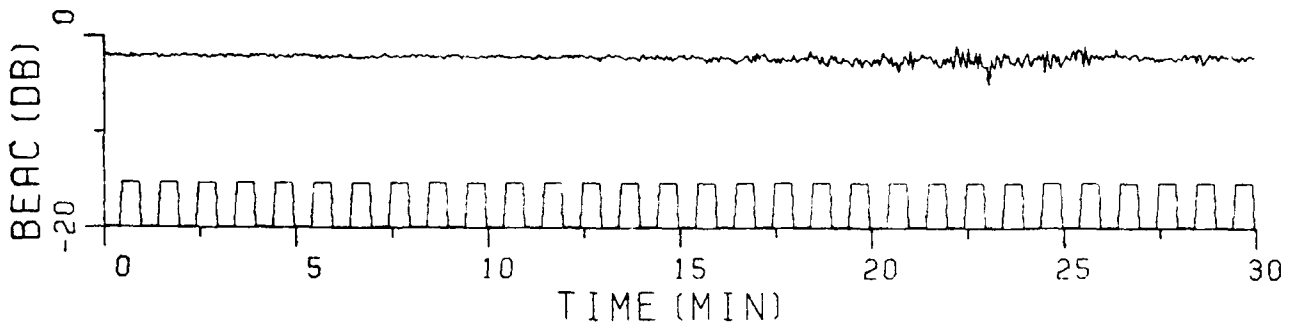

Figure 10. Variance behavior during enhanced clear air scintillation.

DAY 224 HR 1 MIN 59 SEC 14 MSEC 691

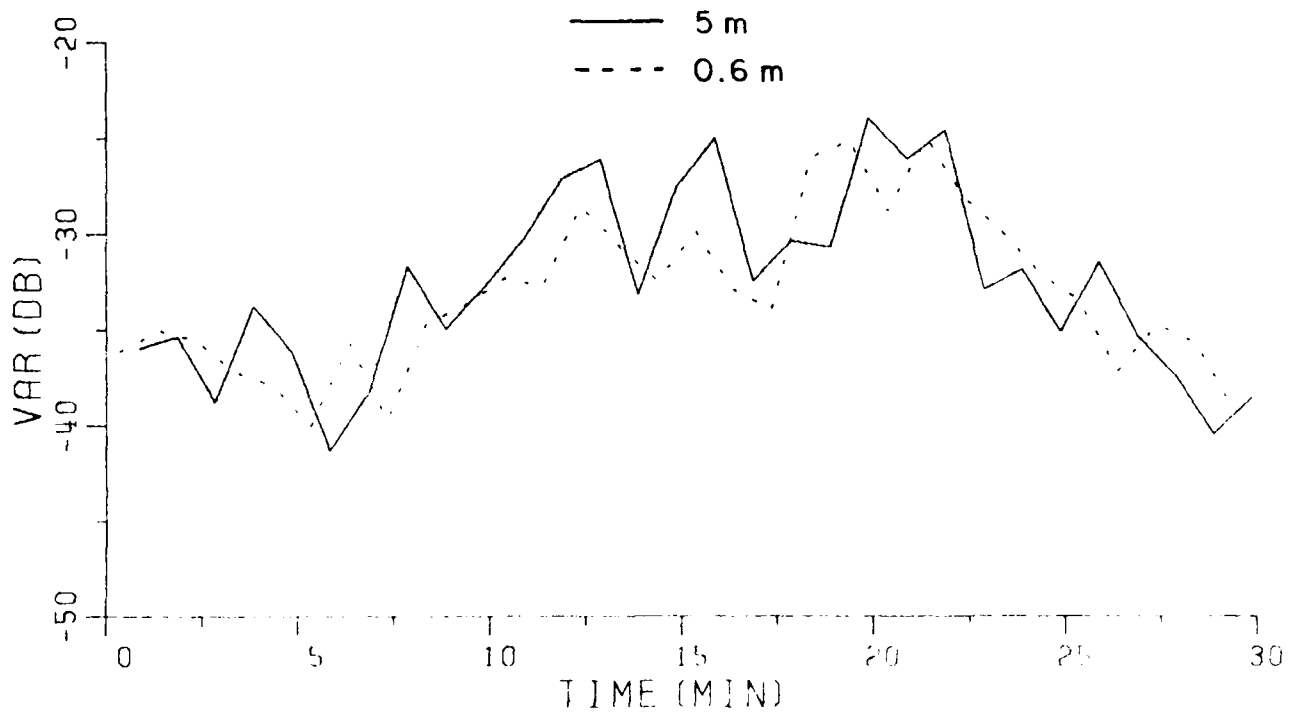
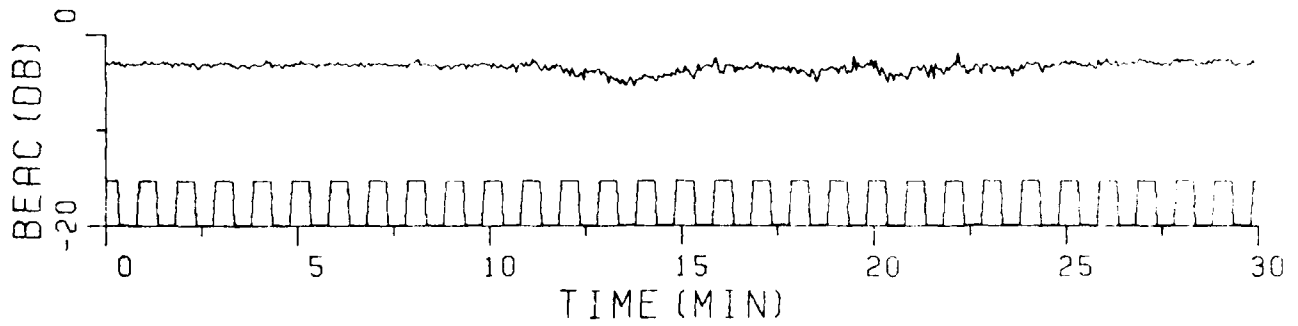

Figure 11. Variance behavior during a shallow precipitation fade event.

fade events. A number of events were observed in which the scintillation level of the larger aperture antenna consistently exceeded that of the smaller antenna during this onset period. Samples of these cases are shown in Figures 12, 13, 14, and 15. The increases in each of these cases were on the order of 5 to 10 dB and lasted for about 5 to 10 minutes. This characteristic was never observed during the period of recovery from a fade event. Similarly, the variance of the smaller antenna was never observed to remain consistently above that of the larger aperture.

At this point, one can only speculate about the physical mechanism leading to this result. A simplistic hypothesis would be to suggest that this effect is related to increased turbulence along the leading edge of a rain cell. This turbulence could, in turn, lead to increased angle of arrival and/or phase front fluctuation. Such an increase would, indeed, have a more dramatic effect on a larger aperture, narrower beam-width antenna. In contrast, a mechanism leading only to amplitude scintillation should be indistinguishable by the two antennas.

Another factor which might contribute to this behavior is the presence of very high humidity in the region just ahead of the leading edge of the rain cell. This would tend to enhance the effect of any turbulence of the electromagnetic wave. Furthermore, it is reasonable to conjecture that the humidity would be considerably higher in the region ahead of the rain cell than in the region behind the cell. Nevertheless, these comments about turbulence and humidity can neither be substantiated nor discounted on the basis of measurements available at the present time.

The behavior noted above was not observed in every case. For example, the two deep fade events shown in Figures 16 and 17 show substantially the same variance behavior for both the large and the small apertures.

### STATISTICS

The cumulative statistics of both the instantaneous signal levels and normalized variances associated with both apertures were generated

DAY 218      HR 20   MIN 2    SEC 41    MSEC 91

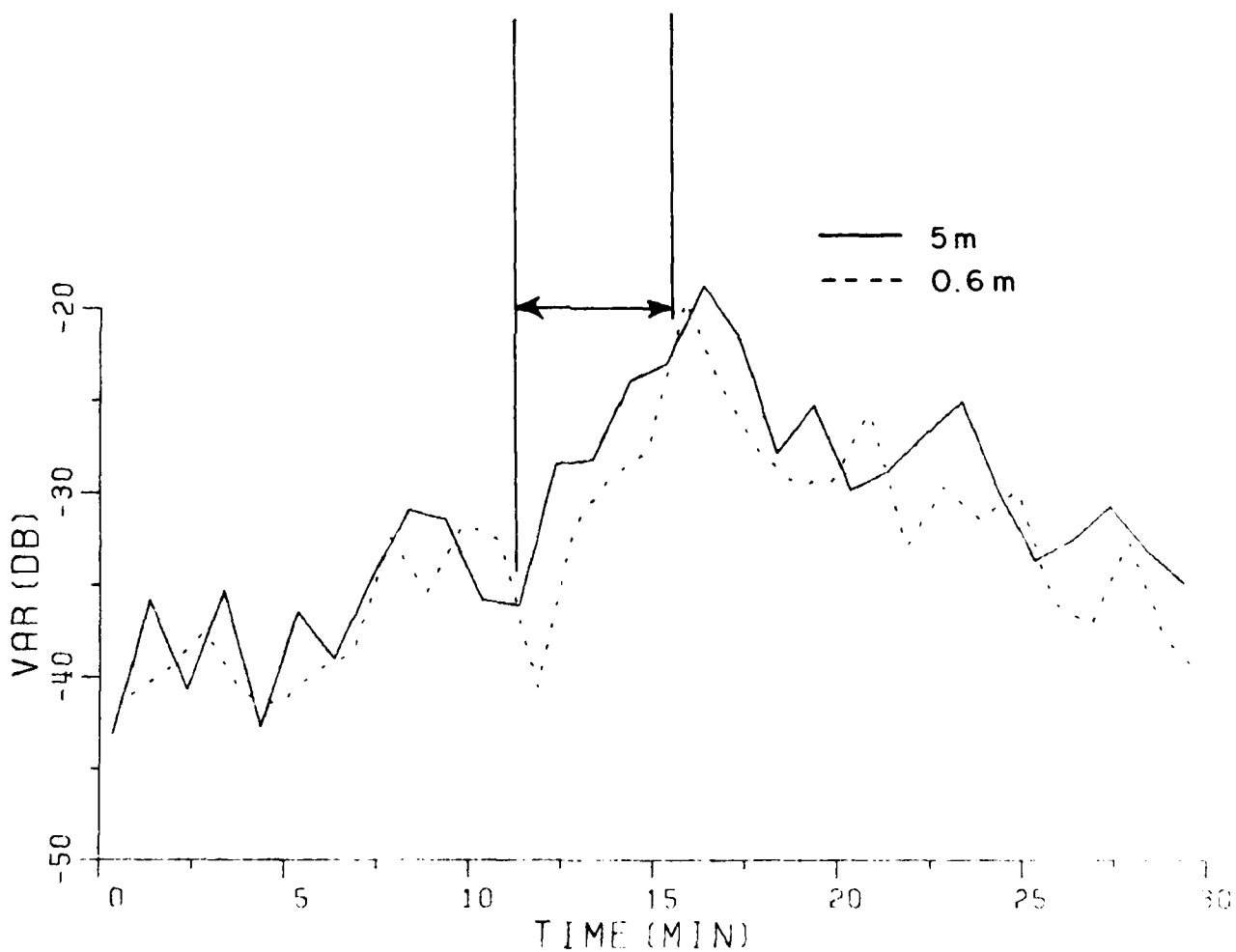
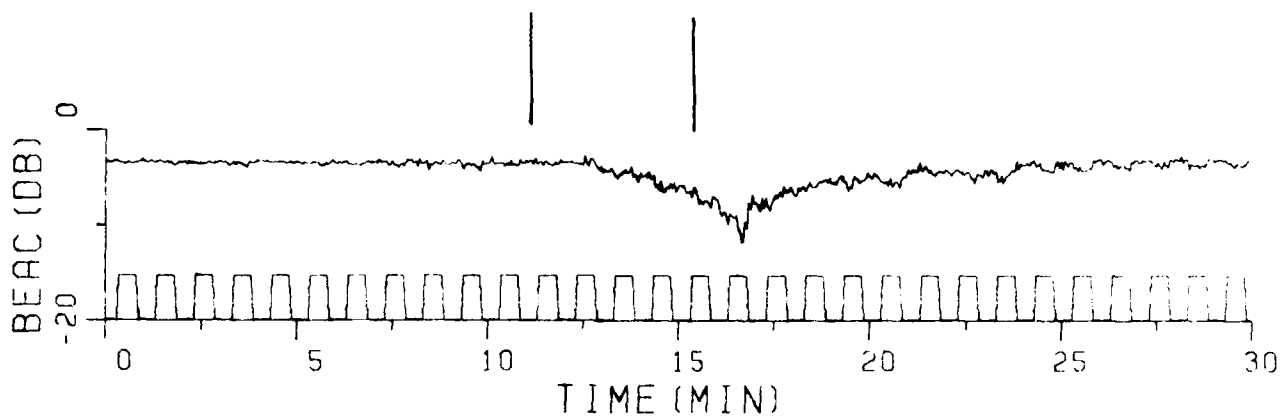

Figure 12. Enhanced large aperture scintillation during onset of precipitation fading.

DAY 218      HR 20 MIN 39 SEC 29      MSFC 91

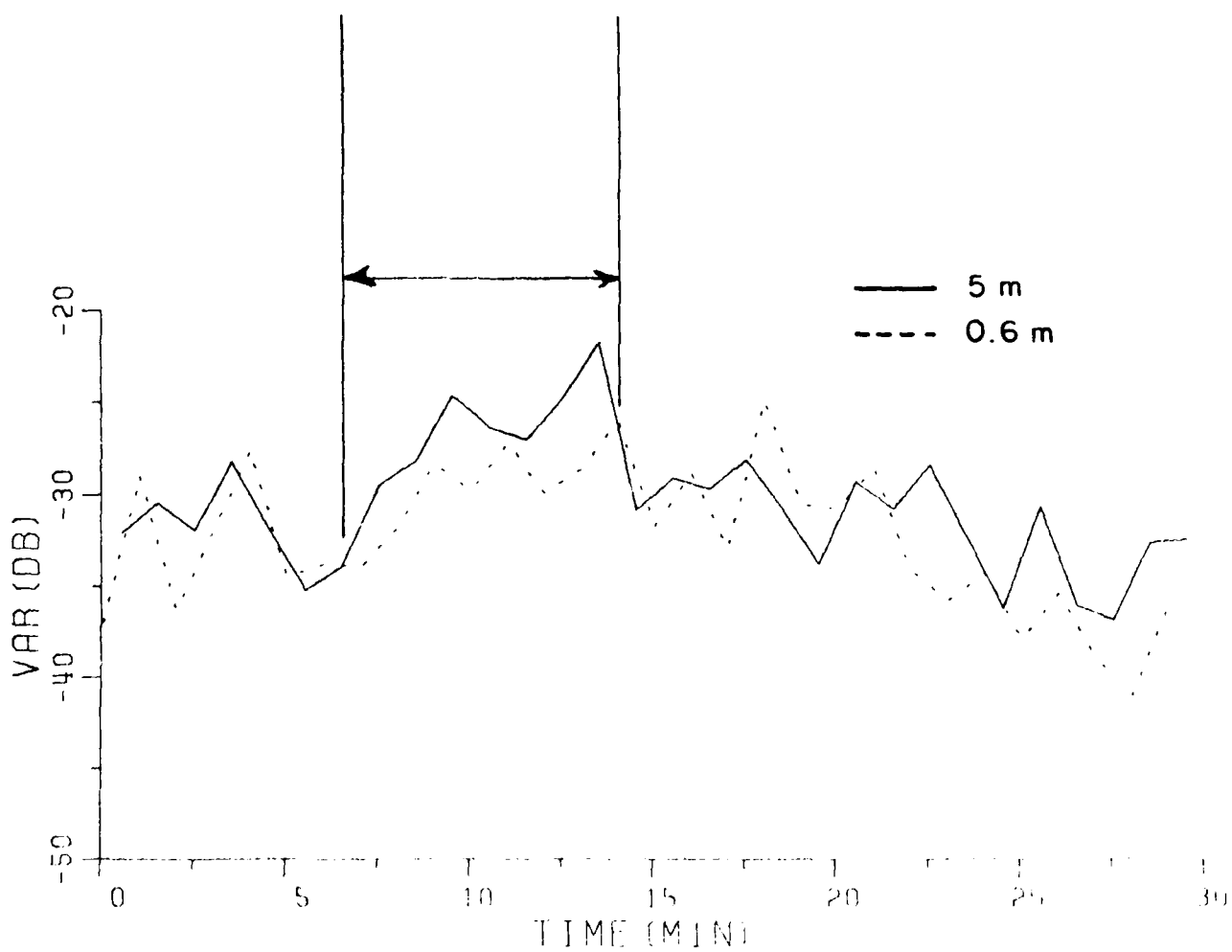
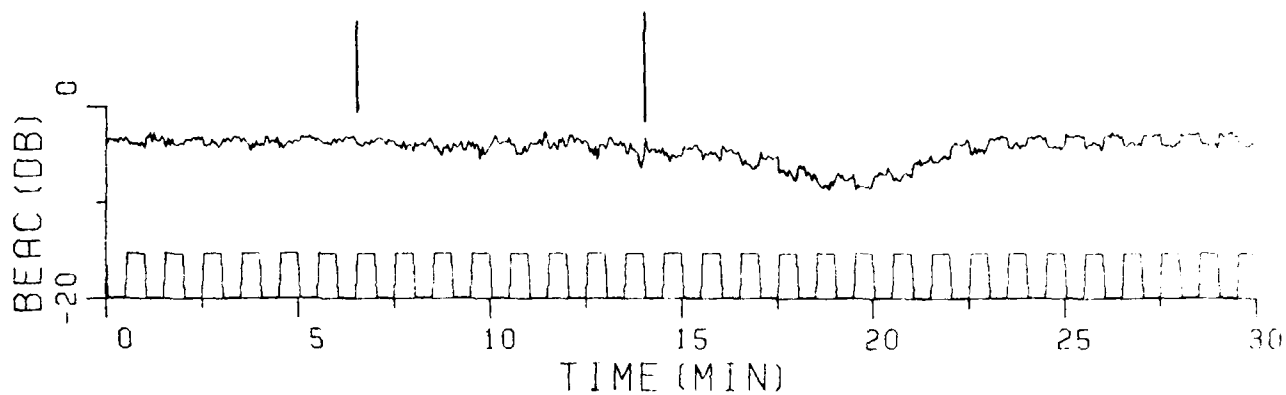

Figure 13. Enhanced large aperture scintillation during onset of precipitation fading.

DAY 224      HR 3    MIN 0    SEC 2    MSEC 691

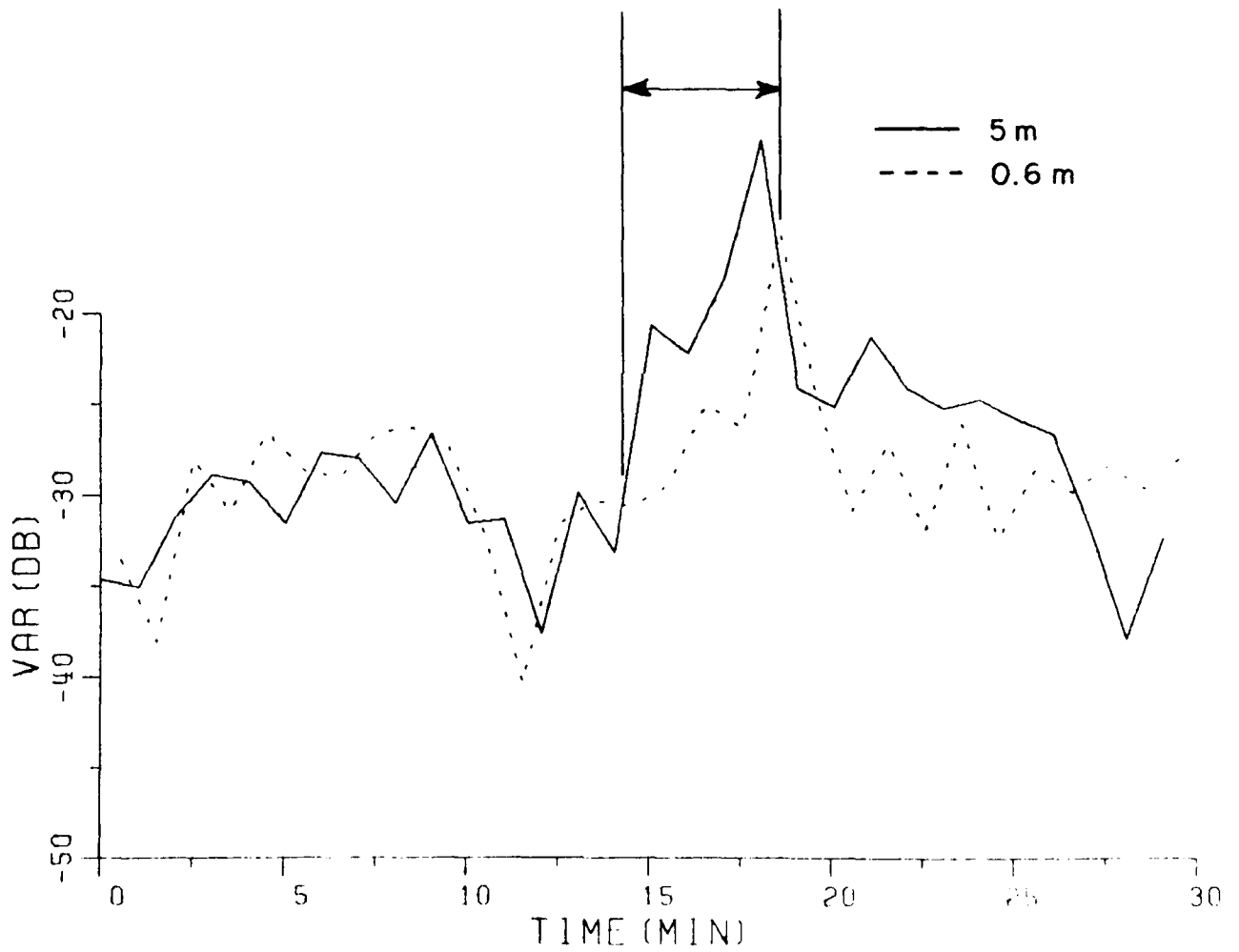
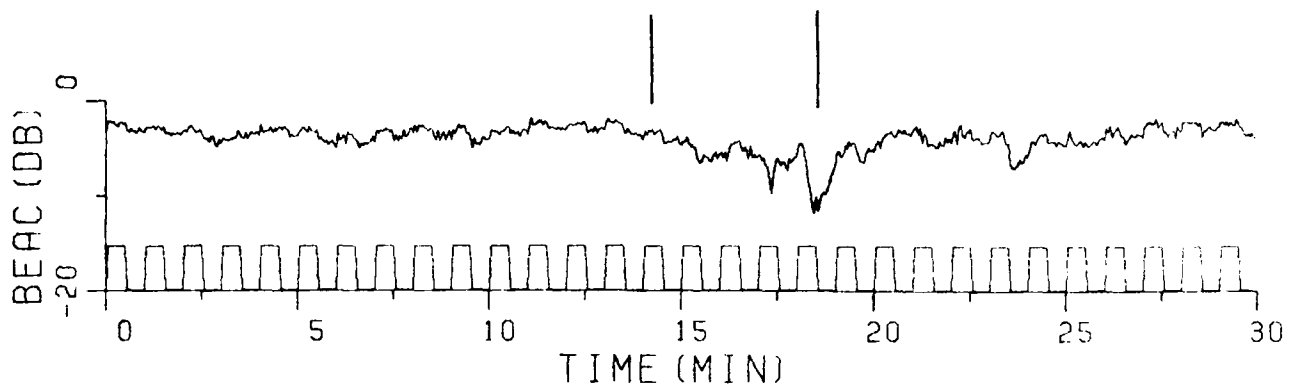

Figure 14. Enhanced large aperture scintillation during onset of precipitation fading.

DAY 233 HR 12 MIN 0 SEC 27

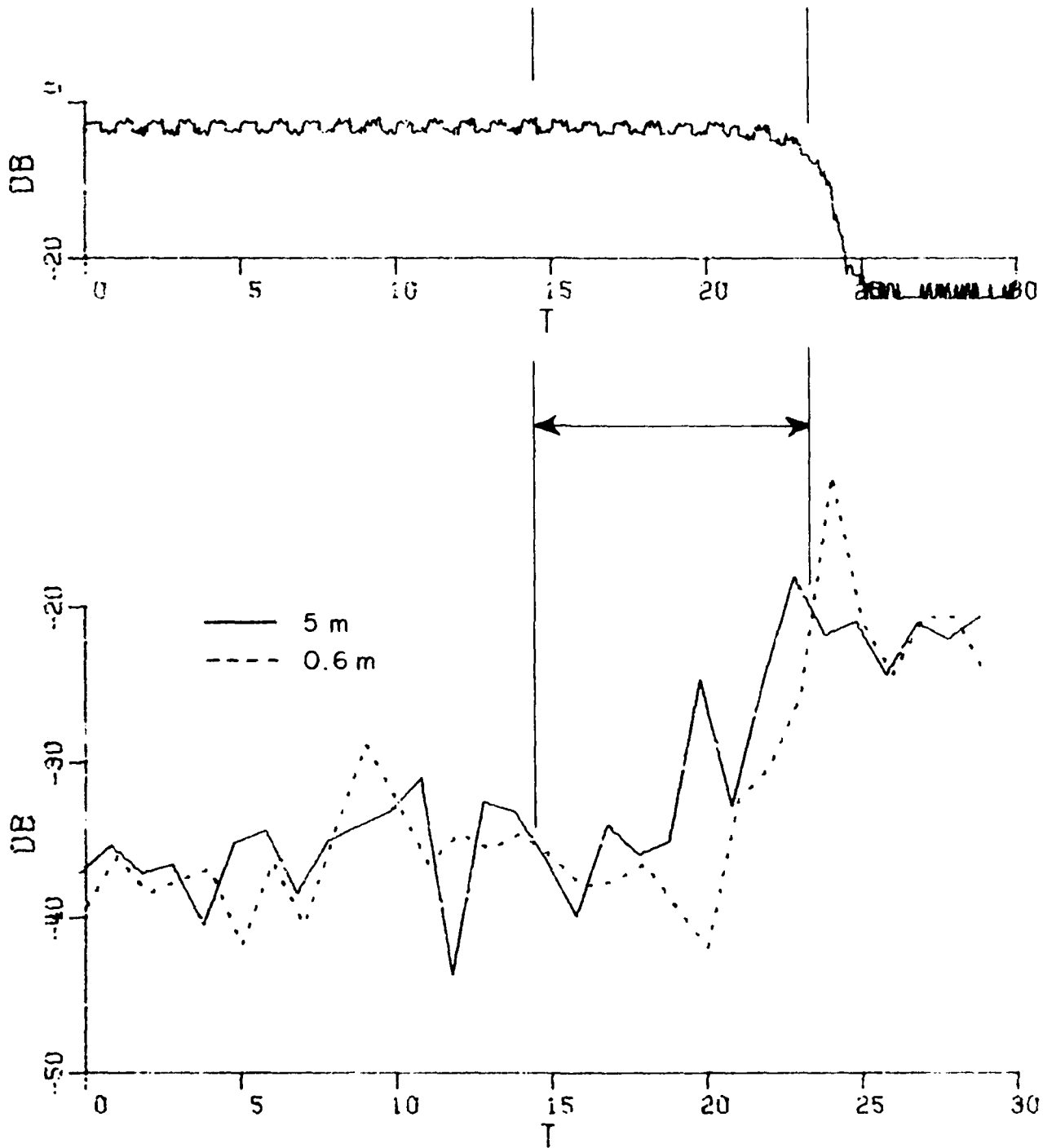

Figure 15. Enhanced large aperture scintillation during onset of precipitation fading.

DAY 231 HR 2 MIN 52 SEC 34 MSEC 994

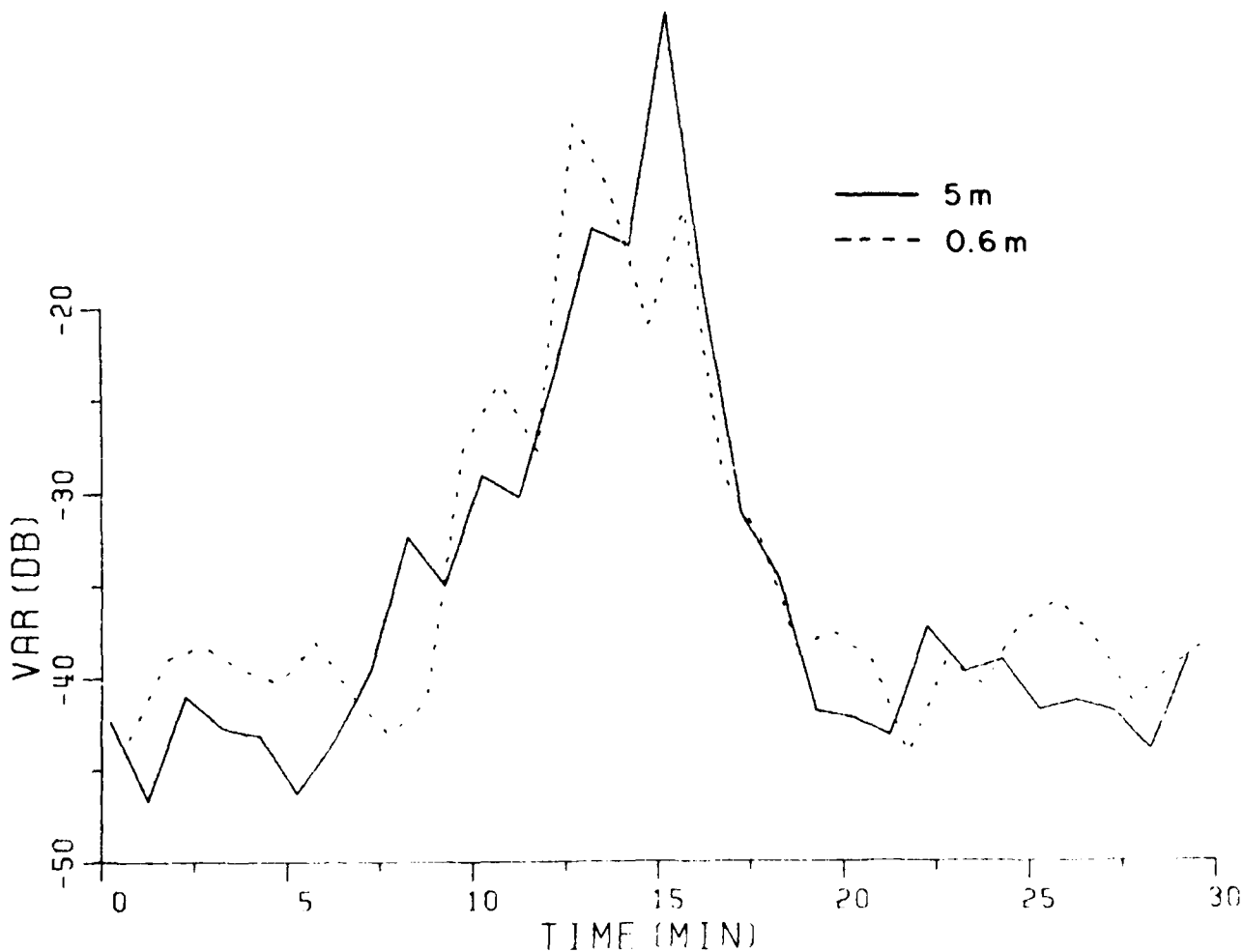
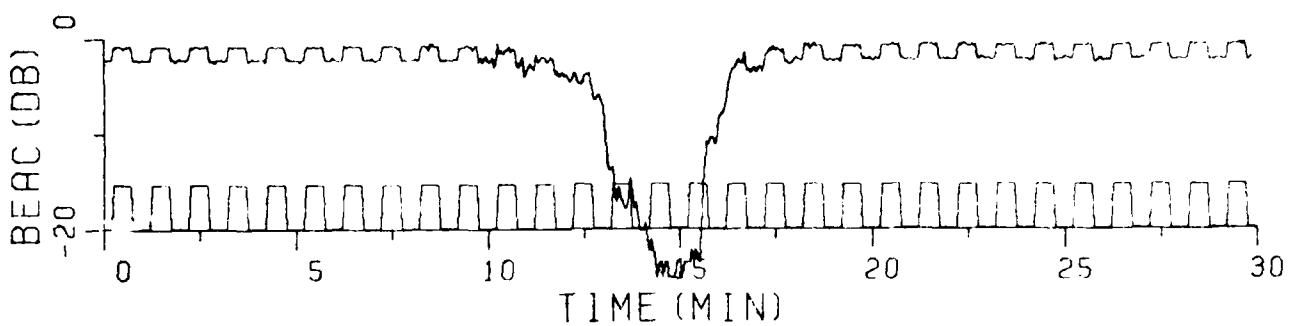

Figure 16. Variance behavior during a precipitation fade event.

DAY 224 HR 5 MIN 31 SEC 17 MSEC 691

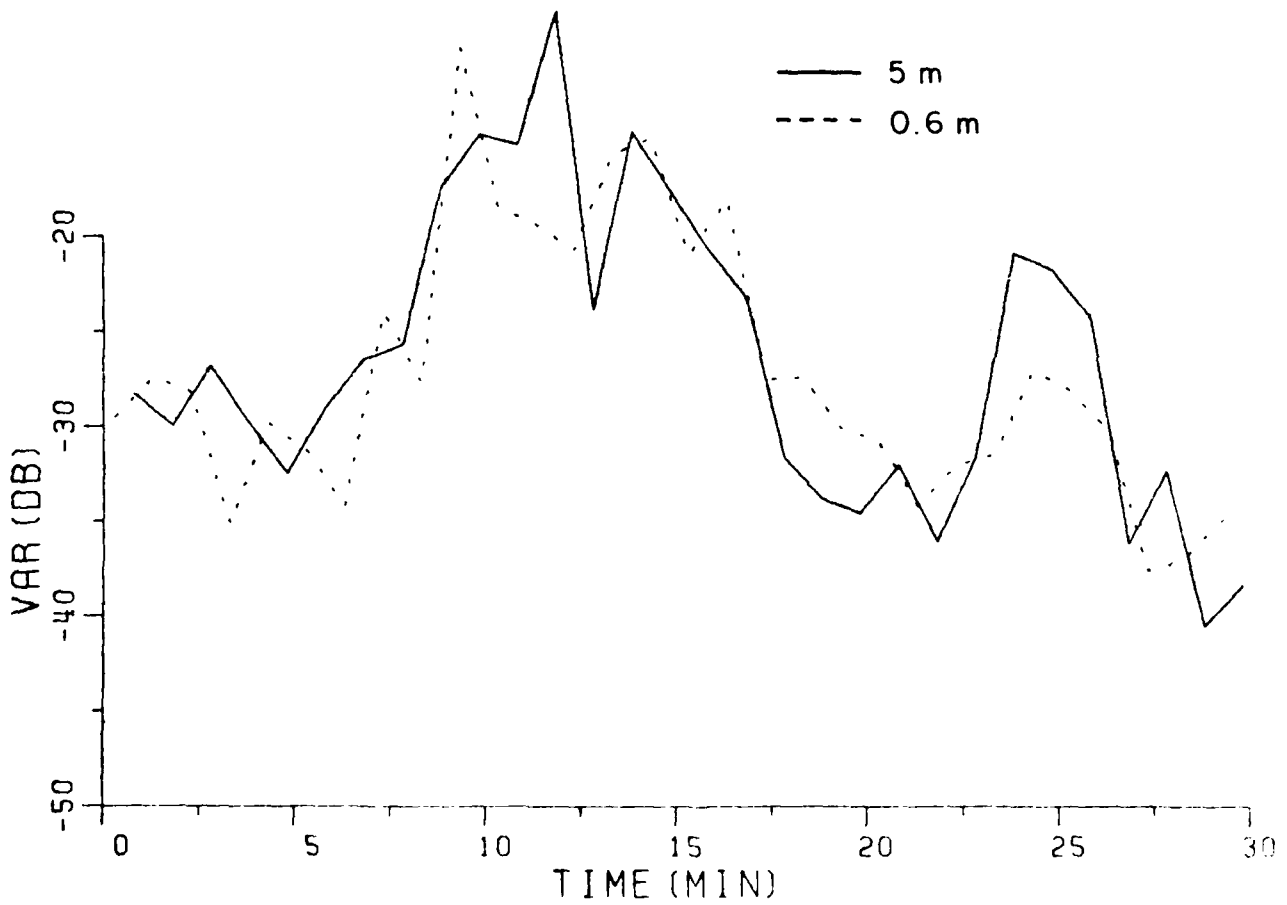
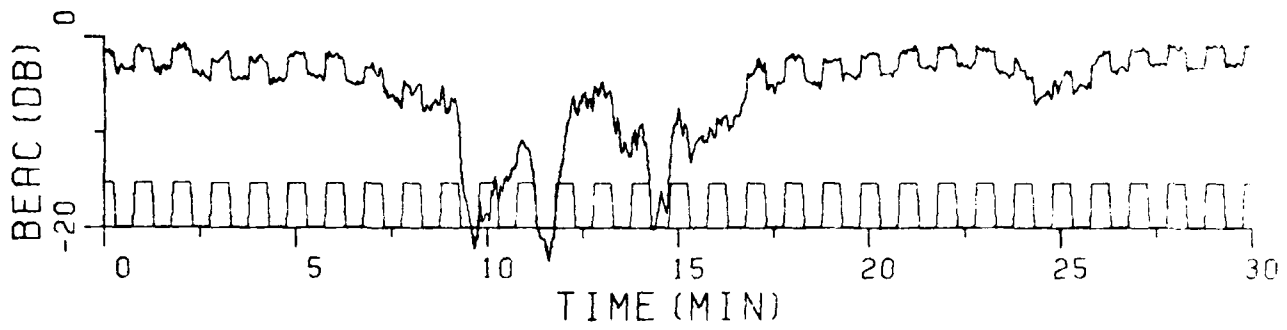

Figure 17. Variance behavior during a precipitation fade event.

for the entire data period. These are shown in Figures 18 and 19.

In the case of the distribution of the received signal level, Figure 18, the results are indistinguishable for fade depths to about 10 dB or percentage times greater than 2%. For greater fade depths the signal level associated with the smaller aperture falls consistently below that for the larger aperture. This result is indeed surprising. One would expect the probability of occurrence of a deep fade to be higher for the larger antenna if angle of arrival fluctuation were the dominant mechanism. The difference in signal level is not large, i.e., it is only about 3 dB; nevertheless, the difference is large enough to be significant. A satisfactory explanation of this result has not been found at the present time.

The distributions of the variances are shown in Figure 19. In this case, it was found that the variance associated with the larger aperture exceeded that of the smaller aperture for almost 50% of the time. This result agrees with the characteristic noted earlier that the large aperture variance was often larger during the onset of precipitation fading. However, the likelihood of this occurrence is much larger than can be associated only with fade events. In addition, in a statistical sense, the differences in variance are only 2 to 3 dB for smaller percentages of time.

The behavior of the variances appears to be consistent with the concept of amplitude fluctuation induced by angle of arrival variation. However, this seems to be inconsistent with the results obtained for the signal level distributions which, as noted earlier, seemed to imply that angle of arrival variation could not be the dominant mechanism.

Obviously, additional measurements and study will be required to clarify these uncertainties. The shut-down of the 28 GHz D/3 beacon was indeed unfortunate for this experiment since the expected sensitivity of the experiment was reduced considerably. The availability of the D/4 28 GHz beacon will permit these problems to be re-examined in greater detail and will, hopefully, allow progress to be made in the understanding

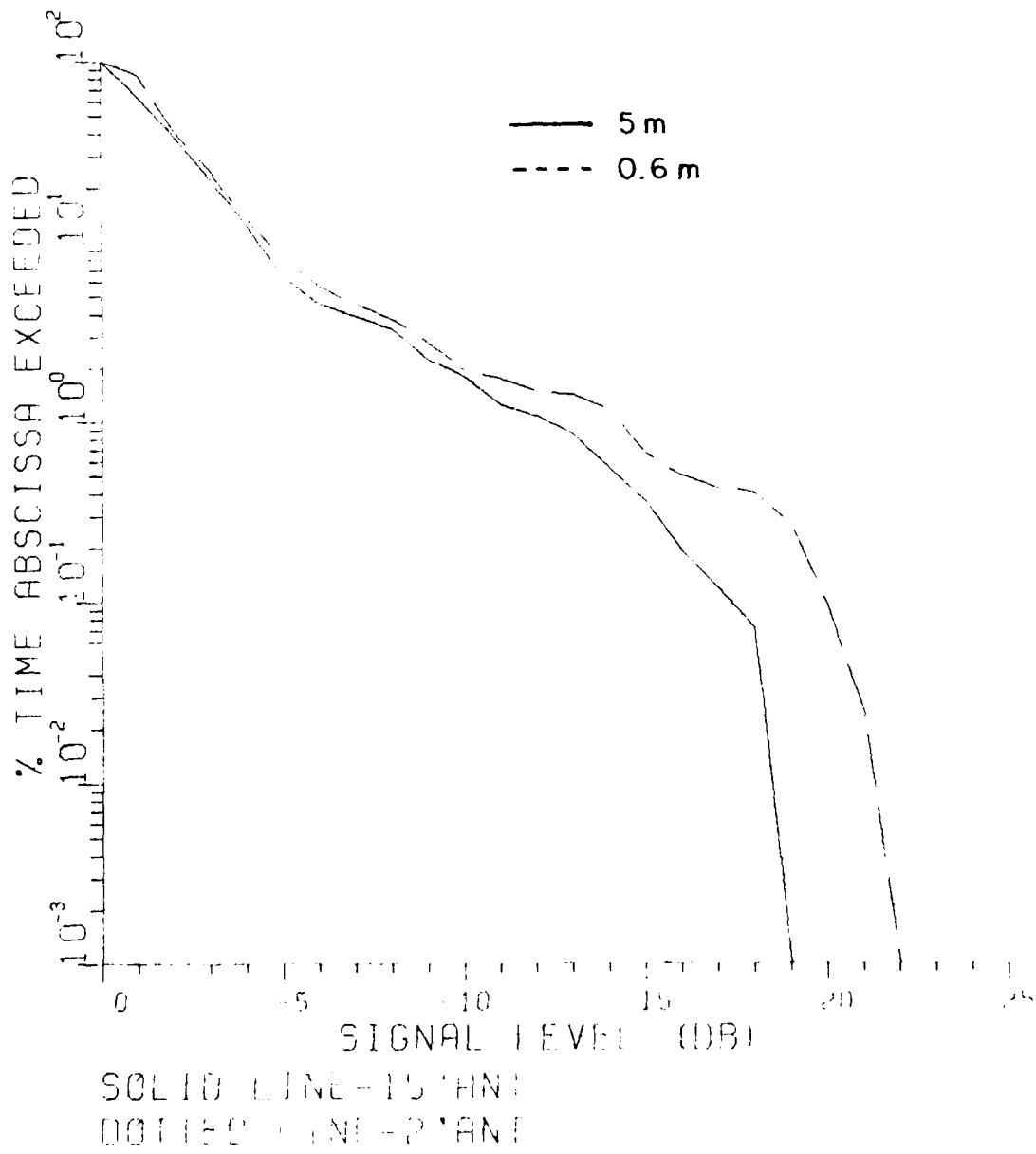

Figure 18. Fade distributions for large and small apertures.

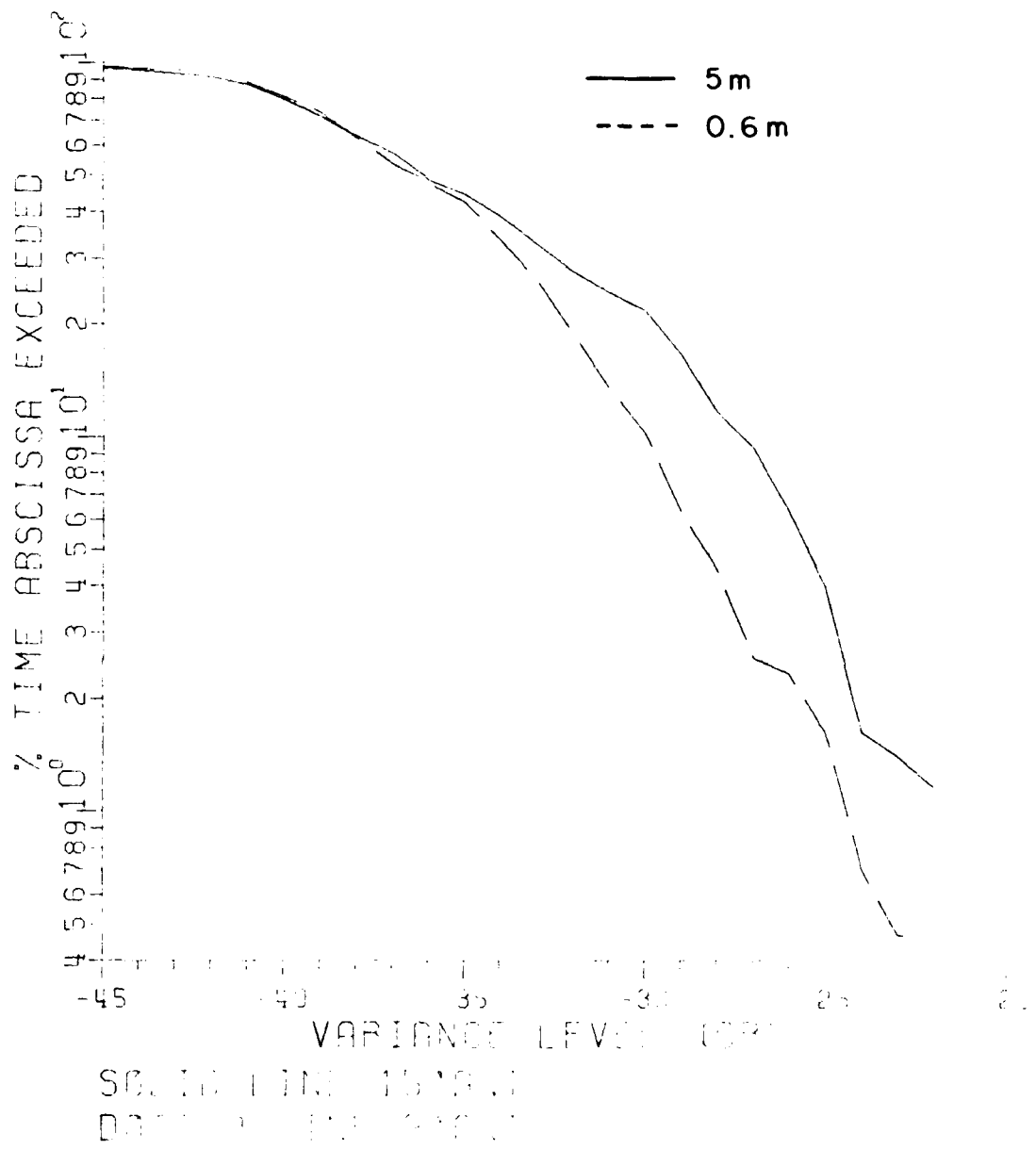

Figure 19. Variance distribution for large and small apertures.

of these phenomena.

#### SUMMARY

The results of 19 GHz gain degradation measurements using the Comstar D/3 beacon have been reported. These measurements compared the received signal levels for 0.6 and 5 m apertures which viewed the same physical and electrical propagation path.

The variance of the signal associated with the larger aperture often exceeded that of the smaller aperture for 5 to 10 minutes prior to the onset of precipitation fading. The difference between the variances under these circumstances was as large as 10 dB. Furthermore, on a statistical basis, the variance associated with the larger aperture tended to be 2 to 3 dB above that of the smaller aperture for rather large percentages of time.

In contrast with the variance behavior, the signal level associated with the larger aperture tended to be about 3 dB higher than that of the smaller antenna for percentage times less than about 2%. This latter result tends to contradict explanations based on angle of arrival fluctuation. Further measurement and study will be required to eliminate this dilemma.

## REFERENCES

- [1] B.W. Kwan and D.B. Hodge, "The CTS 11.7 GHz Angle of Arrival Experiment", Report 712759-2, January 1981, The Ohio State University ElectroScience Laboratory, Department of Electrical Engineering; prepared under Contract NASW-3393 for National Aeronautics and Space Administration Headquarters, Washington, D.C.
- [2] D.M.J. Devasirvatham and D.B. Hodge, "Amplitude and Angle of Arrival Measurements on a 28.56 GHz Earth-Space Path", Report 712759-4, March 1981, The Ohio State University ElectroScience Laboratory, Department of Electrical Engineering; prepared under Contract NASW-3393 for National Aeronautics and Space Administration Headquarters, Washington, D.C.
- [3] C.B. Sun and D.B. Hodge, "Radar Measurements of Rain Cells -- System Configuration, Calibration, and Initial Results," Report 712742-1, April 1981, The Ohio State University ElectroScience Laboratory, Department of Electrical Engineering; prepared under Contract INTEL-066 for International Telecommunications Satellite Organization, Washington, D.C.
- [4] C.B. Sun, "A Study of the Measurement of Rainfall by Combined Use of Radar, Radiometer, and Satellite Beacon Receiver," Report 712742-2, June 1981, The Ohio State University ElectroScience Laboratory, Department of Electrical Engineering; prepared under Contract INTEL-066 for International Telecommunications Satellite Organization, Washington, D.C.
- [5] D.M. Theobald and D.B. Hodge, "ATS-6 Millimeter Wavelength Propagation Experiment," Report 3863-4, April 1975, The Ohio State University ElectroScience Laboratory, Department of Electrical Engineering; prepared under Contract NAS5-21983 for National Aeronautics and Space Administration, Goddard Space Flight Center, Greenbelt, Maryland.