

DUPLICATE COPY

ESL-TR-89-30

1

# RESPONSE OF SEMIHARDENED AIRCRAFT SHELTER FIRE PROTECTION SYSTEM TO BOMB BLAST LOADING

D.M. ZALLEN, J. MARQUIS

NEW MEXICO ENGINEERING RESEARCH INSTITUTE  
UNIVERSITY OF NEW MEXICO  
ALBUQUERQUE NM 87131

FEBRUARY 1990

FINAL REPORT

AUGUST 1987 — MARCH 1989

AD-A230 359

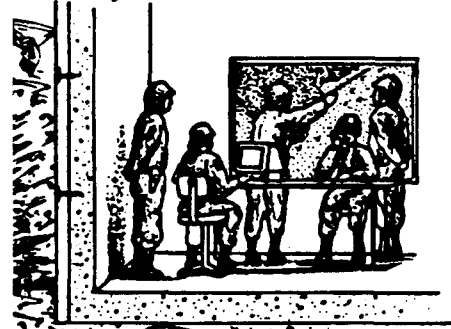
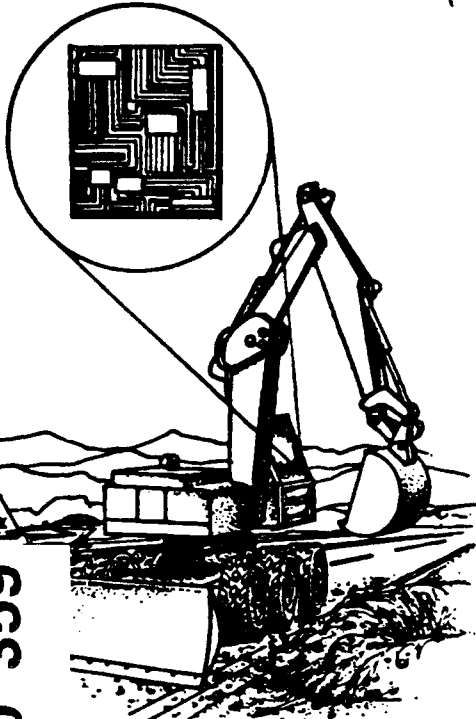

DTIC  
SELECTE  
JAN 02 1991  
S D D

APPROVED FOR PUBLIC RELEASE: DISTRIBUTION UNLIMITED



**ENGINEERING RESEARCH DIVISION**  
Air Force Engineering & Services Center  
ENGINEERING & SERVICES LABORATORY  
Tyndall Air Force Base, Florida 32403



96 0 00 076

NOTICE

PLEASE DO NOT REQUEST COPIES OF THIS REPORT FROM  
HQ AFESC/RD (ENGINEERING AND SERVICES LABORATORY).

ADDITIONAL COPIES MAY BE PURCHASED FROM:

NATIONAL TECHNICAL INFORMATION SERVICE  
5285 PORT ROYAL ROAD  
SPRINGFIELD, VIRGINIA 22161

FEDERAL GOVERNMENT AGENCIES AND THEIR CONTRACTORS  
REGISTERED WITH DEFENSE TECHNICAL INFORMATION CENTER  
SHOULD DIRECT REQUESTS FOR COPIES OF THIS REPORT TO:

DEFENSE TECHNICAL INFORMATION CENTER  
CAMERON STATION  
ALEXANDRIA, VIRGINIA 22314

# REPORT DOCUMENTATION PAGE

Form Approved  
OMB No. 0704-0188

Public reporting burden for this collection of information is estimated to average 1 hour per response, including the time for reviewing instructions, searching existing data sources, gathering and maintaining the data needed, and completing and reviewing the collection of information. Send comments regarding this burden estimate or any other aspect of this collection of information, including suggestions for reducing this burden, to Washington Headquarters Services, Directorate for Information Operations and Reports, 1215 Jefferson Davis Highway, Suite 1204, Arlington, VA 22202-4302, and to the Office of Management and Budget, Paperwork Reduction Project (0704-0188), Washington, DC 20503.

1. AGENCY USE ONLY (Leave blank)		2. REPORT DATE  February 1990	3. REPORT TYPE AND DATES COVERED  Final Report 8/87-3/89	
4. TITLE AND SUBTITLE  RESPONSE OF SEMIHARDENED AIRCRAFT SHELTER FIRE PROTECTION SYSTEM TO BOMB BLAST LOADING			5. FUNDING NUMBERS  C - F29601-84-C-0080 TA - 3.30	
6. AUTHOR(S)  Dennis M. Zallen and John Marquis			8. PERFORMING ORGANIZATION REPORT NUMBER  NMERI WA3-75	
7. PERFORMING ORGANIZATION NAME(S) AND ADDRESS(ES)  New Mexico Engineering Research Institute University of New Mexico Albuquerque, New Mexico 87131			10. SPONSORING/MONITORING AGENCY REPORT NUMBER  ESL-TR-89-30	
9. SPONSORING/MONITORING AGENCY NAME(S) AND ADDRESS(ES)  Engineering and Services Laboratory Air Force Engineering and Services Center Tyndall Air Force Base, Florida 32403			11. SUPPLEMENTARY NOTES	
12a. DISTRIBUTION/AVAILABILITY STATEMENT  Approved For Public Release. Distribution Unlimited.			12b. DISTRIBUTION CODE	
13. ABSTRACT (Maximum 200 words)  Standard specifications for mounting the Hardened Aircraft Shelter Fire Protection System (HAS-FPS) are not sufficient because of the wartime threat to the facilities. Therefore, representative sections of the HAS-FPS, previously tested against actual fire threats, were installed in a full-scale HAS and tested against the blast threats. Data collected with accelerometers and strain gages on equipment were used with wall measurements to analyze the response of various mount concepts. Shock spectra and raw data were formulated into specifications, that can be used in the performance specifications for HAS-FPS and other equipment of similar capacities and locations.				
14. SUBJECT TERMS  Hardened Aircraft Shelter (HAS) Fire Protection System (FPS) Blast and Shock			15. NUMBER OF PAGES  71	
17. SECURITY CLASSIFICATION OF REPORT  UNCLASSIFIED			16. PRICE CODE	
18. SECURITY CLASSIFICATION OF THIS PAGE  UNCLASSIFIED		19. SECURITY CLASSIFICATION OF ABSTRACT  UNCLASSIFIED		20. LIMITATION OF ABSTRACT

## EXECUTIVE SUMMARY

- A. **OBJECTIVE:** The objective of this work was to develop shock/vibration criteria for securely mounting a fire protection system inside a semihardened aircraft shelter.
- B. **BACKGROUND:** The Hardened Aircraft Shelter Fire Protection System (HAS-FPS) had been previously tested to provide rapid, clean fire protection. The HAS-FPS will be suspended inside semihardened shelters in order to mitigate interference with other operations. A potential blast environment exists due to the wartime threat. It was necessary to develop specification criteria for securely mounting the system components to ensure their reliability for performance. Existing specifications only consider normal or peacetime environments for shock and vibration.
- C. **SCOPE:** The scope of this effort was to install the prototype systems in an actual semihardened shelter and expose the shelter and its contents to the actual blast threat environment. Empirical data would be collected and analyzed to form performance data needed for specification.
- D. **METHODOLOGY:** Theoretical predictions are unduly complex and not sufficiently accurate for obtaining the responses of the HAS-FPS for the unique application (HAS) environment and configuration (suspended inside). Therefore, it was necessary to obtain empirical data to guide the performance specification of system components and assemblies.
- E. **TEST DESCRIPTION:** The prototype HAS-FPS assemblies were installed in a full-scale semihardened aircraft shelter located at the Utah Test and Training Range. The shelter was then subjected to the blast threats. Accelerometer, strain gage, video and high speed motion picture measurements were taken. The response characteristics of the gages used in the test series, the approach taken in selecting the filtering and sampling rates, the procedures and techniques used to correct data, and a detailed analysis of the quality of the raw and corrected data are presented.
- F. **RESULTS:** All HAS-FPS equipment survived the shock effects introduced by the detonation of the conventional weapon in each aircraft shelter test. The use of chemical bolts for mounting heavy bottles containing extinguishing agent and welding of lightweight assemblies to the shelter inner metal liner proved sufficient since no structural, mechanical, or electrical failures were noticed upon posttest inspection of the equipment.
- G. **CONCLUSIONS:** The required shock response spectrum for the HAS-FPS equipment to be mounted on the arch wall is specified. The required spectrum applies to both the vertical and

horizontal axes of the equipment as defined by the mounted configuration in the aircraft shelter. The equipment shock qualification procedures by testing are described.

H. RECOMMENDATIONS: The required shock response spectrum and the mounting techniques from this study can be used as specifications in the acquisition of the HAS-FPS.

PREFACE

This report was prepared by the New Mexico Engineering Research Institute (NMERI), University of New Mexico (UNM), Albuquerque, New Mexico 87131 under Contract Number F29601-84-C-0080 (Subtask Statement No. 3.30) for the Air Force Engineering and Services Center (HQ AFESC/RDCF), Tyndall Air Force Base, Florida 32403.

This report summarizes the work done between August 1987 to March 1989. The HQ AFESC/RDCF Program Manager was Joseph L. Walker.

English units are used since they are in reference to the drawings and equipment from commercial companies that provided those units and thereby consistency and relationship are maintained.

This report has been reviewed by the Public Affairs (PA) and is releasable to the National Technical Information Service (NTIS). At NTIS it will be available to the general public, including foreign nationals.

This technical report has been reviewed and is approved for publication.

  
RICHARD N. VICKERS  
Chief, Fire Technology Branch

  
RICHARD M. HANES, Col, USAF  
Director, Engineering and Services  
Laboratory

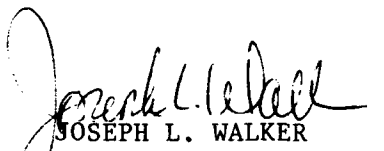
  
JOSEPH L. WALKER  
Chief, Engineering Research  
Division

Accession For	
NTIS CRA&I	<input checked="" type="checkbox"/>
DTIC TAB	<input type="checkbox"/>
Unannounced	<input type="checkbox"/>
Justification	
By	
Distribution /	
Availability Codes	
DIT	Avail and/or Special
A-1	



## TABLE OF CONTENTS

Section	Title	Page
I	INTRODUCTION .....	1
	A. OBJECTIVE .....	1
	B. BACKGROUND.....	1
	C. PROGRAM RELATIONSHIP .....	2
	D. PROJECT RELATIONSHIP .....	2
	E. TECHNICAL APPROACH.....	3
	F. TEST SCHEDULE.....	10
II	MOUNTING HARDWARE.....	11
	A. INTRODUCTION.....	11
	B. SUBSYSTEM CONFIGURATIONS .....	11
	1. Company 'A'.....	11
	2. Company 'C'.....	12
	C. DESCRIPTION OF COMPANY 'A' MOUNTING HARDWARE.....	12
	1. Construction Package for Company 'A' Mounting Hardware .....	12
	D. DESCRIPTION OF COMPANY 'C' MOUNTING HARDWARE.....	22
	1. Design Philosophy.....	22
	2. Construction Package for Company 'C' Mounting Hardware .....	23
III	TEST ARTICLES.....	34
IV	EQUIPMENT LOCATIONS .....	40
	A. AS-BUILT HARDWARE GENERAL LOCATIONS .....	40
	B. HARDWARE MOUNTINGS/LOCATIONS FOR FIRST TEST EVENT .....	40
	C. HARDWARE MOUNTINGS/LOCATIONS FOR SUCCESSIVE TEST EVENTS.....	42
V	GAGE INFORMATION .....	44
	A. INSTRUMENTATION PLAN .....	44
	B. DESCRIPTION OF TEST INSTRUMENTATION .....	44
VI	HAS-FPS SHOCK TEST SPECIFICATION .....	61
	A. INTRODUCTION.....	61
	B. HAS-FPS EQUIPMENT TEST SPECIFICATION .....	62
	1. Environment for Test Specification.....	62
	2. Equipment Shock Qualification Procedures .....	64

TABLE OF CONTENTS (Concluded)

Section	Title	Page
VII	CONCLUSION .....	66
	REFERENCES.....	67

## LIST OF FIGURES

Figure	Title	Page
1	Schematic of the Semihardened Aircraft Shelter Test Facility.....	4
2	Test Facility. ....	5
3	Test Event. ....	6
4	Simulated Weights Inside Shelter.....	7
5	Mock Aircraft Inside Shelter. ....	8
6	Mock Fuel Tank and Weapons Inside Shelter.....	9
7	Company 'A' Cylinder/Header/Manifold Assembly. ....	13
8	Company 'A' Tray Cylinder Support. ....	14
9	Company 'A' Tray Construction. ....	15
10	Company 'A' Suspension Cylinder Mount.....	16
11	Company 'A' Cylinder Suspension Assembly.....	17
12	Company 'A' Detector Bracket. ....	18
13	Company 'A' Agent Manifold. ....	20
14	Company 'A' Fire Control Module.....	21
15	Company 'C' Bracket for Tyndall Air Force Base. ....	24
16	Company 'C' Bracket for Tyndall Air Force Base. ....	25
17	Company 'C' Bracket for Tyndall Air Force Base. ....	26
18	Company 'C' Cylinder Assembly with Shock Mount. ....	27
19	Company 'C' Cylinder Assembly with Shock Mount. ....	28
20	Company 'C' Cylinder Assembly without Shock Mount.....	30
21	Company 'C' Cylinder Assembly without Shock Mount.....	31
22	Company 'C' Detector Bracket. ....	32
23	Tray and Detector Mounts for Company 'A' Hardware. ....	35
24	Suspension Mount for Company 'A' Cylinder. ....	36

LIST OF FIGURES (Concluded)

Figure	Title	Page
25	Hard Mount for Company 'C' Cylinder.....	37
26	Antivibration Mount for Company 'C' Cylinder.....	38
27	Control Module and Detector Mounts for Company 'C' Hardware. ....	39
28	Pseudovelocity Shock-Response Spectrum for HAS-FPS Equipment, 5 Percent Damped.....	63

## LIST OF TABLES

Table	Title	Page
1	SCHEDULE OF TEST EVENTS.....	10
2	INSTRUMENTATION SUMMARY.....	45
3	INSTRUMENTATION DESCRIPTION FROM TEST PLAN.....	46
4	INSTRUMENTATION MEASUREMENT NUMBERS FROM TEST PLAN.....	47
5	MEASUREMENT LIST AS BUILT FOR TEST 1.....	48
6	INSTRUMENTATION FOR TEST 2.....	52
7	AS-BUILT INSTRUMENTATION FOR TEST 2.....	53
8	INSTRUMENTATION FOR TEST 3.....	54
9	AS-BUILT GAGE LOCATIONS FOR TEST 3.....	55
10	AS-BUILT GAGE IDENTIFICATION FOR TEST 3.....	57
11	INSTRUMENTATION FOR TEST 4.....	58
12	AS-BUILT GAGE IDENTIFICATION FOR TEST 4.....	59
13	AS-BUILT GAGE LOCATIONS FOR TEST 4.....	60

## SECTION I INTRODUCTION

### A. OBJECTIVE

The objective of this effort was to collect blast response data and produce applicable specifications for mounting the Hardened Aircraft Shelter Fire Protection System (HAS-FPS) (Reference 1) into the intended facilities. This technical data requirement was needed because of the potential blast environment of the wartime threat.

Existing military standards, which include test methods, generally consider normal or peacetime environments. For example, the vibration and shock tests required under MIL-STD 810, entitled *Environmental Test Methods* (Reference 2), are typical for equipment being carried, launched, or dropped and are atypical for equipment being crashed or blasted. Other specification-type data were neither available nor sufficiently accurate because of the type of facility, the location of the fire protection system components, the degree of conformity of the calculational models, and the specific blast threat. Consequently, the empirical formulation of performance requirements in the potential environment was necessary in order to ensure the reliability of the HAS-FPS.

### B. BACKGROUND

The research prototype HAS-FPS was successfully tested for fire protection goals and the system fire-performance description has been prepared. To place the HAS-FPS successfully into the field, the appropriate building and design codes must be implemented. Because of the particular environment of application, standard codes and practices will not be sufficient for all the subsystems. In particular, the responses of the HAS-FPS and other similar installed items to bomb blast and aircraft operations are not well defined for the particular facility (HAS) and hardware (FPS). Because theoretical predictions are unduly complex, it is necessary to obtain empirical data to design system components and assemblies that meet performance and reliability criteria. In summary, the unique application (HAS environment) and configuration (suspended inside) of the HAS-FPS requires conformance with USAF design data that is not common to commercial industry. For example, shock and vibration specifications for the durability and safety of mountings for cylinders, detectors, piping, and controls needed to be defined to ensure the design and mission performances of the FPS and other potential installed subsystems.

### C. PROGRAM RELATIONSHIP

The application of rapid, automatic, and reliable fire protection provides readiness by ensuring that the aircraft weapons system is not damaged during a peacetime or wartime fuel spill incident. Such an application also enhances sortie generation by providing a safety system. To ensure proper functioning, a "systems" approach was used for the fire protection system whereby high reliability could be obtained and quantified. Furthermore, to ensure accurate acquisition it is necessary to have detailed applications data for the performance specifications. The development of such data is the basis for this project. These data will assist in defining the requirements for high Mean Time Between Failure (MTBF) and in ensuring that the fire protection system can withstand a wartime environment without causing interference with operations and sortie generation.

### D. PROJECT RELATIONSHIP

This project (Reference 3) was performed in conjunction with the program (Reference 4) for semihardened construction in aircraft shelter upgrades as specifically identified in PMD 4021(6), June 1985, (S), Air Base Survivability. Supporting documentation is included in the "Draft Statement of Need for Passive Air Base Defense and Recovery," USAF SON 319-85, 28 March 1985. The need is also addressed in TAC Draft Requirements Amplification Document, "Transportable Shelters and Physical Protection Upgrade," dated 27 Oct 1986. The specific requirement for the HAS-FPS is presented in the "Air Force Inspection and Safety Center Statement of Operational Need," AFISC SON 1-81.

Recent tests performed by various organizations throughout the Department of Defense indicate that the synergistic effects of a number of weapon types may cause severe impact to an aircraft shelter and its contents. With the exception of the Concrete Sky test series (1967-1975) and the German Aircraft Shelter tests (1983), limited testing of the capability of aircraft shelters to resist conventional weapons effects has been conducted. Thus, a study and validation of vulnerability and upgrade concepts should be undertaken.

Background work performed at the Air Force Weapons Laboratory (AFWL) to support the attack scenarios for Exercise Salty Demo indicated that aircraft shelters would be subjected to serious weapon loadings in a conventional airbase attack. Thus, there is a need to review the vulnerability of the existing aircraft shelters and their contents and then develop and implement ways to reduce that vulnerability.

Existing shelters were designed for the NATO threat criteria developed in 1971. While threat weapon type, accuracy, fusing, etc., have changed significantly in the past 18 years, the design criteria have not been updated. The design of current Third Generation aircraft shelters provides an unbalanced level of survivability for different portions of the structure. The design should be modified to yield a more balanced level of survivability for the entire shelter.

Current siting criteria for shelters were primarily based on the results of the Distant Runner events of the late 1970s. The conclusions drawn from those tests may be overly conservative when more realistic factors are considered, e.g., finite time delays between sympathetic detonations, probability of the occurrence of sympathetic detonations, etc.

Theater aircraft shelters have been modified after facility construction by the addition of internal equipment (e.g., aircraft winch, fuel tanks, racks, fans, personnel house, etc.). Most, if not all, of this equipment has been mounted to the structure without any consideration of shock isolation.

The plan for mounting the HAS-FPS is to attach the components to the internal wall of the various types of shelters (TAB VEE or First Generation, Modified TAB VEE, Second Generation, and Third Generation, in addition to other but similar NATO shelters). When a shelter is hit by the blast of a conventional weapon, pieces of equipment may become internal projectiles and damage the asset the shelter was designed to protect. Consequently, consideration should be given to both mounting the HAS-FPS to support operability and to maintaining the interactive relationship between the structure and its contents.

#### E. TECHNICAL APPROACH

The actual, full-scale fire suppression equipment that was used for fire testing in the HAS-FPS Program (Reference 1) was available for this project. The test facility was a full-scale Third Generation Aircraft Shelter (TGAS). The TGAS was located at Utah Test and Training Range (UTTR) and was constructed (References 4 and 5) to support the Aircraft Shelter Upgrades Program (Reference 6). The test facility is shown isometrically in Figure 1 and photographically in Figure 2. Inventory bombs were used to effect the threat (classified), and a test event is shown in Figure 3.

Interior floor equipment was simulated for the first two test events by weights placed on the floor to represent an aircraft (Figure 4). Mockups of the interior equipment were constructed for the next test events (Figures 5 and 6).

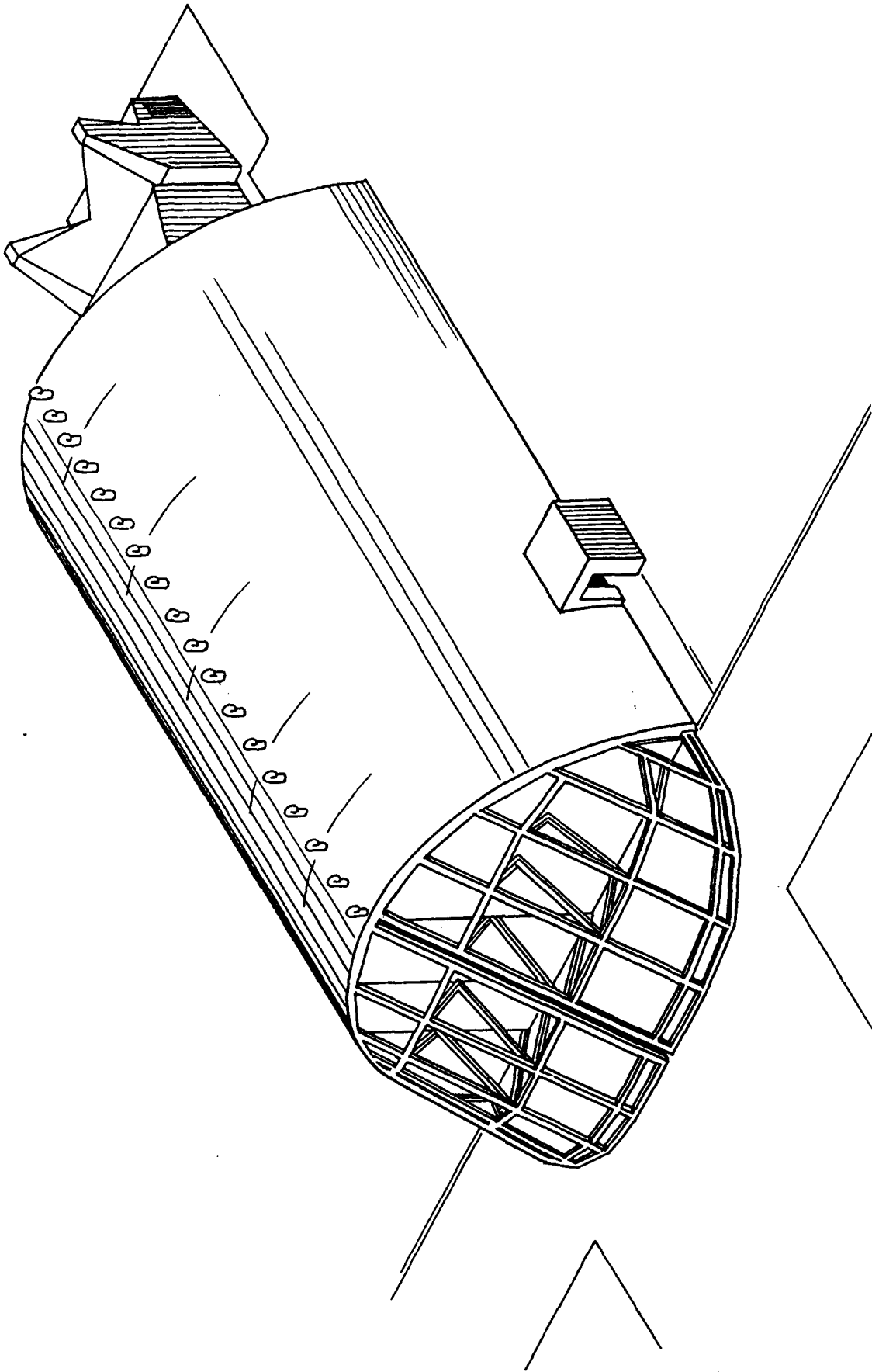

Figure 1. Schematic of the Semi-hardened Aircraft Shelter Test Facility.

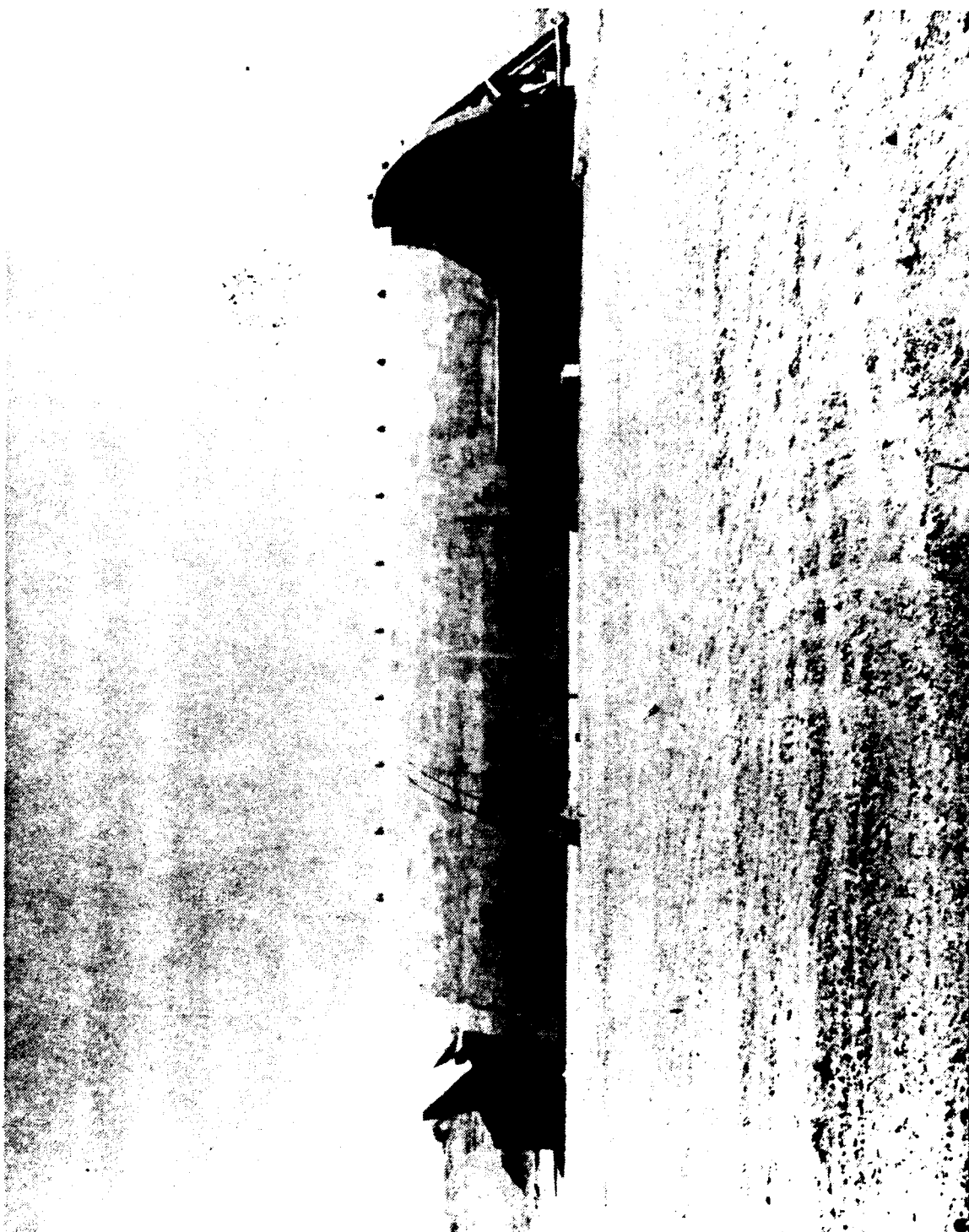

Figure 2. Test Facility.



Figure 3. Test Event.

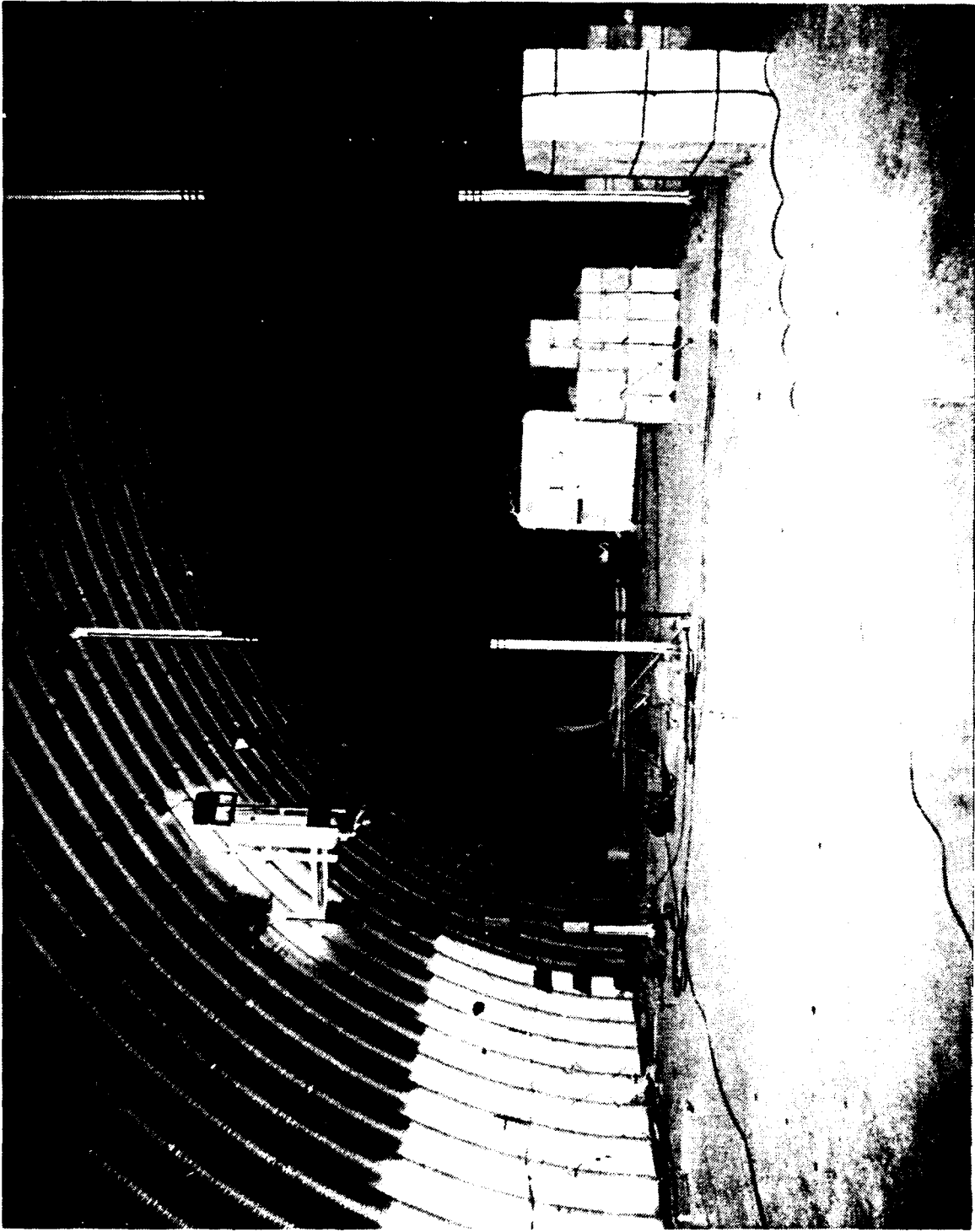

Figure 4. Simulated Weights Inside Shelter.

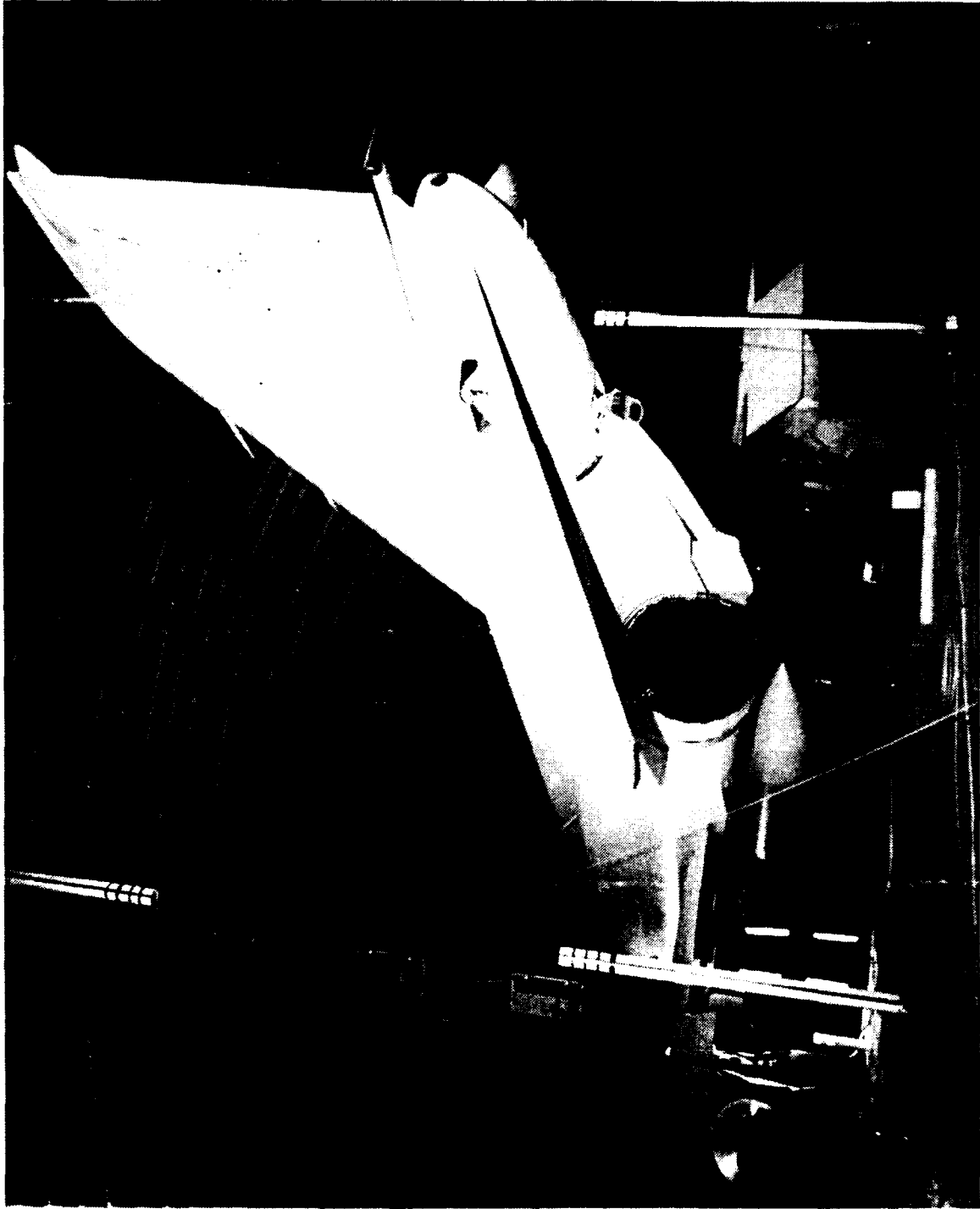

Figure 5. Mock Aircraft Inside Shelter.

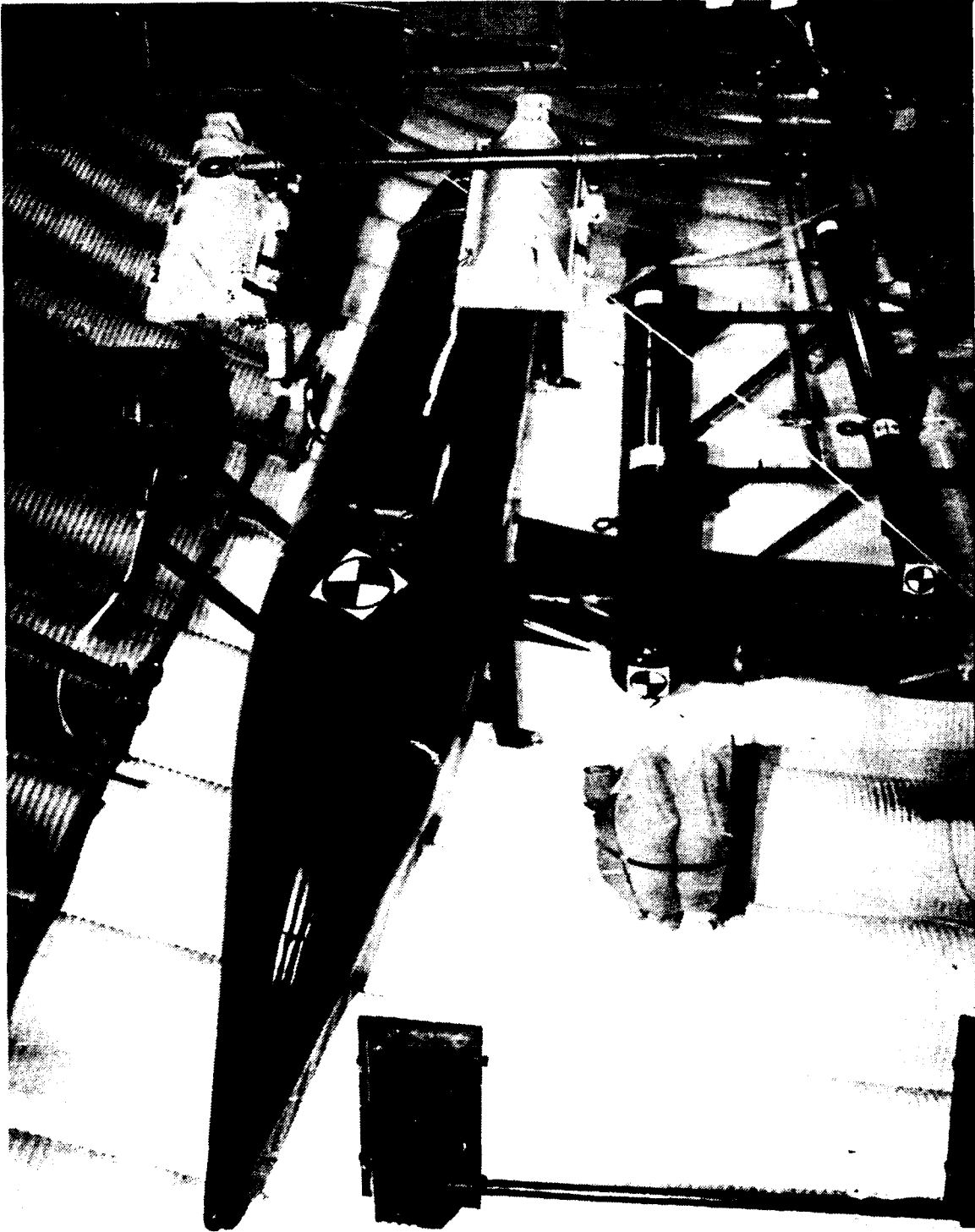

Figure 6. Mock Fuel Tank and Weapons Inside Shelter.

Testing for this project was conducted simultaneously with the Aircraft Shelter Upgrades Program testing and in accordance with the test plan for this project (Reference 7). The test plan includes detailed plans for testing, and the test report (Reference 8) contains descriptions of the as-built equipment, instrumentation, and locations as well as the construction techniques. Relevant data for both the HAS-FPS test and instrumentation design, taken from these two reports, are included herein in order to achieve one comprehensive report.

In summary, real, full-scale HAS-FPS equipment was instrumented in the TGAS, and an actual threat was created to acquire data for this project.

#### E. TEST SCHEDULE

The schedule of test events is presented in Table 1.

TABLE 1. SCHEDULE OF TEST EVENTS.

Test No.	Test Event	Test Date
1	ARS-3	07 OCT 87
2	ARS-1	03 NOV 87
3	FLB-1	20 JAN 88
4	ARS-2	09 JUN 88

## SECTION II MOUNTING HARDWARE

### A. INTRODUCTION

Most of the equipment used for fire testing during the HAS-FPS Project (Reference 1) was used in the tests for this project. However, some of the equipment previously used was not recovered because enhanced concepts for mounting hardware were developed for the harsh environment to be encountered during the blast tests. Specifically, the suppression cylinders, manifolds, nozzles, detectors, and control hardware were the same as for the fire detection and suppression tests, and new mounting hardware was constructed for the purposes of the blast testing. The new mounting hardware is now described in this section.

### B. SUBSYSTEM CONFIGURATIONS

#### 1. Company 'A'

a. One fire suppression agent cylinder is supported on the bottom by a rigid tray, which is welded with formed pipe to the shelter liner along the concave corrugation. The cylinder is secured near the top by a strap, which is also welded to the shelter liner with formed pipe. This is a standard mount design used when blast loading is not considered.

b. One fire suppression agent cylinder (suppressor) is hung on a wire rope, which runs through a pulley attached above to the shelter liner and then down to a hand winch, which is also welded to the inner wall. Slide stabilizers with shear pins are fixed to each of the bottom sides of the cylinder with rotating joints and welded to the shelter liner. This concept minimizes shock and vibration input to the cylinder components because the cylinder is not attached to the wall by means of a hard mount.

c. Two detectors, one with a short hard coupling and the other one with a longer swivel coupling are both rigidly mounted and welded to the shelter liner.

d. One standard "Fire Control Module" with rigid upper and lower flanges is welded to the shelter liner.

2. Company 'C'

- a. One cylinder is hard-mounted to the cylinder-encasing mount, which is attached by chemical bolts (10 inches) driven into the shelter wall. This provides maximum security and coupling of the components to the wall.
- b. One cylinder is antivibration mounted (AVM) to the cylinder-encasing mount, which is welded to the shelter liner. This provides data on the effectiveness of AVMs to reduce the shock and vibration inputs to the cylinder components.
- c. Two detectors with rigid mounts are welded to the shelter liner, thus allowing maximal input to the detector components.
- d. One standard fire control cabinet with rigid side flanges is welded to the shelter liner.

3. NOTE: All cylinders were loaded with water/sand/lead shot to achieve the full ratios and weight of the proposed systems.

C. DESCRIPTION OF COMPANY 'A' MOUNTING HARDWARE

The description of Company 'A' mounting hardware consists of the construction package with comments.

1. Construction Package for Company 'A' Mounting Hardware

The construction package for Company 'A' fire protection hardware modifications is comprised of the following:

- a. The assembly schematic, tray elevation schematic, and construction for the tray cylinder mount are presented in Figures 7, 8, and 9, respectively.
- b. The layout of the wire rope cylinder suspension mount is presented in Figure 10. Plan and elevation views of the suspension assembly are presented in Figure 11.
- c. The construction of the detector mount is presented in Figure 12.

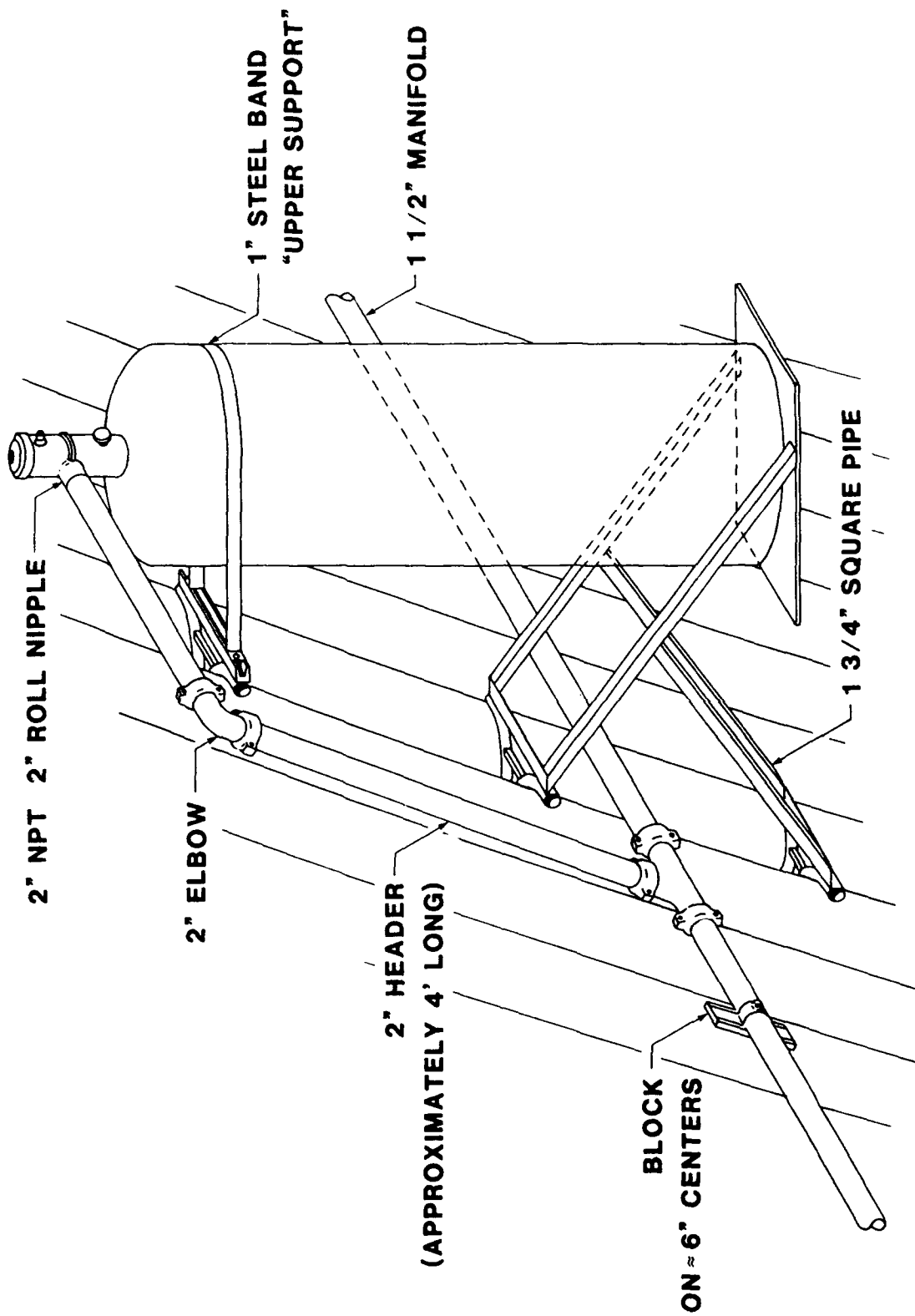

Figure 7. Company 'A' Cylinder/Header/Manifold Assembly.

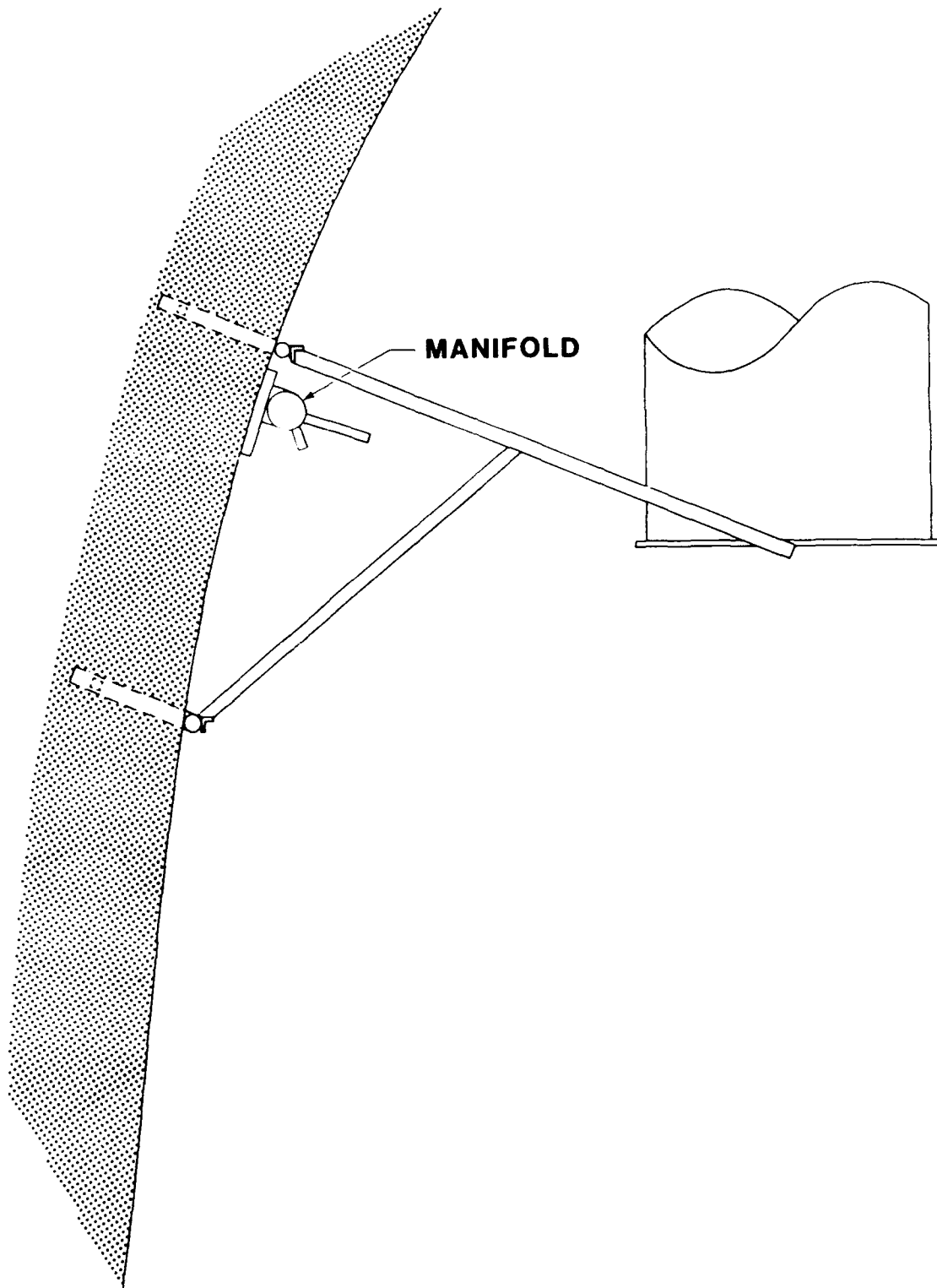

Figure 8. Company 'A' Tray Cylinder Support.

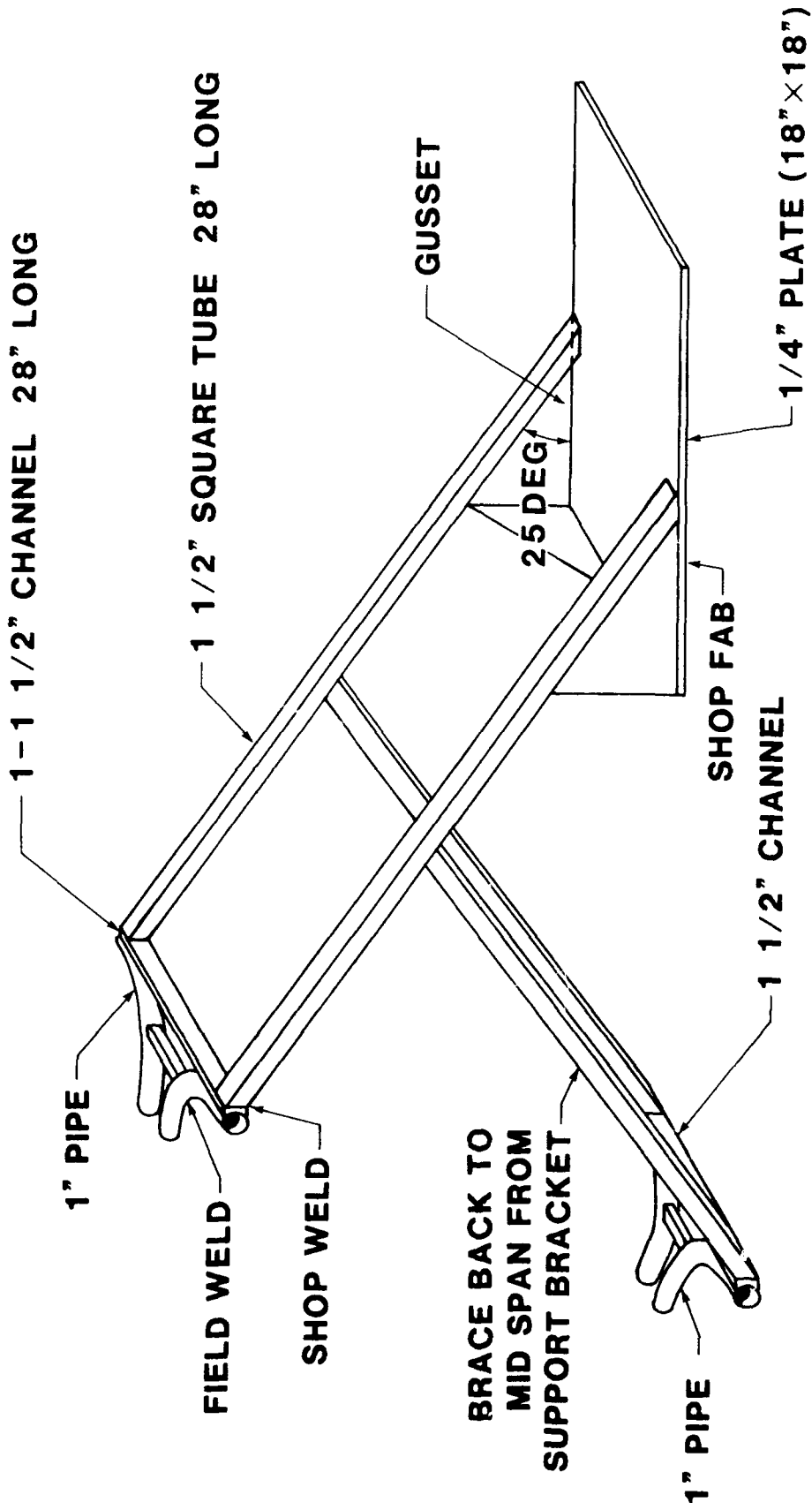

Figure 9. Company 'A' Tray Construction.

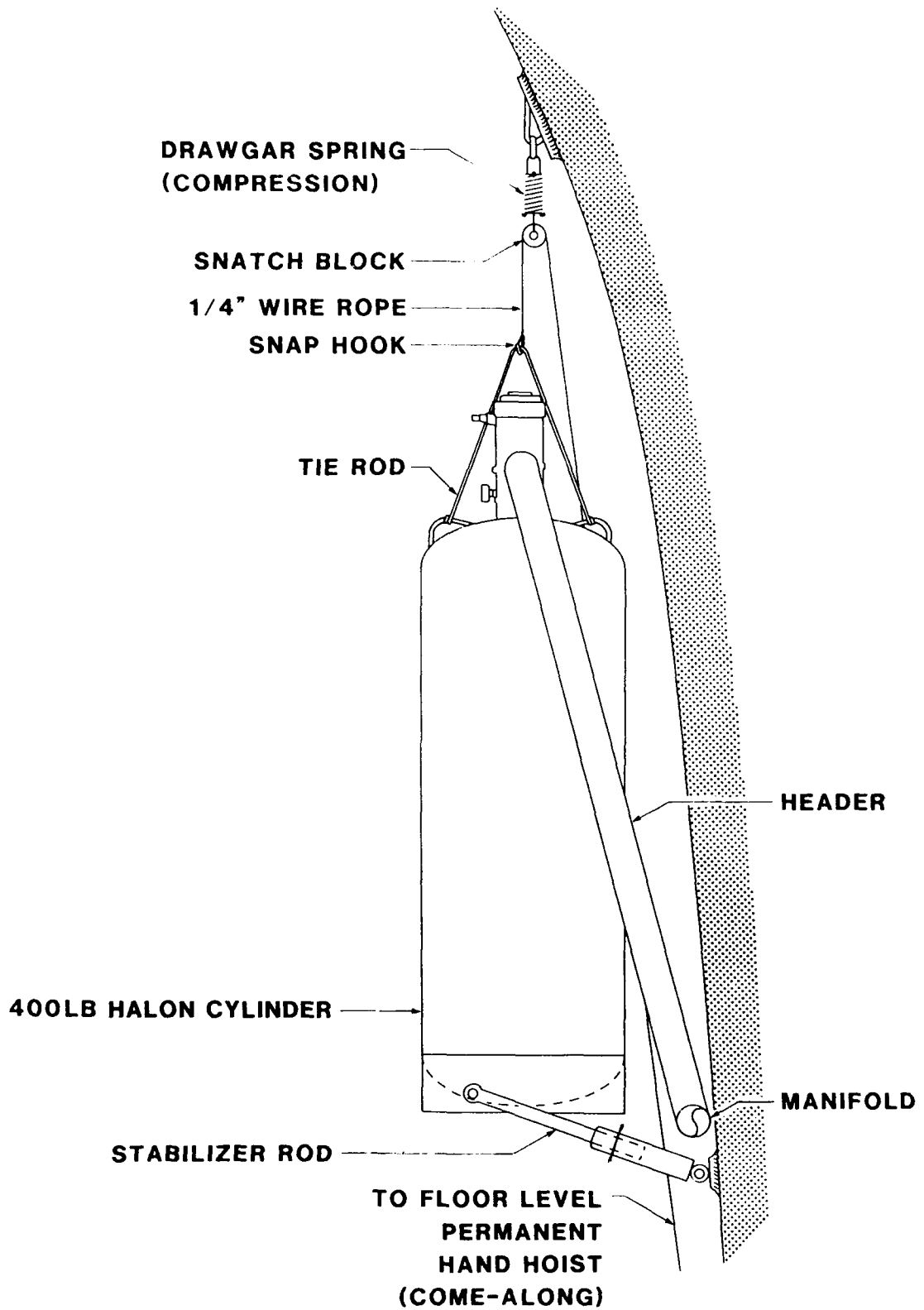
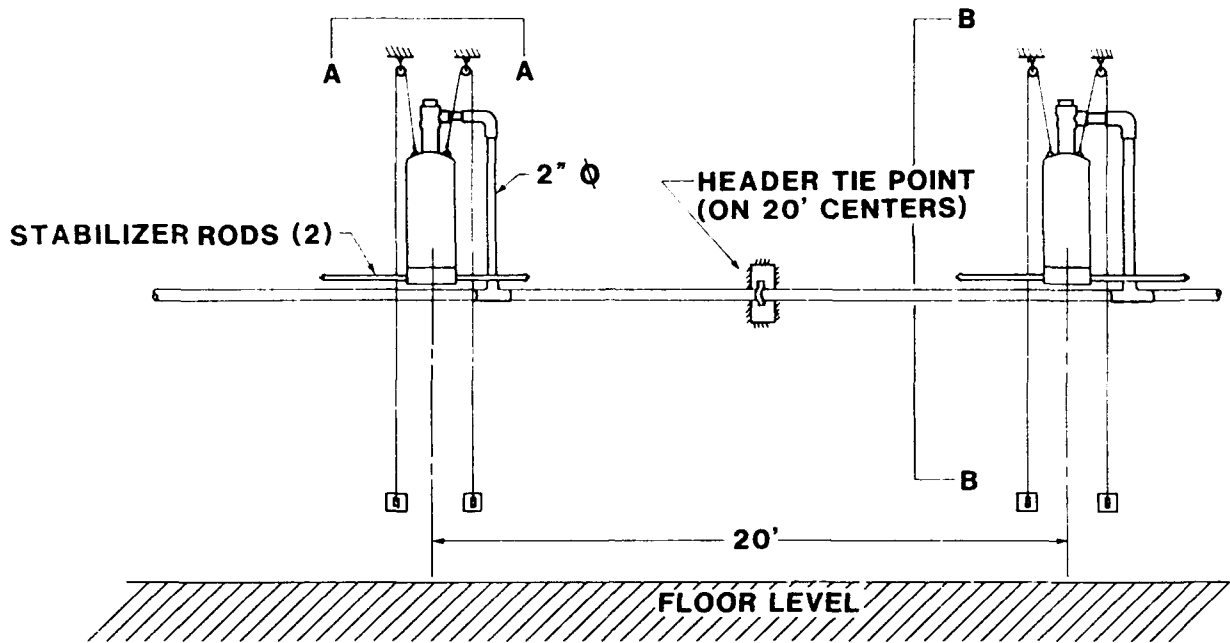
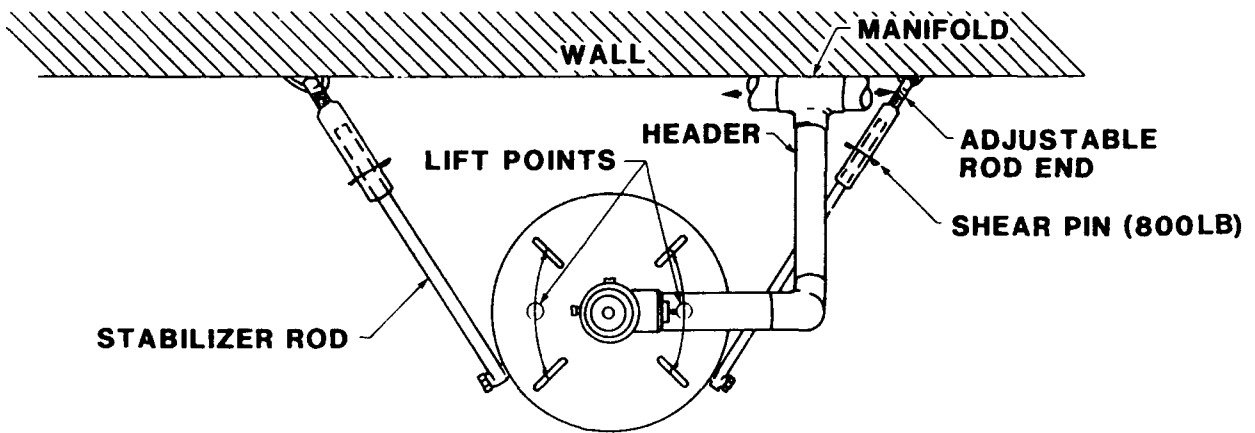

Figure 10. Company 'A' Suspension Cylinder Mount.

**HAS CYLINDER MOUNTING - BLAST RESISTANT**



**ELEVATION VIEW - TYPICAL SECTION OF SYSTEM**



**SECTION A-A**

Figure 11. Company 'A' Cylinder Suspension Assembly.

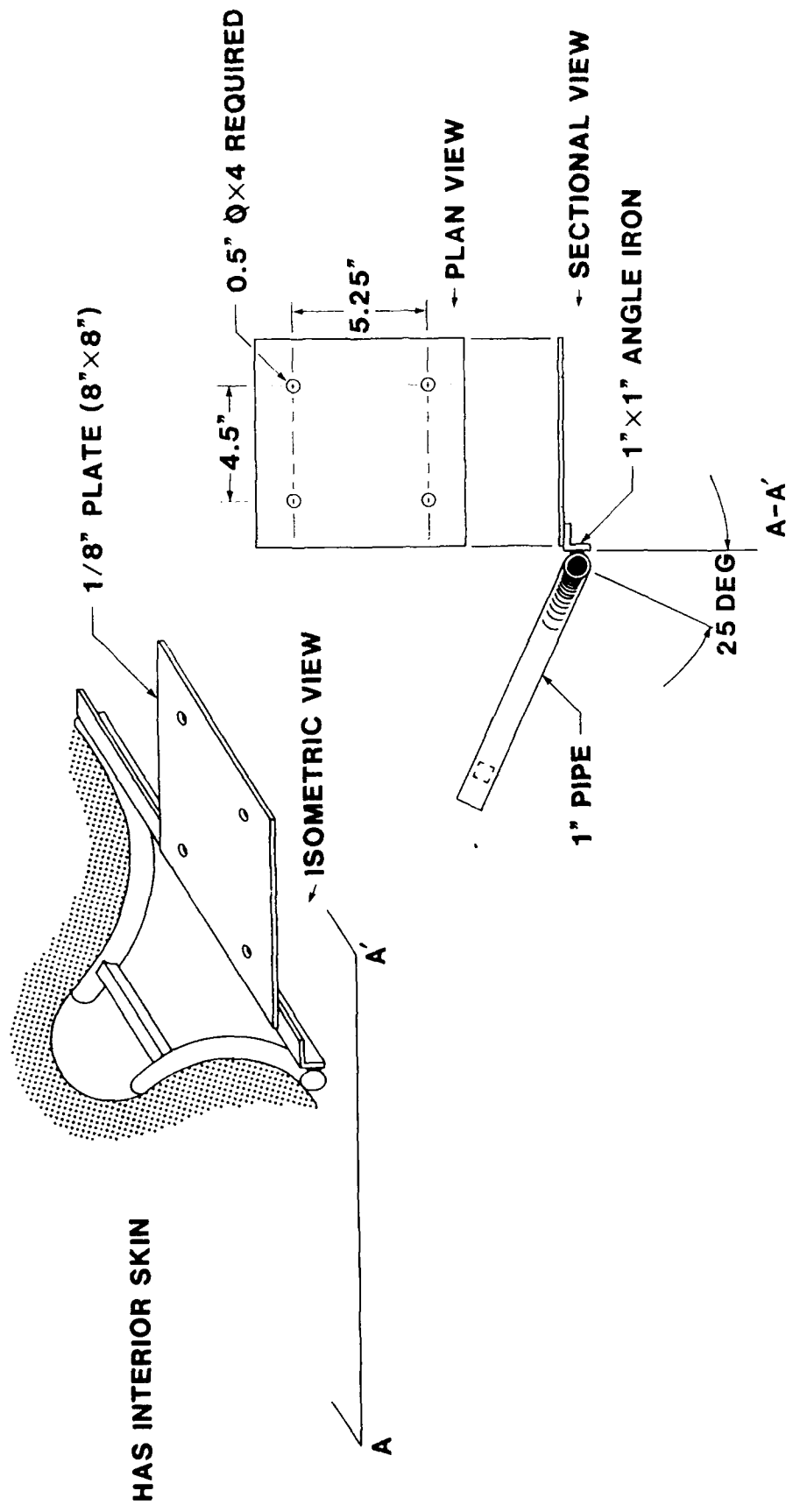

Figure 12. Company 'A' Detector Bracket.

d. The layout of one complete suppressor manifold is presented in Figure 13 and one 20-foot section was used with each of the single cylinder tray assembly (Figure 7) and the single cylinder suspension assembly (Figure 10) for testing.

e. The description of the control module is presented in Figure 14.

f. Comments: It is believed that the suspension mounting scheme is superior to the trays used for fire testing for the following reasons:

(1) The shock-mounted suspension basically isolates the cylinder from wall movement. The thin wall header, tied down only on 20-foot centers will flex (and rotate at V-Band couplings) to accommodate the differential movement from wall to cylinder.

(2) The adjustable stabilizer rods attached to the skirt will provide stability under normal conditions. A shear pin will prevent high load input during blast conditions. The loss of rod shear pins will not affect subsequent system operation.

(3) This scheme does not require the tray weldment, an expensive item.

(4) Trays are not adjustable in height: the suspension scheme is.

(5) Serviceability is superior. A cylinder could be lowered and replaced within 1/2 hour (by two persons) with no additional equipment required.

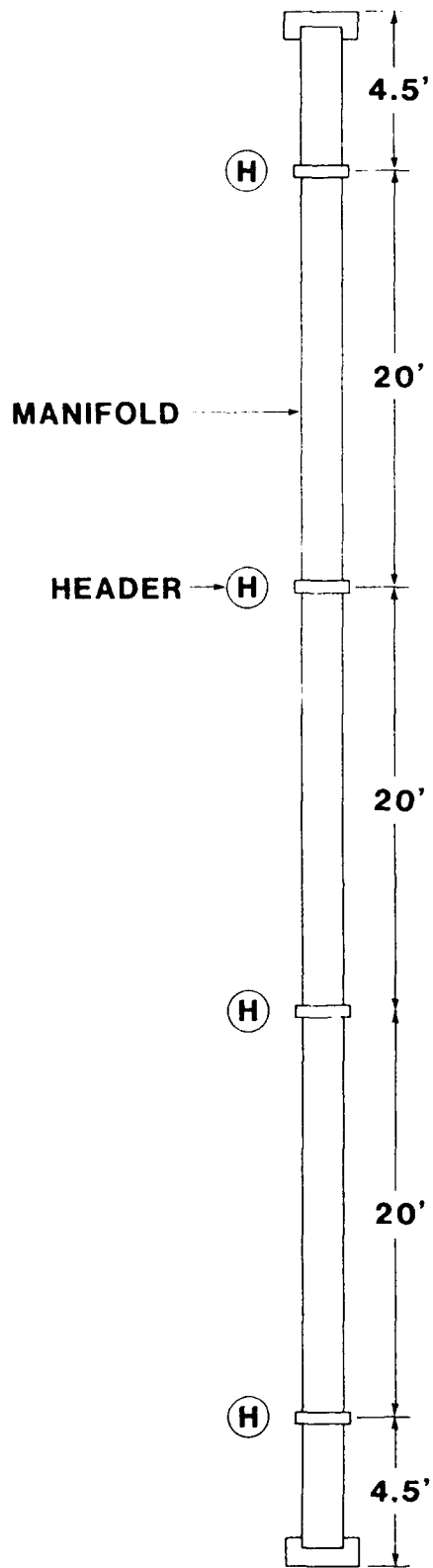
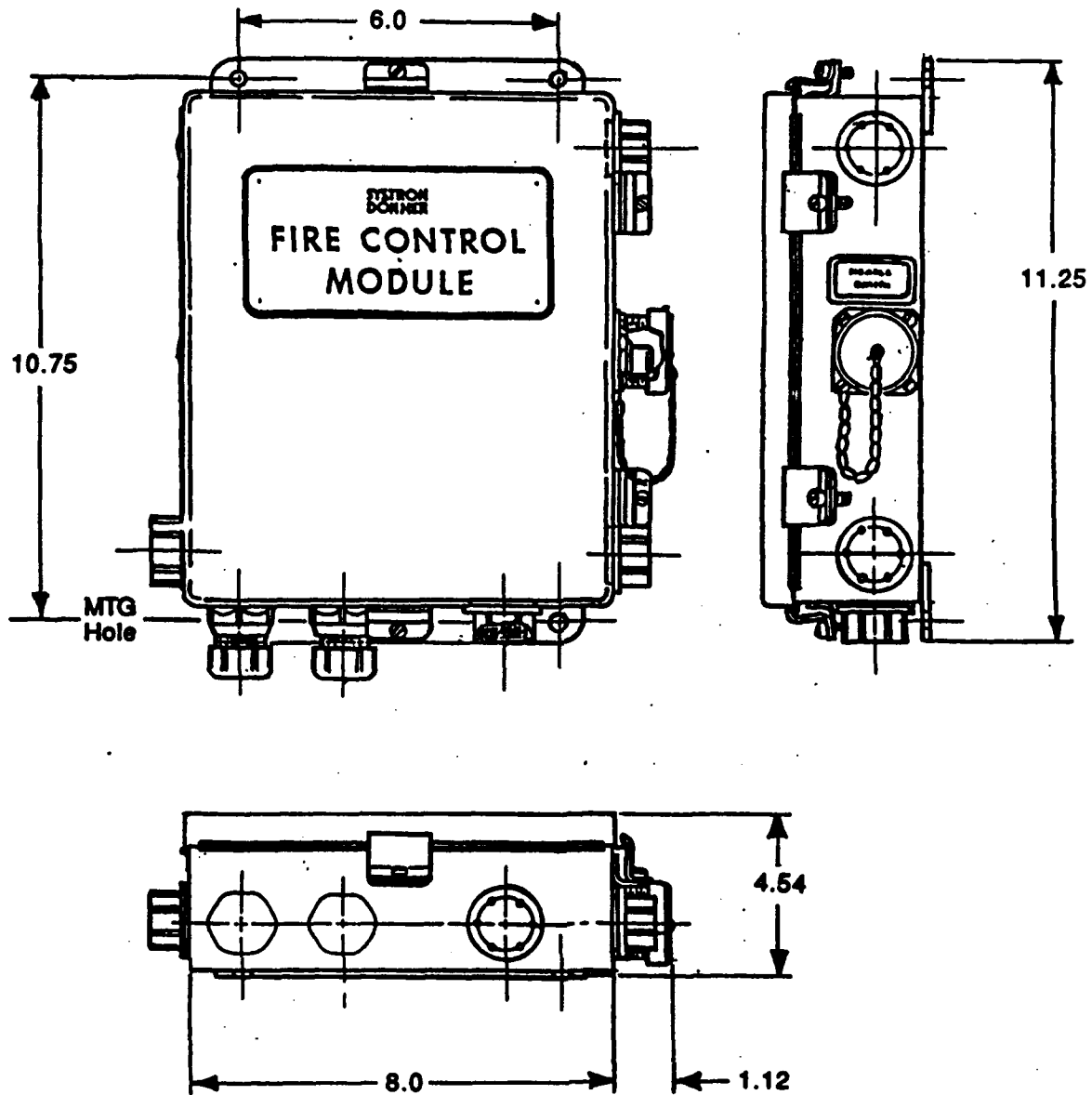

Figure 13. Company 'A' Agent Manifold.



Reproduced with permission of  
 Systron Donner, Concord, CA

**Notes:**

1. All Dimensions Ref. only.
2. Materials of construction
  - a. Enclosure: P/N 5902-1-2 : 14 ga. stl., painted red.  
 P/N 5902-3, -4, -5, and -6 Type 304 stl., painted red.
  - b. Hinge Pin, Cover Clamps and Screws: Stainless stl.
  - c. Cover Gasket: Neoprene.
3. Module suitable for exterior mounting.

Figure 14. Company 'A' Fire Control Module.

## D. DESCRIPTION OF COMPANY 'C' MOUNTING HARDWARE

The description of Company 'C' mounting hardware consists of the design philosophy, construction package with comments, and instructions for installation.

### 1. Design Philosophy

The task was to design a support for mounting a 500-pound agent suppression cylinder on the inside wall of a HAS. The support was to be capable of securing a cylinder (suppressor) against shock input from a bomb blast.

The previous HAS-FPS cylinder support used for fire suppression testing consisted of a bracket fabricated from 3 x 3 x 1/4-inch angle iron, which was welded to the interior, galvanized steel liner of the HAS. The suppressor was mounted to the bracket by bolting through simple lugs, which had been welded to the suppressor. The lugs had no stiffening webs. Simple stress calculations showed that, although the bracket was likely to be of adequate strength, the cylinder lugs were too weak to sustain high shock loads.

#### a. Suppressor Mounting Lugs

It was decided to remove the existing lugs from the suppressor and replace them with reinforced (webbed) lugs of a strength consistent with that of the support bracket. The webs provided resistance to the vertical component of the shock input while the lug width was wide enough to enable it to resist the horizontal component of the shock input (in the transverse axis of the HAS).

#### b. Support Bracket

No substantive modification to the support bracket was considered necessary.

#### c. Attachment to the HAS Liner

(1) General: The shelter liner of the HAS consists of galvanized steel plate, approximately 1/8 inch thick, which is convoluted both horizontally and vertically to increase its structural stiffness. Since two suppressor installations were to be subjected to the test, it was decided to attach one bracket to the shelter liner by welding and the other by bolting.

(2) Welded attachment: Because of the thinness of the liner, there was concern that welding the suppressor support system to it might cause the liner to pull away from the concrete wall as a result of the bomb blast shock. To reduce the likelihood of this, it was decided to interpose shock mountings between the suppressor lugs and the support bracket.

(3) Bolted attachment: The bracket was to be bolted to the wall and passed through its entire thickness. Either one 1-inch diameter or two 3/4-inch diameter bolts were to be used at each of the six mounting pads on the bracket. The suppressor was to be bolted solid to the bracket with no shock isolation provided.

d. Further Considerations

(1) Attachment to the HAS liner: The test should be repeated without shock isolation of the welded attachment to ascertain whether the shelter liner can in fact resist the direct shock loading.

(2) Effect on discharge head and spreaders: Furthermore, it would be worthwhile to conduct repeat tests with the discharge head and spreaders fitted to the suppressors. This should be done on both systems, i.e., with and without shock isolation. This test is desirable to establish whether the discharge head and spreaders can withstand the stresses developed as a result of the shock input.

2. Construction Package for Company 'C' Mounting Hardware

The construction package for Company 'C' fire protection hardware modifications includes the following:

a. Figures 15, 16, and 17: ISK 150--The bracket arrangement originally supplied for the fire suppression tests of the 250 and 500 lb suppression cylinder supports.

b. Figures 18 and 19: MSK 831--A drawing showing the alterations to ISK 150 in order to accommodate shock mounts and welded attachment of the bracket to the shelter. The drawing also illustrates the revised lug design with reinforcement.

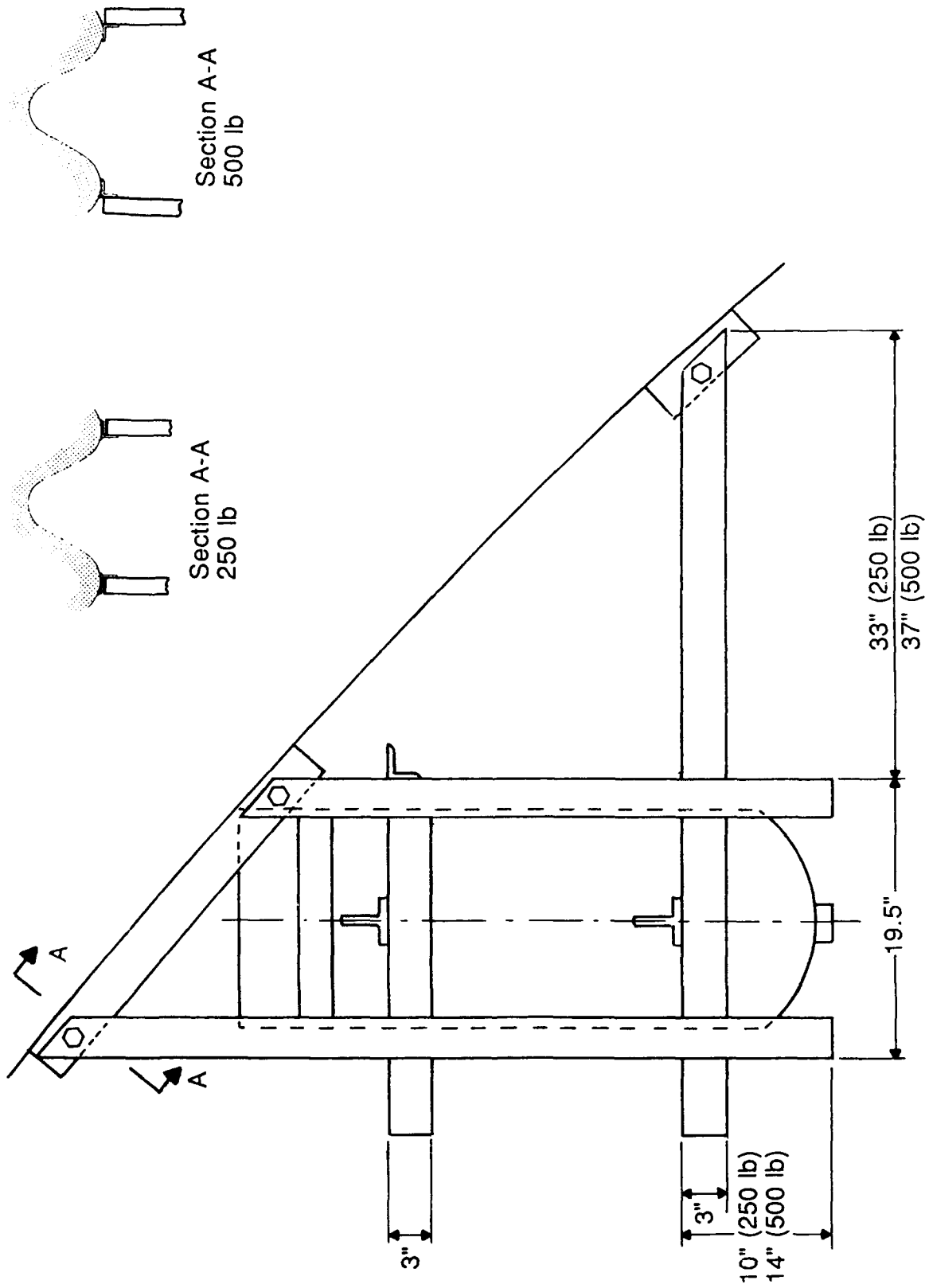

Figure 15. Company 'C' Bracket for Tyndall Air Force Base.

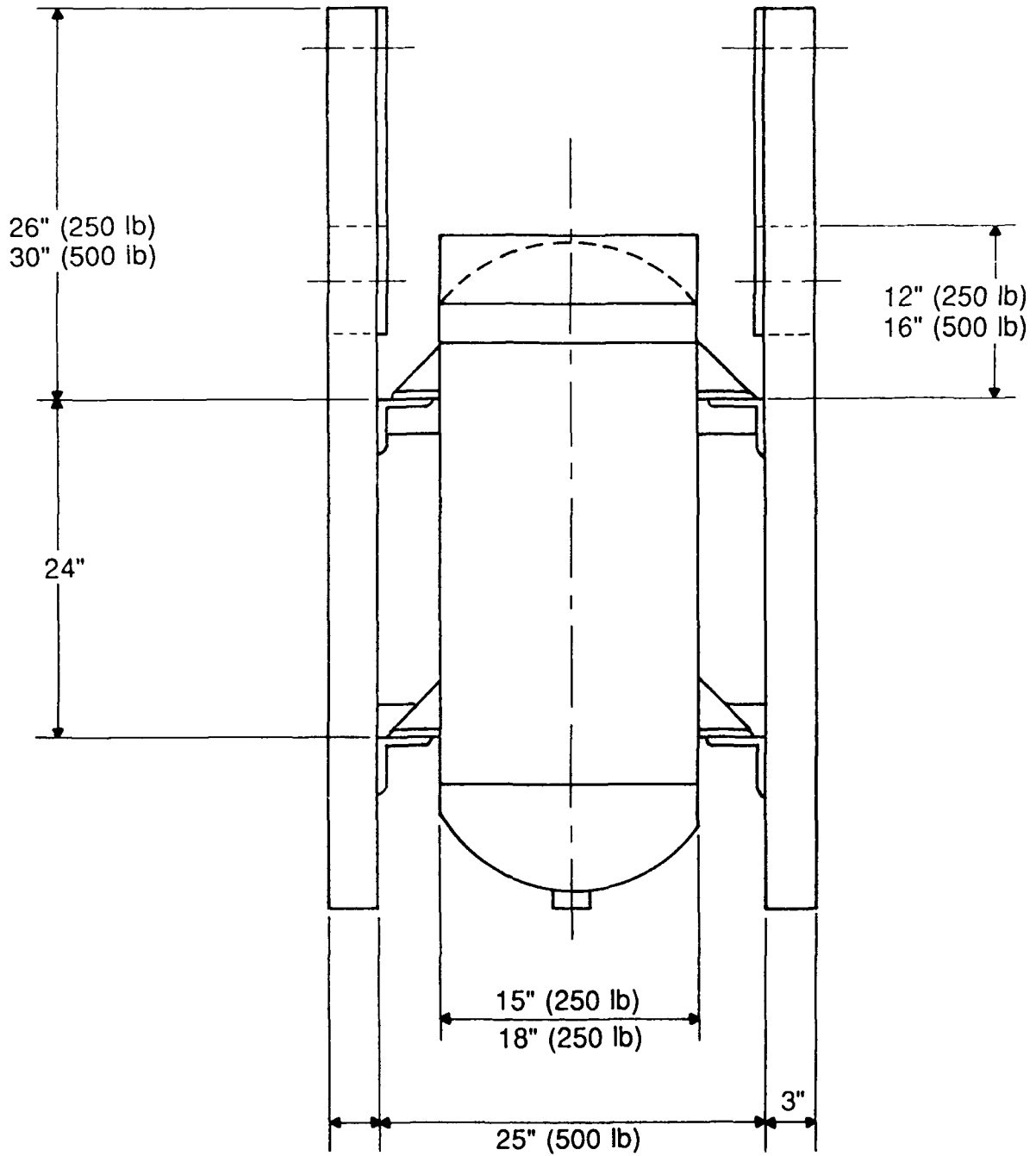

Figure 16. Company 'C' Bracket for Tyndall Air Force Base.

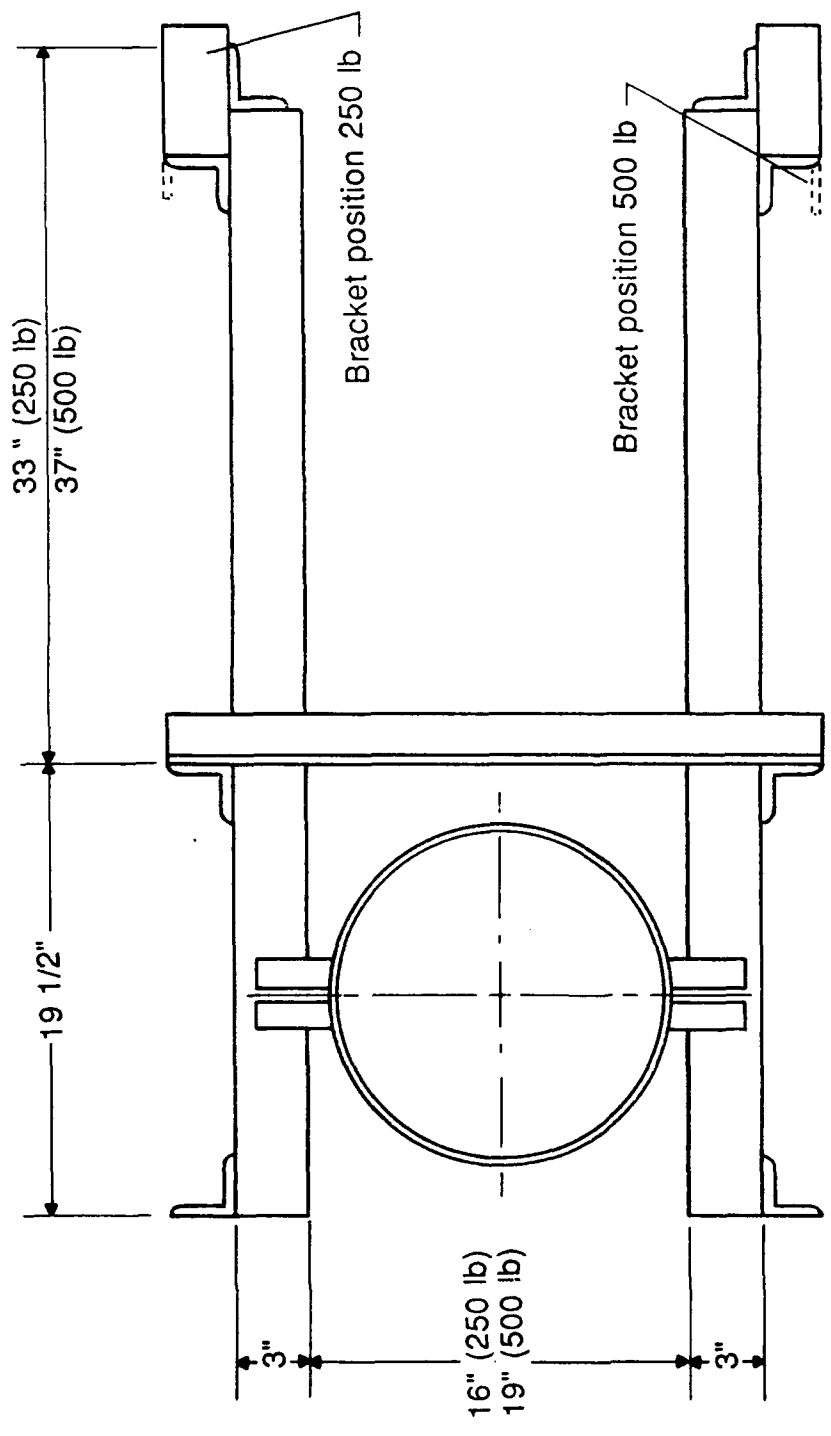

Figure 17. Company 'C' Bracket for Tyndall Air Force Base.

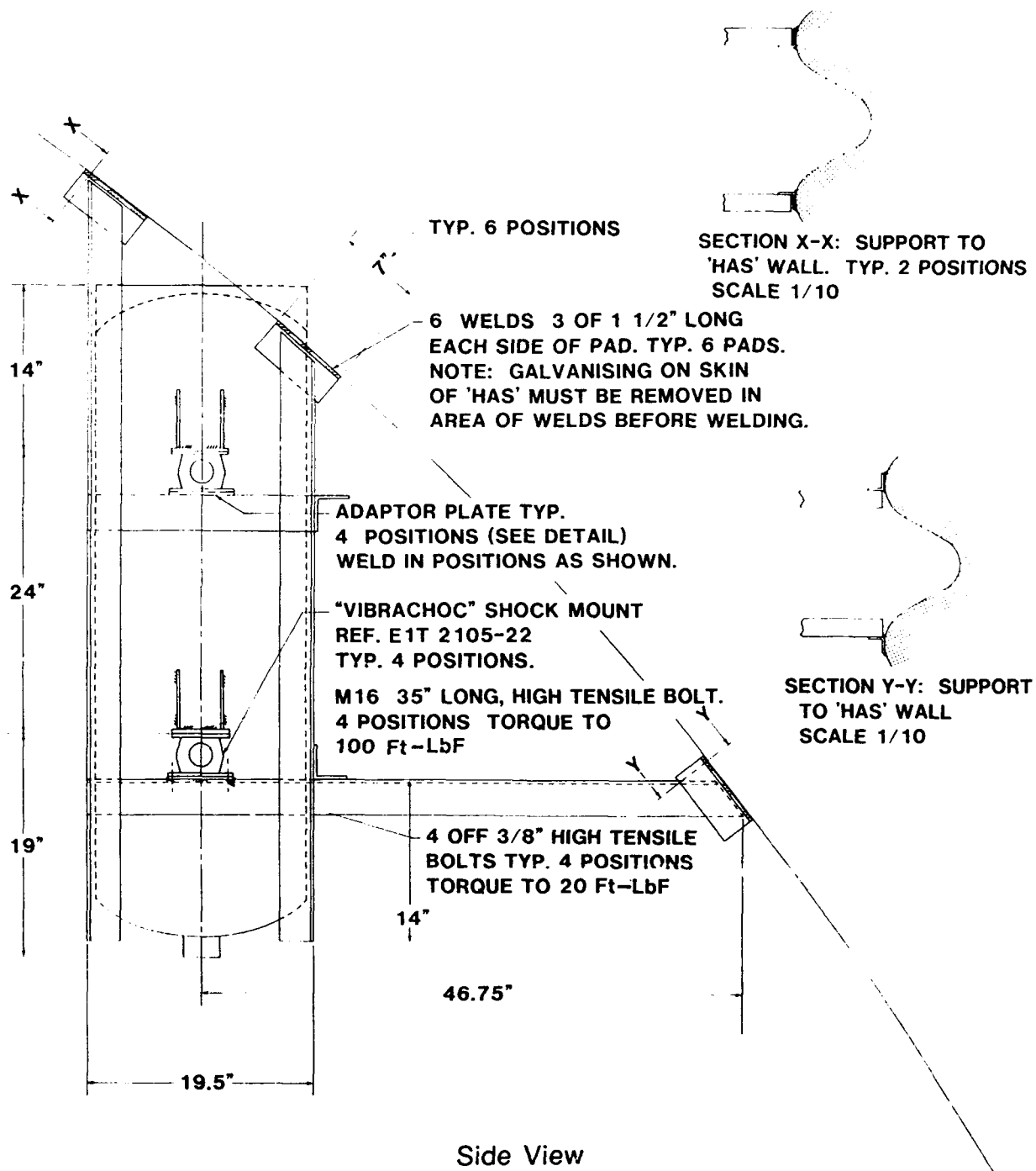

Figure 18. Company 'C' Cylinder Assembly with Shock Mount.

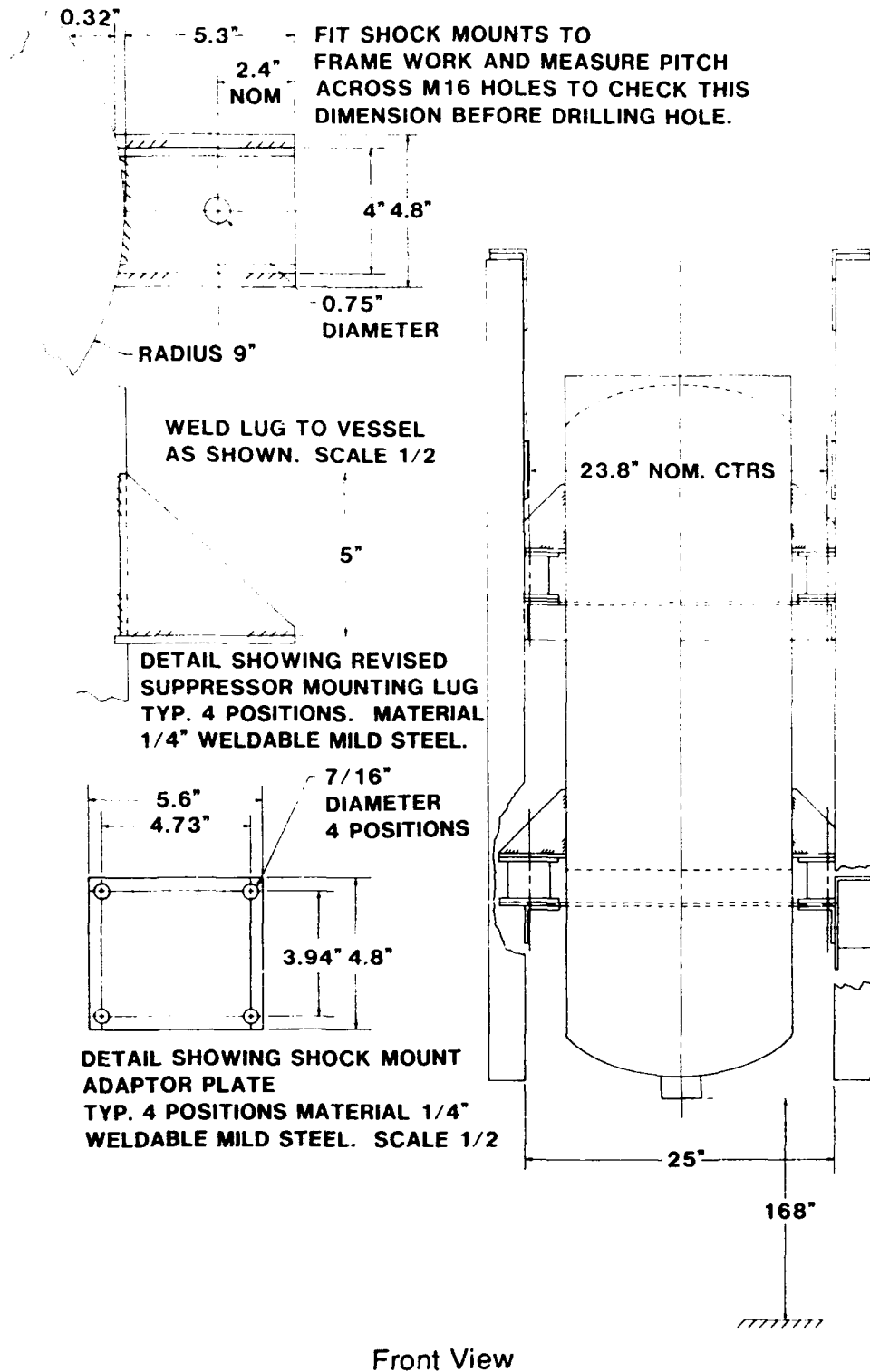

Figure 19. Company 'C' Cylinder Assembly with Shock Mount.

c. Figures 20 and 21: A "marked up" drawing based on MSK 831, which shows the modifications necessary to adapt the bracket for use without shock mounts and the means of attachment to the shelter using bolts or studding.

d. Figure 22: MKS 835--A drawing showing the design and construction of the detector bracket for use in the trials.

e. Comments: The instructions for installation have been written assuming that the original brackets used for the fire tests can be retrieved and refurbished. However, it is important to construct new brackets for the following reasons:

- (1) The original units will be significantly corroded.
- (2) The quality of the welding on those units is questionable.
- (3) Since parts of those units were constructed in situ, they will not dimensionally match the drawings.
- (4) It will be difficult to remove them from the fire test shelter without damaging them.

Further information can be gained from a limited number of tests by welding the "with shock mounting" suppressor to the HAS wall and by bolting the rigidly constructed bracket through the concrete.

Useful data will be gained by locating the accelerometers on the following vertical and horizontal movement pairs:

- (1) The suppressor lugs for both "shock mounting" and "rigid" construction arrangements.
- (2) The upper support of the bracket close to the attachment to the shelter.
- (3) The lower support of the bracket close to the attachment to the shelter.

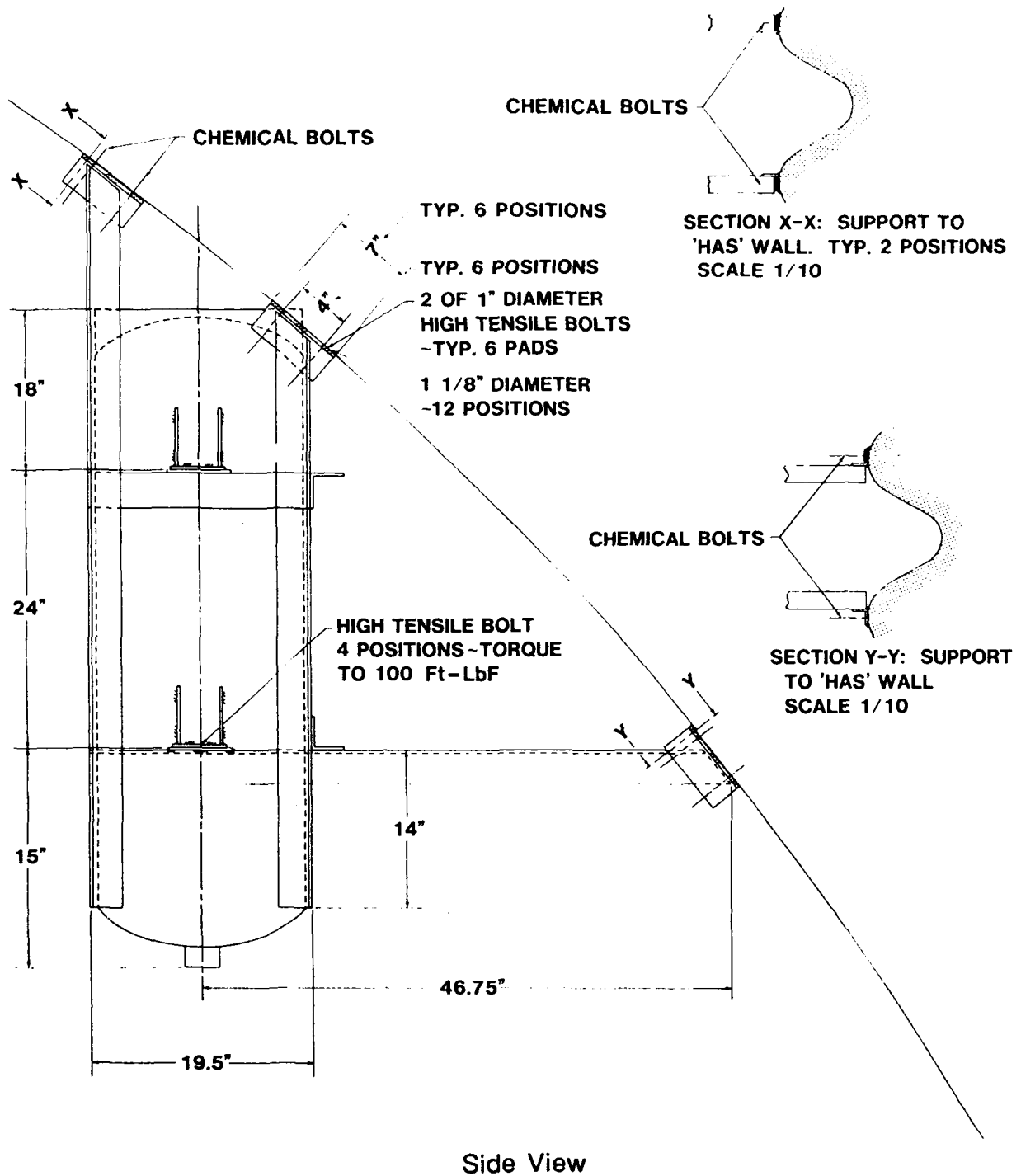

Figure 20. Company 'C' Cylinder Assembly without Shock Mount.

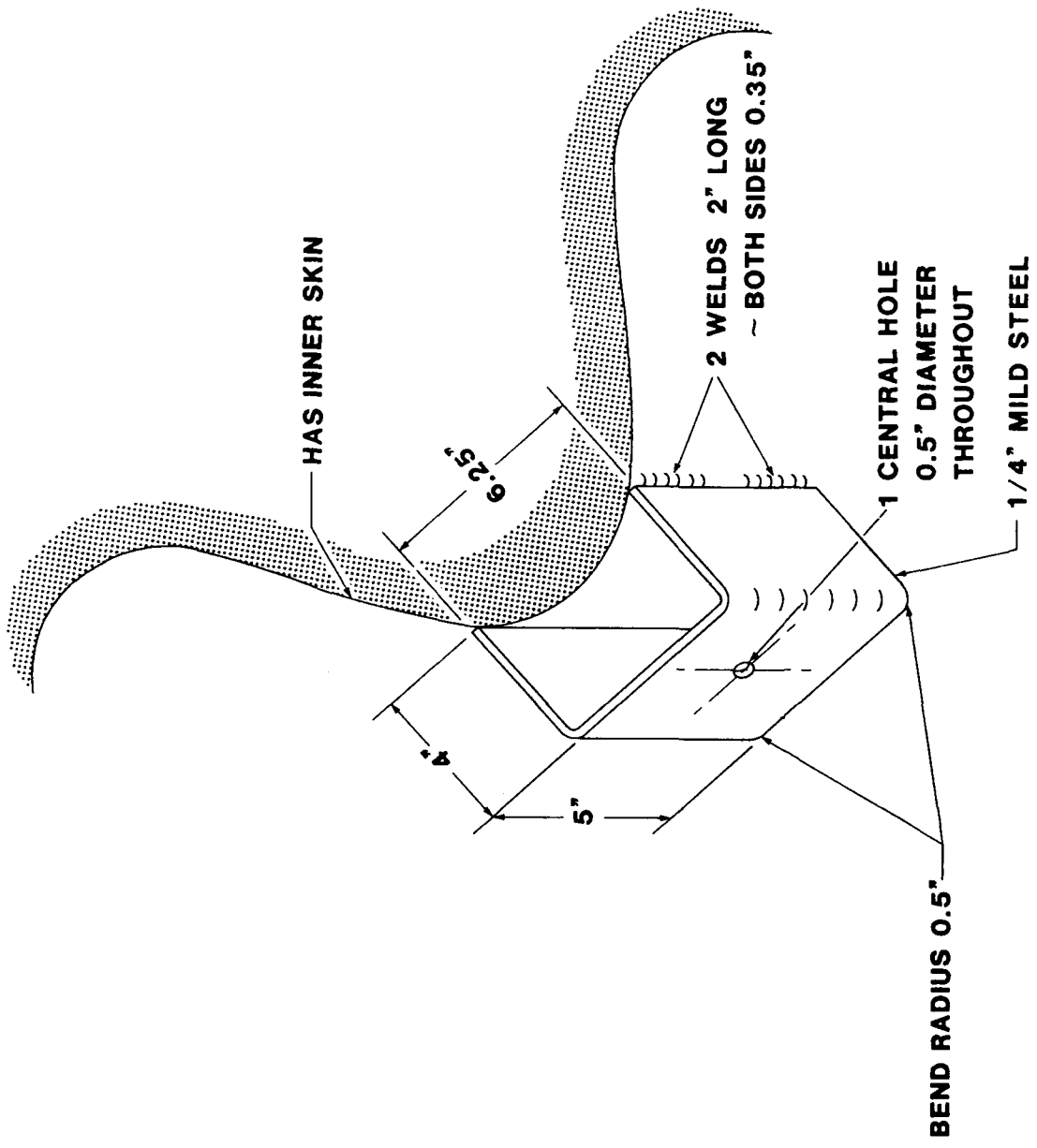
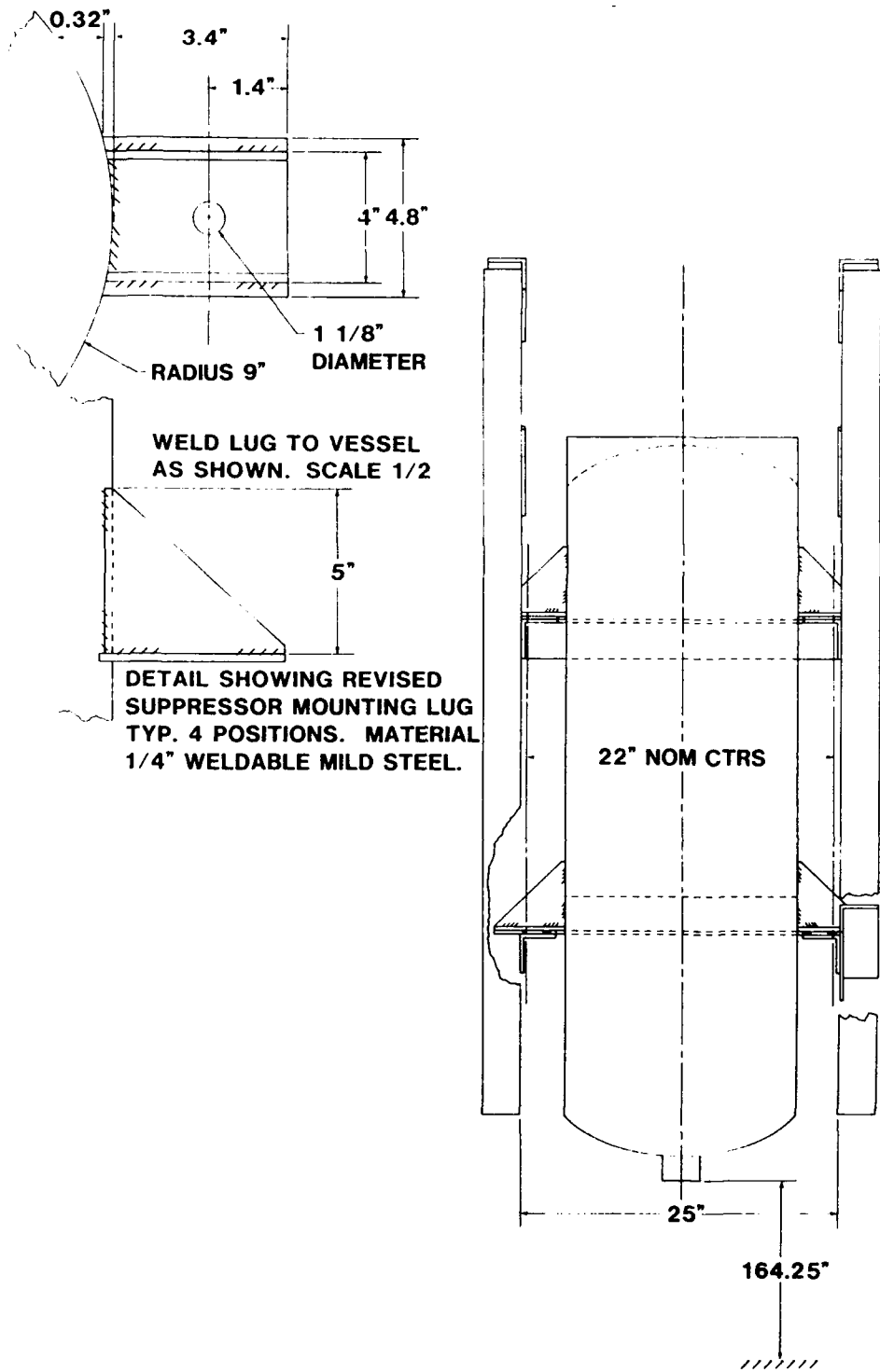

Figure 22. Company 'C' Detector Bracket.



Front View

Figure 21. Company 'C' Cylinder Assembly without Shock Mount.

3. Instructions from Company 'C' for Installation

The instructions from Company 'C' for installation and mounting of suppressors and detectors are presented in the test report (Reference 8).

### SECTION III TEST ARTICLES

Full descriptions of the HAS-FPS program fire-test detection/ suppression articles are presented in the final report (Reference 1) for that project. Specifically, items from Companies 'A' and 'C' were used for the blast tests because they had originally been built and tested with the cylinders supported upon the side walls. The current project required data for mounting the cylinders on the side walls in accordance with the HAS-FPS Purchase Description. Additionally, the cylinders used in the blast tests represented the range of sizes that could be mounted on the side walls of the shelter.

The tray mount and detector assemblies of Company 'A' are shown in Figure 23 and the suspension mount is shown in Figure 24. The hard-mounted cylinder assembly of Company 'C' is shown in Figure 25; the anti-vibration mount is shown in Figure 26. The fire control module and optical fire detector of Company 'C' are shown in Figure 27.



Figure 25. Hard Mount for Company 'C' Cylinder.

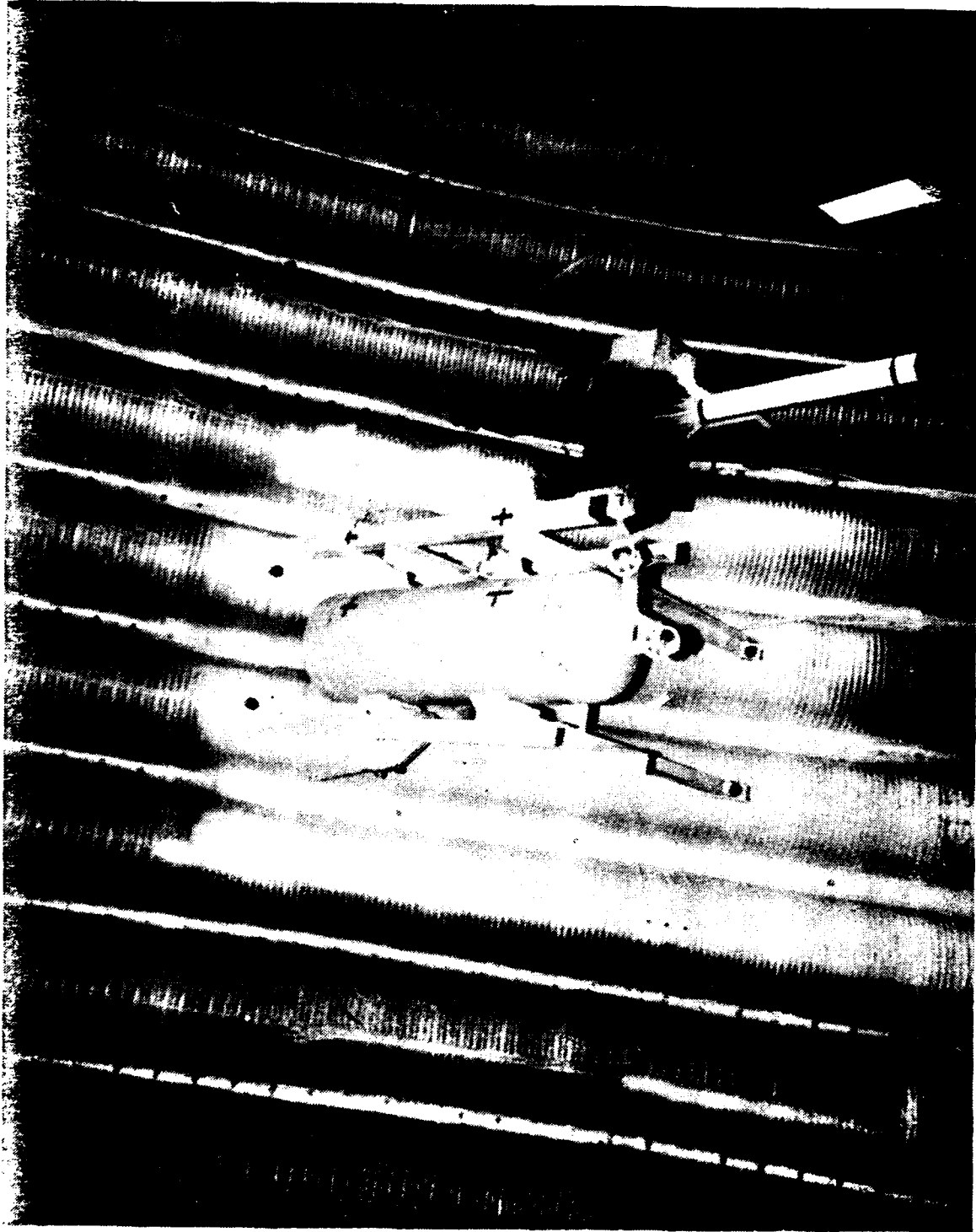

Figure 26. Anti-Vibration Mount for Company 'C' Cylin

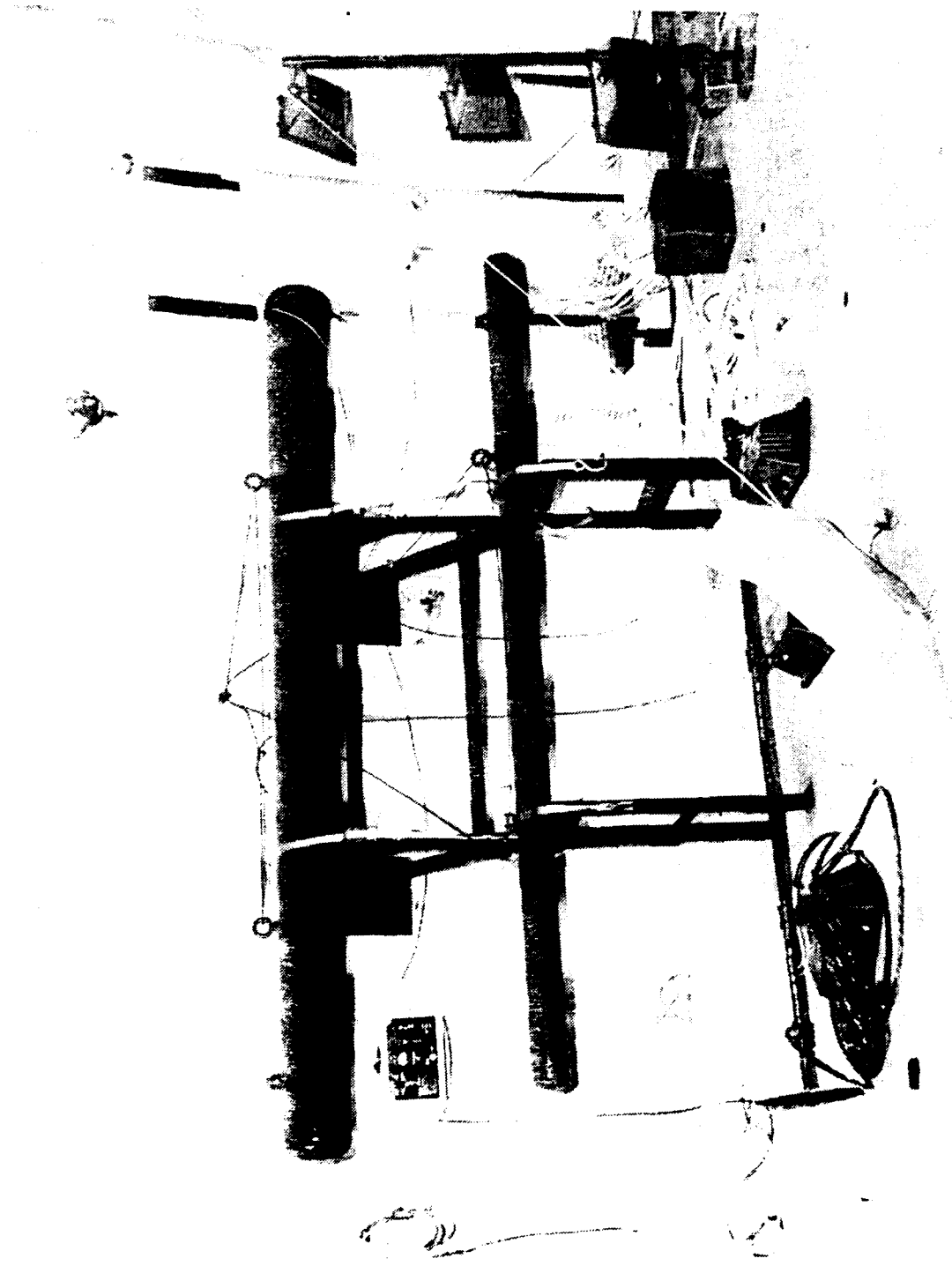

Figure 27. Control Module and Detector Mounts for Company 'C' Hardware.

## SECTION IV EQUIPMENT LOCATIONS

### A. AS-BUILT HARDWARE GENERAL LOCATIONS

1. The package of drawings and installation instructions for the Company 'C' hardware is presented in Section II. The only as-built change was the replacement of the two 3/4-inch diameter bolts specified at each mount pad with a single 1-inch diameter chem-bolt.

2. The package of drawings and descriptions for the Company 'A' hardware is presented in Section II.

### B. HARDWARE MOUNTINGS/LOCATIONS FOR FIRST TEST EVENT

1. All fire detectors were located near the suppression cylinders as anticipated in the final layout for the HAS-FPS. All detectors are required to be at least 10 feet above the shelter floor. All detector brackets/mounts were welded to the shelter liner.

2. Two fire control modules were mounted, one on each inner side of the shelter, near the electrical panel, which may be located on either side near the front of the shelter. Flanges were welded to the shelter liner; the brackets of the control module were bolted to the flanges.

3. The Company 'C' assembly without the anti-vibration mount (AVM) was bolted into the shelter wall and positioned directly in line with the ARS-3 event. This hard assembly provides maximum input to the heaviest cylinder for the first test (ARS-3).

4. The Company 'C' cylinder assembly with the AVM was positioned in line with the ARS-1 event to achieve maximum input for that test. This assembly was welded to the shelter liner.

5. Both Company 'C' modular cylinder assemblies were located on the ARS side of the shelter. Both manifolded Company 'A' cylinder assemblies were located on the FLB side of the shelter and in line with those events.

6. Both the Company 'A' tray and suspension cylinder assemblies were welded to the shelter liner. In order to achieve the proper height for each cylinder and to install the suspension strain gage link, it was not possible to use a continuous manifold. This situation is acceptable for the current testing because the manifold is tied to the wall every 10 feet. Therefore, the original

Company 'A' manifold was modified into two separate 20-foot sections, one section being used for each cylinder.

7. The Company 'A' tray-supported cylinder was mounted farthest from the rear of the shelter and was considered to represent a design of limited application in blast environments. The chosen location for the tray mount would not provide maximal data when considering the locations for the first test event. The Company 'A' suspension mount was located to provide maximal data during the ARS-3 event.

8. The Company 'A' cylinders were mounted so that the bottom of each cylinder was 10 feet above the floor. The Company 'C' cylinders were mounted so that the nozzles were approximately 13 feet above the floor.

9. Using a right-hand coordinate system with its origin at the center of the rear exhaust doorway and at floor level when looking forward to the front entry/exit doorway, the general locations of hardware planned for the first test event are as follows:

- a. Company 'C' cylinder without AVM was bolted near the right rear;
- b. Company 'C' cylinder with AVM was welded near the right front;
- c. Company 'A' suspension cylinder was welded near the left rear;
- d. Company 'A' tray cylinder was welded near the left front;
- e. Company 'C' control box was welded near the right front;
- f. Company 'A' control box was welded near the left front; and
- g. Detectors were welded near the cylinder.

10. Company 'A' hardware was installed after the first test event.

11. The locations of the mounting pads for the Company 'C' cylinder mount assembly without the AVM and for the Company 'C' cylinder mount assembly with the AVM were presented in the test report (Reference 8).

12. Locations of gages on the Company 'A' and Company 'C' detectors and control modules were presented on the guage information sheets in the test report (Reference 8).

### C. HARDWARE MOUNTINGS/LOCATIONS FOR SUCCESSIVE TEST EVENTS

1. The changes in hardware mountings and/or locations from the first test event to the second test event are as follows:

a. The Company 'A' tray-mounted cylinder, suspension-mounted cylinder, and detectors were installed.

b. The original Company 'A' suspension mount spring system had to be reworked because the purchased springs did not meet the specifications; that is, there was not enough play remaining after the cylinders were loaded. Therefore, 100 lb/in. springs were constructed for the Company 'A' suspension mount. The details of this construction were presented in the test report (Reference 8).

c. The Company 'C' AVM system was welded to the shelter liner for the first test, so it was bolted for the second test. It was concluded that (a) sufficient data for the welded configuration had been obtained; (b) the liner may have moved from the as-built shelter as a result of the first test; and (c) alternate data should be acquired for this practical AVM design with a chem-bolt installation.

2. The locations of the mounting pads for the Company 'A' cylinder suspension mount assembly and for the Company 'A' cylinder tray mount assembly are presented in the test report (Reference 8). Additionally, the locations of mounting pads for the manifold associated with the Company 'A' suspension assembly and for the manifold associated with the Company 'A' tray assembly are presented in the same test report.

3. The locations of all equipment remained the same for the second, third, and fourth tests except for the following:

a. The Company 'A' fire control module was installed for the third and fourth tests.

b. The Company 'C' cylinder assembly without the AVM was attached by chemical bolts to the previous location of the Company 'A' cylinder suspension for the fourth test. This was done in order to get maximal input data for the configuration of the last test event (ARS-2).

SECTION V  
GAGE INFORMATION

A. INSTRUMENTATION PLAN

The instrumentation plan that appeared in the test plan (Reference 7) is summarized in the following paragraphs. The instrumentation summary, which compares the measurement number and axis with the nominal hardware definition and location, is given in Table 2. The initial priorities for the instrumentation, which depended on technical value, are presented in Table 3 by description and in Table 4 by measurement numbers.

B. DESCRIPTION OF TEST INSTRUMENTATION

The comparison of measurement numbers to the accelerometer transducer model/range is presented in Table 5. The model description, calibration procedures and data sheets for the accelerometers are presented in the test report (Reference 8).

The coordinate system for all measurements is 0,0,0 on the center of the floor at the rear of the shelter (aircraft exhaust port) with the x-axis forward along the shelter axial dimension, the z-axis vertically upwards from the floor, and the y-axis diametrically from the shelter axial dimension.

1. Test 1 : ARS-3

The original instrumentation matrix from the test plan (Reference 9) is presented in Table 3. The instrumentation actually used in Test 1 is that defined in Tables 3 and 4 as EVENT ARS-3 FIRST PRIORITY, which consisted of 14 accelerometers and 2 cameras.

The as-built locations and serial numbers of the gages used for Test 1 are presented in Table 5.

TABLE 4. INSTRUMENTATION MEASUREMENT NUMBERS FROM TEST PLAN.

Actual Test Number	Event	First Priority	Second Priority	Third Priority
1	ARS-3	8601y, 8602z, 8603y, 8604z, 8605y, 8606z, 8607y, 8608z, 8609y, 8610z, 8624y, 8625z 8626y, 8627z	8614y, 8615z, 8616y, 8617y, 8618z	8612y, 8613z, 8611x, 3905z 3901z, 3902y, 3903z, 3904y
2	ARS-1	Same as Test 1 Except Disconnect 8626y, 8627z, 8603y, 8604z, 8609y, 8610z	8626y, 8627z 8603y, 8604z 8609y, 8619z	
--	FCS-1	8619x, 8629x, 8611x, 8623x, 8621x, 8622x, 8628x		
3	FLB-1	8612y, 8613z, 8614y, 8615z, 8616y, 8617y, 8618z, 8611x, 3901z, 3902y, 3903z, 3904y, 3905z		

TABLE 5. MEASUREMENT LIST AS BUILT FOR TEST 1.

Meas. No.	As-Built Location			Sensitivity Axis	Transducer Model	Transducer Range (g)	Description	Company	Serial Number
	x	y	z						
8601	31'2 1/4"	-25'10 1/4"	15' 1/8"	y	2264	2000	Hard Mount Lower Bracket	C	BM15A
8602	31'2 1/4"	-25'11"	15' 3/4"	z	2264	2000	Hard Mount Lower Bracket	C	BP34A
8603	31'2 1/4"	-25'10"	16'11 3/4"	y	2264	2000	Hard Mount Upper Bracket	C	BN60A
8604	31'2 1/4"	-25'20 3/4"	17'0"	z	2264	2000	Hard Mount Upper Bracket	C	BN67A
8605	75'2"	-25'6 1/4"	15'2 1/2"	y	2264	2000	Shock Mount Lower Bracket	C	BY62A
8606	75'2"	-25'3 1/4"	15'10"	z	2264	2000	Shock Mount Lower Bracket	C	CA55A
8607	75'4"	-25'2 3/4"	15'9 1/4"	y	2264	2000	Shock Mount Lower Tank Gusset	C	BN71A
8608	75'4"	-25'3 1/4"	15'10"	z	2264	2000	Shock Mount Lower Tank Gusset	C	BF69A
8609	75'2"	-25'6"	17'2 3/4"	y	2264	2000	Shock Mount Upper Bracket	C	BN03A
8610	75'2"	-25'6 3/4"	17'3"	z	2264	2000	Shock Mount Upper Bracket	C	BP41A
8611	--	--	--	x	2264	2000	Platform Base	A	--

TABLE 5. MEASUREMENT LIST AS BUILT FOR TEST 1 (CONTINUED).

Meas. No.	As-Built Location			Sensitivity Axis	Transducer		Description	Company	Serial Number
	x	y	z		Model	Range (g)			
8612	--	--	--	y	2264	2000	Platform Base	A	--
8613	--	--	--	z	2264	2000	Platform Base	A	--
8614	--	--	--	y	2264	2000	Suspended Tank Base	A	--
8615	--	--	--	z	2260	250	Suspended Tank Base	A	--
8616	--	--	--	y	2262	100	Suspended Tank Top	A	--
8617	--	--	--	y	2264	2000	Detector Base	A	--
8618	--	--	--	z	2264	2000	Detector Base	A	--
8619	--	--	--	x	2260	250	Hard Mount Lower Gusset	C	(installed only for FCS and FCB shots)
8620	--	--	--	x	2260	250	Hard Mount Upper Gusset	C	(installed only for FCS and FCB shots)
8621	--	--	--	x	2260	250	Suspended Tank Bottom	A	(M/N 8615 250 g Accel. moved to x-axis)

TABLE 5. MEASUREMENT LIST AS BUILT FOR TEST 1 (CONCLUDED).

Meas. No.	As-Built Location			Sensitivity Axis	Transducer		Description	Company	Serial Number
	x	y	z		Model	Range (g)			
8622	--	--	--	x	2262	200	Detector Base	A	(installed only for FCS and FCB shots)
8623	--	--	--	x	2262	200	Platform Base	A	(M/N 8611 2 kg Accel. installed for FCB and FCS shots)
8624	33'3 1/4"	-33'9 3/8"	93 5/8"	y	2264	2000	Detector Mounting Plate	C	BN75A
8625	33'3 1/4"	-33'9"	94"	z	2264	2000	Detector Mounting Plate	C	DD69A
8626	82'7 3/4"	34'2"	49 1/8"	y	2264	2000	Control Box		BN74A
8627	82'7 3/4"	34'2 5/8"	50 1/8"	z	2264	2000	Control Box		BL13A
8628	--	--	--	x	2260	250	Control Box		(installed only for FCS and FCB shots)

2. Test 2 : ARS-1

The changes in instrumentation from the first to the second tests are presented in Table 6. Some gages and the cameras were deleted and measurement numbers 8614 and 8615 were added.

The as-built locations and serial numbers of the additional gages are presented in Table 7. The information from Test 1 for the gages common between Tests 1 and 2 remained unchanged for Test 2.

3. Test 3 : FLB-1

The instrumentation used in Test 3 is that defined in Table 8.

The as-built locations of instrumentation used in Test 3 are presented in Table 9.

The identification of specific gage information versus measurement number for Test 3 is presented in Table 10.

4. Test 4 : ARS-2

The instrumentation used in Test 4 is that defined in Table 11.

The identification of specific gage information versus measurement number for Test 4 is presented in Table 12. The as-built locations of instrumentation used in Test 4 are presented in Table 13.

TABLE 6. INSTRUMENTATION FOR TEST 2.

Company	Description	Gages for Second Test	Total Number of gages
	Delete 2 cameras; i.e., no filming <sup>a</sup>	None	0
C	Hard Mount <sup>b</sup> : Delete z gages and lower y	8603y	
C	AVM Mount <sup>c</sup> : Same	8605y, 8606z, 8607y, 8608z, 8609y, 8610z	
A	CB Mount <sup>d</sup> : Delete x gage	8626y	
A	Suspension Mount : Add lower y and z gages	8614y, 8615z	
TOTAL			10

<sup>a</sup> Filming in first test was successful.

<sup>b</sup> Upper data have more content.

<sup>c</sup> This mount is in line.

<sup>d</sup> Good data were acquired; this mount is in line.

<sup>e</sup> This mount is mostly uncoupled from the wall; it will provide data on blast effects on the side opposite the blast.

Notes: A = Company 'A'  
C = Company 'C'  
CB = Control Box

TABLE 7. AS-BUILT INSTRUMENTATION FOR TEST 2.

Meas. No.	As-Built Location			Sensitivity Axis	Transducer		Description	Company	Serial Number
	x	y	z		Model	Range (g)			
8614	42'6 1/2"	30'1"	8'11 1/4"	y	2264	2000	Suspended Tank Base	A	BN80A
8615	42'6 1/2"	30'3 1/2"	9' 3/4"	z	2260	250	Suspended Tank Base	A	AR79F

TABLE 8. INSTRUMENTATION FOR TEST 3.

Company	Description	Gages for Third Test	Number of Gages	Type of Gages
C	Hard Mount, Upper Bracket	8603y	1	Accelerometers
A	Tray Mount, 8612y, 8613z	8612y, 8613z	2	Accelerometers
A	Suspension Mount, tank base	8614y, 8615z	2	Accelerometers
	tank top	8616y	1	Accelerometers
A	Detector, base	8617y, 8618z	2	Accelerometers
A	Control box (switch from control box)	8626y, 8627z	2	Accelerometers
Subtotal			10	
A	Suspension Mount, cable strain link	3905z	1	Strain gage
A	Manifold	3901z, 3902y	2	Strain gage
Subtotal			3	
TOTAL			13	

TABLE 9. AS-BUILT GAGE LOCATIONS FOR TEST 3.

Meas. No.	As-Built Location			Sensitivity Axis	Transducer Model	Transducer Range (g)	Description	Company
	x	y	z					
8601				y	2264	2000	Hard Mount Lower Bracket	C
8602				z	2264	2000	Hard Mount Lower Bracket	C
8603	31'2 1/4"	-25'10"	16'11 3/4"	y	2264	2000	Hard Mount Upper Bracket	C
8604				z	2264	2000	Hard Mount Upper Bracket	C
8605				y	2264	2000	Shock Mount Lower Bracket	C
8606				z	2264	2000	Shock Mount Lower Bracket	C
8607				y	2264	2000	Shock Mount Lower Tank Gusset	C
8608				z	2264	2000	Shock Mount Lower Tank Gusset	C
8609				y	2264	2000	Shock Mount Upper Bracket	C
8610				z	2264	2000	Shock Mount Upper Bracket	C

TABLE 9. AS-BUILT GAGE LOCATIONS FOR TEST 3 (CONCLUDED).

Meas. No.	As-Built Location			Sensitivity Axis	Model	Transducer Range (g)	Description	Company
	x	y	z					
8611				x	2264	2000	Platform Base	A
8612	69'8"	31'4 1/4"	9'11 1/4"	y	2264	2000	Platform Base	A
8613	69'8"	31'11 1/4"	10'3"	z	2264	2000	Platform Base	A
8614	42'6 1/2"	30'1"	8'11 1/4"	y	2264	2000	Suspended Tank Base	A
8615	42'6 1/2"	30'2 1/2"	9' 3/4"	z	2260	250	Suspended Tank Base	A
8616	42'6 1/2"	30'2"	12'5 3/4"	y	2262	100	Suspended Tank Top	A
8617	74'3 3/4"	32'9 1/2"	9'10"	y	2264	2000	Detector Base	A
8618	74'5 5/8"	32'8"	10'	z	2264	2000	Detector Base	A
8626	83'5"	34'7 1/2"	4'10"	y	2264	2000	Control Box	A
8627	83'5"	34' 1/2"	5'1 3/4"	z	2264	2000	Control Box	A
3901	73'5 3/4"	33'3 1/2"	10'4"	z	2264	2000	Manifold-Platform End	A
3902	73'5 3/4"	33'3 1/2"	10'4"	y	2264	2000	Manifold-Platform End	A
3905	42'2 1/2"	31'	13'4"	z	2264	2000	Cable Link	A

Notes: Change 8627z-250g to BY62A2000 g (bad accelerometer).

TABLE 10. AS-BUILT GAGE IDENTIFICATION FOR TEST 3.

Meas. No.	Company	Description	Sensitivity Axis	Gage Type and Range (g)	SN	Pred Cal	B.E. (%)
8603	C	HDUpper Bracket	y	2262-100	JW24	30 g	50
8612	A	Platform Base	y	2264-2000	BF69A	250 g	50
8613	A	Platform Base	z	2262-250	AQ33F	150 g	50
8614	A	Suspended Base	y	2262-200	LD74	85 g	50
8615	A	Suspended Base	z	2262-250	FG12	60 g	50
8616	A	Suspended Top	y	2262-250	AR45F	75 g	50
8617	A	Detector Base	y	2262-250	AS43F	120 g	50
8618	A	Detector Base	z	2262-200	LD68	95 g	50
8626	A	Control Box	y	2262-250	AS51F	95 g	50
8627	A	Control Box	z	<sup>a</sup> 2262-2000	BY62A	80 g	50
3901	A	Manifold Vertical Plane	z	Strain		3000 ue	40
3902	A	Manifold Horizontal Plane	y	Strain		3000 ue	40
3905	A	Suspended Cable	z	Force Link	FL1	2400 lb	50

<sup>a</sup> 2262-100 (JL53) and 2262-250 (AS49F) malfunctioned.

TABLE 11. INSTRUMENTATION FOR TEST 4.

Company	Description	Measurement No.	Total Gages
C	Hard Mount, lower bracket from wall	8601y, 8602z	2 accelerometers
C	Detector	8624y, 8625z	2 accelerometers
A	Control Box	8626y, 8627z	2 accelerometers

Notes: All gages for the fourth test will be placed on the bases (wall mounted) of all equipment, not on the equipment itself.

Additional instrumentation may be required per discussions about existing data.

Move the Company 'C' Hard Mount with loaded cylinder (chem-bolted) and the GL Detector (welded) to be as directly in line with the blast as possible.

TABLE 12. AS-BUILT GAGE IDENTIFICATION FOR TEST 4.

Meas. No.	Company	Description	Sensi- tivity Axis	Gage Type and Range (g)	SN	Pred Cal	B.E. (%)	Mounted Resonance	Frequency Response	Damping Factor
8601	C	HM	y	2260-250	AQ33F	100 g	50	14 KHz	2 KHz	0.01
8602	C	HM	z	2260-250	AS43F	100 g	50	14 KHz	2 KHz	0.01
8624	C	Detector	y	2262-200	LD74	70 g	50	7,000 Hz	3,000 Hz	0.70
8625	C	Detector	z	2262-200	FG12	70 g	50	7,000 Hz	3,000 Hz	0.70
8626	A	Control Box	y	2262-200	LD68	70 g	50	7,000 Hz	3,000 Hz	0.70
8627	A	Control Box	y	<sup>a</sup> 2262-100	JW24	60 g	50	5,000 Hz	2,000 Hz	0.70
8617	Redundant to 8601			2264-2000	BF69A	100 g	50	30,000 Hz	5,000 KHz	1002.00
8618	Redundant to 8602			2264-2000	BN76A	100 g	50	30,000 Hz	5,000 KHz	1002.00

<sup>a</sup> May use 2262-200 if this gage is not available.

TABLE 13. AS-BUILT GAGE LOCATIONS FOR TEST 4.

Meas. No.	Company	Description	Sensitivity Axis	As-Built Location		
				x	y	z
8601	C	Hard Mount	y	33'5 3/4"	29'7 1/2"	14'11 1/2"
8602	C	Hard Mount	z	33'5 3/4"	29'8"	15'
8624	C	Detector	y	21'8 1/2"	34'2"	8'
8625	C	Detector	z	21'8 1/2"	34'2 1/2"	8' 1/2"
8626	A	Control Box	y	47' 6"	34'10"	4'8 1/2"
8627	A	Control Box	z	47' 6"	35'2"	5'5 1/4"
8617		Redundant to 8601	y	33'5 3/4"	29'9 1/2"	14'11 3/4"
8618		Redundant to 8602	z	33'5 3/4"	29'10"	15'

## SECTION VI HAS-FPS SHOCK TEST SPECIFICATION

### A. INTRODUCTION

The instrumentation recording for all four aircraft shelter tests was done by the Air Force Weapons Laboratory (AFWL). AFWL also did the analog to digital conversion of the test data for each test. After the test series was completed, the New Mexico Engineering Research Institute (NMERI) corrected the data for the HAS-FPS Program. AFWL/SC provided NMERI with digital tapes of the test data.

The raw and corrected data for the HAS-FPS Program are given in Reference 9. The original data from the test series are classified. However, unclassified digital tapes were created from the classified tapes to permit processing on non-Tempest computer systems. The unclassified tape was created by stripping all classified gage header information and replacing each measurement number with a new coded measurement number. The measurement numbers on the raw and corrected data plots in Reference 9 are coded measurement numbers. These numbers may be correlated to the true measurement numbers using the classified measurement number cross reference table in Reference 10.

Reference 9 presents the response characteristics of the gages used in the test series, the approach taken in selecting the filtering and sampling rates, the procedures and techniques used to correct the data, and a detailed analysis of the quality of the raw and corrected data. A hard copy of the raw and corrected data plots, at various time scales, are given in the appendixes. The shock response spectra tripartite plots are also presented in these appendixes.

All HAS-FPS equipment survived the shock effects introduced by the detonation of the conventional weapon in each aircraft shelter test. No structural, mechanical, or electrical failures were noticed upon posttest inspection of the equipment. Not all equipment was subjected to the same shock environment because of the different types of weapons and the different weapon and equipment locations. Data on the severity of the shock motions measured on the equipment are presented in Reference 9 in the form of pseudovelocity shock response spectra (SRS) curves.

## B. HAS-FPS EQUIPMENT TEST SPECIFICATION

### 1. Environment for Test Specification

A complete knowledge of the shock environment in which the HAS-FPS may have to survive is not available to the test engineer. The main reason for this is that the shock environment is governed by many random factors that are not known ahead of their occurrence. In this sense, the shock environment is random. When performing a dynamic test, however, either a deterministic or a random input may be used to meet the test requirements. The test input should be developed to have the required characteristics of (1) intensity, (2) frequency content, (3) decay rate, and (4) phasing (for proper dynamic interactions in the case of multiple inputs). Usually these parameters are chosen to represent the most severe environment that the equipment may reasonably be expected to survive in its design life. If these requirements are satisfied, it is not necessary for the test environment to be identical to the expected environment.

In dynamic testing or analysis, the excitation input can be represented in several ways. The most appropriate for the current case is the shock response spectrum (SRS) method. In dynamic testing or analysis the SRS curves are employed to specify the dynamic environment to which the equipment is to be subjected. This specified SRS is known as the required shock response spectrum. In order to satisfy the test specification conservatively, the shock response spectrum of the test input, known as the test shock response spectrum, should envelop the required shock response spectrum. Note that when shock response spectra are used to represent the test input signal in testing, the damping value used in computing the shock response spectrum has no bearing on the damping that is present in the test object. The spectrum is merely a representation of the input signal.

The required shock response spectrum for the HAS-FPS equipment to be mounted on the arch wall is the 5 percent damped spectrum given in Figure 28. The required spectrum applies to both the vertical and horizontal axes of the equipment as defined by the mounted configuration in the aircraft shelter. The test excitation shall be generated with multifrequency excitation inputs. The 5 percent damped test shock response spectrum, which is felt by the equipment mounts, shall envelop the 5 percent damped required shock response spectrum given in Figure 28. The amplitudes of the test excitation input shall be equal to or greater than the zero period acceleration of the required shock response spectrum, unless other amplitudes can be otherwise justified.

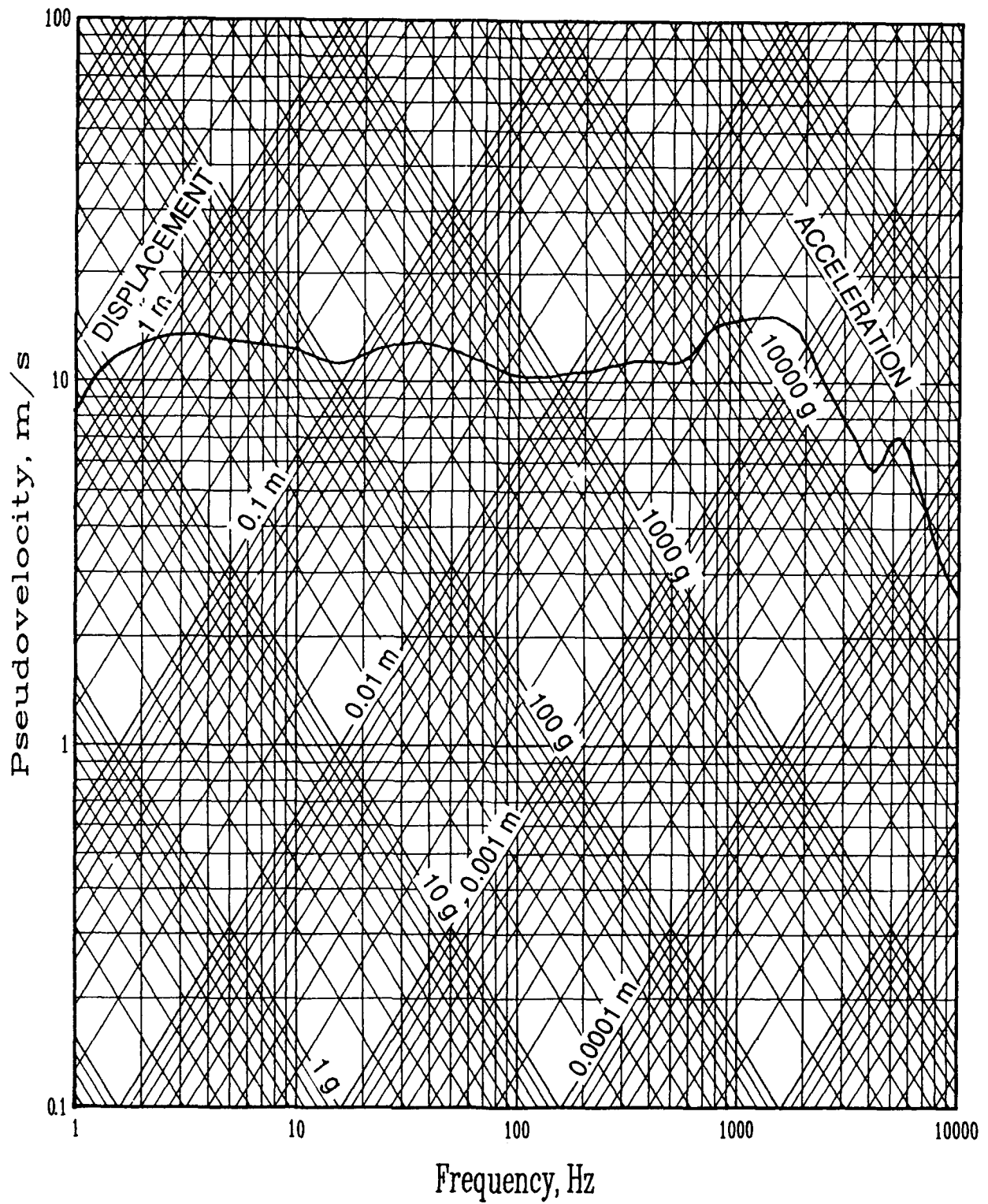

Figure 28. Pseudovelocity Shock Response Spectrum for HAS-FPS Equipment, 5 Percent Damped.

The required shock response spectrum in Figure 28 was developed by enveloping shock response spectra derived from acceleration measurements on the arch wall and those on the mounting fixture of FPS equipment. It would, of course, be desirable to have additional acceleration measurements on the arch wall to derive a more refined and perhaps less conservative required shock response spectrum. Further definition of the shock environment at the arch wall could reveal that there is sufficient difference in the severity of the shock motions to specify a different required shock response spectrum at low elevations on the wall versus higher elevations on the wall, or a different required spectrum for the horizontal and vertical directions.

It should be noted that the required spectrum in Figure 28 applies to the case of an unbermed arch wall. Therefore, a different required spectrum may be desirable for aircraft shelters whose walls are bermed. Finally, the required spectrum in Figure 28 was derived from shock response spectra that are based on the soil conditions at the test site. Different soil conditions could result in more severe shock motions at the arch wall than those measured at the Utah test site. It may be necessary to adjust the required shock response spectrum to account for different soil conditions.

## 2. Equipment Shock Qualification Procedures

Shock qualification by testing is appropriate for complex equipment. In such cases, equipment size is a limiting factor. Qualification by analysis is suitable for large equipment that is relatively simple to model. Often both testing and analysis are needed in the qualification of a piece of equipment. Shock qualification by testing is accomplished by applying a dynamic excitation by means of a shaker to the equipment, which is suitably mounted to a test table, and monitoring the structural integrity and functional operability of the equipment. Special attention must be given to the development of the shock test environment, mounting features, the operability variables that should be monitored, the method of monitoring structural integrity and functional operability, and the acceptance criteria used to decide qualification.

The first step in a qualification program is the preparation of a qualification procedure. The qualification procedure is prepared by the test laboratory (contractor). This document describes in sufficient detail a number of items relevant to the test: specifically, the tests that will be conducted on the test object; pretest procedures; the nature of the test input excitations and the method of generating these signals; inspection and response monitoring procedures during testing; definitions of equipment malfunction; and qualification criteria. If analysis is also used in the qualification program, the analytical methods and the computer programs that will be used should be described in the qualification procedure.

Before the qualification tests are conducted, the qualification procedure is submitted to the purchaser for approval. The purchaser normally hires a reviewer (consultant) to determine whether the qualification procedure satisfies the requirements of both the agency that mandated the qualification tests and the purchaser. The qualification test is performed according to the approved qualification procedure. The test laboratory prepares a qualification report, which is sent to the purchaser for evaluation. The purchaser might obtain the services of a consultant to review the qualification report. The report might have to be revised or the tests repeated before the final decision is made on the qualification of the equipment.

## SECTION VII CONCLUSION

The goal of this project was successfully attained by obtaining response data for the semihardened aircraft shelter and the HAS-FPS hardware subjected as integral systems to the conventional weapons threat and then formulating the performance requirements for specification.

The full-scale fire protection system equipment previously used in the HAS-FPS fire detection and suppression tests was installed in a full-scale Third Generation semihardened aircraft shelter, a mock-up of which was constructed at the Utah Test and Training Range. The shelter and hardware were instrumented with accelerometers and strain gages. Other instrumentation included displacement indicators, time of arrival gages, and camera coverage. Various mounting schemes were used to envelop the range of integrity and potential styles for mounting. All mounts performed satisfactorily except for the cylinder that was not well secured in all directions. The scheme for securing stiff supports of heavy suppression cylinders to the shelter should be by chemical bolt into the shelter concrete wall. Other flexible mounts such as the wire rope with springs can be welded to the shelter liner. All lightweight hardware such as detectors, piping, and control electronics can be welded to the wall. Data are provided for further structural analyses. Additionally, the final choice of the mounts for all equipment shall be subjected to testing that uses the derived required shock response spectrum to validate the structural and performance reliabilities of the mounts and the equipment as a system.

The required shock response spectrum for the HAS-FPS equipment to be mounted on the shelter arch wall is the 5 percent damped spectrum given in Figure 28. The excitation tests shall be generated with multifrequency excitation inputs to envelop this spectrum. The amplitudes of the test excitation input shall be equal to or greater than the zero period acceleration of the required shock response spectrum unless other amplitudes can be otherwise justified. Procedures for a qualification test program were presented to ensure validation of the first articles.

The required shock response spectrum in Figure 28 applies to the case of an unbermed arch wall. Therefore, a different required spectrum may be desirable for aircraft shelters with bermed walls. Finally, the required spectrum in Figure 28 was derived from shock response spectra that are based on the soil conditions at the test site. Different soil conditions could result in more severe shock motions at the arch wall than those measured at the Utah test site. It may be necessary to adjust the required shock response spectrum to account for different soil conditions.

## REFERENCES

1. Zallen, Dennis M., Morehouse, E. T., Dees, B. R., Walker, J. L., and Campbell, P., **Fire Protection System for Hardened Aircraft Shelters**, ESL-TR-86-13, Engineering and Services Laboratory, Air Force Engineering and Services Center, Tyndall AFB, Florida, October 1987. UNCLASSIFIED
2. Military Standard, MIL-STD-810C, Environmental Test Methods, 10 March 1975.
3. "Response of Semihardened Aircraft Shelter Fire Protection System (HAS-FPS) to Bomb Blast Loading," Subtask Statement 3.30, Contract No. F29601-84-C-0080, Civil Engineering Research Facility, Air Force Weapons Laboratory, KAFB, New Mexico.
4. "Semihardened Construction in Aircraft Shelter Upgrades," Subtask Statement 2.17, Contract No. F29601-84-C-0080, Civil Engineering Research Facility, Air Force Weapons Laboratory, KAFB, New Mexico.
5. Skaggs, Timothy M., **Semihardened Construction in Aircraft Shelter Upgrades Construction Report**, NMERI WA2-37 (S.S. 2.06), New Mexico Engineering Research Institute, University of New Mexico, Albuquerque, New Mexico, January 1987. UNCLASSIFIED
6. "Aircraft Shelter Upgrades Program," Personal Communication, Dr. Dennis M. Zallen, UNM/NMERI/CERF and Captain Dan L. Gullett, AFWL/NTEO, dated 25 August 1987.
7. Zallen, Dennis M., **Response of Semihardened Aircraft Shelter Fire Protection System (HAS-FPS) to Bomb Blast Loading: Test Plan**, NMERI WA3-47 (S.S. 3.30), Contract No. F29601-84-C-0080, New Mexico Engineering Research Institute, University of New Mexico, Albuquerque, New Mexico, September 1987. UNCLASSIFIED
8. Zallen, D. M., Watson, J. D. and Walker, J. L., **Response of Semihardened Aircraft Shelter Fire Protection System (HAS-FPS) to Bomb Blast Loading (BBI): Test Report**, NMERI WA3-68 (S.S. 3.30), Contract No. F29601-84-C-0080, New Mexico Engineering Research Institute, University of New Mexico, Albuquerque, New Mexico, August 1988. UNCLASSIFIED
9. Marquis, J. P., **Response of Semihardened Aircraft Shelter Fire Protection System (HAS-FPS) to Bomb Blast Loading: Data Analysis Report**, ESL-TR-88-28, Engineering and Services Laboratory, Air Force Engineering and Services Center, Tyndall AFB, Florida, June 1989. UNCLASSIFIED
10. Marquis, J. P., and Zallen, D. M., **Response of Semihardened Aircraft Shelter Fire Protection System (HAS-FPS) to Bomb Blast Loading: Classified Measurement Number Cross Reference Table (U)**, NMERI WA3-77 (S.S. 3.30), Contract No. F29601-84-C-0080, New Mexico Engineering Research Institute, University of New Mexico, Albuquerque, New Mexico, June 1989. SECRET