

DND FILE COPY

①

AD _____

THE ACUTE INHALATION TOXICITY OF PYROLYSIS PRODUCTS OF HALON 1301

Subtitle: Exercise Potentiation of Expression of Lung Injury
Induced by Compounds 1 and 2

AD-A231 615

FINAL REPORT

BRUCE E. LEHNERT
DOUGLAS M. STAVERT

OCTOBER 30, 1990

Supported by

U.S. ARMY MEDICAL RESEARCH AND DEVELOPMENT COMMAND
Fort Detrick, Frederick, Maryland 21702-5012

Project Order No. 87PP7832

Los Alamos National Laboratory
Los Alamos, New Mexico 87545

DTIC
SELECTED
FEB 06 1991
S B D

Approved for public release; distribution unlimited

The findings in this report are not to be construed as an
official Department of the Army position unless so designated
by other authorized documents

91 2 04 083

**Best
Available
Copy**

REPORT DOCUMENTATION PAGE

Form Approved
OMB No. 0704-0188

1a. REPORT SECURITY CLASSIFICATION Unclassified			1b. RESTRICTIVE MARKINGS			
2a. SECURITY CLASSIFICATION AUTHORITY			3. DISTRIBUTION/AVAILABILITY OF REPORT Approved for public release; distribution unlimited			
2b. DECLASSIFICATION/DOWNGRADING SCHEDULE						
4. PERFORMING ORGANIZATION REPORT NUMBER(S)			5. MONITORING ORGANIZATION REPORT NUMBER(S)			
6a. NAME OF PERFORMING ORGANIZATION Los Alamos National Laboratory		6b. OFFICE SYMBOL (if applicable)	7a. NAME OF MONITORING ORGANIZATION			
6c. ADDRESS (City, State, and ZIP Code) Los Alamos, New Mexico 87545			7b. ADDRESS (City, State, and ZIP Code)			
8a. NAME OF FUNDING/SPONSORING ORGANIZATION U.S. Army Medical Research & Development Command		8b. OFFICE SYMBOL (if applicable)	9. PROCUREMENT INSTRUMENT IDENTIFICATION NUMBER Project Order No. 87PP7832			
8c. ADDRESS (City, State, and ZIP Code) Fort Detrick Frederick, Maryland 21702-5012			10. SOURCE OF FUNDING NUMBERS			
			PROGRAM ELEMENT NO. 62787A	PROJECT NO. 3M1-62787A875	TASK NO. AA	WORK UNIT ACCESSION NO. 081
11. TITLE (Include Security Classification) (U) The Acute Inhalation Toxicity of Pyrolysis Products of Halon 1301						
12. PERSONAL AUTHOR(S) Bruce E. Lehnert and Douglas M. Stavert						
13a. TYPE OF REPORT Final		13b. TIME COVERED FROM: 4/1/87 TO 9/30/90		14. DATE OF REPORT (Year, Month, Day) 1990 October 30	15. PAGE COUNT 101	
16. SUPPLEMENTARY NOTATION Subtitle: Exercise Potentiation of Expression of Lung Injury Induced by Compounds 1 and 2						
17. COSATI CODES			18. SUBJECT TERMS (Continue on reverse if necessary and identify by block number) RA 3; Toxicology; Gases; Acute Inhalation; Halon 1301; Pyrolysis Products			
FIELD	GROUP	SUB-GROUP				
06	04					
06	11					
19. ABSTRACT (Continue on reverse if necessary and identify by block number)						
20. DISTRIBUTION/AVAILABILITY OF ABSTRACT <input type="checkbox"/> UNCLASSIFIED/UNLIMITED <input checked="" type="checkbox"/> SAME AS RPT. <input type="checkbox"/> DTIC USERS			21. ABSTRACT SECURITY CLASSIFICATION Unclassified			
22a. NAME OF RESPONSIBLE INDIVIDUAL Mary Frances Bestian			22b. TELEPHONE (Include Area Code) 301-663-7325		22c. OFFICE SYMBOL SGRD-RM1-S	

FOREWORD

In conducting research using animals, the investigator(s) adhered to the "Guide for the Care and Use of Laboratory Animals," prepared by the Committee on Care and Use of Laboratory Animals of the Institute of Laboratory Animal Resources Commission on Life Sciences, National Research Council (DHHS, PHS, NIH Publication No. 86-23, Revised 1985).

Citations of commercial organizations and trade names in this report do not constitute an official Department of the Army endorsement or approval of the products or services of these organizations.



Accession For	
NTIS GRA&I	<input checked="" type="checkbox"/>
DTIC TAB	<input type="checkbox"/>
Unannounced	<input type="checkbox"/>
Justification	
By _____	
Distribution/	
Availability Codes	
Dist	Avail and/or Special
A-1	

Introduction

This final report summarizes investigations that have focused on the lower respiratory tract toxicities of inhaled perfluoroisobutylene (PFIB/Compound 1) and bis(trifluoromethyl)disulfide (TFD/Compound 2), and it describes how the injurious effects of these compounds may be enhanced by post-exposure exercise and/or result in a reduction in work performance capacity. The major objectives of the project were: 1) to determine if the expression of lung injury induced by PFIB and TFD can be increased in severity by post-exposure exercise using lung gravimetric and histopathologic criteria as endpoints, 2) to characterize the post-exposure period of time during which the expression of PFIB- and TFD-induced lung injury can be potentiated by exercise, i.e., the "window of susceptibility" 3) to determine if early post-exposure exercise performed during the "window of susceptibility" can extend the post-exposure period of time within which exercise can potentiate the expression of lung injury caused by inhaling PFIB and TFD, and 4) to examine how the inhalation of PFIB and TFD may affect work performance capacity.

Prior to experimentally addressing the above objectives, a series of preliminary studies were performed using varying concentrations of inhaled PFIB and TFD to determine the magnitude and kinetic course of development of resulting lung injury as a function of exposure mass concentration. Information obtained in these initial studies was then used to select mass concentrations of PFIB and TFD to be used in the actual exercise potentiation and work performance incapacitation studies.

For the sake of clarity, this report is presented in two parts. Part I describes investigations involving PFIB, and Part II describes investigations that involved TFD. These two components of the project are then separately summarized in the Summary Statements section of the report.

PART I. PFIB STUDIES

Materials and Methods

Animal Use and Welfare. Adult, male Fischer 344 rats weighing between 250 and 280 gm were used in this study. The stock from which the animals were derived is categorized as "specific-pathogen-free, virus-free" by the producer (Harlan Sprague Dawley, Inc., Indianapolis, IN). Upon arrival to Los Alamos, the rats were housed two per cage in polycarbonate cages covered with spun polyester filters (DuPont #22 Spinbound Polyester Filter, E.E. DuPont Co., Wilmington, DE) in an animal facility approved by the American Association for Accreditation of Laboratory Animal Care. The cages were maintained in air conditioned rooms that receive filtered air. Water and standard laboratory rat chow (autoclaved) were provided *ad libitum*. Prior to entry into any experimental study, the rats were maintained for a 2 week period in order to acclimate them to the laboratory facility, as well as to observe them for evidence of disease. In this latter regard, representative animals randomly selected from each shipment group were sacrificed with lethal I.P. Injections of pentobarbital sodium, blood serum was obtained for antibody titer levels, and their lungs were examined for disease. Animal sera were tested by Microbiological Associates (Bethesda, MD) for Reo 3, GDVII, KRV, H-1, M.AD, LCM, PVM, Sendai, and RCA. All sera tested over the last several years have been negative for the above infections, including sera obtained from animals maintained in our facility for over 3 months.

The Fischer-344 rat was selected as the animal model for the proposed studies for several reasons. First, the Fischer-344 rat is now widely accepted as a standard animal model for toxicological studies. Second, the use of a small animal model such as the rat allows studies to be performed with sufficient animal numbers for suitable statistical analyses. Third, the responses in the respiratory tracts of the rat and the human are similar following exposure to a variety of toxic substances.

The protocols employed in this study were reviewed and approved by the Los Alamos National Laboratory Animal Care and Use Committee. We also note that the conduct and reporting of these studies have been and are in accordance with the "Guide for the Care and Use of Laboratory Animals", prepared by the Committee on Care and Use of Laboratory Animals of the Institute of Laboratory Animal Resources, National Council (DHEW Publication No. [NIH] 85-23, 1985).

Of relevance to the project, the body weights of the animals used in a given set of studies involving air and PFIB exposures were closely matched so their baseline lung gravimetric values would be virtually identical at the time of exposure (Tillery and Lehnert, 1986).

Overview of Objectives and Approaches. Preliminary range finding studies were undertaken to assess the inhaled concentration-response characteristics of lung injury that occur as of 24 hr after

exposing groups of rats to differing concentrations of PFIB. In these studies, rats were exposed to either filtered air, 50 mg/M³, 83 mg/M³, 90 mg/M³, 100 mg/M³ or 110 mg/M³ PFIB for a duration of 10 min, Table 1. These animals were then sacrificed 24 hr after the exposures and their lungs were gravimetrically measured and prepared for histopathologic analyses. Further studies of the kinetics of PFIB-induced lung injury were performed with the goal being to select a mass concentration of PFIB for subsequent use in the exercise potentiation and work performance degradation investigations, as well as to characterize the kinetics of onset of PFIB-induced lung injury after inhalation of different PFIB concentrations. In these investigations, rats were exposed to either control air, 90 mg/M³, 100 mg/M³, 110 mg/M³ or 200 mg/M³ PFIB for 10 min. Lung injury was assessed at various times after exposure, as indicated in Table 1, using lung gravimetric and histopathologic endpoints (to be described). For the exercise potentiation component of this study, animals were exposed to 100 mg/M³ PFIB for 10 min and exercised at various times after exposure, Table 1, and they were sacrificed either shortly thereafter or after a more extended period of time depending on the experimental question being addressed. Control groups consisted of rats that were exposed to PFIB and then allowed to rest until sacrifice. During the exercise bout, metabolic data was measured as described below. Additional studies were also performed to access various further aspects of the lung injury caused by PFIB inhalation. These ancillary investigations included an electron microscopy study, and a free cell response and lung lavage fluid constituent study.

Atmosphere Generation and Characterization. An exposure system for delivering up to 200 mg/M³ of perfluoroisobutylene (PFIB) to laboratory rats was designed and fabricated, Figure 1. The exposure system for PFIB exposures consisted of an atmosphere generator, delivery tubing and valves, animal exposure tubes, and a charcoal absorbing bed. The exposure system materials were composed of Teflon[®] or stainless steel (SS). PFIB was purchased from Fluoro Corp, Newport, TN, and it was stored in a stainless steel cylinder at its vapor pressure (~4 psig at the altitude of the Los Alamos National Laboratory). A SS micrometering valve was attached directly to the storage cylinder. A 1 ml gas-tight syringe (Hamilton, Reno, NV) was attached to this valve via microbore Teflon[®] tubing. The micrometering function and microbore tubing resistance provided for precisely controlled filling of the syringe and prevented overfilling and possible escape of neat atmospheres. The syringe was placed into a syringe pump and it was attached to the dilution air manifold via Teflon[®] swagelock type fittings, Figure 1. HEPA-filtered dilution air was piped into a glove box from an external oil-less air compressor, and it was metered via a mass flow-controller (Matheson, La Porte, TX) to provide a constant 2 to 3 liter·min⁻¹ air flow rate through the exposure system. Exposure atmosphere generation began with the starting of the syringe pump, which was capable of delivering up to 0.024 ml·min⁻¹ of neat agent into the dilution airstream to produce the maximal exposure concentration of 200 mg PFIB/M³. Downstream of the mixing manifold, a Teflon[®] mixing chamber consisting of a series of internal baffles assured

PFIB EXPOSURE MATRIX		
PFIB CONCENTRATION-RESPONSE STUDIES		
PFIB Nominal Exposure Concentration		Post-Exposure Sacrifice Times (Hr)
50 mg/M ³		24
83 mg/M ³		24
90 mg/M ³		24
100 mg/M ³		24
110 mg/M ³		24
PFIB KINETIC STUDIES		
PFIB Nominal Exposure Concentration		Post-Exposure Sacrifice Times (Hr)
90 mg/M ³		1,8,24,48,72
100 mg/M ³		1,8,10,11,12,18,24,48,72
110 mg/M ³		1,3,5,8,24
200 mg/M ³		1,3
PFIB EXERCISE STUDIES		
PFIB Nominal Exposure Concentration	Post-Exposure Exercise Times	Post-Exposure Sacrifice Times (Hr)
100 mg/M ³	0 Hr	1
100 mg/M ³	6 Hr	8
100 mg/M ³	9 Hr	10
100 mg/M ³	10 Hr	11
100 mg/M ³	17 Hr	18
100 mg/M ³	23 Hr	24
100 mg/M ³	9 Hr	24
100 mg/M ³	9 & 23 Hr	24
100 mg/M ³	47 Hr	48

Table 1. Experimental exposure matrix for the PFIB studies.

GLOVE BOX ENCLOSURE

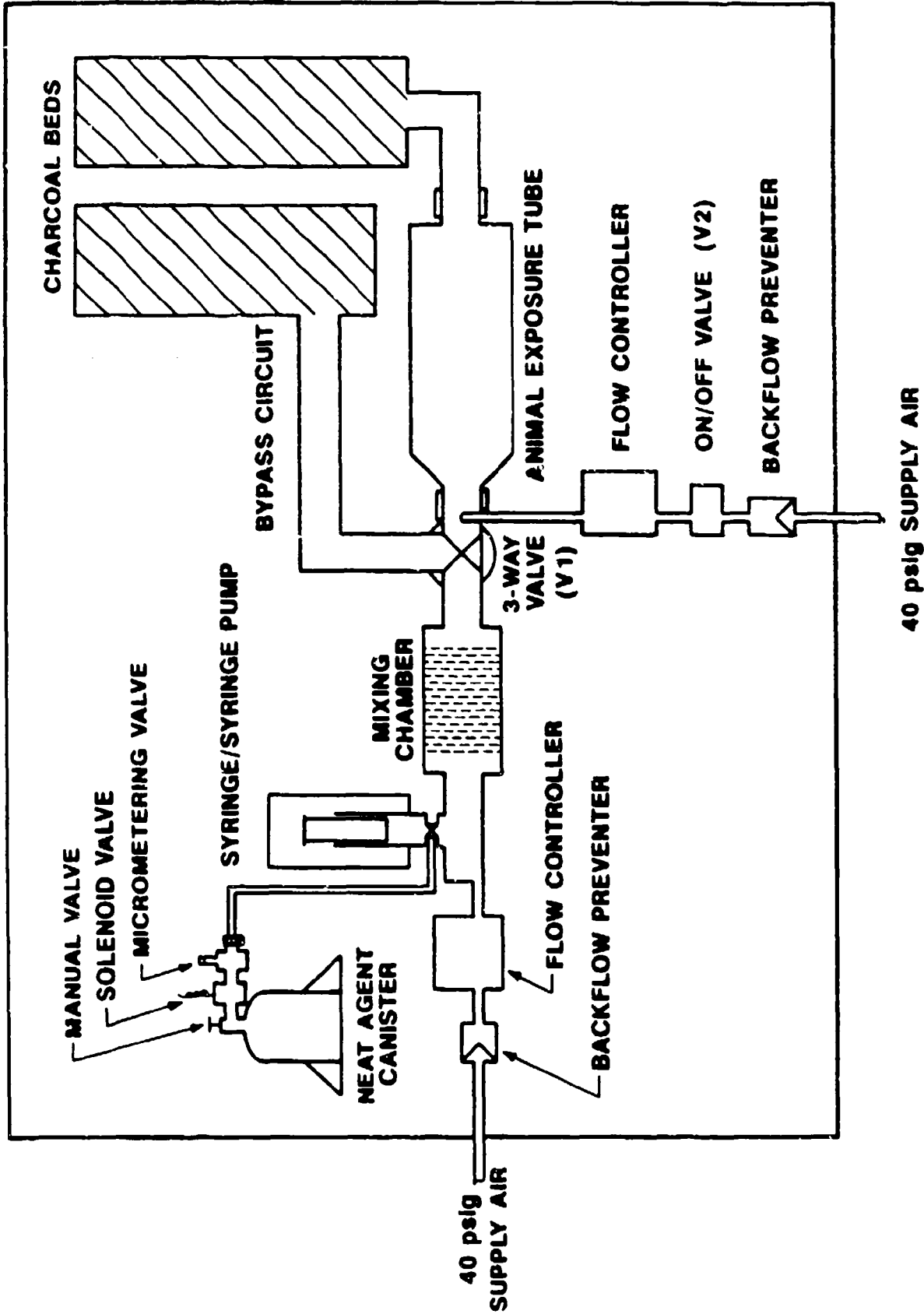

Figure 1. Perfluoroisobutylene (PFIB) atmosphere exposure system. The system in contact with PFIB is Teflon® or glass. Rats are exposed within whole body exposure tubes.

complete gas mixing before the exposure atmospheres were delivered to the animals. The exposure airstream was routed through a valve (V1) before delivery to the animal exposure tube. Valve V1 was a large bore Teflon[®] 3-way valve, and when pneumatically actuated with another valve (V2), it provided a means for the exposure atmosphere to by-pass the animal exposure tube while simultaneously delivering clean fresh air to an animal in the exposure tube. This allowed for the safe installation and removal of the animal exposure tubes as described later. Valve V2 was a flow control valve with solenoid ON-OFF features. It was operated from outside the glovebox and it was connected to the KIVA HEPA-filtered oil-less compressed air. Downstream from the animal exposure tube and bypass circuit, a charcoal absorption tower captured the exposure atmosphere. The exposure system was designed to work at atmospheric pressure of slightly positive pressure (<0.1 cm H₂O) relative to the glovebox in which it was contained while additionally being incapable of over-pressurization.

Measurement of the exposure atmospheres by gas chromatography occurred from ports located prior to the animal holding tube. Analysis of the exposure atmosphere occurred every 30 seconds with discrete samples being passed through a dual-column gas chromatograph. The detector for the GC peaks was an electron capture detector (Model 140B, Valco Instruments) sensitive to 1 ppb PFIB. The carrier gas was argon/methane (90:10), which was passed through a heated catalytic purifier (Supelco, Inc.) designed to remove oxygen and water. Column and sample purge flows (10-20 cm³·min⁻¹) were controlled by pressure regulators and needle valves. Sample loops and chromatographic columns (0.5 and 1.0 mm x 3 mm O.D. Teflon[®] columns containing 80/100 mesh Chromosil 310, Supelco, Inc.) were contained within a heated (70° C) valve oven and attached directly to electrically actuated valves. A valve sequence programmer and solenoid valves automatically initiated sampling every 40 sec while venting the interfering peak of oxygen. Calibration of the GC occurred at the beginning and end of the exposure experiments by sampling calibration atmospheres formulated by injecting measured microliter samples of neat PFIB into a closed system of known volume (Miran 1A Infrared Gas Analyzer, Foxboro, South Norwalk, CT). Animals were exposed to the atmospheres in Teflon[®] animal exposure tubes for periods of 10 min. Once the desired atmospheres were established and diverted into the exposure atmosphere bypass circuit, Figure 1, animals were sealed into the animal exposure tubes and passed into the glovebox through an airlock. The animal exposure tubes were secured into the exposure system with swagelock type fittings. The atmosphere was directed to the animal holding tubes for exposure. After an exposure, fresh air was directed to the animal exposure tube for a period of 10 min or when air sampling via the GC indicated the absence of PFIB within the animal exposure tube. At this time, the animal exposure tube was disconnected from the exposure system and passed into the laboratory area via the airlock. Animals were then returned to their cages and provided food and water *ad libitum*.

Metabolic Measurements. Before use, rats were subjected to a 20 day training program designed to behaviorally and physically condition them to perform on a treadmill (Stavert et al, 1987a; Stavert et al,

1987b; Stavert and Lehnert, 1989). During the training program, the work intensities and durations of exercise were increased daily until the rats were capable of performing a "ramp" exercise protocol, Figure 2. Animals that were observed to be "non-runners" during the training sessions were eliminated from the studies. The "ramp" protocol began at a treadmill velocity of 10 M·min⁻¹. Every 30 sec the treadmill velocity was increased by 5 M·min⁻¹ up to a final velocity of 60 M·min⁻¹ (15% grade). Maintenance of running speed was encouraged by electro-shock stimulation delivered via a grid (Coulburn, Lehigh, PA) mounted behind the treadmill. Prior to the "ramp" runs, the rats performed a "familiarization run" consisting of two short runs (20 M·min⁻¹ for 3 min, 15% grade) separated by a 3 min rest period and finally followed by a 10 min rest period before initiation of the actual "ramp" protocol. Subsequent reference to "exercise" in the work performance and exercise potentiation components of this study includes the "familiarization run". Maximum oxygen consumption (VO_{2max}) attained during performance of the "ramp" protocol were measured as a metabolic index of work performance incapacitation because of its close association with endurance (Astrand and Rodahl, 1986). The treadmill used for the "ramp" protocol was contained in a metabolic chamber that provides the necessary means to measure oxygen consumption and carbon dioxide production as a rat exercises, Figure 3. Airflow from the chamber (14 L·min⁻¹) was dried (Silica Gel, J.T. Baker Chemical Co., Phillipsburg, NJ) and measured electronically using a pneumotachograph (Fleish No. 0, Gould Inc., Cleveland, OH) and a transducer (Validyne Engineering, Northridge, CA) that was calibrated spirometrically. Oxygen and carbon dioxide concentrations in the effluent airstream were measured with suitable analyzers (Ametek S-3A O₂ Analyzer, Ametek CD3A CO₂ Analyzer, Ametek, Pittsburg, PA) that were calibrated with primary gas standards (Matheson Gas, LaPorte, TX). Oxygen consumption and carbon dioxide production were calculated every 3 sec via a data acquisition and computer system (HP-3497A, Hewlett-Packard, Corvallis, OR) using the equations of Mautz (1985). Maximum oxygen consumption, defined as the plateau of oxygen consumption achieved with increasing work loads, was expressed as ml O₂/kg body weight·min⁻¹ following correction for standard temperature and pressure. As illustrated in Figure 4, the VO_{2max} values of animals performing the "ramp" protocol become satisfactorily stable and reproducible during the last several days of the 20 day training program. As also indicated in Figure 4, trained rats usually maximally consume oxygen within 4-5 min after the "ramp" protocol is initiated.

Animal Sacrifices, Lung Gravimetric Measurements, and Histopathology: Animals were deeply anesthetized with I.P. injections of 50 mg pentobarbital sodium. After exsanguination, the trachea and lungs were excised, and the heart, extrapulmonary mediastinal tissue, and the esophagus were removed. The lung was blotted dry and weighed (Lung Wet Weight, LWW). The bronchus leading to the right cranial lobe (RCL) was ligated with fine suture and the RCL was removed, weighed (Right Cranial Lobe Wet Weight, RCLWW), and subsequently dried in an oven at 100° C for 48 hrs and reweighed (Right

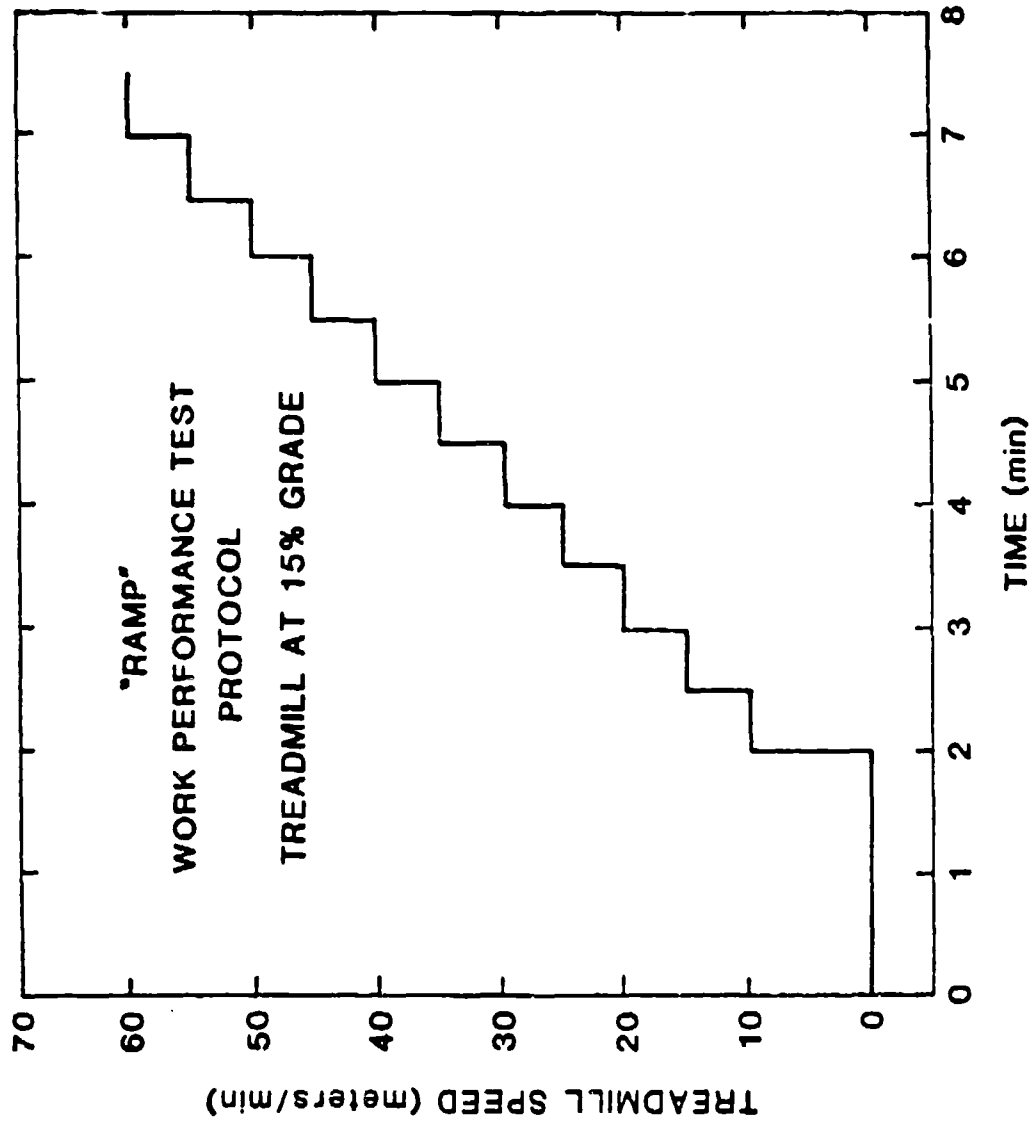

Figure 2. The "Ramp" work performance test begins with 2 minutes of rest followed by a 10 M/min starting work load. Five M/min increases in work load occur every 30 seconds until the rat attains its maximum oxygen consumption (VO_{2max}).

METABOLIC MEASUREMENT SYSTEM

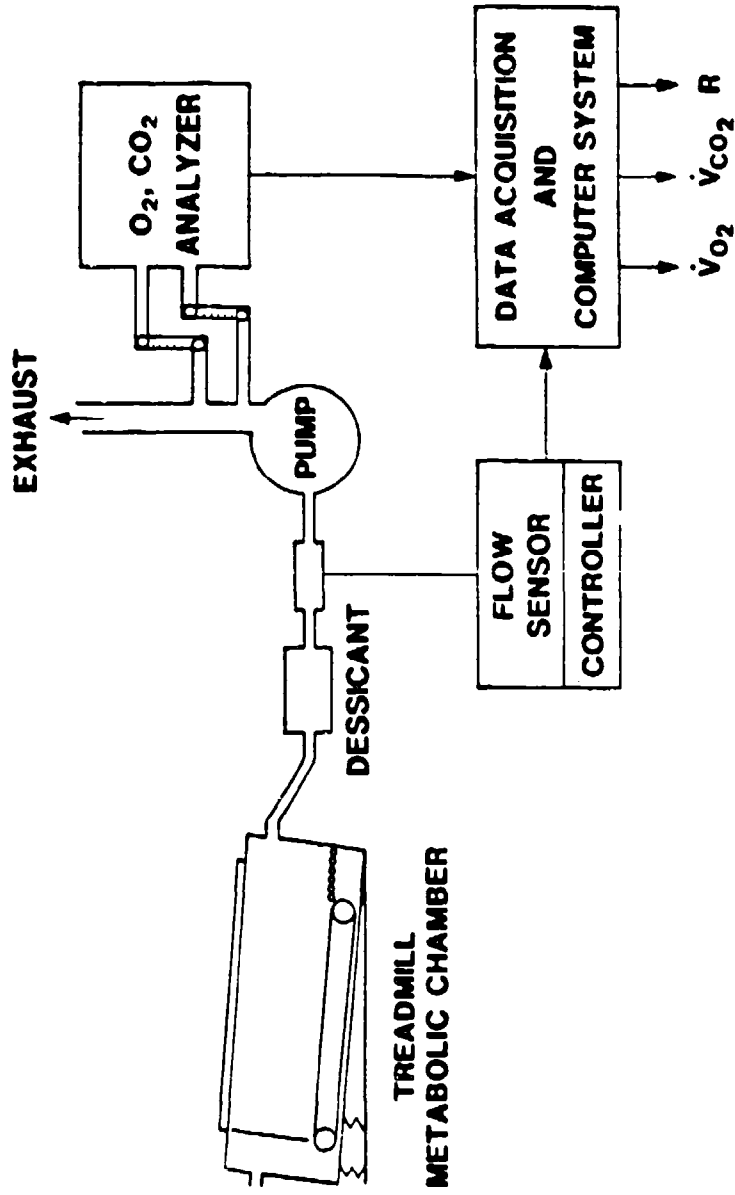

Figure 3. Metabolic measuring system to measure O₂ consumption and CO₂ production on exercising rats. Metered airflow is drawn across the running rat and sampled with real time O₂ and CO₂ analyzers. A data acquisition system calculates metabolic parameters every 3 seconds.

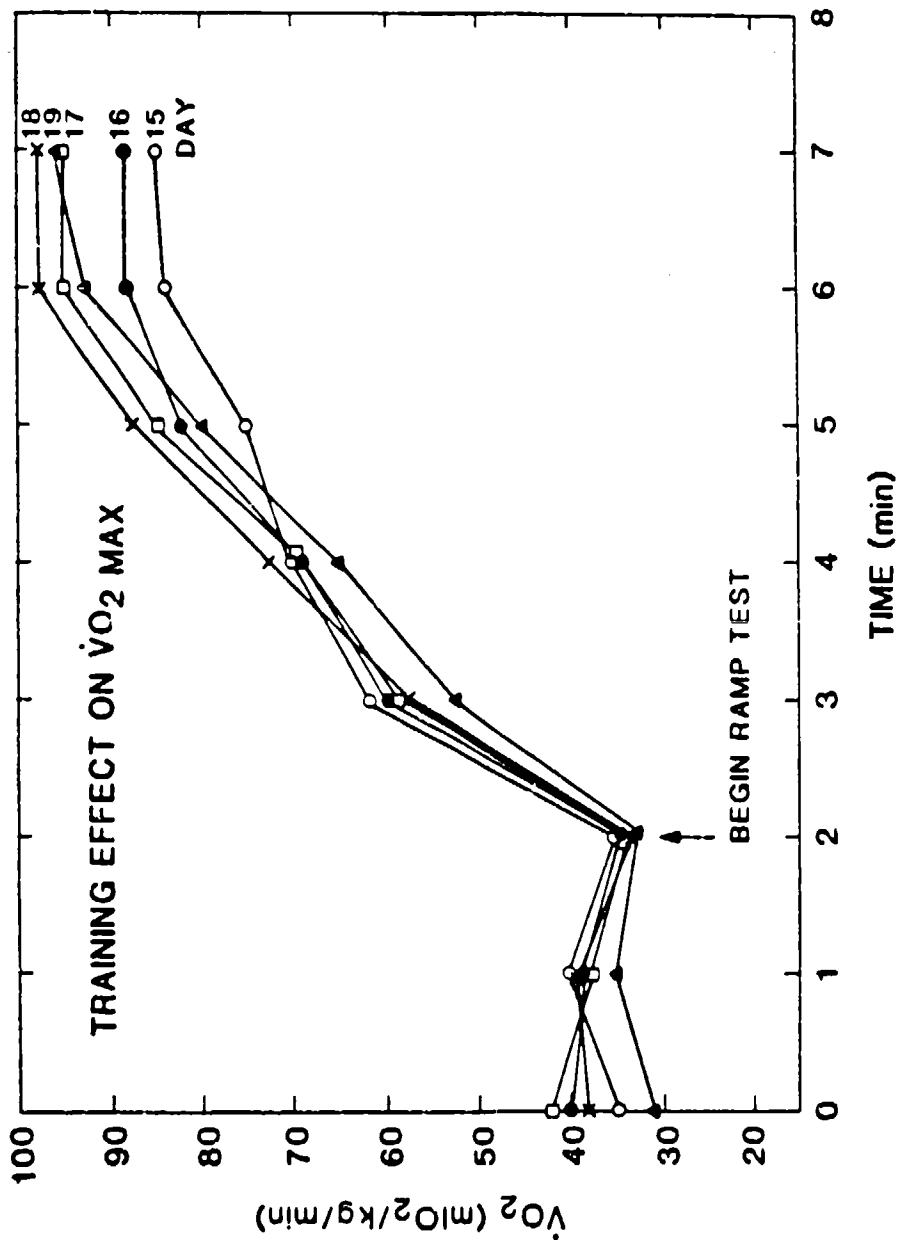

Figure 4. Oxygen consumption measurements on the same rat acquired during the "Ramp" exercise protocol on the last 5 days of the training protocol.

Cranial Lobe Dry Weight, RCLDW). Percent changes in the lung gravimetric parameters described herein were calculated as: $[(\text{post-exposure mean value} - \text{air control mean value}) / \text{air control mean value}] \times 100\%$. Inasmuch as post-exposure changes in the RCLDW and LWW endpoints generally paralleled one another, only the LWW and RCLDW data are presented in this report.

Unless otherwise indicated, the lungs (minus the RCL) were routinely submerged in 10% formalin in phosphate-buffered saline for 48 hr and prepared for histopathologic analysis. The fixation by submersion approach was used to preserve the appearance of edema fluid in the lung's air spaces. For histological analysis of the lung, each left lobe was sliced on the same plane as the main-stem bronchi from its apex to its base along a line between the most posterior to the most anterior aspects to expose the maximal planar surface area for sectioning (Stavert et al, 1986; Stavert and Lehnert, 1989; Stavert and Lehnert, 1990). The blocks of tissue were embedded in paraffin, and 4 μm sections were prepared and stained with hematoxylin and eosin by conventional methods.

Semi-Quantitative Histopathology. Histopathologic assessments focused on the appearance of edema fluid and fibrin, abnormal accumulations of polymorphonuclear leukocytes (PMN) and alveolar macrophages (AM), vascular congestion, and alveolar cuboidal cell hyperplasia, i.e. Type II cell hyperplasia. With the exception of vascular congestion, a grading scale was used to quantitatively describe the relative extent of each of the above pathologic features in terms of their: 1) *distribution*, i.e., relative portion of the lung showing a lesion; 2) *severity*, or the relative number of alveolar structures affected within the lesion area; and 3) *intensity*, i.e., the relative amount of material or relative alterations of cells in the alveoli. The distribution index for a given pathologic feature ranged from 0-4 with 0 = not observed, 1 = single or focal in appearance, 2 = few but multifocal, 3 = moderate portion of the lung involved, and 4 = all or essentially all alveolar structures were affected, i.e., diffuse. The relative severity index for a given pathologic feature ranged from 0 to 4 with 0 = no abnormality, 1 = the focal appearance of the abnormality in the lesion area alveolar structures, 2 = focal to multifocal appearance in the lesion area alveolar structures, 3 = several affected alveolar structures, and 4 = many to all lesion area alveolar structures demonstrate the abnormality. The relative intensity index ranged from 0 to 4 with 0 = no abnormality, 1 = trace but detectable alterations in the amount of abnormal material, 2 = mild amount of material or small changes in cell numbers, 3 = moderate amount of abnormal material or abnormal number of cells, and 4 = large amounts of intraalveolar material or large changes in cell numbers. For grading vascular congestion, only distribution and severity indices were used. In this case, the distribution index refers to the relative numbers of alveolar structures that showed capillary congestion in associated alveolar septal walls, and the severity index references the relative numbers of alveoli involved. The above histopathologic examinations were performed in a statistically blind fashion. Also, it should be noted that the above scoring system is similar to that used in previous studies in our laboratory in which the injurious effects of other toxic gases have been characterized (e.g., Lehnert and

Stavert, 1989; Stavert and Lehnert, 1990).

Electron Microscopy Studies. An ancillary transmission electron microscopic study was undertaken in order to investigate the acute ultrastructural features of PFIB-induced lung injury. In this study, rats were exposed to 100 or 200 mg/M³ PFIB as described above. After lethal injection of pentobarbital sodium, the lungs were removed, fixed via the trachea with 6 ml of 3% glutaraldehyde in 0.1 M phosphate buffer, and submerged in cold fixative overnight. A thick slice (~2 mm) through the central portion of the left lung perpendicular to the long axis was removed and cut into 1-2 mm pieces. These lung fragments were then post-fixed in 1% buffer osmium tetroxide (pH 7.2) and stained *en bloc* with 2% uranyl acetate at 60° C for 15 minutes. The lung samples were dehydrated in a graded series of ethanol and propylene oxide, and finally embedded in LX112 resin. Tissue blocks were thin sectioned (600-1000 Angstroms thick) and stained with lead citrate. Electron micrographs were made using a Philip 410 transmission electron microscope at 80 Kv.

Lung Free Cell Response and Lavage Fluid Biochemical Studies. An ancillary lung free cell response study was undertaken to obtain information about the appearance of inflammatory cells in the lung (or more precisely, cells that are lavageable from the conducting airways and the alveolar space compartment) following exposure to PFIB. For this investigation, rats were exposed to 100 mg/M³ PFIB (N=3) or clean filtered air (N=3) for 10 minutes. Twenty-four hours after the exposures, the lungs of sacrificed rats were lavaged 6 times with 8 ml of phosphate buffered saline (PBS) per wash cycle (Lehnert et al, 1989). The lavage fluids were centrifuged at 300 G for 10 min at 4° C to sediment cells, and the supernatants were removed. Pelleted cells were resuspended in PBS for cell counts. Aliquots were also used to make cytocentrifuged slide preparations for cell differential analysis after staining with Diff Quik® stain. As a second component of this same study, the lavage fluid supernatants were recentrifuged at 2300 G for 10 min to sediment acellular insoluble material, the supernatants were removed, and trifluoroacetic acid (TFA) was added to a concentration of 0.2%. Thereafter, the lavage fluids were further diluted 50/50 with 6M guanidine hydrochloride for the HPLC analysis. Analysis of the lavage fluids were performed by reverse phase High Performance Liquid Chromatography (HPLC) as previously described (Gurley 1989). Briefly, aliquots of lavage fluid were pumped through a μ Bondapak C₁₈ Radial-PAK HPLC column equilibrated with H₂O/0.2% TFA. Fractions were eluted with a series of acetonitrile (CH₃CN) gradients and isocratic steps that progressed from H₂O/0.2% TFA to 65% CH₃CN/0.2% TFA. Details about the HPLC method that has been developed in our laboratory for qualitatively and quantitatively characterizing constituents in bronchoalveolar lavage fluid have been reported elsewhere (Gurley et al, 1988; Gurley et al, 1989).

Statistical Analysis. Body weight and lung gravimetric data were analyzed for significant differences

between groups using a one-tailed t-test (Snedecor and Cochran, 1969a). The selection of a one-tailed t-test for these parameters was based on our previous investigations that have demonstrated that environmental insults essentially invariably result in decreases in body weights and increases in lung weights when the environmental insults cause acute lung injury. The histopathologic data were compared using the Mann-Whitney nonparametric test for unpaired data (Snedecor and Cochran, 1969b). The Mann-Whitney test was selected because the numeric expressions of the various histopathologic features of toxic gas-induced lung injury, as indexed by the previously described semi-quantitative scoring system, often do not appear to follow a Gaussian distribution within a given exposure group. In all statistical comparisons, probability values (p) \leq 0.05 were considered to denote significance.

Results

PFIB Exposure Concentrations: The actual measured exposure concentrations for the initially selected nominal exposure concentrations used in the study are summarized in Table 2. Hereafter, all references to exposure concentration of PFIB will refer to nominal concentrations.

EXPOSURE CONCENTRATION	
NOMINAL	ACTUAL (Mean ± S.E.M.)
50 mg/M ³	56 ± 2.1 mg/M ³
83 mg/M ³	82 ± 0.3 mg/M ³
90 mg/M ³	92 ± 1.7 mg/M ³
100 mg/M ³	101 ± 0.4 mg/M ³
110 mg/M ³	110 ± 0.5 mg/M ³
200 mg/M ³	206 ± 1.6 mg/M ³

Table 2. Mean PFIB mass concentrations measured during the concentration-response exposures.

Initial Range Finding PFIB Concentration-Response Studies

Body Weight Changes: Animals exposed to air only gained on average ~1% of their initial body weights 24 hr after the exposure, Table 3. In contrast, animals exposed to all concentrations of PFIB studied lost from 3% to 6% of their body weights during the 24 hr period after the exposure. Generally, the average loss in body weight following PFIB exposure increased with increasing PFIB exposure concentration.

TIME POST EXPOSURE	EXPOSURE TREATMENT					
	AIR	PFIB 50 mg/M ³	PFIB 83 mg/M ³	PFIB 90 mg/M ³	PFIB 100 mg/M ³	PFIB 110 mg/M ³
24 HR	3	-9*	-7*	-10*	-11*	-15*

Table 3. Mean body weight change (gm) upon sacrifice after exposure to air or various nominal concentrations of PFIB. (*) denotes significant difference from air control values (p≤0.05). Each exposure group consisted of 5 - 8 rats.

Lung Gravimetric Changes: Concentration-response relationships of LWW and RCLDW values measured 24 hr after exposure to various concentrations of PFIB are graphically summarized in Figures 5 and 6, respectively. LWW and RCLDW values obtained with animals exposed to 50 mg PFIB/M³ for a 10 min duration were not significantly different from those values obtained with rats exposed to clean air only. Significant increases in both LWW and RCLDW were detected 24 hr after exposure to PFIB exposure concentrations equal to and greater than 83 mg/M³. As indicated in Figures 5 and 6, the magnitude of PFIB-induced increases in LWW and RCLDW increased with exposure concentration, with changes in LWW and RCLDW following virtually identical patterns as a function of inhaled PFIB mass concentration. Approximately 30% (-LD30) of the animals exposed to 110 mg/M³ died within 24 hr after the exposure. Thus, the 110 mg/M³ PFIB LWW and RCLDW values illustrated in Figures 5 and 6 were obtained with surviving animals only.

Lung Histopathology. No histological abnormalities were observed in the lungs of rats exposed to air only (data not shown).

50 mg PFIB/M³

No major histological damage was detected in the lungs of animals exposed to 50 mg PFIB/M³, Table 4a and 4b. However, PFIB exposure to 50 mg/M³ did result in significant but relatively mild apparent increases in the distribution, severity, and intensity of alveolar macrophages (AM) in the lung.

83 and 90 mg PFIB/M³

After exposure to the higher PFIB concentrations of 83 mg/M³ and 90 mg/M³, significant increases in the distribution and amount of fibrin observed in alveoli was occasionally apparent. Also, evidence of an influx of PMN was observed in the lungs of animals exposed to these levels of PFIB, even though this finding could not be confirmed statistically. No evidence of perivascular congestion was observed following these exposure concentrations. As well, Type II cell hyperplasia was not a prominent response following the 83 and 90 mg/M³ exposures to PFIB. Similar to 50 mg/M³ exposure condition, exposure to 83 and 90 mg/M³ PFIB caused significant increases in the distribution, severity, and intensity of AM.

100 and 110 mg PFIB/M³

The lungs of animals exposed to 100 mg/M³ and 110 mg/M³ showed moderate to large amounts of edema fluid, and fibrin was widely present in the alveoli. Cellular responses observed following the inhalation of these higher concentrations of PFIB mainly included significant influxes of PMN and apparent significant increases in AM. Some evidence of perivascular congestion was observed following the 110 mg/M³ exposure, but the low level of expression of this pathologic feature precluded firm statistical demonstration of its presence.

LUNG WET WEIGHT INCREASE (24 HR POST EXPOSURE)
RELATIVE TO INHALED PFIB CONCENTRATION

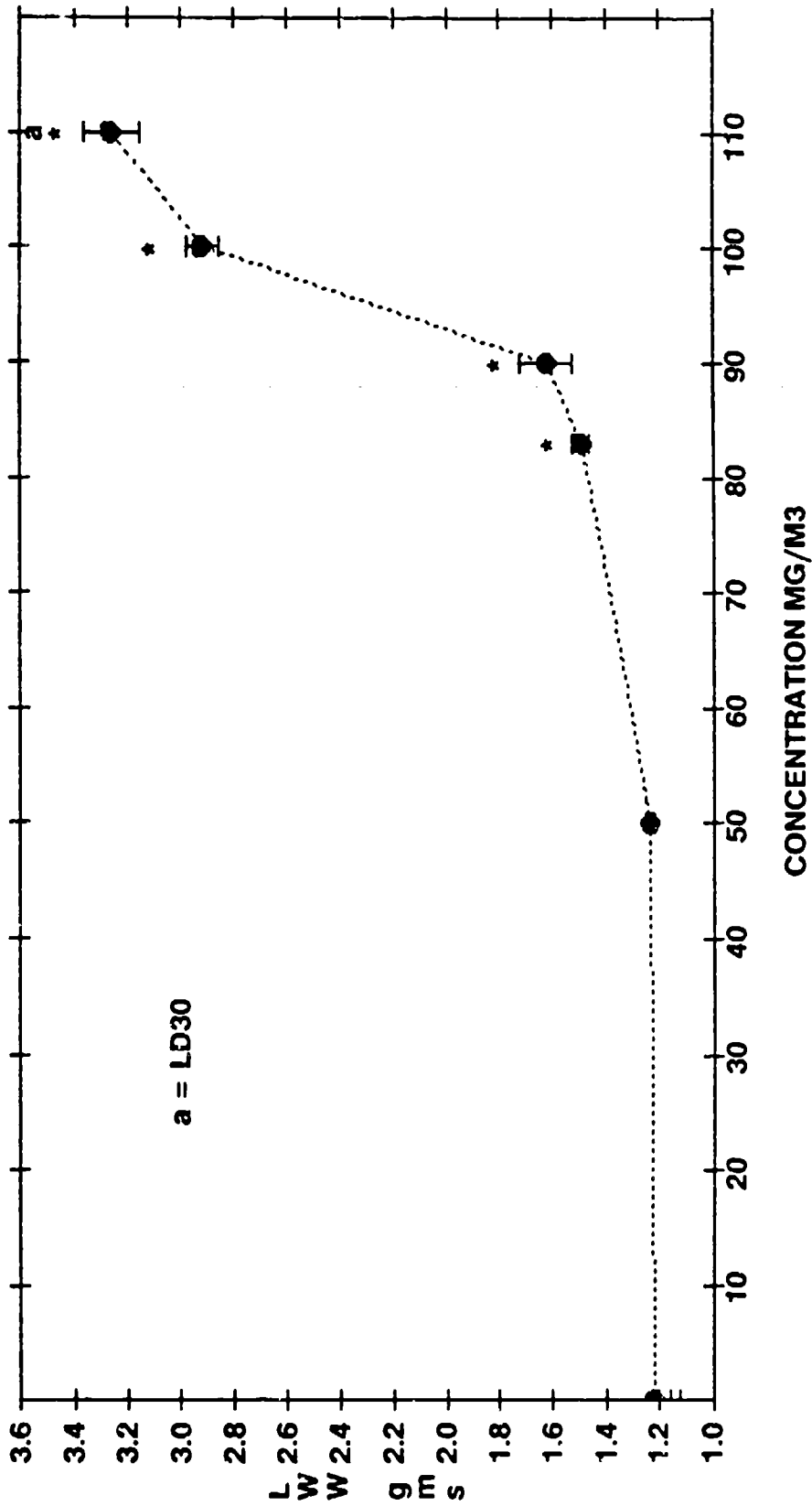

Figure 5. Lung wet weight (LWW) values of animals exposed to air or various nominal concentrations of PFIB for a 10 min duration. Each point represents the mean and SEM of 6 to 8 animals. (*) indicate significant increases compared to values measured on animals exposed to air only, ($p \leq 0.05$).

**RIGHT CRANIAL LOBE DRY WEIGHT (24 HR POST EXPOSURE)
RELATIVE TO INHALED PFIB CONCENTRATION**

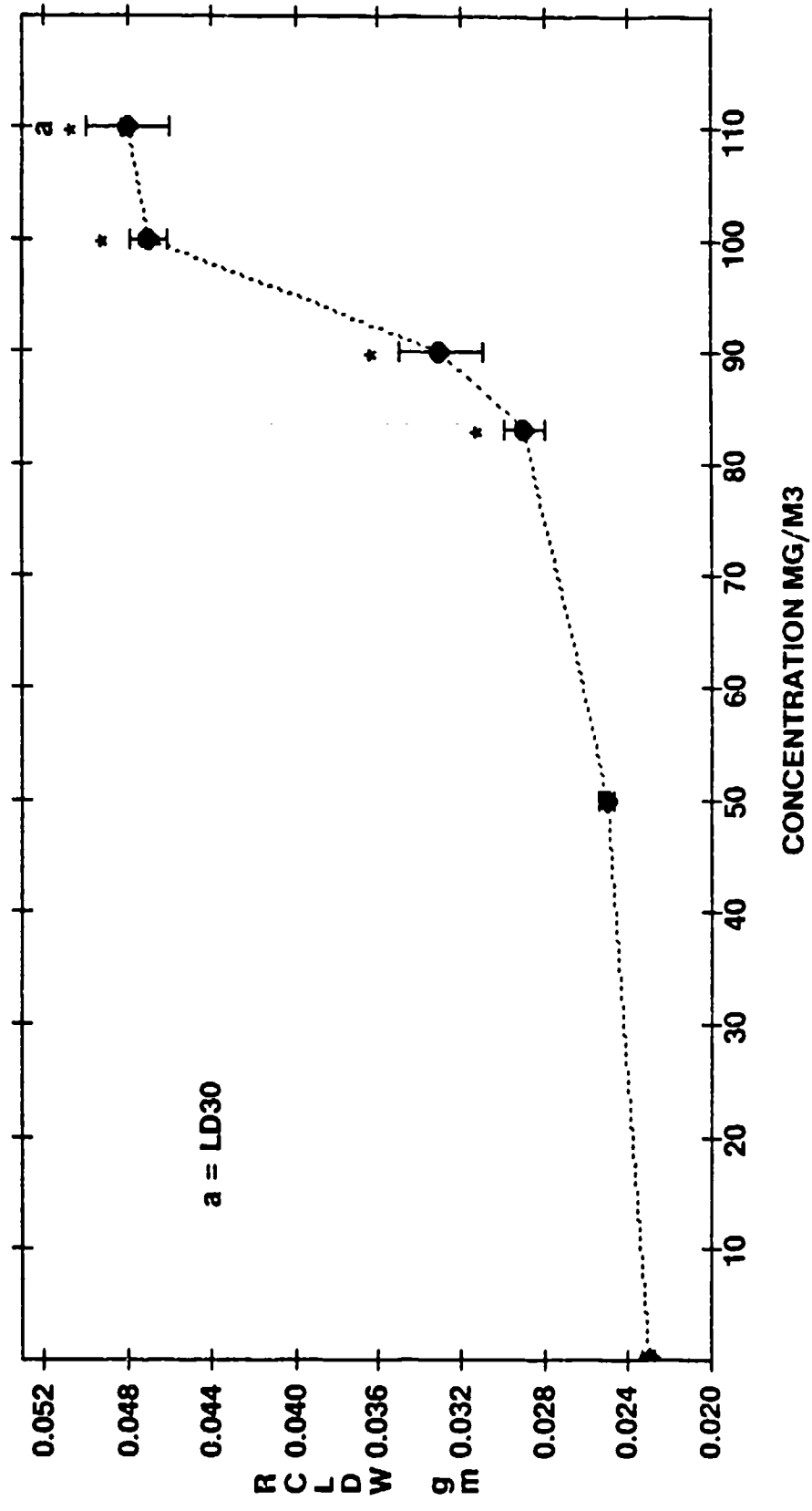

Figure 6. Right cranial lobe dry weight (RCLDW) values of animals exposed to air or various nominal concentrations of PFIB for a 10 minute duration. Each point represents the mean and SEM of 6 to 8 animals. (*) indicate significant increases compared to values measured on animals exposed to air only, (p ≤ 0.05).

Nominal Exposure Concentration mg/M ³	<i>Distribution</i>	<i>Severity</i>	<i>Intensity</i>
	Edema Fluid		
50	0	0	0
83	0	0	0
90	0	0	0
100	2.5 ± 0.2*	3.0 ± 0.0*	3.3 ± 0.2*
110	2.4 ± 0.2*	2.2 ± 0.1*	2.8 ± 0.1*
Fibrin			
50	0	0	0
83	2.0 ± 0.0*	1.0 ± 0.0*	1.0 ± 0.0*
90	0	0	0
100	2.7 ± 0.2*	2.6 ± 0.3*	2.2 ± 0.2*
110	2.9 ± 0.1*	2.8 ± 0.2*	2.2 ± 0.2*
Polymorphonuclear Leukocytes			
50	0	0	0
83	0.2 ± 0.2	0.2 ± 0.2	0.4 ± 0.4
90	0.4 ± 0.3	0.4 ± 0.3	0.4 ± 0.3
100	2.3 ± 0.2*	1.7 ± 0.2*	1.9 ± 0.2*
110	2.4 ± 0.4*	1.6 ± 0.2*	1.3 ± .02*
Macrophages			
50	2.0 ± 0.0*	1.0 ± 0.0*	1.2 ± 0.2*
83	1.8 ± 0.2*	1.0 ± 0.0*	1.6 ± 0.2*
90	1.3 ± 0.4*	0.8 ± 0.3*	1.0 ± 0.3*
100	3.0 ± 0.1*	2.6 ± 0.2*	2.4 ± 0.2*
110	3.0 ± 0.0*	2.3 ± 0.2*	2.1 ± 0.1*

Table 4a. Histopathologic evaluation of the dose response of the lung after exposure to various nominal concentrations of PFIB. (*) denotes significant difference from air exposed values, $p \leq 0.05$.

Nominal Exposure Concentration mg/M ³	Distribution	Severity	Intensity
Type II Cell Hyperplasia			
50	0	0	0
83	0.4 ± 0.4	0.4 ± 0.4	0.4 ± 0.4
90	0.1 ± 0.1	0.3 ± 0.3	0.1 ± 0.1
100	0	0	0
110	0	0	0
Perivascular Congestion			
50	0	0	
83	0	0	
90	0	0	
100	0	0	
110	0.9 ± 0.4	0.9 ± 0.4	

Table 4b. Histopathologic evaluation of the dose response of the lung after exposure to various nominal concentrations of PFIB. (*) denotes significant difference from air exposed values, p ≤ 0.05.

PFIB Concentration-Kinetic Response Studies

Body Weight Changes: Initial weight losses of approximately 3% of starting body weights occurred within the first 8 hr after exposure to all experimental atmospheres, including air, Table 5. Weight losses were recovered by 24 hr in animals exposed to air only whereas body weights continued to be diminished in those animals exposed to all concentrations of PFIB. The depression of body weights continued to occur for 48 and 72 hr post-exposure for PFIB concentrations of 90 mg/M³ to 110 mg/M³.

TIME POST EXPOSURE	EXPOSURE TREATMENT						
	AIR	PFIB 50 mg/M ³	PFIB 83 mg/M ³	PFIB 90 mg/M ³	PFIB 100 mg/M ³	PFIB 110 mg/M ³	PFIB 200 mg/M ³
1 HR	-7			-3	-4	-4	-9
8 HR	-10			-7	-10	-8	
24 HR	3	-9*	-7*	-10*	-11*	-15*	
48 HR	0			-7*	-8*		
72 HR	3			-3*	-4*		

Table 5. Mean body weight change (gm) upon sacrifice after exposure to air or various nominal concentrations of PFIB. (*) denotes significant difference from air control values ($p \leq 0.05$). Each exposure group consisted of 5 - 8 rats.

Lung Gravimetric Changes: LWW and RCLDW values measured at various times after exposure to the several different concentrations of PFIB are summarized in Figure 7 and Figure 8, respectively. The changes that occurred following exposure to the various concentrations of PFIB examined are separately described below. It should be noted that for each PFIB concentration examined, a corresponding control group of animals was exposed to clean air only. It should also be noted that relative to unexposed, cage control rats, no significant differences occur in the LWW or RCLDW parameters when animals are exposed to clean filtered air for 10 min and examined over a 72 hr period thereafter.

90 mg PFIB/M³

No increases in LWW or RCLDW were detected 1 hr and 8 hr after exposure to 90 mg/M³ PFIB. However, compared to air exposed control values, significant increases in LWW of approximately 34%, 52%, and 34% were observed at the 24 hr, 48 hr and 72 hr sacrifice time points, respectively, after exposure to the 90 mg /M³ mass concentration of PFIB. RCLDW values were also significantly elevated ~27%, ~70%, and ~31% above air control values at the 24 hr, 48 hr and 72 hr post-exposure time points, respectively.

LUNG WET WEIGHT INCREASE AFTER ACUTE EXPOSURE TO VARIOUS CONCENTRATIONS OF PFIB

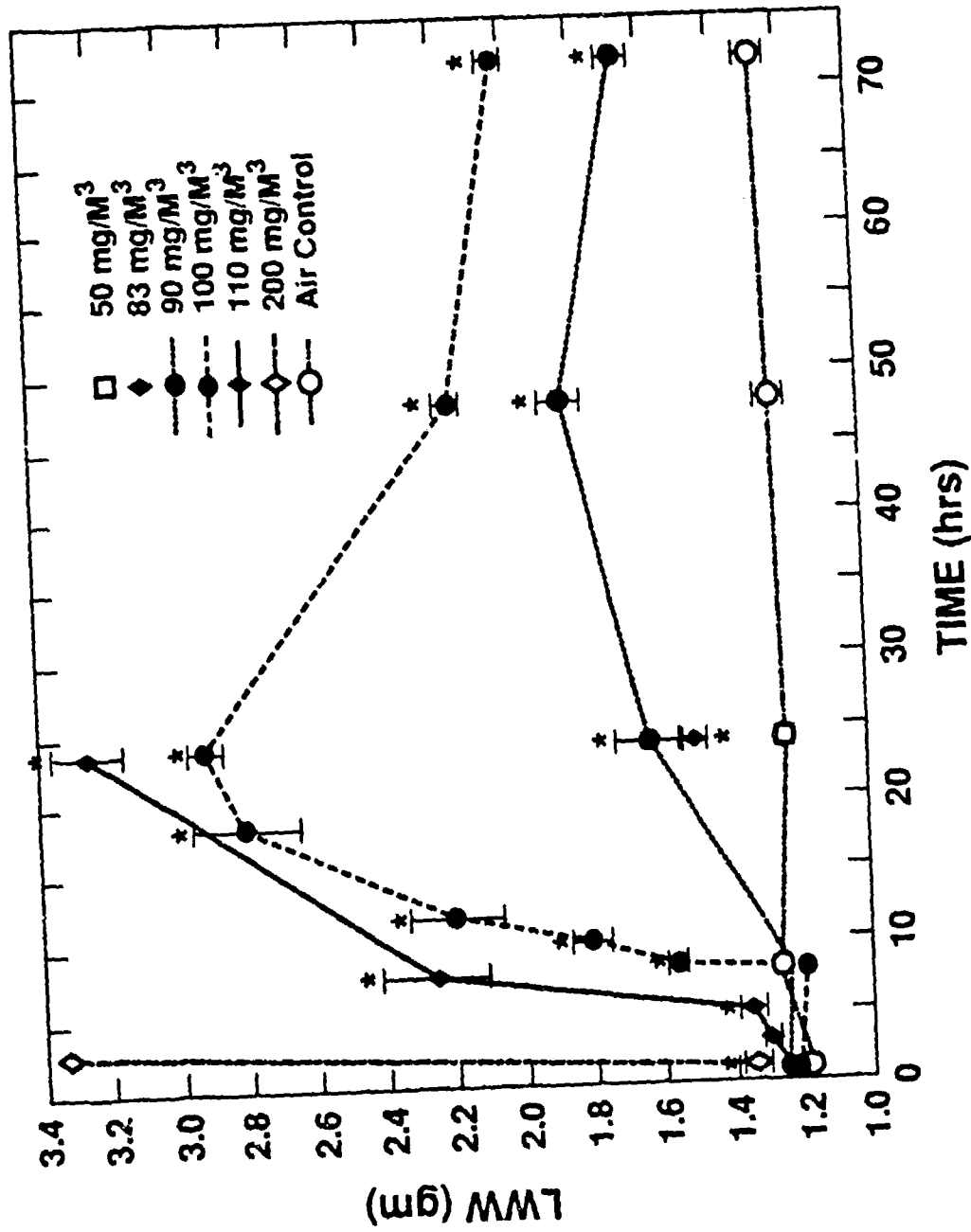

Figure 7. Kinetics of development of pulmonary edema as represented by increases in lung wet weight (LWW) values measured at various times after exposure to several concentrations of PFIB. Each point represents the mean and SEM of N = 5 to 8 rats. (*) indicates significant differences compared to values measured on air exposed animals, (p ≤ 0.05).

KINETICS OF RIGHT CRANIAL LOBE DRY WEIGHT GAINS AFTER ACUTE EXPOSURE TO VARIOUS CONCENTRATIONS OF PFIB

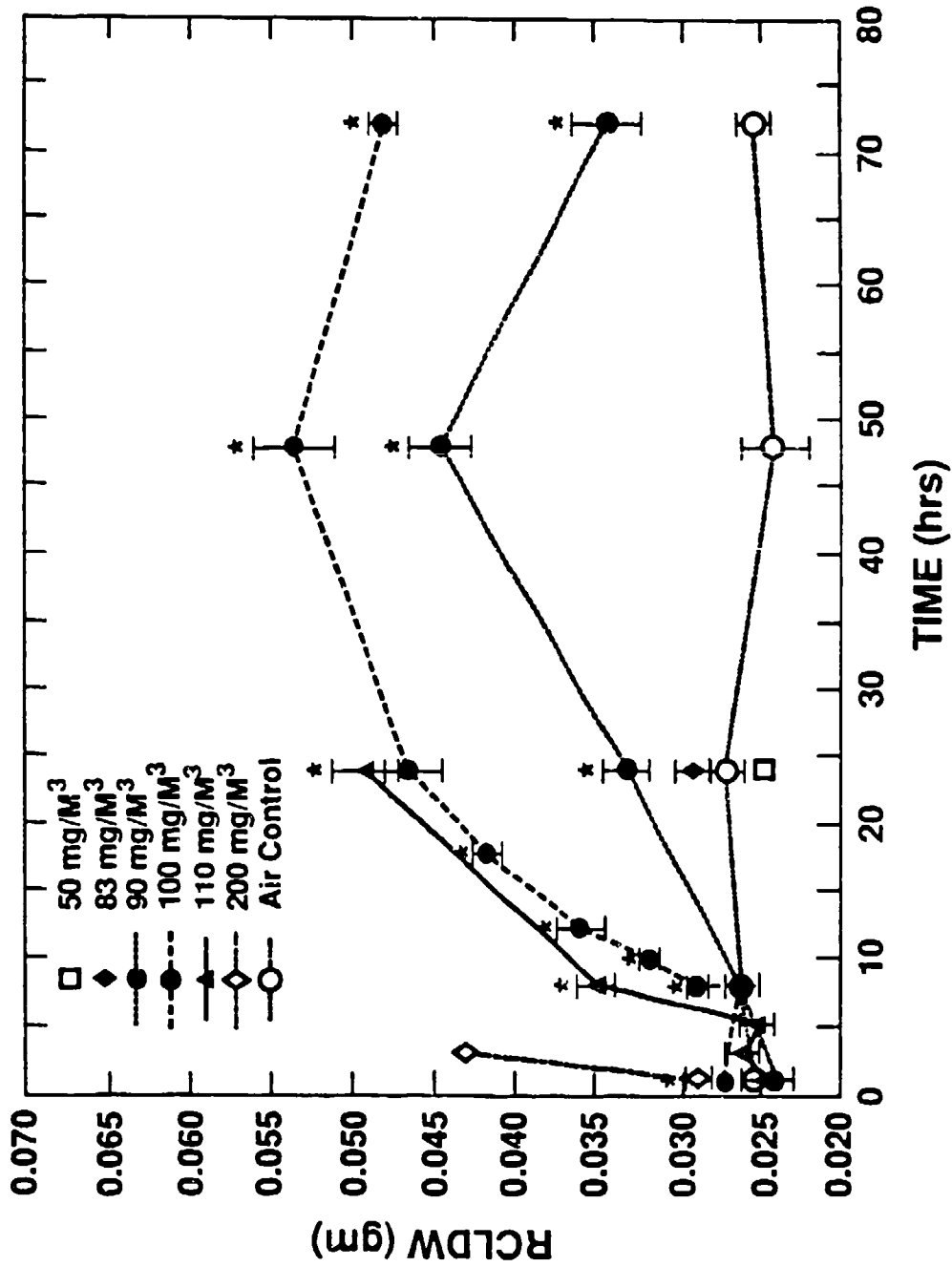

Figure 8. Kinetics of development of pulmonary edema as represented by increases in right cranial lobe dry weight (RCLDW) values measured at various times after exposure to several concentrations of PFIB. Each point represents the mean and SEM of N = 5 to 8 rats. (*) indicates significant differences compared to values measured on air exposed animals, (p < 0.05)

100 mg PFIB/M³

Special, more detailed attention was given to the kinetics of the injurious response to the 100 mg/M³ mass concentration of PFIB in as much as our collective findings regarding PFIB concentration - responses suggested that this concentration would usefully serve for the exercise and work performance components of the study. As with values obtained after exposure to 90 mg/M³ PFIB, LWW and RCLDW values 1 and 8 hr after exposure to 100 mg/M³ PFIB were not significantly elevated relative to values obtained with control air exposed rats. However, as of 9 hr after exposure to 100 mg/M³ PFIB, LWW and RCLDW values were elevated ~31% and 11%, respectively. The rapid increase in LWW that occurred between the 8 and 9 hr post-exposure sacrifice times continued for several hours thereafter, i.e., 10 hr: ~39%, 12 hr: ~77%, and 18 hr: ~133%. Similarly, RCLDW values of ~19%, ~33%, and ~50% above control values were measured at these later respective time points. As of 24 hr after exposure to 100 mg/M³ PFIB, the LWW and RCLDW values had increased ~138% and ~67%, respectively. As of 48 hr after exposure, LWW began to decrease whereas RCLDW values continued to increase. Although continuing to be substantially elevated, both the LWW and RCLDW values appeared to decrease in magnitude as of the latest 72 hr sacrifice time point.

110 mg PFIB/M³

LWW values measured 1 hr after exposure to 110 mg/M³ were slightly yet significantly elevated (~8%) compared to values measured with animals exposed to air only. No significant changes in RCLDW, however, were detected at this early post-exposure time point. Marked increases in LWW (~79%) and RCLDW (~37%) values were obtained, however, as of 8 hr after exposure to 110 mg/M³ PFIB. This rapid increase in LWW and RCLDW continued 24 hr post-PFIB exposure with LWW increases of ~166% and RCLDW increases of ~71% above air exposed control values. Approximately 30% of the animals exposed to 110 mg/M³ PFIB died before the 24 hour sacrifice time point.

200 mg PFIB/M³

One hr after exposure to 200 mg/M³ PFIB, significant increases in LWW and RCLDW were measured. These values corresponded to an ~12% increase of LWW and an ~12% increase in RCLDW values compared to air exposed values obtained at the 1 hr time point. Only 1 out of 5 rats exposed to 200 mg /M³ PFIB survived to the 3 hr after exposure. As of this post-exposure time, the lone survivor had a LWW value ~177% above control values and an RCLDW value of ~65% above control values.

Lung Histopathology:

90 mg PFIB/M³

Lung histopathologic scores for animals that were exposed to 90 mg/M³ PFIB and subsequently sacrificed at various times thereafter are summarized in Table 6. It should be noted that the lungs of animals exposed to 90 mg/M³ PFIB were fixed by infusing fixative at a constant pressure via the trachea. Thus, results obtained with this group of exposed rats may not be directly compared quantitatively with

90 mg/M ³ Post Exposure Time	<i>Distribution</i>	<i>Severity</i>	<i>Intensity</i>
	Fibrin		
1 Hr	0.1 ± 0.1	0.1 ± 0.1	0.1 ± 0.1
8 Hr	0.5 ± 0.3	0.3 ± 0.2	0.4 ± 0.3
24 Hr	0	0	0
48 Hr	0.1 ± 0.1	0.3 ± 0.3	0.3 ± 0.3
Polymorphonuclear leukocytes			
1 Hr	0	0	0
8 Hr	0	0	0
24 Hr	0.4 ± 0.3	0.4 ± 0.3	0.4 ± 0.3
48 Hr	1.1 ± 0.4	0.9 ± 0.3	0.6 ± 0.2
Macrophages			
1 Hr	0.3 ± 0.2	0.8 ± 0.5	0.7 ± 0.5
8 Hr	0.3 ± 0.3	0.1 ± 0.1	0.3 ± 0.3
24 Hr	1.3 ± 0.4*	0.8 ± 0.3*	1.0 ± 0.3*
48 Hr	2.1 ± 0.1*	2.0 ± 0.2*	1.6 ± 0.2*
Type II Cell Hyperplasia			
1 Hr	0	0	0
8 Hr	0	0	0
24 Hr	1.3 ± 0.4*	0.8 ± 0.3*	1.0 ± 0.3*
48 Hr	1.7 ± 0.4*	1.7 ± 0.4*	1.4 ± 0.3*

Table 6. Histopathologic evaluation of lung at various times after nominal 90 mg/M³ PFIB exposures. (*) denotes significant difference from air exposed values, p ≤ 0.05.

the other groups described in this section in which lung fixation was accomplished by the submersion technique that was previously described in the Materials and Methods Section. No edema fluid was observed after exposure to 90 mg/M³ PFIB, perhaps because of the fixation method employed. As well, no significant quantities of fibrin were observed at any time point after exposure to 90 mg/M³, Table 6. Significant accumulations of AM, however, were observed 24 hr and 48 hr after exposure to this concentration of PFIB compared to air exposed values. Also, perhaps because of the fixation technique

employed for this group of animals, Type II cell hyperplasia was observed in significant abundance at 24 hr and 48 hr post 90 mg/M³ PFIB exposure. The Type II cell hyperplastic response is difficult to detect in lung tissue that has been fixed by submersion in that with this latter fixation method, alveoli are usually not well expanded.

100 mg PFIB/M³

Histopathologic scores for the kinetic response of lung injury after exposure to 100 mg/M³ PFIB are summarized in Tables 7-11. Corresponding to the lung gravimetric data, significant accumulations of edema fluid, Table 7, were not apparent until 9 hr after the exposure to 100 mg/M³ PFIB. Peak edema fluid amounts were observed 24 hr after exposure. No fibrin was detected until 10 hr after exposure to 100 mg/M³, Table 8. Accumulations of fibrin were observed 10 to 18 hr after exposure, but such accumulations were not statistically significant. Significant amounts of fibrin did, however, occur 18 to 24 hr after exposure to this level of PFIB, while no fibrin was detected in the alveolar spaces as of 48 to 72 hr after PFIB exposure. An influx of PMN was detected as early as 8 hr after exposure to 100 mg/M³, Table 9, but statistically significant accumulations of PMN did not occur until 12 to 24 hr after exposure. Thereafter, the relative abundance of PMN appeared to subside. Significant apparent increases in AM were observed as of 10 hr post PFIB exposure with peak observable numbers occurring between the 24 and 48 hr post-exposure time points, Table 10. The appearance of perivascular congestion was most prevalent 18 hr after exposure to 100 mg/M³ PFIB, Table 11.

110 mg PFIB/M³

The lungs of animals exposed to 110 mg/M³ PFIB showed no evidence of histopathologic abnormalities at the 1 hr, 3 hr, or 5 hr post-exposure time points, Table 12. As of 8 hr post 110 mg/M³ PFIB exposure, however, a significant increase in edema fluid was observed. Fibrin was also observed at the 8 hr sacrifice time point, but this elevation was not statistically significant. Significant apparent accumulations of AM were also evident as of 8 hr after the 110 mg/M³ PFIB exposure. As of 24 hr after exposure to this concentration of PFIB, significant amounts of edema fluid and fibrin were evident, and substantial numbers of PMN and AM were also observed.

A preliminary report on the above PFIB concentration-response kinetics has been presented elsewhere (Stavert et al, 1990).

<u>100 mg/M³ PFIB</u>	<i>Distribution</i>	<i>Severity</i>	<i>Intensity</i>
Post Exposure Time	Edema Fluid		
1 Hr	0	0	0
8 Hr	0.5 ± 0.3	0.6 ± 0.4	0.5 ± 0.3
9 Hr	1.5 ± 0.3*	2.2 ± 0.2*	1.3 ± 0.2*
10 Hr	1.9 ± 0.3*	2.0 ± 0.3*	2.1 ± 0.4*
11 Hr	2.2 ± 0.2*	2.0 ± 0.0*	2.2 ± 0.2*
12 Hr	2.5 ± 0.2*	1.8 ± 0.2*	2.1 ± 0.2*
18 Hr	2.2 ± 0.2*	2.0 ± 0.0*	2.8 ± 0.2*
24 Hr	2.5 ± 0.2*	3.0 ± 0.0*	3.3 ± 0.2*
48 Hr	2.2 ± 0.2*	2.8 ± 0.2*	2.4 ± 0.3*
72 Hr	2.0 ± 0.0*	2.5 ± 0.2*	2.3 ± 0.2*

Table 7. Histopathologic scores of the accumulation of edema fluid from the lungs of animals at designated times after nominal 100 mg/M³ PFIB exposures (see text for histopathologic scoring details). (*) indicates significant difference between PFIB exposed and clean air exposed controls. (p ≤ 0.05).

<u>100 mg/M³ PFIB</u> Post Exposure Time	Distribution	Severity	Intensity
	Fibrin		
1 Hr	0	0	0
8 Hr	0	0	0
9 Hr	0	0	0
10 Hr	0.9 ± 0.4	0.9 ± 0.4	0.6 ± 0.3
11 Hr	0.8 ± 0.5	0.8 ± 0.5	0.8 ± 0.5
12 Hr	1.3 ± 0.6	0.8 ± 0.4	0.8 ± 0.0
18 Hr	1.8 ± 0.5*	1.6 ± 0.4*	1.6 ± 0.4*
24 Hr	2.7 ± 0.2*	2.6 ± 0.3*	2.2 ± 0.2*
48 Hr	0	0	0
72 Hr	0	0	0

Table 8. Histopathologic scores of the accumulation of fibrin from the lungs of animals at designated times after nominal 100 mg/M³ PFIB exposures (see text for histopathologic scoring details). (*) indicates significant difference between PFIB exposed and clean air exposed controls, (p ≤ 0.05).

<u>100 mg/M³ PFIB</u> Post Exposure Time	Distribution	Severity	Intensity
Polymorphonuclear Leukocytes			
1 Hr	0	0	0
8 Hr	0.3 ± 0.3	0.1 ± 0.1	0.1 ± 0.1
9 Hr	0.5 ± 0.3	0.3 ± 0.2	0.3 ± 0.2
10 Hr	0.8 ± 0.4	0.5 ± 0.3	0.5 ± 0.3
11 Hr	0.4 ± 0.4	0.4 ± 0.4	0.2 ± 0.2
12 Hr	1.8 ± 0.4*	1.2 ± 0.3*	1.2 ± 0.3*
18 Hr	1.6 ± 0.5*	1.8 ± 0.5*	1.4 ± 0.5*
24 Hr	2.3 ± 0.2*	1.7 ± 0.2*	1.9 ± 0.2*
48 Hr	1.4 ± 0.6	1.2 ± 0.5	1.2 ± 0.5
72 Hr	0.7 ± 0.3	1.5 ± 0.7	1.0 ± 0.5

Table 9. Histopathologic scores of the occurrence of polymorphonuclear leukocytes in the lungs of animals at designated times after nominal 100 mg/M³ PFIB exposures (see text for histopathologic scoring details). (*) indicates significant difference between PFIB exposed and clean air exposed controls, ($p \leq 0.05$).

100 mg/M ³ PFIB Post Exposure Time	Distribution	Severity	Intensity
	Macrophages		
1 Hr	C	0	C
8 Hr	0.5 ± 0.3	0.5 ± 0.3	0.4 ± 0.3
9 Hr	0.8 ± 0.5	0.7 ± 0.4	0.7 ± 0.4
10 Hr	2.0 ± 0.4*	1.9 ± 0.3*	1.8 ± 0.3*
11 Hr	2.4 ± 0.3*	2.2 ± 0.2*	2.0 ± 0.0*
12 Hr	2.5 ± 0.2*	2.0 ± 0.0*	2.0 ± 0.0*
18 Hr	2.8 ± 0.2*	2.0 ± 0.0*	2.0 ± 0.0*
24 Hr	3.0 ± 0.2*	2.6 ± 0.2*	2.4 ± 0.2*
48 Hr	4.0 ± 0.0*	3.6 ± 0.3*	3.0 ± 0.0*
72 Hr	2.0 ± 0.0*	2.2 ± 0.2*	2.0 ± 0.0*

Table 10. Histopathologic scores of the occurrence of macrophages in the lungs of animals at designated times after nominal 100 mg/M³ PFIB exposures (see text for histopathologic scoring details). (*) indicates significant difference between PFIB exposed and clean air exposed controls. (p ≤ 0.05).

<u>100 mg/M³ PFIB</u>	<i>Distribution</i>	<i>Severity</i>
Post Exposure Time	Perivascular Congestion	
1 Hr	0	0
8 Hr	0	0
9 Hr	0.5 ± 0.5	0.3 ± 0.3
10 Hr	0	0
11 Hr	0	0
12 Hr	1.0 ± 0.5	1.5 ± 0.7
18 Hr	1.6 ± 0.4*	1.6 ± 0.4*
24 Hr	0	0
48 Hr	0	0
72 Hr	0	0

Table 11. Histopathologic scores of perivascular congestion in the lungs of animals at designated times after nominal 100 mg/M³ PFIB exposures (see text for histopathologic scoring details). (*) indicates significant difference between PFIB exposed and clean air exposed controls. (p ≤ 0.05).

110 mg/m³	<i>Distribution</i>	<i>Severity</i>	<i>Intensity</i>
Post Exposure Time	Edema Fluid		
1 Hr	0	0	0
3 Hr	0	0	0
5 Hr	0	0	0
8 Hr	2.8 ± 0.3*	2.3 ± 0.3*	2.5 ± 0.3*
24 Hr	2.4 ± 0.2*	2.2 ± 0.1*	2.8 ± 0.1*
	Fibrin		
1 Hr	0	0	0
3 Hr	0	0	0
5 Hr	0	0	0
8 Hr	1.0 ± 0.6	1.0 ± 0.6	1.0 ± 0.6
24 Hr	2.9 ± 0.1*	2.8 ± 0.2*	2.2 ± 0.2*
	Polymorphonuclear Leukocytes		
1 Hr	0	0	0
3 Hr	0	0	0
5 Hr	0	0	0
8 Hr	0.5 ± 0.5	0.5 ± 0.5	0.5 ± 0.5
24 Hr	2.4 ± 0.3*	1.6 ± 0.2*	1.3 ± 0.2*
	Macrophages		
1 Hr	0	0	0
3 Hr	0	0	0
5 Hr	0	0	0
8 Hr	2.0 ± 0.7*	1.5 ± 0.5*	1.5 ± 0.5*
24 Hr	3.0 ± 0.0*	2.3 ± 0.2*	2.1 ± 0.1*

Table 12. Histopathologic evaluation of lung at various times after nominal 110 mg/M³ PFIB exposures. (*) denotes significant difference from air exposed values, p ≤ 0.05.

PFIB Exercise Studies

Based on the results of the previous studies and after consultation with the Institute of Chemical Defense, a decision was made to use 100 mg/M³ PFIB in the exercise potentiation and work performance capacity components of the project.

Lung Gravimetric Changes/Single Exercise Bout: The data summarized in Figures 9 and 10 represent the post-exposure LWW and RCLDW measurements from animals that were exposed to 100 mg/M³ PFIB for 10 min and rested or subjected to a single exercise bout at various times during the latency period following exposure. No significant difference in LWW or RCLDW occurred if animals were exercised immediately after exposure and sacrificed 1 hr after exposure when compared to LWW and RCLDW values obtained on animals exposed to PFIB and rested after exposure. As well, exercise immediately after exposure to 100 mg/M³ PFIB had no longer term effect on PFIB-induced lung injury; the LWW and RCLDW values obtained with animals that were exposed to this concentration of PFIB, exercised immediately post-exposure, and sacrificed 24 hr after exposure were not significantly different than values obtained from animals exposed in like fashion but rested until they were sacrificed 24 hr after the exposure. The LWW and RCLDW values obtained from animals that were exposed to 100 mg/M³ PFIB, exercised 6 hr later, and subsequently sacrificed 8 hr after exposure were also not significantly different from those values obtained from rats that were exposed to the PFIB but allowed to rest until the corresponding sacrifice time.

The data in Figures 11 and 12 summarize the post-exposure LWW and RCLDW values from animals exposed to 100 mg/M³ PFIB for 10 min and exercised or rested at other various times after exposure to PFIB. Significant increases in LWW (~41%) and RCLDW (~13%) were obtained when animals were exercised 9 hr after PFIB exposure and then sacrificed 10 hr post-exposure when compared to PFIB exposed and rested values. LWW values from this exercised group remained significantly elevated for 24 hrs (~23%) compared to the post-exposure rested group that was sacrificed 24 hr after exposure. However, the RCLDW values from the animals that were exercised 9 hr post-exposure did not continue to remain elevated as of the 24 hr sacrifice time. When animals were exercised 10 hr post 100 mg/M³ PFIB exposure, significant increases of LWW (~41%) were also measured 11 hr post-exposure when compared to PFIB exposed and rested control counterparts. RCLDW was not measured for this group. Exercise performed 17 hr after PFIB exposure also potentiated the LWW response when animals were sacrificed at the 18 hr post-exposure time point. LWW values were elevated ~10% over values measured with exposed and rested animals sacrificed 18 hr after exposure. The RCLDW values from animals exercised 17 hr post PFIB exposure followed by an 18 hr sacrifice were not significantly different from the RCLDW values obtained with rats that were rested after PFIB exposure and sacrificed 18 hr after the exposure. Exercise performed 23 hr post 100 mg/M³ PFIB had no potentiating effect on LWW or RCLDW values measured at the 24 hr post-exposure time point. As well, exercise performed 47 hr

**EFFECTS OF POST EXPOSURE EXERCISE
PERFORMED DURING THE LATENCY PERIOD
AFTER EXPOSURE TO 100 MG/M PFIB X 10 MIN**

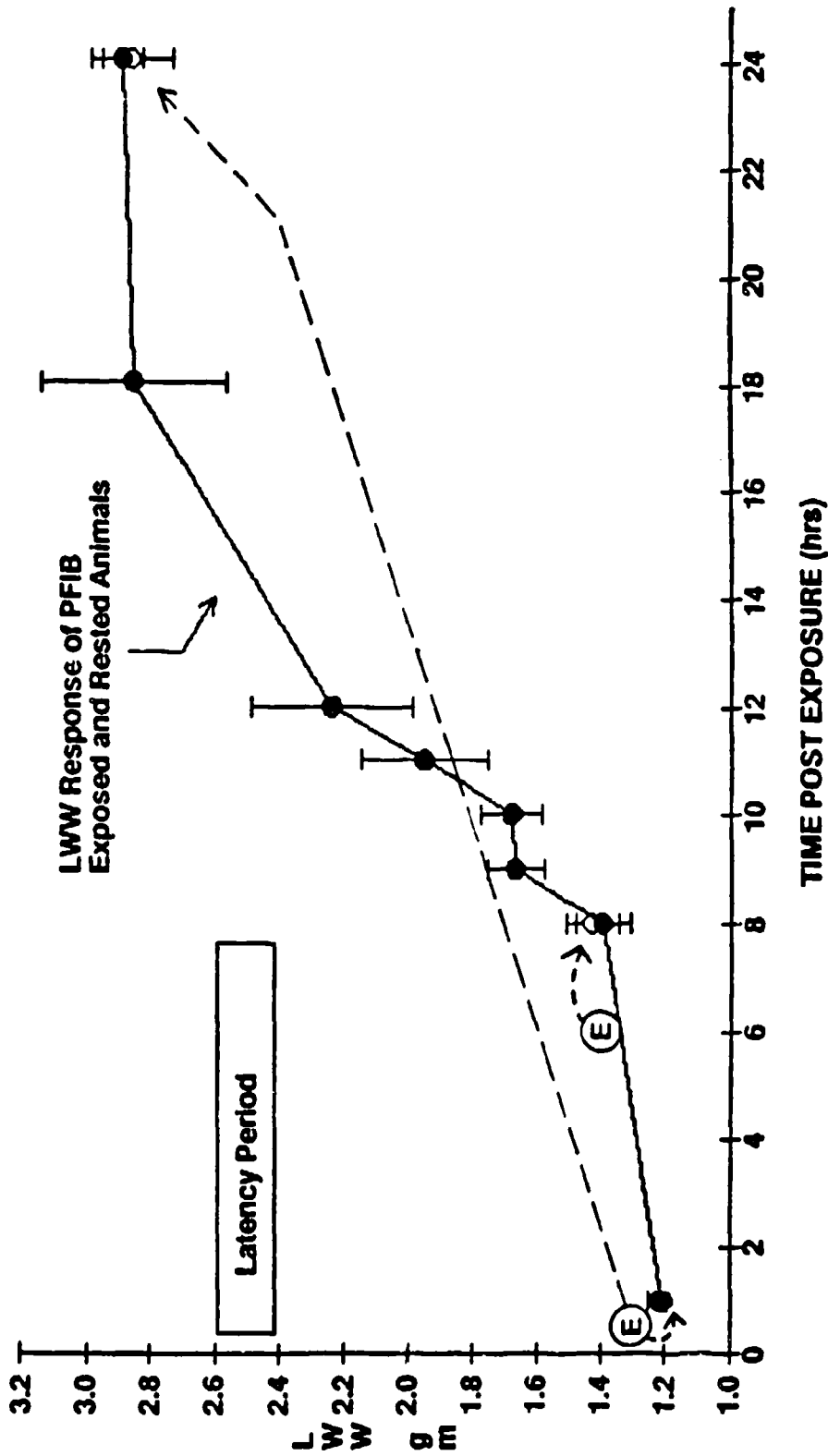

Figure 9. Lung wet weight (LWW) response of animals exercised during the latency period after being exposed to 100 mg/M³ PFIB for 10 min. (—) = PFIB exposed and rested LWW values. (E) = Time of post PFIB exercise. (---) = Resulting LWW value after post exposure exercise. No significant potentiation of injury occurred if animals were exercised during the latency period.

**EFFECTS OF POST EXPOSURE EXERCISE
PERFORMED DURING THE LATENCY PERIOD
AFTER EXPOSURE TO 100 MG/M PFIB X 10 MIN**

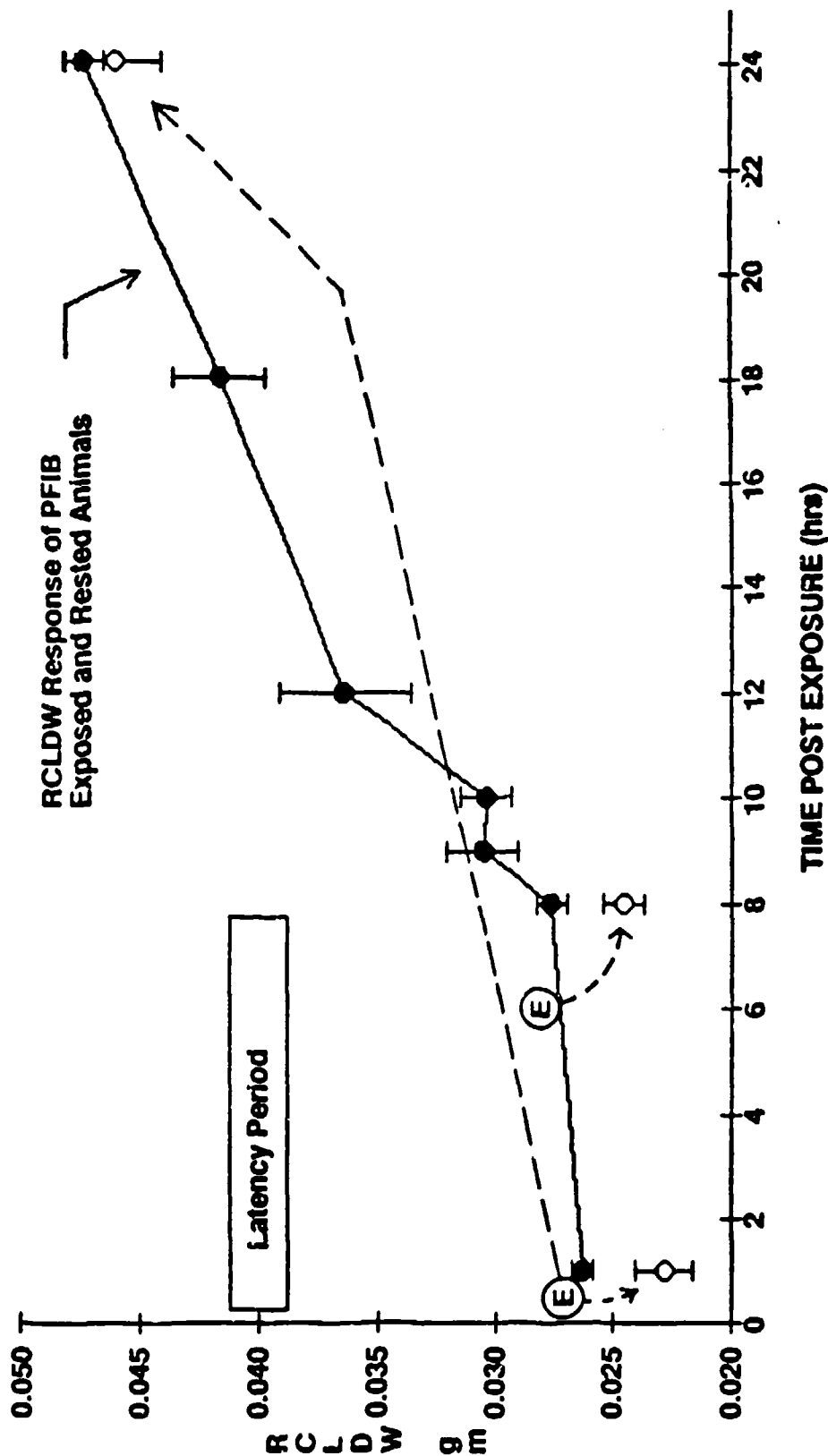

Figure 10. Right cranial lobe dry weight (RCLDW) response of animals exercised during the latency period after being exposed to 100 mg/M³ PFIB for 10 min. (—) = PFIB exposed and rested RCLDW values. (E) = Time of post PFIB exercise. (---) = Resulting RCLDW value after post exposure exercise. No significant potentiation of injury occurred if animals were exercised during the latency period.

**EFFECTS OF POST EXPOSURE EXERCISE
PERFORMED DURING THE WINDOW OF SUSCEPTIBILITY
AFTER EXPOSURE TO 100 MG/M³ PFIB X 10 MIN**

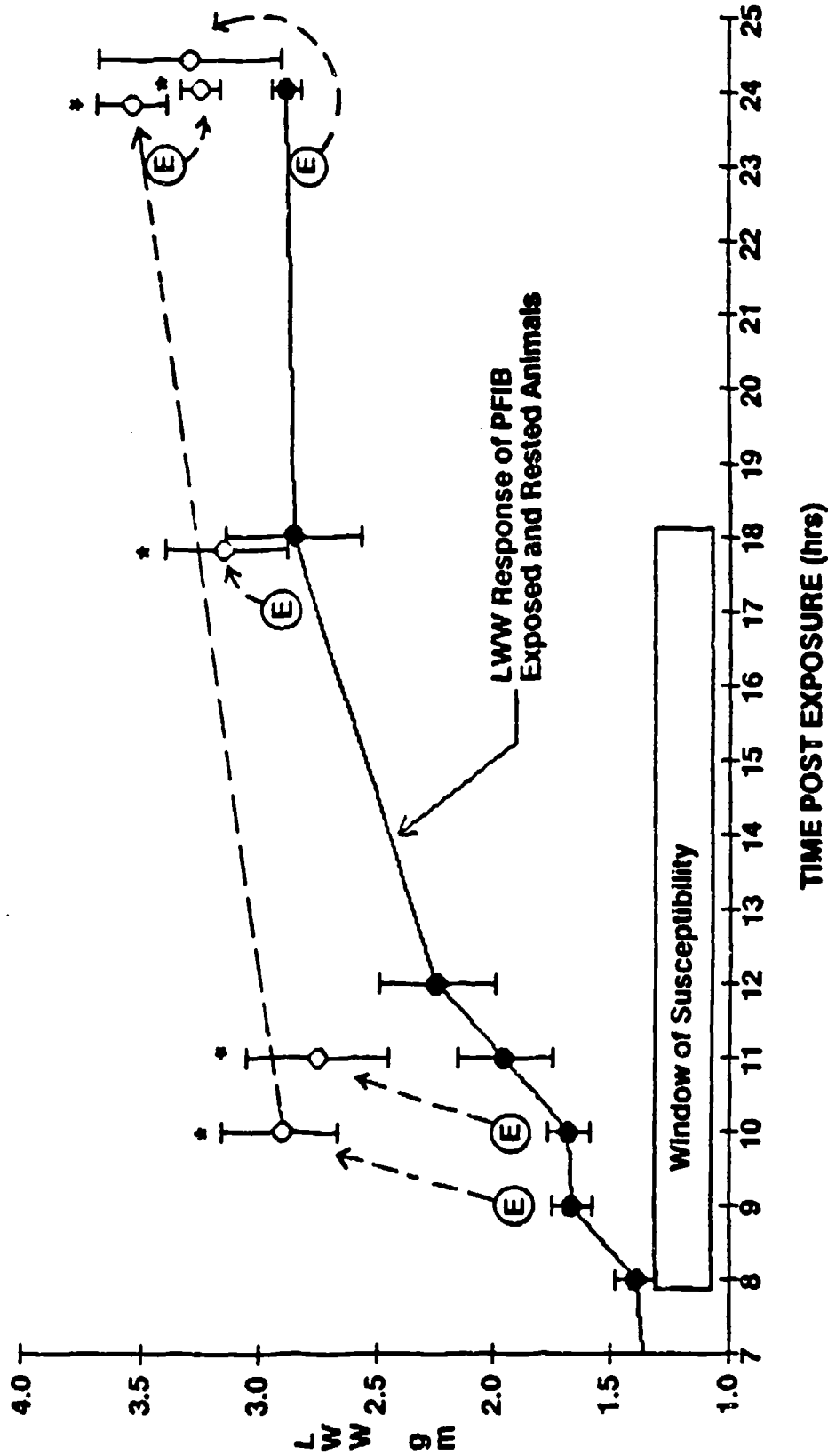

Figure 11. Lung wet weight (LWW) responses after exercise during the "window of susceptibility". (—) = PFIB exposed and rested LWW values. (E) = Time of post PFIB exercise. (---) = Resulting LWW value after post exposure exercise. (*) denotes significant increases in LWW above the PFIB exposed and rested condition at that particular sacrifice time point, ($P \leq 0.05$).

**EFFECTS OF POST EXPOSURE EXERCISE
PERFORMED DURING THE WINDOW OF SUSCEPTIBILITY
AFTER EXPOSURE TO 100 MG/M PFIB X 10 MIN**

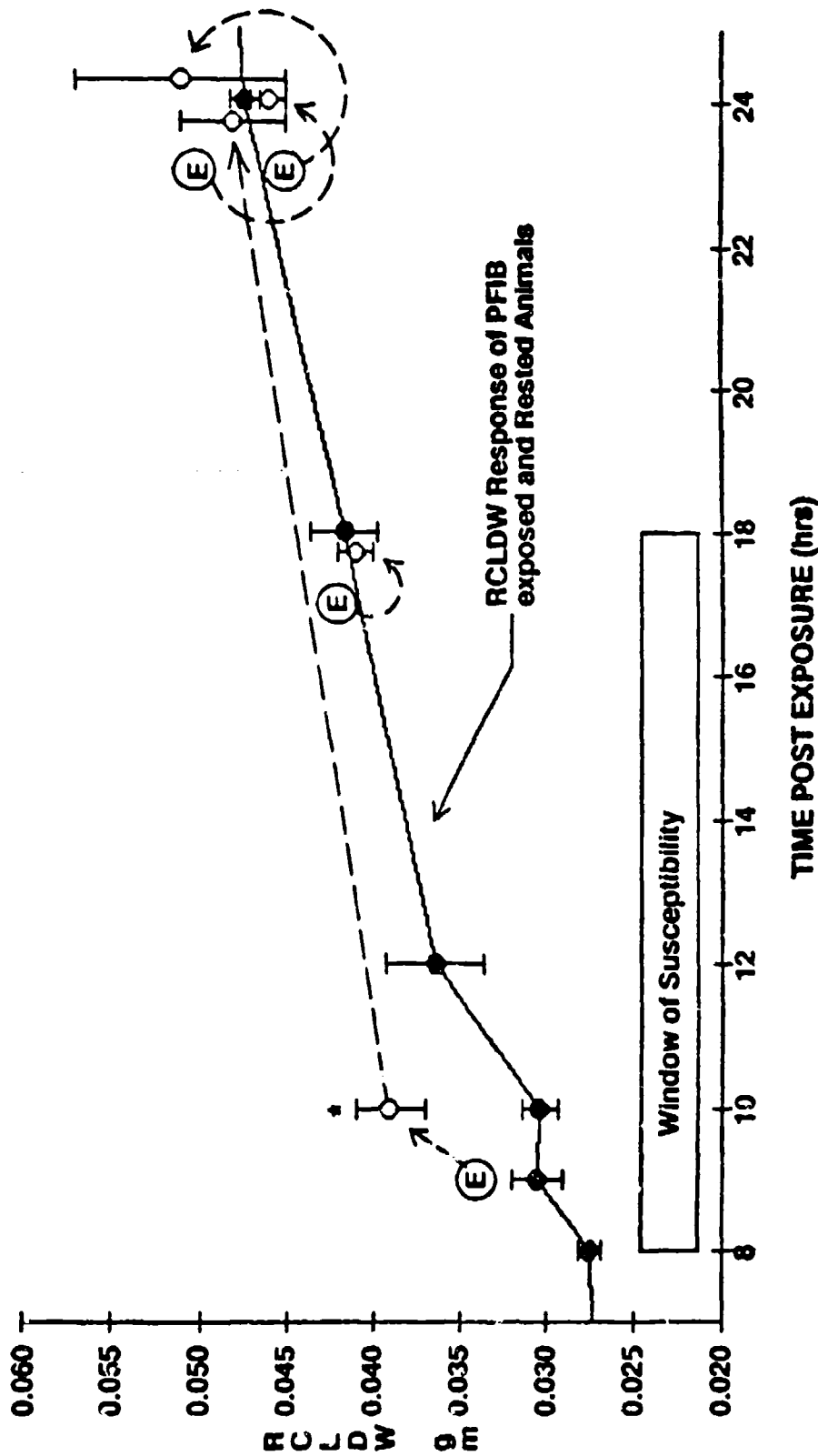

Figure 12. Right cranial lobe dry weight (RCLDW) responses after exercise during the "window of susceptibility". (—) = PFIB exposed and rested RCLDW values (E) = Time of post PFIB exercise. (---) = Resulting RCLDW value after post exposure exercise. (*) denotes significant increases in RCLDW above the PFIB exposed and rested condition at that particular sacrifice time point, ($P \leq 0.05$).

after exposure to PFIB also did not affect LWW or RCLDW values measured 48 hr post PFIB exposure relative to values measured on PFIB exposed and rested animals that were examined at the 48 hr time point (data not shown).

Based on the above findings, an approximate "window of susceptibility" to the potentiating effects of post-exposure exercise on PFIB-induced lung injury is indicated on Figures 11 and 12. It remains possible that the actual window of susceptibility becomes "open" sometime between 6 and 9 hours after exposure to 100 mg/M³ PFIB and that it may actually close following the inhalation of this mass concentration sometime after the illustrated 18 hr post-exposure time point.

Lung Gravimetric Changes/Two Exercise Bouts: When animals were exercised 9 hr after exposure to 100 mg/M³ PFIB, subjected to another exercise bout 23 hr after the PFIB exposure, and then subsequently sacrificed at the 24 hr post-exposure time point, no further potentiation of injury, as indexed by LWW or RCLDW, occurred beyond that observed with animals that were exercised 9 hr post-exposure only and then sacrificed 24 hr after the PFIB exposure, Figures 11 and 12. These findings suggest that the "window of susceptibility" to the potentiating effects of exercise is not extended when exercise is performed at an earlier post-exposure time when exercise can cause a potentiation in expression of lung injury.

Lung Histopathology: Lung histopathology scores from the above exercise studies are summarized in Tables 13 to 17. With the exception of fibrin accumulations, the distribution, severity, and intensity indices of the other histopathologic endpoints for the lungs of exercised rats and their rested counterparts were usually similar. Significant additional accumulations of fibrin, however, were observed in the lungs of animals that were exercised 9 hr after exposure to 100 mg/M³ PFIB and sacrificed 10 hr post-exposure, Table 14, compared to PFIB exposed and rested animals that were sacrificed 10 hr after the PFIB exposure. Compared to PFIB exposed and rested control animals, significant additional accumulations of fibrin were also observed when rats were exercised 10 hr after exposure to this concentration of PFIB and then sacrificed at 11 hr post exposure. No additional fibrin accumulations attributable to exercise were detected at any of the other post-exposure exercise time points. Except for a significantly elevated score for edema fluid severity measured 18 hr post PFIB exposure after animals were exercised 17 hr after exposure, no other histological abnormalities were observed due to post-exposure exercise when compared to resting post PFIB exposure control values. Lastly, the histopathologic indices for the lungs from rats that were exercised 9 hr after PFIB exposure, exercised again at 23 hr post-exposure, and subsequently sacrificed 24 hr after exposure were not significantly different from those indices obtained from the lungs of animals that were exercised 9 hr after PFIB exposure and then allowed to rest until the 24 hr sacrifice time.

<u>100 mg/M³ PFIB</u>		Severity	Intensity
Post Exposure Sacrifice Time	Post Exposure Exercise Time		
Edema Fluid			
1 Hr	0 Hr	0	0
8 Hr	6 Hr	1.0 ± 0.6	0.8 ± 0.5
10 Hr	9 Hr	2.0 ± 0.0	2.2 ± 0.2
11 Hr	10 Hr	1.8 ± 0.2	2.4 ± 0.2
18 Hr	17 Hr	2.6 ± 0.3	3.0 ± 0.0
24 Hr	9 Hr	1.8 ± 0.5	2.4 ± 0.6
24 Hr	23 Hr	2.6 ± 0.2	3.4 ± 0.2
24 Hr	9 & 23 Hr	2.0 ± 0.0	3.0 ± 0.0
48 Hr	47 Hr	2.2 ± 0.2	2.0 ± 0.0

Table 13. Histopathologic scores for the accumulation of edema fluid from the lungs of animals exercised at designated times after nominal 100 mg/M³ PFIB exposures, (see text for histopathologic scoring details). (*) indicates significant difference between post PFIB exposure exercise groups and PFIB exposed and rested control groups. (p ≤ 0.05).

<u>100 mg/M³ PFIB</u>		Distribution	Severity	Intensity
Post Exposure Sacrifice Time	Post Exposure Exercise Time			
1 Hr	0 Hr	0	0	0
8 Hr	6 Hr	0	0	0
10 Hr	9 Hr	2.6 ± 0.2*	2.6 ± 0.2	2.0 ± 0.0*
11 Hr	10 Hr	2.4 ± 0.4*	2.6 ± 0.2*	2.2 ± 0.2*
18 Hr	17 Hr	2.2 ± 0.6	2.4 ± 0.6	1.6 ± 0.4
24 Hr	9 Hr	2.8 ± 0.2	3.2 ± 0.4	2.0 ± 0.0
24 Hr	23 Hr	2.2 ± 0.6	2.6 ± 0.7	2.4 ± 0.6
24 Hr	9 & 23 Hr	3.0 ± 0.0	3.0 ± 0.3	2.0 ± 0.0
48 Hr	47 Hr	0	0	0

Table 14. Histopathologic scores of the accumulation of fibrin from the lungs of animals exercised at designated times after nominal 100 mg/M³ PFIB exposures, (see text for histopathologic scoring details). (*) indicates significant difference between post PFIB exposure exercise groups and PFIB exposed and rested control groups, (p ≤ 0.05).

<u>100 mg/M³ PFIB</u>		Distribution	Severity	Intensity
Post Exposure Sacrifice Time	Post Exposure Exercise Time			
Polymerphuclear Leukocytes				
1 Hr	0 Hr	0	0	0
8 Hr	6 Hr	0	0	0
10 Hr	9 Hr	1.6 ± 0.4	1.2 ± 0.4	1.0 ± 0.3
11 Hr	10 Hr	1.2 ± 0.5	1.0 ± 0.4	0.8 ± 0.4
18 Hr	17 Hr	1.6 ± 0.4	1.6 ± 0.4	0.8 ± 0.2
24 Hr	9 Hr	2.4 ± 0.3	2.2 ± 0.4	1.6 ± 0.2
24 Hr	23 Hr	1.8 ± 0.5	1.4 ± 0.7	1.4 ± 0.4
24 Hr	9 & 23 Hr	2.4 ± 0.2	2.2 ± 0.2	2.0 ± 0.0
48 Hr	47 Hr	0.4 ± 0.4	0.4 ± 0.4	0.2 ± 0.2

Table 15. Histopathologic scores for the occurrence of polymerphuclear leukocytes in the lungs of animals exercised at designated times after nominal 100 mg/M³ PFIB exposures, (see text for histopathologic scoring details). (*) indicates significant difference between post PFIB exposure exercise groups and PFIB exposed and rested groups, (p ≤ 0.05).

100 mg/M³ PFIB		Distribution	Severity	Intensity
Post Exposure Sacrifice Time	Post Exposure Exercise Time			
Macrophages				
1 Hr	0 Hr	0	0	0
8 Hr	6 Hr	1.0 ± 0.6	0.5 ± 0.3	0.5 ± 0.3
10 Hr	9 Hr	2.8 ± 0.2	2.8 ± 0.2	2.0 ± 0.0
11 Hr	10 Hr	2.0 ± 0.3	2.0 ± 0.0	2.0 ± 0.0
18 Hr	17 Hr	2.8 ± 0.2	2.4 ± 0.2	2.0 ± 0.0
24 Hr	9 Hr	3.0 ± 0.0	2.2 ± 0.2	2.0 ± 0.0
24 Hr	23 Hr	3.0 ± 0.0	2.8 ± 0.2	2.8 ± 0.2
24 Hr	9 & 23 Hr	3.0 ± 0.0	2.6 ± 0.2	2.0 ± 0.0
48 Hr	47 Hr	4.0 ± 0.0	3.4 ± 0.3	2.8 ± 0.2

Table 16. Histopathologic scores from the occurrence of macrophages in the lungs of animals exercised at designated times after nominal 100 mg/M³ PFIB exposures, (see text for histopathologic scoring details). (*) Indicates significance difference between post PFIB exposure exercise groups and PFIB exposed and rested groups, (p ≤ 0.05).

100 mg/M ³ PFIB		Distribution	Severity
Post Exposure Sacrifice Time	Post Exposure Exercise Time	Perivascular Congestion	
1 Hr	0 Hr	0	0
8 Hr	6 Hr	0	0
10 Hr	9 Hr	0	0
11 Hr	10 Hr	0.8 ± 0.5	0.8 ± 0.5
18 Hr	17 Hr	0.4 ± 0.4	0.6 ± 0.6
24 Hr	9 Hr	0.2 ± 0.2	0.6 ± 0.6
24 Hr	23 Hr	0	0
24 Hr	9 & 23 Hr	0	0
48 Hr	47 Hr	0	0

Table 17. Histopathologic scores of perivascular congestion in the lungs of animals exercised at designated times after nominal 100 mg/M³ PFIB exposures. (see text for histopathologic scoring details). (*) Indicates significant difference between post PFIB exposure exercise groups and PFIB exposed and rested groups. (p ≤ 0.05).

Work Performance. Work performance, as indexed by maximum oxygen consumption (VO_{2max}), was significantly reduced as of 9 hr after exposure to 100 mg/M³ PFIB for 10 minutes, Table 18, whereas no significant evidence for a reduction in work performance was found during exercise at earlier post-exposure times. The post-exposure reductions in work performance maximally and equivalently

100 mg/M³ PFIB	
Post Exposure Exercise Time	Maximum Oxygen Consumption (Percent change from pre-exposure values)
0 HR	-3.6 ± 1.9
6 Hr	-1.8 ± 3.7
9 Hr	-18.3 ± 5.2*
10 Hr	-27.3 ± 6.7*
17 Hr	-44.6 ± 5.6*
23 Hr	-41.4 ± 8.9*
9 & 23 Hr	-17.2 ± 4.9*, -43.5 ± 4.0*
47 Hr	-32.4 ± 2.0*

Table 18. Percent change in the maximum oxygen consumption (VO_{2max}) values compared to the mean of several pre values. Each animal serves as its own control. (*) indicates significant difference of the mean of post-exposure values compared to the mean of pre-exposure values ($p \leq 0.05$).

occurred at the 17 and 23 hr post-exposure time points. Substantial reductions in work performance capacity persisted for at least 47 hr after exposure to 100 mg/M³ PFIB. Also shown in Table 18, an exercise bout performed 9 hr after PFIB exposure did not significantly affect the work performance capacity of rats measured during the performance of a second subsequent exercise bout performed 23 hr after exposure.

The PFIB-associated reductions in VO_{2max} , Table 18, appeared to be proportionately related to the degree of pulmonary edema present at the time the "ramp" exercise bout was performed, as indexed by increases in LWW, Figures 13 and 14.

RELATIONSHIP OF LUNG WET WEIGHT AND DEGRADATION OF WORK PERFORMANCE AFTER EXPOSURE TO 100 mg/M PFIB FOR 10 MIN

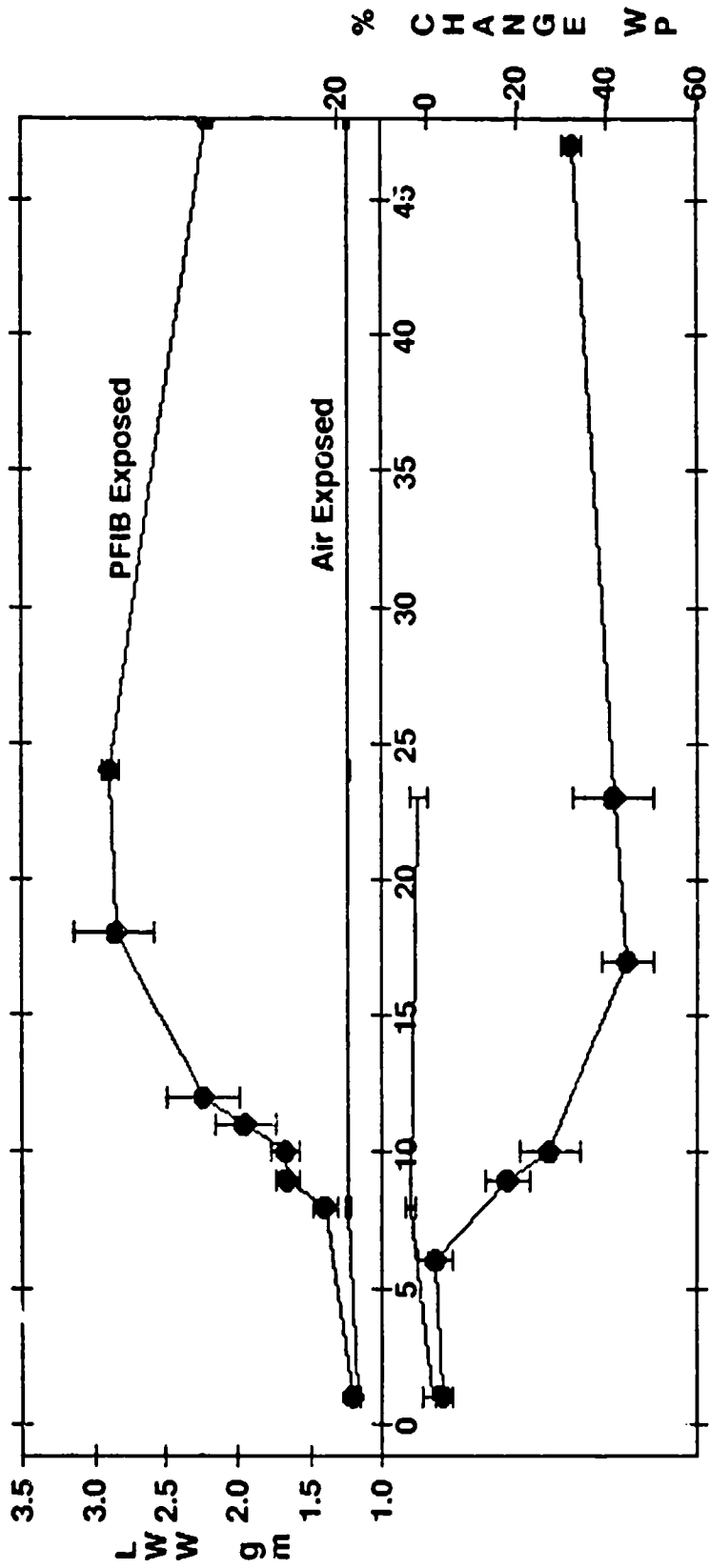

TIME POST EXPOSURE (hr)

Figure 13. Post exposure degradation of work performance (% change VO_{2max}) of rats exposed to either air x 10 min or 100 mg/M³ PFIB for 10 min. Also presented are the lung wet weight (LWW) responses of rats exposed to 100 mg/M³ PFIB for 10 min and rested after exposure. Each point represents the mean and SEM of 5 to 6 animals.

**PERCENT CHANGE VO₂max
IN RELATION TO LUNG WET WEIGHT AFTER EXPOSURE TO PFIB**

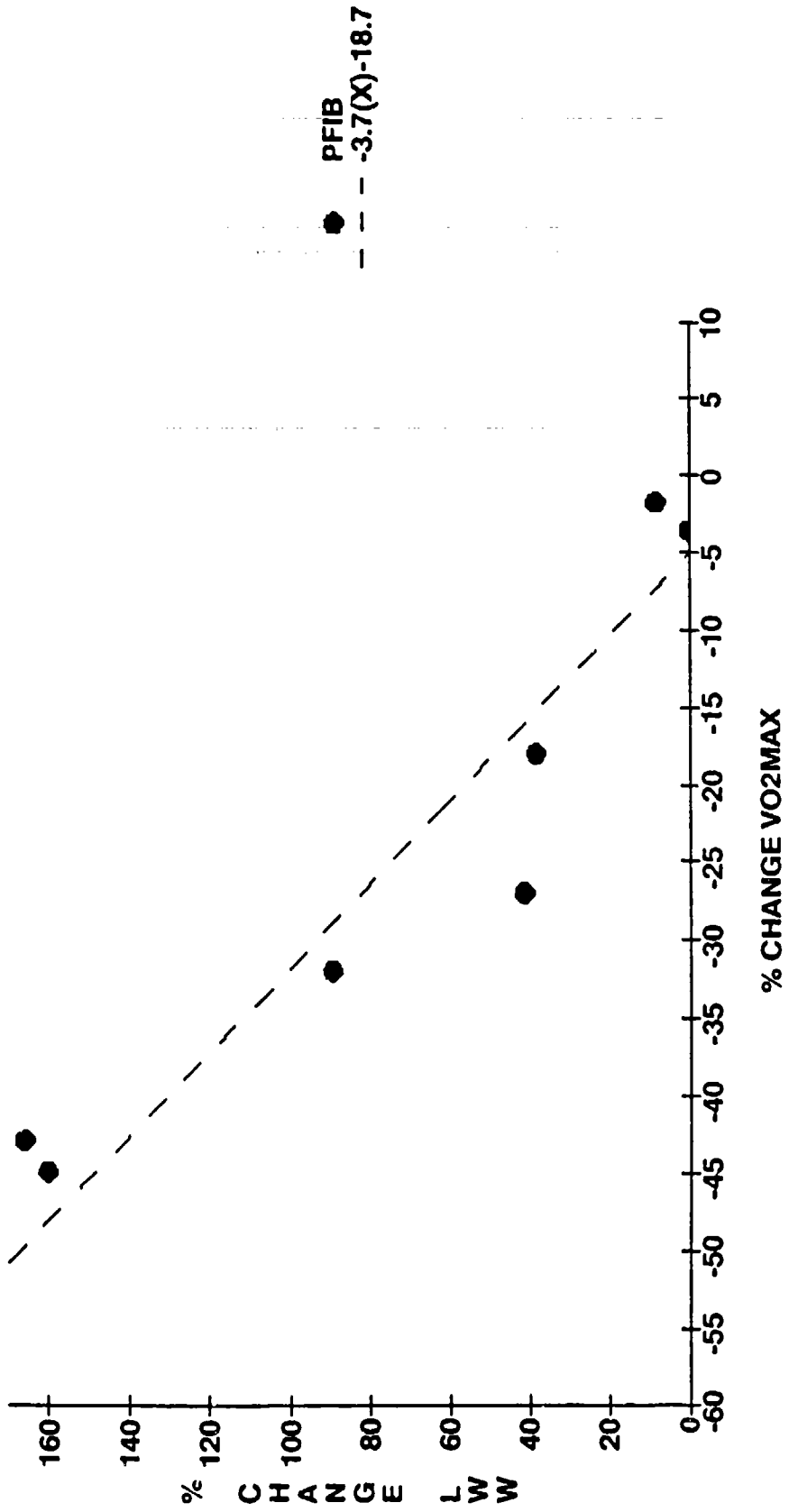

Figure 14. Post exposure degradation of work performance (% change VO_{2max}) as a function of lung wet weight (LWW). Each point represents the mean percent change of maximum oxygen consumption (VO_{2max}) measured at various times post 100 mg/M³ PFIB and plotting these values against corresponding mean values measured on separate PFIB exposed but rested animals sacrificed at the same sacrifice time.

PFIB Electron Microscopic Studies

Our observations regarding the acute ultrastructural changes that occur in the lung following PFIB exposure are summarized by the micrographs presented as Figures 15 A-D through Figures 18 A-D.

Figures 15A-D show electron micrographs of the alveolar region as of 1 hr post-exposure to 100 mg/M³ PFIB for a 10 min duration. Figure 15A is typical appearing lung parenchyma showing the presence of neutrophils (N) and blood monocytes (M) in blood capillaries. While neutrophils and blood monocytes can occasionally be observed in the capillaries of normal alveolar tissue (micrographs not shown), their presence following PFIB exposure is markedly more abundant. Figure 15B shows a large epithelial distension (arrow head) which contains numerous lamellar structures (L) in close proximity to a Type II cell (II). Epithelial blebs are also present (*). Figure 15C is a micrograph of a typical alveolar macrophage (AM), a normal appearing lipid-containing interstitial fibroblast (LIF), and a Type II (II) cell. The macrophage with its plethora of phagolysosomes, many of which contain lamellar type structures (arrows), appears to be activated. Also present are numerous micro-blebs (*) in the endothelial cells. Of significance, blebbing of epithelial and endothelial cells appears to follow the same kinetic course, i.e., blebbing of alveolar epithelial and endothelial cells occurs concurrently. Figure 15D shows some evidence of early interstitial edema (E), which was not detectable using lung gravimetric endpoints. Damaged endothelial cells (arrow) and blebs (*) result in unusual distortions.

Figures 16A-D are electron micrographs of lung parenchyma 3 hr following a 100 mg/M³ PFIB exposure. Figures 16A and 16B again show numerous abnormal accumulations of neutrophils (N) and blood monocytes (M) in the pulmonary capillaries. Type II cells appear to be expelling lamellar bodies (L) into the alveolar space (see inset). The proximity of an alveolar macrophage (AM) to one of the Type II cells is of potential significance, Figure 16A. Figure 16C is a septal region showing the presence of lamellar structures (arrow heads) in an unusual, subepithelial location. Endothelial blebs (*) are also present. Figure 16D is alveolar parenchyma showing the presence of epithelial and endothelial cell blebs (*) and a normal appearing lipid-containing interstitial fibroblast (LIF).

Figures 17A-D are electron micrographs of the alveolar region 1 hr after exposure to 200 mg/M³ PFIB for a 10 min duration. Figure 17A shows a massive herniation (H) of an epithelial cell with numerous endothelial and epithelial blebs (*). Evidence of interstitial edema is also present (E). Figure 17B shows destruction of Type I cell cytoplasm leaving only the nucleus (black arrow). The epithelial surface of this alveolus is essentially denuded (open arrows). Also evidence of edema (E) and endothelial blebbing (*) is observed. Figure 17C shows an abnormal blood capillary endothelial fenestration (F) corrupting the endothelial blood barrier (see inset). An endothelial bleb (*) is also present. Figure 17D shows an opening of the capillary endothelium (brackets) that has resulted in the introduction of vascular contents into the interstitial compartment. In this case, a blood monocyte (M) is partially in the capillary and partially in the interstitial space in close proximity to a lipid-containing

Figure 15A. Typical appearing lung parenchyma showing occasional neutrophil (N) and blood monocyte (M) in blood capillaries.

Figure 15B. Large epithelial distension (arrow head) which contains numerous lamellar structures (L) in close proximity to Type II cell (II). Epithelial blebs are also present (*).

Figure 15C. Typical alveolar macrophage (AM), lipid-containing interstitial fibroblast (LIF), and Type II (II) cell. Note the activated appearance of the macrophage and its plethora of phagolysosomes, many which contain lamellar type structures (arrows). Also present are numerous micro-blebs (*) in the endothelial cells.

Figure 15D. shows evidence of parenchymal edema (E). Note unusual distortion of endothelial cell (arrow) and blebs (*).

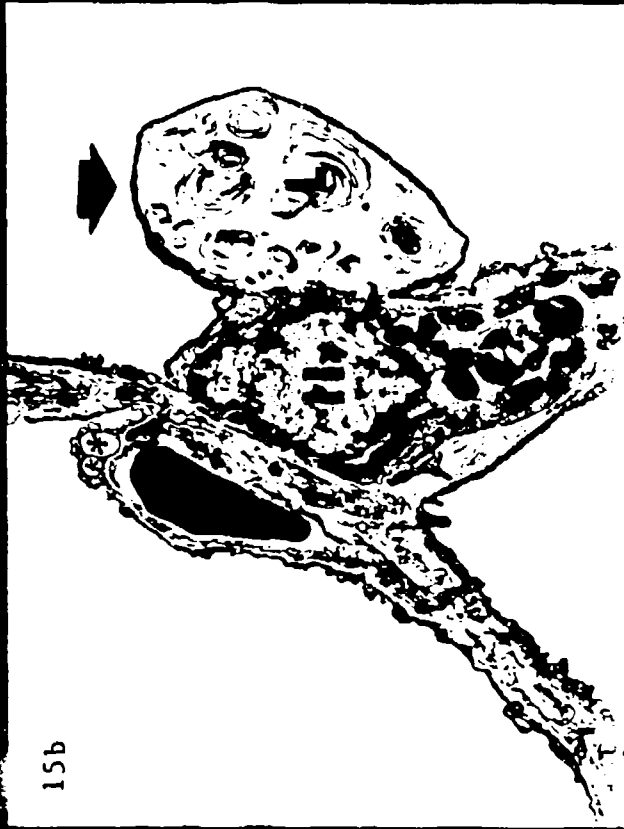

Figure 16A and 16B. Numerous neutrophils (N) and blood monocytes (M) in the capillaries. Type II cells appear to be expelling lamellar bodies (L) into the alveolar space (see inset). Note proximity of alveolar macrophage (AM) to one of the Type II cells.

Figure 16C. Septal region showing the presence of lamellar structures (arrow heads) in an unusual, sub-epithelial location. Endothelial blebs (*) are also present.

Figure 16D. Alveolar parenchyma showing the presence of epithelial and endothelial cell blebs (*) and a normal lipid-containing interstitial fibroblast (LIF).

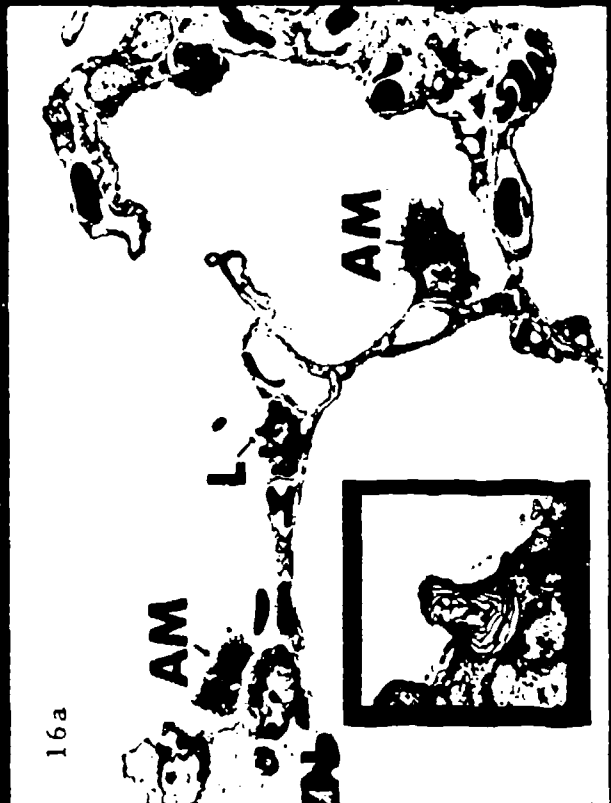

Figure 17A. Massive herniation (H) of an epithelial cell with numerous endothelial and epithelial blebs (*). Evidence of interstitial edema is also present (E).

Figure 17B. Destruction of Type I cytoplasm leaving only the nucleus (black arrow). Note the epithelial surface is essentially denuded (open arrows). Also evidence of edema (E) and endothelial blebbing (*) is observed.

Figure 17C. Blood capillary endothelial fenestration (F) corrupting endothelial blood barrier (see inset). Endothelial bleb (*) is also present.

Figure 17D. Opening of capillary endothelium (brackets) exposing vascular contents to interstitial compartment. Note blood monocyte (M) is partially in the capillary and partially in the interstitial space in close proximity to lipid containing interstitial fibroblast (LIF). Also present are numerous endothelial and epithelial blebs (*) and interstitial edema (E).

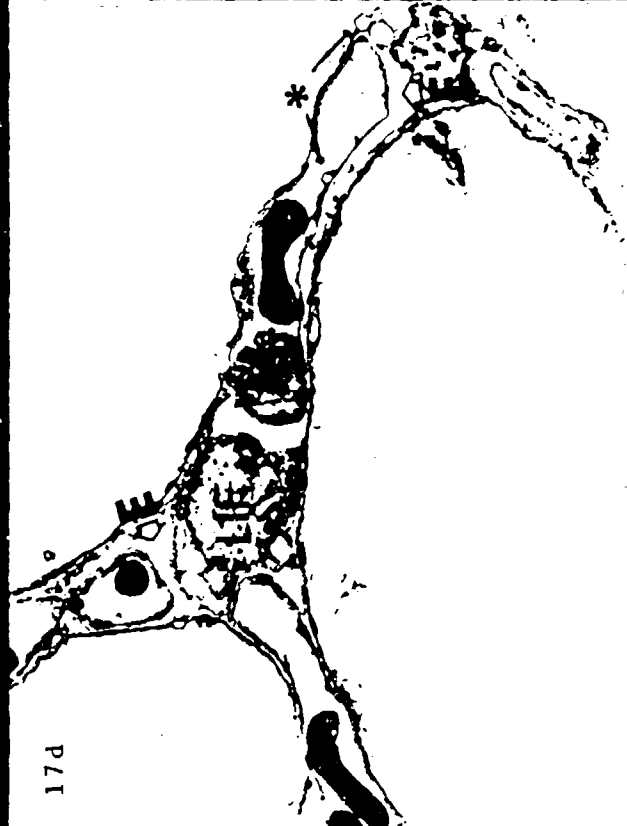

Figure 18A. Epithelial swelling and necrosis (arrow head), epithelial blebs (*), and apparent occlusion of a capillary by a swollen endothelial cell (S).

Figure 18B. Herniation (H) of Type II cell (II) and herniation of ciliated epithelial cell (see inset). Type I epithelial blebbing (*) is also apparent.

Figure 18C. Corruption of epithelial barrier (arrow heads) with subsequent exposure of interstitial compartment to the alveolar compartment (AL). Appearance of small amounts of fibrin (F) in the alveolus is evident. Alveolar macrophage (AM) appears to be phagocytizing fibrin, tubular myelin (T), and lipid (L). Also note presence of neutrophil (N).

Figure 18D. Massive interstitial edema (E).



interstitial fibroblast (LIF). Also present are numerous endothelial and epithelial blebs (*), and interstitial edema (E).

Figures 18A-D are electron micrographs of lung parenchyma 3 hr post 200 mg/M³ PFIB exposure. Figure 18A shows epithelial swelling and necrosis (arrow head), epithelial blebs (*), and apparent partial occlusion of a capillary by swollen endothelial cells (S), which have an unusually fine cytoplasmic appearance. Figure 18B shows herniation (H) of a Type II cell (II). Such herniation also occurs with epithelial cells along the conducting airways, as shown by the herniation of a ciliated epithelial cell in the inset of Figure 18B. Type I epithelial blebbing (*) is also apparent. Figure 18C shows the corruption of epithelial barrier (large arrow heads) with subsequent exposure of the vascular and interstitial compartments to the alveolar space compartment (AL). Fibrin (F) in the alveoli was also evident in these samples. An alveolar macrophage (AM) appear to be phagocytizing fibrin, tubular myelin (T), and lipid (L). Figure 18D shows massive interstitial edema (E).

Overall, the above ultrastructural observations have suggested the following sequence of events following PFIB exposure: The earliest detectable evidence of injury is alveolar epithelial and endothelial cell blebbing. Alveolar epithelial blebbing progresses to cell herniation, cell necrosis, and cell exfoliation, all of which result in hyperpermeability of the alveolar epithelial barrier. Additionally, damaged Type II cells release their lamellar material into the alveolar space compartment as well as into the interstitial compartment. This process may result in an acute form of phospholipidosis. Endothelial cell damage results in a breach in the permeability status of the endothelial barrier. Vascular contents, accordingly, are provided direct access into the lung's interstitial region for subsequent translocation into the alveoli. Additionally, endothelial cell swelling may result in a mechanical occlusion of the pulmonary vascular bed. The early appearance of neutrophils and blood monocytes, which occurs concurrently with the early alveolar epithelial and endothelial blebbing, suggests that these migratory cells may play an important role in mediating the injurious response. Two cell types that appear to be relatively resistant to the toxic effects of PFIB exposure are the alveolar macrophages and interstitial lung fibroblasts.

Preliminary reports on the above findings have been presented elsewhere (Sebring et al, 1990; Lehnert and Stavert, 1990).

Lung Free Cell Response and Lavage Fluid Biochemistry Study

Lung Free Cell Numbers and Types. The percentages of alveolar macrophages (AM), polymorphonuclear leukocytes (PMN/POLYS), lymphocytes (LYMPHS), and monocytes (MONOS) in the lung free cell populations lavaged from control and PFIB exposed rats are summarized in Table 19.

	Differential Analysis of Lavaged Cells			
	% AM	%PMN	%Lymphs	%Monos
Control Rats	80.6 ± 9.1	8.0 ± 2.1	5.9 ± 2.4	5.5 ± 7.5
PFIB Exposed Rats	99.1 ± 1.2	0.8 ± 1.3	0.2 ± 0.2	< 0.2

Table 19. Differential analysis of lavaged cells from air exposed and animals exposed to nominal 100 mg/M³ PFIB atmospheres for 10 min.

Approximately 99% of the cells from the control lungs were AM. Twenty-four hours after PFIB exposure, only about 80% of the lavaged cells were AM with increases in PMN, lymphocytes, and monocytes accounting for the remaining balance of cells, Table 19, and Figures 19A and 19B. The absolute numbers of AM, PMN, lymphocytes, and monocytes lavaged from the control and PFIB exposed animals are summarized in Figure 20. Total numbers of cells lavaged from the two groups were not significantly different from one another (Controls: $7.4 \times 10^6 \pm 0.8 \times 10^6$ cells; PFIB: $5.1 \times 10^6 \pm 1.1 \times 10^6$ cells), although the total free cell numbers from the PFIB exposed rats tended to be lower, $p=0.10$. The numbers of AM harvested from the PFIB exposed rats also tended to be lower than AM numbers lavaged from control animals, $p=0.05$. [Note: these potential decreases may have been attributable, at least in part, to the escape of edema fluid from the trachea of PFIB exposed lungs prior to lavage.] PMN and lymphocytes were both significantly elevated following PFIB exposure, $P<0.03$ and <0.03 , respectively. Monocytes were also numerically elevated in the free cell populations following PFIB exposure. This study again points to a potential role of neutrophils and blood monocytes in the injurious response to PFIB. Additionally, the observation that AM numbers are not increased following PFIB exposure suggests that the increases in AM observed in the previously described histopathologic studies may not have been due to actual elevations in AM numbers. AM are usually found in the corners of the alveoli where they may not be readily discerned from epithelial cells in the normal lung, whereas their detectability may be increased if they become less adherent to the alveolar epithelial surface during a



Figures 19A-19B: Photomicrographs of cells lavaged from a control rat (A) and from a rat 24 hr after a 10 min exposure to 100 mg/m³ PFIB.

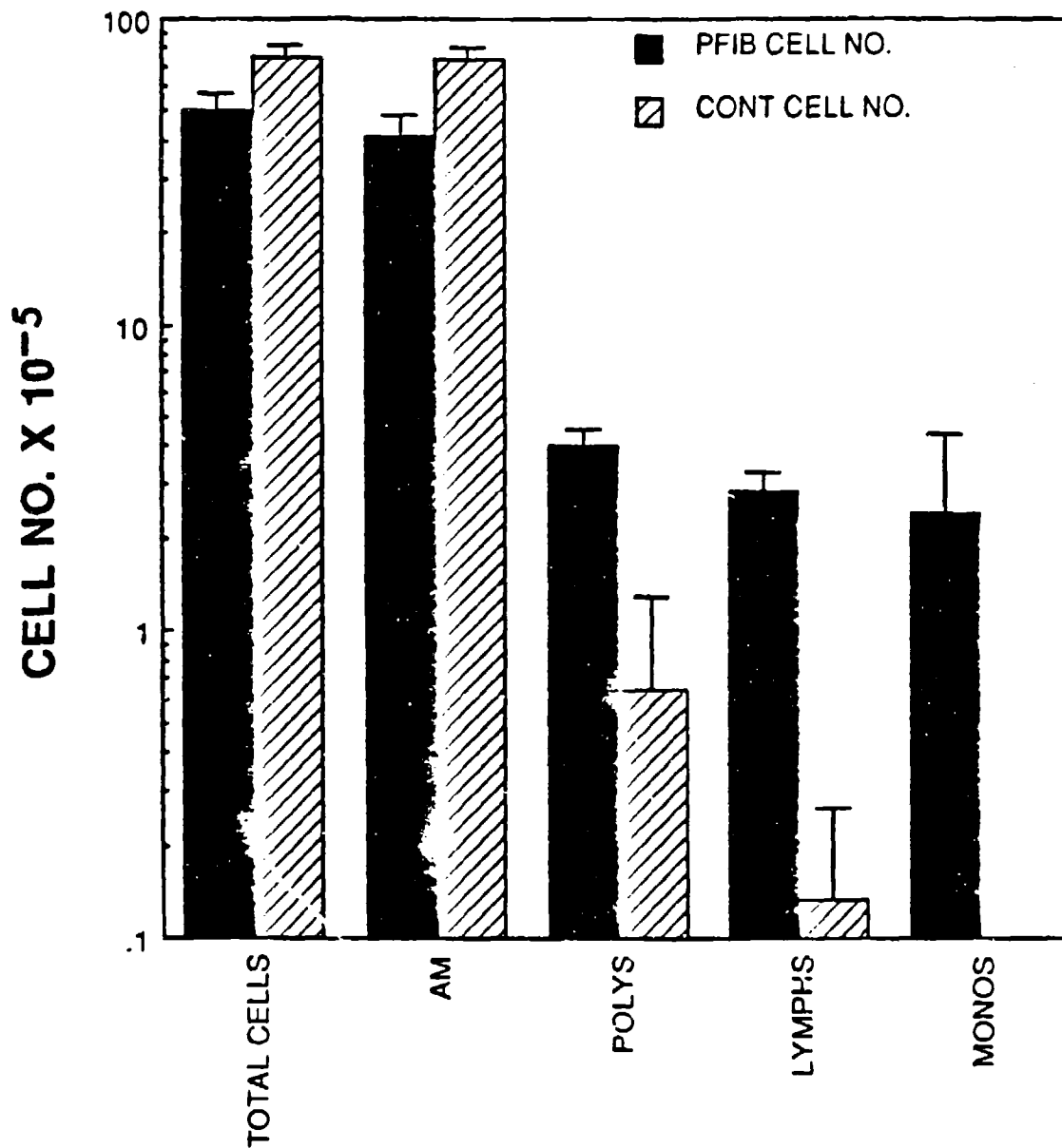

Figure 20. Absolute numbers of free cells and free cell types lavaged from control and PFIB-exposed rats. Values represent means \pm SEM.

condition such as pulmonary edema or in response to a toxic insult.

A preliminary report on these PFIB-induced lung free cell alterations has been presented elsewhere (Gurley et al, 1990).

Lung Lavage Fluid Biochemistry. Previous HPLC studies in our laboratory (Gurley et al, 1988; Gurley et al, 1989) have indicated that phospholipids normally elute before fraction 1 and in the trailing shoulder of fraction 11, and that proteins elute in fractions 2-9 and 11, Figures 21 and 22. Fractions 1 and 10 have been shown to be negative for protein and phospholipid. Also shown in Figure 22, transferrin elutes as fraction 3, albumin elutes as fraction 4, IgG (~150kDa) elutes in both fractions 5 and 6, and IgM (~600 kDa) elutes primarily in fraction 5. Of relevance to the analytical procedure for quantitating constituents in lavage fluids, the detected abundance of each fraction has been found to scale linearly with the volume of lavage fluid loaded onto the HPLC column, Figure 23. PFIB exposure (100 mg/M³ for 10 min) resulted in increases in the abundance of all resolved constituents as of 24 hr later with the exception of fraction 9, which remained essentially unchanged, Figure 24. The relative increases in the other constituents are summarized in Table 20. Transferrin (~85kDa, fraction 3) and albumin (~69kDa, fraction 4) were both comparably increased ~28- and ~26-fold, respectively. Much greater increases, i.e., ~100-fold, were found in fractions 5 and 6, which elute as immunoglobulins with standards. Of potential significance relative to indicators of lung damage, PFIB exposure resulted in the appearance of three new constituents, Fractions A, B, and C, in the lavage fluids, Figure 24. The results of this study demonstrate marked changes occur in the lung's extracellular fluid lining that are consistent with a loss in the integrity of the normal permeability status of the alveolar epithelial-capillary barrier. Additionally, this study suggests that the "effective pore" sizes that allow the translocation of blood compartment constituents into the alveoli following PFIB exposure are large enough to accommodate the passage of relative large molecules, including proteins as large as IgM. On the other hand, it remains possible that PFIB-induced increases in lavage fluid immunoglobulins could be related to the abnormal occurrence of lymphocytes in the lung's free cell population. Conceivably, the new fractions A, B, and C may be hallmark signatures of PFIB exposure.

A preliminary report on the above biochemical changes that occur following PFIB exposure has been presented elsewhere (Gurley et al, 1990).

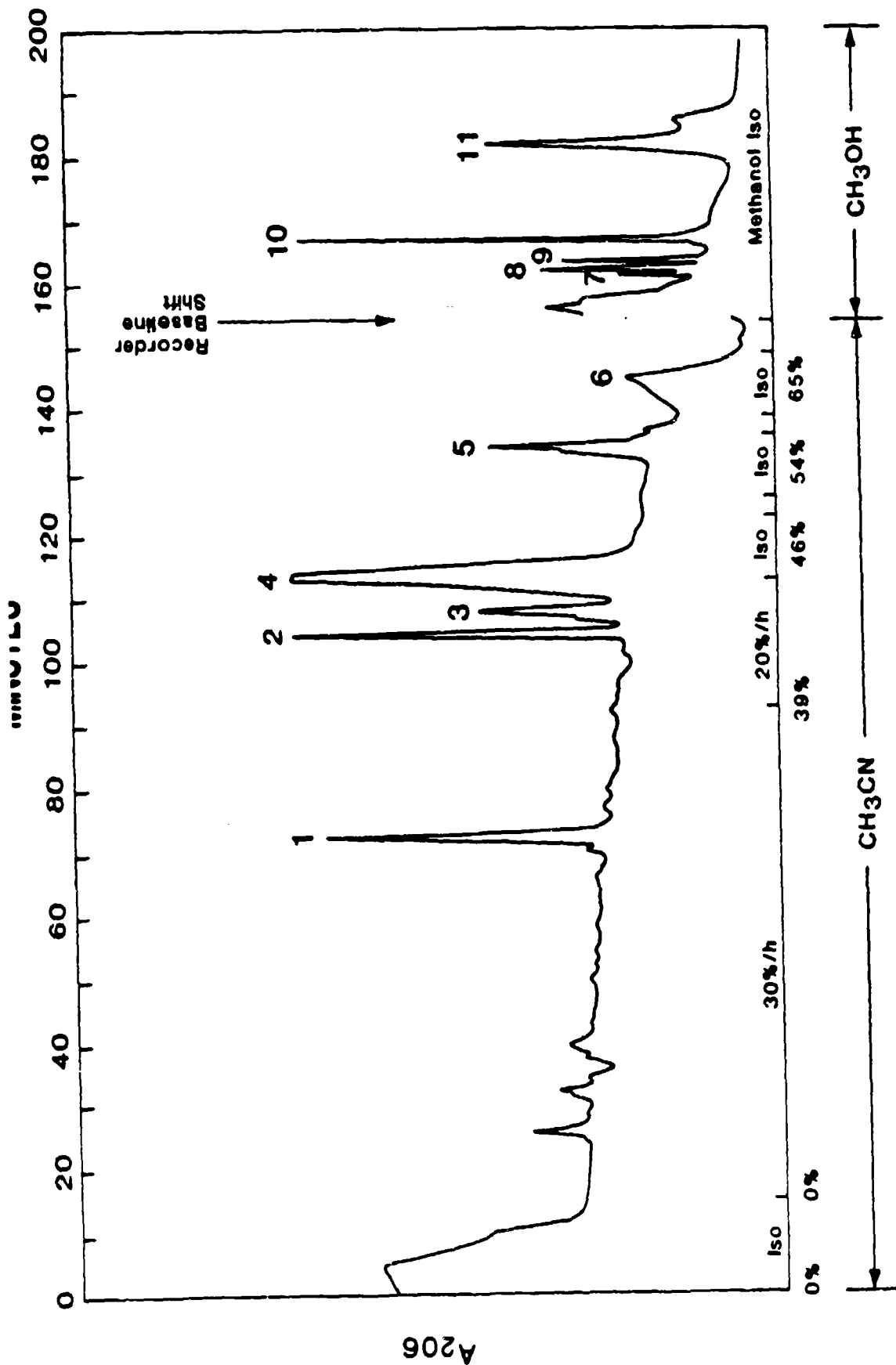

Figure 21. Elution of lavage fluid constituents from a μ Bondapak C₁₈ Radial-Pak column with a series of acetonitrile (CH₃CN) gradients and isocratic steps followed by a 100% methanol elution step. All elutions were made at flow rates of 1 ml/min with times shown at the top of the chromatogram. The increasing linear CH₃CN gradients are indicated as %/hr and the CH₃CN isocratic steps are indicated as Iso at the bottom of the chromatogram, as are the percentages of CH₃CN used. Isocratic methanol elution is also indicated at the bottom of the chromatogram.

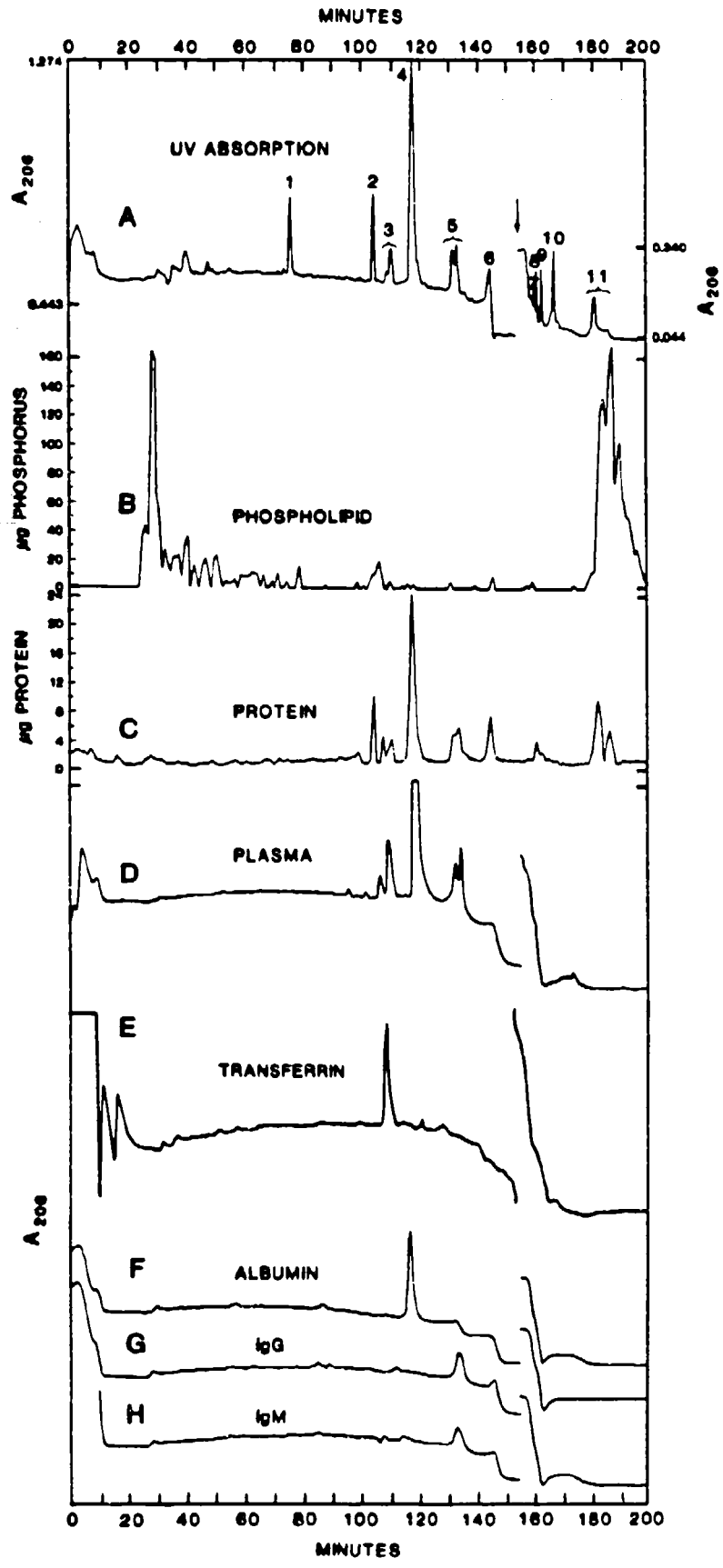

Figure 22. Analysis of phospholipid (B) (Fiske-Subarow technique) and protein (C) (Folin-Lowry technique) in lavage fluid fractions (A), and the elution profiles of rat plasma (D), transferrin (E), albumin (F), IgG (G), and IgM (H) using the same elution program described in Figure 21.

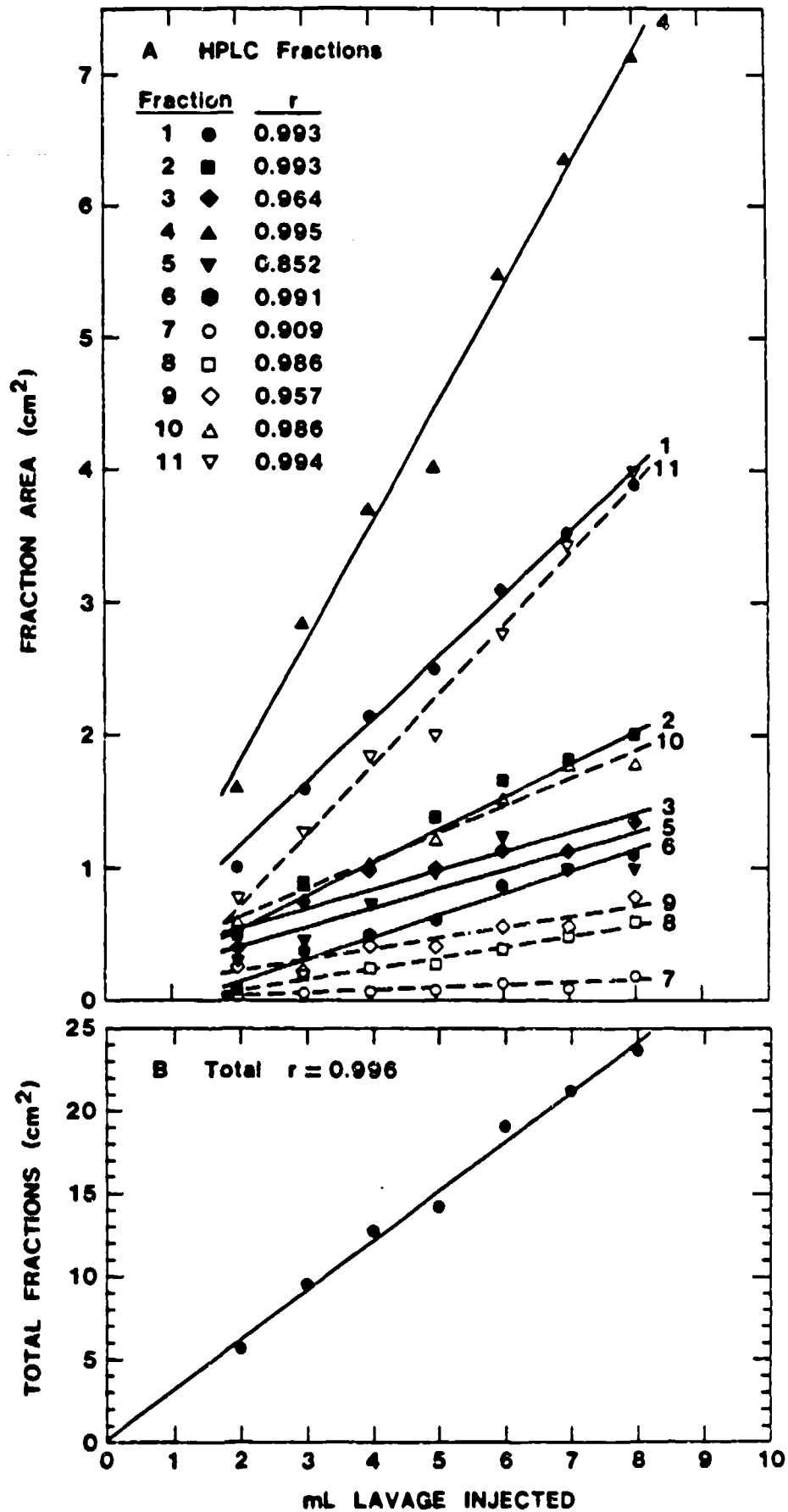

Figure 23. Linear relationship between sample load and the quantity of each fraction detected by the HPLC technique.

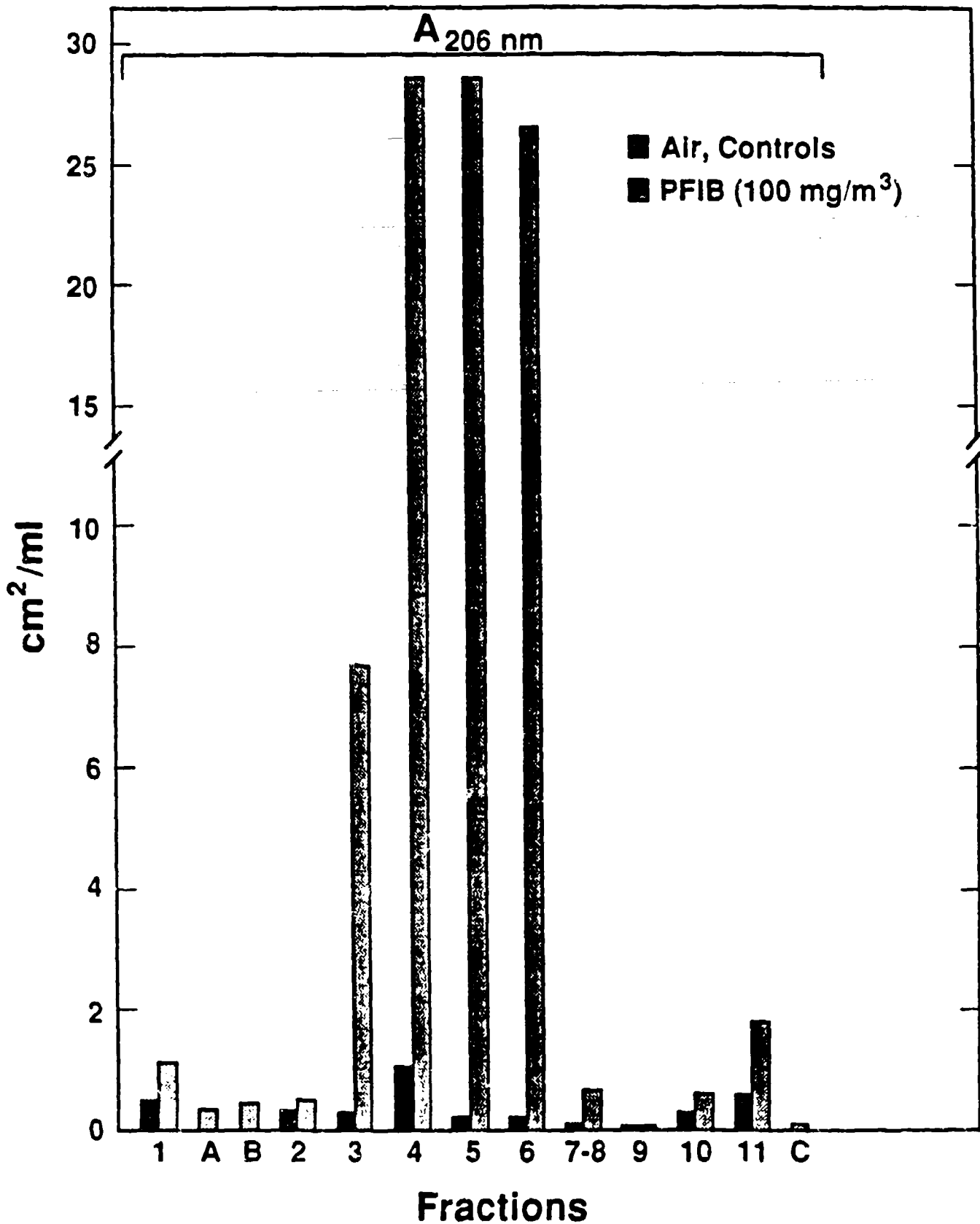

Figure 24. Relative abundance of constituents in the lavage fluids of control and PFIB exposed rats. Each fraction represents the mean value of three animals per exposure condition.

PART II. TFD STUDIES

Materials and Methods

Animals: Rats (250-280 gm) used in this component of the study were from the same commercial source as those used in the PFIB studies. All information previously provided about the care and use of the animals in the PFIB studies also pertains to the TFD studies.

Overview of Objectives and Approaches. Preliminary TFD concentration range finding studies were undertaken to assess the inhaled concentration-response characteristics of lung injury that occurs as of 24 hr after exposing rats to differing concentrations of TFD for 10 min durations. In these studies, groups of rats were exposed to either air, 127 mg/M³, 137 mg/M³, 147 mg/M³, 157 mg/M³, 167 mg/M³ or 177 mg/M³ TFD, Table 21. The animals in each exposure group were then sacrificed 24 hr after the exposure and their lungs were gravimetrically measured and prepared for histopathologic analysis. Studies of the kinetics of TFD-induced lung injury were performed to characterize the magnitudes of lung injury at various times after TFD exposure. In these studies, rats were exposed to either control air, or to 137 mg/M³ TFD for 10 min. This latter exposure concentration was selected for these more detailed analyses because our initial exposure studies suggested that the inhalation of the 137 mg/M³ mass concentration of TFD produces a level of lung injury that would be satisfactorily useful in the exercise potentiation and work performance incapacitation studies. Lung injury was assessed at various times after exposure, as indicated in Table 21, using lung gravimetric and histopathologic criteria. For the exercise potentiation component of this study, animals were exposed to 137 mg/M³ TFD for 10 min, exercised at various times after exposure, Table 21, and they were sacrificed either shortly after exercise or after a more extended time depending on the experimental question being addressed. During the exercise bout(s), metabolic data was obtained as previously described in the PFIB component of the project in order to determine how exposure to TFD may affect work performance capacity.

Atmosphere Generation and Characterization. An exposure system for delivering up to 200 mg/M³ of bis(trifluoromethyl)disulfide (TFD) to laboratory rats was designed and fabricated, Figure 25. TFD was purchased from PCR Research Chemicals, Gainesville, FL. TFD atmosphere generation took place in the same system used for the PFIB studies with the major modification being the fabrication of a heating system to generate sufficient vapor pressure within the TFD storage canister to access the neat agent and to also prevent condensation of neat agent within the delivery system. The heating system was fabricated from 3

TFD EXPOSURE MATRIX		
TFD CONCENTRATION-RESPONSE STUDIES		
TFD Nominal Exposure Concentration	Post-Exposure Sacrifice Times (Hr)	
127 mg/M ³	24	
137 mg/M ³	24	
147 mg/M ³	24	
157 mg/M ³	24	
167 mg/M ³	24	
177 mg/M ³	24	
TFD KINETIC STUDIES		
TFD Nominal Exposure Concentration	Post-Exposure Sacrifice Times (Hr)	
137 mg/M ³	1,2,4,5,8,24,48	
TFD EXERCISE STUDIES		
TFD Nominal Exposure Concentration	Post-Exposure Exercise Times	Post-Exposure Sacrifice Times (Hr)
137 mg/M ³	0 Hr	1
137 mg/M ³	1 Hr	2
137 mg/M ³	4 Hr	5
137 mg/M ³	4 Hr	24
137 mg/M ³	4 Hr	48
137 mg/M ³	23 Hr	24
137 mg/M ³	47 Hr	48
137 mg/M ³	4 & 47 Hr	48

Table 21. Bis(trifluoromethyl)disulfide (TFD) exposure matrix.

mm O.D. soft copper tubing, which surrounded the neat agent canister, glass neat agent delivery syringe, and the Teflon[®] delivery tubing. The copper tubing heater was insulated from the glovebox by being enclosed within a plexiglass heater container. Temperature within the heater enclosure was maintained at 37° C ± 0.3° C using a constant temperature water bath that pumped 100 ml·min⁻¹ heated water through the copper coils of the heater. The exposure system for TFD exposures, which consisted of an atmosphere generator, delivery tubing and valves, an animal exposure tube, and a charcoal absorbing bed, was the same as that used in the PFIB studies, as previously indicated. As in the PFIB studies, monitoring of the exposure atmosphere was accomplished using GC (the same system as used in the PFIB studies) and quantitatively diluted TFD as primary standards.

Metabolic Measurements. The metabolic measurements in the TFD studies were performed using protocols identical to those previously described for the PFIB studies.

Animal Sacrifices, Lung Gravimetric Measurements and Histopathology. Animals sacrifice protocols, lung gravimetric protocols, and lung tissue processing protocols used in the TFD component of the study were identical to those used in the PFIB investigations.

Semi-Quantitative Histopathology. Pathologic endpoints surveyed and grading system for quantitating these endpoints in the TFD studies were the same as those used in the PFIB studies.

Statistical Analysis. Statistical approaches used in the TFD studies were the same as those used in the PFIB studies.

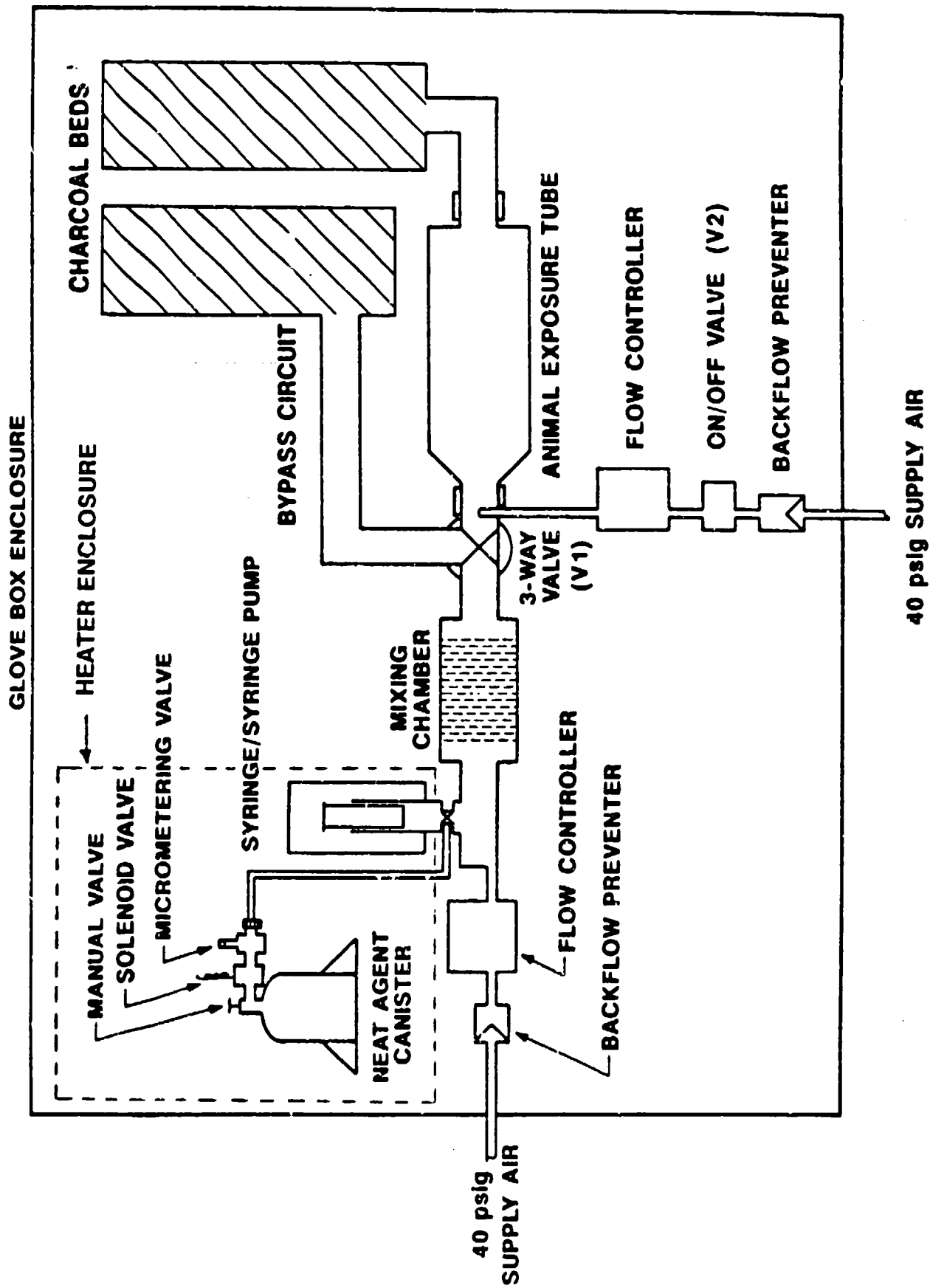

Figure 25. Bis(trifluoromethyl)disulfide (TFD) atmosphere exposure system. The system in contact with TFD is Teflon® or glass. Rats are exposed within whole body exposure tubes.

RESULTS

TFD Exposure Concentrations: The actual measured exposure concentrations for the nominal exposure concentrations of TFD studied are summarized in Table 22. Hereafter, all references to exposure concentration of TFD will refer to nominal concentrations.

EXPOSURE CONCENTRATIONS	
NOMINAL	ACTUAL (Mean ± SEM)
127 mg/M ³	131 ± 0.8 mg/M ³
137 mg/M ³	137 ± 0.1 mg/M ³ ⁴⁶ ± 0.4 mg/M ³
157 mg/M ³	155 ± 0.5 mg/M ³
167 mg/M ³	170 ± 1.3 mg/M ³
177 mg/M ³	176 ± 0.6 mg/M ³

Table 22. Mean mass concentrations of TFD measured during animal exposures.

Initial Range Finding TFD Concentration-Response Studies

Body Weight Changes: Animals exposed to air only lost an average of 0.5% of their body weights 24 hr after the exposure, Table 23. In contrast, animals exposed to concentrations of TFD greater than 137 mg/M³ lost from 2% to 5% of their body weight in the 24 hr period after the exposures. Over all, the body weight reductions in animals exposed to 137 mg/M³ -177 mg/M³ TFD were similar with no firm evidence of an exposure concentration-response relationship for the body weight parameter.

TIME POST EXPOSURE	EXPOSURE TREATMENT						
	AIR	TFD 127 mg/M ³	TFD 137 mg/M ³	TFD 147 mg/M ³	TFD 157 mg/M ³	TFD 167 mg/M ³	TFD 177 mg/M ³
24 HR	-1	-3	-8*	-6*	-9*	-12*	-11*

Table 23. Mean body weight change (gm) upon sacrifice after exposure to air or various concentrations of TFD. (*) denotes significant difference from air control values ($p \leq 0.05$). Each exposure group consisted of 5 - 10 rats.

Lung Gravimetric Changes: Concentration-response relationships of LWW and RCLDW values measured 24 hr after exposure to various concentrations of TFD are illustrated in Figures 26 and 27, respectively. Significant increases in both LWW and RCLDW occurred as of 24 hr after exposure to TFD concentrations above 127 mg/M³. The steepness of the concentration-response curve for TFD-induced increases in LWW and RCLDW was greatest over a concentration range of 127 mg/M³ to 147 mg/M³ TFD. At higher mass concentrations of TFD, LWW and RCLDW appeared to plateau. Approximately 30% of the animals exposed to 167 mg/M³ and approximately 50% of the animals exposed to 177 mg/M³ died within 24 hr after the TFD exposure. Accordingly, the data shown in Figures 26 and 27 were obtained from surviving animals.

Lung Histopathology: No histological abnormalities were observed in the lungs of rats exposed to air only (data not shown).

127 mg TFD/M³

Significant increases in the distribution, severity, and intensity of edema fluid were observed in the lungs 24 hr after exposure to 127 mg/M³ TFD, Table 24. The presence of fibrin at this time, however, was scant. While abnormal numbers of PMN were occasionally observed, an abnormal occurrence of these inflammatory cells could not be statistically verified. On the other hand, the distribution, severity, and intensity of AM were all significantly increased above air control values. No evidence of Type II cell hyperplasia or perivascular congestion was observed (data not shown).

137 mg TFD/M³

The distribution, severity and intensity of lung edema was significantly increased 24 hr after exposure to 137 mg/M³ TFD, Table 24, when compared to values measured on air control animals. At this exposure concentration, fibrin accumulations were minimally observable. While accumulations of PMN were greater in animals exposed to 137 mg/M³ TFD compared to animals exposed to 127 mg/M³ TFD, these elevations were not statistically elevated above control air values. The distribution, severity and intensity of AM were all significantly increased above air control values. No evidence of Type II cell hyperplasia or perivascular congestion was observed (data not shown).

147 mg TFD/M³

Edema fluid accumulation was significantly elevated above control values approximating the accumulations seen at the lower exposure concentrations. However, significant elevations in the distribution, severity and intensity of fibrin accumulations and the presence of PMN were observed 24 hr after exposure to 147 mg/M³ TFD compared to air control values, Table 24. Significant accumulations of AM were also observed 24 hr after exposure to this TFD concentration. Again, no evidence of Type II cell hyperplasia or perivascular congestion was noted in these lungs (data not shown).

157 mg TFD/M³

Twenty-four hr after exposure to this concentration of TFD, the distributions, severities, and intensities

LUNG WET WEIGHT
24 HR POST TFD EXPOSURE

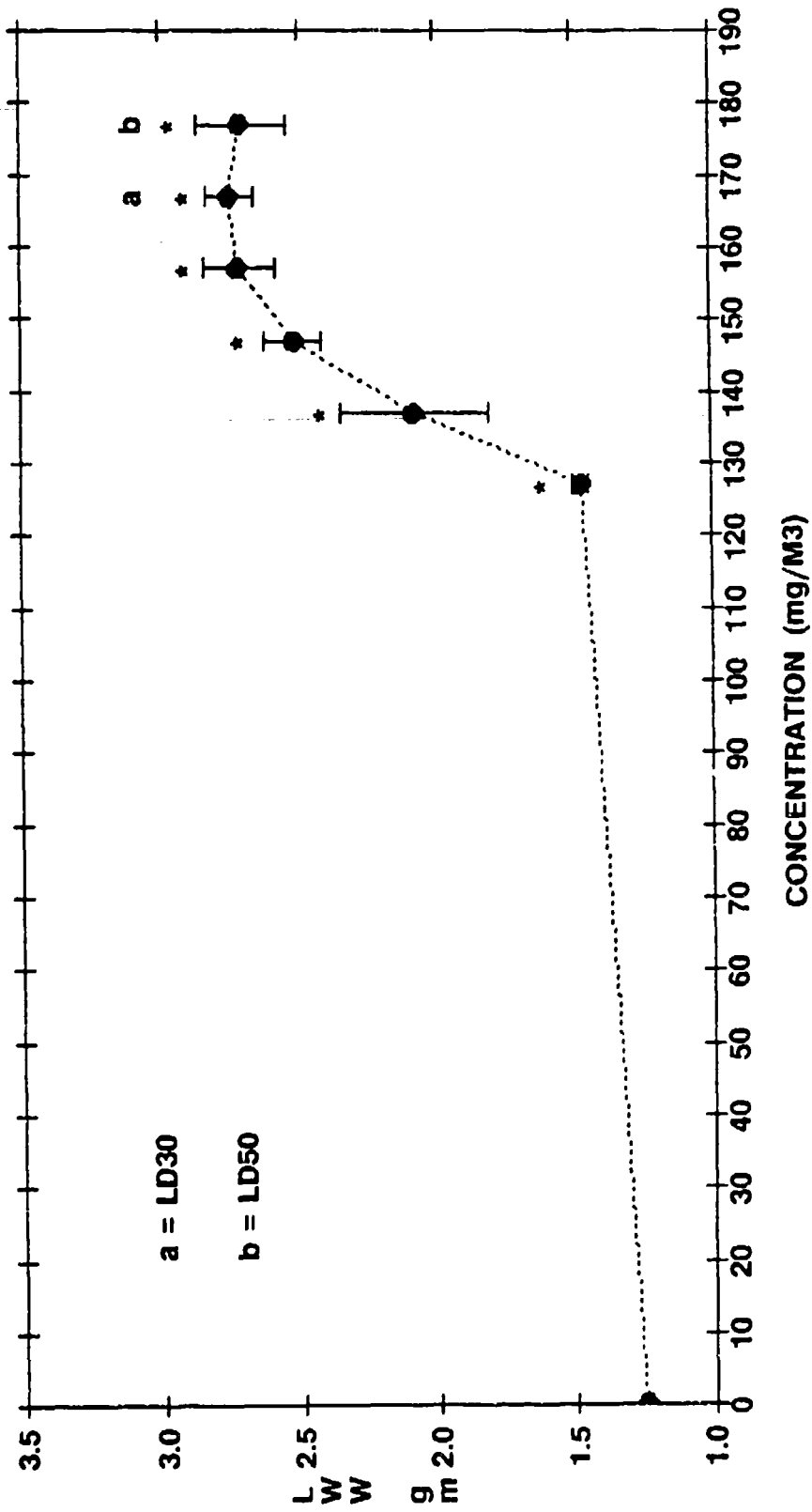

Figure 26. Lung wet weight (LWW) values of animals exposed to air or various concentrations of TFD for a 10 min duration. Each point represents the mean and SEM of 6 to 10 animals. (*) indicate significant increases compared to values measured on animals exposed to air only, (p ≤ 0.05).

**RIGHT CRANIAL LOBE DRY WEIGHT
24 HR POST TFD EXPOSURE**

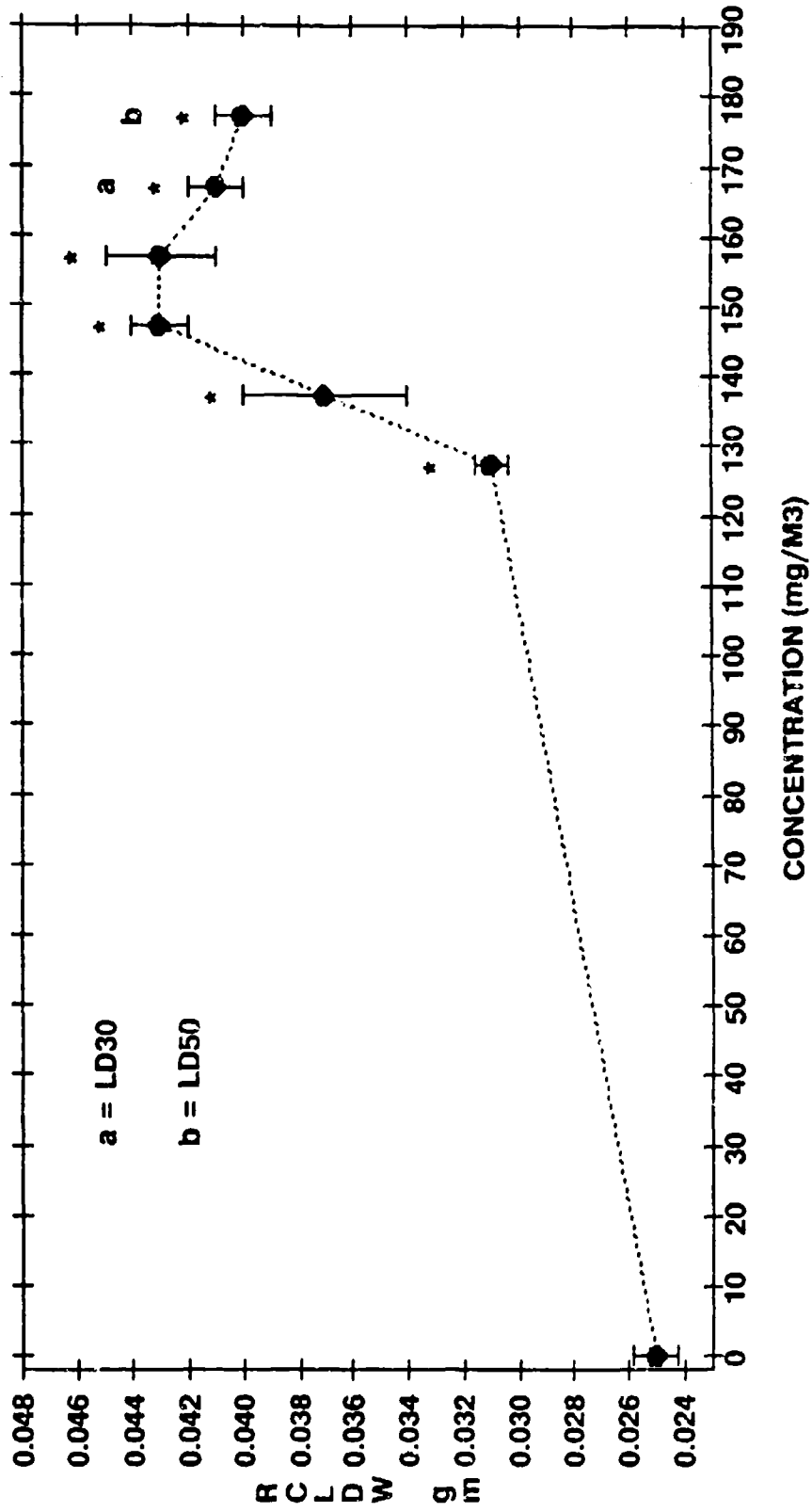

Figure 27. Right cranial lobe dry weight (RCLDW) values of animals exposed to air or various concentrations of TFD for a 10 minute duration. Each point represents the mean and SEM of 6 to 10 animals. (*) indicate significant increases compared to values measured on animals exposed to air only, (p ≤ 0.05).

Nominal Exposure Concentration mg/M ³	<i>Distribution</i>	<i>Severity</i>	<i>Intensity</i>
	Edema Fluid		
127	2.3 ± 0.3*	2.7 ± 0.2*	1.7 ± 0.2*
137	2.0 ± 0.4*	2.3 ± 0.5*	2.0 ± 0.5*
147	2.2 ± 0.2*	2.8 ± 0.2*	2.3 ± 0.2*
157	2.3 ± 0.2*	2.7 ± 0.2*	2.8 ± 0.2*
167	2.3 ± 0.3*	2.8 ± 0.2*	2.9 ± 0.1*
177	2.6 ± 0.3*	2.8 ± 0.2*	2.4 ± 0.2*
	Fibrin		
127	0.3 ± 0.3	0.3 ± 0.3	0.2 ± 0.2
137	0.8 ± 0.5	0.8 ± 0.5	0.7 ± 0.4
147	1.8 ± 0.4*	2.5 ± 0.5*	1.7 ± 0.3*
157	2.5 ± 0.2*	2.5 ± 0.2*	1.6 ± 0.2*
167	3.0 ± 0.3*	3.0 ± 0.2*	1.9 ± 0.1*
177	3.2 ± 0.2*	2.6 ± 0.2*	2.0 ± 0.0*
	Polymorphonuclear Leukocytes		
127	0.3 ± 0.3	0.3 ± 0.3	0.3 ± 0.3
137	1.5 ± 0.7	1.3 ± 0.6	1.2 ± 0.5
147	2.3 ± 0.2*	2.7 ± 0.2*	1.8 ± 0.2*
157	2.2 ± 0.2*	2.2 ± 0.2*	1.5 ± 0.2*
167	2.3 ± 0.5*	1.8 ± 0.4*	1.3 ± 0.3*
177	2.0 ± 0.5*	2.0 ± 0.5*	1.2 ± 0.4*
	Macrophages		
127	3.0 ± 0.0*	2.6 ± 0.2*	2.0 ± 0.0*
137	2.7 ± 0.2*	2.3 ± 0.3*	1.8 ± 0.2*
147	2.5 ± 0.2*	3.0 ± 0.0*	2.0 ± 0.0*
157	3.0 ± 0.0*	2.7 ± 0.2*	2.0 ± 0.0*
167	3.3 ± 0.1*	2.6 ± 0.1*	2.0 ± 0.0*
177	3.2 ± 0.2*	2.8 ± 0.2*	2.0 ± 0.0*

Table 24. Histopathologic evaluation of the dose response of the lung after exposure to various nominal concentrations of TFD. (*) denotes significant difference from air exposed values, $p \leq 0.05$.

of the indices for edema fluid, fibrin, PMN, and AM were all significantly increased above air exposed control values, Table 24. No evidence of Type II cell hyperplasia or perivascular congestion was observed.

167 and 177 mg TFD/M³

As with the 157 mg/M³ TFD exposure concentration, exposure to these higher concentrations also resulted in significant increases in the distributions, severities and intensities of edema fluid, fibrin, PMN, and AM. The main difference between the histopathologic profiles observed with the highest TFD concentrations studied and the lower 157 mg/M³ TFD concentration was the appearance of somewhat more fibrin in the former conditions. As with the lower TFD concentrations, no evidence of a Type II cell hyperplasia or perivascular congestion was observed (data not shown).

137 mg/M³ TFD-Kinetic Response Studies

Body Weight Changes: Initial body weight losses of approximately 2% to 3% occurred within the first 8 hr after exposure to air as well as to 137 mg/M³ TFD, Table 25. Weight losses were recovered by 24 hr in animals exposed to air only whereas body weights continued to be diminished (~2%) in those animals exposed to TFD. The depression of body weight continued to occur up to the 48 hr (~5%) post-exposure sacrifice time.

TIME POST EXPOSURE	EXPOSURE TREATMENT	
	AIR	TFD 137 mg/M ³
0 HR		-1.8 ± 0.3
1 HR	-3.3 ± 0.8	-3.7 ± 0.7
2 HR		-3.3 ± 0.8
4 HR	-4.8 ± 0.3	-5.3 ± 0.8
5 HR		-4.0 ± 0.5
8 HR	-8.6 ± 1.9	-4.8 ± 0.3
24 HR	-1.5 ± 1.1	-5.8 ± 0.9*
48 HR	4.3 ± 1.5	-11.3 ± 4.4*

Table 25. Mean body weight change (gm) upon sacrifice after exposure to air or nominal 137 mg/M³ TFD exposures. (*) denotes significant difference from air control values (p≤0.05). Each exposure group consisted of 5 - 10 rats.

Lung Gravimetric Changes: The LWW and RCLDW values obtained at various times after exposure to 137 mg/M³ TFD are summarized in Figures 28 and 29, respectively. No differences in LWW or RCLDW were detected between any post-exposure sacrifice time when animals were exposed to clean filtered air only. As well, no significant increases in LWW or RCLDW were detected immediately after or 1 or 2 hr after exposure to 137 mg/M³ TFD. However, slight but statistically significant increases in LWW on the order of ~11% were measured at the 4 hr post-exposure time point. RCLDW values, on the other hand, were not significantly elevated above air control values at this time. As of 5 hr post-exposure to 137 mg/M³ TFD, elevations in LWW and RCLDW were both comparably increased ~17% and ~15% respectively. This gradual trend in increasing LWW and RCLDW continued so that by the 8 hr post-exposure time point LWW and RCLDW were ~29% and ~27% above control values, respectively. As of 24 hr after TFD exposure, the LWW values were ~106% and the RCLDW values were ~61% above control values. Over the 4 hr- 24 hr post-exposure interval, the rate of increase in LWW appeared to be relatively constant. Similarly, the rate of increase in RCLDW appeared to be relatively constant over the post-exposure time interval of 5 hr-24 hr. As of 48 hr after TFD exposure, the LWW values were found to be closely similar to those obtained at the 24 hr post-exposure time point, i.e., 48 hr: ~118% increase, 24 hr: ~106% increase. Unlike the LWW, RCLDW values continued to further increase after the 24 hr time point so that by 48 hr after exposure to TFD the RCLDW was ~112% above values measured on animals exposed to air only.

Lung Histopathology: Histopathologic scores for the indices of lung injury obtained in the 137 mg TFD/M³ exposure-kinetic response study are summarized in Tables 26-30. No significant abnormalities were observed until 8 hr after exposure when the distributions, severities, and intensities of edema fluid, Table 26, and AM, Table 29, were increased. As of the 24 hr post-exposure time, the distribution, severity, and intensity values for edema fluid and AM were generally higher than at the 8 hr time point. Additionally, both fibrin, Table 27, and PMN, Table 28, became significant components of the injurious response profile at the 24 hr post-exposure sacrifice time. While the edema fluid, PMN, and AM responses persisted and in many instances further progressed as of the 48 hr post-exposure time point, fibrin was no longer a detectable feature. No significant evidence of a Type II cell hyperplasia, Table 30, was observed at any of the post-exposure study times, although a relatively low level of Type II cell hyperplasia was observed in some of the lung sections. No evidence of perivascular congestion was observed at any of the post exposure sacrifice times at this concentration of TFD, (data not shown).

LUNG WET WEIGHT INCREASE
AFTER ACUTE EXPOSURE TO 137 mg/M TFD

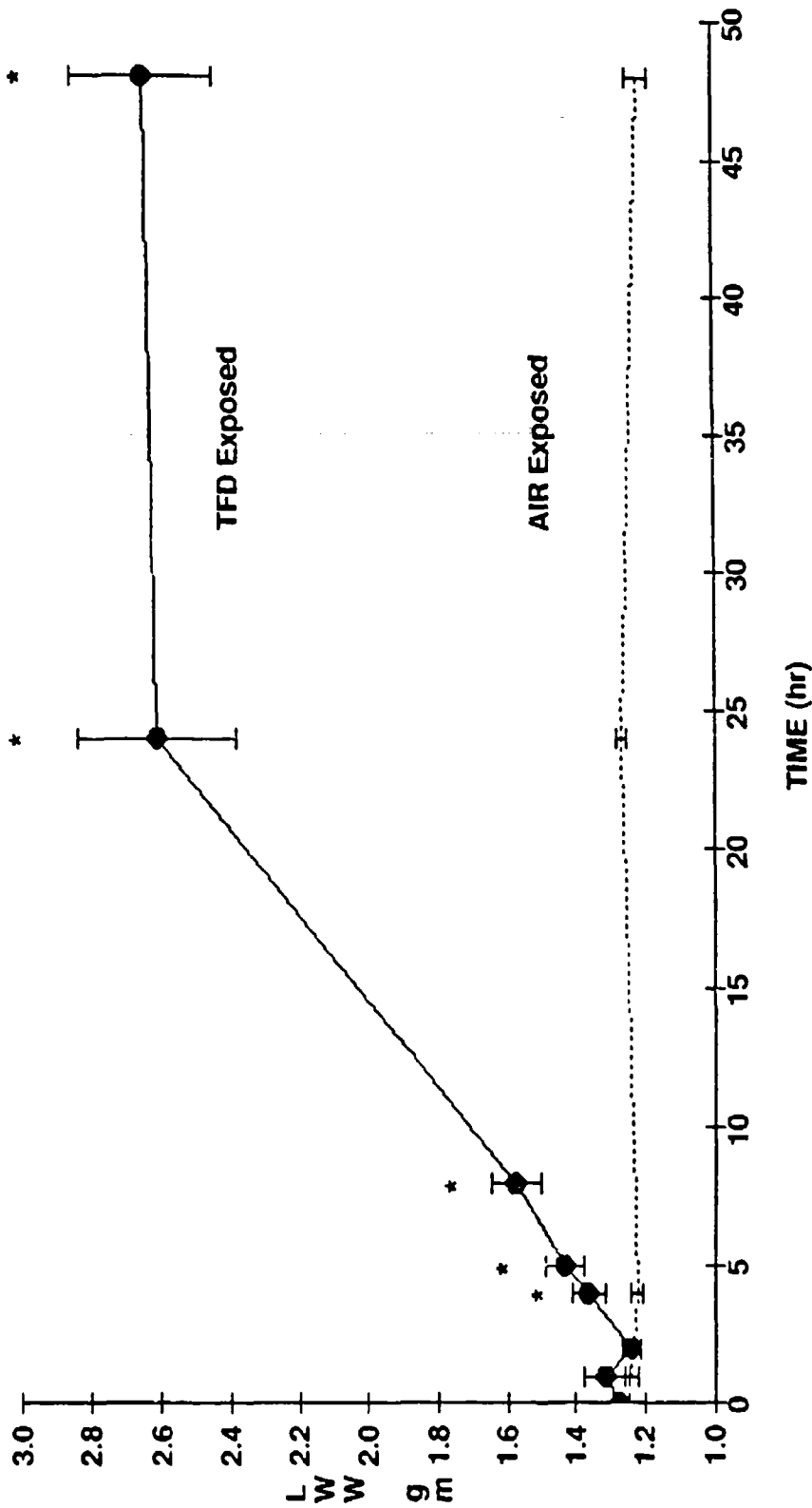

Figure 28. Kinetics of development of pulmonary edema as represented by increases in lung wet weight (LWW) values measured at various times after exposure to nominal 137 mg/M³ TFD exposures. Each point represents the mean and SEM of N = 5 to 10 rats. (*) indicates significant differences compared to values measured on air exposed animals, (p ≤ 0.05).

**RIGHT CRANIAL LOBE DRY WEIGHT INCREASE
AFTER ACUTE EXPOSURE TO 137 mg/M TFD**

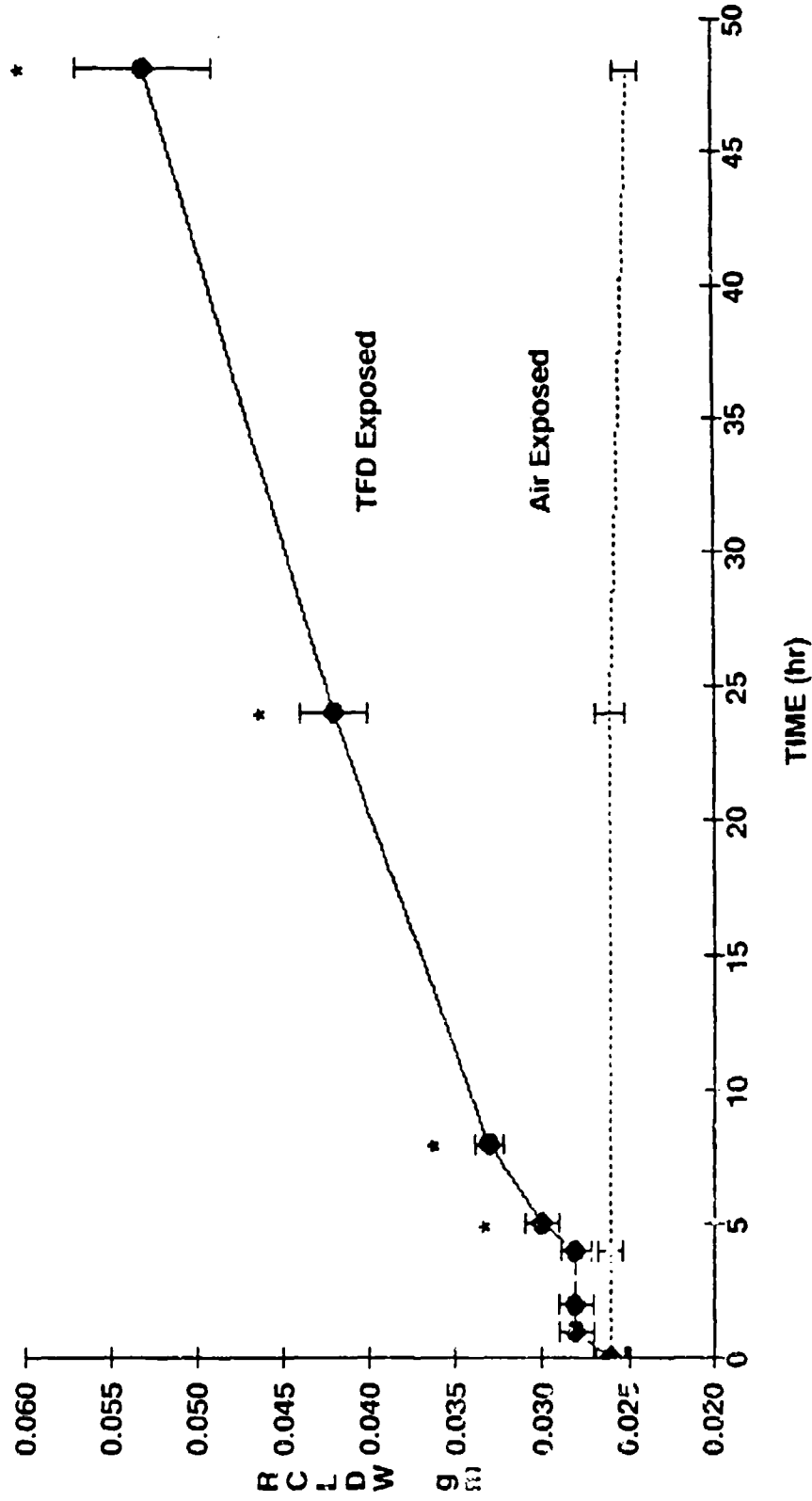

Figure 29. Kinetics of development of pulmonary edema as represented by increases in right cranial lobe dry weight (RCLDW) values measured at various times after exposure to nominal 137 mg/M³ TFD exposures. Each point represents the mean and SEM of N = 5 to 10 rats. (*) indicates significant differences compared to values measured on air exposed animals, (p ≤ 0.05)

137 mg/M ³ TFD Post Exposure Time	Distribution	Severity	Intensity
Edema Fluid			
0 Hr	0	0	0
1 Hr	0.3 ± 0.3	0.7 ± 0.7	0.7 ± 0.7
2 Hr	0	0	0
4 Hr	0.5 ± 0.3	0.7 ± 0.4	0.7 ± 0.4
5 Hr	0.8 ± 0.6	0.8 ± 0.5	0.6 ± 0.4
8 Hr	2.0 ± 0.3*	2.2 ± 0.2*	2.2 ± 0.2*
24 Hr	2.7 ± 0.2*	2.6 ± 0.2*	2.6 ± 0.2*
48 Hr	3.1 ± 0.4*	2.8 ± 0.4*	2.2 ± 0.3*

Table 26. Histopathologic scores of the accumulation of edema fluid from the lungs of animals at designated times after nominal 137 mg/M³ TFD exposures (see text for histopathologic scoring details). (*) Indicates significant difference between TFD exposed and clean air exposed controls, (p ≤ 0.05).

137 mg/M³ TFD	Distribution	Severity	Intensity
Post Exposure Time	Fibrin		
0 Hr	0	0	0
1 Hr	0	0	0
2 Hr	0	0	0
4 Hr	0	0	0
5 Hr	0.8 ± 0.5	0.8 ± 0.5	0.6 ± 0.4
8 Hr	0.7 ± 0.4	0.7 ± 0.4	0.3 ± 0.2
24 Hr	1.7 ± 0.4*	1.9 ± 0.4*	1.2 ± 0.3*
48 Hr	0	0	0

Table 27. Histopathologic scores of the accumulation of fibrin from the lungs of animals at designated times after nominal 137 mg/M³ TFD exposures (see text for histopathologic scoring details). (*) Indicates significant difference between TFD exposed and clean air exposed controls. (p ≤ 0.05).

<u>137 mg/M³ TFD</u>	<i>Distribution</i>	<i>Severity</i>	<i>Intensity</i>
Post Exposure Time	Polymorphonuclear Leukocytes		
0 Hr	0	0	0
1 Hr	0	0	0
2 Hr	0	0	0
4 Hr	0	0	0
5 Hr	0	0	0
8 Hr	0	0	0
24 Hr	2.2 ± 0.4*	2.0 ± 0.3*	1.5 ± 0.2*
48 Hr	3.0 ± 0.2*	2.3 ± 0.2*	1.9 ± 0.1*

Table 28. Histopathologic scores of the occurrence of polymorphonuclear leukocytes in the lungs of animals at designated times after nominal 137 mg/M³ TFD exposure (see text for histopathologic scoring details). (*) indicates significant difference between TFD exposed and clean air exposed controls, (p ≤ 0.05).

<u>137 mg/M³ TFD</u>	Distribution	Severity	Intensity
Post Exposure Time	Macrophages		
0 Hr	0	0	0
1 Hr	0	0	0
2 Hr	0	0	0
4 Hr	1.0 ± 0.5	0.8 ± 0.4	0.5 ± 0.2
5 Hr	1.2 ± 0.5	1.0 ± 0.5	1.0 ± 0.5
8 Hr	2.2 ± 0.2*	2.0 ± 0.0*	1.8 ± 0.2*
24 Hr	2.8 ± 0.2*	2.2 ± 0.1*	1.9 ± 0.1*
48 Hr	3.6 ± 0.2*	3.2 ± 0.2*	2.3 ± 0.2*

Table 29. Histopathologic scores of the occurrence of macrophages in the lungs of animals at designated times after nominal 137 mg/M³ TFD exposure (see text for histopathologic scoring details). (*) indicates significant difference between TFD exposed and clean air exposed controls, (p ≤ 0.05).

<u>137 mg/M³ TFD</u>	<u>Distribution</u>	<u>Severity</u>	<u>Intensity</u>
<u>Post Exposure Time</u>	Type II Cell Hyperplasia		
1 Hr	0	0	0
2 Hr	0	0	0
4 Hr	0	0	0
5 Hr	0	0	0
8 Hr	0	0	0
24 Hr	0	0	0
48 Hr	0.6 ± 0.4	0.6 ± 0.4	0.4 ± 0.3

Table 30. Histopathologic scores of the occurrence of Type II Cell Hyperplasia in the lungs of animals at designated times after nominal 137 mg/M³ TFD exposure (see text for histopathologic scoring details). (*) indicates significant difference between TFD exposed and clean air exposed controls, (p ≤ 0.05).

TFD Exercise Studies

Lung Gravimetric Measurements: As previously indicated, a mass concentration of TFD of 137 mg/M³ was selected for the exercise potential and work performance capacity studies. The data illustrated in Figures 30 and 31 summarize the post-exposure LWW and RCLDW values obtained from animals exposed to 137 mg/M³ TFD for 10 min and rested or exercised at various times after exposure. No significant differences in the resulting LWW or RCLDW occurred if animals were exercised immediately after exposure and sacrificed 1 hr after exposure compared LWW and RCLDW values obtained on animals exposed to TFD and rested after exposure. LWW and RCLDW values obtained from rats exposed to 137 mg/M³ TFD followed by a 1 hr exercise bout and sacrificed 2 hr post-exposure were significantly elevated (~39% for LWW and ~18% for RCLDW) compared to TFD exposed and rested values obtained at this time point. Markedly greater increases in LWW (~109%) and RCLDW (~30%) were obtained when animals were exercised 4 hr post TFD exposure and then sacrificed 5 hr post-exposure relative to corresponding TFD exposed and rested values. LWW and RCLDW values from this exercise group remained significantly elevated for the 24 hr time point, i.e., ~60% increases in LWW and ~23% increases in RCLDW, and while somewhat reduced, remained significantly elevated, to at least the 48 hr time point, i.e. ~17% increases in LWW and ~13% increases in RCLDW values beyond the LWW and RCLDW values obtained with rats that were exposed to the TFD, rested, and sacrificed 48 hr after the exposure. When animals were exercised 23 hr post 137 mg/M³ PFIB exposure, significant increases of LWW (~30%) and RCLDW (~25%) were obtained 1 hr later at a 24 hr post-exposure sacrifice time. Exercise performed 47 hr after TFD exposure had no potentiating effect on LWW or RCLDW values measured at a 48 hr post-exposure time point. An approximate "window of susceptibility" to the potentiating effects of exercise is illustrated in Figures 30 and 31. It is likely that the window remains "open" for some time beyond the identified 23 hr post-exposure time point.

Rats were exposed to TFD 4 hr after the exposure, again exercised 47 hr after exposure, and then sacrificed 1 hr later in order to determine if the initial exercise bout would extend the "window of susceptibility." As shown in figures 30 and 31, the second exercise bout did not cause further increases in the LWW and RCLDW values beyond those increases produced by a single 4 hr post exposure exercise bout only. Thus, exercise performed early during the "window of susceptibility" did not extend the "window of susceptibility" to the potentiating effects of exercise within the limits of the post-exposure time points examined.

Lung Histopathology: Exercise performed immediately after TFD exposure resulted in no detectable histopathologic abnormalities in the lungs of rats that were sacrificed 1 hr post-exposure, Tables 31-35. When rats were exercised 1 hr after 137 mg/M³ TFD exposure and sacrificed 1 hr later, significant increases in the distribution, severity and intensity of fibrin, Table 32, and AM accumulations, Table 34, were observed compared to TFD exposed and rested rats that were sacrificed 2 hr post-exposure. When rats were exercised 4 hr after TFD exposure and then sacrificed 1 hr later, significant increases in

EFFECTS OF POST EXPOSURE EXERCISE
AFTER EXPOSURE TO 137 mg/M TFD

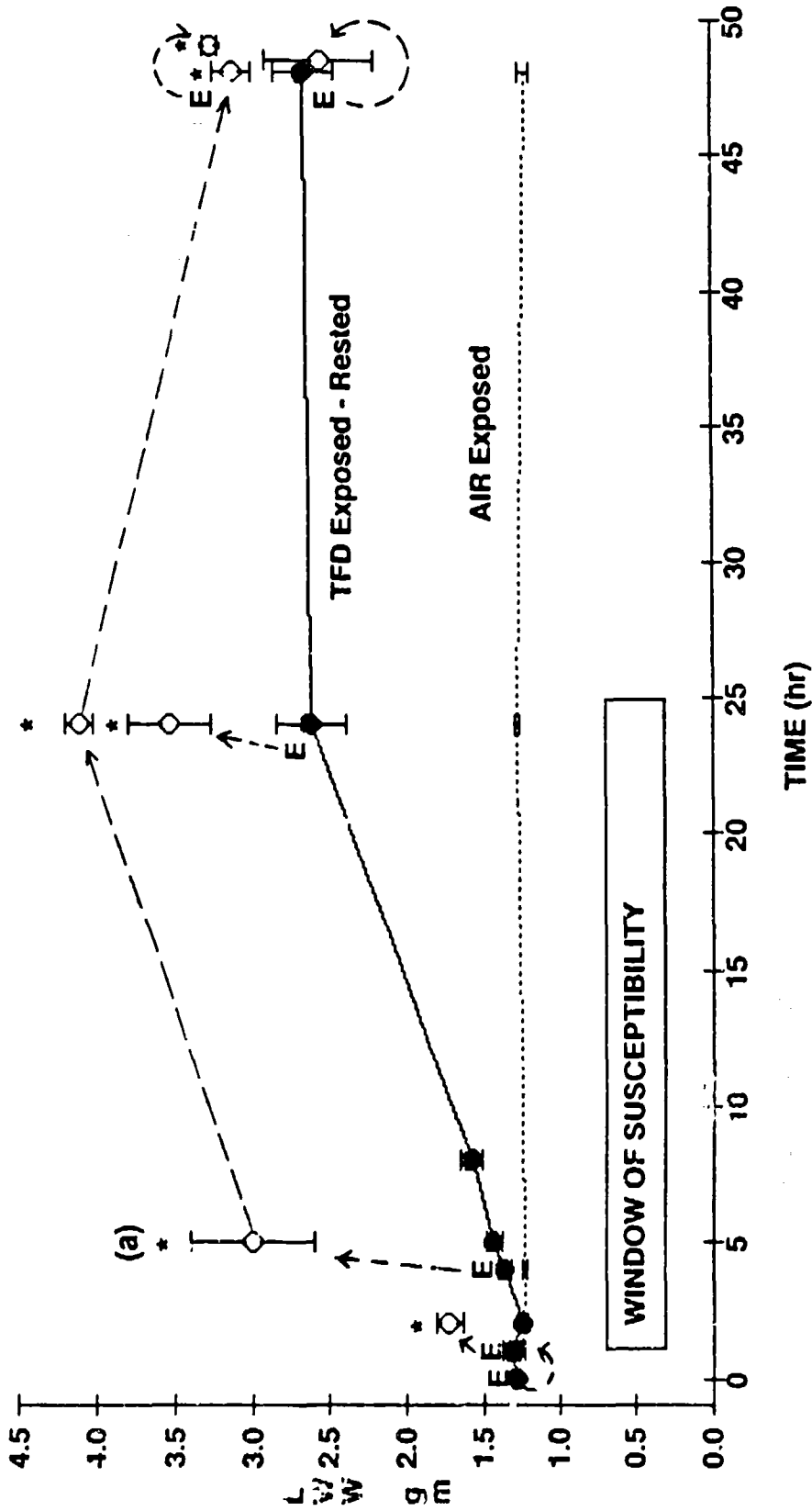

Figure 30. Lung wet weight (LWW) responses after exercise at various times after exposure to nominal 137 mg/M³ TFD. (---) = Air exposed and rested values. (—) = TFD exposed and rested values. (E) = Time of exercise bout. (—) = Resulting LWW value after exercise. (*) denotes significant increases in LWW above the TFD exposed and rested condition at that particular sacrifice time point, (P ≤ 0.05). (a) = approximately 25% of the animals died within 24 hrs after the 1 hr exercise bout.

**EFFECTS OF POST EXPOSURE EXERCISE
AFTER EXPOSURE TO 137 mg/M TFD**

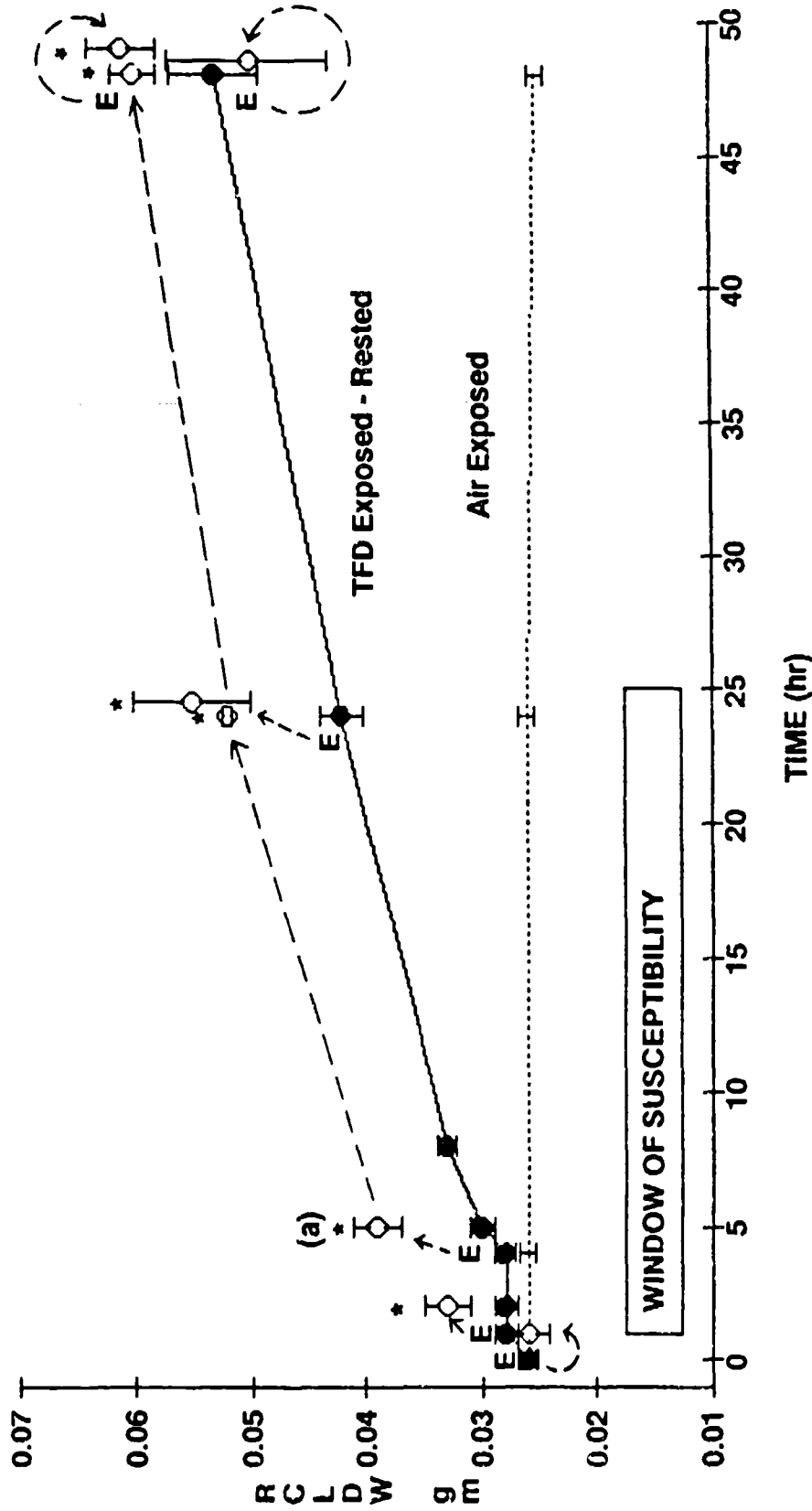

Figure 31. Right cranial lobe dry weight (RCLDW) responses after exercise at various times after exposure to nominal 137 mg/M³ TFD. (---) = Air exposed and rested values. (—) = TFD exposed and rested values. (E) = Time of exercise bout. (---) = Resulting RCLDW value after exercise. (*) denotes significant increases in RCLDW above the TFD exposed and rested condition at that particular sacrifice time point, (P ≤ 0.05). (a) = approximately 25% of the animals died within 24 hrs after the 4 hr exercise bout.

137 mg/M³ TFD		Disirbution	Severity	Intensity
Post Exposure Sacrifice Time	Post Exposure Exercise Time			
		Edema Fluid		
1 Hr	0 Hr	0.7 ± 0.5	1.0 ± 0.6	1.5 ± 0.9
2 Hr	1 Hr	1.0 ± 0.6	1.0 ± 0.6	1.0 ± 0.6
5 Hr	4 Hr	2.0 ± 0.0	2.0 ± 0.0	2.2 ± 0.3*
24 Hr	4 Hr	1.8 ± 0.6	2.3 ± 0.8	2.3 ± 0.8
24 Hr	23 Hr	2.8 ± 0.3	2.8 ± 0.4	3.0 ± 0.0
48 Hr	47 Hr	2.8 ± 0.2	3.2 ± 0.4	2.0 ± 0.3

Table 31. Histopathologic scores for the accumulation of edema fluid from the lungs of animals exercised at designated times after nominal 137 mg/M³ TFD exposure, (see text for histopathologic scoring details). (*) indicates significant difference between post TFD exposure exercise groups and TFD exposed and rested control groups, (p ≤ 0.05).

137 mg/M ³ TFD		Distribution	Severity	Intensity
Post Exposure Sacrifice Time	Post Exposure Exercise Time	Fibrin		
1 Hr	0 Hr	0	0	0
2 Hr	1 Hr	3.3 ± 0.5*	2.3 ± 0.3*	1.5 ± 0.3*
5 Hr	4 Hr	2.5 ± 0.3*	2.0 ± 0.4	1.8 ± 0.3
24 Hr	4 Hr	1.5 ± 0.9	1.3 ± 0.8	1.0 ± 0.6
24 Hr	23 Hr	2.5 ± 0.3	3.0 ± 0.0	2.0 ± 0.0
48 Hr	47 Hr	0	0	0

Table 32. Histopathologic scores of the accumulation of fibrin from the lungs of animals exercised at designated times after nominal 137 mg/M³ TFD exposures, (see text for histopathologic scoring details). (*) indicates significant difference between post TFD exposure exercise groups and TFD exposed and rested control groups, (p ≤ 0.05).

137 mg/M³ TFD		Distribution	Severity	Intensity
Post Exposure Sacrifice Time	Post Exposure Exercise Time			
1 Hr	0 Hr	0	0	0
2 Hr	1 Hr	0	0	0
5 Hr	4 Hr	0	0	0
24 Hr	4 Hr	2.3 ± 0.3	2.5 ± 0.3	1.8 ± 0.3
24 Hr	23 Hr	2.5 ± 0.3	2.8 ± 0.3	2.0 ± 0.0
48 Hr	47 Hr	2.8 ± 0.2	2.8 ± 0.4	1.8 ± 0.2

Table 33. Histopathologic scores for the occurrence of polymorphonuclear leukocytes in the lungs of animals exercised at designated times after nominal 137 mg/M³ TFD exposures, (see text for histopathologic scoring details). (*) indicates significant difference between post TFD exposure exercise groups and TFD exposed and rested groups, (p ≤ 0.05).

<u>137 mg/M³ TFD</u>		Distribution	Severity	Intensity
Post Exposure Sacrifice Time	Post Exposure Exercise Time	Macrophages		
1 Hr	0 Hr	0.5 ± 0.5	0.5 ± 0.5	0.3 ± 0.3
2 Hr	1 Hr	3.3 ± 0.5*	2.5 ± 0.3*	1.5 ± 0.3*
5 Hr	4 Hr	2.0 ± 0.0	2.0 ± 0.0	1.5 ± 0.3
24 Hr	4 Hr	3.0 ± 0.0	2.8 ± 0.3	2.0 ± 0.0
24 Hr	23 Hr	3.0 ± 0.0	2.5 ± 0.3	2.0 ± 0.0
48 Hr	47 Hr	2.8 ± 0.2	3.2 ± 0.4	2.6 ± 0.4

Table 34. Histopathologic scores from the occurrence of macrophages in the lungs of animals exercised at designated times after nominal 137 mg/M³ TFD exposure, (see text for histopathologic scoring details). (*) indicates significance difference between post TFD exposure exercise groups and TFD exposed and rested groups, (p ≤ 0.05).

<u>137 mg/M³ TFD</u>		Distribution	Severity	Intensity
Post Exposure Sacrifice Time	Post Exposure Exercise Time	Type II Cell Hyperplasia		
1 Hr	0 Hr	0	0	0
2 Hr	1 Hr	0	0	0
5 Hr	4 Hr	0	0	0
24 Hr	4 Hr	0	0	0
24 Hr	23 Hr	0	0	0
48 Hr	47 Hr	1.4 ± 0.6	1.2 ± 0.5	1.2 ± 0.5

Table 35. Histopathologic scores from the occurrence of Type II Cell Hyperplasia in the lungs of animals exercised at designated times after nominal 137 mg/M³ TFD exposure. (see text for histopathologic scoring details). (*) indicates significance difference between post TFD exposure exercise groups and TFD exposed and rested groups, (p ≤ 0.05).

the distribution of fibrin as well as the amount of edema fluid in the alveoli were observed relative to fibrin distribution values and edema intensity levels present in the lungs of TFD exposed and rested animals, Table 31 and 32. No other significant increases above corresponding control values were observed for any of the histopathologic parameters. Exercise 23 hr and 47 hr after TFD exposure did not significantly alter the histopathologic profile of lung injury in rats that were sacrificed at the 24 or 48 hr post-exposure time points, respectively, compared to resting controls.

Work Performance: Work performance, as indexed by maximum oxygen consumption (VO_{2max}), was significantly reduced ~21% as of 4 hr after exposure to 137 mg/M³ TFD, whereas VO_{2max} values obtained immediately after and 1 hr after TFD exposure were not significantly different from those obtained with air exposed control animals, Table 36.

<u>137 mg/M³ TFD</u>	
Post Exposure Exercise Time	Maximum Oxygen Consumption (Percent change from pre-exposure values)
0 HR	-4.4 ± 5.8
1 Hr	-11.6 ± 5.9
4 Hr	-21.4 ± 6.2*
23 Hr	-60.0 ± 4.8*
47 Hr	-45.6 ± 11.1*
4 & 47 Hr	-21.4 ± 6.2*, -63.3 ± 0.8*

Table 36. Percent change in the maximum oxygen consumption (VO_{2max}) values compared to the mean of several pre values. Each animal serves as its own control. (*) indicates significant difference of the mean of post-exposure values compared to the mean of pre-exposure values ($p \leq 0.05$).

Maximal reductions in VO_{2max} (~60% reduction) occurred 23 hr after TFD exposure. A significant reduction in VO_{2max} persisted up until the last 47 hr post-exposure time, but, as of then, the reduction in work performance capacity was not as marked as that observed at the 23 hr post-exposure time point, Table 36.

The TFD-associated reductions in VO_{2max} appeared to be proportionately related to the degree of pulmonary edema present at the time the "ramp" exercise bout was performed, Figure 32. It is possible

RELATIONSHIP OF LUNG WET WEIGHT AND DEGRADATION OF WORK PERFORMANCE
AFTER EXPOSURE TO 137 mg/M³ TFD FOR 10 MIN

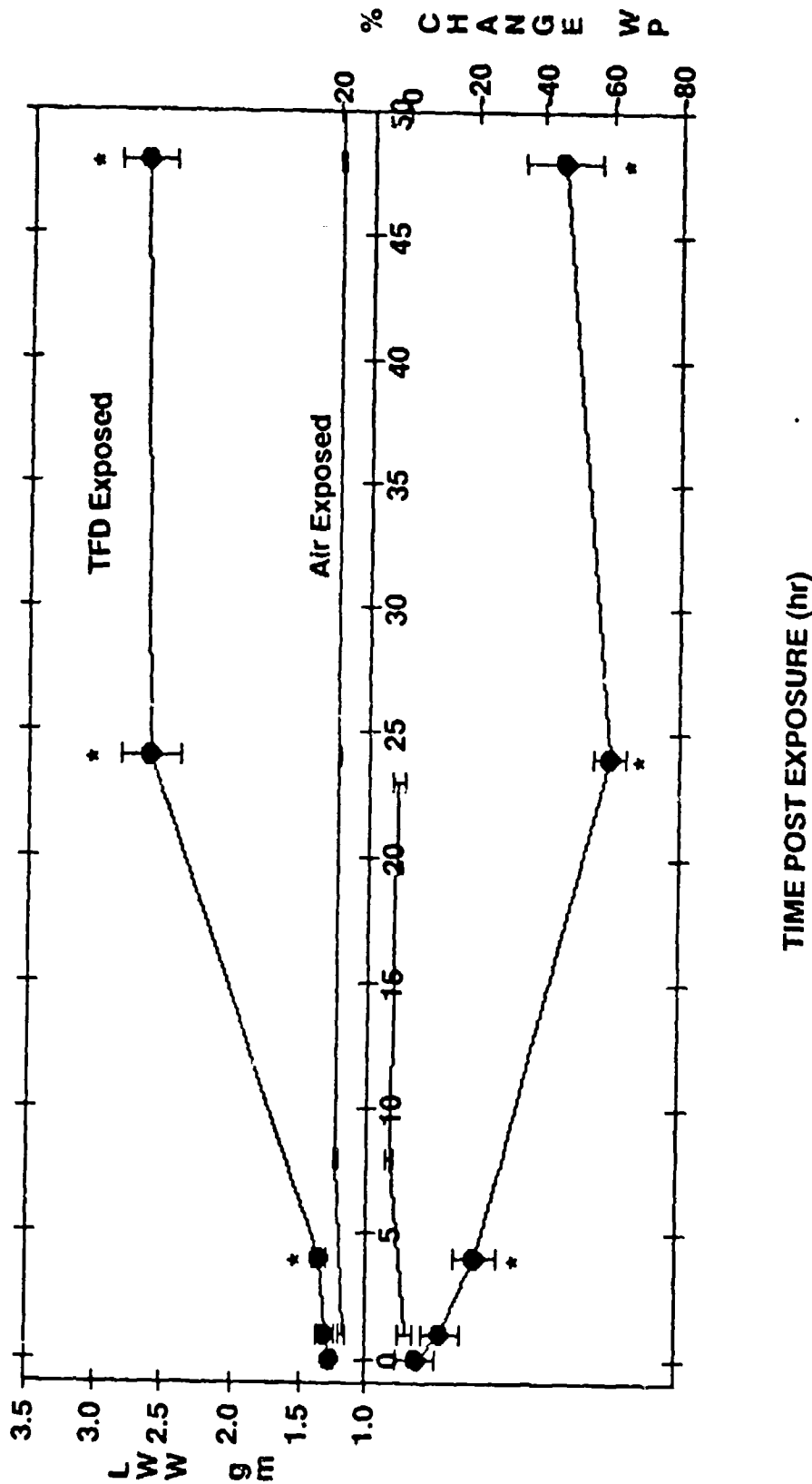

Figure 32. Post exposure degradation of work performance (% change VO_{2max}) of rats exposed to either air x 10 min or 137 mg/M³ TFD for 10 min. Also presented are the lung wet weight (LWW) responses of rats exposed to 137 mg/M³ TFD for 10 min and rested after exposure. (*) indicate significant difference from post air exposed values. Each point represents the mean and SEM of 5 to 6 animals.

**% CHANGE VO₂ max
IN RELATION TO LWV AFTER EXPOSURE TO TFD**

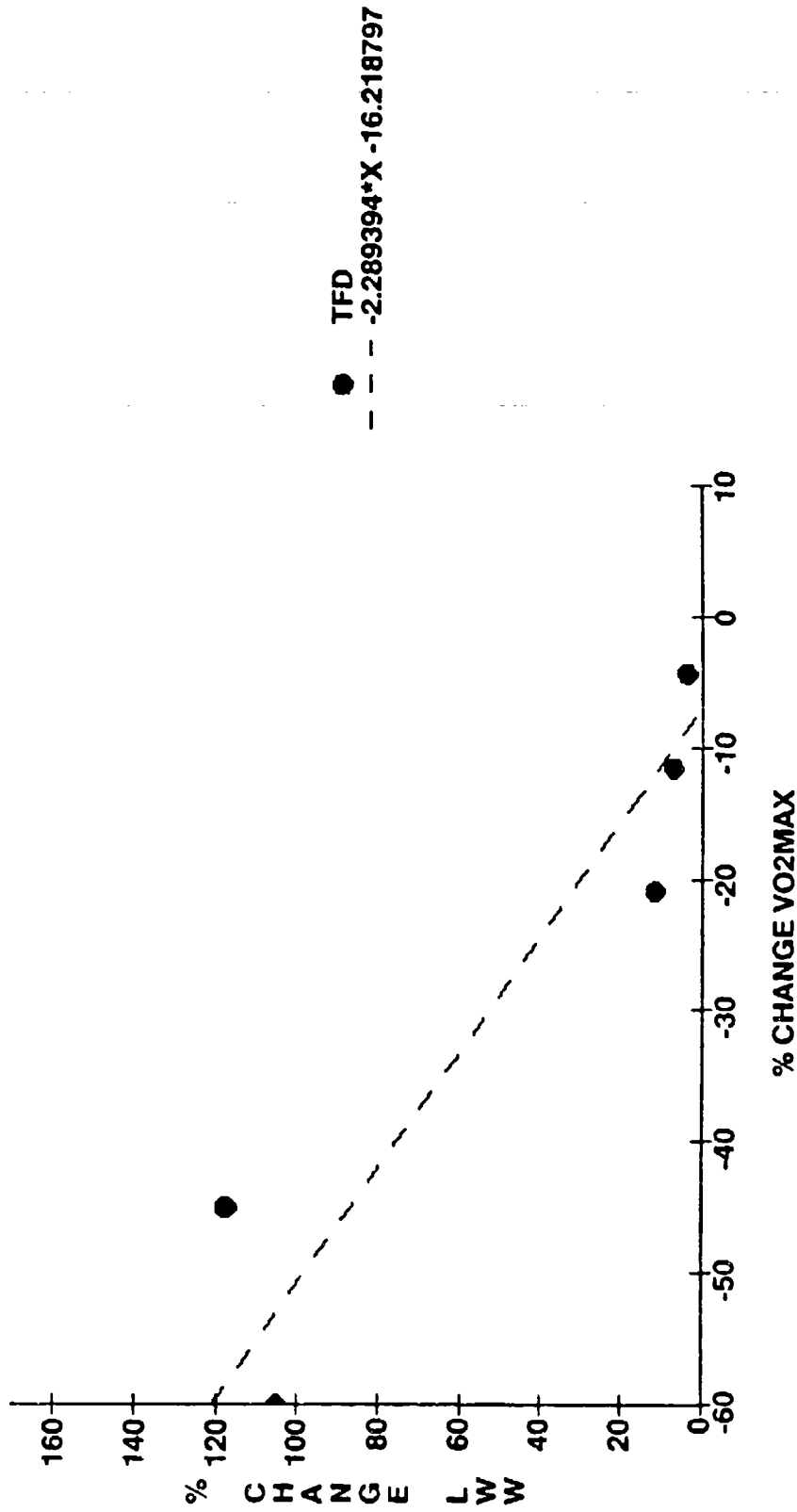

Figure 33. Post exposure degradation of work performance (% change VO_{2max}) as a function of lung wet weight (LWW). Each point represents the mean percent change of maximum oxygen consumption (VO_{2max}) measured at various times post 137 mg/M³ TFD and plotting these values against corresponding mean values measured on separate TFD exposed but rested animals sacrificed at the same sacrifice time.

that the reductions in $VO_{2\max}$ following TFD exposure linearly scales with the extent of pre-existing pulmonary edema, as indexed by the LWW parameter, Figure 33.

Summary Statements

Generalized Conclusions from the PFIB Investigations

- **The magnitude or severity of resulting lung injury increases with increasing concentration of inhaled PFIB.**
- **Relatively small differences in PFIB mass concentration, i.e., ~10%, can substantially impact on the severity of resulting lung injury.**
- **The kinetics of onset of PFIB-induced lung injury become more rapid with increasing exposure mass concentration. For lower mass concentrations of PFIB, this results in a delay or a latency period prior to the development of detectable lung injury, whereas lung injury can be detected essentially immediately after exposure to high mass concentrations. Over all, the post-exposure latency period appears to be inversely proportional to exposure mass concentration.**
- **Post-exposure exercise performed during the latency period does not potentiate the expression of resulting lung injury.**
- **An approximate "window of susceptibility" to the potentiating effects of exercise following a 10 min exposure to 100 mg/M³ PFIB occurs between 8 and 18 hr after exposure. It is likely that the "window of susceptibility" actually "closes" sometime after the 12 hr post-exposure time point. Given the observation that exercise does not exert a potentiating effect when performed during a post-PFIB exposure latency period, it remains possible that the "window of susceptibility" to the potentiating effects of exercise will vary as a function of exposure mass concentration of PFIB.**
- **Exercise performed early during the "window of susceptibility" does not appear to further extend the "window of susceptibility".**
- **No significant reductions in work performance capacity occur when exercise is performed during the post-PFIB exposure latency period, whereas substantial reductions in work performance capacity occur when pre-existing pulmonary edema is present.**

- Post-PFIB exposure reductions in work performance capacity appear to be directly proportional to the extent of pulmonary edema present at the time exercise is performed.
- With the possible exception of alveolar macrophages and interstitial lung fibroblasts, virtually every cell in the alveolar region appears to be affected by the toxic effects of PFIB. Additional, ultrastructural evidence has also indicated that epithelial cells along the conducting airways are also sensitive to the toxic effects of PFIB.

Generalized Conclusions from the TFD Investigations

- The magnitude or severity of resulting lung injury increases with increasing mass concentration of inhaled TFD.
- Like PFIB, a very steep concentration-response curve exists over a TFD concentration range of 127 mg/M³ to 147 mg/M³ TFD where relatively small differences in inhaled TFD mass concentration can substantially impact on the severity of resulting lung injury. However, at concentrations above 147 mg/M³ TFD, the steepness of the concentration-response curve shows evidence of being attenuated.
- An apparent ~3-4 hr latency period during which no evidence of lung injury was detected by the endpoints employed was observed following the inhalation of TFD at a mass concentration of 137 mg/M³. Thereafter, the development of pulmonary edema progressively developed at an apparent constant rate over a subsequent period of at least 20 hr.
- Exercise performed as early as 1 hr post 137 mg/M³ TFD exposure, during the post-TFD exposure latency period, can significantly potentiate the expression of TFD-induced lung injury.
- An approximate "window of susceptibility" to the potentiating effects of exercise following a 10 min exposure to 137 mg/M³ TFD occurs between 1 and 23 hr after exposure. The actual closure of the "window of susceptibility" most likely actually occurs sometime between 23 and 47 hr after exposure.
- Exercise performed early within the "window of susceptibility" does not appear to further

extend the "window of susceptibility".

- **Significant reductions in work performance capacity occur as early as 4 hr after exposure to 137 mg/M³ TFD exposure. Significant reductions in work performance capacity occur when pre-existing pulmonary injury is present.**
- **Post-TFD exposure reductions in work performance capacity appear to be directly proportional to the extent of pulmonary edema present at the time exercise is performed.**

References

- Astrand, P., and Rodahl, K.: *Textbook of Work Physiology*. McGraw Hill, New York, NY, 1986.
- Gurley, L.R., Spall, W.D., Valdez, J.G., London, J.E., Dethloff, L.A., and Lehnert, B.E.: An HPLC procedure for the analysis of proteins in lung lavage fluid. *Analytical Biochemistry* 172:465-478, 1988.
- Gurley, L.R., London, J.E., Dethloff, L.A., Stavert, D.M. and Lehnert, B.E.: Analysis of proteins in bronchoalveolar lavage fluids during pulmonary edema resulting from nitrogen dioxide and cadmium exposure. In: *Techniques in Protein Chemistry*, Academic Press, San Diego, CA, 1989.
- Gurley, L.R., London, J.E., Valdez, Y.E., Lehnert, N.M., Stavert, D.M., and Lehnert, B.E.: Free cell response and lavage fluid biochemical changes following acute exposures to perfluoroisobutylene. 29th Annual meeting of the Society of Toxicology, Miami Beach, FL, February 12-16, 1990. *The Toxicologist* 10:A811, 1990.
- Lehnert, B.E., and Stavert, D.M.: Ultrastructural changes in the lung following exposure to perfluoroisobutylene (PFIB) and potentiation of PFIB-induced lung injury by exercise. 1990 U.S. Army Chemical Research, Development and Engineering Center scientific Conference on Chemical Defense Research, Aberdeen Proving Ground, MD, November 13-16, 1990.
- Lehnert, B.E., Valdez, Y.E., Sebring, R.J., Lehnert, N.M., Saunders, G.C., and Steinkamp, J.A.: Airway Intra-luminal macrophages: Evidence of origin and comparisons to alveolar macrophages. *Am. J. Respir. Cell Mol. Biol.* 3:377-391, 1990.
- Mautz, W.J., McClure, T.R., Reischl, F., Phalen, R.F., and Crocker, T.T: Enhancement of ozone-induced lung injury by exercise. *J. Toxicol Environ. Health.* 16:841-854, 1985.
- Sebring, R., Stavert, D.M., and Lehnert, B.E.: Electron microscopic study of perfluoroisobutylene-induced acute lung injury. 29th Annual meeting of the Society of Toxicology, Miami Beach, FL, February 12-16, 1990. *The Toxicologist* 10:A809, 1990.
- Snedecor, G.W., and Cochran, W.G.: The comparison of two samples. In: *Statistical Methods*. 6th Ed. The Iowa State University Press, Ames, Iowa, pp. 99-199, 1969a.
- Snedecor, G.W., and Cochran, W.G.: Shortcut and non-parametric methods. In: *Statistical Methods*. 6th Ed. The Iowa State University Press, Ames, Iowa, pp.120-134, 1969b.
- Stavert, D.M., Archuleta, D.C., Holland, L.M., and Lehnert, B.E.: Exposure to 35 ppm NO₂ for 25 days does not produce emphysema or cause a progression of pre-existing emphysema in the rat lung. *J. Toxicol. Environ. Health* 17:249-267, 1986.
- Stavert, D.M., Archuleta, D., Wood, G., Behr, M.J., and Lehnert, B.E.: Acute inhalation of perfluoroisobutylene: Concentration-response kinetics. 29th Annual Meeting of the Society of Toxicology, Miami Beach, FL, February 12-16, 1990. *The Toxicologist* 10:A809, 1990.
- Stavert, D.M., and Lehnert, B.E.: Work performance evaluation using the exercising rat model. Proceedings of the Sixth Medical Chemical Defense Bioscience Review. John Hopkins University, Baltimore, MD, August 4-6, 1987.

Stavert, D.M., and Lehnert, B.E.: Potentiation of expression of nitrogen dioxide induced lung injury by post exposure exercise. *Environ. Res.* 48:87-99, 1989.

Stavert, D.M., and Lehnert, B.E.: Nitric oxide and nitrogen dioxide as inducers of acute pulmonary injury when inhaled at relatively high concentrations for brief periods. *Inhal. Toxicol.* 2:53-67, 1990.

Stavert, D.M., Wilson, J.S., Archuleta, D.C., and Lehnert, B.E.: The effects of nitrogen dioxide inhalation are potentiated by post-exposure exercise. American Thoracic Society Annual Meeting, May 10-13, 1987, New Orleans, LA. *Am. Rev. Resp. Dis.* 135:a281, 1987.

Tillery, S.I., and Lehnert, B.E.: Age-body weight relationships to lung growth in the F344 rat as indexed by lung weight measurements. *Lab. Anim.* 20:189-194, 1986.