

2

**Heavy Division Synchronization:
Impact of the AirLand Battle-Future Concept**

**A Monograph
by
Major James E. Zanol
Armor**

DTIC FILE COPY



**DTIC
ELECTE
APRO 5 1991
S B D**

**School of Advanced Military Studies
United States Army Command and General Staff College
Fort Leavenworth, Kansas**

First Term AY 90-91

Approved for Public Release; Distribution is Unlimited

REPORT DOCUMENTATION PAGE

Form Approved
OMB No. 0704-0188

1a. REPORT SECURITY CLASSIFICATION UNCLASSIFIED		1b. RESTRICTIVE MARKINGS	
2a. SECURITY CLASSIFICATION AUTHORITY		3. DISTRIBUTION / AVAILABILITY OF REPORT APPROVED FOR PUBLIC RELEASE; DISTRIBUTION UNLIMITED.	
2b. DECLASSIFICATION / DOWNGRADING SCHEDULE		4. PERFORMING ORGANIZATION REPORT NUMBER(S)	
4. PERFORMING ORGANIZATION REPORT NUMBER(S)		5. MONITORING ORGANIZATION REPORT NUMBER(S)	
6a. NAME OF PERFORMING ORGANIZATION SCHOOL OF ADVANCED MILITARY STUDIES	6b. OFFICE SYMBOL (If applicable) ATZL-SWV	7a. NAME OF MONITORING ORGANIZATION	
6c. ADDRESS (City, State, and ZIP Code) FORT LEAVENWORTH, KANSAS 66027-6900		7b. ADDRESS (City, State, and ZIP Code)	
8a. NAME OF FUNDING / SPONSORING ORGANIZATION	8b. OFFICE SYMBOL (If applicable)	9. PROCUREMENT INSTRUMENT IDENTIFICATION NUMBER	
8c. ADDRESS (City, State, and ZIP Code)		10. SOURCE OF FUNDING NUMBERS	
		PROGRAM ELEMENT NO.	PROJECT NO.
		TASK NO.	WORK UNIT ACCESSION NO.
11. TITLE (Include Security Classification) HEAVY DIVISION SYNCHRONIZATION: IMPACT OF THE AIRLAND BATTLE - FUTURE CONCEPT (U)			
12. PERSONAL AUTHOR(S) MAJOR JAMES E. ZANOL, USA			
13a. TYPE OF REPORT MONOGRAPH	13b. TIME COVERED FROM _____ TO _____	14. DATE OF REPORT (Year, Month, Day) 91/01/02	15. PAGE COUNT 65
16. SUPPLEMENTARY NOTATION			
17. COSATI CODES		18. SUBJECT TERMS (Continue on reverse if necessary and identify by block number)	
FIELD	GROUP	SYNCHRONIZATION	
		AIRLAND BATTLE	
		AIRLAND BATTLE - FUTURE	
		DIVISION OPERATIONS	
		DOCTRINE	
19. ABSTRACT (Continue on reverse if necessary and identify by block number) This monograph concludes that the essential tasks needing synchronization by the division do not change. However, nonlinear battle will indeed require exquisite synchronization. An essential skill that must improve is the commander's ability to visualize the battle, develop his intent, and express it to his staff. Leader development must focus on making decisions with accurate but incomplete information. Commander and staff must know doctrine and the interrelationships of battlefield systems. The expanded time and space dimensions makes mastery of those elements essential for success.			
20. DISTRIBUTION / AVAILABILITY OF ABSTRACT <input checked="" type="checkbox"/> UNCLASSIFIED/UNLIMITED <input type="checkbox"/> SAME AS RPT. <input type="checkbox"/> DTIC USERS		21. ABSTRACT SECURITY CLASSIFICATION UNCLASSIFIED	
22a. NAME OF RESPONSIBLE INDIVIDUAL		22b. TELEPHONE (Include Area Code)	22c. OFFICE SYMBOL

SCHOOL OF ADVANCED MILITARY STUDIES

MONOGRAPH APPROVAL

Major James E. Zanol

Title of Monograph: Heavy Division Synchronization:
Impact of the AirLand Battle -
Future Concept

Approved by:

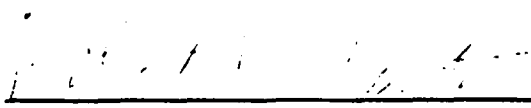

Dr. Robert M. Epstein, Ph.d. Monograph Director



COL G.F. Atcheson, MA Director, School of
Advanced Military
Studies

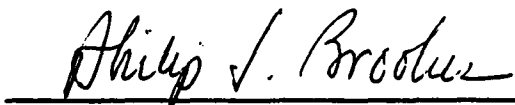

Philip J. Brookes, Ph.D. Director, Graduate
Degree Program

Accepted this 28th day of January 1991

ABSTRACT

HEAVY DIVISION SYNCHRONIZATION: IMPACT OF THE AIRLAND-FUTURE CONCEPT by MAJ James E. Zanol, USA, 65 pages.

This monograph looks at how the AirLand Battle-Future concept changes heavy division synchronization in the attack. To find these effects, three subordinate questions provided supporting information. First, how well do divisions synchronize using current doctrine? Second, what implications for synchronization come from the AirLand Battle-Future concept? Finally, how can the heavy division achieve exquisite synchronization? The criteria for this study were the elements of synchronization: time, space, and purpose.

A theory of war review of time, space, and purpose showed the importance of the criteria to warfighting concepts. The works of Clausewitz, Jomini, and Sun Tzu formed the theoretical base for this review. Also, analysis of the CRUSADER battle in North Africa 1941 used the criteria. The conditions and conduct of this battle provided useful lessons for AirLand Battle-Future synchronization. Results of the Battle Command Training Program show that current divisions have trouble effectively synchronizing combat power. The methodology of this study included a short planning process using AirLand Battle-Future concepts for a division attack.

The conclusions of this monograph are that the essential tasks needing synchronization by the division do not change. However, nonlinear battle will indeed require exquisite synchronization. An essential skill that must improve is the commander's ability to visualize the battle, develop his intent, and express it to his staff. Leader development must focus on making decisions with accurate but incomplete information. Commanders and staffs must know doctrine and the interrelationships of battlefield systems. The expanded time and space dimensions makes mastery of those elements essential for success.

Accession For	
NTIS GRA&I	<input checked="" type="checkbox"/>
DTIC TAB	<input type="checkbox"/>
Unannounced	<input type="checkbox"/>
Justification	
By _____	
Distribution/	
Availability Codes	
Dist	Avail and/or Special
A-1	

Table of Contents

	Page
Part I Introduction	1
Part II CRUSADER	7
Part III Contemporary Division Operations	14
Part IV <u>AirLand Battle-Future</u>	19
Part V <u>AirLand Battle-Future</u> Attack	27
Part VI Conclusions	36
Endnotes	40
Bibliography	46
Appendix A Definitions	51
Appendix B Maps	53
Appendix C ALB-F Force Structure	57
Appendix D Order Material	60

I. Introduction

AirLand Battle doctrine, published in FM 100-5 Operations in 1982, introduced synchronization as one of four basic tenets. Since then, Army units have had trouble planning and executing synchronized plans.¹ However, as the Army develops future doctrine, it plans to keep the four tenets of AirLand Battle doctrine. The new concept, AirLand Battle-Future, takes synchronization to a higher level. At this new level, synchronization on the future battlefield must be exquisite.² Synchronization becomes more important in the future, smaller Army.³ A smaller combat force must mass all available combat power to win its battles. Massing combat power is the essence of synchronization. Therefore, we must know how new warfighting concepts warfightchange our current understanding of synchronization.

This monograph explores how the AirLand Battle-Future concept changes heavy division synchronization in the attack. To find these effects, three subordinate questions provide supporting information. First, how well do divisions synchronize operations using current doctrine? Second, what implications for synchronization come from the AirLand Battle-Future concept? Finally, how can the heavy division achieve exquisite synchronization? The answers to these questions can have a significant impact in coming years.

To answer these questions, this monograph begins by setting the framework for analysis, including the criteria. Next, we will analyze a World War II battle to determine lessons on synchronization from history. Moving to the present, we will review the current division's ability to synchronize combat power using present doctrine. This is followed by an introduction of AirLand Battle-Future concepts, an examination of an attack order, and finally insights on the AirLand Battle-Future concepts' impact on synchronization. To begin this study, certain assumptions were necessary.

The tactical situation used to examine AirLand Battle-Future concepts was built on the following assumptions. Future friendly and enemy equipment capabilities remain roughly equal to current systems. Also, the nature of the war is mid-intensity conventional combat and deployment and theater development of both combatants are complete. Further, U.S. forces have air parity and can gain local air superiority. The enemy force employs Soviet doctrine which includes echelonment. In addition to these assumptions, limits to the scope of this monograph help focus the analysis.

This inquiry on the AirLand Battle-Future concept covers specific battlefield activities. It uses five of seven battlefield operating systems for analysis. These systems classify functions and activities that occur on

the battlefield. The five systems used are: command and control, fire support, intelligence, combat service support, fire and maneuver.

A further limitation of this study is no use of force on force wargame simulations. However, this study does use relative combat power calculations based on doctrinal estimate procedures. This study examines one combat cycle described in AirLand Battle-Future. Within these limits, the criteria provide the core concepts of analysis.

The criteria come from the definition of synchronization in FM 100-5. "Synchronization is the arrangement of battlefield activities in time, space, and purpose to produce maximum relative combat power at the decisive point."⁴ Time, space, purpose serve as the criteria for this study. Time is a critical element of synchronization. Any activity on the battlefield takes time to complete. Time is a resource common to friendly and enemy forces, and it constrains both forces. Movement occurs in time and space, highlighting the close relationship between these elements.⁵

Space is the physical environment in which combatant forces operate. Like time, space is a finite resource. Activities occurring in space require time to

complete.⁶ Friendly and enemy forces use the width and depth of the battlefield to achieve a synchronized combat action. However, a single, overriding goal directs the use of space and time.

The most important element of synchronization is purpose. Purpose is the desired result of the commander. He expresses the result in his concept of the operation and intent.⁷ Purpose defines why activities must occur in time and space to accomplish the mission. Synchronization of activities in time and space to achieve a desired purpose, therefore, begins in the mind of the commander.⁸

A more complete understanding of the criteria can show the value of synchronization in current and future warfighting concepts. Therefore, a review of how the theory of war views time, space, and purpose is useful.

Theory of war helps explain why time, space, and purpose are important. A review of three important theorists reveals their thoughts on these parts of synchronization. Preeminent in theory of war are the works of Carl von Clausewitz and Henri Jomini. Also, the ancient Chinese soldier of fortune, Sun Tzu, provides valuable insights on warfare. All of these theorists spoke to the importance of time.

Carl von Clausewitz, Prussian general and scholar of the Napoleonic era, recognized the importance of time. In his instructions to the Crown Prince of

Prussia, Clausewitz warned against wasting time. Any time wasted benefits the enemy.⁷ Clausewitz also taught his pupils to commit troops to battle at the right time. The commander does not piecemeal or immediately commit all his forces. He must commit force in decisive mass at the critical moment.¹⁰

Baron Henri Jomini, French general and contemporary of Clausewitz, also spoke of the importance of time in battle. Part of Jomini's basic principle of war includes:

To so arrange that these masses shall not only be thrown upon the decisive point, but that they shall engage at the proper times and with ample energy.¹¹

Further, Jomini recognized the problem in tactics is to ensure simultaneous use of the forces available. These forces must combine to develop the power to ensure victory.¹² While Clausewitz and Jomini reflect the Napoleonic era, ancient theorists also valued time.

Sun Tzu lived in China around 450 B.C.. His writings reflect his experience as a general for many of the warring states in that country. Sun Tzu knew time is important to momentum in battle. So, the attacker insures that he precisely regulates his force.¹³ These theorists also recognize the close relationship between time and space.

Clausewitz wrote that space is important only in relation to the enemy. He felt that the size of the army's front is not important.¹⁴ It is more important

to select one point of the enemy's position and attack it with superior force.¹⁵

One of Jomini's important contributions to the theory of war is his description of parts of the battlefield. His definitions of decisive points, lines of operations, points of maneuver, and many other terms set the relationship of space to operations.¹⁶ Further, Jomini saw that a series of rapid and continuous marches multiplies the effect of an army. This quick movement over space can neutralize a large part of the enemy force.¹⁷

Sun Tzu also recognized the value of using space to an advantage. He expressed this belief in one of his cryptic lines, "Move when it is advantageous and create changes in the situation by dispersal and concentration of forces."¹⁸ Time and space are tools the commander used to achieve his purpose. Accordingly, purpose focuses the use of these tools.

Purpose for Clausewitz was very simple. All action focuses on the engagement and destruction of the enemy. The commander must "pursue one great decisive aim with force and determination."¹⁹ The commander must use his entire force with utmost energy. Any moderation results in failing to achieve the goal.²⁰

Jomini's basic principle of war sums up his idea of purpose and use of time and space:

On the battlefield, to throw the mass of the forces upon the decisive point, or upon that portion of the hostile line which it is of the first importance to overthrow.²¹

Finally, Sun Tzu said that the commander who unites his forces in purpose will gain victory.²² These writers speak directly to the close relationship between time, space, and purpose. Purpose gives meaning to the use of time and space. Understanding what is possible, through the use of time and space, the commander then arranges tactical actions to achieve his purpose. Simultaneous and sequential activities (time) occurring across the battlefield (space) create tactical effects (purpose) that lead to the final goal (purpose). Clausewitz, Jomini, and Sun Tzu clearly realized the importance of time, space, and purpose in war.

This review of theory reinforces the importance of the criteria to the study of warfighting concepts. Using the criteria, history can also provide many useful lessons for examining AirLand Battle-Future.

II. CRUSADER

Between 18 and 26 November 1941, German and British forces fought a fierce battle under unique conditions. Erwin Rommel commanded the Panzer Groupe Afrika. Opposing him was the British Eighth Army. This army and its commander, Cunningham, entered combat for the first time in North Africa. Like the Panzer Groupe Afrika,

the Eighth Army consisted of armored, motorized, and infantry units. The conditions of the CRUSADER battle mirror those expected on a nonlinear battlefield. An analysis of this battle provides important lessons for synchronized action in the future. (Maps App B)

The British offensive, codenamed CRUSADER, began on 18 November 1941. Aided by air superiority and bad weather that grounded the Axis air forces, the British succeeded in gaining tactical surprise.

The British plan sent one thrust by the XIII Corps along the coast to Tobruk. A second column by XXX Corps swung west to find and destroy German armored units. Failing to take advantage of massed armored forces, the British assigned the two corps roughly equal armored power.

Intent on his Tobruk operation, Rommel would not recognize the growing threat in his east. Warned by his intelligence officer and General Cruewell, commander of the Afrika Korps, Rommel still did not respond. Instead, he delivered a terse statement, "we must keep our nerves."²³

By the evening of 19 November, leading British units had reached their assigned objectives. The 7th Armored Brigade had seized Sidi Rezegh. However, the armored force of XXX Corps had widely dispersed. This piecemealing of armored units was dangerous since Rommel's armor remained out of contact.

Finally, on 19 November Rommel allowed Cruewell to deal with the British armor. This force prepared to move out on the morning of 20 November.

General Cruewell and the 15th Panzer Division headed for Sidi Aziz while one battle group of the 21st Panzer Division attacked toward Sidi Omar. This was the area based on reconnaissance reports, where Cruewell expected to find the British main effort. However, 15 Panzer Division reached Sidi Rezegh without contact. The 21 Panzer Division had a running battle with the British 4th Armored Brigade. Cruewell then correctly assessed that the British main effort was at Sidi Rezegh. He reunited the Afrika Korps and prepared to move to Sidi Rezegh.

Action on 21 November convinced Rommel that the British activity was in fact a major offensive. That morning British forces in Tobruk tried to breakout to join with the 7th Armored Brigade at Sidi Rezegh. Rommel and the 90th Light Division moved to this area to develop the situation.

What happened at Sidi Rezegh was unique. The German 90th Light Division occupied the ridge north of Sidi Rezegh. On the airfield in the village were elements of 7th Armored Brigade. The Afrika Korps approached from the south. Behind the Afrika Korps and to southwest was the remainder of XXX Corps. Allied and Axis forces had layered themselves south of Tobruk. The

Germans won this initial battle at Sidi Rezegh. However, General Cruewell did not see it that way. The night of 21 November, he ordered the withdrawal of the Afrika Korps to the north and east to regroup.

The Germans attacked and seized Sidi Rezegh on 22 November. General Cruewell prepared to finish off XXX Corps the following day. Before Cruewell could receive Rommel's instructions for 23 November, British troops captured his headquarters. Cruewell escaped capture and executed his plan.

Cruewell launched his attack and caught the British unprepared. Rather than turn north to finish off the enemy, Cruewell continued south to join with the Ariete Division. When this combined Axis force turned back toward Sidi Rezegh, the British had recovered and prepared for the German return. After suffering heavy losses, the Germans had decisively beaten XXX Corps. General Cruewell reported to Rommel his victory and intention to complete the destruction of XXX Corps on 24 November. However, Rommel had other ideas.

Rommel intended to take Afrika Korps and "dash for the wire" on the Egyptian frontier. Leaving behind enough force to hold the British, Rommel began his counterstroke on 24 November 1941. This attack allowed XXX Corps and XIII Corps time to recoup their strength. LTC Westphal, Rommel's operations officer, recognized the danger as the British continued to press for Tobruk.

Westphal could not contact Rommel, so he personally ordered Afrika Korps back to stabilize the Tobruk area. By 26 November, Rommel and the Afrika Korps had reunited with the rest of the Panzer Gruppe. The CRUSADER battle raged on for some time, the British eventually winning. The intense, confused battles around Sidi Rezegh epitomize armored combat under nonlinear conditions.

The criteria applied to this battle provide lessons valuable for synchronization. The British XXX Corps failed repeatedly to synchronize its combat power. This failure resulted from losing focus on their purpose. Cunningham's goal for CRUSADER was destruction of Rommel's armor.²⁴ Yet from the very beginning he took actions that detracted from this goal. Cunningham assigned 4th Armored Brigade to XIII Corps for flank protection.²⁵ This naturally reduced the armored concentration of XXX Corps. Further, on 19 November, 22d Armored Brigade stopped to battle the Italians at Bir Gubi. This left only 7th Armored Brigade to seize Sidi Rezegh.²⁶ Thus, the British could not concentrate armored units when the battle they desired was presented. While the Germans kept a better focus on their purpose than the British, they also had problems.

General Cruewell launched his attack on 23 November against remnants of XXX Corps. His initial attack caught the British by surprise. Rather than change his plan to fully complete his victory, Cruewell insisted on

joining with the Ariete Division. This action gave the British time to recover, making Cruewell's victory pyrrhic at best.²⁷ The following day, Rommel also abandoned his purpose.

Following Cruewell's costly victory on 23 November, Rommel ordered Afrika Korps to attack to the east. This was the infamous "dash to the wire." Rommel risked leaving XXX Corps behind to regroup. Rommel believed a maneuver to cut the lines of communication of the Eighth Army would complete his victory. Instead, the British did in fact regroup, and XIII Corps continued to attack for Tobruk. In the end, rather than winning by destroying XXX Corps, Rommel had to withdraw to save his command.²⁸ Losing focus on the purpose of their plans dearly cost both sides. A further result of this problem was the ineffective use of time and space.

The XXX Corps provides most of the examples of poor understanding of time and space. The first example occurred on 20 November. Cruewell, after finding no British in the east, turned back for Sidi Rezegh. He ran into the 4th Armored Brigade. This was the enemy action for which Cunningham had planned. However, he had dispersed his armored brigades.²⁹ Cunningham saw the danger and ordered 22 Armored Brigade from Bir Gubi to march east to help 4th Brigade. Unfortunately,

because of the dispersion of these brigades, the 22nd did not arrive in time. 15th Panzer Division mauled the 4th Armored Brigade.³⁰

22nd Armored Brigade's synchronization efforts did not improve the next day. On 21 November, Cruewell had reunited the Afrika Korps and began to move to Sidi Rezegh. The 22d Brigade mistimed their counterattack, missing the flank of the Afrika Korps. Later that day, Cruewell's two divisions attacked 7th Armored Brigade at Sidi Rezegh.³¹

The British also did not coordinate attacks at Sidi Rezegh. On 21 November, the Afrika Korps conducted coordinated attacks against 7th Armored Brigade. The remainder of XXX Corps launched piecemeal counterattacks that had little effect.³² Failing to consider time and space, the British could not concentrate combat power against the Germans.

Rommel and Cunningham provide a contrast of leadership and its effect on synchronization. Rommel always commanded close to the action. This helped him quickly understand the situation and concentrate his combat power at the decisive point. Cunningham remained at his command post or one of his corps command posts. The effect of time and distance prevented Cunningham from taking timely action.³³ The British commanders failed in all their efforts to concentrate their three armored brigades. Rommel and Cruewell had superior

ability to coordinate their effort. The Afrika Korps always appeared in decisive strength at the place it mattered most.³⁴

Synchronizing combat power in time, space, and purpose proved decisive in North Africa, 1941. Rommel was superior in this skill, permitting him to nearly defeat a numerically stronger enemy. The British won CRUSADER eventually through sheer numbers and Rommel's poor supply situation. Divisions of the U.S. Army still must use time, space, and purpose. AirLand Battle requires synchronized use of combat power. Evidence suggests however that those units struggle with synchronization.

III. Contemporary Division Operations

Contemporary heavy divisions have used AirLand Battle doctrine since 1982. Recognizing that doctrine is always changing, recent publications should reflect current understanding of synchronization.

The division operations manual, FM 71-100 Division Operations, published in 1990, continues to emphasize synchronized operations. Synchronization generates the maximum combat power of the division.³⁵ One quote sums up the essence of the division task, "The division must train as it will ... fight - a combined arms force integrating and synchronizing all combat and CSS assets."³⁶

The division uses mobility to concentrate combat power at the decisive time and place. The division moves and positions maneuver forces on terrain in relation to the enemy to gain positional advantage.³⁷ The maneuver system relies on other operating systems to exploit the division's mobility.

The division commander must have timely intelligence to synchronize his forces. The intelligence system provides the commander information he needs to synchronize combat power. As such, intelligence preparation of the battlefield (IPB) is a critical function.

IPB products, particularly the decision support template, provide the commander a visual representation of the battlefield and the enemy. The decision support template becomes a master execution matrix, correlating time-distance for friendly and enemy forces.³⁸ The intelligence system and IPB help effectively use the division fire support system.

The division's fire support system is a major part of its combat power. The concentrated fire of the division will devastate an enemy force. Fire support synchronization relies on rapid transfer of information among division fire support systems and those of other services.³⁹ Fire support and other systems have limited effectiveness without a significant sustainment effort.

Combat service support is a critical part of the synchronization task for the current division. Ignoring combat service support limits the "lethal reach" of the heavy division. However, the process and product of the command and control system synchronize all other systems.

The commander synchronizes combat power through his command and control system. The command and control system is the tool for changing potential into actual combat power. This system must have flexibility, redundancy, and survivability to synchronize the division's combat and CS/CSS operations.⁴⁰ Until recently, division commanders and staffs had little opportunity for rigorous evaluation of their ability to synchronize combat power.

The Battle Command Training Program (BCTP) is the Army's training and evaluation system for its divisions. This program takes advantage of computer simulations to save costs. BCTP trains division and corps commanders and staff in the tenets and principles of AirLand Battle doctrine.⁴¹ The training program begins with a seminar on team building, staff procedures, and doctrine. The second part of the program is a command post exercise called Warfighter.⁴² The Battle Command Training Program provides evidence into the ability of divisions to synchronize operations.

BCTP Warfighter exercise after action reports do not present a bright picture of division synchronization. These lessons learned contain information on the battlefield operating systems used in this study.

Maneuver occurs in time and space, a fact often overlooked in division synchronization. Time-distance factors are critical to the decision making process.⁴³ Staffs have an inability to provide the commander accurate planning information in time and distance terms. Key to moving combat power to the right time and place is backward planning, something many staffs do not do.⁴⁴ Effective maneuver depends on knowing where and when to move.

The division intelligence effort must be a continuous process. Division staffs have trouble linking the IPB with the concept of the operation. Other weaknesses include incomplete IPB products, poor wargaming, noninvolvement of the commander and G3 in IPB and wargaming.⁴⁵ Knowing where the enemy is located is critical to focusing combat power on him.

BCTP results often show a disconnection between fire and maneuver, fire plans, and desired results. Clearly, the targeting process is misunderstood. Fires often do not support the commander's intent or synchronize with other systems. The connection between

the target, the sensor to find it, and the weapon to attack it is often not clear.⁴⁶ Also, the sustainment system suffers from poor synchronization.

Most combat service support plans react to the situation. Maneuver forces frequently leave behind their combat support and combat service support units. BCTP observer controllers have seen many critical logistic activities not occur in time to sustain the force.⁴⁷ Reconstitution is reactive, poorly planned and coordinated.⁴⁸ The burden of putting these operating systems together in a synchronized plan falls on the division command and staff.

The commander and his staff often do not know doctrine on division operations. Problems in the command and control system include:

Staffs lack the proficiency to apply doctrinal procedures and techniques that help the commander see the battlefield.

Commanders and staffs fail to effectively use doctrinal tools and process that facilitate agility and synchronization.⁴⁹

Use of nonstandard terms, insufficient or inappropriate control measures resulting in poor execution.⁵⁰

The BCTP is revealing the lack of synchronization skill at the division level. Fortunately, the program is making significant improvement in these skills across the Army.

Synchronization is difficult for the Army's heavy divisions using AirLand Battle doctrine. Evidence on how a future division will synchronize plans may come from a review of emerging doctrine.

IV. AirLand Battle-Future

AirLand Battle-Future (ALB-F) represents the evolution of the Army's warfighting doctrine. The 1986 version of AirLand Battle doctrine reflects a European focus.⁵¹ Changes in the strategic context require the Army to review and update its doctrine. The evolving concept in turn leads to updates in doctrine, training, leader development, organization, materiel and programs.⁵²

AirLand Battle-Future recognizes the need for synchronized planning and execution. Early writings and briefing material on the concept called for exquisite synchronization.⁵³ However, current draft documents also use the terms "enhanced" or "highly synchronized."⁵⁴ There is a growing recognition of the importance of synchronization to the nonlinear concept. General Foss, Commander of the Training and Doctrine Command, recently called for closer examination of synchronization.⁵⁵ AirLand Battle-Future is not an unlimited view of the future. Its horizon has limits.

The AirLand Battle-Future concept covers the immediate future of the Army. This concept looks forward five to fifteen years. In that time, the nation

must re-examine its interests. ALB-F recognizes that the Army will always fight in joint or combined environment. Additionally, the Army must meet threats across the spectrum of conflict. Accordingly, the Army must have a global perspective. Our doctrine cannot become focused on one threat in one area of operation.⁵⁶ Taking this perspective, the Army must be prepared to perform many missions.

Responding to national interests, the Army will execute various missions. The authors of AirLand Battle-Future doctrine list ten missions for the Army.⁵⁷ These missions range from contingency to reinforcement operations. As such, this wide variety of operations requires the Army to maintain a unique force structure.

The Army must meet its mission requirements while its force structure becomes smaller.⁵⁸ The armed services must provide the National Command Authority a range of options. The Army can do this with easily tailorable forces. This strategic force must be deployable and lethal containing a mix of heavy, light, and special operating forces. The logistics system must also be as flexible and deployable to sustain the combat forces. While the Army gets smaller, it must take advantage of advanced technology to develop more combat power.

The United States' strength is its technological ability. The AirLand Battle-Future concept makes wide use of advanced technology. Over the next fifteen years the Army must decide, however, on what technology to buy. Intelligence systems, long range indirect fire systems, and enhanced command and control systems have priority. However, the future concept recognizes two limitations. Any technical advance will have little lasting effect. Also, the Army will operate with a mix of old and new systems.⁵⁷ Further, AirLand Battle-Future has other implications. One implication important to maneuver forces is the nonlinear battlefield.

Nonlinear conditions will dominate the future battlefield. Reduced force levels cause these conditions, while the operational environment expands.⁵⁸ As a result, large gaps between forces will be common. These forces must operate in all directions and with high speed.⁵⁹ Therefore, nonlinear conditions demand changes in tactics.

Tactical nonlinearity recognizes the changing conditions of the battlefield and works to exploit them. (The definition of tactical nonlinearity is in Appendix A.) A key point is placement of units. Units occupy dispersed, separated areas. From these areas, units must mass to meet the enemy. Emphasis is on destroying the enemy rather than keeping terrain. A line of

contact does not lock friendly maneuver forces in place. The nonlinear battlefield requires rapid movement to concentrate, fight, and disperse. A commander may have to conduct a linear operation with a subordinate unit. However, the transition to nonlinear operations occurs once conditions are present.⁴² The tactical nonlinear battle has a four part cycle.

The first stage, Sensor/Acquisition, focuses on detecting and tracking the enemy using sophisticated intelligence gathering devices. Continuous tracking and engagement of the enemy by highly accurate long range fires is the second stage. Ground and air systems conduct these long range fires. The third stage is the maneuver phase. Ground maneuver forces, reinforced by fires, destroy the enemy. The recovery stage reconstitutes the combat power of friendly forces. The force disperses and the detection cycle begins again.⁴³ Rapid movements over increased space puts a premium on synchronized use of combat power. The importance of synchronization comes out in descriptions of the combat stages.

Inherent in the combat cycles are many activities that require synchronization. During the Sensor/Acquisition cycle national, theater and tactical intelligence assets all focus in time and space on finding and tracking the enemy. The fires stage adds air and ground indirect fires assets to the continuing

intelligence activity. The maneuver stage entails the synchronized use of intelligence, fire support, and maneuver forces. This must occur over expanded time and space. The final stage, recovery, again must focus on dispersed units that are beginning a new combat cycle. It is very likely that staffs must synchronize activities of all four stages during recovery. Contained in every stage is the purpose of the battle, destroying the enemy. The complexity of this battlefield concept places severe strain on the structure of the ALB-F heavy division. (Appendix C)

The ALB-F concept uses the division as a tactical, warfighting headquarters. The division loses many CS/CSS units to corps. The division will consist of a tactical and a CS/CSS headquarters designed to receive attachment of combined arms brigade packages.⁴⁴ The corps commander can then tailor his divisions as needed for his mission, area of operations, and enemy.⁴⁵ The force structure of brigades also changes significantly.

The brigade takes on a more self-contained structure. This force, consisting of tactical and logistic units habitually assigned together, operates as an entity.⁴⁶ The brigade moves independently or under division or corps control. The brigade, with increased combat, CS and CSS units in its structure, functions as

both a tactical and logistical headquarters.⁶⁷ The responsibilities for providing resources and support at higher levels of command bypasses the division.

Corps is the next level of command that contains complete combat, CS, and CSS resources. Depending on his concept of operations, the corps commander tailors his divisions with assets available to him. Like the brigade, the corps is both a tactical and logistics headquarters. The AirLand Battle-Future corps has increased responsibilities for execution of battlefield activities.⁶⁸ In particular, corps is the primary intelligence collection, reconnaissance and security, and deep battle headquarters. In this context, the division's warfighting responsibilities significantly narrow.

The ALB-F division's fighting responsibility is winning the close fight. The division has no rear or deep battle to fight.⁶⁹ Without rear and deep battles, the focus only on the close battle enables the division to accept tailored brigade packages.⁷⁰ Reduced tactical responsibilities change the division command and control functions and organization.

The division plans and fights its battles through its command and control system. The division will have a tactical and main command post. The division tactical command post directs the close battle. It collects intelligence, develops plans, and distributes products

to the brigades.⁷¹ In addition to CSS coordination and life support, the division main command post has the same capabilities of the tactical command post. The main command post operates from the tactical support area. Further, the main CP controls movement from assembly areas to the area of operations and the reconstitution phase.⁷² To support command and control, intelligence systems must be highly responsive.

Intelligence systems within the division are critical to synchronizing the battle. Timelines for planning at the division and brigade are significantly reduced. Emphasis for division intelligence is targeting for organic and reinforcing fire support and the brigades.⁷³ Corps will provide a large part of the division intelligence needs. However, the division is still responsible for combat information and human intelligence. While the close battle is the focus for the division, future intelligence technology extends the range of its intelligence assets to 150 kilometers.⁷⁴ Also, the intelligence system must link directly with the division's attack assets.

The division integrates corps and air fire support assets with its own for maximum combat power. The force field artillery headquarters is the DIVARTY headquarters. The division artillery, reinforced by corps fire support assets, provides fire support for the division. The fire support element in the division main

command post coordinates and integrates all fire support.⁷⁵ The heavy fire support battle and intense maneuver stage require effective logistics support.

The division's logistics function is to synchronize support from corps CSS units with the division base and the forward support battalions.⁷⁶ The bulk of division logistics capability is in the forward support battalions. The forward support battalion provides support to all units assigned or attached to the brigades. The AirLand Battle-Future logistics concept emphasizes maximum delivery of supplies from corps to brigade.

The AirLand Battle-Future concept effects the division's operations over time. The time dimension expands for the division in two ways. First, the division will identify and follow the enemy at longer distances through its own assets and from intelligence from higher headquarters. The time dimension is also increased by more dispersal of divisional units over the terrain. However, the close battle lasts only a short time. The division must rapidly mass its combat power, destroy the enemy quickly, and then disperse. One must also consider how the physical dimension of space interacts with time.

Nonlinearity will effect how the division will consider space. Terrain becomes important only as it helps destroy the enemy. Terrain retention is not

always important. Dispersion will create large gaps in the division area. Time and space, so closely linked, support the most important element of synchronization.

The division's purpose is paramount in synchronizing its combat power. The division must destroy an enemy force in a rapid, decisive battle. It does this while protecting its own combat power for later engagements. The requirement to focus the combat power of the division to win the close battle may cause the commander to employ linear and nonlinear tactics.

These are some of the possible implications of the AirLand Battle-Future concept on division synchronization. A planning process using AirLand Battle-Future concepts may provide an insight on how, if at all, synchronization changes in the future.

V. AirLand Battle-Future Attack

A division attack plan using AirLand Battle-Future concepts revealed its impact on synchronization. Some material used to develop the division plan is in Appendix D.

The division commander and staff begin planning activities by time, starting with maneuver. Offensive planning starts on the objective. In this case, the objective is the enemy force. Therefore, maneuver aims at striking the enemy at the time of our choosing. The battle areas assigned to brigades are their objectives. These objectives have no terrain value. Rather, battle

areas must adjust to the enemy to ensure his destruction. For example, Cunningham assigned the Sidi Rezegh airfield as an objective and gained it easily. However, his real goal, Rommel's armor, was not there.⁷⁷

The division must synchronize deployment of the brigades with arrival of the enemy in the battle areas. The division must also synchronize brigade movements with withdrawal of the corps fire/recon task force. This battle hand-off is a critical synchronization issue. Arrival of the brigades in their battle areas is important to the synchronization of other systems.

Fire support units must take positions in the battle area before maneuver elements. This ensures continuous fires on the enemy formation while the corps fire/recon task force withdraws. Forward positioning artillery units involves risk. However, this is a common condition in nonlinear battle.⁷⁸ The British artillery at Sidi Rezegh found themselves fighting German tanks, while their own armor was far to the rear.⁷⁹ Also, the division must plan for corps artillery units.

In this situation, one field artillery brigade comes under control of the division. Timing the positioning of these four fire support units must support the brigades in their battle areas. Also, commitment of the field artillery brigade presents a CSS

synchronization issue addressed later. Knowledge of enemy dispositions drives the movement and maneuver of all these forces.

Synchronized action by the division requires intelligence on location, direction and strength of the enemy. The corps intelligence system gives this information to the division. Enemy rate of advance is one of the key pieces of information needed. With the enemy's rate of advance, the staff can confirm or update the event template of the IPB.²⁰ The event template provides the expected time of arrival of the enemy in the battle area. The division's combat power can then focus at the critical time and place to destroy the enemy. Additionally, the staff must know the enemy strength.

Destruction by fire support assets is one of the key parts of the AirLand Battle-Future concept.²¹ The strength of enemy forces entering the division battle area sets the relative combat power ratios. The division attacks an enemy force, which if not attrited has nearly equal combat power.²² The corps fire/recon task force must destroy seventy percent of the enemy division. This would set favorable combat power ratios for the friendly division.²³ This destruction of enemy forces has two implications for division synchronization.

First, the enemy doctrinally stops units with 30 percent combat power to assume a hasty defense.⁶⁴ The friendly division's attack should strike the enemy before he can take up defensive positions. Theoretically, the friendly attack should still succeed.⁶⁵ However, the battle would last longer and potentially cause more damage to friendly units. Striking the enemy before he can gain the defensive advantage is a critical synchronization task.

Enemy action also presents the second synchronization implication. The enemy has also practiced passing through fresh formations into the attack when leading units reach a set level of destruction.⁶⁶ If the enemy uses this tactic, a much stronger force will arrive in the division battle area. In this case, combat power ratios would not favor a friendly attack. However, one must recognize that relative combat power is only an estimate. Many intangible factors may make the friendly attack succeed or fail under these conditions. Additionally, sustaining the combat systems is also sensitive to time.

The activities of other battlefield systems cue synchronization of combat service support. The AirLand Battle-Future logistics concept sees surges of sustainment activities after engagements.⁶⁷ However, it is more likely that sustainment surges occur throughout the battle.

The first sustainment surge in the division battle area is for the corps field artillery brigade. This unit has used ammunition and fuel during the fire/recon phase. This sustainment surge may take place during the battle handover. Therefore, the division must synchronize movement of the corps support units to the field artillery brigades.

The division artillery will require the next surge. These units forward deploy and begin fires before the brigades enter and fight in their battle areas. Therefore, a resupply of ammunition and fuel must occur to ensure that division fires can complete the division's close battle. Again, the time required to complete this resupply needs synchronization.

The maneuver brigades must resupply during or after their engagements.²⁰ This is the third sustainment surge during the division battle. If destroying the enemy takes longer than expected, resupply activities may have to occur so brigades can complete the current battle. Then, another resupply surge must occur before the division can begin a new combat cycle. However, these activities do not differ significantly from contemporary operations.

The division must essentially synchronize the same activities in the AirLand Battle-Future concept as in current doctrine. However, since the ALB-F concept envisions divisions attacking divisions, generating

superior combat power means that synchronization of all systems must occur.⁸⁷ The margin of combat power advantage is so small, that any system that does not enter the fight at the right time could be decisive. The division commander and staff must master the time dimension. Further, the activities occurring across time also take place in space.

Closely tied to time, battlefield activities have space relationships. Dispersion is an essential part of the AirLand Battle-Future concept. The impact on maneuver is that movements must occur so forces enter battle relative to the enemy. Since the division fights only the close battle, once engaged it synchronizes its combat power within the battle area.⁸⁸ The concentration of combat power within the battle area requires detailed terrain and route management.

The following are some of the activities the division must synchronize within its battle area:

Movement routes and positions for organic and attached artillery, air defense, engineer, intelligence and CS/CSS units.

Routes and positions of corps support groups.

Withdrawal routes for the corps fire/recon task force.

Routes and positions of other corps units (For example signal, intelligence).

These same activities require coordination in current operations.⁸⁹ However, nonlinear conditions and more

dispersion complicate the task. To deliver maximum combat power at the decisive time and place in any direction requires enhanced synchronization.

Positioning fire support assets on the nonlinear battlefield presents many possibilities. The range of fire support systems allows positioning outside the battle area. So positioned, the fire support system can cover its assigned battle area. However, massing fires of all systems in one battle area could require repositioning. This is also not uncommon in current operations.⁹² However, extended distances of nonlinear battle could make this repositioning untimely and impractical. To maximize fires, fire support units may take up a central position in the battle area. Around this "pivot of maneuver," brigades would maneuver to apply direct fires. Both maneuver and fire support units depend on the intelligence system for information on enemy use of space.

The division intelligence system operates over longer distances. As discussed earlier, the division conducts surveillance out to 150 kilometers and targeting to 70 kilometers.⁹³ The importance of this distance to synchronization is movement rate of the enemy. The intelligence system must provide continuous updates on the speed of the enemy. As the enemy moves over space, timing friendly actions must adjust. The intelligence system uses time and space to provide

information critical to synchronization. The effects of dispersion on friendly and enemy units includes the sustainment activities.

The CSS system must conduct sustainment operations over long distances. Rommel's supply line at Tobruk stretched 300 miles to Bengazi, nearly 1000 miles to Tunis.⁷⁴ This condition emphasizes the sustainment imperative of anticipation.⁷⁵ The forward support battalions position in the battle area with their brigades. This provides emergency ammunition and fuel resupply. To ensure delivery of supplies from corps to forward support battalions when required is the synchronization task of the division support command. This task differs somewhat from current support doctrine. However, nonlinear conditions further complicate the time and distance considerations. Synchronization in time and space aims at accomplishing the mission, the division's purpose.

The division's purpose is the most important factor in synchronization. All activities in each operating system must focus on the purpose. While this seems obvious, ensuring unity of purpose is very difficult to achieve. Success depends on the commander's ability to visualize how he wants to destroy the enemy. It also depends on how well he can express his vision to his subordinates. And finally, how well subordinates .pa

understand the commander's vision and translate it into action is critical to synchronization. The commander's vision includes how his units move on the battlefield.

Nonlinear maneuver must gain positional advantage. The timing problem described earlier is critical to achieving the division's purpose. When like-sized units meet in battle, the side that can best synchronize its systems has the advantage. Nonlinear maneuver must seek enemy flanks with concentrated mass. This requires exquisite synchronization of maneuver forces.

Winning a nonlinear battle depends on faultless synchronization of fire support. The fire phase must work to near perfection to set conditions for the division close battle. The division will not achieve its purpose if it must meet an unmolested enemy force. A larger part of the fires phase is knowing where major enemy elements are most of the time.⁷⁶

Intelligence systems become more important than ever.⁷⁷ The division plan depends on timely, accurate intelligence on the enemy. The division cannot lose the enemy as did General Cruewell on 20 November 1941.⁷⁸ The enemy is the focus of the division's purpose. The functions of all other systems get synchronized through the products of the intelligence system. Getting the division into combat also requires an ability to keep it fighting.

The division's responsibilities for sustainment shrink in ALB-F. However, the division support command is still responsible for synchronizing logistics." As with the other systems described, the task is essentially the same. Conditions of nonlinearity compound the difficulty of the problem. As such, the AirLand Battle-Future concept has an important impact on synchronization.

VI. Conclusions

"There has never been a battle fought at such an extreme pace and with bewildering vicissitudes of fortune. ...a whirlwind battle fought on ground which allowed complete freedom of maneuver and handled by commanders who were prepared to throw in their last reserves to achieve victory."

Von Mellethin
Panzer Battles, p. 66

Exquisite - Marked by flawless craftsmanship or by beautiful, ingenious, delicate, or elaborate execution.
Webster's Ninth New
Collegiate Dictionary

The conditions of nonlinear battle will indeed require exquisite synchronization. Expanded time and space dimensions makes mastery of those elements essential for success. This brief planning exercise using AirLand Battle-Future concepts shows how important synchronization becomes. The emphasis on synchronization in future concepts highlights the Army's current trouble with this tenet.

The Battle Command Training Program is revealing weaknesses in staff skills critical to synchronization.¹⁰⁰ As discussed earlier, division commanders and their staffs have trouble synchronizing combat power under present battlefield conditions.

An essential skill that must improve is the commander's ability to visualize the battle, develop his intent, and express it to his staff.¹⁰¹ BCTP is improving the ability of division staffs to execute AirLand Battle doctrine.¹⁰² While the Army is making progress, AirLand Battle-Future will compound the synchronization task.

Implications of synchronizing nonlinear tactical operations became clear in this study. The corps fire/recon task force and support elements and division units will move through the division battle areas at the same time. Simultaneous movement will require careful, detailed planning.

The intelligence systems must provide information that allows the division to hit the enemy before:

1. The enemy assumes a hasty defense.
2. A fresh division passes through and continues the attack. This is important considering the next implication.

To sustain division combat power, CSS units must surge to complete the current battle. At the end of close battle, another CSS cycle occurs.

The division attacks a division. The division needs exquisite synchronization to generate enough combat power to win.

Achieving exquisite synchronization is, not surprisingly, a training matter. The points made by the ALB-F office hold true for current and future commanders and staffs. Staffs must learn to function under dynamic, intense conditions. Developing a high performance staff is a training priority.¹⁰³

Leader development must focus on making decisions with accurate but incomplete information. Training on information and decision aids is essential.

The most important part of training a high performance staff involves concepts and intent.¹⁰⁴ The commander must know how to conceptualize the battle, frame his intent, and express it to the staff. The staff must understand the intent and translate it into action. They must do this with a mastery of time, space, and technical information.

Understanding intent, developing concepts, seeing the battle are difficult. It is hard to quantify these ideas. Frequently, in discussions on improving synchronization, the solution offered is another battlefield computer. This is not the answer.

The answer is commanders and staff that know doctrine and the interrelationship of battlefield systems. These soldiers must understand the combat

environment, and communicate to insure understanding. Commanders and staffs must master time, space, and purpose. Only then can they become master craftsmen, creating exquisitely synchronized action out of apparent chaos.

ENDNOTES

Part I

- ¹ James E. Zanol, MAJ, Preparing for the synchronization process: Mechanized battalion task force, MMAS thesis, U.S. Army Command and General Staff College, Fort Leavenworth, Kansas, 1990, p. 2.
- ² Combined Arms Center, USACGSC Directors OPD Read Ahead Packet: AirLand Battle-Future, Fort Leavenworth, Kansas, 31 Jul 1990, p. 93. Hereafter called Read Ahead.
- ³ Combined Arms Center, Evolution of the Army using insights from: AirLand Battle-Future, Final Coordinating Draft, Fort Leavenworth, Kansas, 11 Sep 1990, p. 6. Hereafter called Evolution of the Army.
- ⁴ FM 100-5, Operations, Headquarters, Department of the Army, Washington D.C., 1986, p. 17.
- ⁵ Clyde L. Long, MAJ, Synchronization of combat power at the task force level: Defining a planning methodology, MMAS thesis, U.S. Army Command and General Staff College, Fort Leavenworth, Kansas, 1989, p. 47-48.
- ⁶ Ibid, p. 49.
- ⁷ Ibid, p. 46-47.
- ⁸ FM 100-5, p. 17.
- ⁹ Clausewitz, Carl, Principles of War, Reprinted in Roots of Strategy Book 2, Stackpole Books: Harrisburg, PA., 1987, p. 350.
- ¹⁰ Ibid, p. 319, 334.
- ¹¹ Jomini, Henri, Summary of the Army of War, Reprinted in Roots of Strategy Book 2, Stackpole Books: Harrisburg, PA., 1987, p. 461.
- ¹² Ibid, p.506.
- ¹³ Tzu, Sun, The Art of War, Translated by Samuel B. Griffith, Oxford University Press: New York, 1971, p. 92.
- ¹⁴ Clausewitz, p. 319.
- ¹⁵ Ibid, p. 325.
- ¹⁶ Jomini, p. 464-478.

- 17 Ibid, p. 492.
- 18 Sun Tzu, p. 106.
- 19 Clausewitz, p. 323.
- 20 Ibid, p. 350.
- 21 Jomini, p. 461.
- 22 Sun Tzu, p. 83.

Part II

- 23 Von Mellenthin, F.W., MG, Panzer Battles, Ballantine Books, New York, 1971, p. 74.
- 24 Strawson, J., The Battle for North Africa, Charles Scribner and Sons, New York, 1969, p. 93.
- 25 Ibid, p. 93.
- 26 Barnett, Correlli, The Desert Generals, Indiana University Press, Bloomington, 1960, p. 85.
- 27 Von Mellenthin, p. 86.
- 28 Baldwin, Hanson, The Crucial Years 1939-1941, Harper and Row, New York, 1976, 262.
- 29 Barnett, p. 97.
- 30 Ibid, p. 99.
- 31 Pitt, Barrie, The Crucible of War 2 Auchinleck's Command, Papermac, London, 1986, p. 53-67.
- 32 Barnett, p. 101.
- 33 Strawson, p. 104.
- 34 Strawson, p. 105.

Part III

- 35 U.S. Army, FM 71-100 Division Operations, Fort Leavenworth, Kansas, August 1990, p. iii.
- 36 Ibid, p. 1-25.
- 37 Ibid, p. iv.
- 38 Ibid, p. 3-17.

39 Ibid, p. 1-20.

40 Ibid, p. 1-21.

41 Morgan, T.D., "BCTP, Preparing for War," Military Review, Fort Leavenworth, Kansas, November 1989, p.4.

42 Ibid, p. 5.

43 Spigelmire, M.F., MG, and Tuttle, H.S., MAJ, "BCTP and the Victory Division." Military Review, Fort Leavenworth, Kansas, October 1988, p. 23.

44 Frandsen, H.C., The Battle Command Training Program: An evaluation of BCTP and the application of AirLand Battle, Advanced Military Studies Program, Command and General Staff College, Fort Leavenworth, Kansas, 27 Nov 1989, p. 20-22.

45 Center for Army Lessons Learned (CALL), Corps-Division Lessons Learned, Combined Arms Training Activity, Fort Leavenworth, Kansas, November 1989, p. 7-8. Also see Frandsen, p. 16-17.

46 CALL, p. 10-11.

47 Morgan, p. 9.

48 CALL, p. 15.

49 Frandsen, p. 31.

50 CALL, p. 19.

Part IV

51 Evolution of the Army, p. ii.

52 Ibid, p. ii.

53 Read Ahead, p. 93.

54 Evolution of the Army, p. 40.

55 AirLand Battle-Future Office, Insights from General Foss, Fort Leavenworth, Kansas, undated, p. 1.

56 Ibid, p. 1.

57 Ibid, p. 8. The operations listed are:

Contingency Operations
Deterrence Operations
Peacekeeping
Humanitarian
Nation assistance
Counterterrorism
Counterinsurgency
Counternarcotics
Forward deployment
Reinforcement operations

58 Ibid, p. 9.

59 Ibid, p. 10.

60 Ibid, p. 17.

61 Ibid, p. 18.

62 Ibid, p. 18.

63 Ibid, p. 20.

64 Evolution of the Army, p. 30.

65 Carl E. Vuono, GEN, A Strategic Force for the 1990s and Beyond, CSA White Paper, Headquarters Department of the Army, January 1990, p. 30.

66 Evolution of the Army, p. 30.

67 Ibid, p. 30.

68 Ibid, p. 34.

69 Combined Arms Center, AirLand Battle-Future Command and Control White Paper (Draft), Fort Leavenworth, Kansas, 3 May 1990, p. 3. Hereafter called C2 White Paper.

70 Ibid, p. 9.

71 Ibid, p. 4.

72 Ibid, p. 4.

73 U.S. Army Intelligence Center, AirLand Battle-Future Intelligence White Paper, Fort Huachuca, Arizona, 3 May 1990, p. 7. Hereafter called Intelligence White Paper.

74 Ibid, p. 7.

75 U.S. Army Field Artillery Center, Fire Support for Nonlinear Warfare White Paper (Draft), Fort Sill, Oklahoma, 1 May 1990, p. B-1, C-2. Hereafter called Fire Support White Paper.

76 U.S. Army Logistics Center, Concept for Logistical Support on the Nonlinear Battlefield, Fort Lee, Virginia, undated, p. 4. Hereafter called Logistical Support.

Part V

77 Pitt, p. 48. See also Scott, p. 73.

78 Evolution of the Army, p. 17.

79 Pitt, p. 83.

80 Headquarters, Department of the Army, FM 34-130 Intelligence Preparation of the Battlefield, Washington D.C., May 1989, p 4-59.

81 Evolution of the Army, p. 24.

82 U.S. Army Command and General Staff College, SI 100-9 The Command Estimate, Fort Leavenworth, KS, 1 July 1989, p. 3-3.

83 Ibid, p. 3-5.

84 U.S. Army Combined Arms Center Threats Directorate, FI 100-2-1 The Soviet Army Operations and Tactics, Fort Leavenworth, KS, 18 June 1990, p. 4-146.

85 Command Estimate, p. 3-5.

86 Briefed by MAJ Terry Wilson, AMSP Corps exercise after action review, 31 Oct 1990.

87 Evolution of the Army, p. 26.

88 Ibid.

89 Read Ahead.

90 C2 White Paper, p. 4.

91 FM 71-100, p. 1-11.

92 Ibid, p. 2-3.

93 Intelligence White Paper, p. 7.

- 94 Pitt, p. 162-163.
- 95 FM 100-5, p. 62.
- 96 AirLand Battle-Future Office, Insights from General Foss, p. 1.
- 97 Intelligence White Paper, p. 1.
- 98 Von Mellethin, p. 78.
- 99 Logistical Support, p. 4.

Part VI

- 100 Frandsen, p. 31.
- 101 Spigelmire, p. 21.
- 102 Frandsen, p. 38.
- 103 Evolution of the Army, p. 31.
- 104 Ibid, p. 33.

BIBLIOGRAPHY

Books

Baldwin, H.W.. The Crucial Years 1939-1941. New York: Harper & Row. 1976

Barnett, Correlli. The Desert Generals. Bloomington: Indiana University Press. 1960.

Clausewitz, Carl. Principles of War. Reprinted in Roots of Strategy Book 2. Harrisburg, PA: Stackpole Books. 1987.

Crisp, Robert. Brazen Chariots. New York: Bantam Books. 1978.

Jomini, Henri. Summary of the Art of War. Reprinted in Roots of Strategy Book 2. Harrisburg, PA: Stackpole Books. 1987.

Macksey, K.L.. Afrika Korps. New York: Ballantine Books. 1968.

Pitt, Barrie. The Crucible of War 2 Auchinleck's Command. London: Papermac. 1986.

Strawson, J. The Battle for North Africa. New York: Charles Scribner & Sons. 1969.

Tzu, Sun. The Art of War. Translated by Samuel B. Griffith. New York: Oxford University Press. 1971

Von Mellenthin, F.W.. Panzer Battles. New York: Ballantine Books. 1971.

Young, Desmond. Rommel: The Desert Fox. New York: Harper & Row. 1950.

Unpublished Documents

Barron, M.J., MAJ. C3 on the AirLand Battlefield: Striking a balance between communication means and information needs. Monograph. School of Advance Military Studies, Command and General Staff College, Ft. Leavenworth, KS. 1988.

Butler, W.G., MAJ. How should the Brigade and Division commander assess success or failure on the AirLand Battlefield? Monograph. School of Advance Military Studies, Command and General Staff College, Ft. Leavenworth, KS. 1986.

Davenport, B.W., MAJ. Tactical Survivability of Division Combat Service Support units on the AirLand Battlefield. Monograph. School of Advanced Military Studies, Command and General Staff College, Ft. Leavenworth, KS. 1985.

Frandsen, H.L., MAJ. The Battle Command Training Program: An evaluation of BCTP and the application of AirLand Battle. Monograph. School of Advanced Military Studies, Command and General Staff College, Ft. Leavenworth, KS. 1986.

Everett, M.W., MAJ. Tactical Generalship: A view from the past and a look toward the 21st Century. Monograph. School of Advanced Military Studies, Command and General Staff College, Ft. Leavenworth, KS. 1986.

Idiart, P.L., MAJ. Time-on-target: Tactical organization and the massing of Divisional Field Artillery fires on the AirLand Battlefield. Monograph. School of Advanced Military Studies, Command and General Staff College, Ft. Leavenworth, KS. 1986.

Long, Clyde L. Synchronization of Combat Power at the Task Force Level: Defining a Planning Methodology. MMAS Thesis. Command and General Staff College, Fort Leavenworth, KS. June 1989.

Mamaux, D.H., MAJ. U.S. Army and Non-linear Operations: Does training match the doctrine? Monograph. School of Advanced Military Studies, Command and General Staff College, Ft. Leavenworth, KS. 1986.

McElwee, J.W., MAJ. A first cut at Doctrine for automation of Division command and control. Monograph. School of Advanced Military Studies, Command and General Staff College, Ft. Leavenworth, KS. 1985.

Mock, D.C., MAJ. A look at Deep Operations: The option of Deep Maneuver. Monograph. School of Advanced Military Studies, Command and General Staff College, Ft. Leavenworth, KS. 1986.

Mixon, R. W., MAJ. Taking the Ultimate Risk: Commanding and Controlling Maneuver Forces in Tactical Deep Operations. Monograph. School of Advanced Military Studies, Command and General Staff College, Ft. Leavenworth, KS. 1986.

Runals, S.E., MAJ. Does current U.S. tactical Command and Control Doctrine meet the requirements for today's High Intensity Battlefield? Monograph. School of Advanced Military Studies, Command and General Staff College, Ft. Leavenworth, KS. 1985.

Scott, G.L., MAJ. Considerations for Deep Maneuver: Lessons from North Africa, 1941-1942. MMAS Thesis. Command and General Staff College, Ft. Leavenworth, KS. 1985.

Twohig, J.J., MAJ. Should the current Direct Support Artillery Battalions of the Heavy Division be organic to the Maneuver Brigade? Monograph. School of Advanced Military Studies, Command and General Staff College, Ft. Leavenworth, KS. 1986.

Vuono, Carl E. A Strategic Force for the 1990s and Beyond, CSA White Paper. Headquarters, Department of the Army. Washington D.C.. January 1990.

Zanol, James E. Preparing for the Synchronization Process: Mechanized Battalion Task Force Level. MMAS Thesis. Command and General Staff College, Fort Leavenworth, KS. June 1990.

Articles

Burke, J.T., COL (Ret). "The Firepower Revolution." Army. Association of the United States Army. November 1989. pp. 51-60.

Morgan, T.D., LTC. "BCTP: Preparing for War." Military Review. Command and General Staff College, Ft. Leavenworth, KS. November 1989. pp. 49-56.

Franks, T.R., COL and Tetu, W.J., LTC. "Firepower on the move in heavy forces." Army. Association of the United States Army. July 1989. pp. 63-68.

Pokorny, A.G., COL, Mooney, D.J., LTC and West, L.A., LTC. "Field Artillery in the 21st Century." Military Review. Command and General Staff College, Ft. Leavenworth, KS. August 1989. pp. 15-22.

Rogers, J.B., COL. "Synchronizing the AirLand Battle." Military Review. Command and General Staff College, Ft. Leavenworth, KS. April 1986. pp. 65-71.

Snow, J.J., LTC. "AirLand Battle doctrine tenets in Opposition." Military Review. Command and General Staff College, Ft. Leavenworth, KS. October 1987. pp. 63-67.

Spigelmire, M.F., MG and Tuttle, H.S., MAJ. "BCTP and the Victory Division." Military Review. October 1988. Command and General Staff College, Ft. Leavenworth, KS. October 1988. pp. 20-26.

Stiles, E.J.. "Automated Fire Control: A new generation." Army. Association of the United States Army. July 1989. pp. 59-61.

Government Publications

Center for Army Lessons Learned, Combined Arms Training Activity, Ft. Leavenworth, KS. Corps-Division Lessons Learned. #89-4. November 1989.

U.S. Army. Field Manual 34-130, Intelligence Preparation of the Battlefield. Washington D.C. Headquarters, Department of the Army, May 1989.

U.S. Army. Field Manual 71-100, Division Operations. Washington D.C.: Headquarters, Department of the Army, August 1990.

U.S. Army Combined Arms Center Threats Directorate. Field Manual 100-2-1, The Soviet Army Operations and Tactics (Draft). Fort Leavenworth, Kansas, 18 June 1990.

U.S. Army. Field Manual 100-5, Operations. Washington, D.C.: Headquarters, Department of the Army, 5 May 1986.

U.S. Army. Student Text 100-9, The Command Estimate. Fort Leavenworth, Kansas: U.S. Army Command and General Staff College, 1 July 1990.

AirLand Battle-Future Documents

U.S. Army Combined Arms Center. USACGSC Directors OPD Read Ahead Packet: AirLand Battle-Future, Fort Leavenworth, Kansas. 31 Jul 1990.

U.S. Army Combined Arms Center. Evolution of the Army using insights from: AirLand Battle-Future, Final Coordinating Draft. Fort Leavenworth, Kansas, 11 Sep 1990.

U.S. Army Combined Arms Center. AirLand Battle-Future Command and Control White Paper (Draft). Fort Leavenworth, Kansas, 3 May 1990.

U.S. Army Intelligence Center. AirLand Battle-Future: Intelligence White Paper. Fort Huachuca, Arizona, 3 May 1990.

U.S. Army Field Artillery Center. Fire Support for Nonlinear Warfare White Paper (Draft). Fort Sill, Oklahoma, 1 May 1990.

U.S. Army Logistics Center. Concept for Logistical Support on the Nonlinear Battlefield. Fort Lee, Virginia, undated.

U.S. Army AirLand Battle-Future Office. Insights from General Foss. Fort Leavenworth, Kansas, undated.

APPENDIX A

DEFINITIONS

Taken from Evolution of the Army using Insights from: AirLand Battle-Future, Final Coordinating Draft, Fort Leavenworth, Kansas, 11 September 1990.

Battle Area - A tactical subdivision of an areas of operations where the commander intends to employ all combat means under his command or control to destroy the opposing force.

Battlefield Activities - A task, event, procedure or group of procedures which can be reduced to time.

Detection Area - A defined area which includes the areas of operations but varies in size and shape based on regional, operationsl and echelon considerations, in which the commander develops intelligence about all future enemy activities which might affect the friendly force throughout the duration of the current of future operations

Tactical Support Area - A tactical subdivision of an area of operations where the commander intends to protect the force, preserve his freedom of action and continuity of operations, and assure uninterrupted support of the battle area and reconstitution of combat power.

Nonlinear tactics - A battlefield upon which the command either by choice or the lack of maneuver forces to cover all the terrain, has placed his forces in dispersed, noncontiguous areas from which he can operate to destroy enemy forces whthin his area of operations. Emphasis is on destruction of enemy force rather than terrain retention.

APPENDIX B

Map 6 The first battle of Sidi Rezegh: November 22nd, 1941

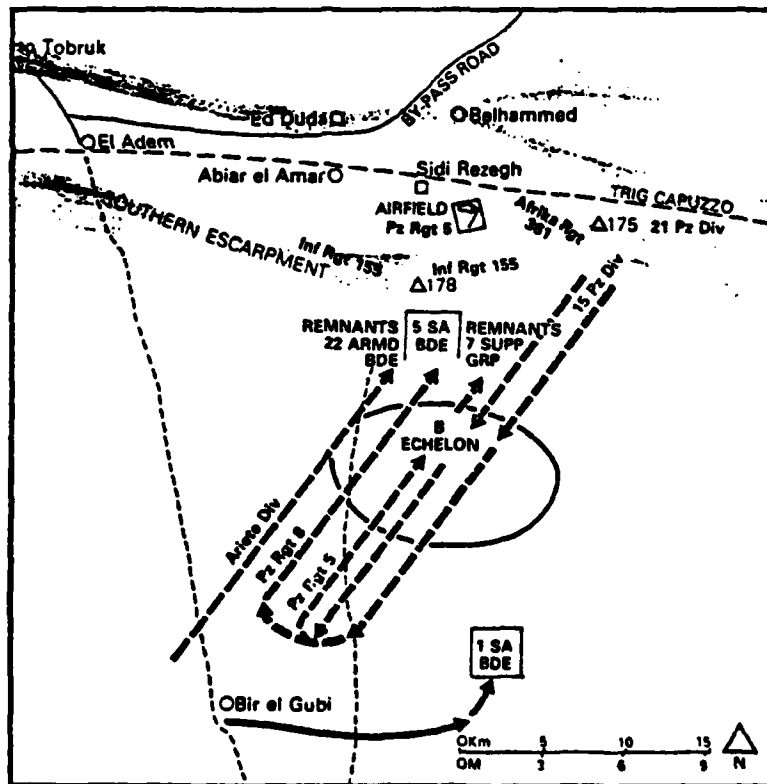
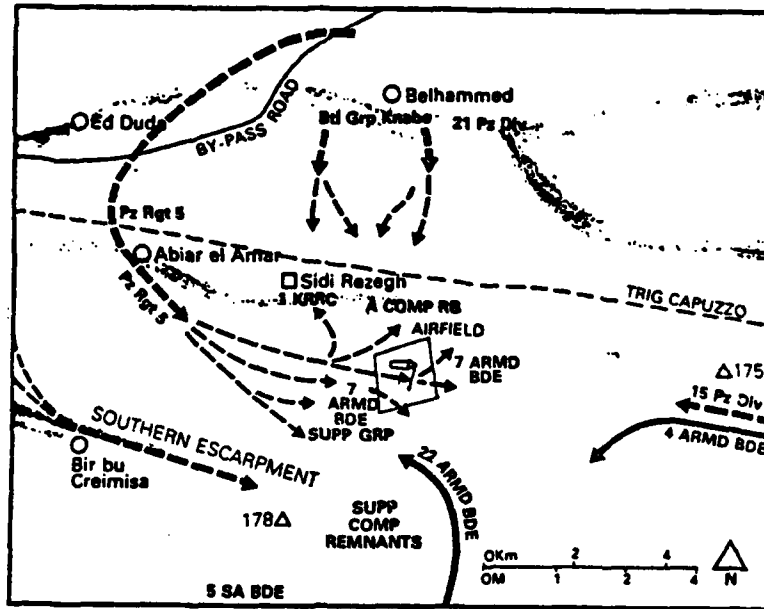

Map 7 Totensonntag: November 23rd, 1941

Map from Barrie Pitt, The Crucible of War 2 Auchinleck's Command, Papermac, London, 1986, pp. 83,94.

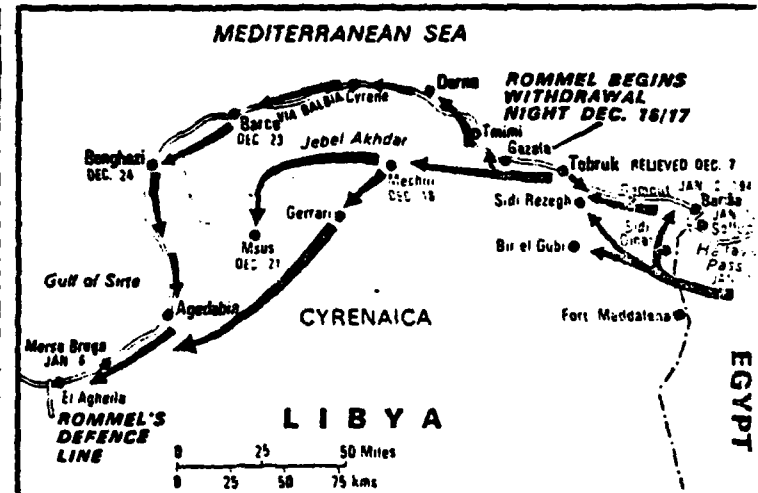
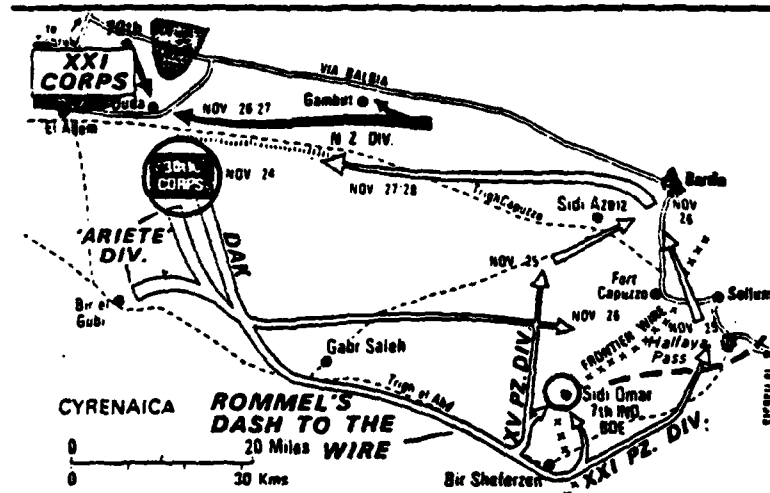
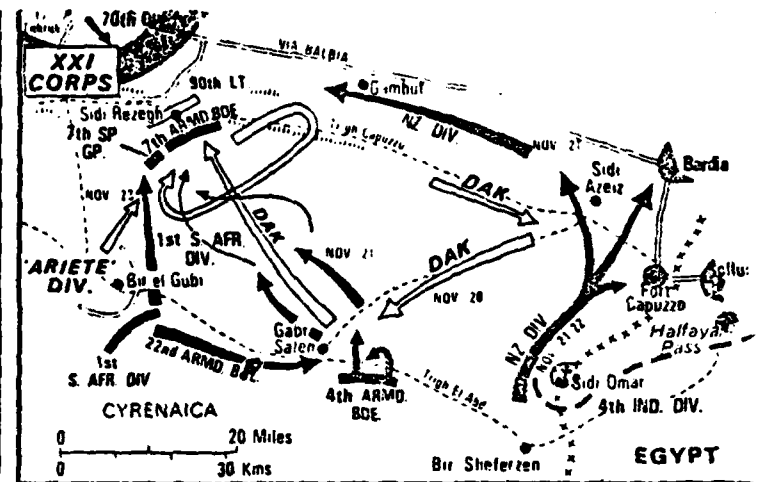
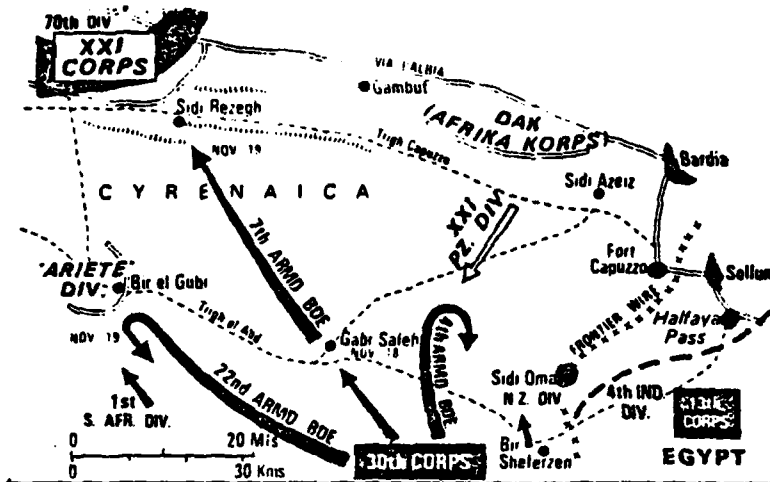

Maps from K.J. Macksey, *The Afrika Korps*, Ballentine Books, New York, 1968, p.48.

APPENDIX C

AirLand Battle - Future Armored Division

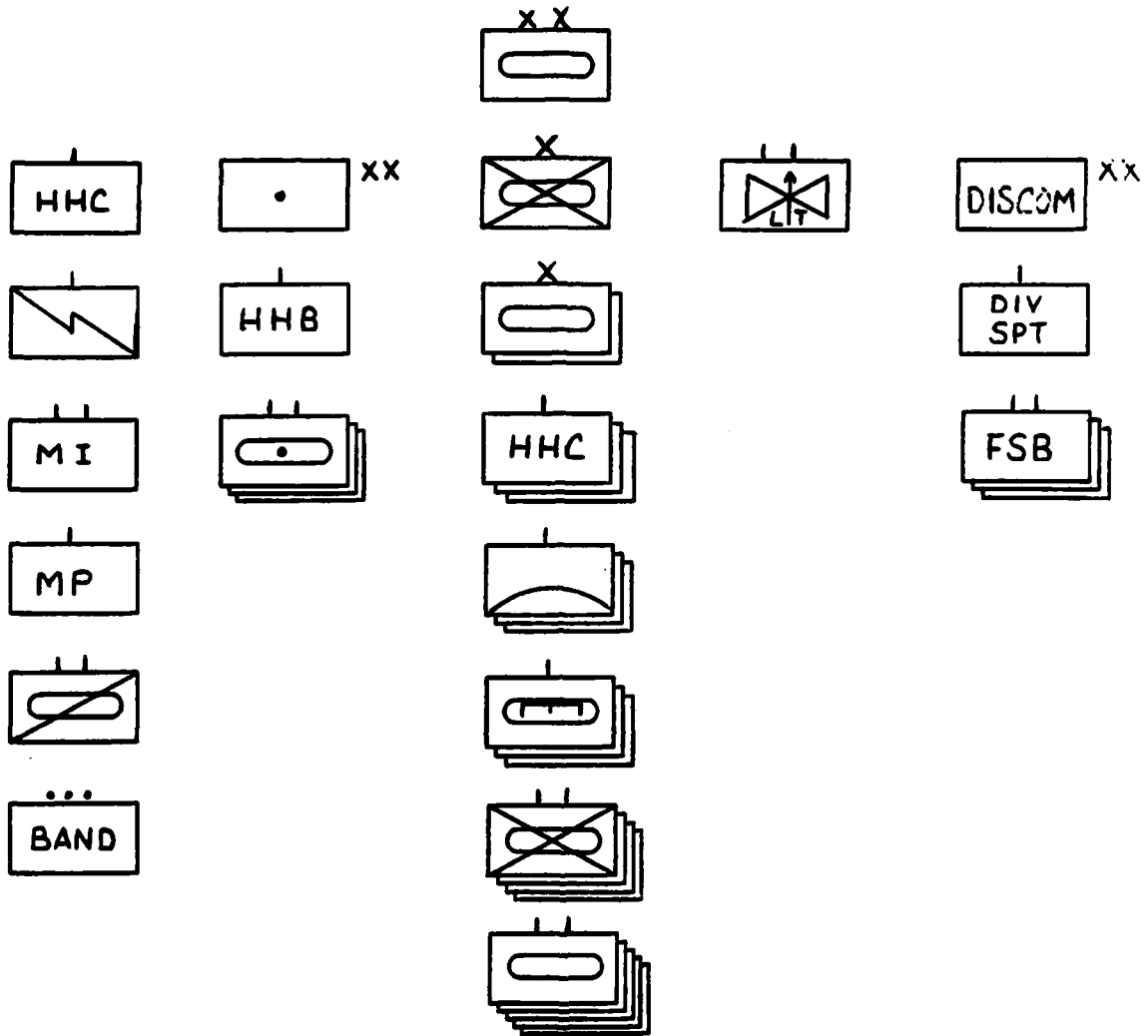

Taken from AirLand Battle-Future Alternate Base Case Study, Phase I, Combined Arms Center, Fort Leavenworth, Kansas, 26 Feb 1990.

AirLand Battle - Future Armored Brigade

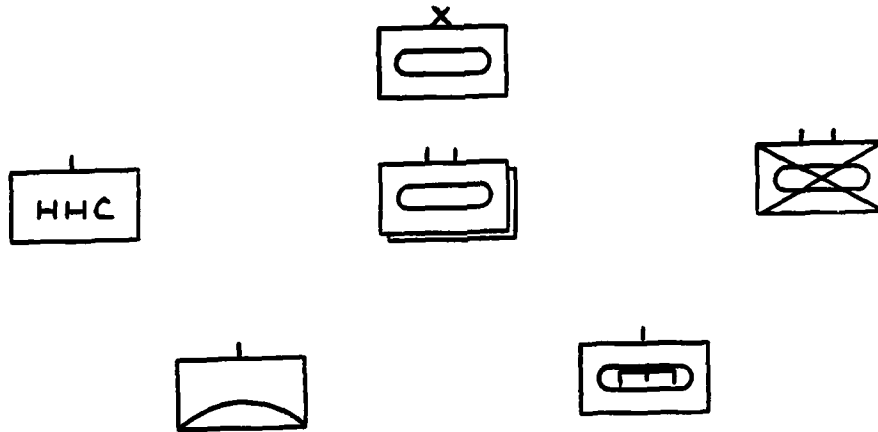

Taken from AirLand Battle-Future Alternate Base Case Study, Phase I, Combined Arms Center, Fort Leavenworth, Kansas, 26 Feb 1990.

APPENDIX D

AirLand Battle-Future Attack Scenario

Testing AirLand Battle-Future synchronization concepts requires a tactical setting. An armored division is ordered to attack to destroy enemy forces west of Fulda and on order continue the attack.

The enemy is a combined arms army formed in two echelons. The first echelon consisted of two motorized rifle divisions, the second echelon is a motorized rifle division and a tank division. The enemy is attacking southwest along a line Fulda to Frankfurt.

The motorized rifle division that enters the division battle area has also changed and modernized. The MRD consists of two BTR regiments and two BMP regiments. The division has a 40 percent reduction of tanks, from 271 to 161. However, the division increases strength in personnel, artillery, anti-tank, air defense, and engineer capability. For example, the anti-tank and air defense batteries in the motorized rifle regiments increase to battalions.

The division's battle area consists of varied terrain. Bounded on the south by the Kinzig River, the terrain becomes more open with areas suitable for mechanized forces. Fulda is the largest urban area in the battle area, on its east boundary. The battle area straddles two major avenues of approach. The Kinzig

River/Highway 40 in the south, and Highway 275 form the two major routes for the enemy. A supporting approach exists in the center of the sector.

The division consists only of its organic elements at the start of the battle. Proposed division structure is at Appendix B. Corps augmentation of the division is discussed later.

The heavy division is in position in the dispersal areas. It must conduct its attack in 24 hours. This is the expected time of arrival of the enemy in the battle area. To complete the situation, it is essential to have two important elements of the corps and division operations order.

Commander's intent and concept of operations are the heart of the operations order. The division commander must understand the intent of the commanders two levels above. The Army Group commander's intent is to attack to stop the attack of the enemy to allow diplomatic action to stabilize the international situation. This attack must also set the conditions for continuing operations to restore pre-hostility boundaries.

The corps commander's intent is to destroy the lead enemy divisions west of Fulda. This part of the battle must take little time. The corps completes the destruction of the CAA in battle areas east of Fulda, setting the stage for the eastward movement of the corps.

The Corps concept of operations calls for two divisions to destroy the lead enemy divisions in battle areas west of Fulda between Highway B40 and Autobahn A7. The third division moves to a battle area east of Fulda. There it stops the second echelon divisions, accepting linear conditions if necessary. The Combat aviation brigade attacks in a battle area in the vicinity of Eiterfeld against second echelon divisions. The armored cavalry regiment is corps reserve. The corps deep battle focuses on holding the main body of the enemy second echelon army east of the Thuringer Wald.

The division commander's intent is to force the enemy to commit to the B40 approach with his second echelon regiments. The division will portray strong positions in the area of Fulda and Lauterbach.

The additional resources received from corps takes several forms. As the corps fires/recon task force withdraws, one field artillery brigade is put under operational control of the division. This unit consists of a brigade headquarters, three cannon battalions, and one multiple rocket launcher battery.

Corps also provides additional engineer units to the division. These units within the time available reinforce the terrain to support the commander's intent. Obstacles that force the enemy main body to the B40 approach accomplish that task.

Friendly Combat Power

Tank Brigades (x 2)

2 tank battalions (2x2.50)	5.00
1 mech inf battalions (1x2.0)	2.00
1 engineer company	-
1 air defense company	-
1 artillery battalion (DS)	<u>2.00</u>
	9.00 (x2) 18.00

Mechanized Infantry Brigade

2 mech inf battalions (2x2.0)	4.00
1 tank battalion	2.50
1 engineer company	-
1 air defense company	-
1 artillery battalion (DS)	<u>2.00</u>
	8.50

Division Cavalry Squadron 2.0

Combat Aviation Battalion 4.0

Corps FA Brigade

Artillery battalion (3x2.00)	6.00
1 MRLS battalion	2.00

Division Combat Power

<u>40.5</u>
36.4 (90%)
32.4 (80%)
28.4 (70%)
24.3 (60%)
20.3 (50%)

Enemy Combat Power

Motorized Rifle Regiments (BTR)

3 mech inf battalion (BTR) (3x1)	3.00
1 tank battalion	2.0
1 AT battalion	1.0
1 artillery battalion	<u>2.0</u>
	8.00 (x2) 16.00

Motorized Rifle Regiments (BMP)

3 mech inf battalion (BMP) (3x1.5)	4.50
1 tank battalion	2.0
1 AT battalion	1.0
1 artillery battalion	<u>2.0</u>
	9.5 (x2) 19.00

Attack helicopter battalion 2.0

Reconnaissance battalion 1.0

Division artillery group

3 FA battalion (3x2.0) 6.0

3 MRL batteries (3x1.0) 3.0

9.0

Division Combat Power

47.0
42.3 (90%)
37.6 (80%)
32.9 (70%)
28.2 (60%)
23.5 (50%)
18.8 (40%)
14.1 (30%)
9.4 (20%)