

2

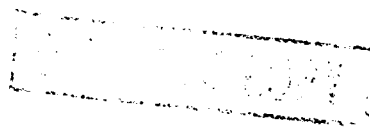

CRANFIELD INSTITUTE OF TECHNOLOGY

AD-A233 623

RADIAL INFLOW TURBINE STUDY

FOURTH INTERIM REPORT

by

Dr S Hamid
Prof R L Elder

DECEMBER 1990

United States Army
EUROPEAN RESEARCH OFFICE OF THE US ARMY
London England

CONTRACT NUMBER: DAJA45-89-C-0006
CRANFIELD REFERENCE: 06/769E
PROJECT START DATE: 1st January 1989
PROJECT COMPLETION DATE: 30th June 1993

Department of Turbomachinery & Engineering Mechanics
School of Mechanical Engineering
Cranfield Institute of Technology
Cranfield, Bedford, MK43 0AL

Approved for Public Release; distribution unlimited

9 1 9 2 0 1 7

SECURITY CLASSIFICATION OF THIS PAGE

REPORT DOCUMENTATION PAGE

Form Approved
OMB No. 0704-0188

1a. REPORT SECURITY CLASSIFICATION Unclassified		1b. RESTRICTIVE MARKINGS	
2a. SECURITY CLASSIFICATION AUTHORITY		3. DISTRIBUTION / AVAILABILITY OF REPORT Distribution unlimited	
2b. DECLASSIFICATION / DOWNGRADING SCHEDULE		4. PERFORMING ORGANIZATION REPORT NUMBER(S) O6/769E(4)	
4. PERFORMING ORGANIZATION REPORT NUMBER(S) O6/769E(4)		5. MONITORING ORGANIZATION REPORT NUMBER(S)	
6a. NAME OF PERFORMING ORGANIZATION Cranfield Institute of Technology	6b. OFFICE SYMBOL (if applicable)	7a. NAME OF MONITORING ORGANIZATION European Research Office	
6c. ADDRESS (City, State, and ZIP Code) Cranfield, Bedford, MK43 QAL		7b. ADDRESS (City, State, and ZIP Code) 223 Old Marylebone London NW1 5TH	
8a. NAME OF FUNDING / SPONSORING ORGANIZATION SACCE - RCO Burtonwood	8b. OFFICE SYMBOL (if applicable)	9. PROCUREMENT INSTRUMENT IDENTIFICATION NUMBER R & D 5824-AN-01	
8c. ADDRESS (City, State, and ZIP Code) HQ 47th Area Support Group Burtonwood Road, Great Sankey Warrington, Cheshire, WA5 1UN		10. SOURCE OF FUNDING NUMBERS	
		PROGRAM ELEMENT NO.	PROJECT NO.
		TASK NO.	WORK UNIT ACCESSION NO.
11. TITLE (Include Security Classification) Radial Inflow Turbine Study			
12. PERSONAL AUTHOR(S) Dr S Hamid Professor R L Elder			
13a. TYPE OF REPORT INTERIM	13b. TIME COVERED FROM 15.7.90 TO 21.12.90	14. DATE OF REPORT (Year, Month, Day) 1991, January	15. PAGE COUNT 8
16. SUPPLEMENTARY NOTATION R7-5.29/IH			
17. COSATI CODES		18. SUBJECT TERMS (Continue on reverse if necessary and identify by block number)	
FIELD	GROUP	Radial Turbines	
	SUB-GROUP	Laser Anemometry	
19. ABSTRACT (Continue on reverse if necessary and identify by block number)			
<p>The radial inflow turbine is a primary component used both in small gas turbines and turbocargers. Better understanding of the flow processes occurring within the small passages of the machine could well result in the improved design of units. As most of the detailed aerodynamics is still ill-defined, a joint research project with the objective of improving our understanding has been instigated by Cranfield, the US Army and Turbomach (San Diego).</p> <p>This document gives the fourth report on the project. It describes the manufacture of the window arrangement, the preparation of seeding systems for the laser anemometer, assembly and trial of the anemometer.</p>			
20. DISTRIBUTION / AVAILABILITY OF ABSTRACT <input type="checkbox"/> UNCLASSIFIED/UNLIMITED <input type="checkbox"/> SAME AS RPT. <input type="checkbox"/> DTIC USERS		21. ABSTRACT SECURITY CLASSIFICATION	
22a. NAME OF RESPONSIBLE INDIVIDUAL		22b. TELEPHONE (Include Area Code)	22c. OFFICE SYMBOL

PROGRESS REPORT

PERIOD: 15.7.90 TO 21.12.90

During the period starting from July 1990, tasks have largely been concerned with the manufacturing modifications to the test assembly described in the previous report and shown in Figure 1. Operation of the rig has not been possible in this period as the test machine is being modified in our workshops.

The rig stand had previously been prepared which included the connection of the unit to the main plant air and the provision of an upstream combustor. It also included the installation of an ejector at the outlet of the turbine and associated instrumentation. Figure 2 is a diagram of the fully instrumented turbocharger in the test cell.

In addition to the preparatory work described in the first paragraph, work has also been undertaken on the development of a solid seeding device. A seeding device is required to 'seed' the flow with small particles which when passing through the measurement volume of the laser anemometer, scatter light which can be detected by the photodetectors. The particles involved must follow the flow and to achieve this they must be sub-micron. Devices for generating liquid seed particles have been in continual use over recent years but liquid 'seed' has temperature limitations associated with the properties of the liquids being used (a discussion of the problem is made in reference 1). Cold flow tests typically use kerosene or propane diol as liquid but these have severe temperature limitations. Following the advice of Dr A Boutier of ONERA, Cranfield has used silicon oil as a liquid for seeding at temperatures up to 250°C but this appears to be the limit for liquid seeding. Whilst sufficient for some studies in compressors and cold turbine tests, there is a severe limitation for turbine tests and solid seeding techniques have to be adopted. Solid seeding methods have received little attention and are considerably more difficult to use than the liquid variety. When dealing with sub-micron solid particles it is essential to avoid compaction and to avoid moisture since the substances often involved (e.g. titanium dioxide) are highly hygroscopic and quickly forms into aggregate lumps.

The method employed to generate these particles at Cranfield takes a dry air supply through a set of porous plates to a fluidised bed consisting of

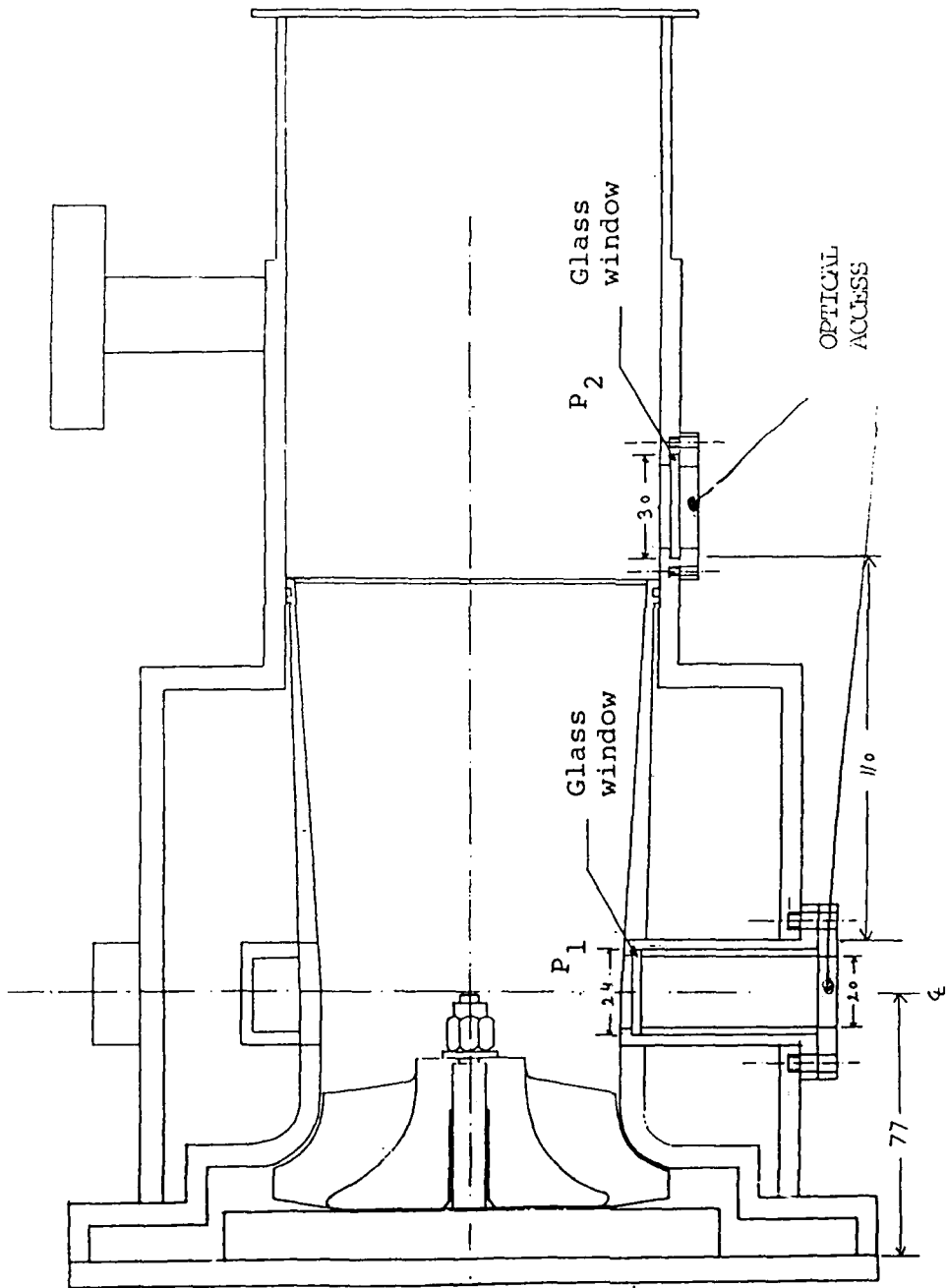

FIG; 1 Optical window positions (P_1 , P_2) downstream the turbine rotor.

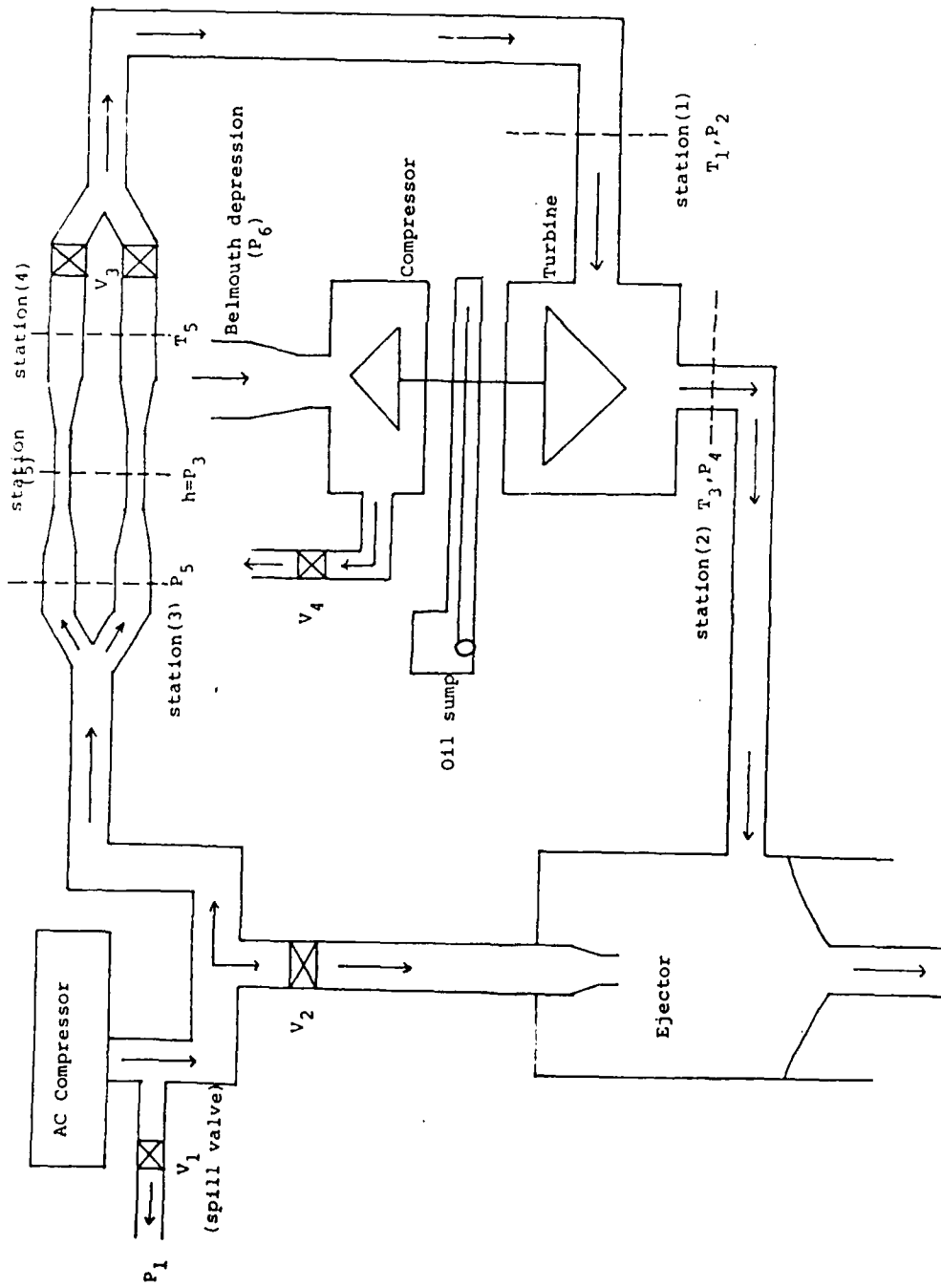
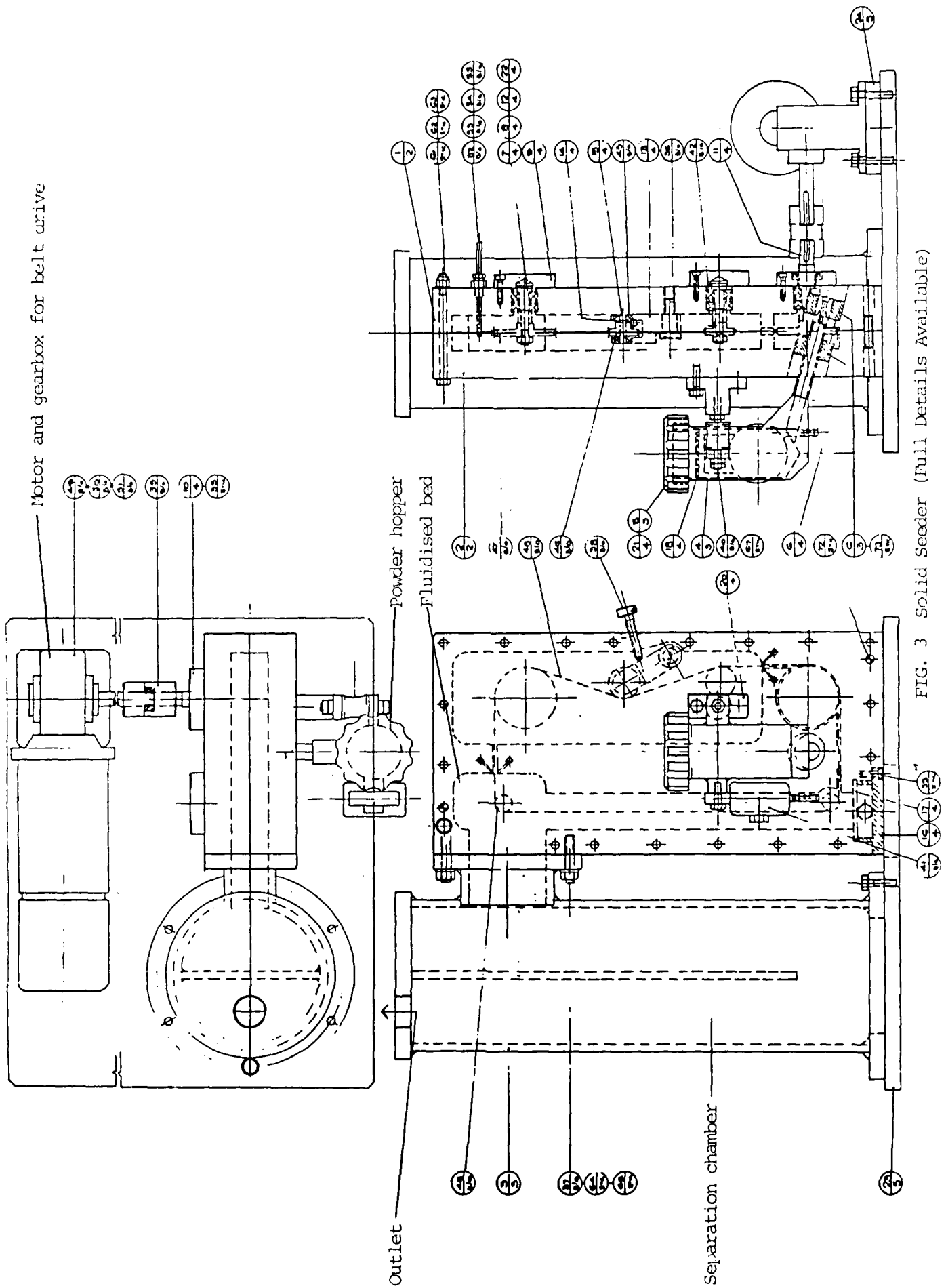

FIG. 2 Schematic diagram for rig installation.



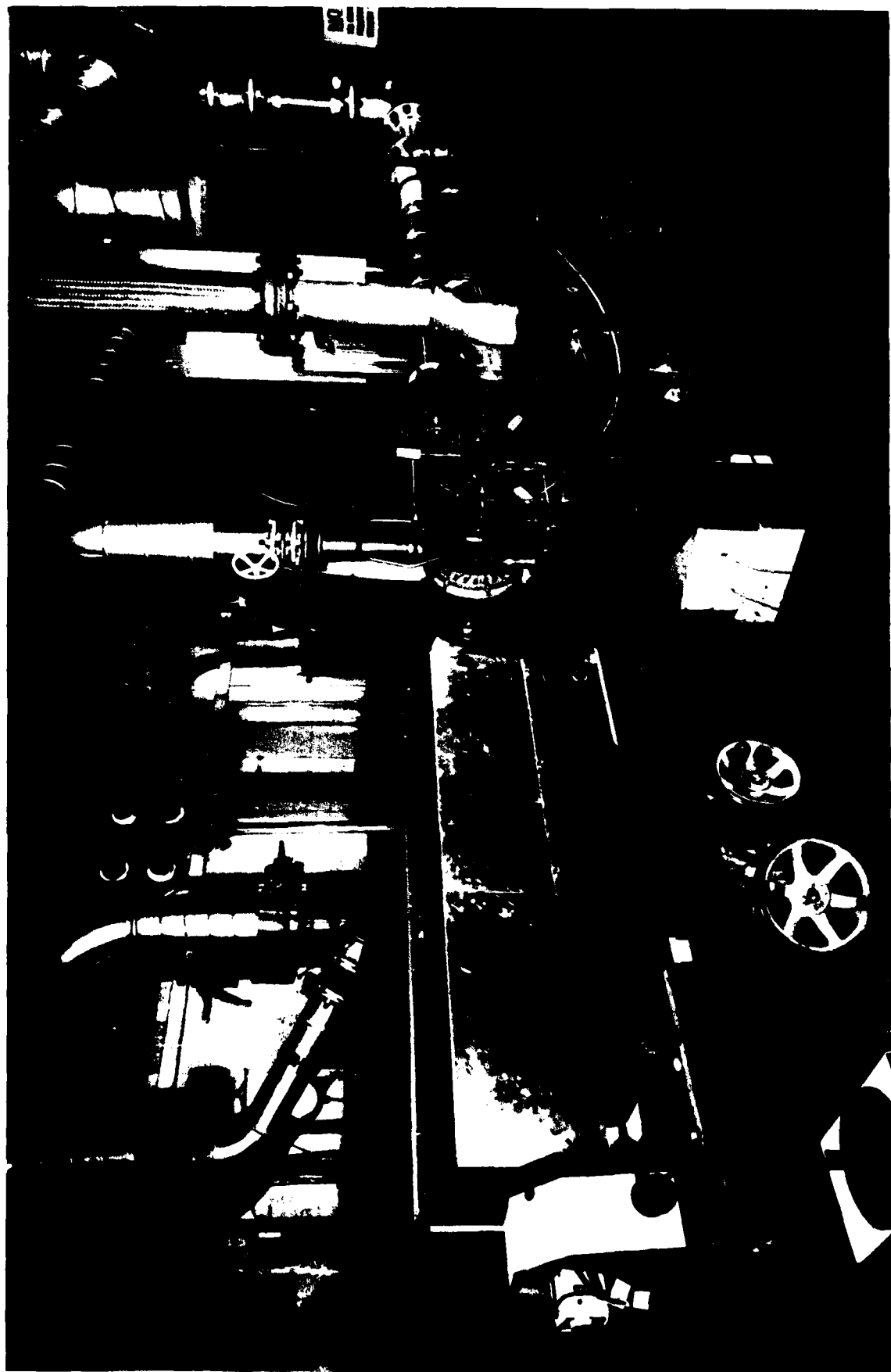

PLATE 1 - LASER ANEMOMETER POSITION ON TURBINE RIG